

APPLICATION FOR CERTIFICATION

On Behalf of

Futaba Corporation

Radio Control

Model No. : TMSS2-2.4G

FCC ID : AZPTMSS2-24G

Brand : Futaba

Prepared for : Futaba Corporation
1080 Yabutsuka Chosei-son Chosei-gun
Chiba, 299-4395 Japan.

Prepared by : Audix Technology Corporation
EMC Department
No. 53-11, Tin-Fu Tsun, Lin-Kou,
Taipei, Taiwan

Tel : (02) 2609-9301, 2609-2133

Fax: (02) 2609-9303

File Number : EM961297
Report Number : EM-F960461
Date of Test : Sep. 20, 2007
Date of Report : Oct. 01, 2007

TABLE OF CONTENTS

Description	Page
TEST REPORT CERTIFICATION	4
1. GENERAL INFORMATION	5
1.1. Description of Device (EUT).....	5
1.2. Tested Supporting System Details.....	6
1.3. Description of Test Facility	7
1.4. Measurement Uncertainty.....	8
2. CONDUCTED EMISSION MEASUREMENT.....	9
3. RADIATED EMISSION MEASUREMENT	10
3.1. Test Equipment.....	10
3.2. Test Setup	10
3.3. Radiated Emission Limits (§15.209)	12
3.4. Operating Condition of EUT	12
3.5. Test Procedure	12
3.6. Test Results.....	13
4. 6dB BANDWIDTH MEASUREMENT	37
4.1. Test Equipment.....	37
4.2. Block Diagram of Test Setup.....	37
4.3. Specification Limits (§15.247(a)(2))	37
4.4. Operating Condition of EUT	37
4.5. Test Procedure	37
4.6. Test Results.....	38
5. MAXIMUM PEAK OUTPUT POWER MEASUREMENT	41
5.1. Test Equipment.....	41
5.2. Block Diagram of Test Setup.....	41
5.3. Specification Limits (§15.247(b)-(3)).....	41
5.4. Operating Condition of EUT	41
5.5. Test Procedure	41
5.6. Test Results.....	42
6. EMISSION LIMITATIONS MEASUREMENT	43
6.1. Test Equipment.....	43
6.2. Block Diagram of Test Setup.....	43
6.3. Specification Limits (§15.247(c)).....	43
6.4. Operating Condition of EUT	43
6.5. Test Procedure	43
6.6. Test Results.....	44
7. BAND EDGES MEASUREMENT.....	47
7.1. Test Equipment.....	47
7.2. Block Diagram of Test Setup.....	47
7.3. Specification Limits (§15.247(c)).....	47
7.4. Operating Condition of EUT	47
7.5. Test Procedure	47
7.6. Test Results.....	47
8. POWER SPECTRAL DENSITY MEASUREMENT	49
8.1. Test Equipment.....	49
8.2. Block Diagram of Test Setup.....	49
8.3. Specification Limits (§15.247(d)).....	49
8.4. Operating Condition of EUT	49
8.5. Test Procedure	49
8.6. Test Results.....	49

9. DEVIATION TO TEST SPECIFICATIONS.....52

10.PHOTOGRAPHS53

10.1. Photos of Radiated Measurement at Semi-Anechoic Chamber 53

10.2. Photo of 6dB Bandwidth Measurement..... 59

10.3. Photo of Maximum Peak Output Measurement..... 59

10.4. Photo of Emission Limitations Measurement..... 60

10.5. Photo of Band Edges Measurement..... 60

10.6. Photo of Power Spectral Density Measurement 61

TEST REPORT CERTIFICATION

Applicant : Futaba Corporation
 Manufacturer : Futaba Corporation
 EUT Description : Radio Control
 FCC ID : AZPTMSS2-24G
 (A) MODEL NO. : TMSS2-2.4G
 (B) SERIAL NO. : N/A
 (C) BRAND : Futaba
 (D) POWER SUPPLY : DC 9.6V
 (E) TEST VOLTAGE : DC 9.6V (DC Power Supply)

Measurement Procedure Used:

FCC RULES AND REGULATIONS PART 15 SUBPART C, MAY 2007
AND ANSI C63.4/2003

(FCC CFR 47 Part 15C, §15.205, §15.207, §15.209 and §15.247)

The device described above was tested by Audix Technology Corporation to determine the maximum emission levels emanating from the device. The maximum emission levels were compared to the FCC Part 15 subpart C limits.

The measurement results are contained in this test report and Audix Technology Corporation is assumed full responsibility for the accuracy and completeness of these measurements. Also, this report shows that the EUT to be technically compliant with the FCC official limits.

This report applies to above tested sample only. This report shall not be reproduced in part without written approval of Audix Technology Corporation.

Date of Test: Sep. 20, 2007

Prepared by: Tina Huang Oct. 04, 2007
(Tina Huang/Assistant)

Test Engineer: Ben Cheng Oct. 05, 2007
(Ben Cheng/Section Manager)

Approved & Authorized Signer: Leon Liu Oct. 5 2007
(Leon Liu/Vice President)

1. GENERAL INFORMATION

1.1. Description of Device (EUT)

Description	:	Radio Control (Transmitter Unit)
Model Number	:	TMSS2-2.4G
Serial Number	:	N/A
Brand	:	Futaba
FCC ID	:	AZPTMSS2-24G
Applicant	:	Futaba Corporation 1080 Yabutsuka Chosei-son Chosei-gun Chiba, 299-4395 Japan.
Manufacturer	:	Futaba Corporation 1080 Yabutsuka Chosei-son Chosei-gun Chiba, 299-4395 Japan.
Radio Technology	:	DSSS Modulation
Frequency Band	:	2405.376MHz ~ 2479.104MHz
Tested Frequency	:	2405.376MHz (Channel 02) 2442.240MHz (Channel 38) 2479.104MHz (Channel 74)
Frequency Channel	:	36 channels
Antenna (Pencil Antenna)	:	Hidaka Denki Work Antenna Gain: 1.64dBi
Receiver	:	Futaba, M/N R617FS FCC by DoC (Report Number: EM-F960462)
Date of Receipt of Sample	:	Sep. 14, 2007
Date of Test	:	Sep. 20, 2007

1.2. Tested Supporting System Details

1.2.1. PC SYSTEM

Model Number : VECTRA XE320
 Serial Number : SG21101966
 FCC ID : By DoC
 BSMI ID : 3912A318
 Brand : HP
 Manufacturer : First International Computer
 Power Cord : Non-Shielded, Detachable, 1.8m

1.2.2. 15" LCD MONITOR

Model Number : D5063M
 Serial Number : CN206A6034
 FCC ID : ARSLM562H
 BSMI ID : R33037
 Manufacturer : Top Victory Electronics (Fujian) Co., Ltd.
 D-Sub Cable : Shielded, Detachable, 1.8m
 AC Adapter : Bonded two ferrite cores
 Delta, M/N ADP-40TB
 BSMI ID 3892D142
 Cord: Shielded, Undetachable, 1.8m
 Bonded a ferrite core
 Power Cord : Non-Shielded, Detachable, 1.8m

1.2.3. KEYBOARD

Model Number : SDM4700P
 Serial Number : B69360HLPPDOR6
 FCC ID : By DoC
 BSMI ID : R33018
 Manufacturer : SAMSUNG (Brand: HP)
 Data Cable : Non-Shielded, Undetachable, 1.8m

1.2.4. MOUSE

Model Number : M-S69
 Serial Number : F6AB70S5BOY1NWZ
 FCC ID : JNZ211443
 BSMI ID : R41126
 Manufacturer : Logitech (Brand: HP)
 Data Cable : Non-Shielded, Undetachable, 1.8m

1.2.5. DC POWER SUPPLY #1 (To EUT)

Model Number : 3303A
 Serial Number : 721773
 Manufacturer : TOP WARD
 DC Power Cable : Non-Shielded, Detachable, 1.2m
 AC Power Cord : Non-Shielded, Detachable, 1.8m

1.2.6. DC POWER SUPPLY #2 (To Conversion Board)

Model Number : 3303D
 Serial Number : 718859
 Manufacturer : TOP WARD
 DC Power Cable : Non-Shielded, Detachable, 0.6m
 AC Power Cord : Non-Shielded, Detachable, 1.8m

1.2.7. CONVERSION BOARD (RS-232 Level Conversion Circuit)

Part Number : 050200006
 Serial Number : N/A
 Manufacturer : FUTABA
 RS-232 Cable : Shielded, Detachable, 1.5m (To PC System)
 Data Cable : Non-Shielded, Detachable, 0.25m (To EUT)

1.3. Description of Test Facility

Name of Firm : **Audix Technology Corporation**
EMC Department
 No. 53-11, Tin-Fu Tsun, Lin-Kou,
 Taipei, Taiwan

Test Location & Facility (AC) : **Semi-Anechoic Chamber**
 No. 53-11, Tin-Fu Tsun, Lin-Kou,
 Taipei, Taiwan.
 May 15, 2006 File on
 Federal Communication Commission
 Registration Number: 90993

NVLAP Lab. Code : 200077-0
 (NVLAP is a NATA accredited body under Mutual Recognition Agreement)

1.4. Measurement Uncertainty

Test Item	Frequency Range	Uncertainty (dB), (V/m)
Radiation Test (Distance: 3m)	30MHz~300MHz	± 2.91dB
	300MHz~1000MHz	± 2.74dB
	Above 1GHz	± 5.02dB

Remark : Uncertainty = $ku_c(y)$

Test Item	Uncertainty
6dB Bandwidth	± 0.05kHz
Emission Limitations	± 0.13dB
Maximum peak output power	± 0.33dBm
Band edges	± 0.13dB
Power spectral density	± 0.13dB

2. CONDUCTED EMISSION MEASUREMENT

【The EUT only employs battery power for operation, no conductive emission limits are required according to FCC Part 15 Section §15.207】

3. RADIATED EMISSION MEASUREMENT

3.1. Test Equipment

The following test equipment was used during the radiated emission measurement:

3.1.1. For Frequency Range 30MHz~1000MHz (at Semi-Anechoic Chamber)

Item	Type	Manufacturer	Model No.	Serial No.	Last Cal.	Next Cal.
1.	Spectrum Analyzer	HP	8593EM	3826A00272	Aug. 26, 07'	Aug. 25, 08'
2.	Test Receiver	R & S	ESCS30	100265	Sep. 04, 07'	Sep. 03, 08'
3.	Pre-Amplifier	HP	8447D	2944A06305	Mar. 03, 07'	Mar. 02, 08'
4.	Biconical Antenna	CHASE	VBA6106A	1264	Apr. 11, 07'	Apr. 10, 08'
5.	Log Periodic Antenna	Schwarzbeck	UHALP91 08-A	0139	Apr. 11, 07'	Apr. 10, 08'

3.1.2. For Frequency Above 1GHz (at Semi-Anechoic Chamber)

Item	Type	Manufacturer	Model No.	Serial No.	Last Cal.	Next Cal.
1.	Spectrum Analyzer	HP	8593EM	3826A00272	Aug. 26, 07'	Aug. 25, 08'
2.	Pre-Amplifier	HP	8449B	3008A01284	Jun. 22, 07'	Jun. 21, 08'
3.	2.4GHz Notch Filter	EWT	EWT-14-0 070	G2	Dec. 08, 06'	Dec. 07, 07'
4.	Horn Antenna	EMCO	3115	9112-3775	May 23, 07'	May 22, 08'
5.	Horn Antenna	EMCO	3116	2653	Oct. 04, 06'	Oct. 03, 07'

3.2. Test Setup

3.2.1. Block Diagram of connection between EUT and simulators

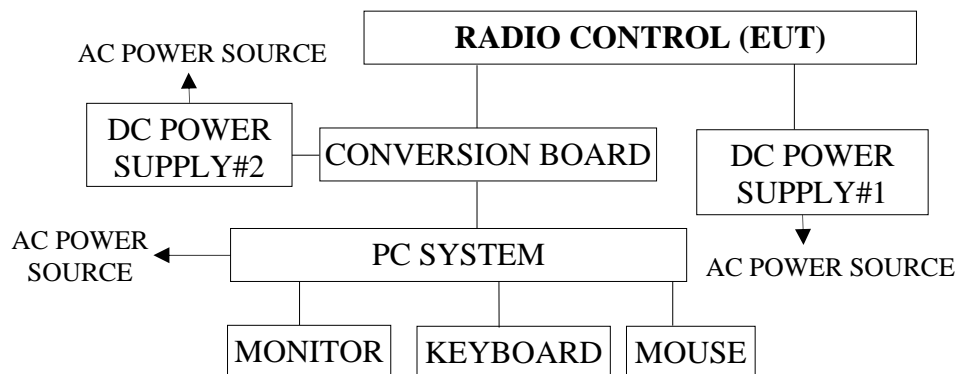

3.2.2. Semi-Anechoic Chamber (3m) Setup Diagram for 30-1000MHz

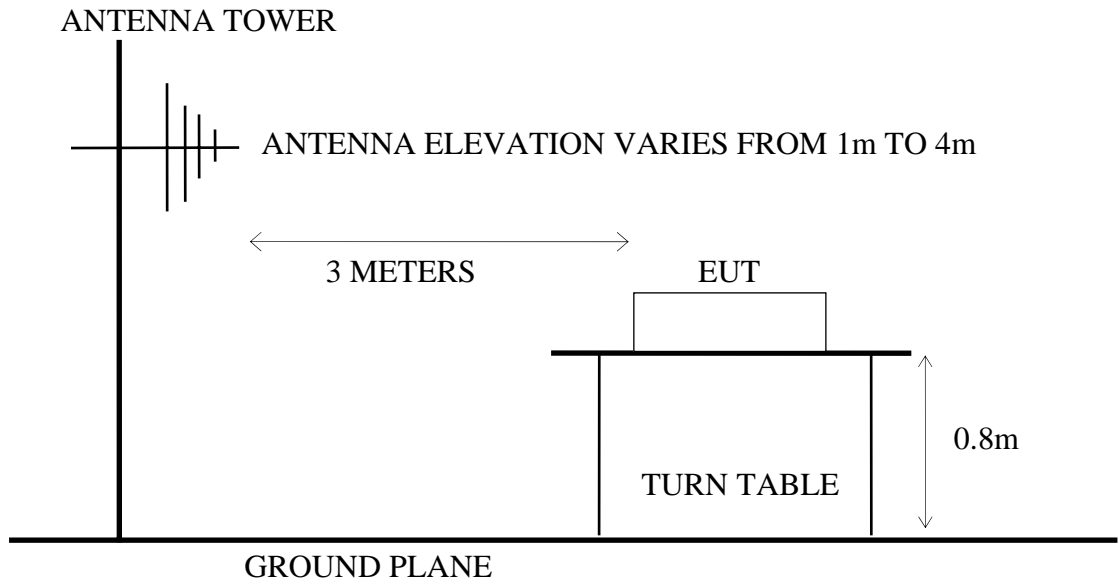

3.2.3. Semi-Anechoic Chamber (3m) Setup Diagram for above 1GHz

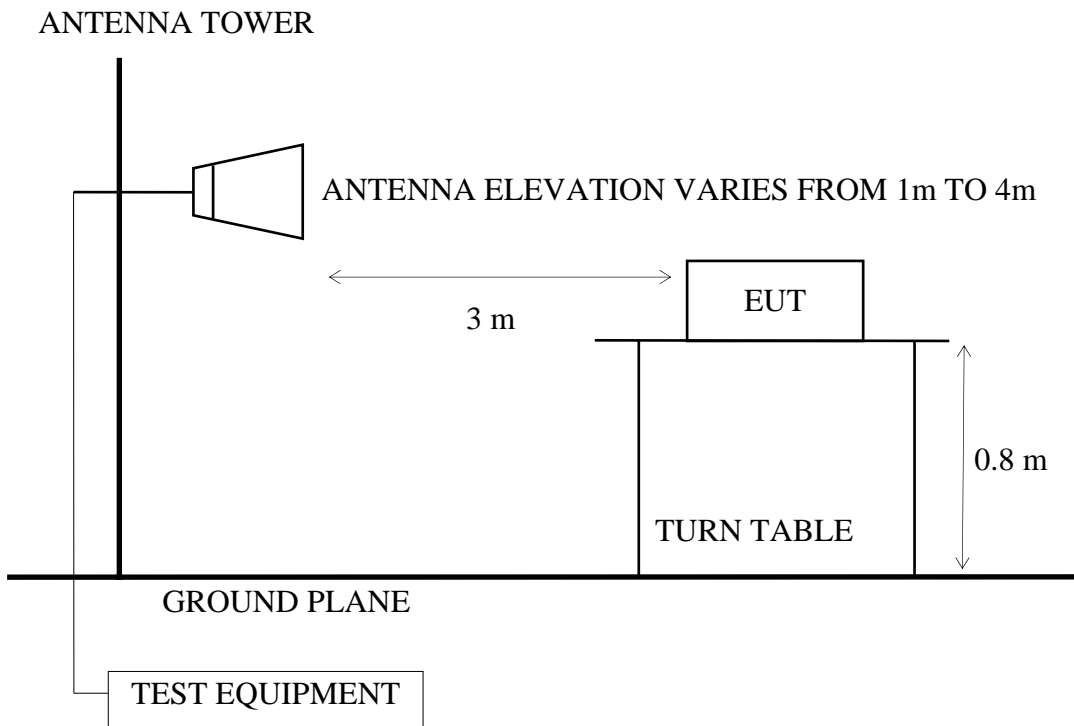

3.3. Radiated Emission Limits (§15.209)

FREQUENCY MHz	DISTANCE Meters	FIELD STRENGTHS LIMITS	
		$\mu\text{V/m}$	$\text{dB}\mu\text{V/m}$
30 ~ 88	3	100	40.0
88 ~ 216	3	150	43.5
216 ~ 960	3	200	46.0
Above 960	3	500	54.0
Above 1000	3	74.0 $\text{dB}\mu\text{V/m}$ (Peak) 54.0 $\text{dB}\mu\text{V/m}$ (Average)	

- Remark :
- (1) Emission level ($\text{dB}\mu\text{V/m}$) = 20 log Emission level ($\mu\text{V/m}$)
 - (2) The tighter limit applies at the edge between two frequency bands.
 - (3) Distance refers to the distance in meters between the measuring instrument antenna and the closed point of any part of the device or system.
 - (4) The limits in this table are based on CFR 47 Part 15.205(a)(b) and Part 15.209 (a).
 - (5) The over 1GHz limit, FCC limit is used based on CFR 47 Part 15.35 (b) and Part 15.205(b) & Part 15.209(e) and Part 15.207(c).

3.4. Operating Condition of EUT

- 3.4.1. Setup the EUT and simulator as shown on 3.2.
- 3.4.2. Turn on the power of all equipment.
- 3.4.3. The EUT was set the PC system using test program “Futaba Term”.
- 3.4.4. The EUT was set to continuously transmit signals at 2405.376MHz (stand), 2442.240MHz (stand) and 2479.104MHz (stand, side and lie) during testing.
- 3.4.5. The EUT was set to continuously receive signals at 2442.240MHz (stand) during testing.

3.5. Test Procedure

The EUT and its simulators were placed on a turn table which was 0.8 meter above the ground. The turn table rotated 360 degrees to determine the position of the maximum emission level. EUT was set 3 meters away from the receiving antenna which was mounted on a antenna tower. The antenna moved up and down between 1 to 4 meters to find out the maximum emission level. Broadband antenna such as calibrated biconical and log-periodical antenna or horn antenna were used as a receiving antenna. Both horizontal and vertical polarization of the antenna were set on measurement. In order to find the maximum emission, all of the interface cables were manipulated according to FCC ANSI C63.4-2003 regulation.

The bandwidth of the R&S Test Receiver ESCS30 was set at 120kHz. (For 30MHz to 1000MHz)

The resolution bandwidth and video bandwidth of test spectrum analyzer is 1MHz for peak detection (PK) at frequency above 1GHz.

The resolution bandwidth of test spectrum analyzer is 1MHz and the video bandwidth is 10Hz for average detection (AV) at frequency above 1GHz.

The frequency range from 30MHz to 25GHz (Up to 10th harmonics from fundamental frequency) was checked.

3.6. Test Results

PASSED.

(All emissions not reported below are too low against the prescribed limits.)

EUT : Radio Control M/N : TMSS2-2.4G

Test Date : Sep. 20, 2007 Temperature : 26 Humidity : 55%

For Frequency Range 30MHz~1000MHz:

The EUT with following test modes were performed during this section testing and all the test results are listed in section 3.6.1.

Mode	Channel	Frequency	Test Mode	Position	Reference Test Data #	
					Horizontal	Vertical
1.	02	2405.376MHz	Transmit	Stand	# 10	# 9
2.	38	2442.240MHz	Transmit	Stand	# 9	# 10
3.	74	2479.104MHz	Transmit	Stand	# 10	# 9
4.				Side	# 9	# 10
5.				Lie	# 10	# 9
6.	38	2442.240MHz	Receive	Stand	# 9	# 10

* Above all final readings were measured with Quasi-Peak detector.

For Frequency above 1GHz:

The EUT with following test modes were performed during this section testing and all the test results are listed in section 3.6.2.

Mode	Channel	Frequency	Test Mode	Position
1.	02	2405.376MHz	Transmit	Stand
2.	38	2442.240MHz	Transmit	Stand
3.	74	2479.104MHz	Transmit	Stand
4.				Side
5.				Lie
6.	38	2442.240MHz	Receive	Stand

* Above all final readings were measured with Peak detector and Average detector.

For Restricted Bands:

The EUT was tested in restricted bands and all the test results are listed in section 3.6.3. (The restricted bands defined in part 15.205(a))

Mode	Channel	Frequency	Test Mode
1.	02	2405.376MHz	Transmit
2.	74	2479.104MHz	Transmit

3.6.1. Frequency Range 30-1000MHz



AUDIX TECHNOLOGY Corp. EMC Laboratory
 No.53-11, Tin-fu Tsun, Lin-kou Hsiang, Taipei
 County, Taiwan R.O.C. Post Code:24443
 Tel:+886-2-26092133 Fax:+886-2-26099303
 Email:ttemc@ttemc.

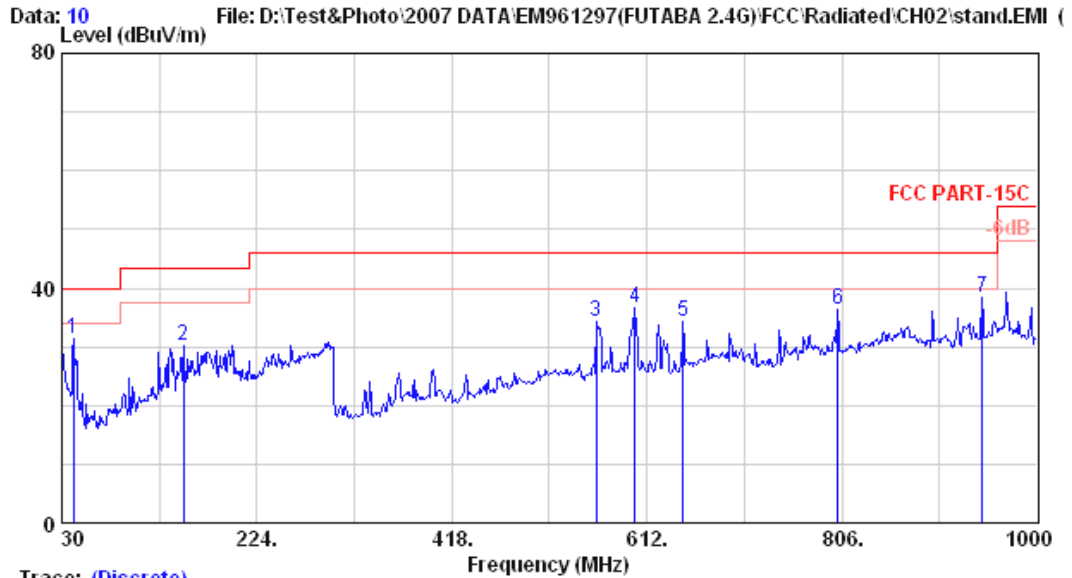

Trace: (Discrete)

Site no.	: A/C Chamber	Data no.	: 10
Dis. / Ant.	: 3m VBA6106A/UHALP9108A	Ant. pol.	: HORIZONTAL
Limit	: FCC PART-15C		
Env. / Ins.	: ESCS30 26°C/55%	Engineer	: Alvin_Yang
EUT	: Radio Control M/N:TMSS2-2.4G		
Power Rating	: DC 9.6V		
Test Mode	: Stand(CH02)		

	Ant.	Cable	Emission		Limits	Margin	Remark
Freq. (MHz)	Factor (dB/m)	Loss (dB)	Reading (dBµV)	Level (dBµV/m)	(dBµV/m)	(dB)	
1	41.640	20.14	1.30	9.80	31.24	40.00	8.76
2	151.250	20.65	2.60	6.98	30.23	43.50	13.27
3	561.560	20.16	6.70	7.42	34.28	46.00	11.72
4	600.360	21.31	6.30	9.08	36.69	46.00	9.31
5	647.890	21.34	6.30	6.74	34.38	46.00	11.62
6	802.120	24.17	6.90	5.20	36.26	46.00	9.74
7	945.680	25.68	7.50	5.25	38.42	46.00	7.58

Remarks: 1. Emission Level= Antenna Factor + Cable Loss + Reading.
 2. The emission levels that are 20dB below the official limit are not reported.



AUDIX TECHNOLOGY Corp. EMC Laboratory
 No.53-11, Tin-fu Tsun, Lin-kou Hsiang, Taipei
 County, Taiwan R.O.C. Post Code:24443
 Tel:+886-2-26092133 Fax:+886-2-26099303
 Email:ttemc@ttemc.

Data: 9 File: D:\Test&Photo\2007 DATA\EM961297(FUTABA 2.4G)\FCC\Radiated\CH02\stand.EMI (

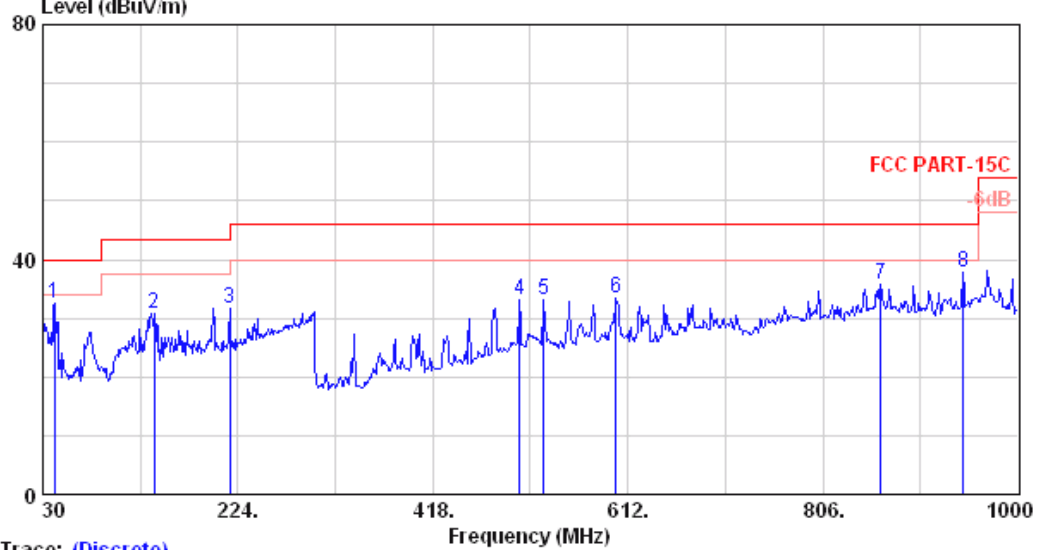

Trace: (Discrete)
 Site no. : A/C Chamber Data no. : 9
 Dis. / Ant. : 3m VBA6106A/UHALP9108A Ant. pol. : VERTICAL
 Limit : FCC PART-15C
 Env. / Ins. : ESCS30 26°C/55% Engineer : Alvin_Yang
 EUT : Radio Control M/N: TMSS2-2.4G
 Power Rating : DC 9.6V
 Test Mode : Stand(CH02)

	Ant.	Cable	Emission		Limits	Margin	Remark
Freq. (MHz)	Factor (dB/m)	Loss (dB)	Reading (dBμV)	Level (dBμV/m)	(dBμV/m)	(dB)	
1	41.640	20.14	1.30	10.99	32.43	40.00	7.57
2	140.580	20.22	2.50	8.15	30.87	43.50	12.63
3	216.240	21.86	3.20	6.65	31.72	46.00	14.28
4	504.330	19.02	6.62	7.38	33.03	46.00	12.97
5	528.580	19.69	6.90	6.54	33.13	46.00	12.87
6	600.360	21.31	6.30	5.82	33.44	46.00	12.56
7	863.230	26.09	7.20	2.56	35.85	46.00	10.15
8	945.680	25.68	7.50	4.56	37.74	46.00	8.26

Remarks: 1. Emission Level= Antenna Factor + Cable Loss + Reading.
 2. The emission levels that are 20dB below the official limit are not reported.



AUDIX TECHNOLOGY Corp. EMC Laboratory
 No.53-11, Tin-fu Tsun, Lin-kou Hsiang, Taipei
 County, Taiwan R.O.C. Post Code:24443
 Tel:+886-2-26092133 Fax:+886-2-26099303
 Email:ttemc@ttemc.

Data: 9 File: D:\Test&Photo\2007 DATA\EM961297(FUTABA 2.4G)\FCC\Radiated\CH38\stand.EMI (

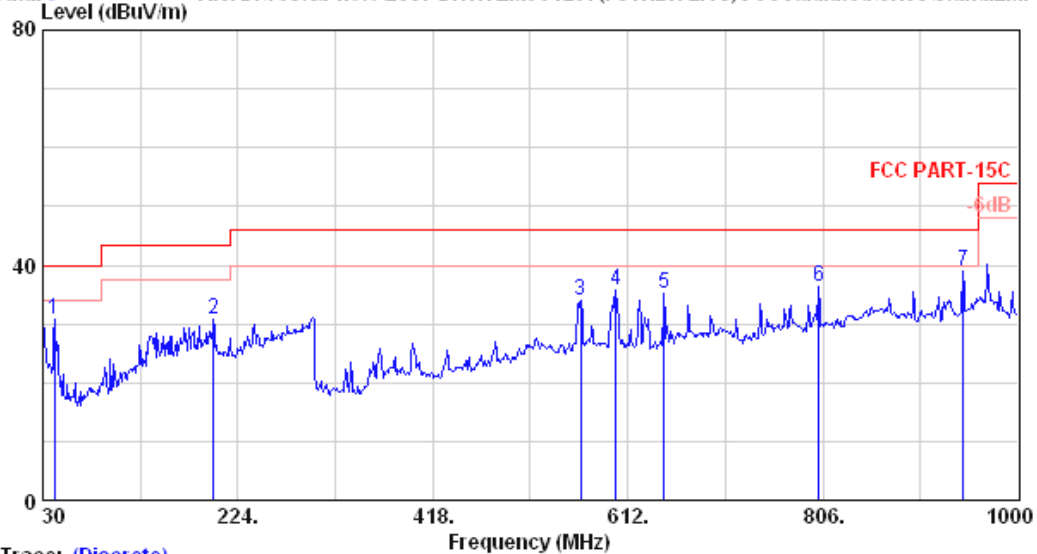

Trace: (Discrete)
 Site no. : A/C Chamber Data no. : 9
 Dis. / Ant. : 3m VBA6106A/UHALP9108A Ant. pol. : HORIZONTAL
 Limit : FCC PART-15C
 Env. / Ins. : ESCS30 26°C/55% Engineer : Alvin_Yang
 EUT : Radio Control M/N:TMSS2-2.4G
 Power Rating : DC 9.6V
 Test Mode : Stand(CH38)

	Ant. Factor	Cable Loss	Reading	Emission Level	Limits	Margin	Remark
Freq. (MHz)	(dB/m)	(dB)	(dBμV)	(dBμV/m)	(dBμV/m)	(dB)	
1	20.14	1.30	9.29	30.73	40.00	9.27	
2	22.09	3.00	5.81	30.89	43.50	12.61	
3	20.49	6.60	6.86	33.95	46.00	12.05	
4	21.31	6.30	8.25	35.86	46.00	10.14	
5	21.34	6.30	7.39	35.03	46.00	10.97	
6	24.17	6.90	5.35	36.41	46.00	9.59	
7	25.68	7.50	5.75	38.92	46.00	7.08	

Remarks: 1. Emission Level= Antenna Factor + Cable Loss + Reading.
 2. The emission levels that are 20dB below the official limit are not reported.



AUDIX TECHNOLOGY Corp. EMC Laboratory
 No.53-11, Tin-fu Tsun, Lin-kou Hsiang, Taipei
 County, Taiwan R.O.C. Post Code:24443
 Tel:+886-2-26092133 Fax:+886-2-26099303
 Email:ttemc@ttemc.

Data: 10 File: D:\Test&Photo\2007 DATA\EM961297(FUTABA 2.4G)\FCC\Radiated\CH38\stand.EMI (

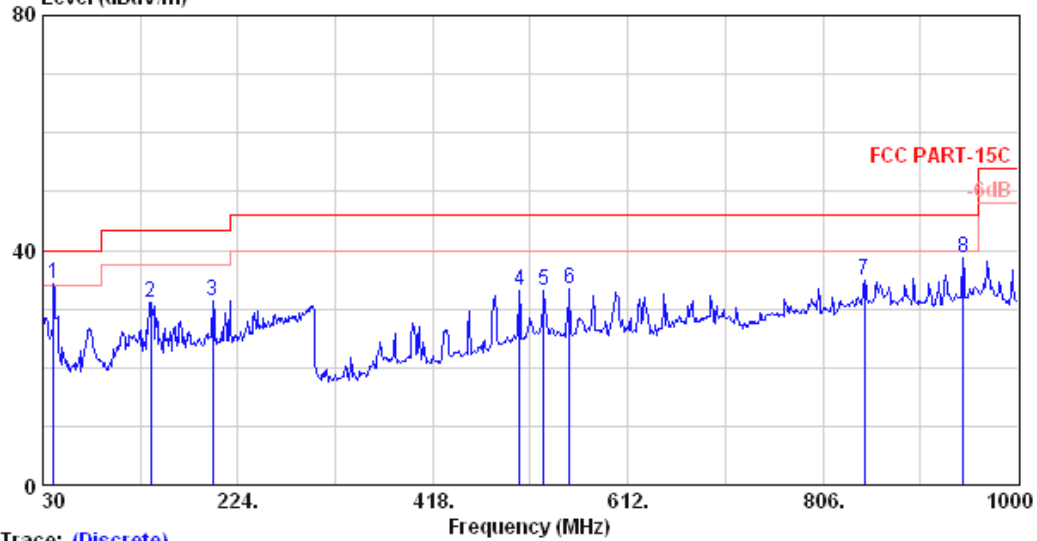

Trace: (Discrete)
 Site no. : A/C Chamber Data no. : 10
 Dis. / Ant. : 3m VBA6106A/UHALP9108A Ant. pol. : VERTICAL
 Limit : FCC PART-15C
 Env. / Ins. : ESCS30 26°C/55% Engineer : Alvin_Yang
 EUT : Radio Control M/N:TMSS2-2.4G
 Power Rating : DC 9.6V
 Test Mode : Stand(CH38)

	Ant. Factor	Cable Loss	Reading	Emission Level	Limits	Margin	Remark
Freq. (MHz)	(dB/m)	(dB)	(dBμV)	(dBμV/m)	(dBμV/m)	(dB)	
1	20.36	1.30	12.53	34.19	40.00	5.81	
2	20.01	2.43	8.68	31.12	43.50	12.38	
3	22.07	3.00	6.32	31.39	43.50	12.11	
4	19.02	6.62	7.56	33.20	46.00	12.80	
5	19.69	6.90	6.58	33.17	46.00	12.83	
6	19.40	6.80	7.26	33.46	46.00	12.54	
7	25.43	7.10	2.38	34.90	46.00	11.10	
8	25.68	7.50	5.58	38.75	46.00	7.25	

Remarks: 1. Emission Level= Antenna Factor + Cable Loss + Reading.
 2. The emission levels that are 20dB below the official limit are not reported.



AUDIX TECHNOLOGY Corp. EMC Laboratory
 No.53-11, Tin-fu Tsun, Lin-kou Hsiang, Taipei
 County, Taiwan R.O.C. Post Code:24443
 Tel:+886-2-26092133 Fax:+886-2-26099303
 Email:ttemc@ttemc.

Data: 10 File: D:\Test&Photo\2007 DATA\EM961297(FUTABA 2.4G)\FCC\Radiated\CH74\stand.EMI (

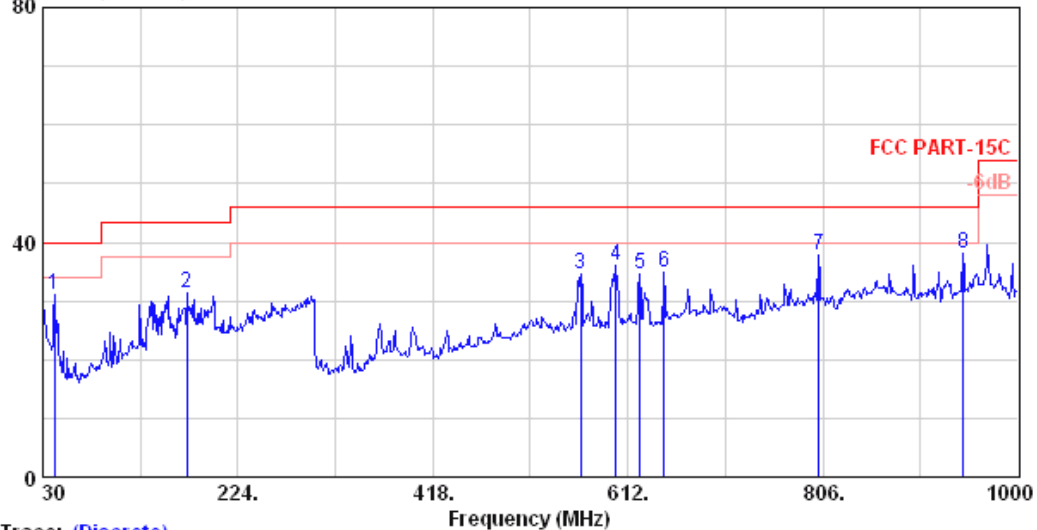

Trace: (Discrete)
 Site no. : A/C Chamber Data no. : 10
 Dis. / Ant. : 3m VBA6106A/UHALP9108A Ant. pol. : HORIZONTAL
 Limit : FCC PART-15C
 Env. / Ins. : ESCS30 26°C/55% Engineer : Alvin_Yang
 EUT : Radio Control M/N:TMSS2-2.4G
 Power Rating : DC 9.6V
 Test Mode : Stand(CH74)

	Freq. (MHz)	Ant. Factor (dB/m)	Cable Loss (dB)	Reading (dBµV)	Emission Level (dBµV/m)	Limits (dBµV/m)	Margin (dB)	Remark
1	41.640	20.14	1.30	9.73	31.17	40.00	8.83	
2	173.560	21.08	2.80	7.48	31.36	43.50	12.14	
3	565.440	20.49	6.60	7.38	34.47	46.00	11.53	
4	600.360	21.31	6.30	8.42	36.03	46.00	9.97	
5	623.640	21.32	6.20	7.02	34.54	46.00	11.46	
6	647.890	21.34	6.30	7.15	34.79	46.00	11.21	
7	802.120	24.17	6.90	6.85	37.92	46.00	8.08	
8	945.680	25.68	7.50	4.90	38.07	46.00	7.93	

Remarks: 1. Emission Level= Antenna Factor + Cable Loss + Reading.
 2. The emission levels that are 20dB below the official limit are not reported.



AUDIX TECHNOLOGY Corp. EMC Laboratory
 No.53-11, Tin-fu Tsun, Lin-kou Hsiang, Taipei
 County, Taiwan R.O.C. Post Code:24443
 Tel:+886-2-26092133 Fax:+886-2-26099303
 Email:ttemc@ttemc.

Data: 9 File: D:\Test&Photo\2007 DATA\EM961297(FUTABA 2.4G)\FCC\Radiated\CH74\stand.EMI (

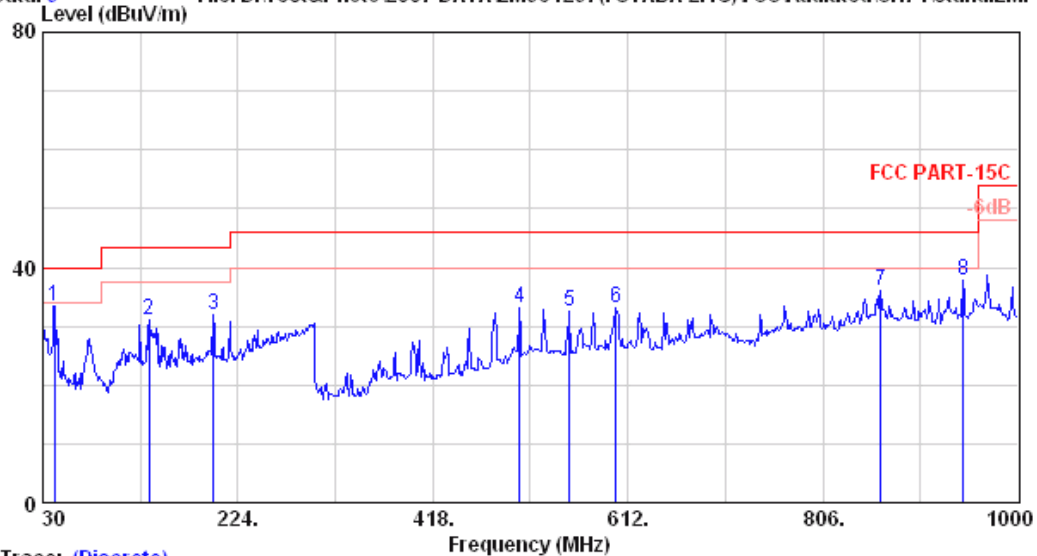

Trace: (Discrete)
 Site no. : A/C Chamber Data no. : 9
 Dis. / Ant. : 3m VBA6106A/UHALP9108A Ant. pol. : VERTICAL
 Limit : FCC PART-15C
 Env. / Ins. : ESCS30 26°C/55% Engineer : Alvin_Yang
 EUT : Radio Control M/N: TMSS2-2.4G
 Power Rating : DC 9.6V
 Test Mode : Stand(CH74)

	Ant. Factor	Cable Loss	Reading	Emission Level	Limits	Margin	Remark
Freq. (MHz)	(dB/m)	(dB)	(dBμV)	(dBμV/m)	(dBμV/m)	(dB)	
1	20.14	1.30	12.09	33.53	40.00	6.47	
2	19.95	2.40	8.84	31.19	43.50	12.31	
3	22.09	3.00	6.78	31.87	43.50	11.63	
4	19.02	6.62	7.57	33.21	46.00	12.79	
5	19.40	6.80	6.44	32.64	46.00	13.36	
6	21.31	6.30	5.39	33.00	46.00	13.00	
7	26.09	7.20	2.79	36.08	46.00	9.92	
8	25.68	7.50	4.68	37.85	46.00	8.15	

Remarks: 1. Emission Level= Antenna Factor + Cable Loss + Reading.
 2. The emission levels that are 20dB below the official limit are not reported.



AUDIX TECHNOLOGY Corp. EMC Laboratory
 No.53-11, Tin-fu Tsun, Lin-kou Hsiang, Taipei
 County, Taiwan R.O.C. Post Code:24443
 Tel:+886-2-26092133 Fax:+886-2-26099303
 Email:ttemc@ttemc.

Data: 9 File: D:\Test&Photo\2007 DATA\EM961297(FUTABA 2.4G)\FCC\Radiated\CH74\side.EMI (1)
 Level (dBuV/m)

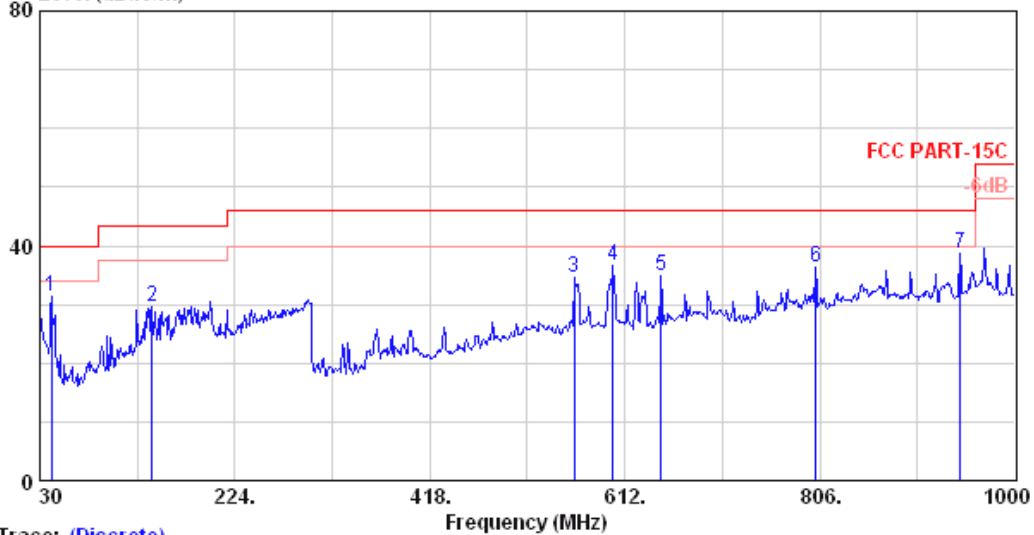

Trace: (Discrete)
 Site no. : A/C Chamber Data no. : 9
 Dis. / Ant. : 3m VBA6106A/UHALP9108A Ant. pol. : HORIZONTAL
 Limit : FCC PART-15C
 Env. / Ins. : ESCS30 26+C/55% Engineer : Alvin_Yang
 EUT : Radio Control M/N:TMSS2-2.4G
 Power Rating : DC 9.6V
 Test Mode : Side(CH74)

	Ant.	Cable	Emission		Limits	Margin	Remark
Freq. (MHz)	Factor (dB/m)	Loss (dB)	Reading (dBμV)	Level (dBμV/m)	(dBμV/m)	(dB)	
1	41.640	20.14	1.30	10.06	31.50	40.00	8.50
2	141.550	20.25	2.50	6.81	29.56	43.50	13.94
3	561.560	20.16	6.70	7.78	34.65	46.00	11.35
4	600.360	21.31	6.30	8.92	36.54	46.00	9.46
5	647.890	21.34	6.30	7.09	34.73	46.00	11.27
6	802.120	24.17	6.90	5.13	36.20	46.00	9.80
7	945.680	25.68	7.50	5.48	38.65	46.00	7.35

Remarks: 1. Emission Level= Antenna Factor + Cable Loss + Reading.
 2. The emission levels that are 20dB below the official limit are not reported.



AUDIX TECHNOLOGY Corp. EMC Laboratory
 No.53-11, Tin-fu Tsun, Lin-kou Hsiang, Taipei
 County, Taiwan R.O.C. Post Code:24443
 Tel:+886-2-26092133 Fax:+886-2-26099303
 Email:ttemc@ttemc.

Data: 10 File: D:\Test&Photo\2007 DATA\EM961297(FUTABA 2.4G)\FCC\Radiated\CH74\side.EMI (1)

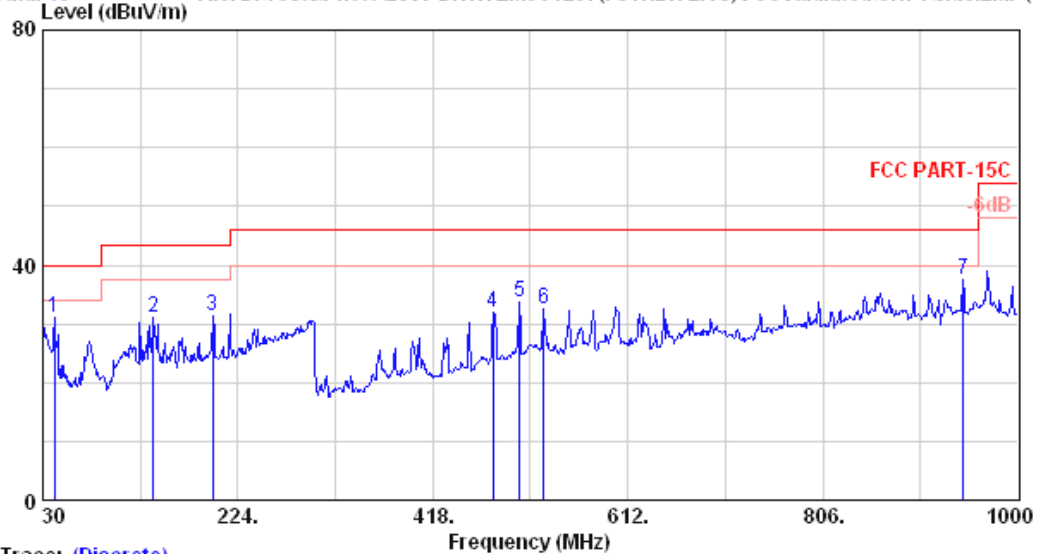

Trace: (Discrete)
 Site no. : A/C Chamber Data no. : 10
 Dis. / Ant. : 3m VBA6106A/UHALP9108A Ant. pol. : VERTICAL
 Limit : FCC PART-15C
 Env. / Ins. : ESCS30 26°C/55% Engineer : Alvin_Yang
 EUT : Radio Control M/N:TMSS2-2.4G
 Power Rating : DC 9.6V
 Test Mode : Side(CH74)

	Ant. Cable		Emission		Limits	Margin	Remark
Freq. (MHz)	Factor (dB/m)	Loss (dB)	Reading (dBuV)	Level (dBuV/m)			
1	41.640	20.14	1.30	9.58	31.02	40.00	8.98
2	139.610	20.15	2.50	8.51	31.15	43.50	12.35
3	198.780	22.07	3.00	6.33	31.40	43.50	12.10
4	478.140	18.61	6.00	7.37	31.98	46.00	14.02
5	504.330	19.02	6.62	7.92	33.56	46.00	12.44
6	528.580	19.69	6.90	6.01	32.59	46.00	13.41
7	945.680	25.68	7.50	4.32	37.49	46.00	8.51

Remarks: 1. Emission Level= Antenna Factor + Cable Loss + Reading.
 2. The emission levels that are 20dB below the official limit are not reported.



AUDIX TECHNOLOGY Corp. EMC Laboratory
 No.53-11, Tin-fu Tsun, Lin-kou Hsiang, Taipei
 County, Taiwan R.O.C. Post Code:24443
 Tel:+886-2-26092133 Fax:+886-2-26099303
 Email:ttemc@ttemc.

Data: 10 File: D:\Test&Photo\2007 DATA\EM961297(FUTABA 2.4G)\FCC\Radiated\CH74\lie.EMI (10)

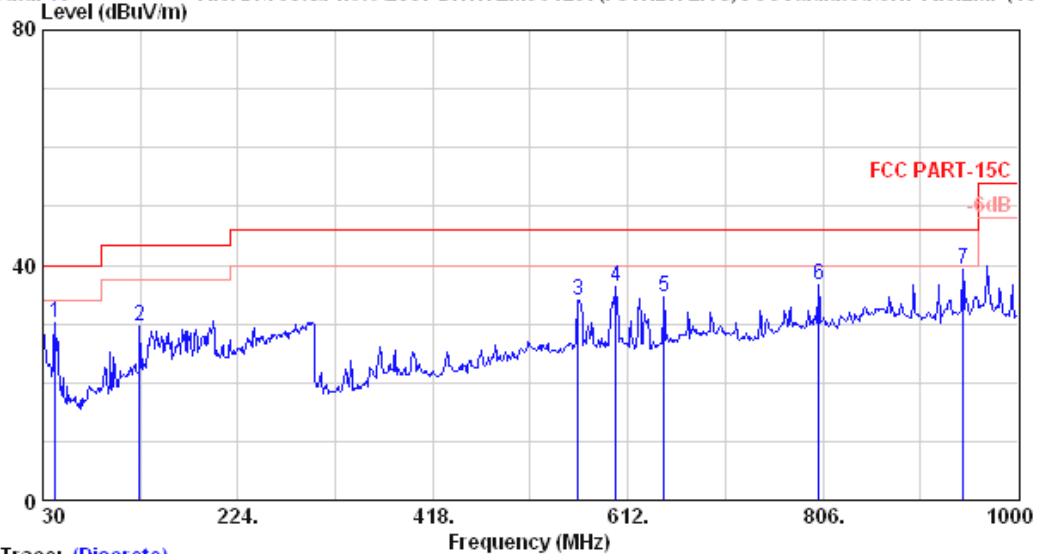

Trace: (Discrete)
 Site no. : A/C Chamber Data no. : 10
 Dis. / Ant. : 3m VBA6106A/UHALP9108A Ant. pol. : HORIZONTAL
 Limit : FCC PART-15C
 Env. / Ins. : ESCS30 26°C/55% Engineer : Alvin_Yang
 EUT : Radio Control M/N:TMSS2-2.4G
 Power Rating : DC 9.6V
 Test Mode : Lie(CH74)

	Ant. Cable		Emission		Limits	Margin	Remark
Freq. (MHz)	Factor (dB/m)	Loss (dB)	Reading (dBμV)	Level (dBμV/m)			
1	42.610	19.86	1.30	9.08	30.24	40.00	9.76
2	126.030	19.49	2.38	7.80	29.66	43.50	13.84
3	562.530	20.23	6.67	7.24	34.13	46.00	11.87
4	600.360	21.31	6.30	8.82	36.43	46.00	9.57
5	647.890	21.34	6.30	6.90	34.54	46.00	11.46
6	802.120	24.17	6.90	5.42	36.49	46.00	9.51
7	945.680	25.68	7.50	6.01	39.18	46.00	6.82

Remarks: 1. Emission Level= Antenna Factor + Cable Loss + Reading.
 2. The emission levels that are 20dB below the official limit are not reported.



AUDIX TECHNOLOGY Corp. EMC Laboratory
 No.53-11, Tin-fu Tsun, Lin-kou Hsiang, Taipei
 County, Taiwan R.O.C. Post Code:24443
 Tel:+886-2-26092133 Fax:+886-2-26099303
 Email:ttemc@ttemc.

Data: 9 File: D:\Test&Photo\2007 DATA\EM961297(FUTABA 2.4G)\FCC\Radiated\CH74\lie.EMI (10)

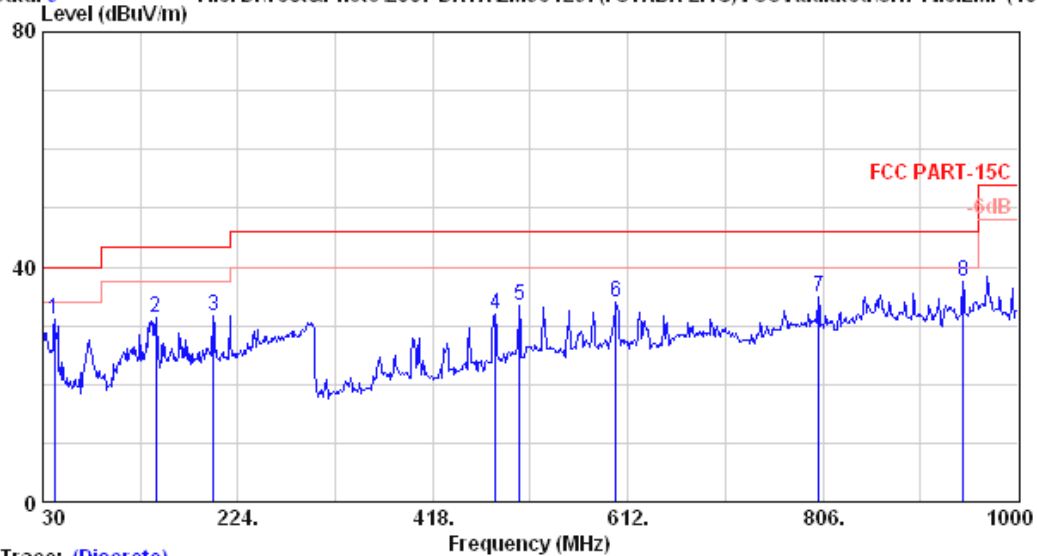

Trace: (Discrete)
 Site no. : A/C Chamber Data no. : 9
 Dis. / Ant. : 3m VBA6106A/UHALP9108A Ant. pol. : VERTICAL
 Limit : FCC PART-15C
 Env. / Ins. : ESCS30 26°C/55% Engineer : Alvin_Yang
 EUT : Radio Control M/N:TMSS2-2.4G
 Power Rating : DC 9.6V
 Test Mode : Lie(CH74)

	Freq. (MHz)	Ant. Factor (dB/m)	Cable Loss (dB)	Reading (dBµV)	Emission Level (dBµV/m)	Limits (dBµV/m)	Margin (dB)	Remark
1	41.640	20.14	1.30	9.73	31.17	40.00	8.83	
2	142.520	20.26	2.50	8.45	31.22	43.50	12.28	
3	199.750	22.09	3.00	6.55	31.64	43.50	11.86	
4	480.080	18.68	6.05	7.28	32.01	46.00	13.99	
5	504.330	19.02	6.62	7.83	33.47	46.00	12.53	
6	600.360	21.31	6.30	6.44	34.05	46.00	11.95	
7	802.120	24.17	6.90	3.91	34.97	46.00	11.03	
8	945.680	25.68	7.50	4.35	37.52	46.00	8.48	

Remarks: 1. Emission Level= Antenna Factor + Cable Loss + Reading.
 2. The emission levels that are 20dB below the official limit are not reported.



AUDIX TECHNOLOGY Corp. EMC Laboratory
 No.53-11, Tin-fu Tsun, Lin-kou Hsiang, Taipei
 County, Taiwan R.O.C. Post Code:24443
 Tel:+886-2-26092133 Fax:+886-2-26099303
 Email:ttemc@ttemc.

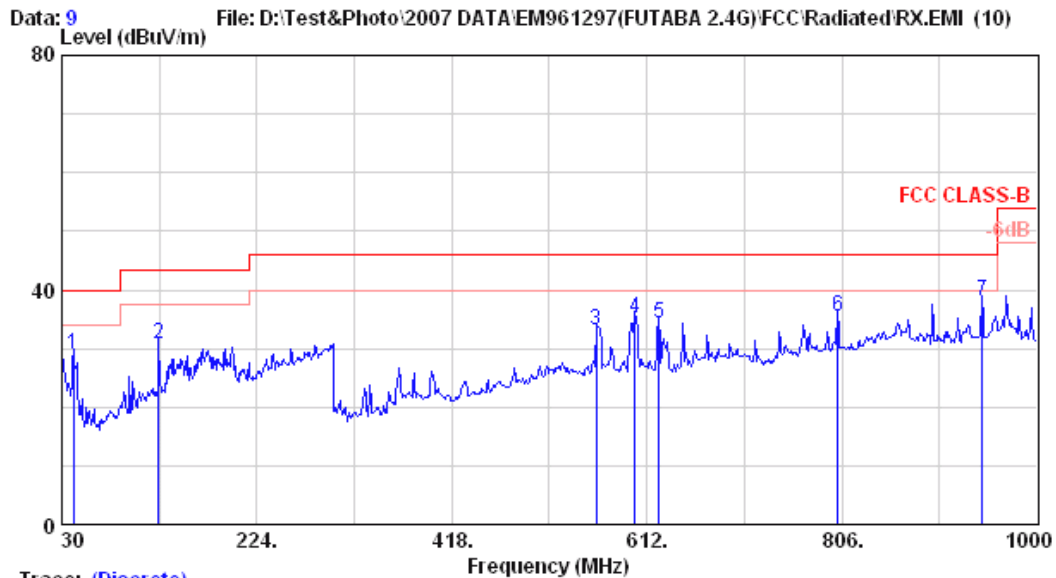

Trace: (Discrete)

Site no. : A/C Chamber Data no. : 9
 Dis. / Ant. : 3m VBA6106A/UHALP9108A Ant. pol. : HORIZONTAL
 Limit : FCC CLASS-B
 Env. / Ins. : ESCS30 26°C/55% Engineer : Alvin_Yang
 EUT : Radio Control M/N:TMSS2-2.4G
 Power Rating : DC 9.6V
 Test Mode : RX(CH38)

	Freq. (MHz)	Ant. Factor (dB/m)	Cable Loss (dB)	Reading (dBµV)	Emission Level (dBµV/m)	Limits (dBµV/m)	Margin (dB)	Remark
1	41.640	20.14	1.30	7.52	28.96	40.00	11.04	
2	126.030	19.49	2.38	8.86	30.73	43.50	12.77	
3	561.560	20.16	6.70	6.16	33.02	46.00	12.98	
4	600.360	21.31	6.30	7.62	35.23	46.00	10.77	
5	623.640	21.32	6.20	6.88	34.40	46.00	11.60	
6	802.120	24.17	6.90	4.41	35.48	46.00	10.52	
7	945.680	25.68	7.50	4.82	37.99	46.00	8.01	

Remarks: 1. Emission Level= Antenna Factor + Cable Loss + Reading.
 2. The emission levels that are 20dB below the official limit are not reported.



AUDIX TECHNOLOGY Corp. EMC Laboratory
 No.53-11, Tin-fu Tsun, Lin-kou Hsiang, Taipei
 County, Taiwan R.O.C. Post Code:24443
 Tel:+886-2-26092133 Fax:+886-2-26099303
 Email:ttemc@ttemc.

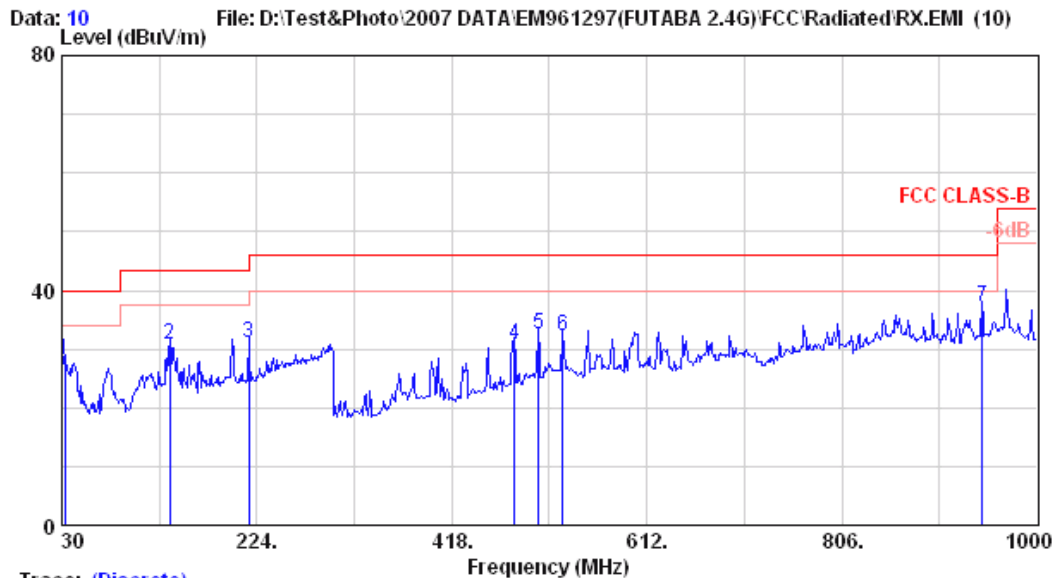

Trace: (Discrete)

Site no. : A/C Chamber Data no. : 10
 Dis. / Ant. : 3m VBA6106A/UHALP9108A Ant. pol. : VERTICAL
 Limit : FCC CLASS-B
 Env. / Ins. : ESCS30 26°C/55% Engineer : Alvin_Yang
 EUT : Radio Control M/N:TMSS2-2.4G
 Power Rating : DC 9.6V
 Test Mode : RX(CH38)

	Ant. Factor	Cable Loss	Reading	Emission Level	Limits	Margin	Remark
Freq. (MHz)	(dB/m)	(dB)	(dBμV)	(dBμV/m)	(dBμV/m)	(dB)	
1	23.42	1.10	3.51	28.03	40.00	11.97	
2	20.01	2.43	8.34	30.78	43.50	12.72	
3	21.86	3.20	5.98	31.04	46.00	14.96	
4	18.68	6.05	6.18	30.91	46.00	15.09	
5	19.02	6.62	6.78	32.43	46.00	13.57	
6	19.69	6.90	5.76	32.35	46.00	13.65	
7	25.68	7.50	3.92	37.10	46.00	8.90	

Remarks: 1. Emission Level= Antenna Factor + Cable Loss + Reading.
 2. The emission levels that are 20dB below the official limit are not reported.

3.6.2. Above 1GHz Frequency Range Measurement Results

Date of Test : Sep. 20, 2007 Temperature : 26

EUT : Radio Control Humidity : 55%

Test Mode : Transmit, Channel: 02 (Frequency: 2405.376MHz), Position: Stand

	Emission Frequency MHz	Antenna Factor dB/m	Cable Loss dB	Meter Reading Horizontal dBµV	Emission Level Horizontal dBµV/m	Limits dBµV/m	Margin dB
Peak	1006.720	25.20	4.19	11.70	41.09	74.00	32.91
	1325.920	25.34	4.91	10.98	41.23	74.00	32.77
	1465.360	25.39	5.33	11.67	42.39	74.00	31.61
	1846.720	27.13	6.65	7.86	41.64	74.00	32.36
Average	1006.720	25.20	4.19	3.70	33.09	54.00	20.91
	1325.920	25.34	4.91	2.98	33.23	54.00	20.77
	1465.360	25.39	5.33	3.67	34.39	54.00	19.61
	1846.720	27.13	6.65	-0.14	33.64	54.00	20.36

	Emission Frequency MHz	Antenna Factor dB/m	Cable Loss dB	Meter Reading Vertical dBµV	Emission Level Vertical dBµV/m	Limits dBµV/m	Margin dB
Peak	1006.720	25.20	4.19	13.04	42.43	74.00	31.57
	1191.520	25.29	4.56	12.04	41.89	74.00	32.11
	1603.120	25.95	6.18	9.01	41.14	74.00	32.86
	2565.760	29.09	6.58	11.81	47.48	74.00	26.52
Average	1006.720	25.20	4.19	5.04	34.43	54.00	19.57
	1191.520	25.29	4.56	4.04	33.89	54.00	20.11
	1603.120	25.95	6.18	1.01	33.14	54.00	20.86
	2565.760	29.09	6.58	3.81	39.48	54.00	14.52

Remark : 1. Emission Level = Antenna Factor + Cable Loss + Meter Reading.
 2. Measurement was up to 25GHz, but the emissions level were too low against the official limit and not report.

Date of Test : Sep. 20, 2007 Temperature : 26
 EUT : Radio Control Humidity : 55%
 Test Mode : Transmit, Channel: 38 (Frequency: 2442.240MHz), Position: Stand

	Emission Frequency MHz	Antenna Factor dB/m	Cable Loss dB	Meter Reading Horizontal dBμV	Emission Level Horizontal dBμV/m	Limits dBμV/m	Margin dB
Peak	1006.720	25.20	4.19	10.80	40.19	74.00	33.81
	1460.320	25.39	5.31	10.61	41.31	74.00	32.69
	1729.120	26.58	7.04	9.46	44.71	74.00	29.29
	2375.920	28.57	6.32	9.82	44.71	74.00	29.29
Average	1006.720	25.20	4.19	2.80	32.19	54.00	21.81
	1460.320	25.39	5.31	2.61	33.31	54.00	20.69
	1729.120	26.58	7.04	1.46	36.71	54.00	11.34
	2375.920	28.57	6.32	1.82	36.71	54.00	17.29

	Emission Frequency MHz	Antenna Factor dB/m	Cable Loss dB	Meter Reading Vertical dBμV	Emission Level Vertical dBμV/m	Limits dBμV/m	Margin dB
Peak	1006.720	25.20	4.19	14.22	43.61	74.00	30.39
	1196.560	25.29	4.58	11.29	41.16	74.00	32.84
	1729.120	26.58	7.04	8.92	44.09	74.00	29.91
	2305.360	28.44	6.23	9.42	44.09	74.00	29.91
Average	1006.720	25.20	4.19	6.22	35.61	54.00	18.39
	1196.560	25.29	4.58	3.29	33.16	54.00	20.84
	1729.120	26.58	7.04	0.92	36.09	54.00	11.34
	2305.360	28.44	6.23	1.42	36.09	54.00	17.91

Remark : 1. Emission Level = Antenna Factor + Cable Loss + Meter Reading.
 2. Measurement was up to 25GHz, but the emissions level were too low against the official limit and not report.

Date of Test : Sep. 20, 2007 Temperature : 26

EUT : Radio Control Humidity : 55%

Test Mode : Transmit, Channel: 74 (Frequency: 2479.104MHz), Position: Stand

	Emission Frequency MHz	Antenna Factor dB/m	Cable Loss dB	Meter Reading Horizontal dBµV	Emission Level Horizontal dBµV/m	Limits dBµV/m	Margin dB
Peak	1456.960	25.39	5.31	10.39	41.09	74.00	32.91
	1653.520	26.22	6.52	11.93	44.67	74.00	29.33
Average	1456.960	25.39	5.31	2.39	33.09	54.00	20.91
	1653.520	26.22	6.52	2.93	35.67	54.00	18.33

	Emission Frequency MHz	Antenna Factor dB/m	Cable Loss dB	Meter Reading Vertical dBµV	Emission Level Vertical dBµV/m	Limits dBµV/m	Margin dB
Peak	1006.720	25.20	4.19	13.97	43.36	74.00	30.64
	1196.560	25.29	4.58	12.12	41.99	74.00	32.01
	1465.360	25.39	5.33	10.56	41.28	74.00	32.72
	1653.520	26.22	6.52	11.87	44.61	74.00	29.39
	1729.120	26.58	7.04	9.92	43.54	74.00	30.46
Average	1006.720	25.20	4.19	5.97	35.36	54.00	18.64
	1196.560	25.29	4.58	4.12	33.99	54.00	20.01
	1465.360	25.39	5.33	2.56	33.28	54.00	20.72
	1653.520	26.22	6.52	3.87	36.61	54.00	17.39
	1729.120	26.58	7.04	1.92	35.54	54.00	18.46

Remark : 1. Emission Level = Antenna Factor + Cable Loss + Meter Reading.
 2. Measurement was up to 25GHz, but the emissions level were too low against the official limit and not report.

Date of Test : Sep. 20, 2007 Temperature : 26

EUT : Radio Control Humidity : 55%

Test Mode : Transmit, Channel: 74 (Frequency: 2479.104MHz), Position: Side

	Emission Frequency MHz	Antenna Factor dB/m	Cable Loss dB	Meter Reading Horizontal dBµV	Emission Level Horizontal dBµV/m	Limits dBµV/m	Margin dB
Peak	1006.720	25.20	4.19	12.04	41.43	74.00	32.57
	1460.320	25.39	5.31	9.38	40.08	74.00	33.92
	1650.160	26.19	6.49	11.60	44.28	74.00	29.72
	1729.120	26.58	7.04	8.48	42.10	74.00	31.90
Average	1006.720	25.20	4.19	4.04	33.43	54.00	20.57
	1460.320	25.39	5.31	1.38	32.08	54.00	21.92
	1650.160	26.19	6.49	3.60	36.28	54.00	17.72
	1729.120	26.58	7.04	0.48	34.10	54.00	19.90

	Emission Frequency MHz	Antenna Factor dB/m	Cable Loss dB	Meter Reading Vertical dBµV	Emission Level Vertical dBµV/m	Limits dBµV/m	Margin dB
Peak	1006.720	25.20	4.19	14.11	43.50	74.00	30.50
	1460.320	25.39	5.31	9.72	40.42	74.00	33.58
	1650.160	26.19	6.49	10.80	43.48	74.00	30.52
Average	1006.720	25.20	4.19	6.11	35.50	54.00	18.50
	1460.320	25.39	5.31	1.72	32.42	54.00	21.58
	1650.160	26.19	6.49	2.80	35.48	54.00	18.52

Remark : 1. Emission Level = Antenna Factor + Cable Loss + Meter Reading.
 2. Measurement was up to 25GHz, but the emissions level were too low against the official limit and not report.

Date of Test : Sep. 20, 2007 Temperature : 26

EUT : Radio Control Humidity : 55%

Test Mode : Transmit, Channel: 74 (Frequency: 2479.104MHz), Position: Lie

	Emission Frequency MHz	Antenna Factor dB/m	Cable Loss dB	Meter Reading Horizontal dBµV	Emission Level Horizontal dBµV/m	Limits dBµV/m	Margin dB
Peak	1006.720	25.20	4.19	11.89	41.28	74.00	32.72
	1460.320	25.39	5.31	10.62	41.32	74.00	32.68
	1653.520	26.22	6.52	10.11	42.85	74.00	31.15
	1725.760	26.58	7.00	9.07	42.65	74.00	31.35
Average	1006.720	25.20	4.19	3.89	33.28	54.00	20.72
	1460.320	25.39	5.31	2.62	33.32	54.00	20.68
	1653.520	26.22	6.52	2.11	34.85	54.00	19.15
	1725.760	26.58	7.00	1.07	34.65	54.00	19.35

	Emission Frequency MHz	Antenna Factor dB/m	Cable Loss dB	Meter Reading Vertical dBµV	Emission Level Vertical dBµV/m	Limits dBµV/m	Margin dB
Peak	1006.720	25.20	4.19	14.36	43.75	74.00	30.25
	1191.520	25.29	4.56	13.61	43.46	74.00	30.54
	1653.520	26.22	6.52	11.31	44.05	74.00	29.95
Average	1006.720	25.20	4.19	6.36	35.75	54.00	18.25
	1191.520	25.29	4.56	5.61	35.46	54.00	18.54
	1653.520	26.22	6.52	3.31	36.05	54.00	17.95

Remark : 1. Emission Level = Antenna Factor + Cable Loss + Meter Reading.
 2. Measurement was up to 25GHz, but the emissions level were too low against the official limit and not report.

Date of Test : Sep. 20, 2007 Temperature : 26
 EUT : Radio Control Humidity : 55%
 Test Mode : Receive, Channel: 38 (Frequency: 2442.240MHz), Position: Stand

	Emission Frequency MHz	Antenna Factor dB/m	Cable Loss dB	Meter Reading Horizontal dBμV	Emission Level Horizontal dBμV/m	Limits dBμV/m	Margin dB
Peak	1006.720	25.20	4.19	11.96	41.35	74.00	32.65
	1129.360	25.26	4.42	9.51	39.19	74.00	34.81
	1460.320	25.39	5.31	14.27	44.97	74.00	29.03
	1720.720	26.55	6.96	9.15	42.66	74.00	31.34
Average	1006.720	25.20	4.19	3.96	33.35	54.00	20.65
	1129.360	25.26	4.45	1.51	31.22	54.00	22.78
	1460.320	25.39	5.31	6.27	36.97	54.00	17.03
	1720.720	26.55	6.96	1.15	34.66	54.00	19.34

	Emission Frequency MHz	Antenna Factor dB/m	Cable Loss dB	Meter Reading Vertical dBμV	Emission Level Vertical dBμV/m	Limits dBμV/m	Margin dB
Peak	1006.720	25.20	4.19	14.23	43.62	74.00	30.38
	1196.560	25.29	4.58	11.84	41.71	74.00	32.29
	1465.360	25.39	5.33	9.75	40.47	74.00	33.53
	1720.720	26.55	6.96	9.46	42.97	74.00	31.03
Average	1006.720	25.20	4.19	6.23	35.62	54.00	18.38
	1196.560	25.29	4.58	3.84	33.71	54.00	20.29
	1465.360	25.39	5.33	1.75	32.47	54.00	21.53
	1720.720	26.55	5.96	1.46	33.97	54.00	20.03

Remark : 1. Emission Level = Antenna Factor + Cable Loss + Meter Reading.
 2. Measurement was up to 25GHz, but the emissions level were too low against the official limit and not report.

3.6.3. Restricted Bands Measurement Results

Date of Test : Sep. 20, 2007 Temperature : 26

EUT : Radio Control Humidity : 55%

Test Mode : Transmit, Channel: 02, Frequency: 2405.376MHz

	Emission Frequency MHz	Antenna Factor dB/m	Cable Loss dB	Meter Reading Horizontal dBμV	Emission Level Horizontal dBμV/m	Limits dBμV/m	Margin dB
Peak *	2386.340	28.59	6.33	10.87	45.79	74.00	28.21
Average *	2386.890	28.59	6.33	-0.38	34.54	54.00	19.46

- Remark : 1. Emission Level = Antenna Factor + Cable Loss + Meter Reading.
 2. Low frequency section (spurious in the restricted band 2310-2390MHz).
 3. '*' The field strength of emission appearing within Part 15.205(a) shall not exceed the limits shown in section 15.209.



AUDIX TECHNOLOGY Corp. EMC Laboratory
 No.53-11, Tin-Fu Tsun, Lin-kou Hsiang, Taipei County, Taiwan R.O.C. Post Code:24443
 Tel:+886-2-26092133 Fax:+886-2-26099303
 Email:ttenc@ttenc.com



AUDIX TECHNOLOGY Corp. EMC Laboratory
 No.53-11, Tin-Fu Tsun, Lin-kou Hsiang, Taipei County, Taiwan R.O.C. Post Code:24443
 Tel:+886-2-26092133 Fax:+886-2-26099303
 Email:ttenc@ttenc.com

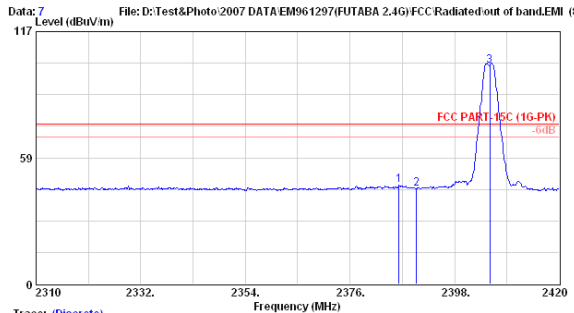

Site no. : A/C Chamber Data no. : 7
 Dis. / Ant. : 3m 3115 Ant. pol. : HORIZONTAL
 Limit : FCC PART-15C (1G-PK)
 Env. / Ins. : 8593EM 26°C/55% Engineer : Alvin_Yang
 EUT : Radio Control M/N:TMSS2-2.4G
 Power Rating : DC 9.6V
 Test Mode : Stand(CH02)

Freq. (MHz)	Ant. Factor (dB/m)	Cable Loss (dB)	Reading (dBμV)	Emission Level (dBμV/m)	Limits (dBμV/m)	Margin (dB)	Remark
1 2386.340	28.59	6.33	10.87	45.80	74.00	28.20	Peak
2 2390.000	28.59	6.34	9.23	44.16	74.00	29.84	Peak
3 2405.376	28.63	6.36	66.15	101.14	74.00	-27.14	Peak

Remarks: 1. Emission Level= Antenna Factor + Cable Loss + Reading.
 2. The emission levels that are 20dB below the official limit are not reported.

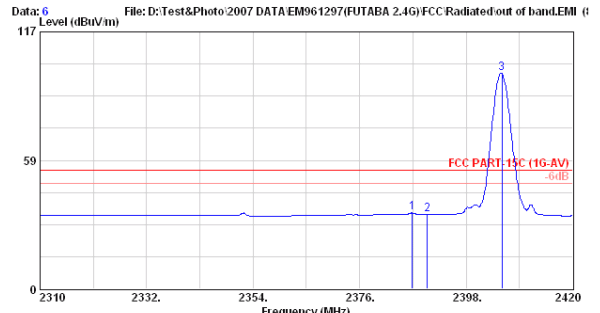

Site no. : A/C Chamber Data no. : 6
 Dis. / Ant. : 3m 3115 Ant. pol. : HORIZONTAL
 Limit : FCC PART-15C (1G-AV)
 Env. / Ins. : 8593EM 26°C/55% Engineer : Alvin_Yang
 EUT : Radio Control M/N:TMSS2-2.4G
 Power Rating : DC 9.6V
 Test Mode : Stand(CH02)

Freq. (MHz)	Ant. Factor (dB/m)	Cable Loss (dB)	Reading (dBμV)	Emission Level (dBμV/m)	Limits (dBμV/m)	Margin (dB)	Remark
1 2386.890	28.59	6.33	-0.38	34.54	54.00	19.46	Average
2 2390.000	28.59	6.34	-1.07	33.87	54.00	20.13	Average
3 2405.376	28.63	6.36	63.32	98.31	54.00	-44.31	Average

Remarks: 1. Emission Level= Antenna Factor + Cable Loss + Reading.
 2. The emission levels that are 20dB below the official limit are not reported.

Date of Test : Sep. 20, 2007 Temperature : 26

EUT : Radio Control Humidity : 55%

Test Mode : Transmit, Channel: 02, Frequency: 2405.376MHz

	Emission Frequency MHz	Antenna Factor dB/m	Cable Loss dB	Meter Reading Vertical dBμV	Emission Level Vertical dBμV/m	Limits dBμV/m	Margin dB
Peak *	2386.670	28.59	6.33	15.48	50.40	74.00	23.60
Average *	2386.890	28.59	6.33	7.94	42.86	54.00	11.14

- Remark : 1. Emission Level = Antenna Factor + Cable Loss + Meter Reading.
 2. Low frequency section (spurious in the restricted band 2310-2390MHz).
 3. ‘*’ The field strength of emission appearing within Part 15.205(a) shall not exceed the limits shown in section 15.209.



AUDIX TECHNOLOGY Corp. EMC Laboratory
 No.53-11, Tin-fu Tsun, Lin-kou Hsiang, Taipei
 County, Taiwan R.O.C. Post Code:24443
 Tel:+886-2-26092133 Fax:+886-2-26099303
 Email:ttmc@ttmc.com



AUDIX TECHNOLOGY Corp. EMC Laboratory
 No.53-11, Tin-fu Tsun, Lin-kou Hsiang, Taipei
 County, Taiwan R.O.C. Post Code:24443
 Tel:+886-2-26092133 Fax:+886-2-26099303
 Email:ttmc@ttmc.com

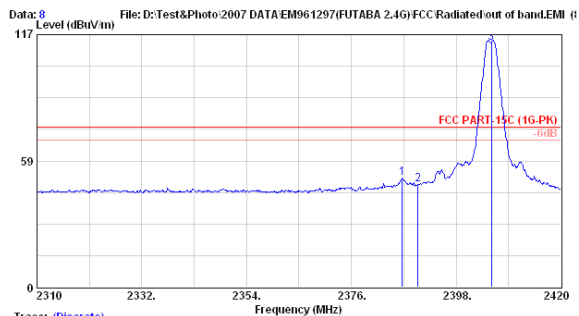

Site no. : A/C Chamber Data no. : 8
 Dis. / Ant. : 3m 3115 Ant. pol. : VERTICAL
 Limit : FCC PART-15C (1G-PR)
 Env. / Ins. : 8593EM 26°C/55% Engineer : Alvin_Yang
 EUT : Radio Control M/N:TMSS2-2.4G
 Power Rating : DC 9.6V
 Test Mode : Stand (CH02)

Freq. (MHz)	Ant. Factor (dB/m)	Cable Loss (dB)	Reading (dBμV)	Emission Level (dBμV/m)	Limits (dBμV/m)	Margin (dB)	Remark
1 2386.670	28.59	6.33	15.48	50.41	74.00	23.59	Peak
2 2390.000	28.59	6.34	12.83	47.76	74.00	26.24	Peak
3 2405.376	28.63	6.36	78.12	113.11	74.00	-39.11	Peak

Remarks: 1. Emission Level= Antenna Factor + Cable Loss + Reading.
 2. The emission levels that are 20dB below the official limit are not reported.

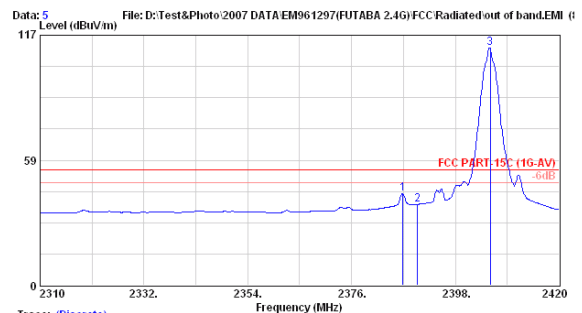

Site no. : A/C Chamber Data no. : 5
 Dis. / Ant. : 3m 3115 Ant. pol. : VERTICAL
 Limit : FCC PART-15C (1G-AV)
 Env. / Ins. : 8593EM 26°C/55% Engineer : Alvin_Yang
 EUT : Radio Control M/N:TMSS2-2.4G
 Power Rating : DC 9.6V
 Test Mode : Stand (CH02)

Freq. (MHz)	Ant. Factor (dB/m)	Cable Loss (dB)	Reading (dBμV)	Emission Level (dBμV/m)	Limits (dBμV/m)	Margin (dB)	Remark
1 2386.890	28.59	6.33	7.94	42.86	54.00	11.14	Average
2 2390.000	28.59	6.34	2.92	37.85	54.00	16.15	Average
3 2405.376	28.63	6.36	75.92	110.91	54.00	-56.91	Average

Remarks: 1. Emission Level= Antenna Factor + Cable Loss + Reading.
 2. The emission levels that are 20dB below the official limit are not reported.

Date of Test : Sep. 20, 2007 Temperature : 26

EUT : Radio Control Humidity : 55%

Test Mode : Transmit, Channel: 74, Frequency: 2479.104MHz

	Emission Frequency MHz	Antenna Factor dB/m	Cable Loss dB	Meter Reading Horizontal dBμV	Emission Level Horizontal dBμV/m	Limits dBμV/m	Margin dB
Peak *	2485.200	28.77	6.45	13.41	48.63	74.00	25.37
Average *	2485.200	28.77	6.45	3.19	38.41	54.00	15.59

- Remark : 1. Emission Level = Antenna Factor + Cable Loss + Meter Reading.
 2. High frequency section (spurious in the restricted band 2483.5-2500MHz).
 3. '*' The field strength of emission appearing within Part 15.205(a) shall not exceed the limits shown in section 15.209.



AUDIX TECHNOLOGY Corp. EMC Laboratory
 No.53-11, Tin-fu Tsun, Lin-kou Hsiang, Taipei
 County, Taiwan R.O.C. Post Code 24443
 Tel:+886-2-26092133 Fax:+886-2-26099303
 Email:tema@itemc.com



AUDIX TECHNOLOGY Corp. EMC Laboratory
 No.53-11, Tin-fu Tsun, Lin-kou Hsiang, Taipei
 County, Taiwan R.O.C. Post Code 24443
 Tel:+886-2-26092133 Fax:+886-2-26099303
 Email:tema@itemc.com

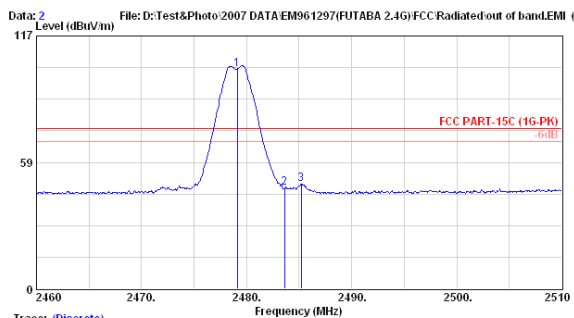

Trace: (Discrete)
 Site no. : A/C Chamber Data no. : 2
 Dis. / Ant. : 3m 3115 Ant. pol. : HORIZONTAL
 Limit : FCC PART-15C (1G-PK)
 Env. / Ins. : 8593EM 26°C/55% Engineer : Alvin_Yang
 EUT : Radio Control M/N:TM882-2.4G
 Power Rating : DC 9.6V
 Test Mode : Stand(CH74)

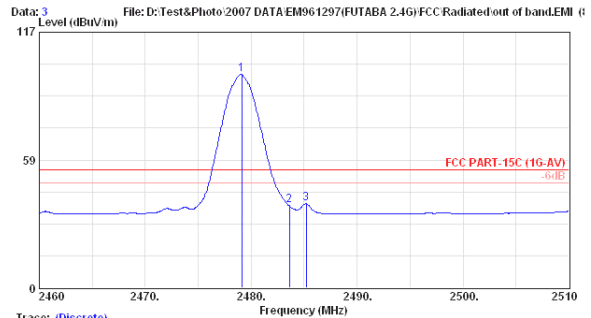

Trace: (Discrete)
 Site no. : A/C Chamber Data no. : 3
 Dis. / Ant. : 3m 3115 Ant. pol. : HORIZONTAL
 Limit : FCC PART-15C (1G-AV)
 Env. / Ins. : 8593EM 26°C/55% Engineer : Alvin_Yang
 EUT : Radio Control M/N:TM882-2.4G
 Power Rating : DC 9.6V
 Test Mode : Stand(CH74)

Freq. (MHz)	Ant. Factor (dB/m)	Cable Loss (dB)	Reading (dBμV)	Emission Level (dBμV/m)	Limits (dBμV/m)	Margin (dB)	Remark
1 2479.104	28.76	6.44	66.57	101.77	74.00	-27.77	Peak
2 2483.600	28.77	6.45	11.29	46.52	74.00	27.48	Peak
3 2485.200	28.77	6.45	13.41	48.63	74.00	25.37	Peak

Remarks: 1. Emission Level= Antenna Factor + Cable Loss + Reading.
 2. The emission levels that are 20dB below the official limit are not reported.

Freq. (MHz)	Ant. Factor (dB/m)	Cable Loss (dB)	Reading (dBμV)	Emission Level (dBμV/m)	Limits (dBμV/m)	Margin (dB)	Remark
1 2479.104	28.76	6.44	62.34	97.54	54.00	-43.54	Average
2 2483.600	28.77	6.45	2.28	37.51	54.00	16.49	Average
3 2485.200	28.77	6.45	3.19	38.41	54.00	15.59	Average

Remarks: 1. Emission Level= Antenna Factor + Cable Loss + Reading.
 2. The emission levels that are 20dB below the official limit are not reported.

Date of Test : Sep. 20, 2007 Temperature : 26

EUT : Radio Control Humidity : 55%

Test Mode : Transmit, Channel: 74, Frequency: 2479.104MHz

	Emission Frequency MHz	Antenna Factor dB/m	Cable Loss dB	Meter Reading Vertical dBμV	Emission Level Vertical dBμV/m	Limits dBμV/m	Margin dB
Peak *	2485.100	28.77	6.45	23.48	58.70	74.00	15.30
Average *	2485.220	28.77	6.45	16.22	51.44	54.00	2.56

- Remark : 1. Emission Level = Antenna Factor + Cable Loss + Meter Reading.
 2. High frequency section (spurious in the restricted band 2483.5-2500MHz).
 3. ‘*’ The field strength of emission appearing within Part 15.205(a) shall not exceed the limits shown in section 15.209.



AUDIX TECHNOLOGY Corp. EMC Laboratory
 No.53-11, Tin-Fu Tsun, Lin-kou Hsiang, Taipei
 County, Taiwan R.O.C. Post Code 24443
 Tel:+886-2-26092133 Fax:+886-2-26099303
 Email:ttmc@ttmc.com



AUDIX TECHNOLOGY Corp. EMC Laboratory
 No.53-11, Tin-Fu Tsun, Lin-kou Hsiang, Taipei
 County, Taiwan R.O.C. Post Code 24443
 Tel:+886-2-26092133 Fax:+886-2-26099303
 Email:ttmc@ttmc.com

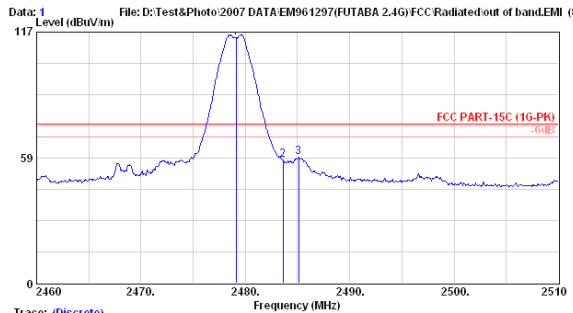

Trace: (Discrete)
 Site no. : A/C Chamber Data no. : 1
 Dis. / Ant. : 3m 3115 Ant. pol. : VERTICAL
 Limit : FCC PART-15C (1G-PK)
 Env. / Ins. : 8593EM 26°C/55% Engineer : Alvin_Yang
 EUT : Radio Control M/N:TMSS2-2.4G
 Power Rating : DC 9.6V
 Test Mode : Stand(CH74)

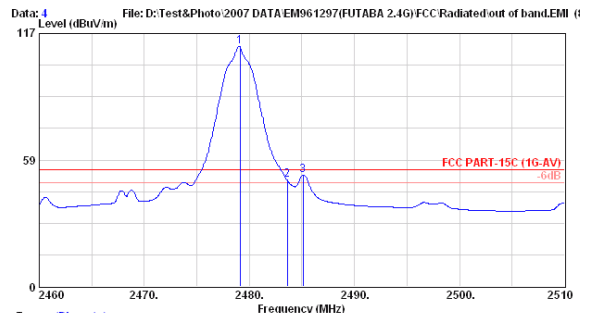

Trace: (Discrete)
 Site no. : A/C Chamber Data no. : 4
 Dis. / Ant. : 3m 3115 Ant. pol. : VERTICAL
 Limit : FCC PART-15C (1G-AV)
 Env. / Ins. : 8593EM 26°C/55% Engineer : Alvin_Yang
 EUT : Radio Control M/N:TMSS2-2.4G
 Power Rating : DC 9.6V
 Test Mode : Stand(CH74)

Freq. (MHz)	Ant. Factor (dB/m)	Cable Loss (dB)	Reading (dBμV)	Emission Level (dBμV/m)	Limits (dBμV/m)	Margin (dB)	Remark
1 2479.104	28.76	6.44	79.05	114.26	74.00	-40.26	Peak
2 2483.600	28.77	6.45	22.02	57.25	74.00	16.75	Peak
3 2485.100	28.77	6.45	23.48	56.71	74.00	15.29	Peak

Remarks: 1. Emission Level= Antenna Factor + Cable Loss + Reading.
 2. The emission levels that are 20dB below the official limit are not reported.

Freq. (MHz)	Ant. Factor (dB/m)	Cable Loss (dB)	Reading (dBμV)	Emission Level (dBμV/m)	Limits (dBμV/m)	Margin (dB)	Remark
1 2479.104	28.76	6.44	75.60	110.80	54.00	-56.80	Average
2 2483.600	28.77	6.45	13.94	49.17	54.00	4.83	Average
3 2485.100	28.77	6.45	16.22	51.45	54.00	2.55	Average

Remarks: 1. Emission Level= Antenna Factor + Cable Loss + Reading.
 2. The emission levels that are 20dB below the official limit are not reported.

4. 6dB BANDWIDTH MEASUREMENT

4.1. Test Equipment

The following test equipment was used during the Emission Bandwidth measurement:

Item	Type	Manufacturer	Model No.	Serial No.	Last Cal.	Next Cal.
1.	Spectrum Analyzer	Agilent	E4446A	US44300366	Aug. 13, 07'	Aug. 12, 08'

4.2. Block Diagram of Test Setup

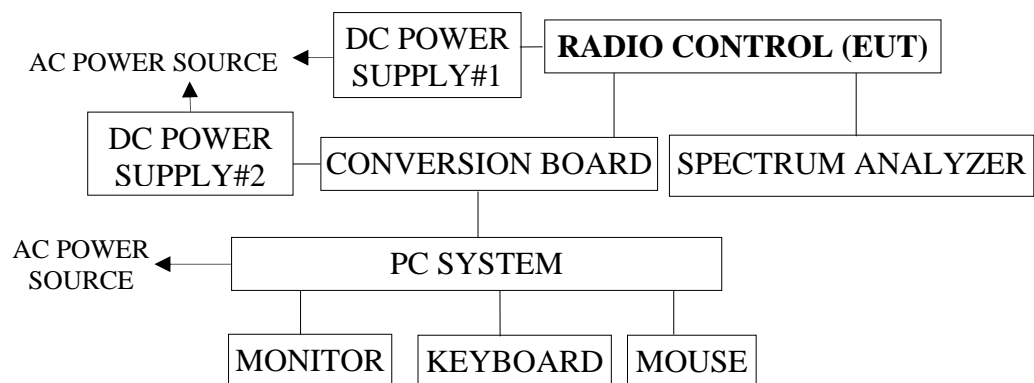

4.3. Specification Limits (§15.247(a)(2))

The minimum 6dB bandwidth shall be at least 500kHz.

4.4. Operating Condition of EUT

The test program “Futaba Term” was used to enable the EUT to transmit data at different channel frequency individually.

4.5. Test Procedure

The transmitter output was connected to the spectrum analyzer. The bandwidth of the fundamental frequency was measure by spectrum analyzer with 100kHz RBW and 100kHz VBW. The 6dB bandwidth is defined as the total spectrum the power of which is higher than peak power minus 6dB.

4.6. Test Results

PASSED. All the test results are attached in next pages.

(Test Date : Sep. 20, 2007 Temperature : 26 Humidity : 55 %)

Channel	Frequency	6dB Bandwidth
0	2405.376MHz	1.73MHz
38	2442.240MHz	1.67MHz
74	2479.104MHz	1.67MHz

Frequency: 2405.376MHz

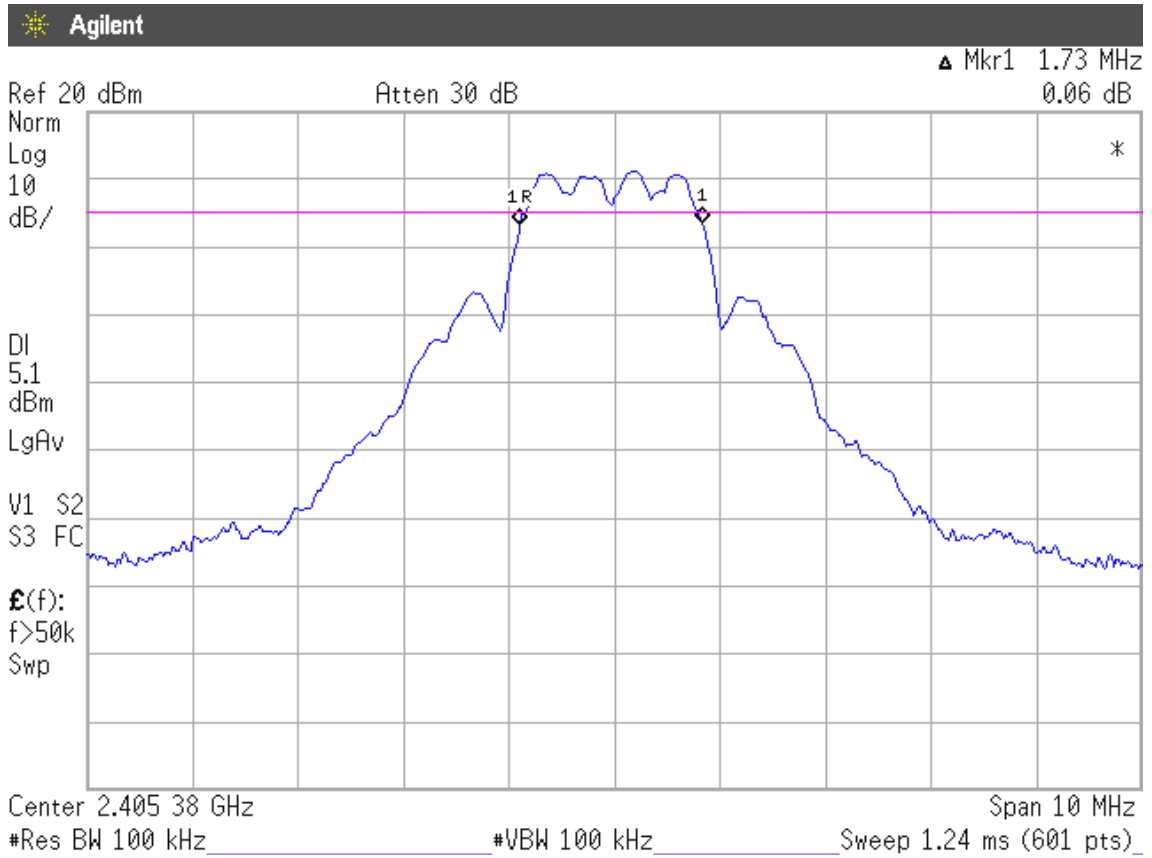

Frequency: 2442.240MHz

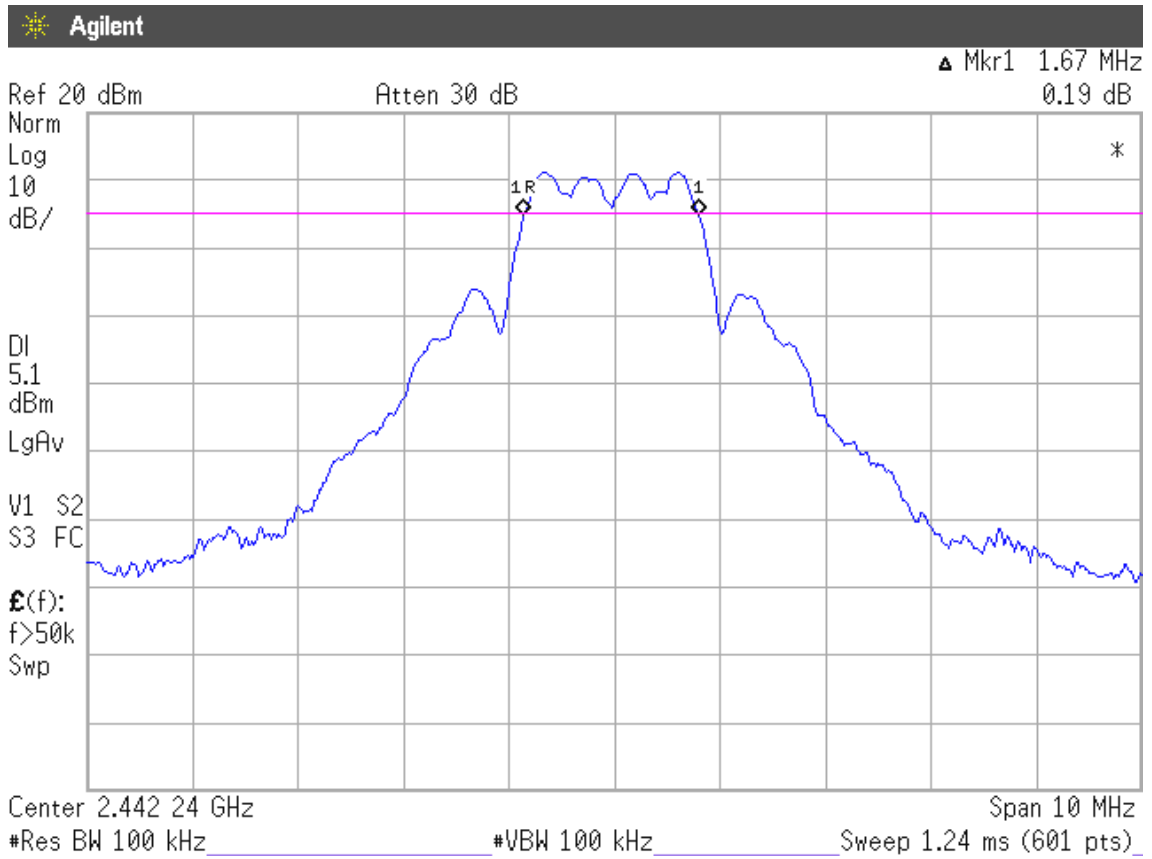

Frequency: 2479.104MHz

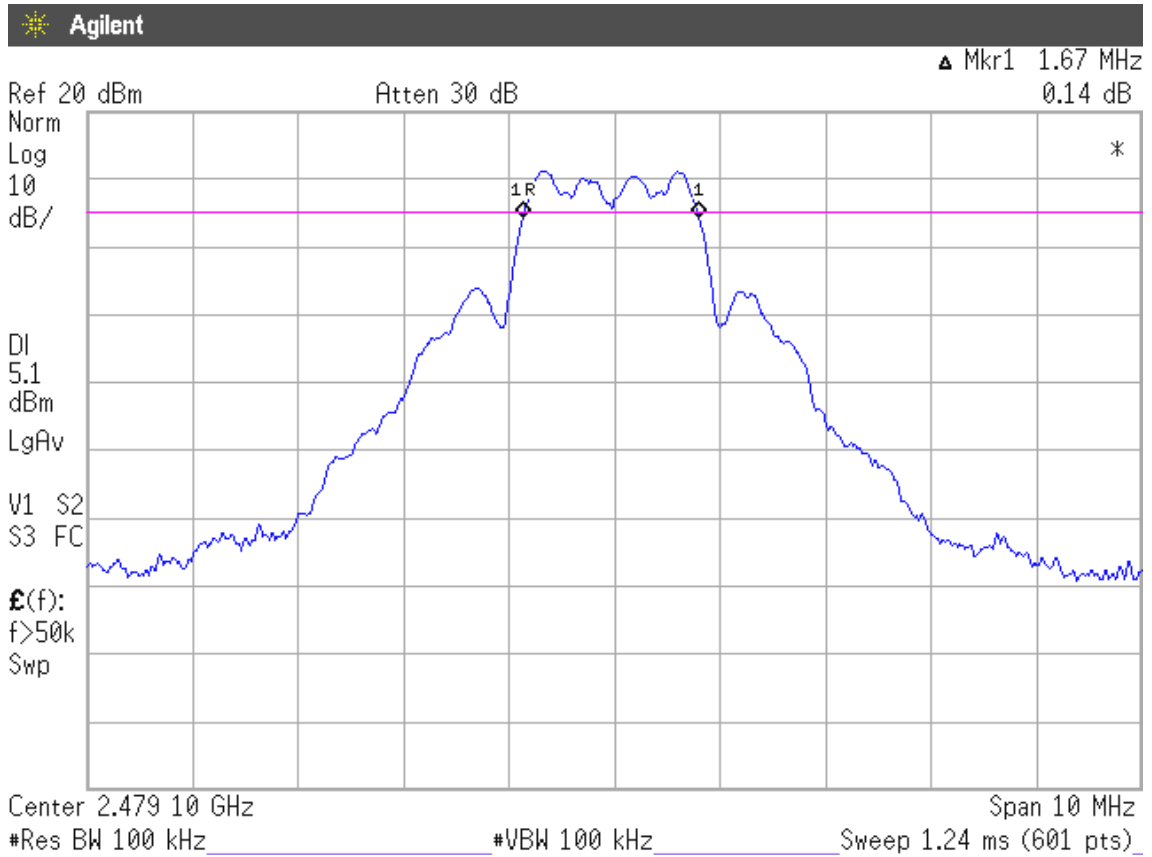

5. MAXIMUM PEAK OUTPUT POWER MEASUREMENT

5.1. Test Equipment

The following test equipment was used during the maximum peak output power measurement:

Item	Type	Manufacturer	Model No.	Serial No.	Last Cal.	Next Cal.
1.	Power Meter	Agilent	E4417A	GB41291797	Feb. 14, 07'	Feb. 13, 08'
2.	Power Sensor	Agilent	E9327A	US40441766	Feb. 14, 07'	Feb. 13, 08'

5.2. Block Diagram of Test Setup

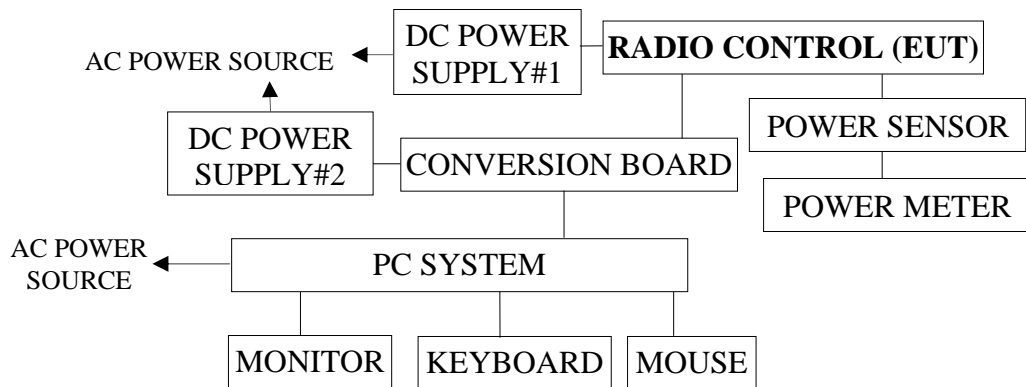

5.3. Specification Limits (§15.247(b)-(3))

The Limits of maximum Peak Output Power for digital modulation in 2400-2483.5MHz is : 1Watt. (30dBm)

5.4. Operating Condition of EUT

The test program “Futaba Term” was used to enable the EUT to transmit data at different channel frequency individually.

5.5. Test Procedure

The transmitter output was connected to the power meter that was designed to detect peak value automatically.

5.6. Test Results

PASSED. All the test results are listed below.

(Test Date : Sep. 20, 2007 Temperature : 26 Humidity : 55 %)

Channel	Frequency	Peak Output Power	Limit
02	2405.376MHz	17.15dBm	30dBm
38	2442.240MHz	17.35dBm	30dBm
74	2479.104MHz	17.16dBm	30dBm

6. EMISSION LIMITATIONS MEASUREMENT

6.1. Test Equipment

The following test equipment was used during the emission limitations test :

Item	Type	Manufacturer	Model No.	Serial No.	Last Cal.	Next Cal.
1.	Spectrum Analyzer	Agilent	E4446A	US44300366	Aug. 13, 07'	Aug. 12, 08'

6.2. Block Diagram of Test Setup

The same as section.4.2.

6.3. Specification Limits (§15.247(c))

In any 100kHz bandwidth outside the frequency band in which the spread spectrum or digitally modulated intentional radiator is operating, the radio frequency power that is produced by the intentional radiator shall be at least 20dB below that in the 100kHz bandwidth within the band that contains the highest level of the desired power, based on either an RF conducted or a radiated measurement. Attenuation below the general limits specified in Section 15.209(a) is not required. In addition, radiated emissions which fall in restricted bands, as defined in Section 15.205(a), must also comply with the radiated emission limits specified in Section 15.209(a) (See Section 15.205(c)).(This test result attaching to §3.6.3)

6.4. Operating Condition of EUT

The test program “Futaba Term” was used to enable the EUT to transmit data at different channel frequency individually.

6.5. Test Procedure

The transmitter output was connected to the spectrum analyzer. The bandwidth of the fundamental frequency was measure by spectrum analyzer with 100kHz RBW and 100kHz VBW.

6.6. Test Results

PASSED. The testing data was attached in the next pages.

(Test Date : Sep. 20, 2007 Temperature : 26 Humidity : 55 %)

1. 2405.376MHz: During 30MHz~25GHz bandwidth. In the 3.19GHz, the -47.27dBm is max value that is lower than 20dB of primary channel.
2. 2442.240MHz: During 30MHz~25GHz bandwidth. In the 1.61GHz, the -41.74dBm is max value that is lower than 20dB of primary channel.
3. 2479.104MHz: During 30MHz~25GHz bandwidth. In the 1.65GHz, the -38.66dBm is max value that is lower than 20dB of primary channel.

Note: The peak above the limit line is the carrier frequency.

Frequency: 2405.376MHz

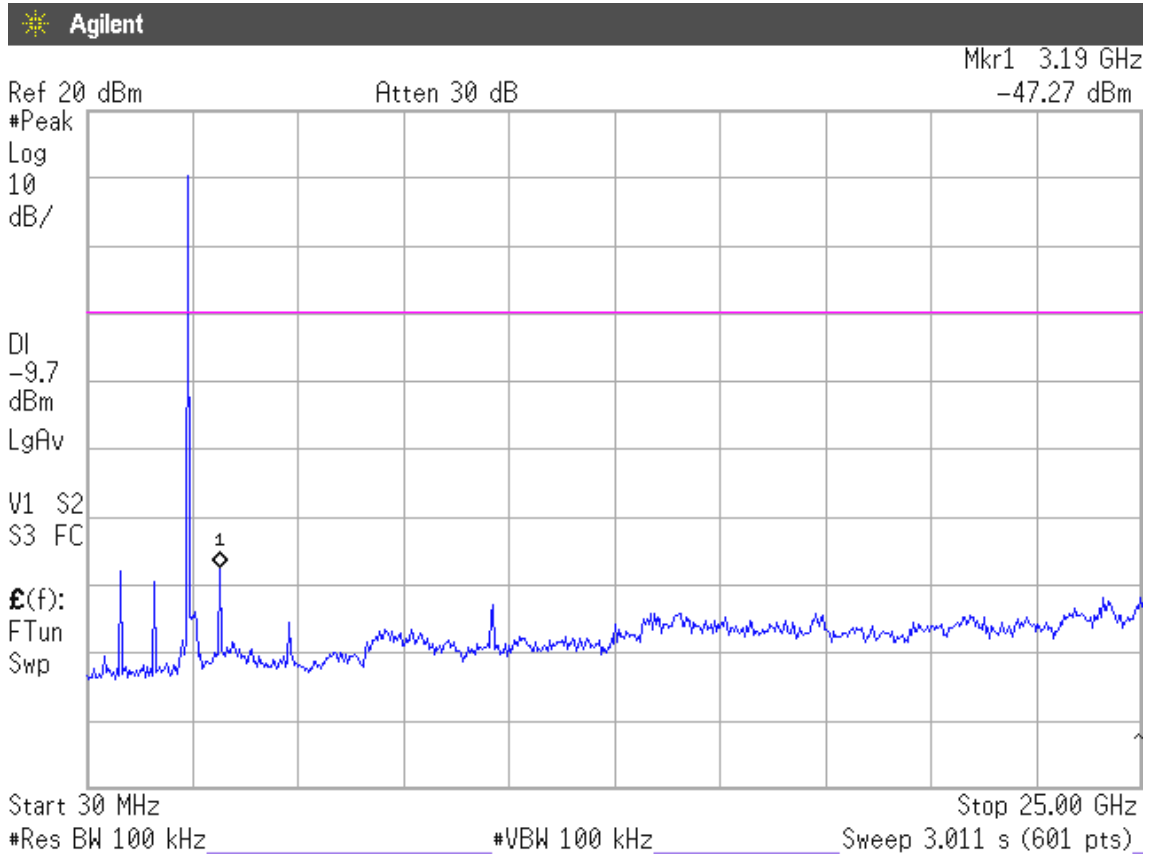

Frequency: 2442.240MHz

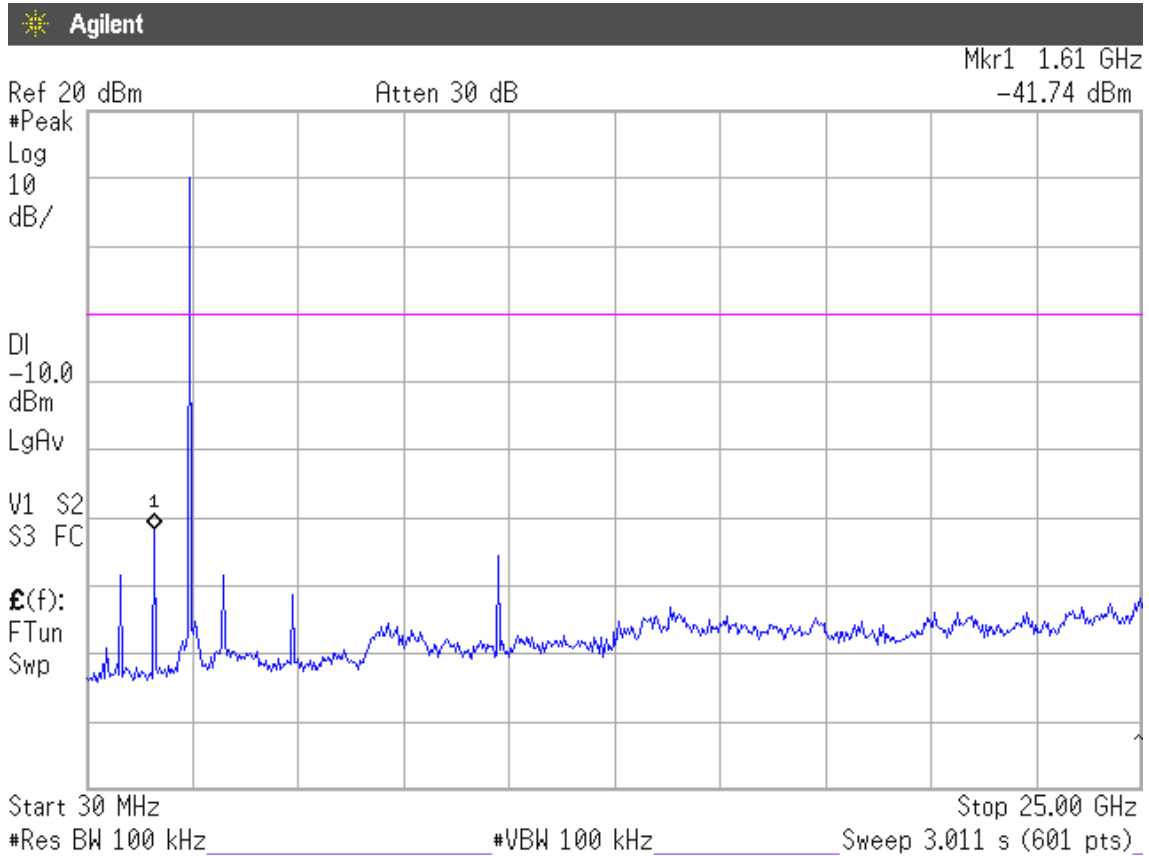

Frequency: 2479.104MHz

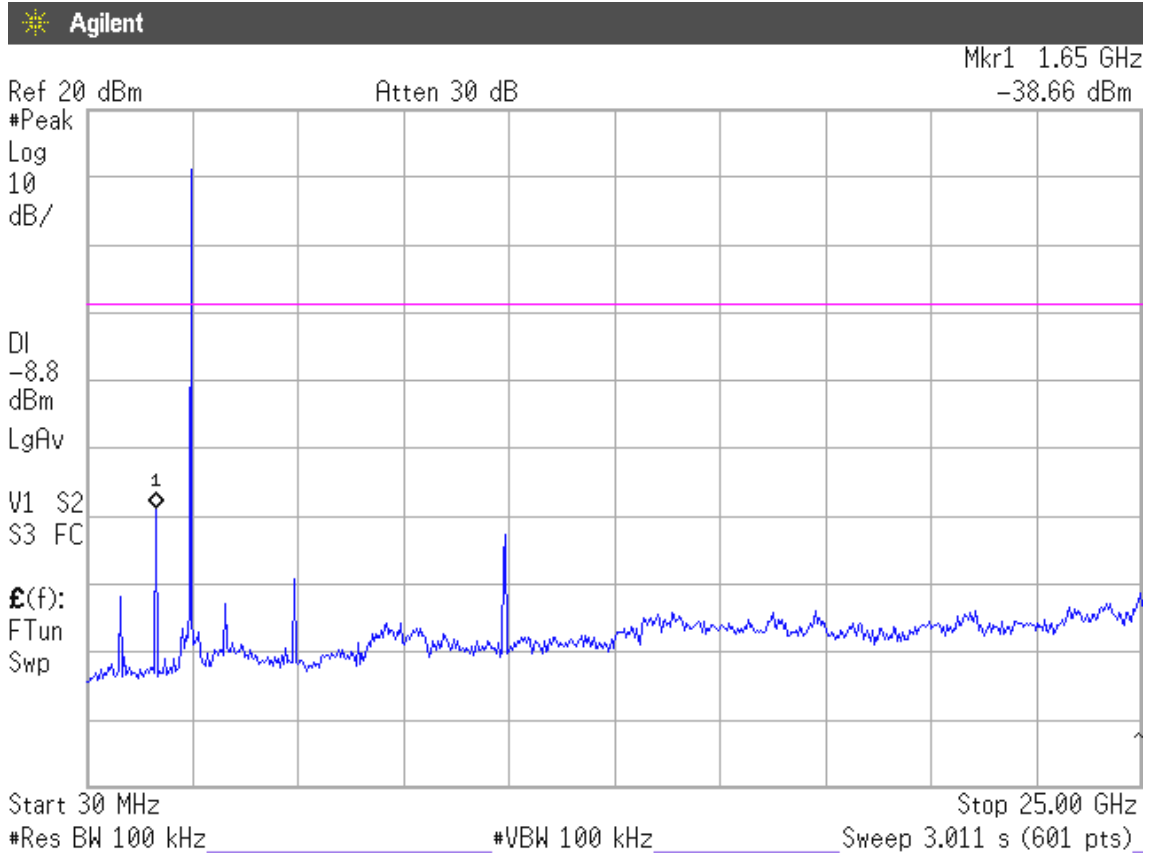

7. BAND EDGES MEASUREMENT

7.1. Test Equipment

The following test equipment was used during the band edges measurement:

Item	Type	Manufacturer	Model No.	Serial No.	Last Cal.	Next Cal.
1.	Spectrum Analyzer	Agilent	E4446A	US44300366	Aug. 13, 07'	Aug. 12, 08'

7.2. Block Diagram of Test Setup

The same as section.4.2.

7.3. Specification Limits (§15.247(c))

The highest level should be at least 20 dB below that in the 100kHz bandwidth.

7.4. Operating Condition of EUT

The test program “Futaba Term” was used to enable the EUT to transmit data at different channel frequency individually.

7.5. Test Procedure

The transmitter output was connected to the spectrum analyzer. Set both RBW and VBW of spectrum analyzer to 100kHz with suitable frequency span including 100kHz bandwidth from band edge.

7.6. Test Results

PASSED. All the test results are attached in next pages.

(Test Date : Sep. 20, 2007 Temperature : 26 Humidity : 55 %)

1. Below Band edge: The highest emission level is -47.92dBm on 2.48367GHz .
2. Upper Band edge : The highest emission level is -45.74dBm on 2.39983GHz .

Below Band edge

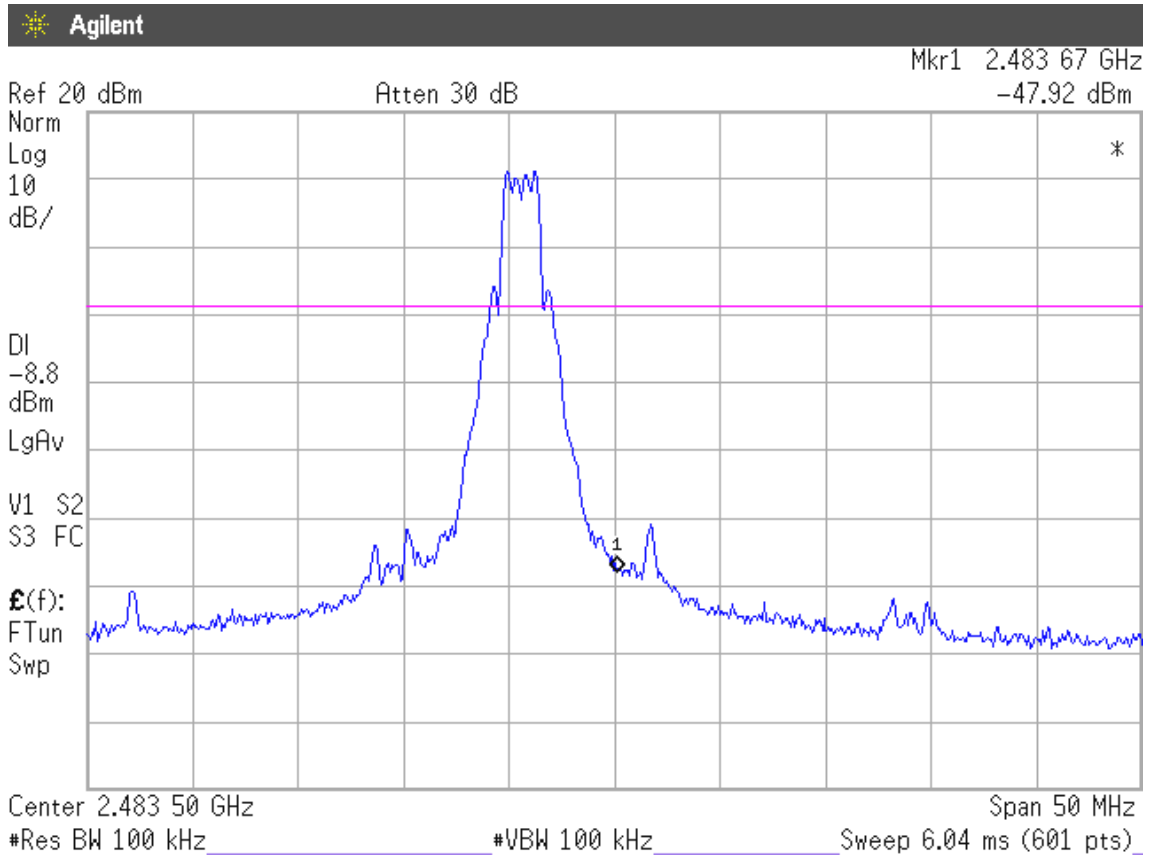

Upper Band edge

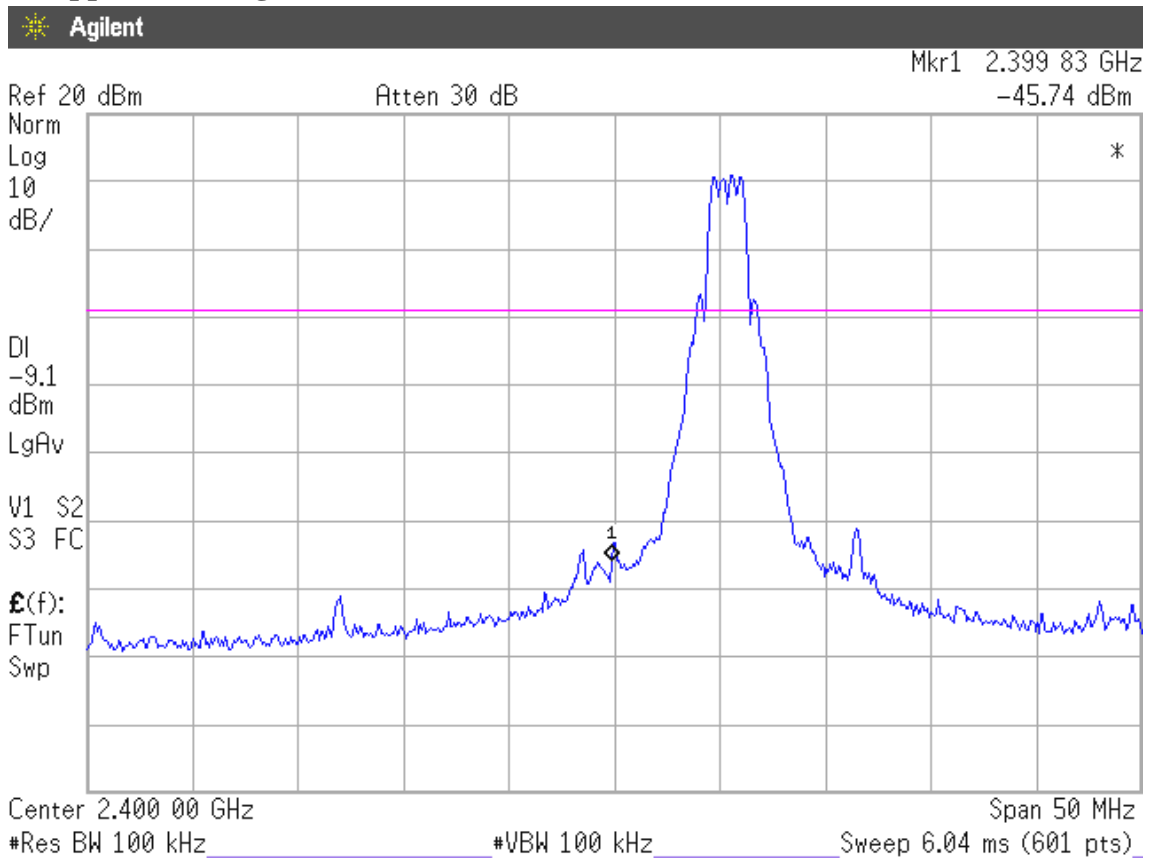

8. POWER SPECTRAL DENSITY MEASUREMENT

8.1. Test Equipment

The following test equipment was used during the power spectral density measurement:

Item	Type	Manufacturer	Model No.	Serial No.	Last Cal.	Next Cal.
1.	Spectrum Analyzer	Agilent	E4446A	US44300366	Aug. 13, 07'	Aug. 12, 08'

8.2. Block Diagram of Test Setup

The same as section.4.2.

8.3. Specification Limits (§15.247(d))

The peak power spectral density conducted from the intentional radiator to the antenna shall not be greater than 8dBm in any 3kHz band.

8.4. Operating Condition of EUT

The test program “Futaba Term” was used to enable the EUT to transmit data at different channel frequency individually.

8.5. Test Procedure

The transmitter output was connected to the spectrum analyzer. The bandwidth of the fundamental frequency was measured with the spectrum analyzer using 3kHz RBW and 30kHz VBW, set sweep time = span/300kHz.

8.6. Test Results

PASSED. All the test results are attached in next pages.

(Test Date : Sep. 20, 2007 Temperature : 26 Humidity : 55 %)

Channel	Frequency	Power Spectral Density	Limit
02	2405.376MHz	2.57dBm	8dBm
38	2442.240MHz	2.37dBm	8dBm
74	2479.104MHz	3.33dBm	8dBm

Frequency: 2405.376MHz

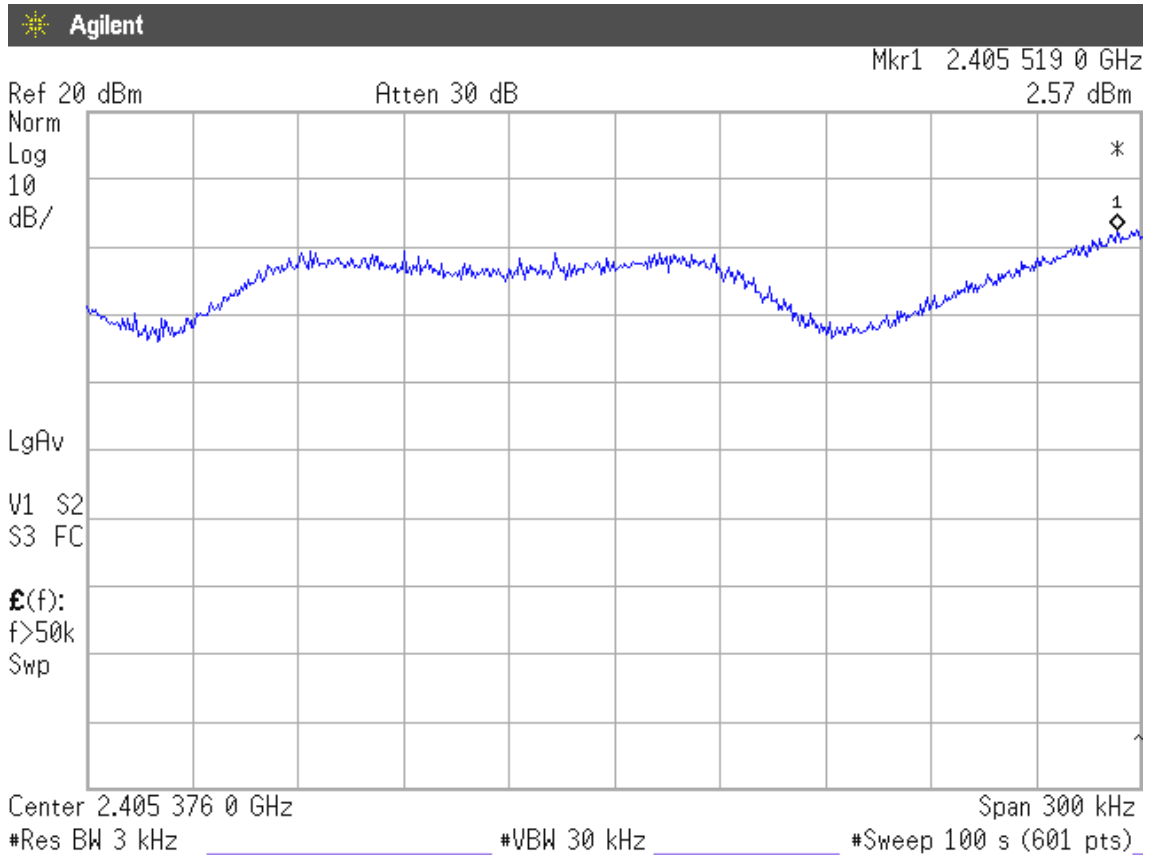

Frequency: 2442.240MHz

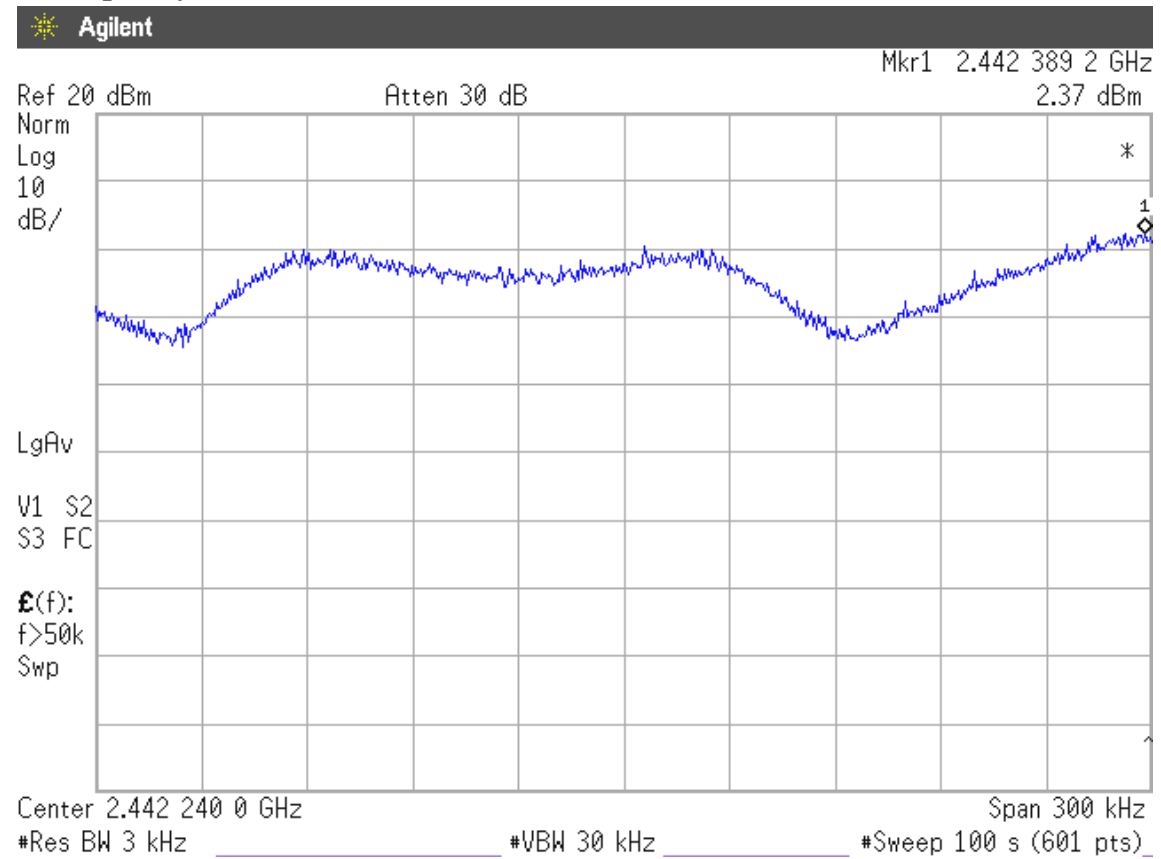

Frequency: 2479.104MHz

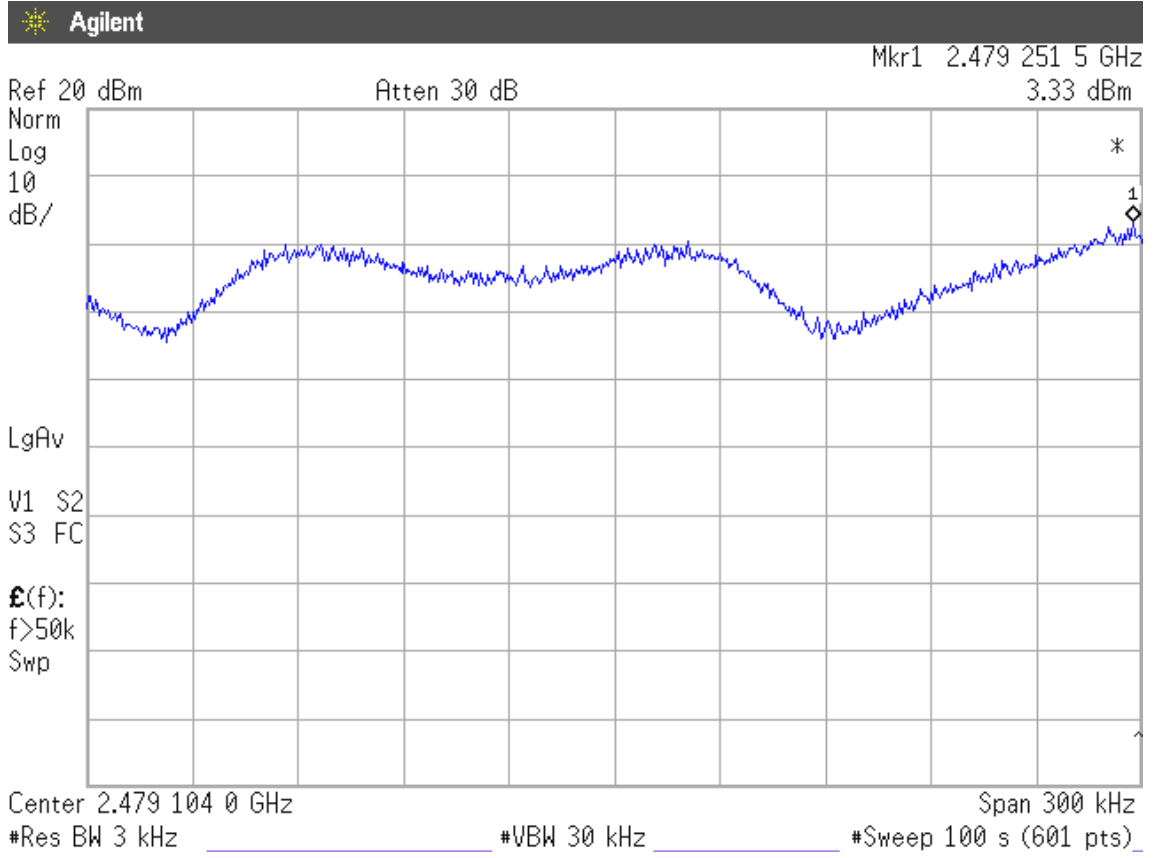

9. DEVIATION TO TEST SPECIFICATIONS

【NONE】