



***EMC Measurement / Technical Report***

***FCC Test Specification*** : FCC Part 95, Subpart C  
Radio Control (R/C) Radio Service

***Equipment Authorization*** : Certification

***Manufacturer*** : Futaba Corporation of America

***Equipment Under Test*** : T7YFK  
72 – 76 MHz Radio Control Transmitter

***Test Report No.*** : FR1111

***Purchase Order No.*** : Verbal P.O.

***Document History***

<b><i>Revision</i></b>	<b><i>Issue Date</i></b>	<b><i>Affected Pages</i></b>	<b><i>Description of Modifications</i></b>	<b><i>Revised By</i></b>	<b><i>Approved By</i></b>
N/C	19 May, 1999		Initial release		



# EMC Measurement / Technical Report

## Document No. FR1111

From



**Garwood Laboratories, Inc.**  
**World Compliance Division**

Test for

**Futaba Corporation of America**

**T7YFK**

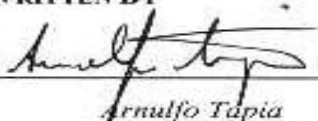
**72 – 76 MHz Radio Control Transmitter**

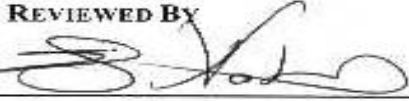
<b>WRITTEN BY</b>  <i>Arnulfo Tapia</i> EMC Technician	<b>REVIEWED BY</b>  <i>Robert Lynch</i> Quality Manager	<b>REVIEWED BY</b>  <i>Ed Nakauchi</i> EMC Chief Engineer NARTE, Certified
--	---	---

<b>Test Personnel</b>	<b>Test Dates</b>
Arnulfo Tapia- EMC Technician	7,11 May 1999

<b>Test Facility</b>	Garwood Laboratories, Inc.-OC
<b>Address</b>	565 Porter Way
<b>City, State, Zip Code</b>	Placentia, CA 92870
<b>Phone</b>	(714) 572-2027
<b>Fax</b>	(714) 572-2025

This report may be reproduced in full, partial reproduction may only be made with the written consent of the laboratory.  
The results in this report apply only to the equipment tested.  
This report may not be used to claim product endorsement by NVLAP or any agency of the U.S. government.



**TABLE OF CONTENTS**

**MEASUREMENT/TECHNICAL REPORT SUMMARY**..... 4

**1. GENERAL INFORMATION**..... 5

    1.1 *Product Description*..... 5

    1.2 *Configuration of Tested System* ..... 5

    1.3 *Test Facility*..... 6

**2. TECHNICAL INFORMATION**..... 7

    2.1 *Circuit Diagram* ..... 7

    2.2 *Function of Each Active Device*..... 7

    2.3 *Tune-up Alignment Procedure* ..... 7

    2.4 *Frequency Stabilization Circuitry* ..... 7

    2.5 *Additional Circuit Information* ..... 8

**3. PRODUCT LABELING** ..... 9

    3.1 *FCC ID Label*..... 9

    3.2 *Location of Label on EUT*..... 9

    3.3 *Information to the User*..... 9

**4. BLOCK DIAGRAMS OF EUT**..... 10

**5. TEST RESULTS** ..... 11

    5.1 *RF Power Output* ..... 11

    5.2 *Occupied Bandwidth*..... 12

    5.3 *Field Strength of Spurious Radiation* ..... 13

    5.4 *Frequency Stability* ..... 15

**6. PHOTOGRAPHS OF TEST ARRANGEMENTS & EUT CONSTRUCTION** ..... 18

**APPENDIX A - TEST EQUIPMENT USED**..... 26

**APPENDIX B -SUPPLEMENTAL TEST DATA** ..... 27

**ATTACHMENTS**..... 30



**MEASUREMENT / TECHNICAL REPORT SUMMARY**

<b>Manufacturer Company</b> <b>Address</b> <b>City, State, Zip</b> <b>Country</b> <b>Contact Name</b> <b>Phone</b> <b>Fax</b>	Futaba Corporation of America 4 Studebaker Irvine, CA 92718 USA Steve Helms (949) 455-9888 (949) 455-9899
<b>Type of Authorization</b>	Certification for 72 – 76 MHz R/C Transmitter
<b>Applicable FCC Rules</b>	PART 95 – PERSONAL RADIO SERVICES Prepared in accordance with the requirements of FCC Rules and Regulations as listed in 47 CFR Ch.1 (10-1-96 Edition). The following subparts are applicable to the results in this test report: Part 95, Subpart C - Radio Control (R/C) Radio Service Part 95, Subpart E - Technical Regulations Part 2, Subpart J – Equipment Authorization Procedures The test data presented in this report has been acquired using the guidelines set forth in FCC Part 2, §2.981 through §2.1005 and Part 95. The test results presented in this document are valid only for the equipment identified herein under the test conditions described. Repeatability of these test results will only be achieved with identical measurement conditions. The unit is battery operated; therefore, conducted emission measurements are not applicable.
<b>Equipment Under Test</b>	72 – 76 MHz Radio Control Transmitter
<b>Identification of EUT</b>	Model: T7YFK FCC ID: AZPT7YFK-72
<b>Production Quantity</b>	Multiple Units

<b>EMC Test Laboratory</b> <b>Facility</b> <b>Address</b> <b>City, State, Zip Code</b> <b>Country</b> <b>Contact Name</b> <b>Title</b> <b>Phone</b> <b>Fax</b>	Garwood Laboratories Incorporated World Compliance Division 565 Porter Way Placentia, CA 92870 USA Jason Armstrong General Manager (714) 572-2027 (714) 572-2025
--	--

**1. General Information**



### 1.1 Product Description

<b><i>Equipment Under Test</i></b>	72 – 76 MHz Radio Control (R/C) Transmitter
<b><i>Model Number</i></b>	T7YFK
<b><i>Description</i></b>	The EUT is a 72 – 76MHz 6-channel radio control transmitter for aircraft and surface craft operation. The transmitter portion of the T7YFK operates in the frequency range of 72.010 – 72.990 MHz for aircraft operation or 75.410 – 75.990 MHz for car/boat operation. The transmitting power of the EUT is less than 750mW.
<b><i>Clock Frequencies</i></b>	6 MHz ,72.550 MHz or 75.690 MHz

### 1.2 Configuration of Tested System

The following table lists all of the components of the tested system. FCC ID numbers are included if available for a tested system component.

<b>Tested System Details</b>					
<i>Item</i>	<i>Manufacturer</i>	<i>Description</i>	<i>Model No.</i>	<i>Serial No.</i>	<i>FCC ID</i>
EUT	Futaba Corporation	R/C Transmitter	T7YFK	N/A	AZPT7YFK-72

The Equipment Under Test (EUT) was tested as a stand-alone unit. The EUT contains an integral antenna, which was extended to its maximum length during the test. The control settings on the EUT were adjusted to the middle or center position. During the field strength measurements, the 9.6VDC Ni-Cd battery was fully charged.

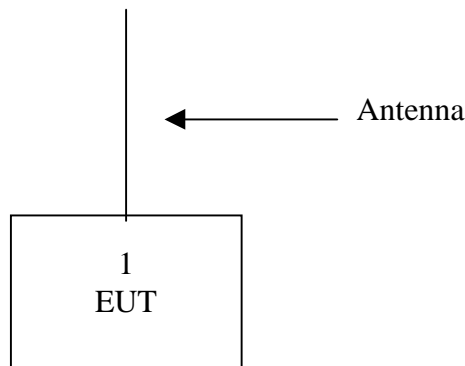



### 1.3 Test Facility

The open area test site (OATS) and measurement facilities used to collect the test data are located at Garwood Laboratories, Inc. World Compliance Division test facility in Placentia, CA. This facility has been fully described in a report submitted to the FCC and accepted in a letter dated 29 January 1999 (31040/SIT 1300F2) registration #90681.

**The test facility is also recognized and accredited from following accreditation organizations:**

<b>Acemark Europe, Ltd.</b>	Laboratory Number: 0007 <i>ISO Guide 25, EN45001, and relevant parts of ISO 9002</i>	Dated: 03/17/97
<b>Industry Canada</b>	Reference: IC 3298	Dated: 03/11/99
<b>I<sup>2</sup>T</b> <i>(Interference Tech International)</i>	Certificate Number: 99-051 CE Mark for European Country	Dated: 05/05/99
<b>NVLAP</b> <i>(NIST)</i>	NVLAP Lab Code: 200119-0 CISPR, FCC, AUSTEL	Effective Through 12/31/99
<b>VCCI</b>	Registration #'s C574, C575, C576, R561	Effective Through 02/04/00
<i>(Voluntary Control Council for Interference by Information Technology Equipment)</i>		



## 2. Technical Information

<i>Type of Emission</i>	8K00F1D
<i>Frequency Range</i>	72-76MHz
<i>Range of Operating Power</i>	Fixed Output Power
<i>Maximum Output Power</i>	321mW – 75MHz, 250mW – 72MHz
<i>FCC Rating Maximum Transmitting Power</i>	750mW
<i>Final Stage Amplifier DC Voltage, Current</i>	Voltage: 9.6VDC Current: 75mA

### 2.1 Circuit Diagram

Refer to the Circuit Schematic in the Attachment section of this report.

### 2.2 Function of Each Active Device

1. Q1 (2SC1009A) – Oscillator and Multiplier
2. Q2 (2SC3772) – Driver
3. Q3 (2SC4272) – Final Stage RF Amplifier
4. Q5 (2SC2412) – Waveform shaper
5. Q6 (2SC2412) – Trainer Buffer
6. Q7 (2SC2412) – Trainer Buffer
7. IC1 (FP6324) – Encoder
8. IC2 (BU4051) – Encoder
9. IC3 (78L05) – Voltage Stabilizer

### 2.3 Tune-up Alignment Procedure

1. L1, L2, L3, L4, L5, & L6 tune to generate the maximum power.
2. Repeat 1 again.
3. Turn the core of L6 C.W. to 1/8.

### 2.4 Frequency Stabilization Circuitry

1. D3 (RLZ5, 1B) – Zener diode to regulate the supply voltage of the oscillator.
2. Crystal – Stabilizes oscillating frequency.
3. C1 (UJ 68pF) – Temperature compensation capacitor.
4. C2 (RH 100pF) – Temperature compensation capacitor.
5. C3 (RH 39pF) – Temperature compensation capacitor.

### 2.5 Additional Circuit Information



1. The type of oscillator utilized by the EUT is a Crystal controlled modified Colpitts oscillator.
2. The following components are used for suppression of spurious radiation from the antenna:
  - $\pi$  Filter
    - L5, L6 (7GD0005)
    - C16 (RH 47pF)
    - C17 (RH 18pF)
    - C19 (RH 56pF)
    - C21 (CH 47pF)
3. Audio Low Pass Filter
  - C27 (2.2 $\mu$ F)
  - C28 (1nF)
  - Q5 (2S2412)
  - R18 (10k $\Omega$ )
  - R19 (10k $\Omega$ )
  - R20 (10k $\Omega$ )
4. No Digital Modulation technique was employed. No Phase Locked Loop circuitry was used.





### 3. Product Labeling

#### 3.1 FCC ID Label

<b>FCC ID: AZPT7YFK-72</b> <b>FUTABA</b> <b>MADE IN TAIWAN</b>
--

#### 3.2 Location of Label on the EUT



#### 3.3 Information to the User

The users manual or instruction manual for an intentional or unintentional radiator shall caution the user that changes or modifications not expressly approved by the party responsible for compliance could void the user's authority to operate the equipment.



4. BLOCK DIAGRAM(S) OF EUT

Printed Circuit Board TA24 T7YFK Block Diagram

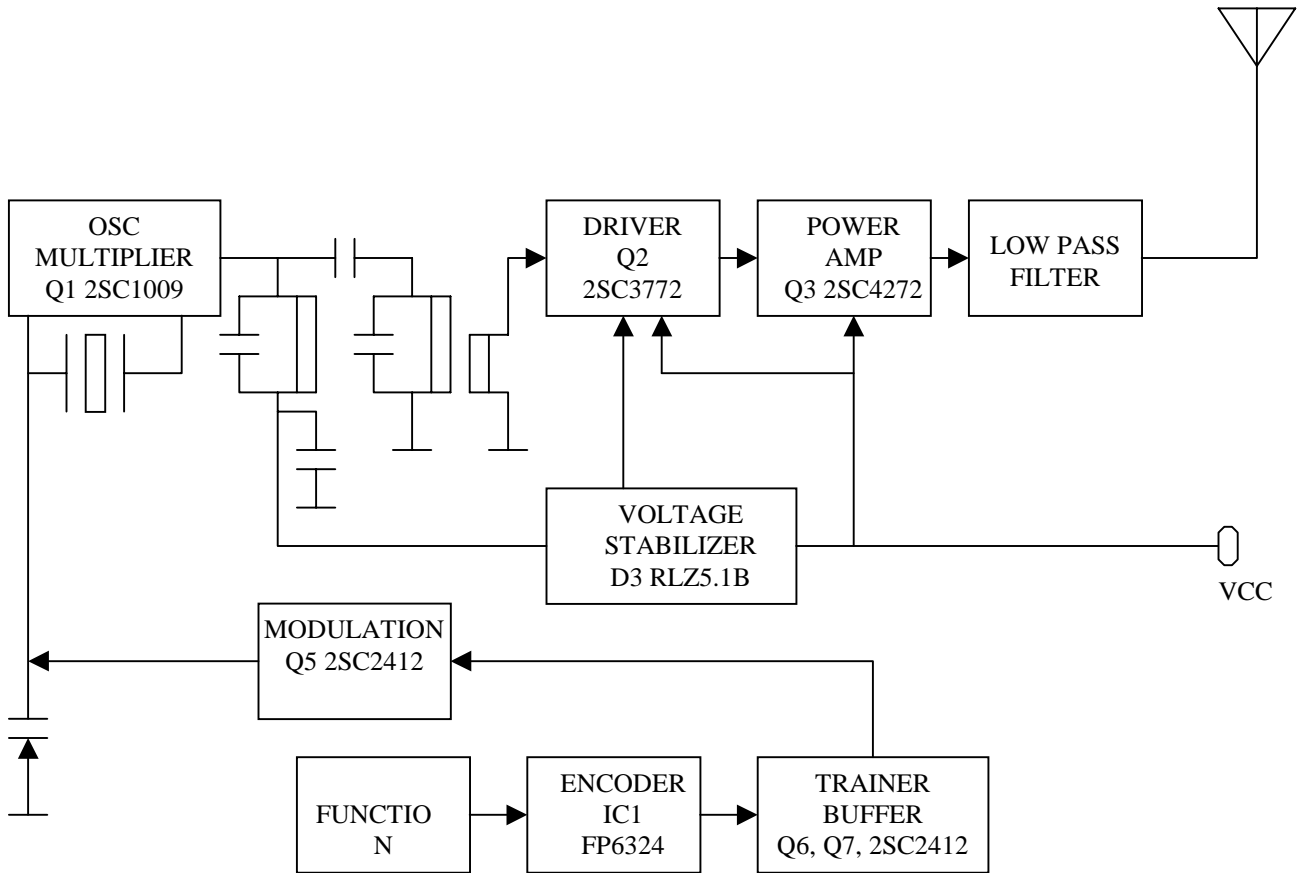



## 5. TEST RESULTS

### 5.1 RF Power Output

The output power was found by measuring the field strength of the transmitter in the open area test site and converting the field strength in volts/meter to transmitter power (EIRP) in watts. The field strength was measured at a distance of 3 meters. The following formula was used to convert the field strength (FS) in volts/meter to transmitter output power (TP) in watts:

$$TP = (FS \times D)^2 / (30 \times G),$$

where D is the distance in meters between the two antennas and G is the antenna numerical gain referenced to isotropic gain. The integral antenna of the EUT is assumed to have a gain of one, G=1. The output power should not exceed 750mW, for an R/C transmitter operating in the frequency band of 72 – 76MHz.

#### Results:

The measured field strength at 72.550 MHz was 119.2 dB $\mu$ V/m at a distance of 3 meters. The transmitter output power (EIRP) in watts was calculated to be 250mW.

The measured field strength at 75.690 MHz was 120.3 dB $\mu$ V/m at a distance of 3 meters. The transmitter output power (EIRP) in watts was calculated to be 321mW.



## **5.2 Occupied Bandwidth**

As stated in 47 CFR 2.989, the occupied bandwidth is the frequency bandwidth such that, below its lower and above its upper frequency limits, the mean powers radiated are each equal to 0.5 percent of the total mean power radiated by a given emission. The occupied bandwidth measurements were made with the modulating signal. The authorized bandwidth for any emission type transmitted by and R/C transmitter is 8kHz. The test result plots are enclosed in Appendix B of this report.



### 5.3 Field Strength of Spurious Radiation

Measurements were made to detect unwanted emissions. The EUT was placed 80 centimeters above the ground plane on a non-conductive tabletop 1.0-meter width by 1.5-meter length. The configuration of the EUT and its cables were varied to maximize the amplitude level of the emissions. The highest emissions were maximized by rotating the turntable 360 degrees and varying the antenna height from 1 to 4 meters. The frequency range up to the 10<sup>th</sup> harmonic was measured utilizing a BiLog antenna, and the measurements were made in both vertical and horizontal polarization. The distance between the EUT and the measuring antenna was 3 meters. The power of unwanted emissions should be less than the transmitter power (TP) by at least  $56 + 10 \log (TP)$  dB on any frequency removed from the center of the authorized bandwidth by more than 250%. The following table contains the results:

Tuned Frequency: 72.550 MHz  
Measurement Distance: 3m  
FCC Limit:  $119.2 - (56 + 10 \log 0.250)$   
= 69.2dB $\mu$ V

<i>Frequency of Emission (MHz)</i>	<i>Emission Level (dB<math>\mu</math>V)</i>	<i>Correction Factor* (dB)</i>	<i>Corrected Reading (dB<math>\mu</math>V/m)</i>	<i>FCC Limit @ 3 meters (dB<math>\mu</math>V)</i>	<i>Delta to FCC limit (dB)</i>
72.550	134.9	-15.7	119.2	-	-
145.100	74.8	-8.6	66.2	69.2	-3.0
217.650	61.4	-10.7	50.7	69.2	-18.5
290.200	45.7	-6.9	38.8	69.2	-30.4
362.750	52.3	-3.8	48.5	69.2	-20.7
435.300	45.0	-2.1	42.9	69.2	-26.3
507.850	40.6	-0.8	39.8	69.2	-29.4
580.400	40.1	0.8	40.9	69.2	-28.3
652.950	45.3	2.6	47.9	69.2	-21.3
725.500	43.6	4.8	48.4	69.2	-20.8

- The Correction Factor consist of Antenna Factor + Cable Loss – Preamplifier Gain.
- Measurements were performed with both vertical and horizontal antenna polarization. Vertical antenna polarization measurements were worst case.



**Garwood Laboratories, Inc. - World Compliance Division**  
*Electromagnetic Compatibility*

Tuned Frequency: 75.690 MHz  
Measurement Distance: 3m  
FCC Limit:  $120.3 - (56 + 10\log 0.321)$   
= 69.2dB $\mu$ V

<b><i>Frequency of Emission (MHz)</i></b>	<b><i>Emission Level (dB<math>\mu</math>V)</i></b>	<b><i>Correction Factor* (dB)</i></b>	<b><i>Corrected Reading (dB<math>\mu</math>V/m)</i></b>	<b><i>FCC Limit @ 3 meters (dB<math>\mu</math>V)</i></b>	<b><i>Delta to FCC limit (dB)</i></b>
75.690	135.1	-14.8	120.3	-	-
151.380	72.6	-8.5	64.1	69.2	-5.1
227.070	64.7	-10.4	54.3	69.2	-14.9
302.760	47.2	-6.4	40.8	69.2	-28.4
378.450	54.7	-3.4	51.3	69.2	-17.9
454.140	47.0	-1.8	45.2	69.2	-24.0
529.830	34.3	-0.3	34.0	69.2	-35.2
605.520	39.8	1.8	41.6	69.2	-27.6
681.210	47.0	3.6	50.6	69.2	-18.6
756.900	35.0	5.3	40.3	69.2	-28.9

- The Correction Factor consist of Antenna Factor + Cable Loss – Preamplifier Gain.
- Measurements were performed with both vertical and horizontal antenna polarization. Vertical antenna polarization measurements were worst case.



#### 5.4 Frequency Stability

The EUT's carrier frequency stability is the ability of the transmitter to maintain an assigned carrier frequency over the variations of extreme ambient temperature and supply voltage.

The EUT was placed in a temperature chamber. The temperature was set to the lowest requirement, -30°C, and there was a waiting period of at least 2 hours, until a stable temperature was reached inside the EUT. A frequency measurement was made once a period of time sufficient enough to stabilize all of the components of the oscillator circuit elapsed. The temperature was then increased by 10°C increments. Again, sufficient time was allowed to elapse in order to stabilize the components of the oscillator circuit, and then a frequency was measurement was made. This was done until the maximum requirement, +50°C, was reached. The following table contains the results:

#### Frequency Stability vs. Temperature

Frequency tuned: 75.690 MHz

Frequency Accuracy Required: 0.002%

<i>Operating Temperature (°C)</i>	<i>Frequency Measured (MHz)</i>	<i>Frequency Deviation (Hz)</i>	<i>Frequency Deviation (%)</i>
-30	75.689924	-76	-0.000100
-20	75.690229	229	0.000303
-10	75.690345	345	0.000456
0	75.690473	473	0.000624
+10	75.690394	394	0.000521
+20	75.690217	217	0.000287
+30	75.689964	-36	-0.000048
+40	75.689816	-184	-0.000244
+50	75.689653	-348	-0.000459



### Frequency Stability vs. Temperature

Frequency tuned: 72.550 MHz  
Frequency Accuracy Required: 0.002%

<i>Operating Temperature (°C)</i>	<i>Frequency Measured (MHz)</i>	<i>Frequency Deviation (Hz)</i>	<i>Frequency Deviation (%)</i>
-30	72.550126	126	0.000173
-20	72.550443	443	0.000611
-10	72.550501	501	0.000690
0	72.550426	426	0.000586
+10	72.550339	338	0.000467
+20	72.550141	141	0.000194
+30	72.549871	-129	-0.000178
+40	72.549688	-312	-0.000430
+50	72.549505	-495	-0.000682

### Frequency Stability vs. Supply Voltage

Frequency stability was measured with variation of primary supply voltage. For battery powered equipment, the primary supply voltage was reduced to the battery operating end point. The following table contains the results:

Frequency Tuned: 75.690 MHz      Frequency Accuracy Required: 0.002%  
Normal Input Voltage: 9.6VDC      Temperature: 20°C

<i>Input Voltage (V)</i>	<i>Frequency Measured (MHz)</i>	<i>Frequency Deviation (Hz)</i>	<i>Frequency Deviation (%)</i>
7.68	75.689733	-267	-0.000353
8.00	75.689803	-197	-0.000261
8.50	75.689881	-119	-0.000157
9.00	75.689937	-63	-0.000084
9.60	75.689984	-16	-0.000021
10.00	75.690006	6	0.000008
10.50	75.690029	29	0.000038
11.00	75.690047	46	0.000061
11.52	75.690062	62	0.000082





**Frequency Stability vs. Supply Voltage**

Frequency Tuned: 72.550 MHz      Frequency Accuracy Required: 0.002%  
Normal Input Voltage: 9.6VDC      Temperature: 20°C

<i>Input Voltage (V)</i>	<i>Frequency Measured (MHz)</i>	<i>Frequency Deviation (Hz)</i>	<i>Frequency Deviation (%)</i>
7.68	72.549741	-259	-0.000358
8.00	72.549802	-198	-0.000273
8.50	72.549867	-133	-0.000184
9.00	72.549913	-87	-0.000121
9.60	72.549950	-50	-0.000069
10.00	72.549969	-31	-0.000043
10.50	72.549986	-14	-0.000019
11.00	72.550000	0	-0.000001
11.52	72.550009	9	0.000012



## 6. Photographs of Test Arrangement and EUT Construction

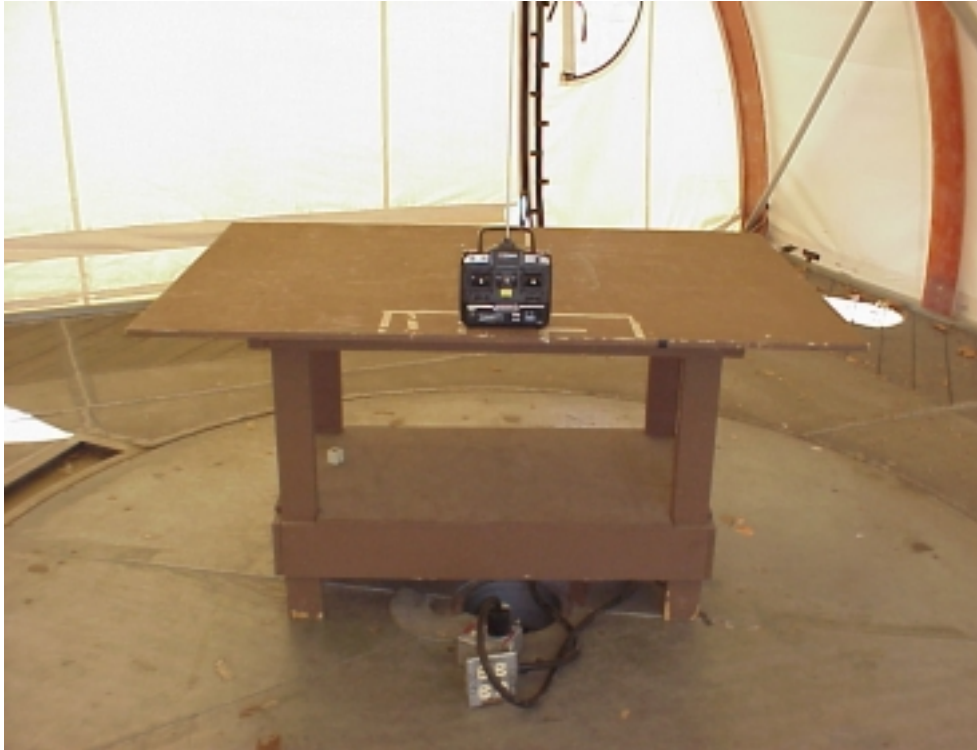

6.1 Field Strength of Spurious Radiation



6.2 Field Strength of Spurious Radiation



6.3 EUT Construction Front View (72 & 75 MHz Units)



6.4 EUT Construction Front View



6.5 EUT Construction Top View



6.6 EUT Construction Back View



6.7 EUT Construction Side View

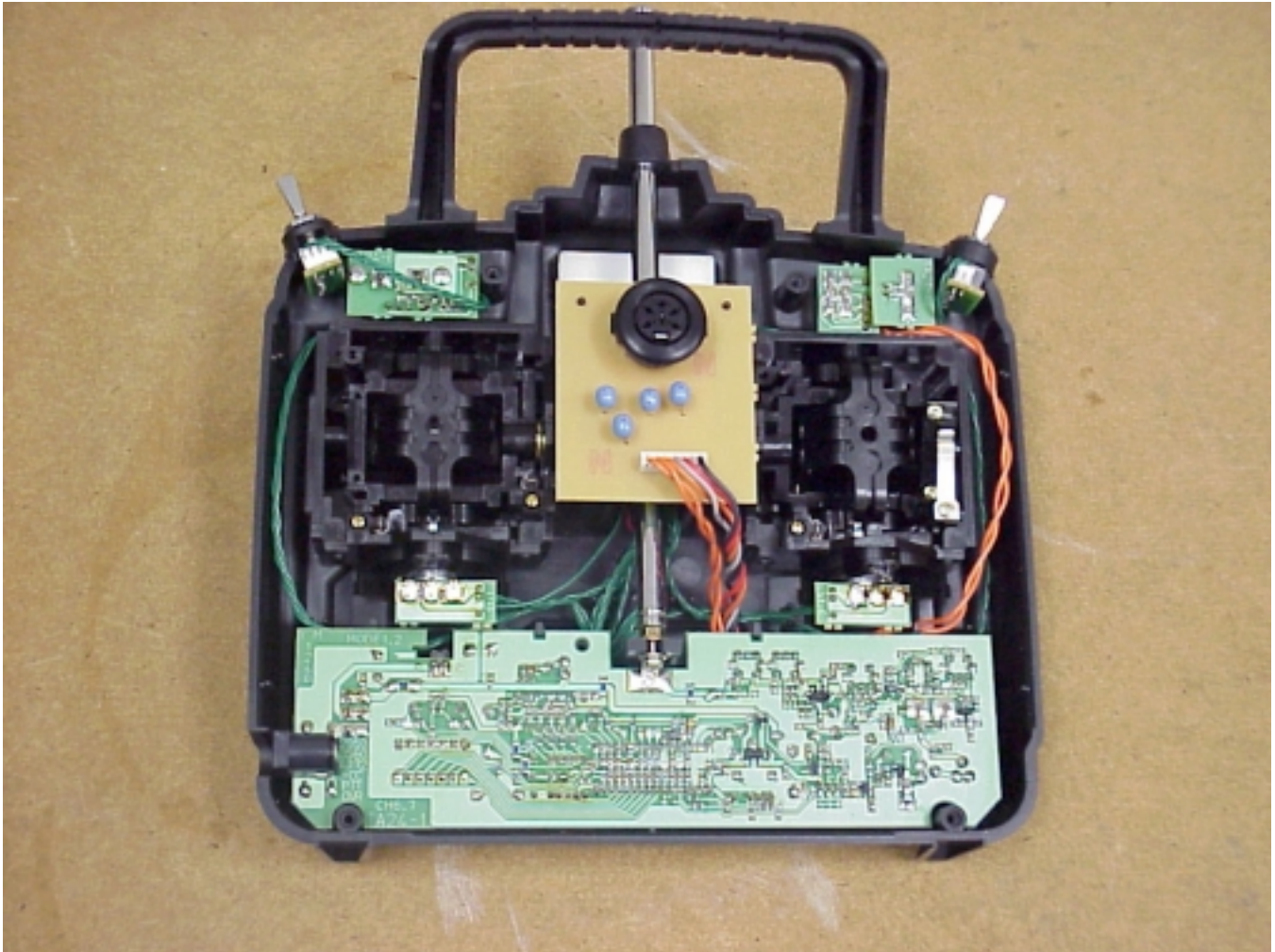

6.8 EUT with Enclosure Removed

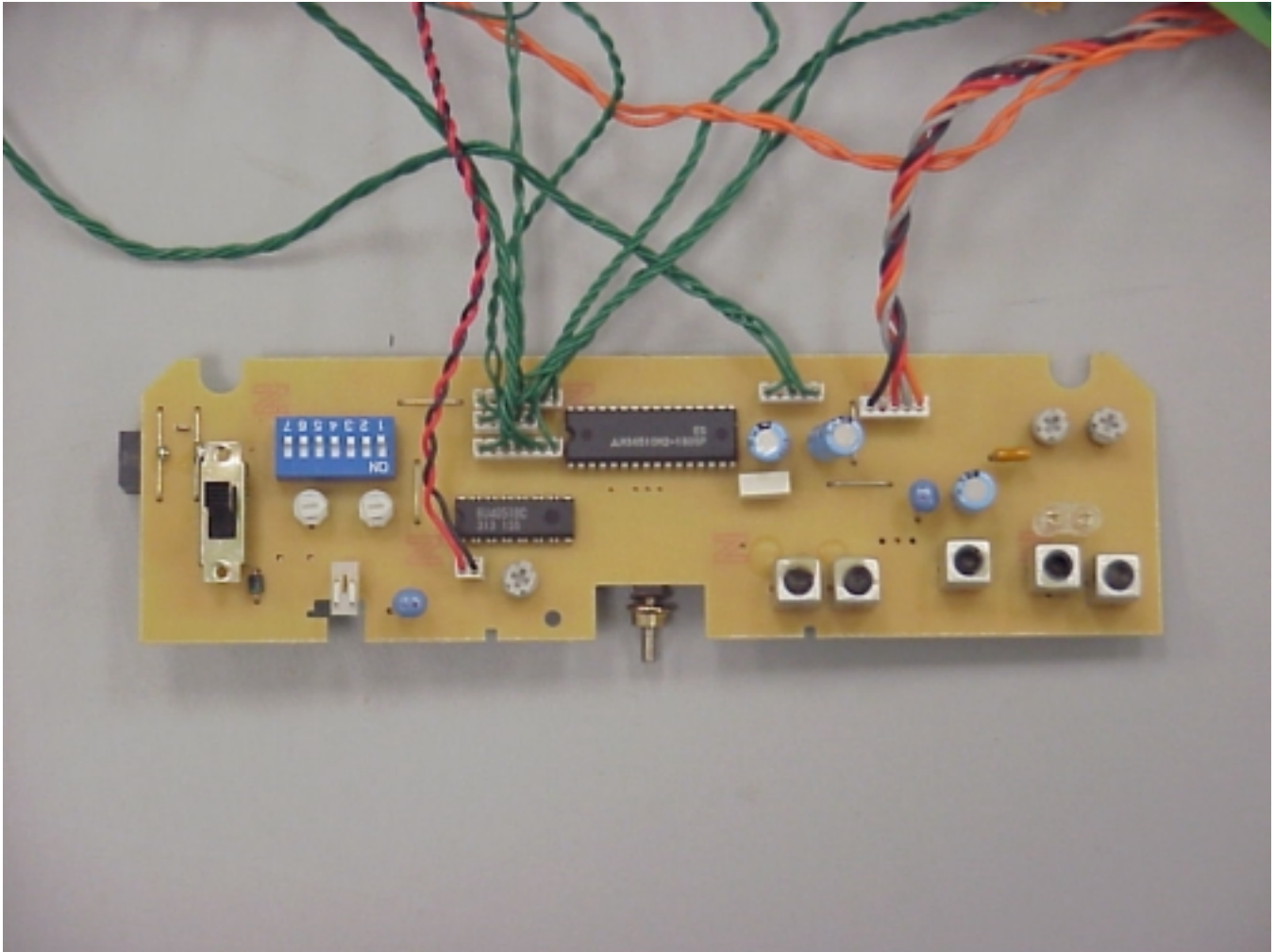

6.9 EUT PCB Layout and/or Components Side(1)

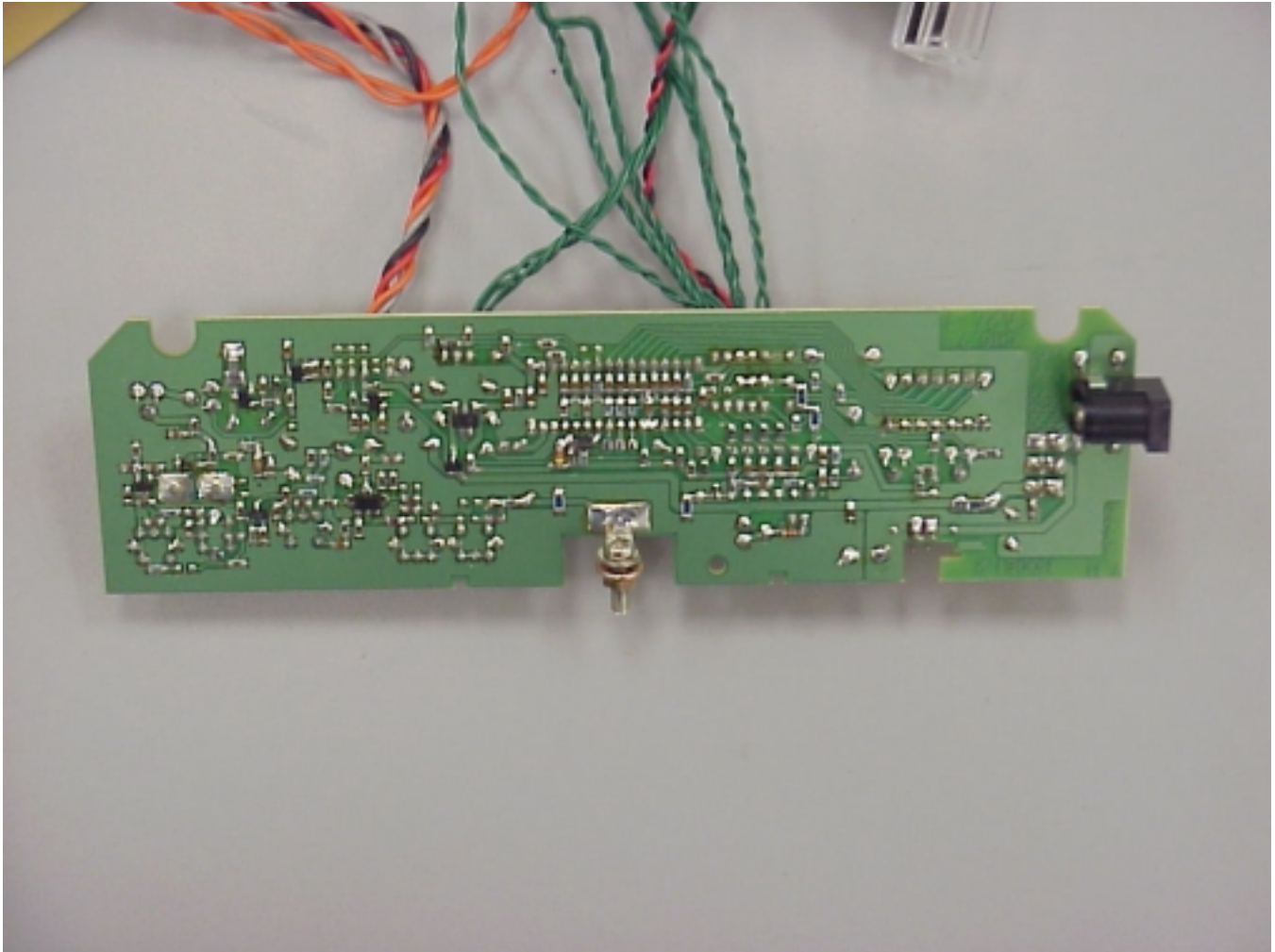

6.10 EUT PCB Layout and/or Component Side (2)



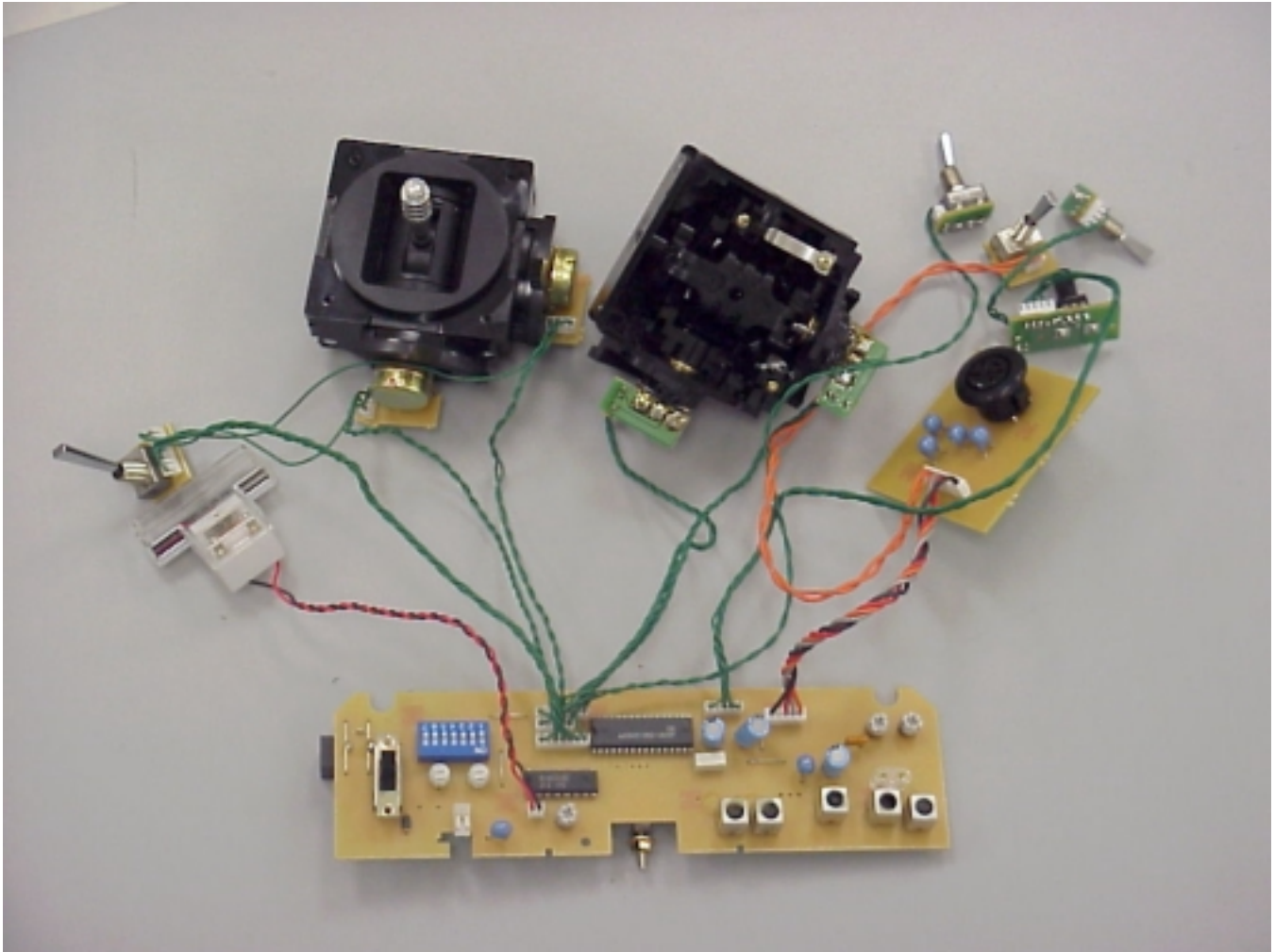

6.11 EUT PCB Layout and/or Component Side (3)



**APPENDIX A - TEST EQUIPMENT USED**

The absolute performance calibration, of the equipment requiring calibration, is performed on an as needed basis in accordance with MIL-STD-45662A. However, calibration periods do not exceed one (1) year. The test equipment is capable of making measurements within tolerances of at least +/- 2 dB amplitude and +/-2% frequency deviation. Equipment certifications showing traceability to NIST (National institute of Standards and Technology) are maintained on file at Garwood Laboratories, Inc. Placentia, CA. All equipment is checked and verified for proper operation before and after each series of tests.

**A.1 Specific Equipment Used**

<i>Test Instrument</i>	<i>Mfg / Model No.</i>	<i>Serial No.</i>	<i>Cal. Due Date</i>
<b>Radiated Emissions Test</b>			
Spectrum Analyzer	Hewlett Packard / 8568B	2007A01154	10/14/99
Pre-Selector	Hewlett Packard / 85685A	3010A01156	10/14/99
Quasi-Peak Adapter	Hewlett Packard / 85650A	2412A00400	10/14/99
BiLog Antenna	Chase / CBL6111A	1823	04/12/00
Preamplifier (30-1000MHz)	ISCI / ZFL-2000	017	03/05/00
RF Coax Cable	Times Microwave / LMR-600	030	03/05/00
High Pass Filter	Mini-Circuits / NHP-100	N/A	10/10/99
High Pass Filter	Mini-Circuits / NHP-250	N/A	10/10/99



**APPENDIX B – SUPPLEMENTAL TEST DATA**

<i>Basic Standard</i>	<i>Test Type</i>	<i>Data Format</i>	<i>Page No.</i>
Part 95 Subpart C, E Part 2 Subpart J	Occupied Bandwidth 72.550 MHz	Plotted	B1
	Occupied Bandwidth 75.690 MHz	Plotted	B2

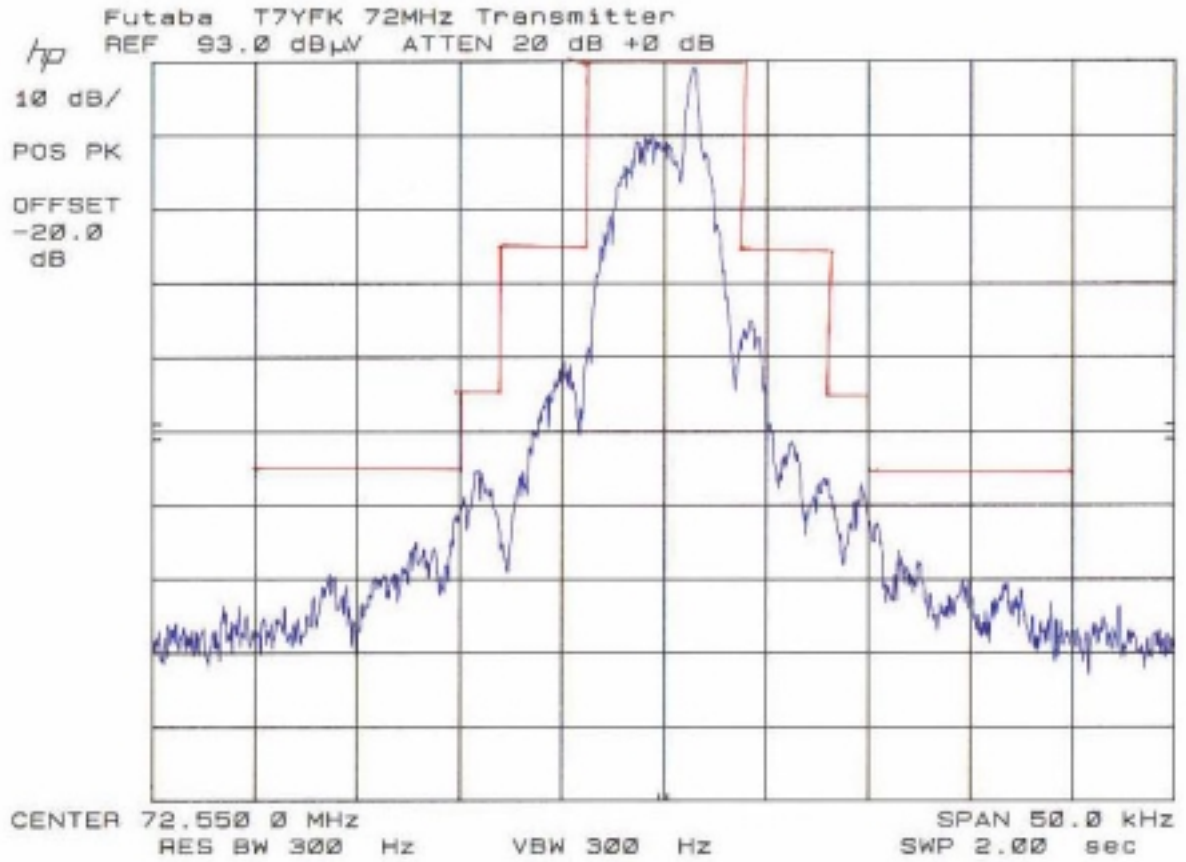

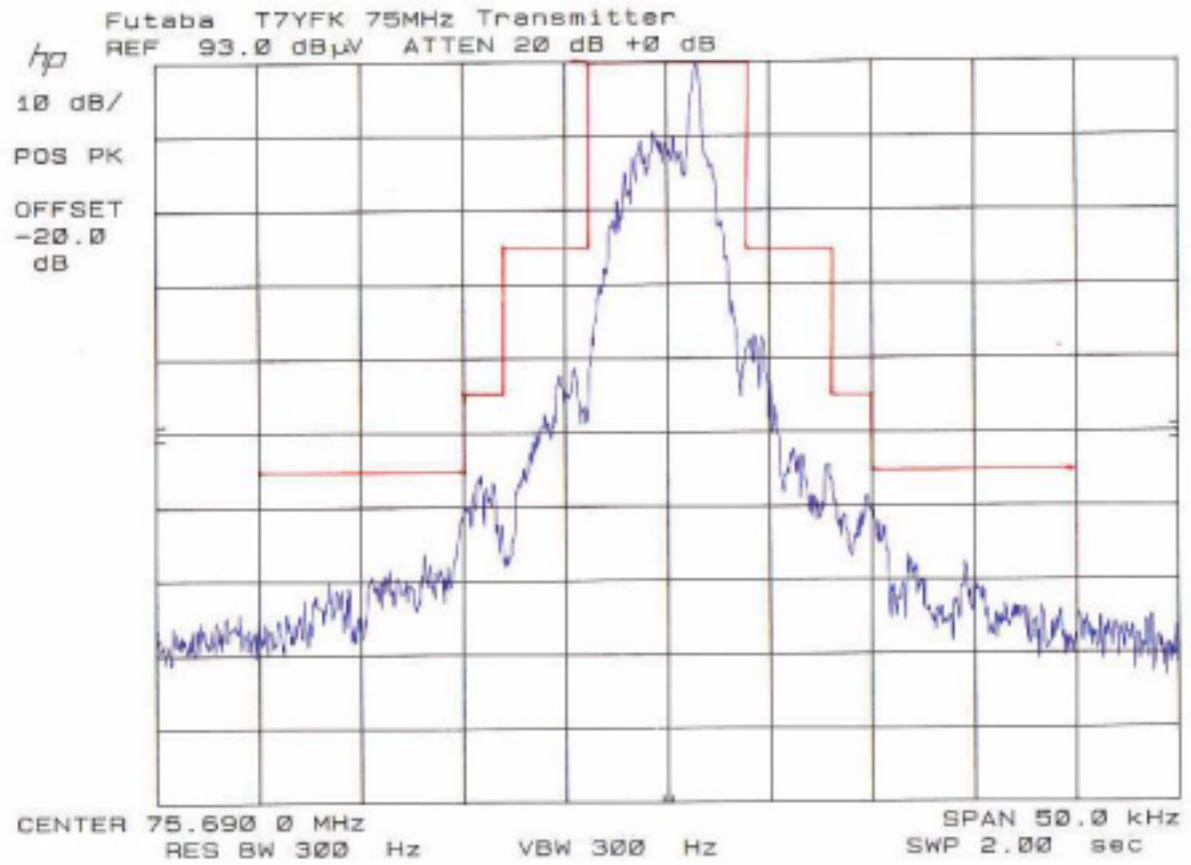



## ATTACHMENTS

### INDEX OF ATTACHMENTS

<i>Description of Contents</i>	<i>Page No.</i>
Circuit Schematics	Exhibit A
PCB Layout Drawing Solder Side	Exhibit B
PCB Layout Drawing Parts Side	Exhibit C
Preliminary Instruction Manual	Exhibit D