

**For cars only**

*Before using your new 3PM 2.4GHz system, please read this manual thoroughly and use the system properly and safely. After reading this manual, store it in a safe place.*



**3PM 2.4GHz System**

**About this guide**  
 This manual is supplement to the separate "3PM INSTRUCTION MANUAL". Refer to the "3PM INSTRUCTION MANUAL" for the basic operating instructions. In the programming mode, refer to the programming instructions of the 3PM-FM system.  
 This guide describes the new functions and the safety precautions of the 3PM 2.4GHz system.

Thank you for purchasing a 3PM 2.4GHz system. This system is based on the combination of the newly developed 2.4GHz transmitter and its correspondent receiver. The system utilizes the 2.4GHz-SS radio communication and an ultra small antenna. In addition, the system inherits Futaba's unique HRS (High Response System).

**Features**

- 2.4GHzSS (Spread Spectrum) radio communication system
- Frequency channel setting unnecessary: Sifting the channels within the 2.4GHz band automatically, this system minimizes the interference from other 2.4GHz system.
- Accepts no unwanted signals by using ID code
- The function "Auto-Detect" is utilized to automatically determine which mode is active, HRS or PPM mode. (R603FS)
- Short and small antenna (T3PK-2.4G)/Diversity antenna (R603FS)

- No part of this manual may be reproduced in any form without prior permission.
- The contents of this manual are subject to change without prior notice.
- This manual has been carefully written. Please write to Futaba if you feel that any corrections or clarifications should be made.

**INSTRUCTION MANUAL**

**Contents and Technical Specifications**

Your 3PM 2.4GHz system includes the following components;

	<b>3PM 2.4GHz system</b>
Transmitter	<b>T3PM-2.4G</b>
Receiver	<b>R603FS</b>
Servo	-----
Miscellaneous	Transmitter battery holder Receiver switch Mini screwdriver Instruction manual

**[Specification]**

- Communication method: One-way operation system
  - Mode: PPM, HRS (Auto-detect)
  - Maximum operating range: 80m (Optimum condition)
  - For safety: F/S, B-F/S, ID (About 4billion ways of pair identifications)
- Transmitter T3PM-2.4G;**  
 (Wheel system, 3 channels)
- Transmitting frequency: 2.4GHz band
  - Power requirement: (NiCd battery) NT8F700B(9.6V), (Dry cell battery) Penlight x 8(12V)
  - Current drain: 250mA or less
  - Transmission antenna: 1/2λ mono-pole
- Receiver R603FS;**
- Reception antenna: Diversity type (Two antennas: internal and external)
  - Power requirement: 6V Nicd battery
  - DSC function available
  - RS232C port: (for factory use only)
  - Size: 39x26x14mm (excluding a projection part)
  - Weight: 14.1g

**Installing the T3PK-2.4G/R603FS**

Install and adjust the T3PK-2.4G transmitter and R603FS receiver as described below.

**Adjustment of the antenna direction**

**⚠ WARNING**

Adjust the antenna vertically to the ground. Otherwise, the operating range may become shorter.



**(Antenna Moving Range)**

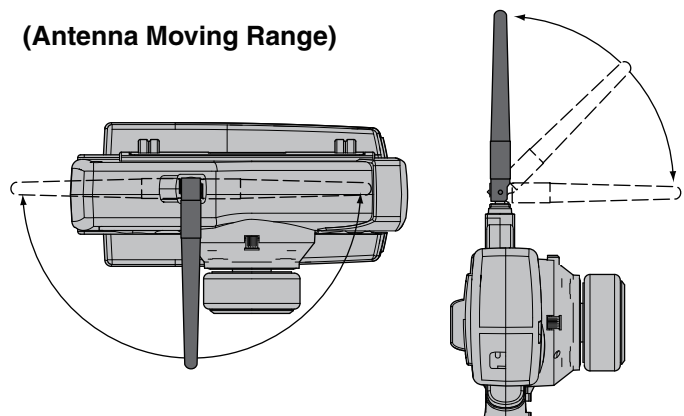

## Receiver installation

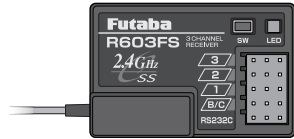

**R603FS Receiver**

- 1 Install the R603FS receiver on the car as follow;

**Note:** The operating range may become shorter, although depending on where the receiver and the antenna are mounted.

### ⚠ WARNING

- ❗ Install the antenna in the higher place as shown in the figure.
- 🚫 Do not cut the antenna.
- ❗ Keep the antenna away from the motor, ESC and other noise sources as possible as you can.
- ❗ Put the antenna in the antenna tube to protect it.
- 🚫 Do not bend the coaxial cable. It causes damage.
- ❗ Wrap the receiver with something soft such as foam rubber to avoid vibration. If there is a chance of getting wet, put the receiver in a waterproof bag or balloon to avoid water.

### ⚠ CAUTION

- ❗ Always use R603FS under the following conditions;
    - Power supply; 6V Nicd battery (PPM/HRS mode)
    - Servo; 6V type Futaba Digital Servo (HRS mode)
- \* If the conditions are different, control is impossible or the servo may be damaged.

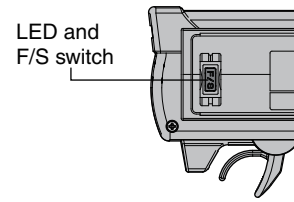
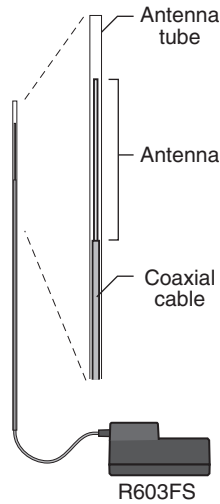

**Note:** Check the LED on the rear of the transmitter.

Parameter check for 0.5 seconds after power-on	Red: On
Transmitting signals	Green: On
F/S is activated by the F/S switch of the transmitter. (PPM mode)	Green: Blink
Unrecoverable failure (EEPROM, etc.)	Red and Green turn on alternatively.

- 3 Turn on the receiver.

- 4 Push the tactile switch of the receiver.

**Note:** Check the LED of the receiver.

No signal reception	Red : On
Receiving signals	Green: On
Receiving signals, but ID is unmatched.	Green: Blink
Unrecoverable failure (EEPROM, etc.)	Red and Green turn on alternatively.

## How to Set the F/S Position

### PPM mode only:

\*HRS mode: Set the F/S function by the fail safe function menu.

- 1 Move and hold the throttle trigger (stick) to the F/S servo position where you want to set (slow side) then push the F/S switch on the transmitter.

The LED blinks green.

**Note:** Always set again when turning on the power.

## How to turn on the power

A certain ID number is given to the receiver automatically. Identifying this ID number, the system will minimize the interference from other transmitters.

- 1 Bring the transmitter and the receiver close to each other within one meter.
- 2 Turn on the transmitter.

## Battery F/S function

The Battery F/S function becomes active when the voltage of the receiver becomes 4.75V or less. The throttle servo move to the preset F/S position.

### Usage Precaution

#### ⚠ WARNING

- ❗ Special attention should be paid before turning on the system while other cars are running or other airplanes are flying because the 2.4GHz RC system could potentially affect them.

#### ⚠ WARNING

- ❗ Be sure to set the Fail Safe function.

### Repair Service

Before requesting repair, read this instruction manual again and recheck your system. Should the problem continue, request repair service as follows:

Describe the problem in as much detail as possible and send it with a detailed packing list together with the parts that require service.

- Symptom (Including when the problem occurred)
- System (Transmitter, Receiver, Servo's and model numbers)
- Model (Model name)
- Model Numbers and Quantity
- Your Name, Address, and Telephone Number.

If you have any questions regarding this product, please consult your local hobby dealer or contact the Futaba Service Center.

### Special Markings;

Pay special attention to the safety at the parts of this manual that are indicated by the following marks.

[Symbol] ; Prohibited ; Mandatory

Mark	Meaning
	Procedures which may lead to a dangerous condition and cause death or serious injury to the user if not carried out properly.
	Procedures which may lead to a dangerous condition or cause death or serious injury to the user if not carried out properly, or procedures where the probability of superficial injury or physical damage is high.
	Procedures where the possibility of serious injury to the user is small, but there is a danger of injury, or physical damage, if not carried out properly.

# INSTRUCTIONS MANUAL

## FEDERAL COMMUNICATIONS COMMISSION

### INTERFERENCE STATEMENT

This equipment has been tested and found to comply with the limits for a Class B digital device, pursuant to Part 15 of the FCC Rules. These limits are designed to provide reasonable protection against harmful interference in a residential installation. This equipment generates, uses, and can radiate radio frequency energy and, if not installed and used according to the instructions, may cause harmful interference to radio communications. However, there is no guarantee that interference will not occur in a particular installation. If this equipment does cause harmful interference to radio or television reception, which it found by turning the equipment off and on, the user is encouraged to try to correct the interference by one or more of the following measures:

- Reorient or relocate the receiving antenna.
- Increase the separation between the equipment and receiver.
- Connect the equipment into an outlet other than the receiver's
- Consult the dealer or an experienced radio/TV technician for assistance.

#### CAUTION:

To assure continued FCC compliance:

- (1) Any changes or modifications not expressly approved by the grantee of this device could void the user's authority to operate the equipment.

#### FCC Label Compliance Statement:

This device complies with Part 15 of the FCC Rules. Operation is subject to the following two conditions: (1) this device may not cause harmful interference, and (2) this device must accept any interference received, including interference that may cause undesired operation.

#### Exposure to Radio Frequency Radiation

To comply with FCC RF exposure compliance requirements, a separation distance of at least 20cm must be maintained between the antenna of this device and all persons. This device must not be co-located or operating in conjunction with any other antenna or transmitter.