

APPLICATION FOR CERTIFICATION

On Behalf of

Futaba Corporation

Radio Control

Model No. : T3PM-2.4G

FCC ID : AZPT3PM-24G

Brand : Futaba

Prepared for : Futaba Corporation
1080 Yabutsuka Chosei-son Chosei-gun
Chiba, 299-4395 Japan.

Prepared by : Audix Technology Corporation
EMC Department
No. 53-11, Tin-Fu Tsun, Lin-Kou,
Taipei, Taiwan

Tel : (02) 2609-9301, 2609-2133

Fax: (02) 2609-9303

File Number : EM952438
Report Number : EM-F950450
Date of Test : Oct. 26 ~ 27, 2006
Date of Report : Nov. 03, 2006

TABLE OF CONTENTS

Description	Page
TEST REPORT CERTIFICATION	4
1. GENERAL INFORMATION	5
1.1. Description of Device (EUT).....	5
1.2. Tested Supporting System Details.....	6
1.3. Description of Test Facility	7
1.4. Measurement Uncertainty.....	8
2. CONDUCTED EMISSION MEASUREMENT.....	9
3. RADIATED EMISSION MEASUREMENT	10
3.1. Test Equipment.....	10
3.2. Test Setup	10
3.3. Radiated Emission Limits (§15.209)	12
3.4. Operating Condition of EUT	12
3.5. Test Procedure	12
3.6. Test Results.....	13
4. 6dB BANDWIDTH MEASUREMENT	33
4.1. Test Equipment.....	33
4.2. Block Diagram of Test Setup.....	33
4.3. Specification Limits (§15.247(a)(2))	33
4.4. Operating Condition of EUT	33
4.5. Test Procedure	33
4.6. Test Results.....	34
5. MAXIMUM PEAK OUTPUT POWER MEASUREMENT	37
5.1. Test Equipment.....	37
5.2. Block Diagram of Test Setup.....	37
5.3. Specification Limits (§15.247(b)-(3)).....	37
5.4. Operating Condition of EUT	37
5.5. Test Procedure	37
5.6. Test Results.....	38
6. EMISSION LIMITATIONS MEASUREMENT	39
6.1. Test Equipment.....	39
6.2. Block Diagram of Test Setup.....	39
6.3. Specification Limits (§15.247(c)).....	39
6.4. Operating Condition of EUT	39
6.5. Test Procedure	39
6.6. Test Results.....	40
7. BAND EDGES MEASUREMENT.....	43
7.1. Test Equipment.....	43
7.2. Block Diagram of Test Setup.....	43
7.3. Specification Limits (§15.247(c)).....	43
7.4. Operating Condition of EUT	43
7.5. Test Procedure	43
7.6. Test Results.....	43
8. POWER SPECTRAL DENSITY MEASUREMENT	45
8.1. Test Equipment.....	45
8.2. Block Diagram of Test Setup.....	45
8.3. Specification Limits (§15.247(d)).....	45
8.4. Operating Condition of EUT	45
8.5. Test Procedure	45
8.6. Test Results.....	45

9. DEVIATION TO TEST SPECIFICATIONS.....48

10.PHOTOGRAPHS49

10.1. Photos of Radiated Measurement at Semi-Anechoic Chamber 49

10.2. Photo of 6dB Bandwidth Measurement..... 55

10.3. Photo of Maximum Peak Output Measurement..... 55

10.4. Photo of Emission Limitations Measurement..... 56

10.5. Photo of Band Edges Measurement..... 56

10.6. Photo of Power Spectral Density Measurement 57

TEST REPORT CERTIFICATION

Applicant : Futaba Corporation
 Manufacturer : Futaba Corporation
 EUT Description : Radio Control
 FCC ID : AZPT3PM-24G
 (A) MODEL NO. : T3PM-2.4G
 (B) SERIAL NO. : N/A
 (C) BRAND : Futaba
 (D) POWER SUPPLY : DC 12V
 (E) TEST VOLTAGE : DC 12V (DC Power Supply)

Measurement Procedure Used:

FCC RULES AND REGULATIONS PART 15 SUBPART C, FEBRUARY 2006
AND ANSI C63.4/2003

(FCC CFR 47 Part 15C, §15.205, §15.207, §15.209 and §15.247)

The device described above was tested by AUDIX CORPORATION to determine the maximum emission levels emanating from the device. The maximum emission levels were compared to the FCC Part 15 subpart C limits.

The measurement results are contained in this test report and AUDIX CORPORATION is assumed full responsibility for the accuracy and completeness of these measurements. Also, this report shows that the EUT to be technically compliant with the FCC official limits.

This report applies to above tested sample only. This report shall not be reproduced in part without written approval of AUDIX CORPORATION.

Date of Test: Oct. 26 ~ 27, 2006

Prepared by: Tina Huang Nov. 09, 2006
(Tina Huang/Assistant)

Test Engineer: Ben Cheng Nov. 09, 2006
(Ben Cheng/Section Manager)

Approved & Authorized Signer: Leon Liu Nov. 9 2006
(Leon Liu/Senior Manager)

1. GENERAL INFORMATION

1.1. Description of Device (EUT)

Description	:	Radio Control (Transmitter Unit)
Model Number	:	T3PM-2.4G
Serial Number	:	N/A
Brand	:	Futaba
FCC ID	:	AZPT3PM-24G
Applicant	:	Futaba Corporation 1080 Yabutsuka Chosei-son Chosei-gun Chiba, 299-4395 Japan.
Manufacturer	:	Futaba Corporation 1080 Yabutsuka Chosei-son Chosei-gun Chiba, 299-4395 Japan.
Radio Technology	:	DSSS Modulation
Frequency Band	:	2405.376MHz ~ 2479.104MHz
Tested Frequency	:	2405.376MHz (Channel 02) 2442.240MHz (Channel 38) 2479.104MHz (Channel 74)
Frequency Channel	:	37 channels
Antenna (Pencil Antenna)	:	Hidaka Denki Work Antenna Gain: 1.64dBi
Receiver	:	Futaba, M/N R603FS FCC by DoC (Report Number: EM-F950143)
Date of Receipt of Sample	:	Oct. 24, 2006
Date of Test	:	Oct. 26 ~ 27, 2006

1.2. Tested Supporting System Details

1.2.1. PC SYSTEM

Model Number : VECTRA XE320
 Serial Number : SG21101966
 FCC ID : By DoC
 BSMI ID : 3912A318
 Brand : HP
 Manufacturer : First International Computer
 Power Cord : Non-Shielded, Detachable, 1.8m

1.2.2. 15" LCD MONITOR

Model Number : D5063M
 Serial Number : CN206A6034
 FCC ID : ARSLM562H
 BSMI ID : R33037
 Manufacturer : Top Victory Electronics (Fujian) Co., Ltd.
 D-Sub Cable : Shielded, Detachable, 1.8m
 Bonded two ferrite cores
 AC Adapter : Delta, M/N ADP-40TB
 BSMI ID 3892D142
 Cord: Shielded, Undetachable, 1.8m
 Bonded a ferrite core
 Power Cord : Non-Shielded, Detachable, 1.8m

1.2.3. KEYBOARD

Model Number : SDM4700P
 Serial Number : B69360HLPPD0R6
 FCC ID : By DoC
 BSMI ID : R33018
 Manufacturer : SAMSUNG (Brand: HP)
 Data Cable : Non-Shielded, Undetachable, 1.8m

1.2.4. MOUSE

Model Number : M-S69
 Serial Number : F6AB70S5BOY1NWZ
 FCC ID : JNZ211443
 BSMI ID : R41126
 Manufacturer : Logitech (Brand: HP)
 Data Cable : Non-Shielded, Undetachable, 1.8m

1.2.5. DC POWER SUPPLY #1 (To EUT Except for Conducted Test)

Model Number : 3303A
 Serial Number : 721773
 Manufacturer : TOP WARD
 DC Power Cable : Non-Shielded, Detachable, 1.2m
 AC Power Cord : Non-Shielded, Detachable, 1.8m

1.2.6. DC POWER SUPPLY #2 (To Conversion Board)

Model Number : 3303D
 Serial Number : 718859
 Manufacturer : TOP WARD
 DC Power Cable : Non-Shielded, Detachable, 0.6m
 AC Power Cord : Non-Shielded, Detachable, 1.8m

1.2.7. CONVERSION BOARD (RS-232 Level Conversion Circuit)

Part Number : 050200006
 Serial Number : N/A
 Manufacturer : FUTABA
 RS-232 Cable : Shielded, Detachable, 1.5m (To PC System)
 Data Cable : Non-Shielded, Detachable, 0.25m (To EUT)

1.2.8. BATTERY*6 (Inside EUT)-For Conducted Test

Model Number : N/A
 Serial Number : N/A
 Battery Type : AAA
 Battery Voltage : DC 1.5V

1.3. Description of Test Facility

Name of Firm : **Audix Technology Corporation**
EMC Department
 No. 53-11, Tin-Fu Tsun, Lin-Kou,
 Taipei, Taiwan

Test Location & Facility (AC) : **Semi-Anechoic Chamber**
 No. 53-11, Tin-Fu Tsun, Lin-Kou,
 Taipei, Taiwan.
 May 15, 2006 File on
 Federal Communication Commission
 Registration Number: 90993

NVLAP Lab. Code : 200077-0
 (NVLAP is a NATA accredited body under Mutual Recognition Agreement)

1.4. Measurement Uncertainty

Test Item	Frequency Range	Uncertainty (dB), (V/m)
Radiation Test (Distance: 3m)	30MHz~300MHz	± 2.91dB
	300MHz~1000MHz	± 2.74dB
	Above 1GHz	± 5.02dB

Remark : Uncertainty = $ku_c(y)$

Test Item	Uncertainty
6dB Bandwidth	± 0.05kHz
Emission Limitations	± 0.13dB
Maximum peak output power	± 0.33dBm
Band edges	± 0.13dB
Power spectral density	± 0.13dB

2. CONDUCTED EMISSION MEASUREMENT

【The EUT only employs battery power for operation, no conductive emission limits are required according to FCC Part 15 Section §15.207】

3. RADIATED EMISSION MEASUREMENT

3.1. Test Equipment

The following test equipment was used during the radiated emission measurement:

3.1.1. For Frequency Range 30MHz~1000MHz (at Semi-Anechoic Chamber)

Item	Type	Manufacturer	Model No.	Serial No.	Last Cal.	Next Cal.
1.	Spectrum Analyzer	HP	8593EM	3826A00272	Aug. 23, 06'	Aug. 23, 07'
2.	Test Receiver	R & S	ESCS30	100265	Sep. 19, 06'	Sep. 18, 07'
3.	Pre-Amplifier	HP	8447D	2944A06305	Mar. 09, 06'	Mar. 08, 07'
4.	Biconical Antenna	CHASE	VBA6106A	1264	Nov. 11, 05'	Nov. 10, 06'
5.	Log Periodic Antenna	Schwarzbeck	UHALP91 08-A	0139	Nov. 19, 05'	Nov. 18, 06'

3.1.2. For Frequency Above 1GHz (at Semi-Anechoic Chamber)

Item	Type	Manufacturer	Model No.	Serial No.	Last Cal.	Next Cal.
1.	Spectrum Analyzer	HP	8593EM	3826A00272	Aug. 23, 06'	Aug. 23, 07'
2.	Pre-Amplifier	HP	8449B	3008A01284	Jun. 30, 06'	Jun. 29, 07'
3.	3.5G High Pass Filter	HP	84300- 80038	005	Jan. 11, 06'	Jan. 10, 07'
4.	Horn Antenna	EMCO	3115	9112-3775	Jun. 01, 06'	May 31, 07'
5.	Horn Antenna	EMCO	3116	2653	Oct. 04, 06'	Oct. 03, 07'

3.2. Test Setup

3.2.1. Block Diagram of connection between EUT and simulators

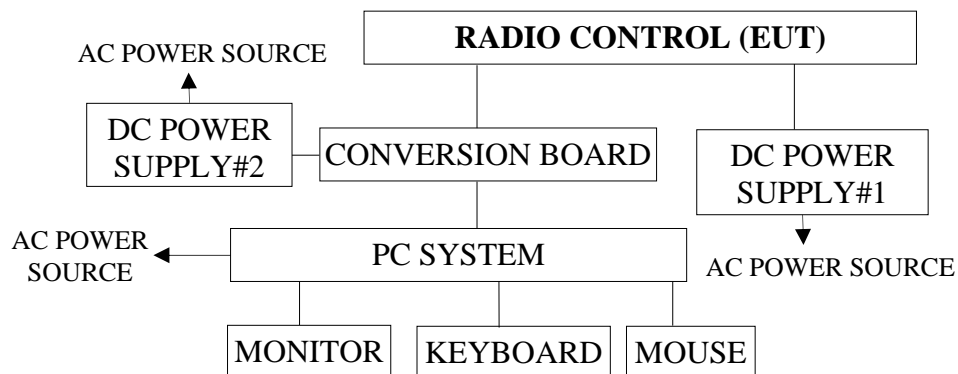

3.2.2. Semi-Anechoic Chamber (3m) Setup Diagram for 30-1000MHz

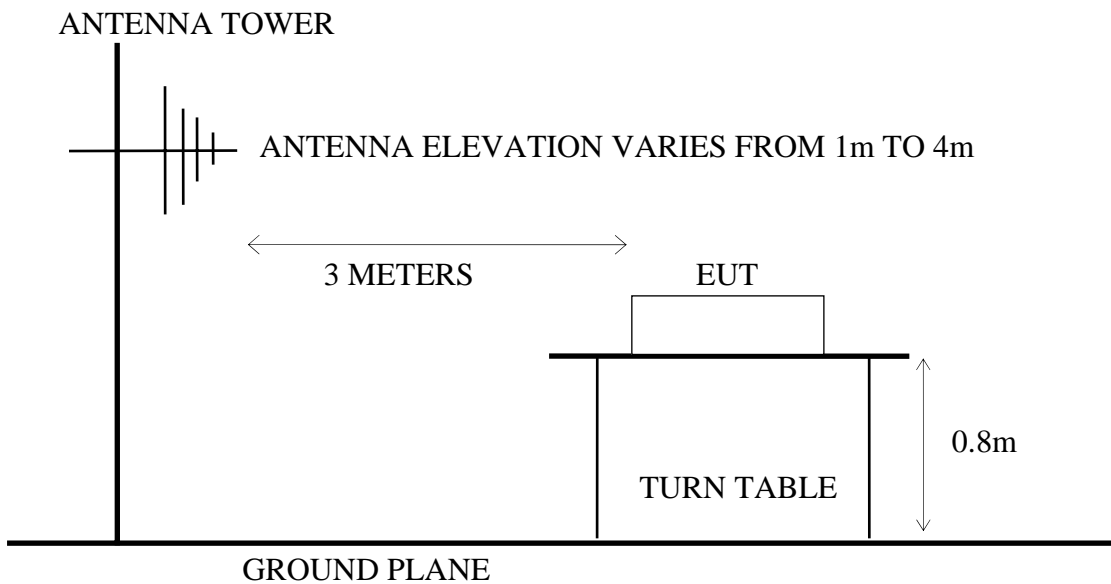

3.2.3. Semi-Anechoic Chamber (3m) Setup Diagram for above 1GHz

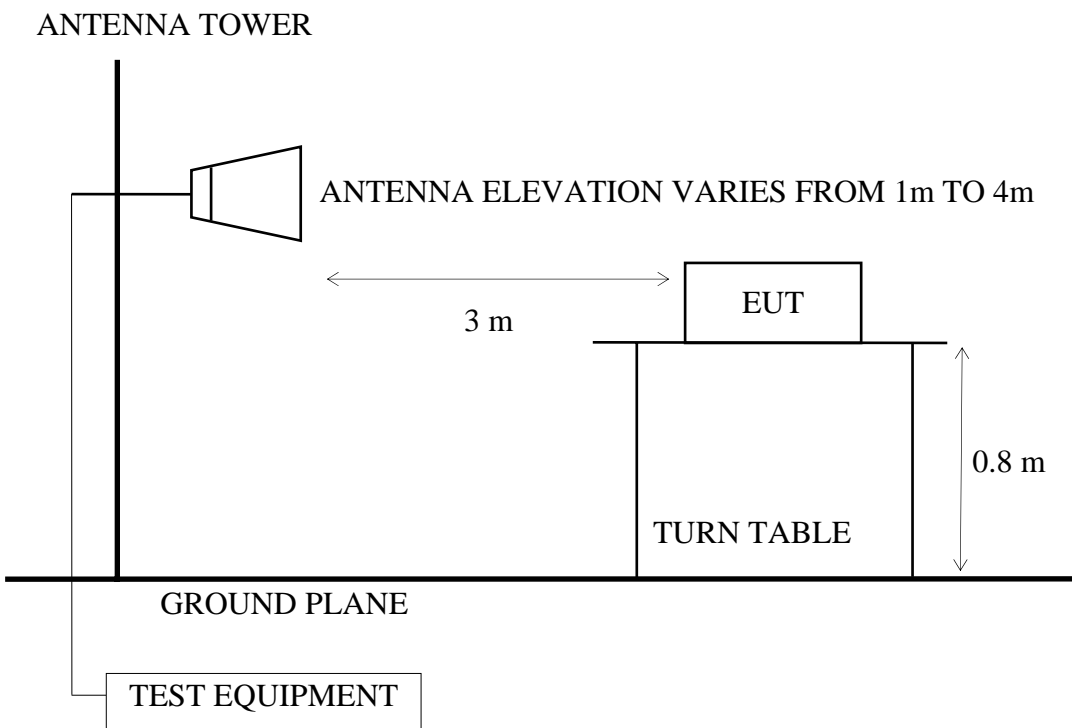

3.3. Radiated Emission Limits (§15.209)

FREQUENCY MHz	DISTANCE Meters	FIELD STRENGTHS LIMITS	
		$\mu\text{V/m}$	$\text{dB}\mu\text{V/m}$
30 ~ 88	3	100	40.0
88 ~ 216	3	150	43.5
216 ~ 960	3	200	46.0
Above 960	3	500	54.0
Above 1000	3	74.0 $\text{dB}\mu\text{V/m}$ (Peak) 54.0 $\text{dB}\mu\text{V/m}$ (Average)	

- Remark :
- (1) Emission level ($\text{dB}\mu\text{V/m}$) = 20 log Emission level ($\mu\text{V/m}$)
 - (2) The tighter limit applies at the edge between two frequency bands.
 - (3) Distance refers to the distance in meters between the measuring instrument antenna and the closed point of any part of the device or system.
 - (4) The limits in this table are based on CFR 47 Part 15.205(a)(b) and Part 15.209 (a).
 - (5) The over 1GHz limit, FCC limit is used based on CFR 47 Part 15.35 (b) and Part 15.205(b) & Part 15.209(e) and Part 15.207(c).

3.4. Operating Condition of EUT

- 3.4.1. Setup the EUT and simulator as shown on 3.2.
- 3.4.2. Turned on the power of all equipment.
- 3.4.3. The EUT was set the PC system using test program “FutabaTerm”.
- 3.4.4. The EUT was set to continuously transmit signals at 2405.376MHz (stand), 2442.240MHz (stand, side and Lie) and 2479.104MHz (stand) during testing.

3.5. Test Procedure

The EUT and its simulators were placed on a turn table which was 0.8 meter above the ground. The turn table rotated 360 degrees to determine the position of the maximum emission level. EUT was set 3 meters away from the receiving antenna which was mounted on a antenna tower. The antenna moved up and down between 1 to 4 meters to find out the maximum emission level. Broadband antenna such as calibrated biconical and log-periodical antenna or horn antenna were used as a receiving antenna. Both horizontal and vertical polarization of the antenna were set on measurement. In order to find the maximum emission, all of the interface cables were manipulated according to FCC ANSI C63.4-2003 regulation.

The bandwidth of the R&S Test Receiver ESCS30 was set at 120kHz. (For 30MHz to 1000MHz)

The resolution bandwidth and video bandwidth of test spectrum analyzer is 1MHz for peak detection (PK) at frequency above 1GHz.

The resolution bandwidth of test spectrum analyzer is 1MHz and the video bandwidth is 10Hz for average detection (AV) at frequency above 1GHz.

The frequency range from 30MHz to 25GHz (Up to 10th harmonics from fundamental frequency) was checked.

3.6. Test Results

PASSED.

(All emissions not reported below are too low against the prescribed limits.)

EUT : Radio Control M/N : T3PM-2.4G

Test Date : Oct. 26, 2006 Temperature : 25 Humidity : 64%

For Frequency Range 30MHz~1000MHz:

The EUT with following test modes were performed during this section testing and all the test results are listed in section 3.6.1.

Mode	Channel	Frequency	Position	Reference Test Data #	
				Horizontal	Vertical
1.	02	2405.376MHz	Stand	# 9	# 10
2.	38	2442.240MHz	Stand	# 10	# 9
3.			Side	# 10	# 9
4.			Lie	# 9	# 10
5.	74	2479.104MHz	Stand	# 9	# 10

* Above all final readings were measured with Quasi-Peak detector.

For Frequency above 1GHz:

The EUT with following test modes were performed during this section testing and all the test results are listed in section 3.6.2.

Mode	Channel	Frequency	Position
1.	02	2405.376MHz	Stand
2.	38	2442.240MHz	Stand
3.			Side
4.			Lie
5.	74	2479.104MHz	Stand

* Above all final readings were measured with Peak detector and Average detector.

For Restricted Bands:

The EUT was tested in restricted bands and all the test results are listed in section 3.6.3. (The restricted bands defined in part 15.205(a))

Mode	Channel	Frequency
1.	02	2405.376MHz
2.	74	2479.104MHz

3.6.1. Frequency Range 30-1000MHz



AUDIX Corp. EMC Laboratory
 No.53-11, Tin-fu Tsun, Lin-kou Hsiang, Taipei
 County, Taiwan R.O.C. Post Code:24443
 Tel:+886-2-26092133 Fax:+886-2-26099303
 Email:ttmc@ttmc.com.tw

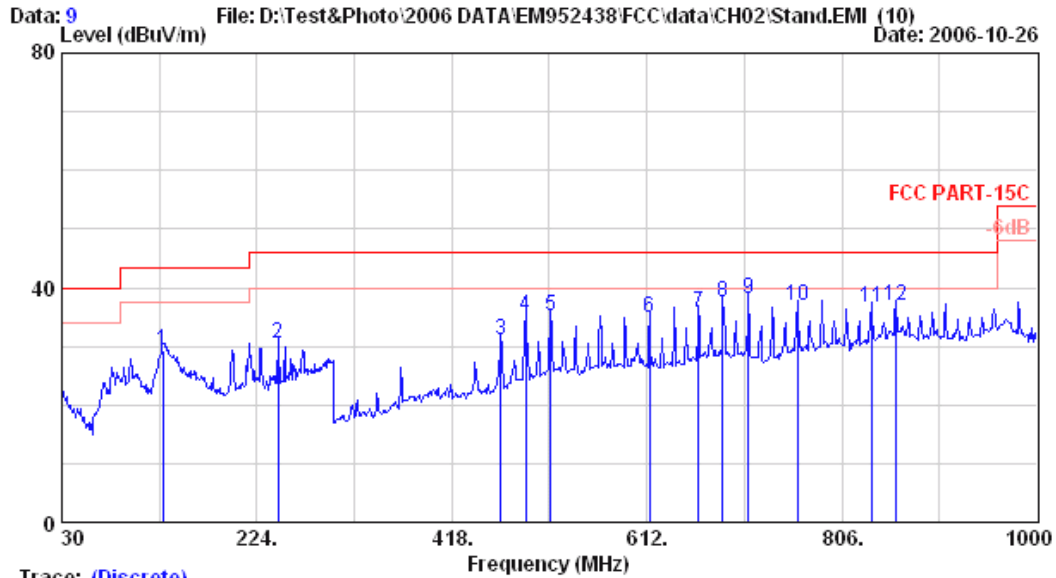

Trace: (Discrete)

Site no. : A/C Chamber Data no. : 9
 Dis. / Ant. : 3m VBA6106A/UHALP9108A Ant. pol. : HORIZONTAL
 Limit : FCC PART-15C
 Env. / Ins. : 8593EM 25°C/64% Engineer : Alvin_Yang
 EUT : Radio Control M/N:T3PM-2.4G
 Power Rating : DC12V
 Test Mode : Stand(CH02)

	Freq. (MHz)	Ant. Factor (dB/m)	Cable Loss (dB)	Reading (dBuV)	Emission Level (dBuV/m)	Limits (dBuV/m)	Margin (dB)	Remark
1	130.880	19.79	2.40	7.19	29.38	43.50	14.12	
2	245.340	23.49	3.50	3.38	30.37	46.00	15.63	
3	466.500	18.18	5.80	7.05	31.03	46.00	14.97	
4	491.720	18.61	6.33	10.16	35.10	46.00	10.90	
5	515.970	19.98	6.80	8.50	35.29	46.00	10.71	
6	614.910	21.33	6.30	7.32	34.95	46.00	11.05	
7	663.410	22.52	6.32	6.96	35.80	46.00	10.20	
8	687.660	23.26	6.50	7.74	37.49	46.00	8.51	
9	712.880	23.30	6.53	8.16	37.99	46.00	8.01	
10	761.380	23.68	6.70	6.55	36.94	46.00	9.06	
11	835.100	24.90	7.10	4.60	36.59	46.00	9.41	
12	859.350	26.01	7.20	3.67	36.87	46.00	9.13	

Remarks: 1. Emission Level= Antenna Factor + Cable Loss + Reading.
 2. The emission levels that are 20dB below the official limit are not reported.



AUDIX Corp. EMC Laboratory
 No.53-11, Tin-fu Tsun, Lin-kou Hsiang, Taipei
 County, Taiwan R.O.C. Post Code:24443
 Tel:+886-2-26092133 Fax:+886-2-26099303
 Email:ttmc@ttmc.com.tw

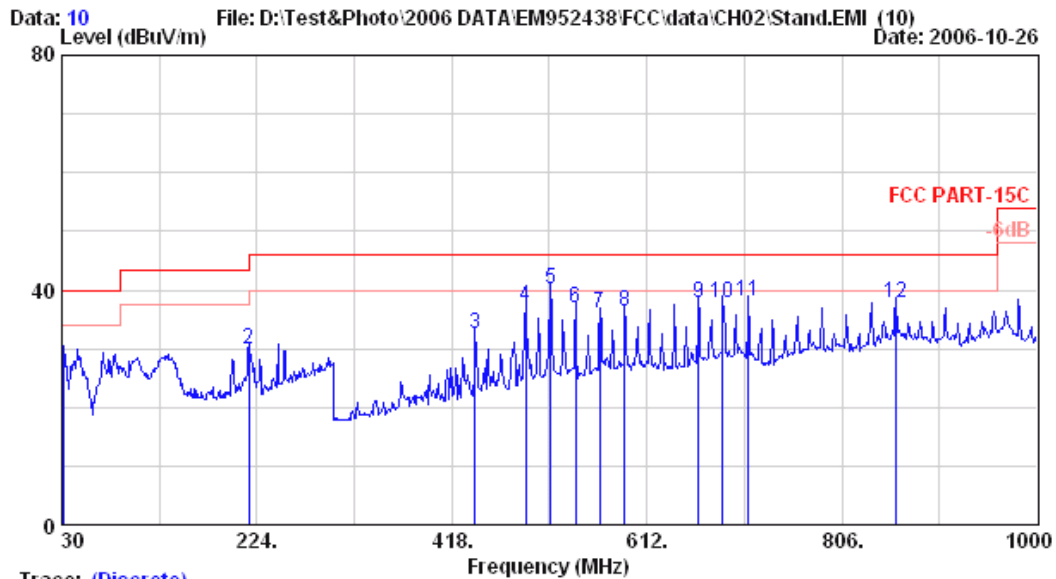

Trace: (Discrete)

Site no. : A/C Chamber Data no. : 10
 Dis. / Ant. : 3m VBA6106A/UHALP9108A Ant. pol. : VERTICAL
 Limit : FCC PART-15C
 Env. / Ins. : 8593EM 25°C/64% Engineer : Alvin_Yang
 EUT : Radio Control M/N:T3PM-2.4G
 Power Rating : DC12V
 Test Mode : Stand(CH02)

	Ant.	Cable	Emission				
Freq. (MHz)	Factor (dB/m)	Loss (dB)	Reading (dBμV)	Level (dBμV/m)	Limits (dBμV/m)	Margin (dB)	Remark
1	24.81	1.10	3.69	29.60	40.00	10.40	
2	21.86	3.20	4.92	29.99	46.00	16.01	
3	17.63	5.30	9.53	32.47	46.00	13.53	
4	18.61	6.33	12.26	37.20	46.00	8.80	
5	19.98	6.80	13.32	40.11	46.00	5.89	
6	19.25	7.01	10.55	36.81	46.00	9.19	
7	20.49	6.60	8.97	36.05	46.00	9.95	
8	21.01	6.30	9.14	36.45	46.00	9.55	
9	22.52	6.32	9.03	37.87	46.00	8.13	
10	23.26	6.50	8.08	37.84	46.00	8.16	
11	23.30	6.53	8.15	37.98	46.00	8.02	
12	26.01	7.20	4.53	37.73	46.00	8.27	

Remarks: 1. Emission Level= Antenna Factor + Cable Loss + Reading.
 2. The emission levels that are 20dB below the official limit are not reported.



AUDIX Corp. EMC Laboratory
 No.53-11, Tin-fu Tsun, Lin-kou Hsiang, Taipei
 County, Taiwan R.O.C. Post Code:24443
 Tel:+886-2-26092133 Fax:+886-2-26099303
 Email:ttmc@ttmc.com.tw

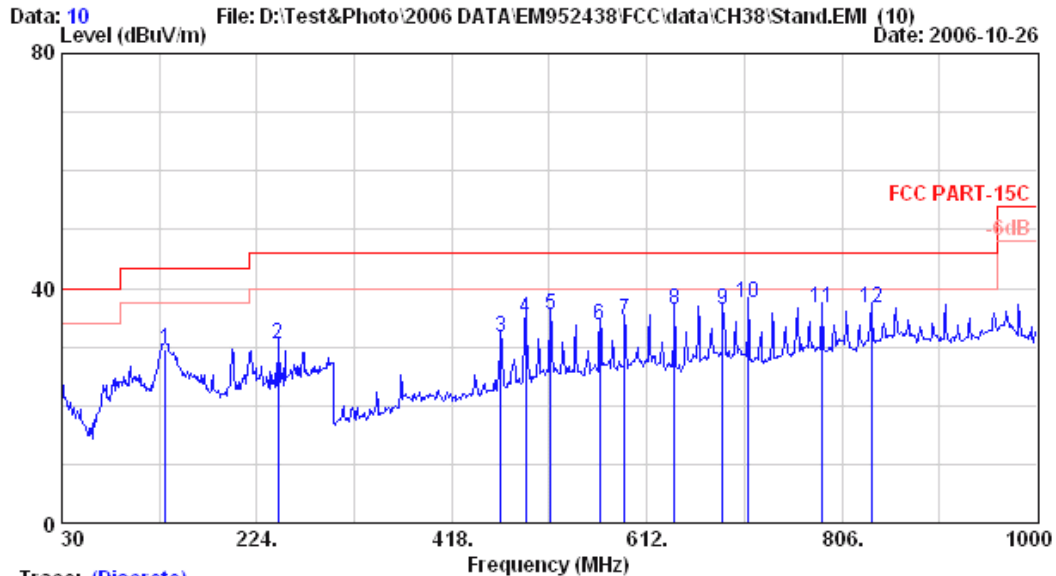

Trace: (Discrete)

Site no. : A/C Chamber Data no. : 10
 Dis. / Ant. : 3m VBA6106A/UHALP9108A Ant. pol. : HORIZONTAL
 Limit : FCC PART-15C
 Env. / Ins. : 8593EM 25°C/64% Engineer : Alvin_Yang
 EUT : Radio Control M/N:T3PM-2.4G
 Power Rating : DC12V
 Test Mode : Stand(CH38)

	Ant.	Cable	Emission		Limits	Margin	Remark
Freq. (MHz)	Factor (dB/m)	Loss (dB)	Reading (dBuV)	Level (dBuV/m)	(dBuV/m)	(dB)	
1	132.820	19.87	2.40	7.46	29.72	43.50	13.78
2	245.340	23.49	3.50	3.50	30.49	46.00	15.51
3	466.500	18.18	5.80	7.67	31.65	46.00	14.35
4	491.720	18.61	6.33	9.83	34.77	46.00	11.23
5	515.970	19.98	6.80	8.54	35.32	46.00	10.68
6	565.440	20.49	6.60	6.63	33.72	46.00	12.28
7	589.690	21.01	6.30	7.12	34.43	46.00	11.57
8	639.160	20.95	6.28	9.00	36.23	46.00	9.77
9	687.660	23.26	6.50	6.66	36.42	46.00	9.58
10	712.880	23.30	6.53	7.65	37.48	46.00	8.52
11	785.630	23.83	6.90	5.91	36.64	46.00	9.36
12	835.100	24.90	7.10	4.50	36.50	46.00	9.50

Remarks: 1. Emission Level= Antenna Factor + Cable Loss + Reading.
 2. The emission levels that are 20dB below the official limit are not reported.



AUDIX Corp. EMC Laboratory
 No.53-11, Tin-fu Tsun, Lin-kou Hsiang, Taipei
 County, Taiwan R.O.C. Post Code:24443
 Tel:+886-2-26092133 Fax:+886-2-26099303
 Email:ttenc@ttenc.com.tw

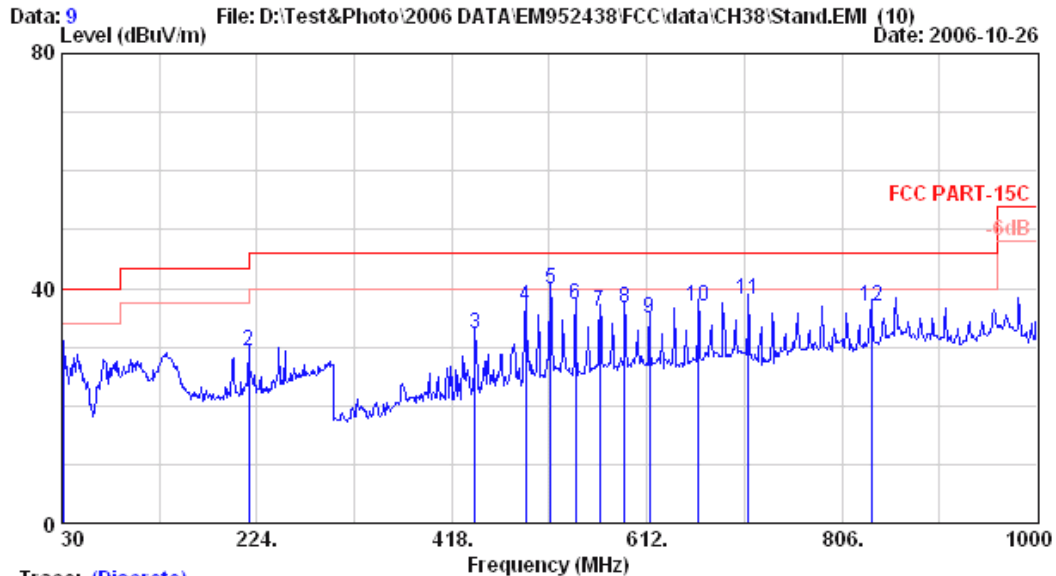

Trace: (Discrete)

Site no. : A/C Chamber Data no. : 9
 Dis. / Ant. : 3m VBA6106A/UHALP9108A Ant. pol. : VERTICAL
 Limit : FCC PART-15C
 Env. / Ins. : 8593EM 25°C/64% Engineer : Alvin_Yang
 EUT : Radio Control M/N:T3PM-2.4G
 Power Rating : DC12V
 Test Mode : Stand(CH38)

	Ant.	Cable	Emission		Limits	Margin	Remark
Freq. (MHz)	Factor (dB/m)	Loss (dB)	Reading (dBuV)	Level (dBuV/m)	(dBuV/m)	(dB)	
1	24.26	1.10	2.31	27.67	40.00	12.33	
2	21.86	3.20	4.29	29.35	46.00	16.65	
3	17.63	5.30	9.44	32.38	46.00	13.62	
4	18.61	6.33	11.90	36.84	46.00	9.16	
5	19.98	6.80	13.17	39.95	46.00	6.05	
6	19.25	7.01	10.99	37.25	46.00	8.75	
7	20.49	6.60	9.07	36.16	46.00	9.84	
8	21.01	6.30	9.29	36.61	46.00	9.39	
9	21.33	6.30	7.22	34.85	46.00	11.15	
10	22.52	6.32	8.15	36.99	46.00	9.01	
11	23.30	6.53	8.15	37.98	46.00	8.02	
12	24.90	7.10	5.05	37.05	46.00	8.95	

Remarks: 1. Emission Level= Antenna Factor + Cable Loss + Reading.
 2. The emission levels that are 20dB below the official limit are not reported.



AUDIX Corp. EMC Laboratory
 No.53-11, Tin-fu Tsun, Lin-kou Hsiang, Taipei
 County, Taiwan R.O.C. Post Code:24443
 Tel:+886-2-26092133 Fax:+886-2-26099303
 Email:ttemc@ttemc.com.tw

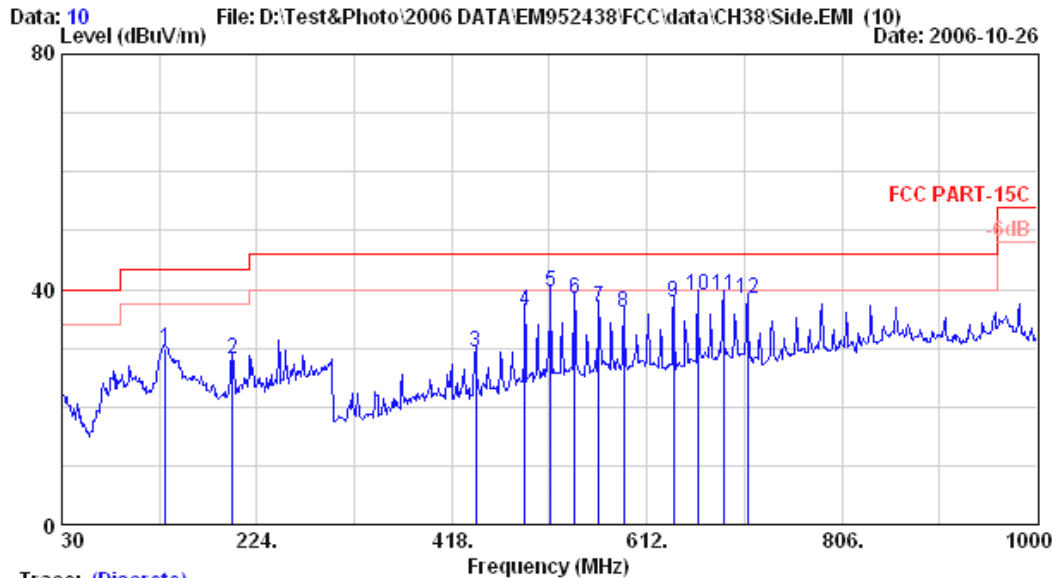

Trace: (Discrete)

Site no. : A/C Chamber Data no. : 10
 Dis. / Ant. : 3m VBA6106A/UHALP9108A Ant. pol. : HORIZONTAL
 Limit : FCC PART-15C
 Env. / Ins. : 8593EM 25°C/64% Engineer : Alvin_Yang
 EUT : Radio Control M/N:T3PM-2.4G
 Power Rating : DC12V
 Test Mode : Side(CH38)

	Ant.	Cable	Emission				
Freq. (MHz)	Factor (dB/m)	Loss (dB)	Reading (dBuV)	Level (dBuV/m)	Limits (dBuV/m)	Margin (dB)	Remark
1	19.87	2.40	7.48	29.74	43.50	13.76	
2	22.09	3.00	2.94	28.03	43.50	15.47	
3	17.62	5.30	6.32	29.24	46.00	16.76	
4	18.58	6.30	11.59	36.47	46.00	9.53	
5	19.98	6.80	12.68	39.46	46.00	6.54	
6	19.28	7.07	11.92	38.28	46.00	7.72	
7	20.42	6.60	10.01	37.03	46.00	8.97	
8	21.02	6.30	8.73	36.05	46.00	9.95	
9	20.91	6.20	10.74	37.84	46.00	8.16	
10	22.47	6.39	9.98	38.84	46.00	7.16	
11	23.26	6.50	9.23	38.99	46.00	7.01	
12	23.42	6.50	8.44	38.36	46.00	7.64	

Remarks: 1. Emission Level= Antenna Factor + Cable Loss + Reading.
 2. The emission levels that are 20dB below the official limit are not reported.



AUDIX Corp. EMC Laboratory
 No.53-11, Tin-fu Tsun, Lin-kou Hsiang, Taipei
 County, Taiwan R.O.C. Post Code:24443
 Tel:+886-2-26092133 Fax:+886-2-26099303
 Email:ttemc@ttemc.com.tw

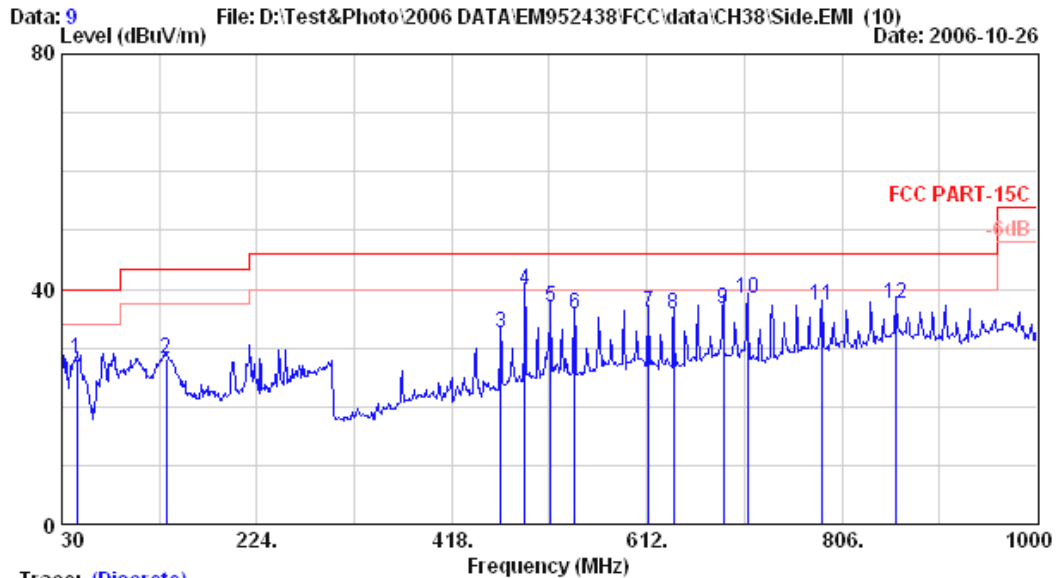

Trace: (Discrete)

Site no. : A/C Chamber Data no. : 9
 Dis. / Ant. : 3m VBA6106A/UHALP9108A Ant. pol. : VERTICAL
 Limit : FCC PART-15C
 Env. / Ins. : 8593EM 25°C/64% Engineer : Alvin_Yang
 EUT : Radio Control M/N:T3PM-2.4G
 Power Rating : DC12V
 Test Mode : Side(CH38)

	Ant.	Cable	Emission				
Freq. (MHz)	Factor (dB/m)	Loss (dB)	Reading (dBuV)	Level (dBuV/m)	Limits (dBuV/m)	Margin (dB)	Remark
1	44.580	19.10	7.71	28.17	40.00	11.83	
2	134.004	19.89	5.93	28.22	43.50	15.28	
3	466.428	18.18	8.49	32.47	46.00	13.53	
4	490.728	18.58	15.00	39.88	46.00	6.12	
5	516.000	19.98	10.09	36.87	46.00	9.13	
6	540.300	19.28	9.46	35.81	46.00	10.19	
7	614.172	21.34	8.52	36.16	46.00	9.84	
8	638.472	20.91	8.72	35.83	46.00	10.17	
9	688.044	23.26	6.90	36.66	46.00	9.34	
10	712.344	23.42	8.48	38.40	46.00	7.60	
11	786.216	23.79	6.42	37.11	46.00	8.89	
12	860.088	26.03	4.35	37.59	46.00	8.41	

Remarks: 1. Emission Level= Antenna Factor + Cable Loss + Reading.
 2. The emission levels that are 20dB below the official limit are not reported.



AUDIX Corp. EMC Laboratory
 No.53-11, Tin-fu Tsun, Lin-kou Hsiang, Taipei
 County, Taiwan R.O.C. Post Code:24443
 Tel:+886-2-26092133 Fax:+886-2-26099303
 Email:ttmc@ttmc.com.tw

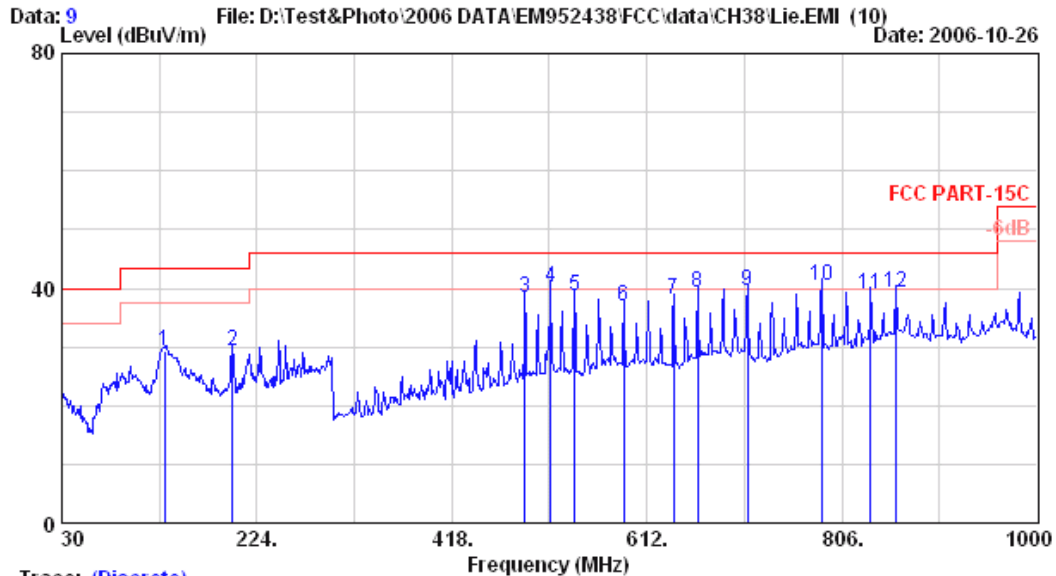

Trace: (Discrete)

Site no. : A/C Chamber Data no. : 9
 Dis. / Ant. : 3m VBA6106A/UHALP9108A Ant. pol. : HORIZONTAL
 Limit : FCC PART-15C
 Env. / Ins. : 8593EM 25°C/64% Engineer : Alvin_Yang
 EUT : Radio Control M/N:T3PM-2.4G
 Power Rating : DC12V
 Test Mode : Lie(CH38)

	Ant.	Cable	Emission		Limits	Margin	Remark
Freq. (MHz)	Factor (dB/m)	Loss (dB)	Reading (dBuV)	Level (dBuV/m)	(dBuV/m)	(dB)	
1	19.83	2.40	7.00	29.23	43.50	14.27	
2	22.09	3.00	4.32	29.41	43.50	14.09	
3	18.58	6.30	13.57	38.45	46.00	7.55	
4	19.98	6.80	13.44	40.23	46.00	5.77	
5	19.28	7.07	12.34	38.69	46.00	7.31	
6	21.02	6.30	9.49	36.81	46.00	9.19	
7	20.91	6.20	10.97	38.08	46.00	7.92	
8	22.47	6.39	10.28	39.14	46.00	6.86	
9	23.42	6.50	9.61	39.53	46.00	6.47	
10	23.79	6.90	9.78	40.47	46.00	5.53	
11	24.90	7.10	7.12	39.12	46.00	6.88	
12	26.03	7.20	6.12	39.35	46.00	6.65	

Remarks: 1. Emission Level= Antenna Factor + Cable Loss + Reading.
 2. The emission levels that are 20dB below the official limit are not reported.



AUDIX Corp. EMC Laboratory
 No.53-11, Tin-fu Tsun, Lin-kou Hsiang, Taipei
 County, Taiwan R.O.C. Post Code:24443
 Tel:+886-2-26092133 Fax:+886-2-26099303
 Email:ttmc@ttmc.com.tw

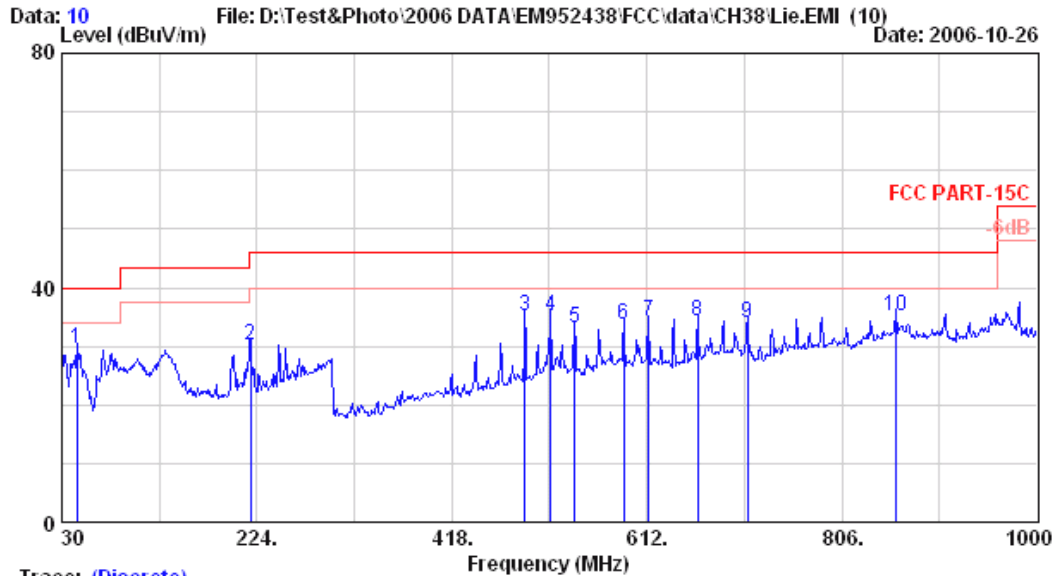

Trace: (Discrete)

Site no. : A/C Chamber Data no. : 10
 Dis. / Ant. : 3m VBA6106A/UHALP9108A Ant. pol. : VERTICAL
 Limit : FCC PART-15C
 Env. / Ins. : 8593EM 25°C/64% Engineer : Alvin_Yang
 EUT : Radio Control M/N:T3PM-2.4G
 Power Rating : DC12V
 Test Mode : Lie(CH38)

	Freq.	Ant.	Cable	Emission			Margin	Remark
	(MHz)	Factor	Loss	Reading	Level	Limits	(dB)	
		(dB/m)	(dB)	(dBuV)	(dBuV/m)	(dBuV/m)		
1	44.580	19.10	1.36	9.03	29.49	40.00	10.51	
2	217.596	21.90	3.20	5.23	30.33	46.00	15.67	
3	490.728	18.58	6.30	10.37	35.24	46.00	10.76	
4	516.000	19.98	6.80	8.50	35.28	46.00	10.72	
5	540.300	19.28	7.07	6.72	33.07	46.00	12.93	
6	588.900	21.02	6.30	6.25	33.57	46.00	12.43	
7	614.172	21.34	6.30	6.55	34.19	46.00	11.81	
8	662.772	22.47	6.39	5.32	34.19	46.00	11.81	
9	712.344	23.42	6.50	3.98	33.89	46.00	12.11	
10	860.088	26.03	7.20	2.00	35.23	46.00	10.77	

Remarks: 1. Emission Level= Antenna Factor + Cable Loss + Reading.
 2. The emission levels that are 20dB below the official limit are not reported.



AUDIX Corp. EMC Laboratory
 No.53-11, Tin-fu Tsun, Lin-kou Hsiang, Taipei
 County, Taiwan R.O.C. Post Code:24443
 Tel:+886-2-26092133 Fax:+886-2-26099303
 Email:ttmc@ttmc.com.tw

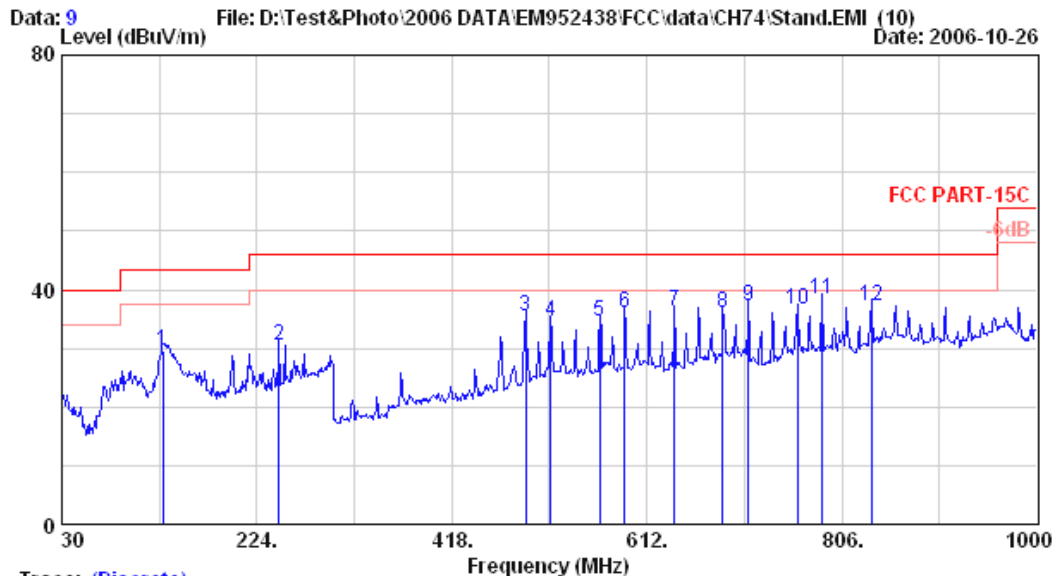

Trace: (Discrete)

Site no. : A/C Chamber Data no. : 9
 Dis. / Ant. : 3m VBA6106A/UHALP9108A Ant. pol. : HORIZONTAL
 Limit : FCC PART-15C
 Env. / Ins. : 8593EM 25°C/64% Engineer : Alvin_Yang
 EUT : Radio Control M/N:T3PM-2.4G
 Power Rating : DC12V
 Test Mode : Stand(CH74)

	Ant.	Cable	Emission		Limits	Margin	Remark
Freq. (MHz)	Factor (dB/m)	Loss (dB)	Reading (dBμV)	Level (dBμV/m)	(dBμV/m)	(dB)	
1	130.880	19.79	2.40	7.54	29.73	43.50	13.77
2	246.310	23.54	3.50	3.46	30.50	46.00	15.50
3	491.720	18.61	6.33	10.50	35.45	46.00	10.55
4	515.970	19.98	6.80	7.79	34.57	46.00	11.43
5	565.440	20.49	6.60	7.56	34.65	46.00	11.35
6	589.690	21.01	6.30	8.75	36.06	46.00	9.94
7	639.160	20.95	6.28	9.00	36.23	46.00	9.77
8	687.660	23.26	6.50	6.36	36.12	46.00	9.88
9	712.880	23.30	6.53	7.43	37.26	46.00	8.74
10	761.380	23.68	6.70	6.26	36.65	46.00	9.35
11	785.630	23.83	6.90	7.55	38.28	46.00	7.72
12	835.100	24.90	7.10	5.36	37.36	46.00	8.64

Remarks: 1. Emission Level= Antenna Factor + Cable Loss + Reading.
 2. The emission levels that are 20dB below the official limit are not reported.



AUDIX Corp. EMC Laboratory
 No.53-11, Tin-fu Tsun, Lin-kou Hsiang, Taipei
 County, Taiwan R.O.C. Post Code:24443
 Tel:+886-2-26092133 Fax:+886-2-26099303
 Email:ttmc@ttmc.com.tw

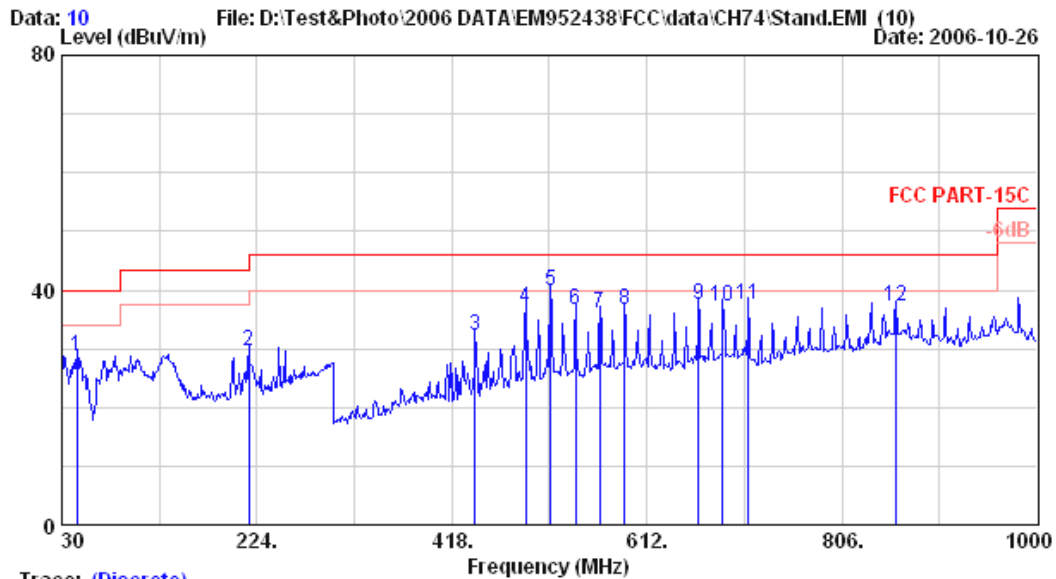

Trace: (Discrete)

Site no.	: A/C Chamber	Data no.	: 10
Dis. / Ant.	: 3m VBA6106A/UHALP9108A	Ant. pol.	: VERTICAL
Limit	: FCC PART-15C		
Env. / Ins.	: 8593EM 25°C/64%	Engineer	: Alvin_Yang
EUT	: Radio Control M/N:T3PM-2.4G		
Power Rating	: DC12V		
Test Mode	: Stand(CH74)		

	Ant.	Cable	Emission		Limits	Margin	Remark
Freq. (MHz)	Factor (dB/m)	Loss (dB)	Reading (dBµV)	Level (dBµV/m)	(dBµV/m)	(dB)	
1	44.550	19.10	1.36	8.40	28.86	40.00	11.14
2	216.240	21.86	3.20	4.50	29.56	46.00	16.44
3	441.280	17.63	5.30	9.34	32.28	46.00	13.72
4	491.720	18.61	6.33	11.84	36.79	46.00	9.21
5	515.970	19.98	6.80	13.16	39.95	46.00	6.05
6	541.190	19.25	7.01	10.45	36.71	46.00	9.29
7	565.440	20.49	6.60	9.09	36.17	46.00	9.83
8	589.690	21.01	6.30	9.46	36.77	46.00	9.23
9	663.410	22.52	6.32	8.69	37.53	46.00	8.47
10	687.660	23.26	6.50	7.53	37.29	46.00	8.71
11	712.880	23.30	6.53	7.80	37.63	46.00	8.37
12	859.350	26.01	7.20	3.91	37.11	46.00	8.89

Remarks: 1. Emission Level= Antenna Factor + Cable Loss + Reading.
 2. The emission levels that are 20dB below the official limit are not reported.

3.6.2. Above 1GHz Frequency Range Measurement Results

Date of Test : Oct. 26, 2006 Temperature : 25

EUT : Radio Control Humidity : 64%

Test Mode : Channel: 02 (Frequency: 2405.376MHz), Position: Stand

	Emission Frequency MHz	Antenna Factor dB/m	Cable Loss dB	Meter Reading Horizontal dBμV	Emission Level Horizontal dBμV/m	Limits dBμV/m	Margin dB
Peak	1465.360	25.39	5.33	14.36	45.08	74.00	28.92
	1603.120	25.95	6.18	15.04	47.17	74.00	26.83
Average	1465.360	25.39	5.33	5.36	36.08	54.00	17.92
	1603.120	25.95	6.18	6.04	38.17	54.00	15.83

	Emission Frequency MHz	Antenna Factor dB/m	Cable Loss dB	Meter Reading Vertical dBμV	Emission Level Vertical dBμV/m	Limits dBμV/m	Margin dB
Peak	1465.360	25.39	5.33	13.31	44.03	74.00	29.97
	1603.120	25.95	6.18	16.23	48.36	74.00	25.64
Average	1465.360	25.39	5.33	4.31	35.03	54.00	18.97
	1603.120	25.95	6.18	7.23	39.36	54.00	14.64

Remark : 1. Emission Level = Antenna Factor + Cable Loss + Meter Reading.
 2. Measurement was up to 25GHz, but the emissions level were too low against the official limit and not report.

Date of Test : Oct. 26, 2006 Temperature : 25

EUT : Radio Control Humidity : 64%

Test Mode : Channel: 38 (Frequency: 2442.240MHz), Position: Stand

	Emission Frequency MHz	Antenna Factor dB/m	Cable Loss dB	Meter Reading Horizontal dBµV	Emission Level Horizontal dBµV/m	Limits dBµV/m	Margin dB
Peak	1460.320	25.39	5.31	13.01	43.71	74.00	30.29
	1729.120	26.58	7.04	12.66	46.28	74.00	27.72
Average	1460.320	25.39	5.31	4.01	34.71	54.00	19.29
	1729.120	26.58	7.04	3.66	37.28	54.00	16.72

	Emission Frequency MHz	Antenna Factor dB/m	Cable Loss dB	Meter Reading Vertical dBµV	Emission Level Vertical dBµV/m	Limits dBµV/m	Margin dB
Peak	1465.360	25.39	5.33	13.78	44.50	74.00	29.50
	1703.920	26.46	6.85	12.31	45.62	74.00	28.38
Average	1465.360	25.39	5.33	4.78	35.50	54.00	18.50
	1703.920	26.46	6.85	3.31	36.62	54.00	17.38

Remark : 1. Emission Level = Antenna Factor + Cable Loss + Meter Reading.
 2. Measurement was up to 25GHz, but the emissions level were too low against the official limit and not report.

Date of Test : Oct. 26, 2006 Temperature : 25

EUT : Radio Control Humidity : 64%

Test Mode : Channel: 38 (Frequency: 2442.240MHz), Position: Side

	Emission Frequency MHz	Antenna Factor dB/m	Cable Loss dB	Meter Reading Horizontal dBμV	Emission Level Horizontal dBμV/m	Limits dBμV/m	Margin dB
Peak	1703.920	26.46	6.85	17.34	50.65	74.00	23.35
	2065.120	27.94	5.94	13.50	47.38	74.00	26.62
Average	1703.920	26.46	6.85	7.34	40.65	54.00	13.35
	2065.120	27.94	5.94	3.50	37.38	54.00	16.62

	Emission Frequency MHz	Antenna Factor dB/m	Cable Loss dB	Meter Reading Vertical dBμV	Emission Level Vertical dBμV/m	Limits dBμV/m	Margin dB
Peak	1330.960	25.34	4.93	12.90	43.17	74.00	30.83
	1880.320	27.27	6.48	12.92	46.67	74.00	27.33
Average	1330.960	25.34	4.93	3.90	34.17	54.00	19.83
	1880.320	27.27	6.48	3.92	37.67	54.00	16.33

Remark : 1. Emission Level = Antenna Factor + Cable Loss + Meter Reading.
 2. Measurement was up to 25GHz, but the emissions level were too low against the official limit and not report.

Date of Test : Oct. 26, 2006 Temperature : 25

EUT : Radio Control Humidity : 64%

Test Mode : Channel: 38 (Frequency: 2442.240MHz), Position: Lie

	Emission Frequency MHz	Antenna Factor dB/m	Cable Loss dB	Meter Reading Horizontal dBµV	Emission Level Horizontal dBµV/m	Limits dBµV/m	Margin dB
Peak	1468.720	25.39	5.33	12.80	43.52	74.00	30.48
	1795.960	26.89	6.94	12.66	46.49	74.00	27.51
Average	1468.720	25.39	5.33	4.80	35.52	54.00	18.48
	1792.960	26.89	6.94	4.66	38.49	54.00	15.51

	Emission Frequency MHz	Antenna Factor dB/m	Cable Loss dB	Meter Reading Vertical dBµV	Emission Level Vertical dBµV/m	Limits dBµV/m	Margin dB
Peak	1460.320	25.39	5.31	13.78	44.48	74.00	29.52
	1787.920	26.86	6.97	13.04	46.87	74.00	27.13
Average	1460.320	25.39	5.31	5.78	36.48	54.00	17.52
	1787.920	26.86	6.97	4.04	37.87	54.00	16.13

Remark : 1. Emission Level = Antenna Factor + Cable Loss + Meter Reading.
 2. Measurement was up to 25GHz, but the emissions level were too low against the official limit and not report.

Date of Test : Oct. 26, 2006 Temperature : 25

EUT : Radio Control Humidity : 64%

Test Mode : Channel: 74 (Frequency: 2479.104MHz), Position: Stand

	Emission Frequency MHz	Antenna Factor dB/m	Cable Loss dB	Meter Reading Horizontal dBµV	Emission Level Horizontal dBµV/m	Limits dBµV/m	Margin dB
Peak	1456.960	25.39	5.31	13.14	43.84	74.00	30.16
	1653.520	26.22	6.52	13.48	46.22	74.00	27.78
Average	1456.960	25.39	5.31	3.14	33.84	54.00	20.16
	1653.520	26.22	6.52	3.48	36.22	54.00	17.78

	Emission Frequency MHz	Antenna Factor dB/m	Cable Loss dB	Meter Reading Vertical dBµV	Emission Level Vertical dBµV/m	Limits dBµV/m	Margin dB
Peak	1460.320	25.39	5.31	13.26	43.96	74.00	30.04
	1759.360	26.72	7.12	19.85	53.69	74.00	20.31
Average	1460.320	25.39	5.31	4.26	34.96	54.00	19.04
	1759.360	26.72	7.12	9.85	43.69	54.00	10.31

Remark : 1. Emission Level = Antenna Factor + Cable Loss + Meter Reading.
 2. Measurement was up to 25GHz, but the emissions level were too low against the official limit and not report.

3.6.3. Restricted Bands Measurement Results

Date of Test : Oct. 26, 2006 Temperature : 25

EUT : Radio Control Humidity : 64%

Test Mode : Channel: 02, Frequency: 2405.376MHz

	Emission Frequency MHz	Antenna Factor dB/m	Cable Loss dB	Meter Reading Horizontal dBμV	Emission Level Horizontal dBμV/m	Limits dBμV/m	Margin dB
Peak *	2386.890	28.59	6.33	8.21	43.13	74.00	30.87
Average *	2386.670	28.59	6.33	-3.88	31.04	54.00	22.96

- Remark : 1. Emission Level = Antenna Factor + Cable Loss + Meter Reading.
 2. Low frequency section (spurious in the restricted band 2310-2390MHz).
 3. '*' The field strength of emission appearing within Part 15.205(a) shall not exceed the limits shown in section 15.209.



AUDIX Corp. EMC Laboratory
 No.53-11, Tin-Fu Tsun, Lin-Kou Hsiang, Taipei
 County, Taiwan R.O.C. Post Code 24443
 Tel:+886-2-26092133 Fax:+886-2-26099303
 Email:ttmc@ttmc.com.tw



AUDIX Corp. EMC Laboratory
 No.53-11, Tin-Fu Tsun, Lin-Kou Hsiang, Taipei
 County, Taiwan R.O.C. Post Code 24443
 Tel:+886-2-26092133 Fax:+886-2-26099303
 Email:ttmc@ttmc.com.tw

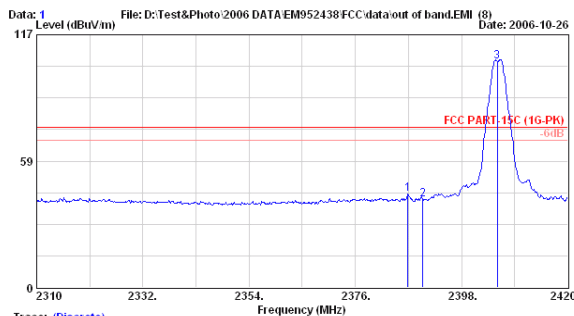

Site no. : A/C Chamber Data no. : 1
 Dis. / Ant. : 3m 3115 Ant. pol. : HORIZONTAL
 Limit : FCC PART-15C (1G-PK)
 Env. / Ins. : 8593EM 25°C/64% Engineer : Alvin_Yang
 EUT : Radio Control M/N:T3PM-2.4G
 Power Rating : DC 12V
 Test Mode : Stand (CH02)

	Freq. (MHz)	Ant. Factor (dB/m)	Cable Loss (dB)	Reading (dBμV)	Emission Level (dBμV/m)	Limits (dBμV/m)	Margin (dB)	Remark
1	2386.890	28.59	6.33	8.21	43.14	74.00	30.86	Peak
2	2390.000	28.59	6.34	5.69	40.63	74.00	33.37	Peak
3	2405.376	28.63	6.36	69.59	104.58	74.00	-30.58	Peak

Remarks: 1. Emission Level= Antenna Factor + Cable Loss + Reading.
 2. The emission levels that are 20dB below the official limit are not reported.

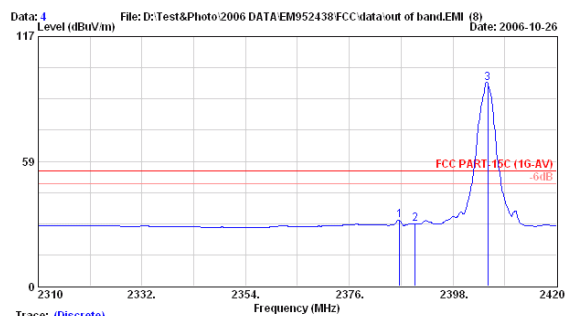

Site no. : A/C Chamber Data no. : 4
 Dis. / Ant. : 3m 3115 Ant. pol. : HORIZONTAL
 Limit : FCC PART-15C (1G-AV)
 Env. / Ins. : 8593EM 25°C/64% Engineer : Alvin_Yang
 EUT : Radio Control M/N:T3PM-2.4G
 Power Rating : DC 12V
 Test Mode : Stand (CH02)

	Freq. (MHz)	Ant. Factor (dB/m)	Cable Loss (dB)	Reading (dBμV)	Emission Level (dBμV/m)	Limits (dBμV/m)	Margin (dB)	Remark
1	2386.670	28.59	6.33	-3.88	31.05	54.00	22.95	Average
2	2390.000	28.59	6.34	-5.79	29.15	54.00	24.85	Average
3	2405.376	28.63	6.36	60.36	95.35	54.00	-41.35	Average

Remarks: 1. Emission Level= Antenna Factor + Cable Loss + Reading.
 2. The emission levels that are 20dB below the official limit are not reported.

Date of Test : Oct. 26, 2006 Temperature : 25

EUT : Radio Control Humidity : 64%

Test Mode : Channel: 02, Frequency: 2405.376MHz

	Emission Frequency MHz	Antenna Factor dB/m	Cable Loss dB	Meter Reading Vertical dBμV	Emission Level Vertical dBμV/m	Limits dBμV/m	Margin dB
Peak *	2386.670	28.59	6.33	13.08	48.00	74.00	26.00
Average *	2386.670	28.59	6.33	4.02	38.94	54.00	15.06

- Remark : 1. Emission Level = Antenna Factor + Cable Loss + Meter Reading.
 2. Low frequency section (spurious in the restricted band 2310-2390MHz).
 3. '*' The field strength of emission appearing within Part 15.205(a) shall not exceed the limits shown in section 15.209.



AUDIX Corp. EMC Laboratory
 No.53-11, Tin-Fu Tsun, Lin-Kou Hsiang, Taipei
 County, Taiwan R.O.C. Post Code 24443
 Tel:+886-2-26092133 Fax:+886-2-26099303
 Email:ttmc@ttmc.com.tw

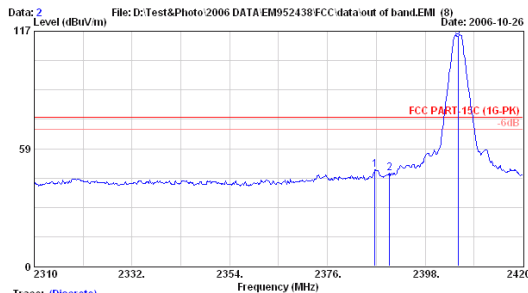

Trace: (Discrete)
 Site no. : A/C Chamber Data no. : 2
 Dis. / Ant. : 3m 3115 Ant. pol. : VERTICAL
 Limit : FCC PART-15C (1G-PK)
 Env. / Ins. : 8593EM 25°C/64% Engineer : Alvin_Yang
 EUT : Radio Control M/N:T3PM-2.4G
 Power Rating : DC 12V
 Test Mode : Stand (CH02)

Freq. (MHz)	Ant. Factor (dB/m)	Cable Loss (dB)	Reading (dBμV)	Emission Level (dBμV/m)	Limits (dBμV/m)	Margin (dB)	Remark
1 2386.670	28.59	6.33	13.08	48.01	74.00	25.99	Peak
2 2390.000	28.59	6.34	11.56	46.50	74.00	27.50	Peak
3 2405.376	28.63	6.36	79.06	114.05	74.00	-40.05	Peak

Remarks: 1. Emission Level= Antenna Factor + Cable Loss + Reading.
 2. The emission levels that are 20dB below the official limit are not reported.



AUDIX Corp. EMC Laboratory
 No.53-11, Tin-Fu Tsun, Lin-Kou Hsiang, Taipei
 County, Taiwan R.O.C. Post Code 24443
 Tel:+886-2-26092133 Fax:+886-2-26099303
 Email:ttmc@ttmc.com.tw

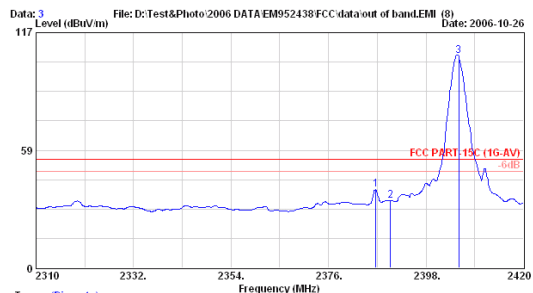

Trace: (Discrete)
 Site no. : A/C Chamber Data no. : 3
 Dis. / Ant. : 3m 3115 Ant. pol. : VERTICAL
 Limit : FCC PART-15C (1G-AV)
 Env. / Ins. : 8593EM 25°C/64% Engineer : Alvin_Yang
 EUT : Radio Control M/N:T3PM-2.4G
 Power Rating : DC 12V
 Test Mode : Stand (CH02)

Freq. (MHz)	Ant. Factor (dB/m)	Cable Loss (dB)	Reading (dBμV)	Emission Level (dBμV/m)	Limits (dBμV/m)	Margin (dB)	Remark
1 2386.670	28.59	6.33	4.02	38.95	54.00	15.05	Average
2 2390.000	28.59	6.34	-1.47	33.47	54.00	20.53	Average
3 2405.376	28.63	6.36	70.51	105.50	54.00	-51.50	Average

Remarks: 1. Emission Level= Antenna Factor + Cable Loss + Reading.
 2. The emission levels that are 20dB below the official limit are not reported.

Date of Test : Oct. 26, 2006 Temperature : 25

EUT : Radio Control Humidity : 64%

Test Mode : Channel: 74, Frequency: 2479.104MHz

	Emission Frequency MHz	Antenna Factor dB/m	Cable Loss dB	Meter Reading Horizontal dBμV	Emission Level Horizontal dBμV/m	Limits dBμV/m	Margin dB
Peak *	2485.200	28.77	6.45	17.19	52.41	74.00	21.59
Average *	2485.200	28.77	6.45	7.03	42.25	54.00	11.75

- Remark : 1. Emission Level = Antenna Factor + Cable Loss + Meter Reading.
 2. High frequency section (spurious in the restricted band 2483.5-2500MHz).
 3. '*' The field strength of emission appearing within Part 15.205(a) shall not exceed the limits shown in section 15.209.



AUDIX Corp. EMC Laboratory
 No.53-11, Tin-Fu Tsun, Lin-kou Hsiang, Tain County, Taiwan R.O.C. Post Code:24443
 Tel:+886-2-26092133 Fax:+886-2-26099303
 Email:temc@ttemc.com.tw



AUDIX Corp. EMC Laboratory
 No.53-11, Tin-Fu Tsun, Lin-kou Hsiang, Taipei County, Taiwan R.O.C. Post Code:24443
 Tel:+886-2-26092133 Fax:+886-2-26099303
 Email:temc@ttemc.com.tw

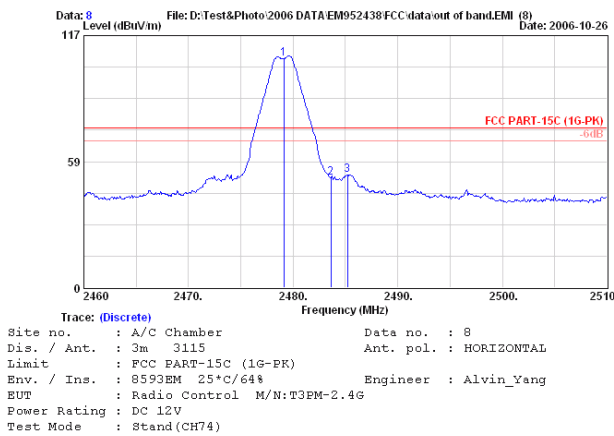

	Freq. (MHz)	Ant. Factor (dB/m)	Cable Loss (dB)	Reading (dBμV)	Emission Level (dBμV/m)	Limits (dBμV/m)	Margin (dB)	Remark
1	2479.104	28.76	6.44	71.19	106.39	74.00	-32.39	Peak
2	2483.600	28.77	6.45	15.90	51.12	74.00	22.88	Peak
3	2485.200	28.77	6.45	17.19	52.42	74.00	21.58	Peak

- Remarks: 1. Emission Level= Antenna Factor + Cable Loss + Reading.
 2. The emission levels that are 20dB below the official limit are not reported.

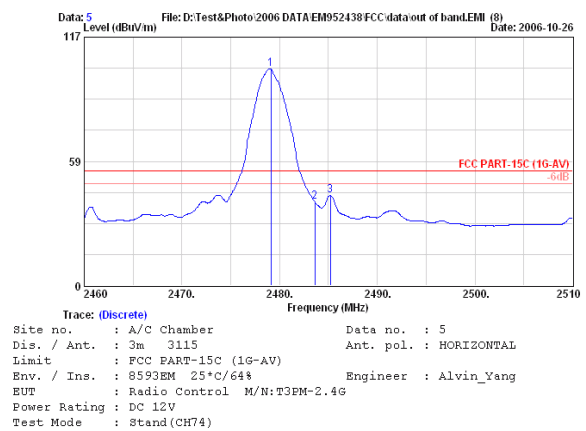

	Freq. (MHz)	Ant. Factor (dB/m)	Cable Loss (dB)	Reading (dBμV)	Emission Level (dBμV/m)	Limits (dBμV/m)	Margin (dB)	Remark
1	2479.104	28.76	6.44	66.77	101.97	54.00	-47.97	Average
2	2483.600	28.77	6.45	4.31	39.53	54.00	14.47	Average
3	2485.200	28.77	6.45	7.03	42.26	54.00	11.74	Average

- Remarks: 1. Emission Level= Antenna Factor + Cable Loss + Reading.
 2. The emission levels that are 20dB below the official limit are not reported.

Date of Test : Oct. 26, 2006 Temperature : 25

EUT : Radio Control Humidity : 64%

Test Mode : Channel: 74, Frequency: 2479.104MHz

	Emission Frequency MHz	Antenna Factor dB/m	Cable Loss dB	Meter Reading Vertical dBμV	Emission Level Vertical dBμV/m	Limits dBμV/m	Margin dB
Peak *	2485.200	28.77	6.45	24.56	59.78	74.00	14.22
Average *	2485.200	28.77	6.45	15.85	51.07	54.00	2.93

- Remark : 1. Emission Level = Antenna Factor + Cable Loss + Meter Reading.
 2. High frequency section (spurious in the restricted band 2483.5-2500MHz).
 3. '*' The field strength of emission appearing within Part 15.205(a) shall not exceed the limits shown in section 15.209.



AUDIX Corp. EMC Laboratory
 No.53-11, Tin-fu Tsun, Lin-kou Hsiang, Taipei
 County, Taiwan R.O.C. Post Code:24443
 Tel:+886-2-26092133 Fax:+886-2-26099303
 Email:ttenc@ttenc.com.tw



AUDIX Corp. EMC Laboratory
 No.53-11, Tin-fu Tsun, Lin-kou Hsiang, Taipei
 County, Taiwan R.O.C. Post Code:24443
 Tel:+886-2-26092133 Fax:+886-2-26099303
 Email:ttenc@ttenc.com.tw

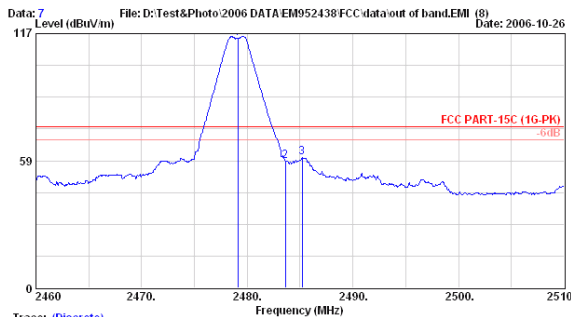

Trace: (Discrete)
 Site no. : A/C Chamber Data no. : 7
 Dis. / Ant. : 3m 3115 Ant. pol. : VERTICAL
 Limit : FCC PART-15C (1G-PK)
 Env. / Ins. : 8593EM 25°C/64% Engineer : Alvin_Yang
 EUT : Radio Control M/N:T3PM-2.4G
 Power Rating : DC 12V
 Test Mode : Stand(CH74)

Trace	Freq. (MHz)	Ant. Factor (dB/m)	Cable Loss (dB)	Reading (dBμV)	Emission Level (dBμV/m)	Limits (dBμV/m)	Margin (dB)	Remark
1	2479.104	28.76	6.44	79.57	114.77	74.00	-40.77	Peak
2	2483.600	28.77	6.45	23.27	58.49	74.00	15.51	Peak
3	2485.200	28.77	6.45	24.56	59.79	74.00	14.21	Peak

- Remarks: 1. Emission Level= Antenna Factor + Cable Loss + Reading.
 2. The emission levels that are 20dB below the official limit are not reported.

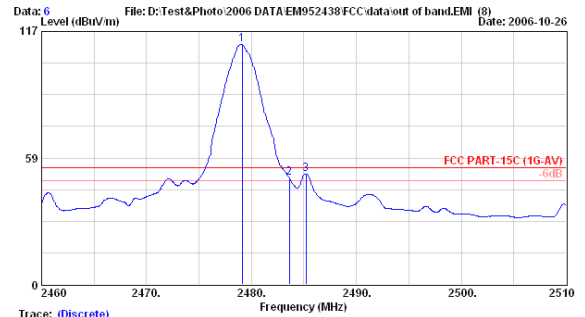

Trace: (Discrete)
 Site no. : A/C Chamber Data no. : 6
 Dis. / Ant. : 3m 3115 Ant. pol. : VERTICAL
 Limit : FCC PART-15C (1G-AV)
 Env. / Ins. : 8593EM 25°C/64% Engineer : Alvin_Yang
 EUT : Radio Control M/N:T3PM-2.4G
 Power Rating : DC 12V
 Test Mode : Stand(CH74)

Trace	Freq. (MHz)	Ant. Factor (dB/m)	Cable Loss (dB)	Reading (dBμV)	Emission Level (dBμV/m)	Limits (dBμV/m)	Margin (dB)	Remark
1	2479.104	28.76	6.44	75.91	111.11	54.00	-57.11	Average
2	2483.600	28.77	6.45	14.08	49.30	54.00	4.70	Average
3	2485.200	28.77	6.45	15.85	51.08	54.00	2.92	Average

- Remarks: 1. Emission Level= Antenna Factor + Cable Loss + Reading.
 2. The emission levels that are 20dB below the official limit are not reported.

4. 6dB BANDWIDTH MEASUREMENT

4.1. Test Equipment

The following test equipment was used during the Emission Bandwidth measurement:

Item	Type	Manufacturer	Model No.	Serial No.	Last Cal.	Next Cal.
1.	Spectrum Analyzer	Agilent	E4446A	US44300366	Aug. 11, 06'	Aug. 10, 07'

4.2. Block Diagram of Test Setup

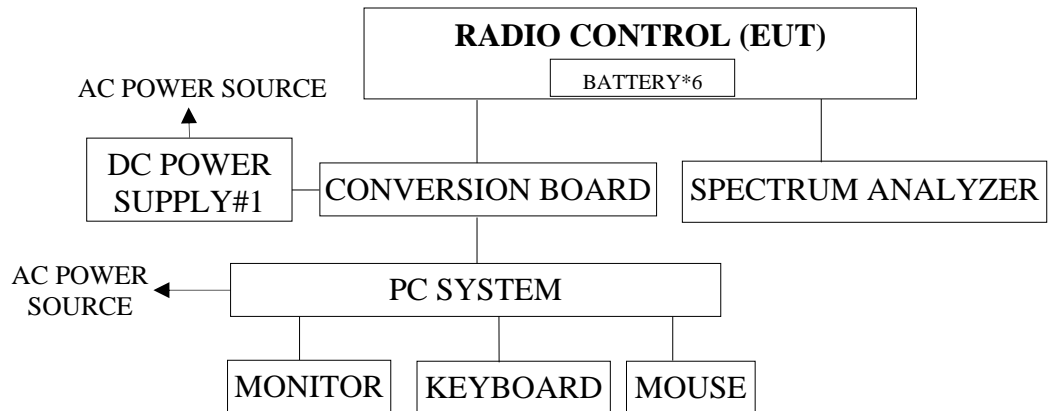

4.3. Specification Limits (§15.247(a)(2))

The minimum 6dB bandwidth shall be at least 500kHz.

4.4. Operating Condition of EUT

The test program “FutabaTerm” was used to enable the EUT to transmit data at different channel frequency individually.

4.5. Test Procedure

The transmitter output was connected to the spectrum analyzer. The bandwidth of the fundamental frequency was measure by spectrum analyzer with 100kHz RBW and 100kHz VBW. The 6dB bandwidth is defined as the total spectrum the power of which is higher than peak power minus 6dB.

4.6. Test Results

PASSED. All the test results are attached in next pages.

(Test Date : Oct. 27, 2006 Temperature : 24 Humidity : 52 %)

Channel	Frequency	6dB Bandwidth
0	2405.376MHz	1.69MHz
38	2442.240MHz	1.70MHz
74	2479.104MHz	1.69MHz

Frequency: 2405.376MHz

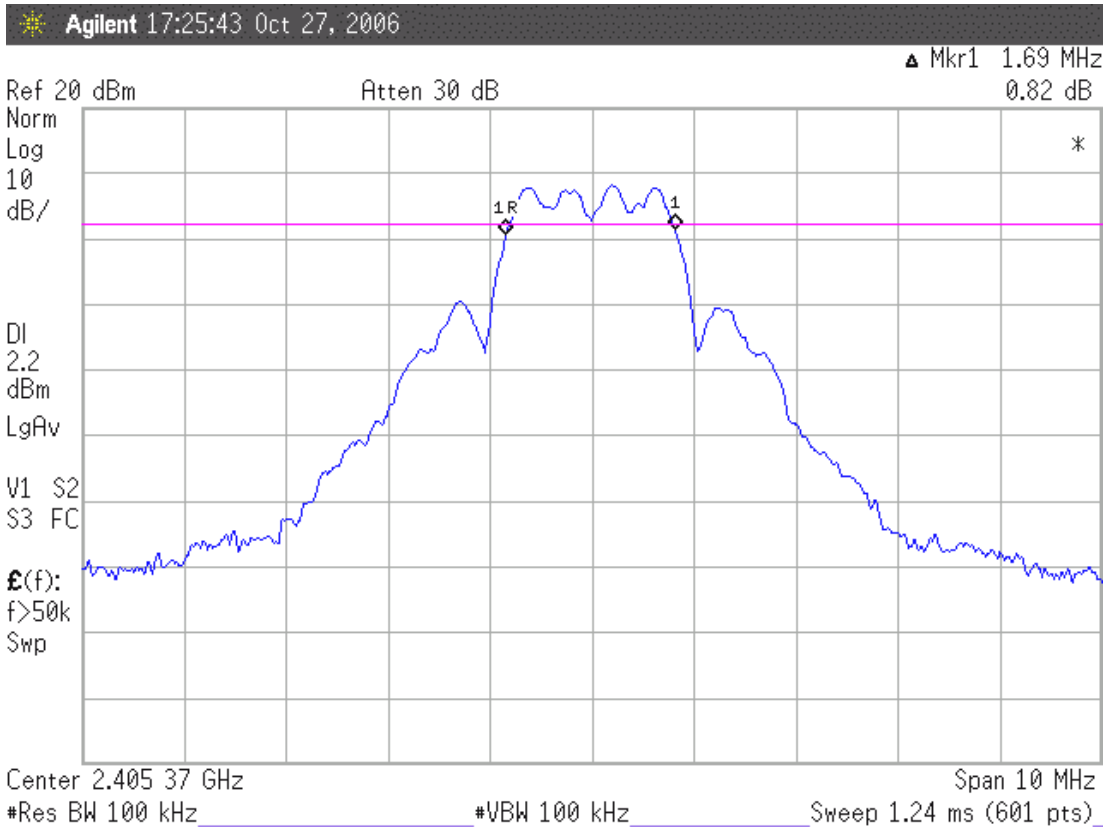

Frequency: 2442.240MHz

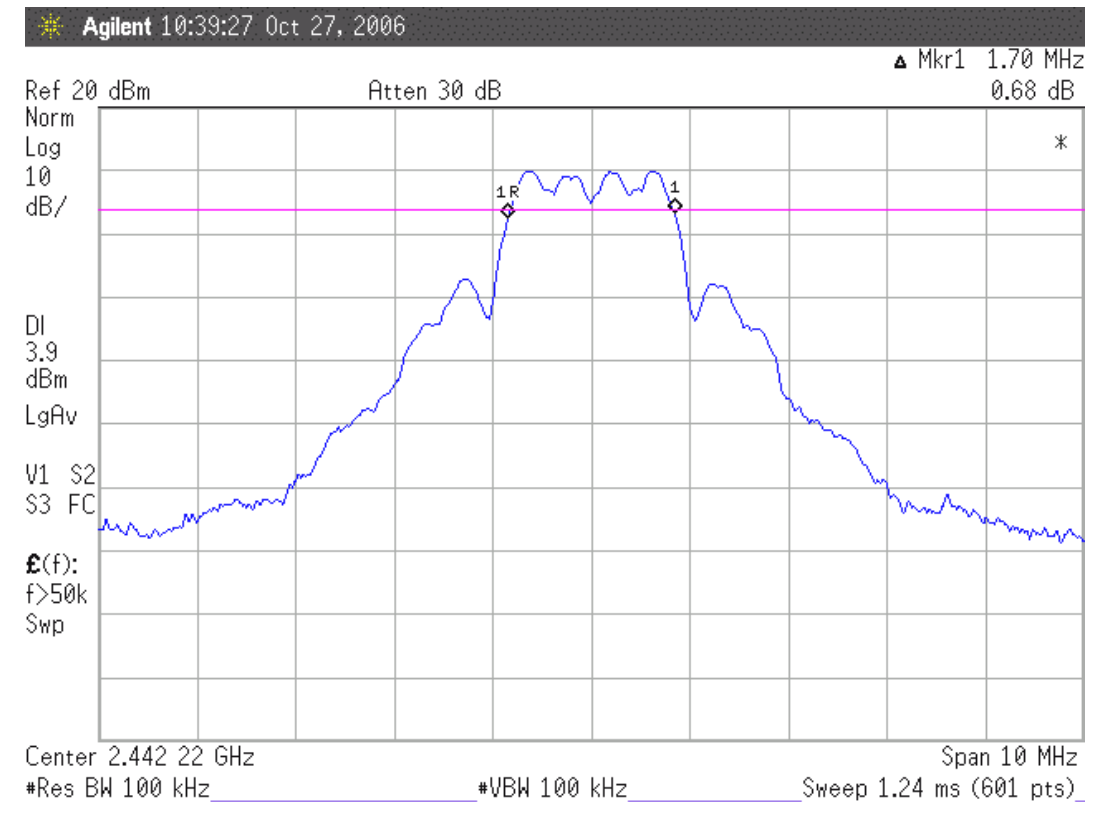

Frequency: 2479.104MHz

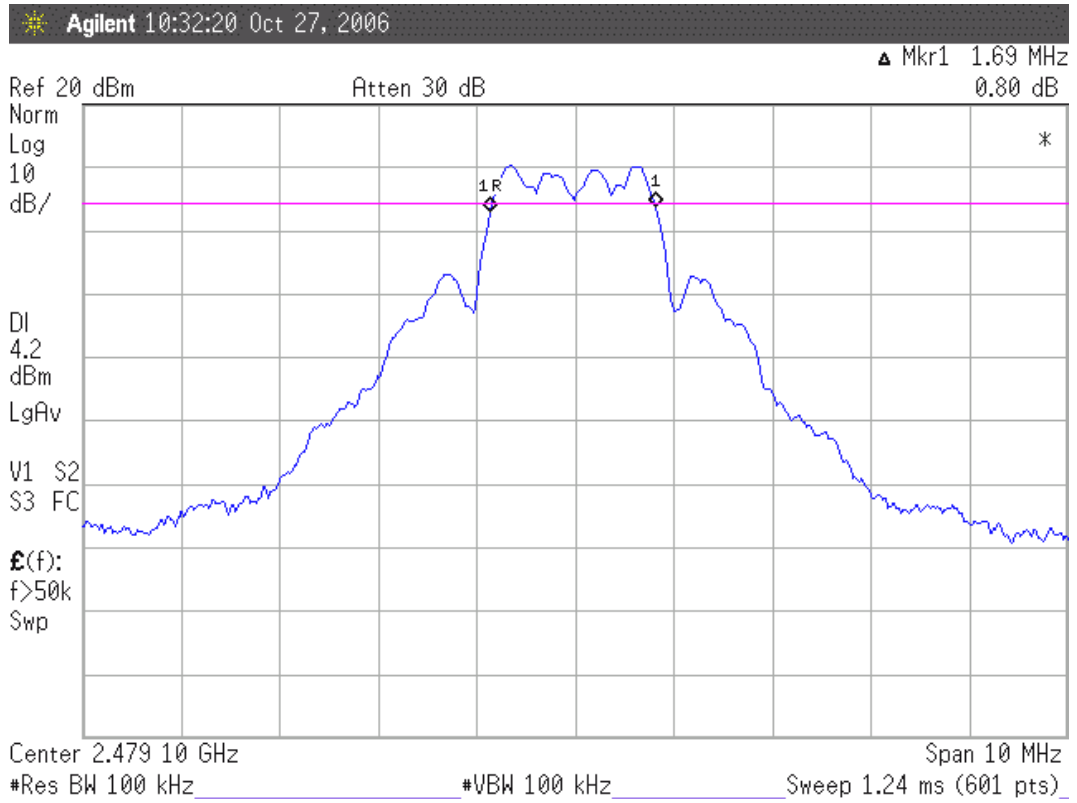

5. MAXIMUM PEAK OUTPUT POWER MEASUREMENT

5.1. Test Equipment

The following test equipment was used during the maximum peak output power measurement:

Item	Type	Manufacturer	Model No.	Serial No.	Last Cal.	Next Cal.
1.	Power Meter	Agilent	E4417A	GB41291797	Feb. 27, 06'	Feb. 26, 07'
2.	Power Sensor	Agilent	E9327A	US40441766	Feb. 27, 06'	Feb. 26, 07'

5.2. Block Diagram of Test Setup

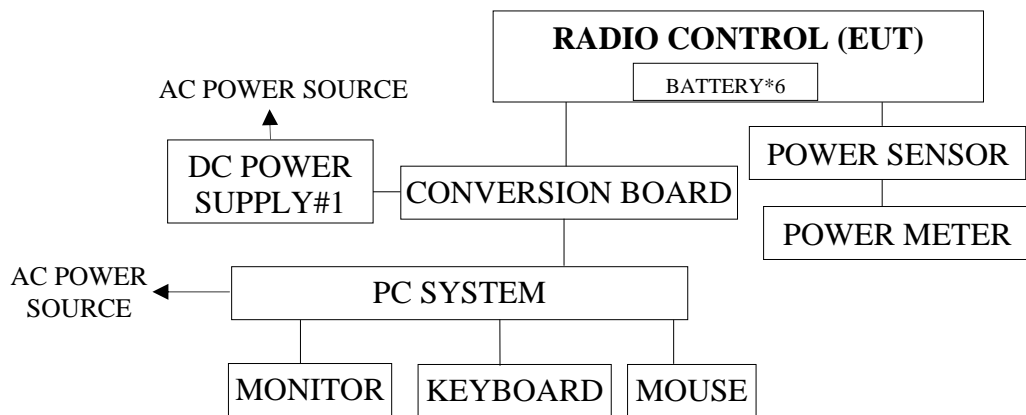

5.3. Specification Limits (§15.247(b)-(3))

The Limits of maximum Peak Output Power for digital modulation in 2400-2483.5MHz is : 1Watt. (30dBm)

5.4. Operating Condition of EUT

The test program “Futaba Term” was used to enable the EUT to transmit data at different channel frequency individually.

5.5. Test Procedure

The transmitter output was connected to the power meter that was designed to detect peak value automatically.

5.6. Test Results

PASSED. All the test results are listed below.

(Test Date : Oct. 27, 2006 Temperature : 24 Humidity : 52 %)

Channel	Frequency	Peak Output Power	Limit
02	2405.376MHz	17.52dBm	30dBm
38	2442.240MHz	17.73dBm	30dBm
74	2479.104MHz	18.42dBm	30dBm

6. EMISSION LIMITATIONS MEASUREMENT

6.1. Test Equipment

The following test equipment was used during the emission limitations test :

Item	Type	Manufacturer	Model No.	Serial No.	Last Cal.	Next Cal.
1.	Spectrum Analyzer	Agilent	E4446A	US44300366	Aug. 11, 06'	Aug. 10, 07'

6.2. Block Diagram of Test Setup

The same as section.4.2.

6.3. Specification Limits (§15.247(c))

In any 100kHz bandwidth outside the frequency band in which the spread spectrum or digitally modulated intentional radiator is operating, the radio frequency power that is produced by the intentional radiator shall be at least 20dB below that in the 100kHz bandwidth within the band that contains the highest level of the desired power, based on either an RF conducted or a radiated measurement. Attenuation below the general limits specified in Section 15.209(a) is not required. In addition, radiated emissions which fall in restricted bands, as defined in Section 15.205(a), must also comply with the radiated emission limits specified in Section 15.209(a) (See Section 15.205(c)).(This test result attaching to §3.6.3)

6.4. Operating Condition of EUT

The test program “Futaba Term” was used to enable the EUT to transmit data at different channel frequency individually.

6.5. Test Procedure

The transmitter output was connected to the spectrum analyzer. The bandwidth of the fundamental frequency was measure by spectrum analyzer with 100kHz RBW and 100kHz VBW.

6.6. Test Results

PASSED. The testing data was attached in the next pages.

(Test Date : Oct. 27, 2006 Temperature : 24 Humidity : 52 %)

1. 2405.376MHz: During 30MHz~25GHz bandwidth. In the 1.61GHz, the -40.88dBm is max value that is lower than 20dB of primary channel.
2. 2442.240MHz: During 30MHz~25GHz bandwidth. In the 1.63GHz, the -44.36dBm is max value that is lower than 20dB of primary channel.
3. 2479.104MHz: During 30MHz~25GHz bandwidth. In the 1.65GHz, the -38.33dBm is max value that is lower than 20dB of primary channel.

Note: The peak above the limit line is the carrier frequency.

Frequency: 2405.376MHz

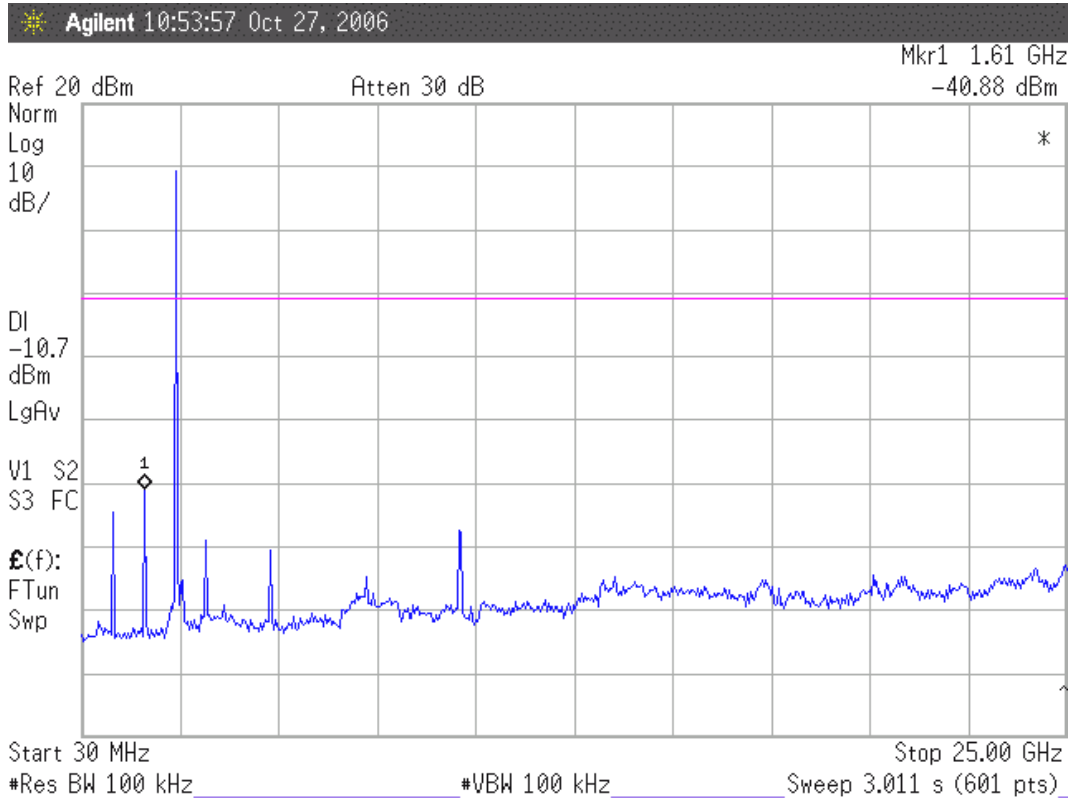

Frequency: 2442.240MHz

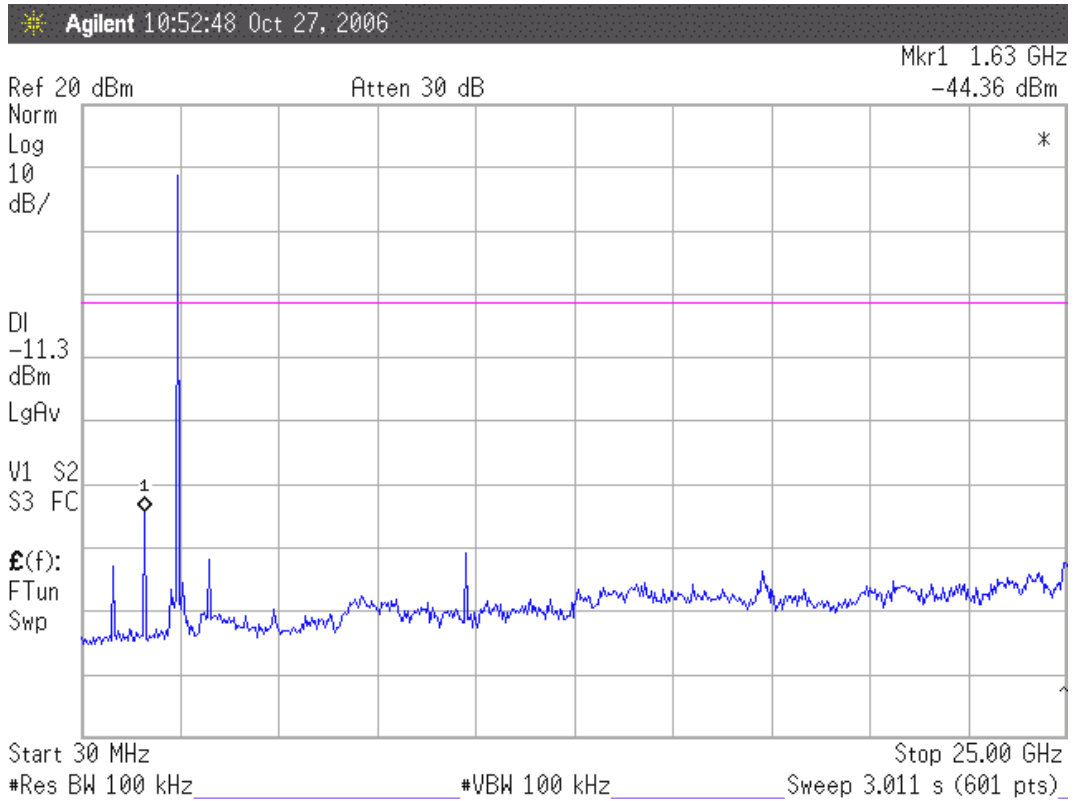

7. BAND EDGES MEASUREMENT

7.1. Test Equipment

The following test equipment was used during the band edges measurement:

Item	Type	Manufacturer	Model No.	Serial No.	Last Cal.	Next Cal.
1.	Spectrum Analyzer	Agilent	E4446A	US44300366	Aug. 11, 06'	Aug. 10, 07'

7.2. Block Diagram of Test Setup

The same as section.4.2.

7.3. Specification Limits (§15.247(c))

The highest level should be at least 20 dB below that in the 100kHz bandwidth.

7.4. Operating Condition of EUT

The test program “Futaba Term” was used to enable the EUT to transmit data at different channel frequency individually.

7.5. Test Procedure

The transmitter output was connected to the spectrum analyzer. Set both RBW and VBW of spectrum analyzer to 100kHz with suitable frequency span including 100kHz bandwidth from band edge.

7.6. Test Results

PASSED. All the test results are attached in next pages.

(Test Date : Oct. 27, 2006 Temperature : 24 Humidity : 52 %)

1. Below Band edge: The highest emission level is -46.63dBm on 2.48353GHz .
2. Upper Band edge : The highest emission level is -43.93dBm on 2.39997GHz .

Below Band edge

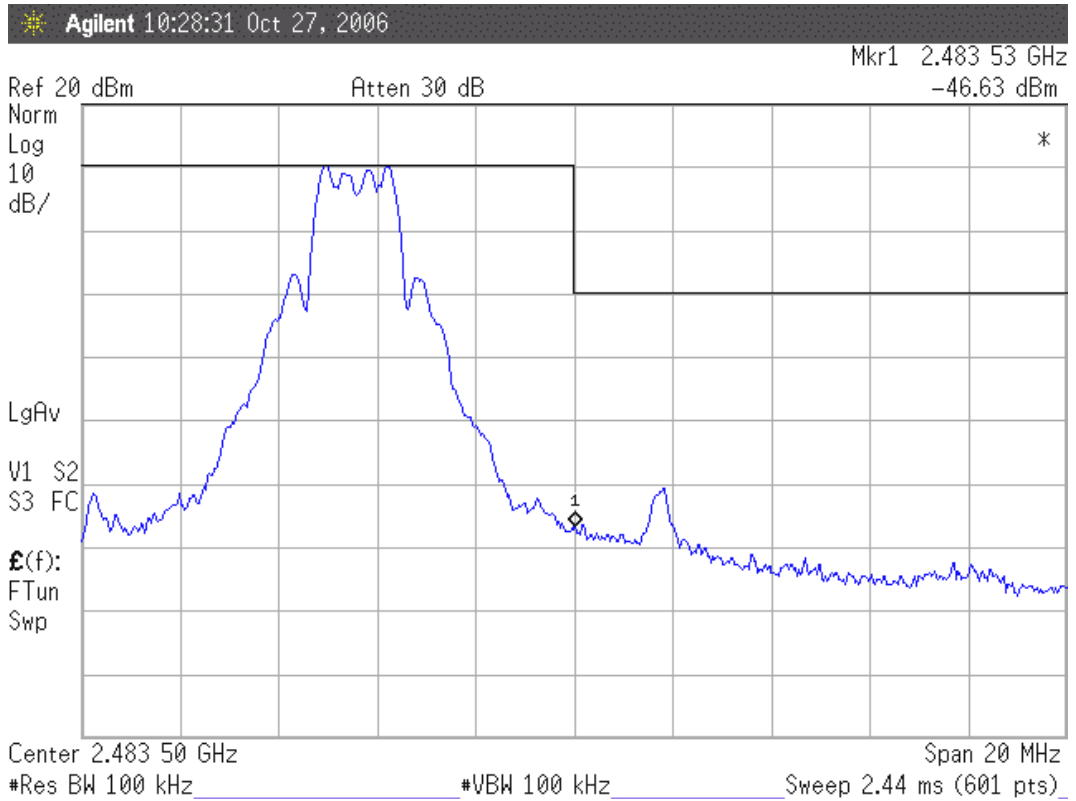

Upper Band edge

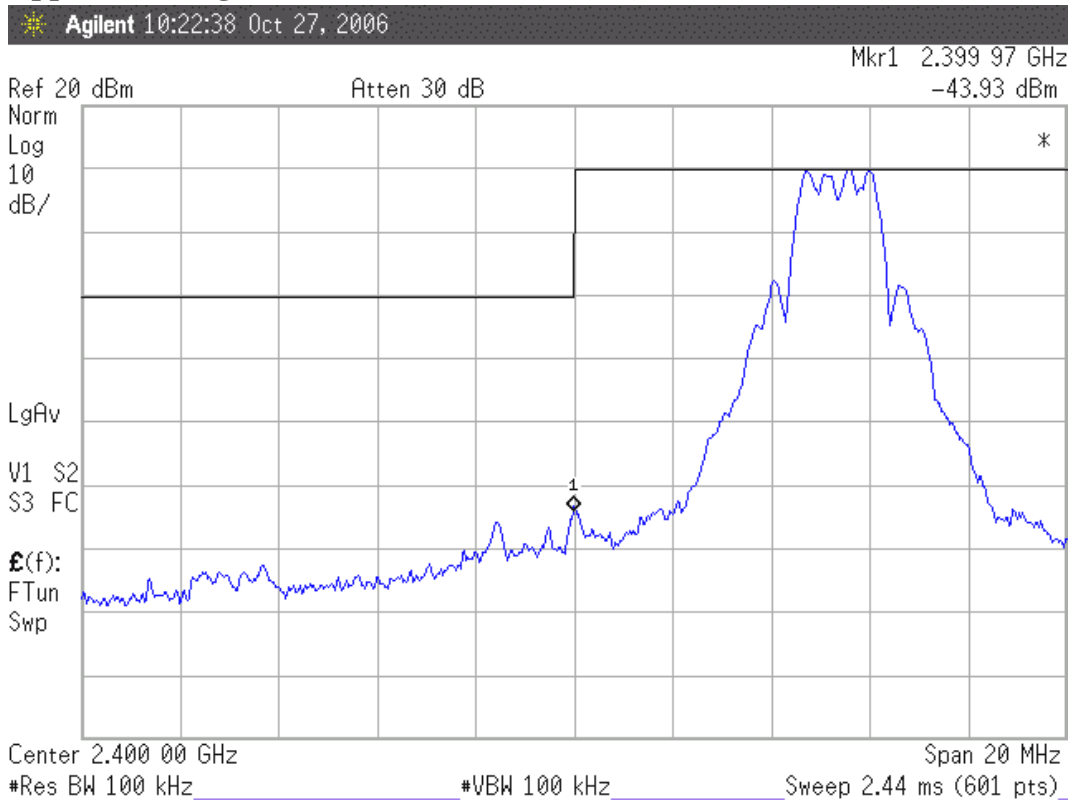

8. POWER SPECTRAL DENSITY MEASUREMENT

8.1. Test Equipment

The following test equipment was used during the power spectral density measurement:

Item	Type	Manufacturer	Model No.	Serial No.	Last Cal.	Next Cal.
1.	Spectrum Analyzer	Agilent	E4446A	US44300366	Aug. 11, 06'	Aug. 10, 07'

8.2. Block Diagram of Test Setup

The same as section.4.2.

8.3. Specification Limits (§15.247(d))

The peak power spectral density conducted from the intentional radiator to the antenna shall not be greater than 8dBm in any 3kHz band.

8.4. Operating Condition of EUT

The test program “Futaba Term” was used to enable the EUT to transmit data at different channel frequency individually.

8.5. Test Procedure

The transmitter output was connected to the spectrum analyzer. The bandwidth of the fundamental frequency was measured with the spectrum analyzer using 3kHz RBW and 30kHz VBW, set sweep time = span/3kHz.

8.6. Test Results

PASSED. All the test results are attached in next pages.

(Test Date : Oct. 27, 2006 Temperature : 24 Humidity : 52 %)

Channel	Frequency	Power Spectral Density	Limit
02	2405.376MHz	0.59dBm	8dBm
38	2442.240MHz	0.32dBm	8dBm
74	2479.104MHz	1.24dBm	8dBm

Frequency: 2405.376MHz

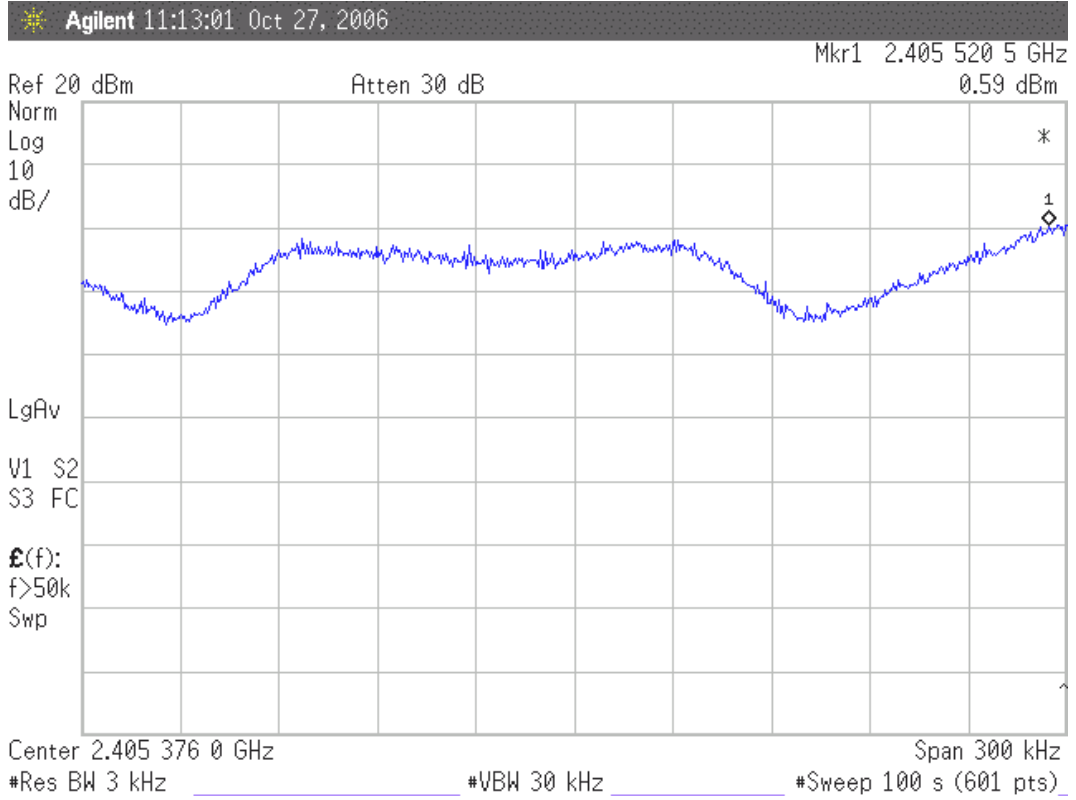

Frequency: 2442.240MHz

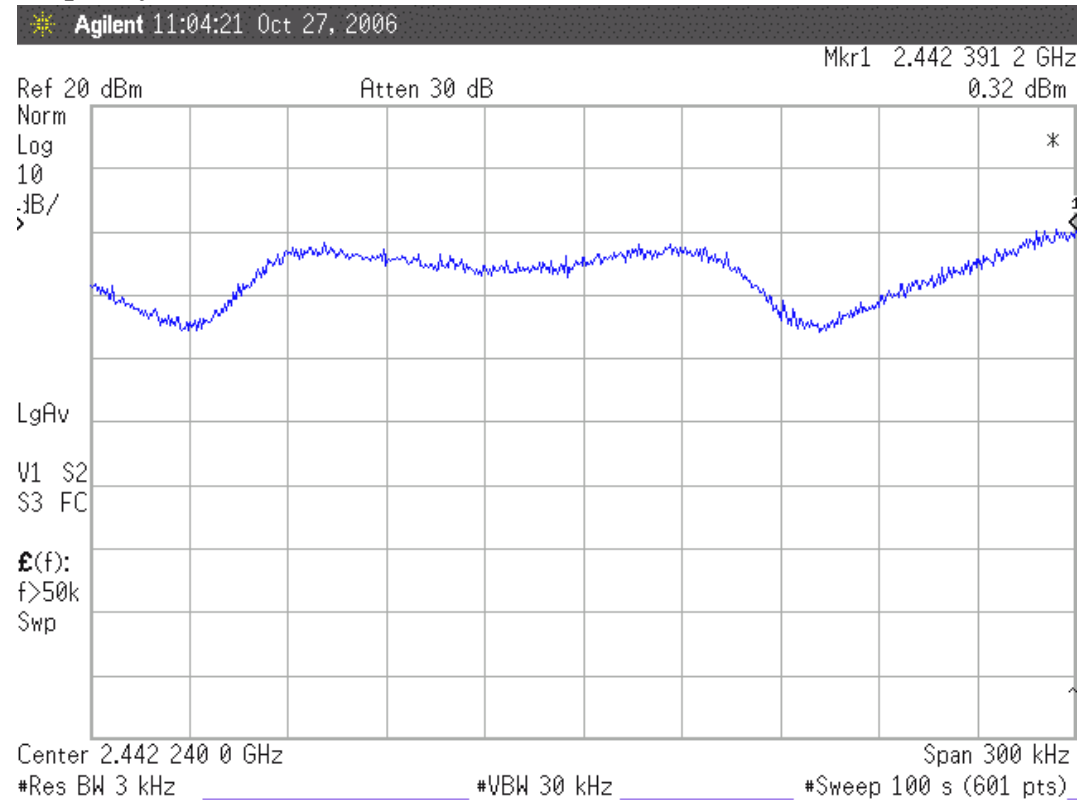

Frequency: 2479.104MHz

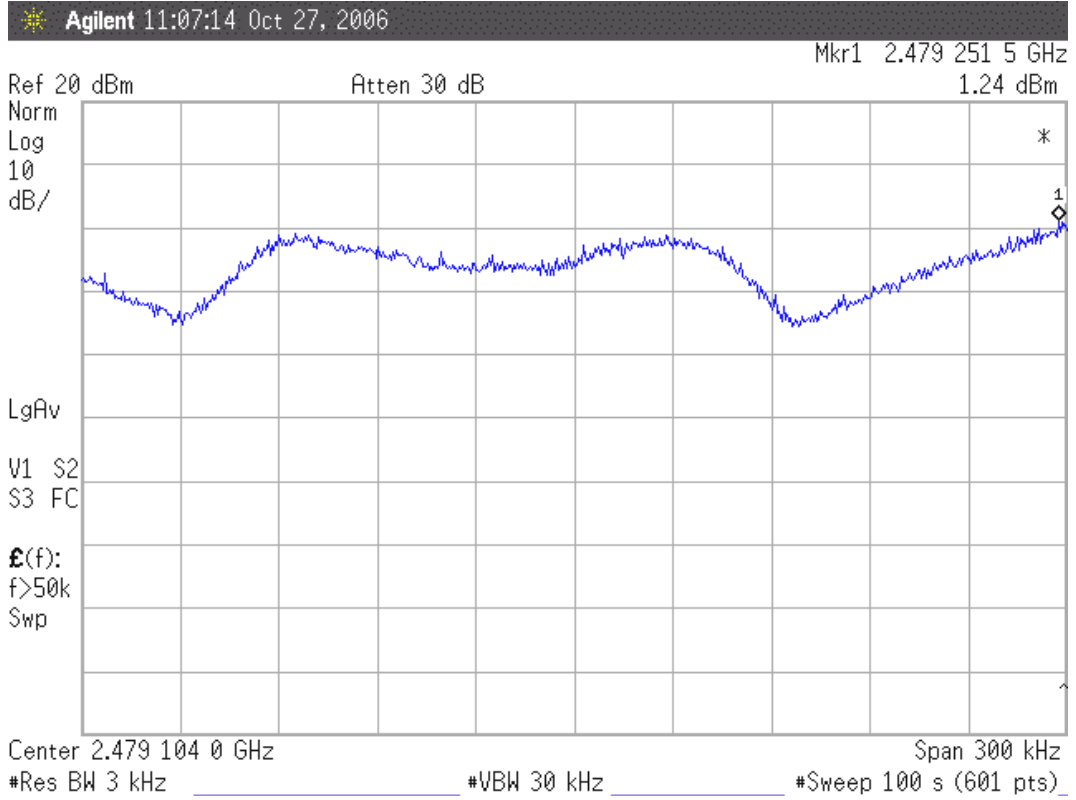

9. DEVIATION TO TEST SPECIFICATIONS

【NONE】