

T18MZ WC

18 CHANNEL COMPUTER SYSTEM



INSTRUCTION MANUAL

Futaba® *Digital Proportional R/C System*

1M23N26421

TABLE OF CONTENTS

INTRODUCTION	4	● Telemetry System.....	34
● Support and Service	4	BASIC OPERATION	35
● Application, Export, and Modification... 5		● Battery Charging	35
● Definitions of Symbols.....	6	● How to turn ON/OFF the transmitter . 36	
● Safety Precautions (do not operate without reading)	6	● Registration of the user's name	37
BEFORE USE	10	● Home screen	38
● Features of 18MZ-WC	10	● Home 2 screen	39
● Contents and Technical Specifications 12		● User Menu.....	39
● Accessories	13	MODEL BASIC SETTING PROCEDURE 40	
● Transmitter controls	14	● Airplane/glider basic setting procedure40	
Cautions on handling antenna	14	● Helicopter basic setting procedure..... 42	
LED monitor	15	● Servos connection by model type	46
Switch reallocation (SA-SH)	15	FUNCTIONS OF SYSTEM MENU	51
Volume (LD, CD, RD).....	16	Trainer.....	52
Slide Lever (LST, LS, RS, RST)	16	Display	55
Digital trim (T1-T6)	16	Date and Time	56
Touch panel / Rotary key / Direct key . 17		User Name	57
Touch panel lock.....	17	Switch	58
Stick Adjustment	18	H/W Setting	59
Battery exchange	19	Sound Volume	61
Back lid	21	Player	62
Connector / Plug	22	Camera.....	63
SD card / USB port	23	S.BUS Servo	64
Camera function	24	Information	67
● Receiver R7008SB nomenclature..... 25		Unit System	68
Connector.....	25	Range Check	69
Link / Mode Switch	25	FUNCTIONS OF LINKAGE MENU	70
Extra Voltage Connector	25	Servo Monitor.....	71
Connection of a receiver battery	26	Model Select	72
Connection example	26	Model Type	73
R7008SB CH Mode.....	27	Picture.....	75
● Servo(Optional) / Toolbox.....	28	Sound.....	76
● Receiver's Antenna Installation	29	System Type.....	78
● Safety precautions when installing receiver and servos	30	System Type selection	78
● S.BUS Installation	31	Receiver linking	78
● S.BUS Wiring example.....	32	Dual receiver function	78
● S.BUS2 System.....	33	Telemetry function	78
● S.BUS device setting.....	33		

D/L Interval	78	AIL to Brake FLP.....	129
Battery fail-safe voltage setup	78	AIL to RUD	130
Linking method (T18MZ-WC ↔ R7008SB)	79	Airbrake to ELE.....	131
The example for choosing System Type	80	RUD to AIL	132
Function	81	Camber Mix	133
Sub-Trim	83	ELE to Camber	135
Servo Reverse	84	Camber FLP to ELE.....	136
Fail Safe	85	Butterfly.....	137
End Point (ATV)	86	Trim Mix 1/2.....	139
Throttle Cut (Airplane/helicopter only)87		Airbrake	141
Idle Down (Airplane/helicopter only)..88		Gyro (Airplane).....	143
Swash Ring (Helicopter only).....89		V-tail	144
Swash (Helicopter only).....90		Ailevator.....	145
Timer	92	Winglet.....	146
Dial Monitor.....	94	Motor	147
Function Name	95	RUD to ELE	148
Telemetry	96	Snap Roll	149
Audible telemetry information	97	Multi Engine	150
Receiver Battery Display	98	Acceleration	151
Temperature Display	99	● Helicopter Functions.....	152
RPM Display	99	PIT Curve	153
Altitude Display	100	THR Curve	156
GPS Display	101	Acceleration	158
Voltage Display.....	102	Throttle Hold	159
Current / Voltage / Capacity Display.....	103	Swash Mix	160
Servo sensor Display	104	Throttle Mix.....	161
Sensor.....	105	PIT to Needle	162
Sensor Name.....	110	PIT to RUD	163
Telemetry Setting	111	Gyro	164
Warning	112	Governor	165
Data Reset.....	113	Throttle Limiter	166
Condition Hold (Helicopter only)	114		
FUNCTIONS OF MODEL MENU	115	COMMON OPERATIONS USED IN	
Servo Monitor (Linkage Menu71)		FUNCTION SETUP SCREEN	167
Condition Select.....	116	Flight conditions	167
AFR (D/R)	118	Fine tuning VR setting	167
Prog. Mixes (Program mixing)	120	Servo speed.....	168
Fuel Mixture	123	Curve setting	169
● Airplane/Glider Functions.....	124	Switch selection.....	173
AIL Differential	126	UPDATING	177
Flap Setting	127	T14MZ → T18MZ-WC MODEL DATA	
AIL to Camber FLP.....	128	CONVERSION.....	178

INTRODUCTION

Thank you for purchasing a Futaba® FASSTest-2.4GHz* 18MZ-WC series digital proportional R/C system. This system is extremely versatile and may be used by beginners and pros alike. In order for you to make the best use of your system and to fly safely, please read this manual carefully. If you have any difficulties while using your system, please consult the manual, our online Frequently Asked Questions (on the web pages referenced below), your hobby dealer, or the Futaba Service Center.

Due to unforeseen changes in production procedures, the information contained in this manual is subject to change without notice.

Support and Service: It is recommended to have your Futaba equipment serviced annually during your hobby's "off season" to ensure safe operation.

IN NORTH AMERICA

Please feel free to contact the Futaba Service Center for assistance in operation, use and programming. Please be sure to regularly visit the 18MZ-WC Frequently Asked Questions web site at www.futaba-rc.com/faq/. This page includes extensive programming, use, set up and safety information on the 18MZ-WC radio system and is updated regularly. Any technical updates and US manual corrections will be available on this web page. If you do not find the answers to your questions there, please see the end of our F.A.Q. area for information on contacting us via email for the most rapid and convenient response.

Don't have Internet access? Internet access is available at no charge at most public libraries, schools, and other public resources. We find internet support to be a fabulous reference for many modelers as items can be printed and saved for future reference, and can be accessed at any hour of the day, night, weekend or holiday. If you do not wish to access the internet for information, however, don't worry. Our support teams are available Monday through Friday 8-5 Central time to assist you.

FOR SERVICE ONLY:

Futaba Service Center
3002 N. Apollo Drive, Suite 1
Champaign, IL 61822
Phone: 217-398-0007
www.futaba-rc.com/service.html
Email: futabaservice@hobbico.com

FOR SUPPORT : (PROGRAMMING AND USER QUESTIONS)

Please start here for answers to most questions:
www.futaba-rc.com/faq/
Fax: 217-398-7721
Phone: 217-398-8970 option 2

OUTSIDE NORTH AMERICA

Please contact your Futaba importer in your region of the world to assist you with any questions, problems or service needs.

Please recognize that all information in this manual, and all support availability, is based upon the systems sold in North America only. Products purchased elsewhere may vary. Always contact your region's support center for assistance.

Application, Export, and Modification

1. This product may be used for model airplane or surface (boat, car, robot) use. It is not intended for use in any application other than the control of models for hobby and recreational purposes. The product is subject to regulations of the Ministry of Radio/Telecommunications and is restricted under Japanese law to such purposes.
2. Exportation precautions:
 - (a) When this product is exported from the country of manufacture, its use is to be approved by the laws governing the country of destination which govern devices that emit radio frequencies. If this product is then re-exported to other countries, it may be subject to restrictions on such export. Prior approval of the appropriate government authorities may be required. If you have purchased this product from an exporter outside your country, and not the authorized Futaba distributor in your country, please contact the seller immediately to determine if such export regulations have been met.
 - (b) Use of this product with other than models may be restricted by Export and Trade Control Regulations, and an application for export approval must be submitted. This equipment must not be utilized to operate equipment other than radio controlled models.
3. Modification, adjustment, and replacement of parts: Futaba is not responsible for unauthorized modification, adjustment, and replacement of parts on this product. Any such changes may void the warranty.

Compliance Information Statement (for U.S.A.)

This device, trade name Futaba Corporation, complies with part 15 of the FCC Rules. Operation is subject to the following three conditions:

- (1) This device may not cause harmful interference, and
- (2) This device must accept any interference received, including interference that may cause undesired operation.
- (3) This module meets the requirements for a mobile device that may be used at separation distances of more than 20cm from human body.

To meet the RF exposure requirements of the FCC this device shall not be co-located with another transmitting device.

The responsible party of this device compliance is:

Futaba Service Center

3002 N Apollo Drive Suite 1, Champaign, IL 61822 U.S.A.

TEL (217)398-8970 or E-mail: support@hobbico.com (Support)

TEL (217)398-0007 or E-mail: futabaservice@hobbico.com (Service)



The RBRC. SEAL on the nickel-cadmium battery contained in Futaba products indicates that Futaba Corporation of America is voluntarily participating in an industry-wide program to collect and recycle these batteries at the end of their useful lives, when taken out of service within the United States. The RBRC. program provides a convenient alternative to placing used nickel-cadmium batteries into the trash or municipal waste system, which is illegal in some areas.

(for USA)

You may contact your local recycling center for information on where to return the spent battery. Please call 1-800-8BATTERY for information on Ni-Cd battery recycling in your area. Futaba Corporation involvement in this program is part of its commitment to protecting our environment and conserving natural resources.

*RBRC is a trademark of the Rechargeable Battery Recycling Corporation.

Federal Communications Commission Interference Statement (for U.S.A.)

This equipment has been tested and found to comply with the limits for a Class B digital device, pursuant to Part 15 of the FCC Rules. These limits are designed to provide reasonable protection against harmful interference in a residential installation.

This equipment generates, uses and can radiate radio frequency energy and, if not installed and used in accordance with the instructions, may cause harmful interference to radio communications. However, there is no guarantee that interference will not occur in a particular installation. If this equipment does cause harmful interference to radio or television reception, which can be determined by turning the equipment off and on, the user is encouraged to try to correct the interference by one or more of the following measures:

- Reorient or relocate the receiving antenna.
- Increase the separation between the equipment and receiver.
- Connect the equipment into an outlet on a circuit different from that to which the receiver is connected.
- Consult the dealer or an experienced radio/TV technician for help.

CAUTION:

To assure continued FCC compliance:

Any changes or modifications not expressly approved by the grantee of this device could void the user's authority to operate the equipment.

Exposure to Radio Frequency Radiation

To comply with FCC RF exposure compliance requirements, a separation distance of at least 20cm must be maintained between the antenna of this device and all persons.

This device must not be co-located or operating in conjunction with any other antenna or transmitter.

Meaning of Special Markings

Pay special attention to safety where indicated by the following marks:

- ⚠ **DANGER** - Procedures which may lead to dangerous conditions and cause death/serious injury if not carried out properly.
- ⚠ **WARNING** - Procedures which may lead to a dangerous condition or cause death or serious injury to the user if not carried out properly, or procedures where the probability of superficial injury or physical damage is high.
- ⚠ **CAUTION** - Procedures where the possibility of serious injury to the user is small, but there is a danger of injury, or physical damage, if not carried out properly.

⊘ = Prohibited ⓘ = Mandatory

Warning: Always keep electrical components away from small children.

FLYING SAFETY

⚠ WARNING

To ensure the safety of yourself and others, please observe the following precautions:

- ⓘ **Have regular maintenance performed.** Although your 18MZ-WC protects the model memories with non-volatile EEPROM memory (which does not require periodic replacement) and not a battery, the transmitter still should have regular checkups for wear and tear. We recommend sending your system to the Futaba Service Center annually during your non-flying-season for a complete checkup and service.

Battery

- ❗ **Charge the batteries!** (See Charging the batteries, for details.) Always recharge the transmitter and receiver batteries before each flying session. A low battery will soon die potentially, causing loss of control and a crash. When you begin your flying session, reset your T18MZ-WC's built-in timer, and during the session pay attention to the duration of usage.
- ❗ **Stop flying long before your batteries become low on charge. Do not rely on your radio's low battery warning systems, intended only as a precaution, to tell you when to recharge. Always check your transmitter and receiver batteries prior to each flight.**

Where to Fly

We recommend that you fly at a recognized model airplane flying field. You can find model clubs and fields by asking your nearest hobby dealer, or in the US by contacting the Academy of Model Aeronautics.

You can also contact the national Academy of Model Aeronautics (AMA), which has more than 2,500 chartered clubs across the country. Through any one of them, instructor training programs and insured newcomer training are available. Contact the AMA at the address or toll-free phone number below.

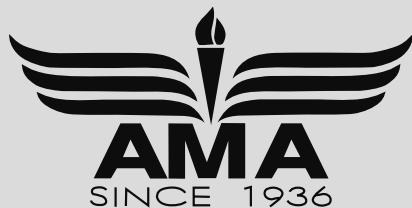

Academy of Model Aeronautics

5161 East Memorial Drive

Muncie, IN 47302

Tele. (800) 435-9262

Fax (765) 289-4248

or via the Internet at <http://www.modelaircraft.org>

- ❗ **Always pay particular attention to the flying field's rules**, as well as the presence and location of spectators, the wind direction, and any obstacles on the field. Be very careful flying in areas near power lines, tall buildings, or communication facilities as there may be radio interference in their vicinity.

Lithium polymer (Lipo) Battery Safety and Handling instructions

IMPORTANT!

Use only the **Futaba special charger** included with this set or other chargers approved by Futaba to charge the Lipo batteries in the T18MZ-WC transmitter included with this set.

It is important to understand the operating characteristics of Lipo batteries. Always read the specifications printed on the label of your Lipo battery and charger prior to use. Failure to follow the preceding precautions can quickly result in severe, permanent damage to the batteries and its surroundings and possibly result in a **FIRE!**

IMPORTANT PRECAUTIONS

- ⊗ Do not attempt to disassemble Lipo packs or cells.
- ⊗ Do not allow Lipo cells to come in contact with moisture or water at any time.
- ❗ Always provide adequate ventilation around Lipo batteries during charge, discharge, while in use, and during storage.
- ⊗ Do not leave a Lipo battery unattended at any time while being charged or discharged.
- ⊗ Do not attempt to charge Lipo batteries with a charger that is NOT designed for Lipo batteries, as permanent damage to the battery and charger could result.
- ❗ Always charge Lipo batteries in a fireproof location. Do not charge or discharge Lipo batteries on carpet, a cluttered workbench, near paper, plastic, vinyl, leather or wood, or inside an R/C model or full-sized automobile! Monitor the charge area with a smoke or fire alarm.
- ⊗ Do not charge Lipo batteries at currents greater than the “1C” rating of the battery (“C” equals the rated capacity of the battery).
- ⊗ Do not allow Lipo cells to overheat at any time! Cells which reach greater than 140 degrees Fahrenheit (60°C) should be placed in a fireproof location.
- ❗ Lipo cells will not charge fully when too cold or show full charge.
- ❗ It is normal for the batteries to become warm during charging, but if the charger or battery becomes excessively hot disconnect the battery from the charger immediately!! Always inspect a battery which has previously overheated for potential damage, and do not re-use if you suspect it has been damaged in any way.
- ⊗ Do not use a Lipo battery if you suspect physical damage has occurred to the pack. Carefully inspect the battery for even the smallest of dents, cracks, splits, punctures or damage to the wiring and connectors. DO NOT allow the battery’s internal electrolyte to get into eyes or on skin—wash affected areas immediately if they come in contact with the electrolyte. If in doubt, place the battery in a fire-proof location for at least 30 minutes.
- ⊗ Do not store batteries near an open flame or heater.
- ⊗ Do not discharge Lipo batteries at currents which exceed the discharge current rating of the battery.
- ❗ Always store Lipo cells/packs in a secure location away from children.

Secure Digital (SD) Memory Card Handling Instructions (SD card is not included with this set)

- ⊗ Never remove the SD card or turn off power while entering data.
- ⊗ Never store the SD card where it may be subject to strong static electricity or magnetic fields.
- ⊗ Do not expose the SD card to direct sunlight, excessive humidity or corrosive environments.
- ⊗ Do not expose the SD card to dirt, moisture, water or fluids of any kind.
- ❗ Be certain to insert the SD card in the correct direction.

At the flying field

To prevent possible damage to your radio gear, turn the power switches on and off in the proper sequence:

1. Pull throttle stick to idle position, or otherwise disarm your motor/engine.
2. Turn on the transmitter power and allow your transmitter to reach its home screen.
3. Confirm that the proper model memory has been selected.
4. Turn on your receiver power.
5. Test all controls. If a servo operates abnormally, don't attempt to fly until you determine the cause of the problem.
Test to ensure that the Fail Safe settings are correct after adjusting them. Turn the transmitter off and confirm the proper surface/throttle movements. Turn the transmitter back on.
6. Start your engine.
7. Complete a full range check.
8. After flying, bring your throttle stick to idle position, engage any kill switches or otherwise disarm your motor/engine.
9. Turn off receiver power.
10. Turn off transmitter power.

If you do not turn on your system in this order, you may damage your servos or control surfaces, flood your engine, or in the case of electric-powered or gasoline-powered models, the engine may unexpectedly turn on and cause a severe injury.

- ❶ While you are getting ready to fly, if you place your transmitter on the ground, be sure that the wind won't tip it over. If it is knocked over, the throttle stick may be accidentally moved, causing the engine to speed up. Also, damage to your transmitter may occur.
- ❶ In order to maintain complete control of your aircraft it is important that it remains visible at all times. Flying behind large objects such as buildings, grain bins, etc. is not suggested. Doing so may result in the reduction of the quality of the radio frequency link to the model.
- ⊘ Do not grasp the transmitter's antenna during flight. Doing so may degrade the quality of the radio frequency transmission.
- ❶ As with all radio frequency transmissions, the strongest area of signal transmission is from the sides of the transmitter's antenna. As such, the antenna should not be pointed directly at the model. If your flying style creates this situation, easily move the antenna to correct this situation.

BEFORE USE

FEATURES

FASSTest system

The T18MZ-WC transmitter adopted the bidirectional communication system "FASSTest". Data from the receiver can be checked in your transmitter. FASSTest is a maximum 18 channels (linear 16 channels + switch 2 channels) 2.4GHz dedicated system.

S.BUS2 system

By using the S.BUS2 system multiple servos, gyros and telemetry sensors are easily installed with a minimum amount of cables.

Windows CE

T18MZ-WC utilizes the world famous Microsoft Windows CE, which offers outstanding dependability and valuable resources.

Color LCD

T18MZ-WC has a HVGA (640x240 pixels) full color backlight LCD touchscreen. The screen is manufactured of a transfective construction which enables both indoor and outdoor visibility.

Music Play

T18MZ-WC can playback WMA (Windows Media Audio) files on a SD-Card. You can enjoy music by the internal speaker or stereo headphones from the earphone jack. A switch can be assigned to start/stop your music.

Voice Recording

You can record your own voice using the internal microphone and then play back commands assigned to certain switches. Recording time is 3 seconds maximum and 24 voice files can be stored.

Camera function + picture paste function

The transmitter has a 0.03M megapixels digital camera function. Picture files can be inserted as pictures of each model, and shown on the home screen. Identification during model selection is easy and convenient. (File type: bmp, JPEG, picture size: 158x80 pixels)

Secure Data (SD)

Model data, music files, voice files and picture files can be stored on optional SD card. The SD card is also used when updating the software/features of the T18MZ-WC.

High capacity lithium polymer battery (3500mAH)

The high capacity Lithium Polymer battery gives you extended flight time.

USB connection

A USB connector is built in. A commercial PC mouse and keyboard can be used. The model data can also be stored in a USB memory flash drive.



Editing

The touch panel and rotary encoder editing system allows you to edit your model in the manner that is easiest for you.

Functions

The internal dual processors operate the many 18MZ-WC functions and optimize the response time. Most of the mixing functions are operated by curves which give you very precise settings.

Stick

Each axis is supported by dual ball bearings. This allows for finer and more precise operation, the potentiometers also offer a very long lifespan.

Replaceable switches

You can replace 8 of the toggle switches on the right and left shoulder, with optional switches (two position, three position, and momentary etc.).

Vibration function

Low voltage and other alarms are generated by a vibration motor. Alarms or vibrations to be used can be selected by the owner.



R7008SB

The system comes with the R7008SB S.BUS2 Dual Antenna Diversity receiver featuring bi-directional communication.

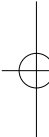

Contents and Technical Specifications

(Specifications and ratings are subject to change without notice.)

Your 18MZ-WC (packaged with a S.BUS receiver) includes the following components:

- T18MZ-WC Transmitter
- R7008SB Receiver
- LT2F3500XH Lithium-polymer battery & AC adapter
- Switch harness
- Tool Box (includes special jig for adjustment)
- Neck strap
- Transmitter case

The set contents depend on the type of set.

Transmitter T18MZ-WC

Operating system: 2-stick, 18 channels, 2.4GHz
FASSTest /FASST/S-FHSS/T-FHSS system

Transmitting frequency: 2.4 GHz

Power supply: 7.4V LT2F3500 Li-polymer battery

Current drain: 1 ampere maximum (RF power on and
back light on) 700mA average

Receiver R7008SB

(FASSTest, S.BUS2, Diversity)

Receiving frequency: 2.4 GHz FASSTest system

Power requirement: 6.6 V LiFe battery

Current drain: 75 mA

Size: 24.9x47.3x14.3 mm

Weight: 10.9 g

Accessories

The following additional accessories are available from your dealer. Refer to a Futaba catalog for more information:

- LT2F3500XH Transmitter battery pack - the (3500mAh) transmitter Lithium-polymer battery pack may be easily exchanged with a fresh one to provide enough capacity for extended flying sessions.
- Trainer cord - the optional training cord may be used to help a beginning pilot learn to fly easily by placing the instructor on a separate transmitter. Note that the T18MZ-WC transmitter may be connected to another T18MZ-WC system, as well as to any other models of Futaba transmitters. The T18MZ-WC transmitter uses the newer "Micro" rectangular type cord plug. Both Micro- to-Micro and Micro-to-round plug style trainer cords are available.
- Neck strap - a neck strap may be connected to your T18MZ-WC system to make it easier to handle and improve your flying precision since your hands won't need to support the transmitter's weight.
- Y-harnesses, servo extensions, etc - Genuine Futaba extensions and Y-harnesses, including a heavy-duty version with heavier wire, are available to aid in your larger model and other installations.
- Gyros - a variety of genuine Futaba gyros are available for your aircraft or helicopter needs.
- Governor - for helicopter use. Automatically adjusts throttle servo position to maintain a constant head speed regardless of blade pitch, load, weather, etc.
- Receivers - various models of Futaba receivers may be purchased for use in other models. (Receivers for 2.4GHz types are available.)
- Servos - there are various kinds of servos. Please choose the Futaba servos that are suited to the model and its purpose. If you utilize a S.BUS system, you should choose a S.BUS servo. An analog servo cannot be used if "FASSTest12CH mode" is used.
- Telemetry sensor - please purchase an optional sensor, in order to utilize bidirectional communication system and to acquire the information from a model high up in the sky.
 - [Temperature sensor : SBS-01T/TE]
 - [Altitude sensor : SBS-01/02A]
 - [RPM sensor magnet type : SBS-01RM]
 - [RPM sensor optical type : SBS-01RO]
 - [RPM sensor brushless motor type : SBS-01RB]
 - [GPS sensor : SBS-01G]
 - [Voltage sensor : SBS-01V]
 - [Current sensor : SBS-01C]
 - [S.BUS servo sensor : SBS-01S]

Transmitter controls

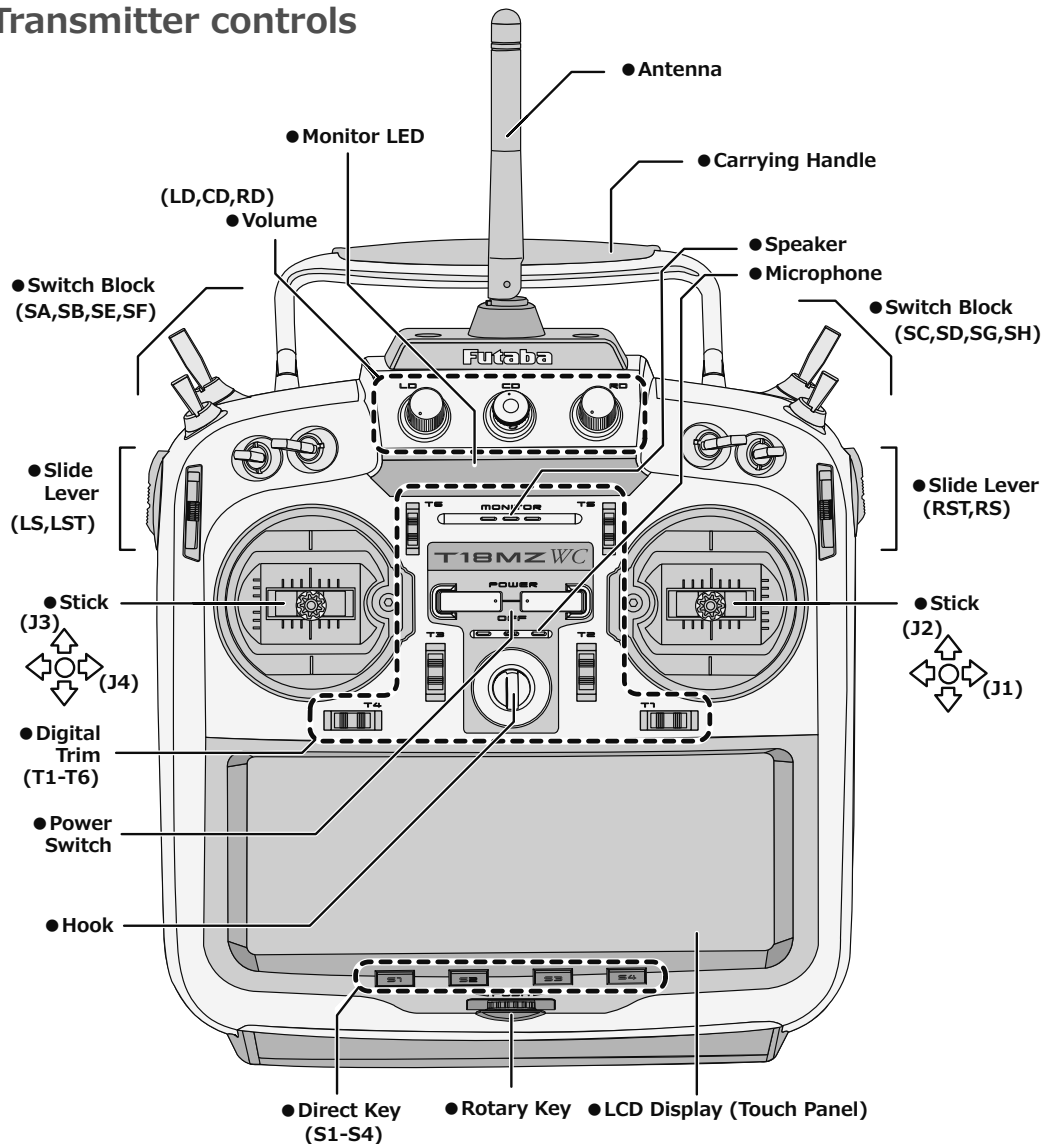

Cautions on handling antenna

⚠ WARNING

- ⊘ Do not touch the antenna during operation.
*There is the danger of erroneous operation causing a crash.
- ⊘ Do not carry the transmitter by the antenna.
*There is the danger that the antenna wire will break and operation will become impossible.
- ⊘ Do not pull the antenna forcefully.
*There is the danger that the antenna wire will break and operation will become impossible.

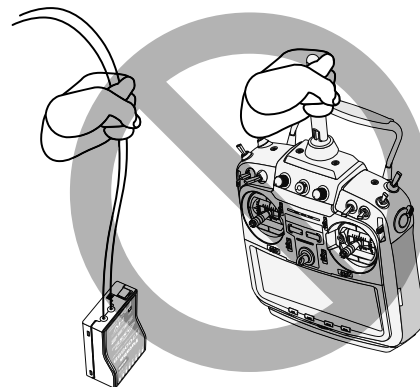

•Rotating antenna

The antenna can be rotated 90 degrees and angled 90 degrees. Forcing the antenna further than this can damage it. The antenna is not removable.

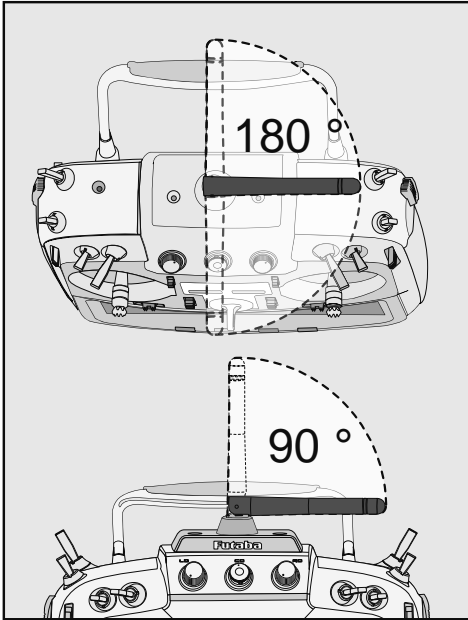

•Angle adjustment of the antenna

The antenna rotation and angle can be adjusted. The antenna features weak radio waves in the forward direction and strong radio waves in the sideways directions. Adjust the antenna angle to match your flying style.

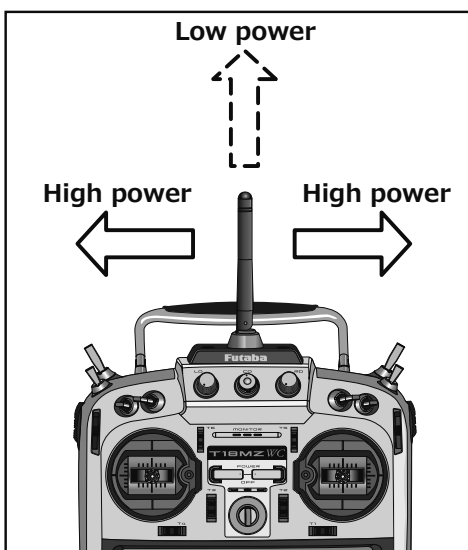

LED monitor

The status of the transmitter is displayed by changing the “MONITOR” section LED.

(LED Display)

FASSTest mode	Light Blue light
FASST mode	Green light
S-FHSS/T-FHSS mode	yellow-green light
RF-OFF	Violet light
Starting	Red light
Trainer Student	Blue light

Switch reallocation

You can reallocate the toggle switches on the shoulders of the transmitter, as you like.

(Default settings)

- SA : 3 positions; Alternate; Short lever
- SB : 3 positions; Alternate; Long lever
- SC : 3 positions; Alternate; Long lever
- SD : 3 positions; Alternate; Short lever
- SE : 3 positions; Alternate; Short lever
- SF : 2 positions; Alternate; Long lever
- SG : 2 positions; Alternate; Short lever
- SH : 2 positions; Momentary; Long lever

*You can choose the Switch and the On/Off position in the Switch Selection menu of your mix.

•When you change switches:

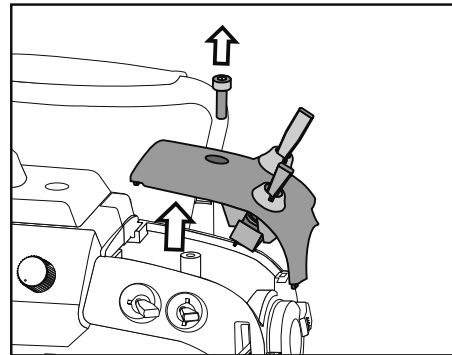

To relocate switches;

1. Make sure your transmitter is off, and use the attached 2.5mm hexagonal wrench (included) to turn the screw counter-clockwise on the switch block and detach the block. Remove the screw holding the switch block. Pull up on the switch block to remove it.
2. Disconnect the connectors of switches you want to change.
3. Use the attached jig (inside stylus) to turn the

face nuts counterclockwise, this will detach the switches.

4. To re-attach, use the face nuts to attach switches from other positions or optional switches to the switch block.
5. Connect your connectors.
6. Insert the switch block so reconnect the connectors that it fits correctly into the body of the transmitter (as shown in the picture) and use the hexagonal wrench to tighten the screws.

Volume

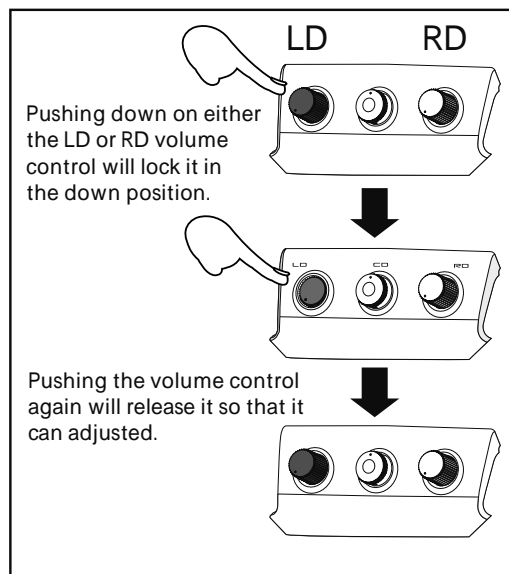

Volume LD, CD, and RD:

If you push the volume button in, it will be locked in place. To release the volume button, push it in lightly once more.

This volume is digital type (rotary encoder).

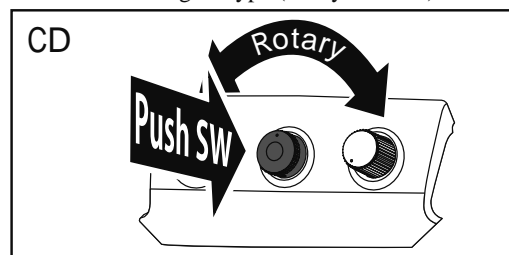

"CD" volume works as both a volume and a push-switch.

- *T18MZ-WC beeps when the volume knob reaches center.
- *You can check the volume position on the Dial Monitor screen in the Linkage menu.
- *You can use each setting screen of the mixing functions to select volumes and define the direction of its movement.

Slide Lever

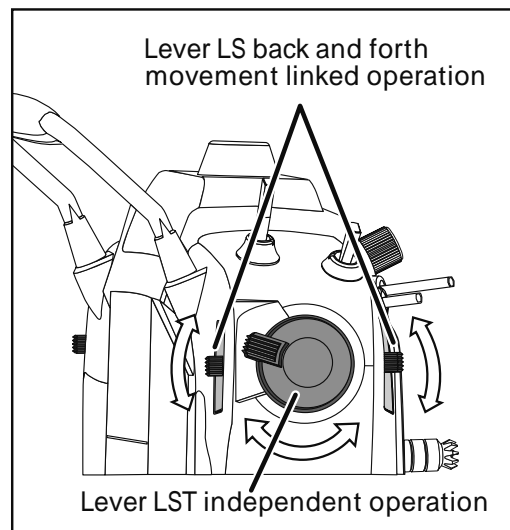

LST (Left), RST (Right):

Outside levers

LS (Left), RS (Right):

Inside levers: Each lever has two ends, one at the front and the other at the back of the transmitter.

- *It will beep when the lever is set to the center.
- *You can check the lever position on the dial-monitor screen in the linkage menu.
- *You can select a slide lever and set the movement direction on the setting screen of mixing functions.

Digital trim

This transmitter is equipped with digital trims. Each time you press a trim button, the trim position moves one step. If you continue pressing it, the trim position starts to move faster. In addition, when the trim position returns to the center, the tone will change. You can always monitor trim positions graphics on the screen. To change the trim rate, you must activate this through the function menu, within the linkage menu. Touch the trim button and you will access another screen which enables you to change the trim percentages.

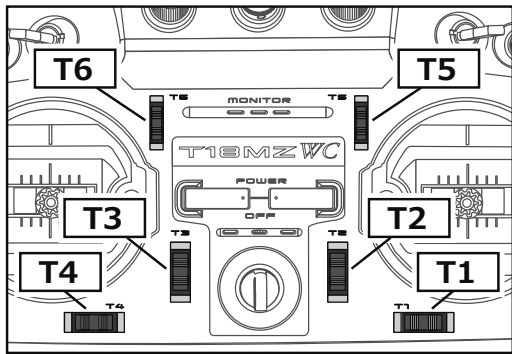

Note: The trim positions you have set will be stored in the non-volatile memory and will remain there.

Touch Panel/ Rotary Key/ Direct Key

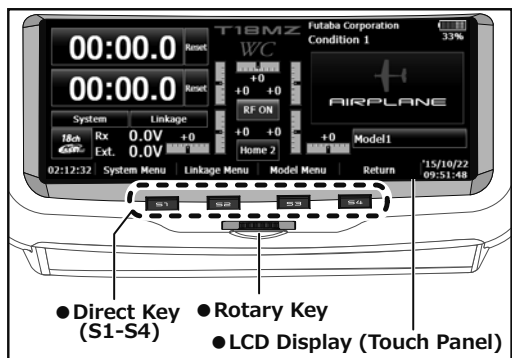

Touch panel, rotary keys and direct keys are used for entering data.

Touch Panel

Touch the panel with your finger or the attached stylus pen, which is also used as a toolbox, to enter data.

⚠ CAUTION

- ❗ Touch softly the Touch Panel with the stylus pen or your fingertips.

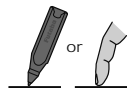

*Plastic film is attached to the touch panel. Please be careful so that you don't scratch the touch panel with anything hard such as a metal object. Don't push the touch panel with excessive force or drop anything on the panel.

*Although you may find some air bubbles under the plastic panel due to environmental changes such as temperature, it is not a defect and will cause no problems.

*Color LED is made from many pixels. Some pixels hold lighting. Moreover, some pixels go out. And a screen may flicker. Such condition is the characteristics of color LED. It is not failure.

Rotary key

In addition to touch panel, you can select items by rotating the rotary keys to the left or to the right.

*There is a function which cannot be accessed by the Rotary Key.

Direct key

You can directly call your favorite functions or menu screens.

(The default setting at the factory)

- S1: System menu
- S2: Linkage menu
- S3: Model menu
- S4: Return

[How to change assignment of the direct key]

1. Open the screen you want to call. Then push S1 and S4 keys simultaneously. (You will see the direct key setting screen.)
2. Select the direct key.
3. Press the [Enter] key.
4. Press the [Yes] key.

Touch Panel (and Rotary Key) lock

Please perform a touch-panel lock for safety. Touch screen in [System Menu] [Display] other than the following has an automatic setup.

Start-up lock: It becomes a panel lock at the time of the power supply ON.

Automatic lock: It synchronizes with Backlight decrease time and becomes a panel lock.



The touch panel locked by S2 and S3 pushed.

The touch panel unlocked by S2 and S3 pushed again.

Locking the LCD touch screen.

⚠ DANGER

- ❗ The T18MZ-WC's touch screen is very sensitive. To avoid accidentally activating it during a flight, it is suggested that it be locked. Due to the touch screen's sensitivity, allowing it to be touched during flight by a neck strap hook, servo extension, or even your hand could be dangerous. Please use the touch panel lock for added safety during flight.

Stick Adjustment

Adjustment of the stick lever angle

You can make fine adjustments to the angle of a stick lever either inwards or outwards from the center stick position.

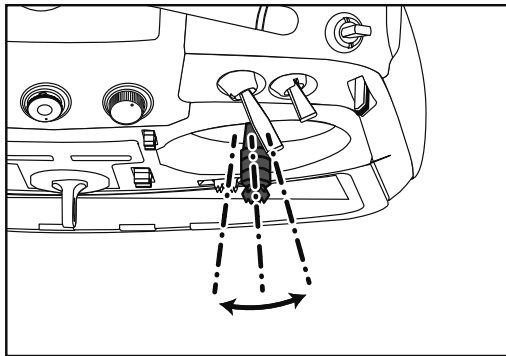
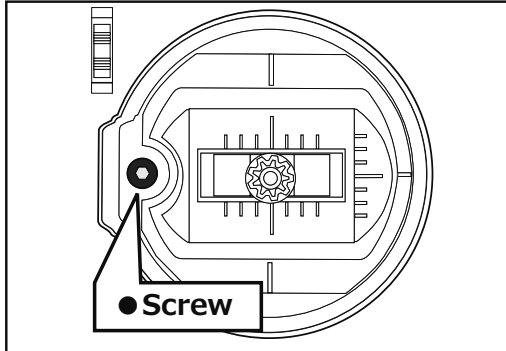

Use the attached 1.5mm hexagonal wrench (inside stylus) to turn the screw clockwise to adjust the stick outwards, or counter-clockwise to tilt it inward.

Note: Be careful not to turn the screw too far counterclockwise as it could fall out.

Adjustment of the lever length

You can adjust the length of stick levers, if you like. It is recommended to adjust the length of the sticks in line with your hand size.

[How to adjust the Stick length.]

1. Hold the lever head "B" and turn the lever head "A" counter-clockwise, the lock will be released.
2. Adjust the stick lever to the desired length by turning lever head A.

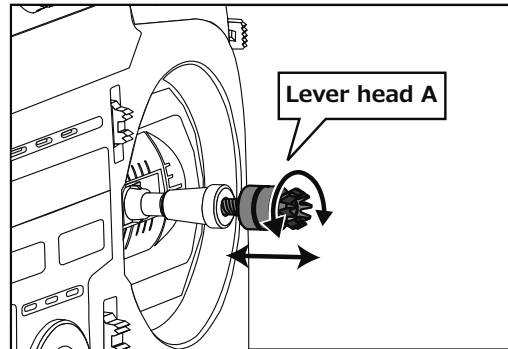

3. Securely lock the stick lever by holding lever head A and turning lever head B counterclockwise.

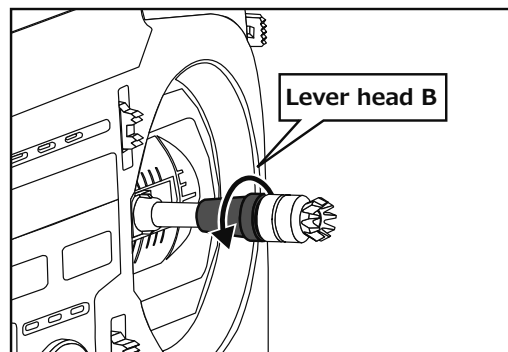

Adjustment of Stick Lever Tension

You can adjust the tension of stick-levers.

The rubber cover in the back is removed first.

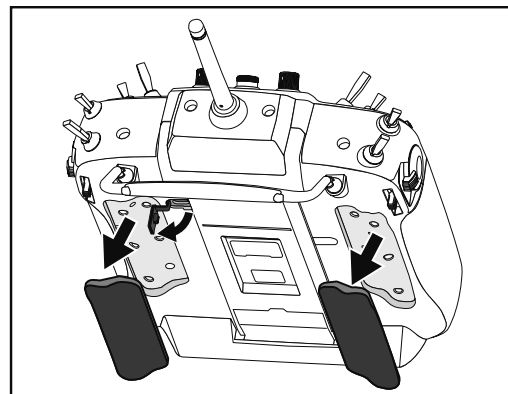

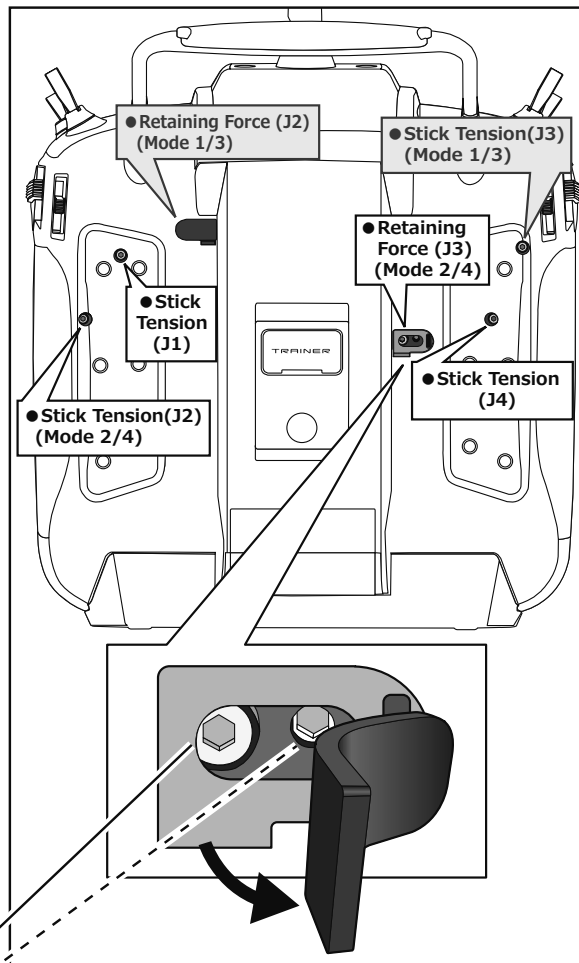

*In the Mode 1/3, arrangement of a screw is opposite.

[Adjustment of tension]

Adjustment of Throttle Stick (Ratchet System)

You can choose either airplane ratchet system or helicopter-touch.

1. Open the dust protection cap on the back of the transmitter that is covering the hole for throttle stick adjustment.
2. Use the attached 1.5mm hexagonal wrench (inside stylus) to turn the adjustment screw and set it as you prefer. Turning the screw clockwise increases the tension.

For airplanes: Adjust the screw on the left.

For helicopters: Adjust the screw on the right.

In changing the setting from airplane to helicopter (or heli to airplane);

1. Turn the screw counter-clockwise until the throttle stick moves freely, and turn the screw clockwise to adjust it to the tension you prefer.

*This transmitter has two ratchet plates, one for airplane and the other one for helicopter. If you tighten both screws, you won't be able to achieve the adjustment that you need because of the overlap of those two adjustments.

*If you want to change the setting from airplane to helicopter (or from helicopter to airplane), turn the ratchet screw clockwise until the throttle stick moves freely. Then turn the screw for the helicopter until you get the tension you like.

Battery exchange

Note: Detaching the battery while the power is on can cause data you have recently edited to be lost.

[How to remove battery LT2F3500XH]

1. Using the tabs at the side of the transmitter, open the side door to the rear as shown in the figure.

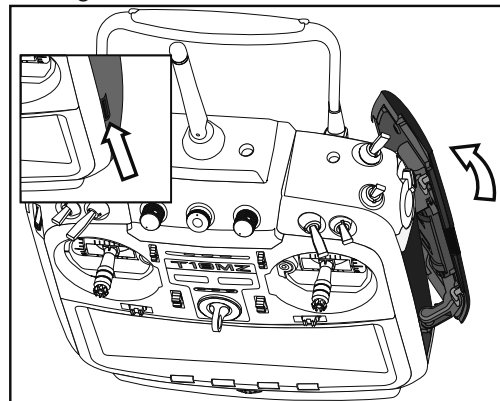

2. Open the battery cover inside the transmitter by sliding it upward as shown in the figure.

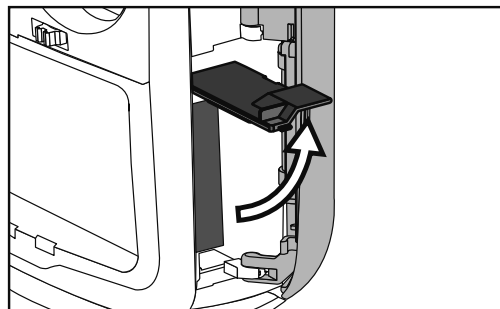
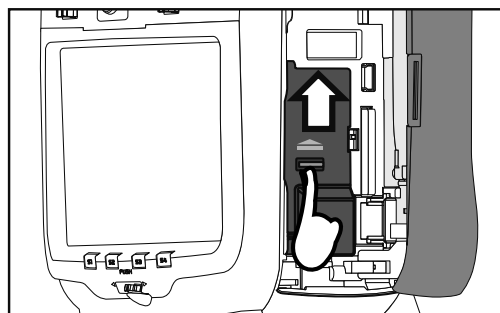

3. Pull up on the lip of the black "connector slider" to remove the battery connector.

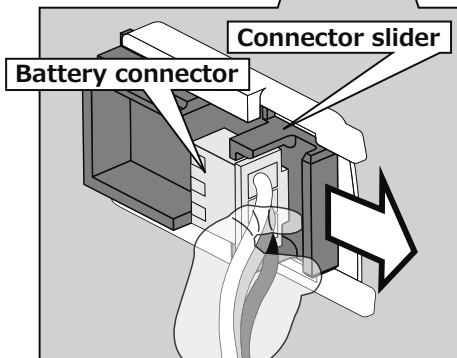
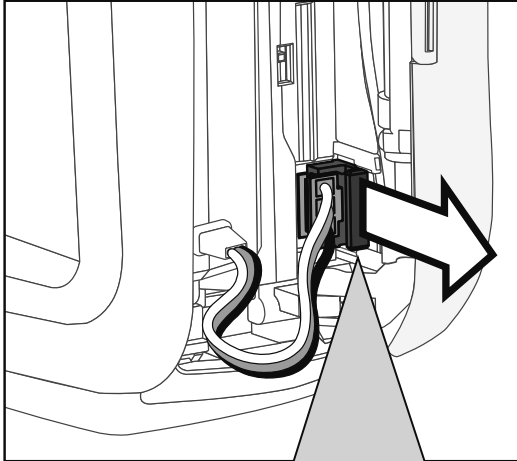

*Remove the connector by pulling up on the lip of the slider, not the wiring.

4. Pull out the battery.

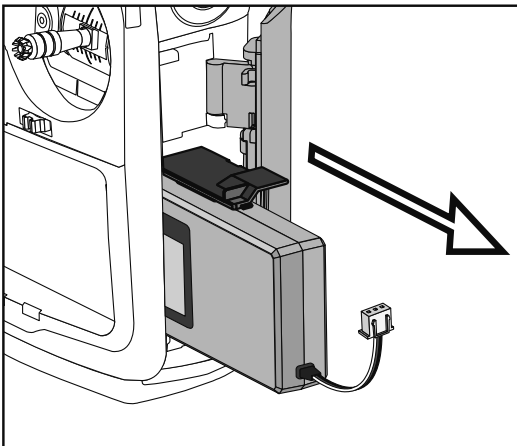

*As for T18MZ-WC, the battery connector is not connected at first.
Please connect a battery connector, as shown in a figure.

[How to install battery LT2F3500XH]

1. Insert the battery into the transmitter.

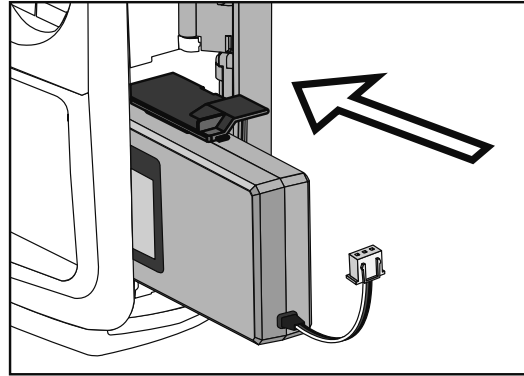

2. Insert the battery with the battery connector facing the direction shown in the figure. (Push the battery housing, not the battery wiring.)

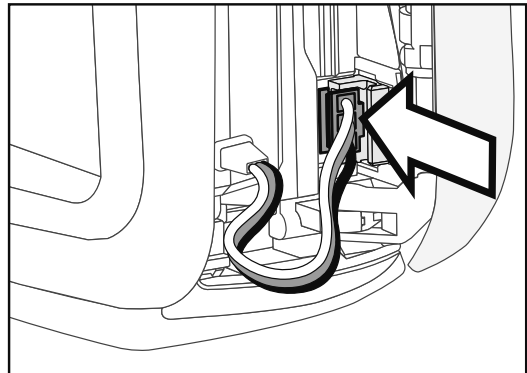

3. Arrange the battery wiring as shown in the figure.

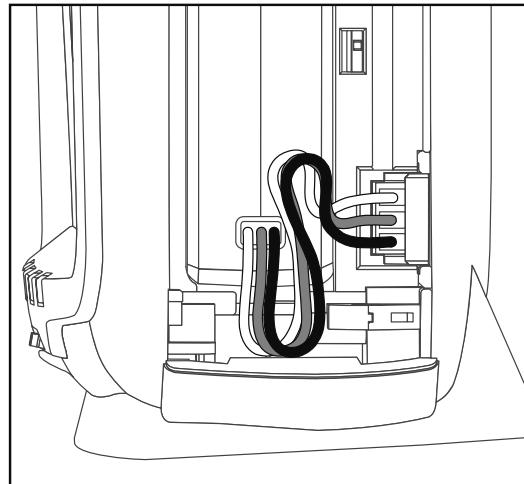

4. Close the battery cover so that the wiring is not pinched and lock the cover by pushing downward.

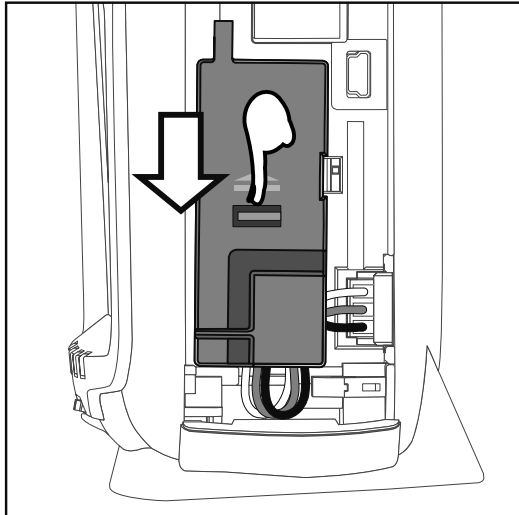

5. Close the side door.

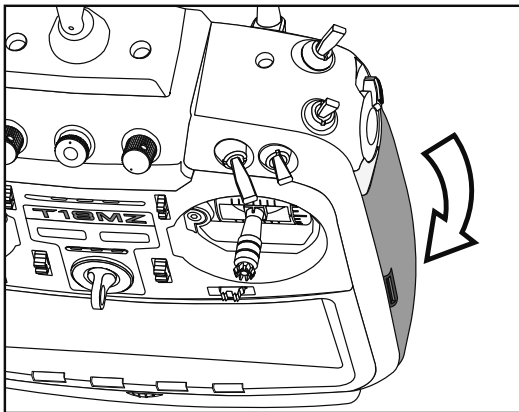

⚠ WARNING

- ❗ Be careful to not drop the battery.
- ⊘ Never take out the battery from the T18MZ-WC transmitter while the LED monitor is blinking.
 - * Internal settings and memories can be destroyed.
 - * Do not use the transmitter if a "Backup Error" warning occurs. Send it to the Futaba Service Center to be checked.
- ⊘ Don't pull battery wiring.
 - *When it short-circuits, there is danger of explosion ignition.

Back lid

The charging connector, earphone jack, S.BUS setting connector and charge LED are accessed by opening the transmitter rear cover as shown in the figure.

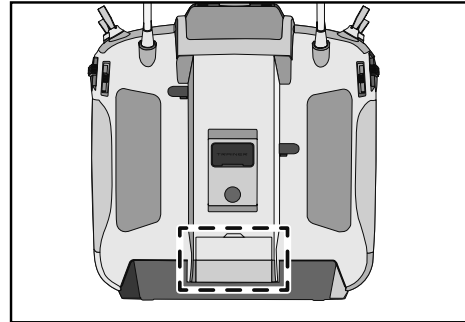

[How to open back lid.]

1. Open the transmitter rear cover as shown in the figure.

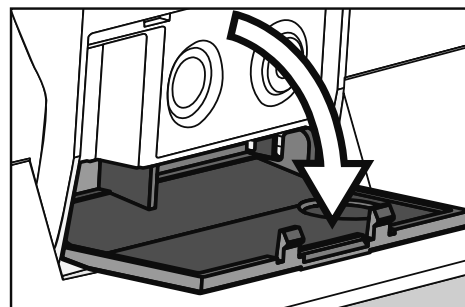
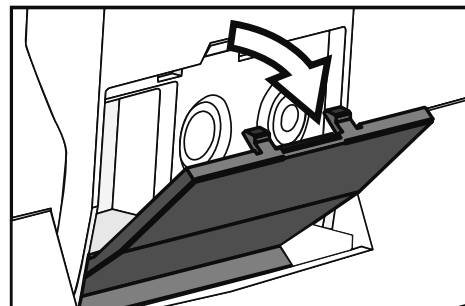

2. House the rear cover by pushing it into the transmitter.

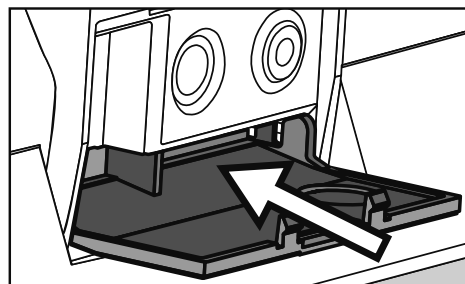

Charge LED **S.BUS setting connector**

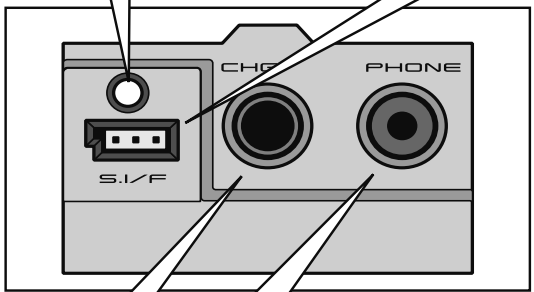

Charge plug **Audio plug (PHONE)**

3. When not using the connector, pull out and close the rear cover.

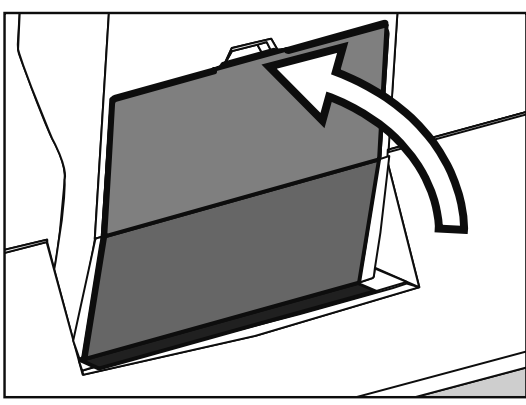
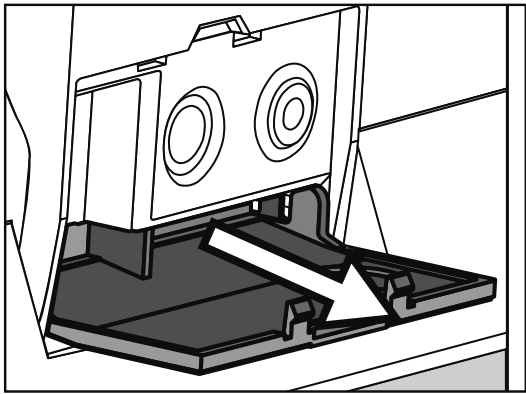

Connector/Plug

1. The back of transmitter.

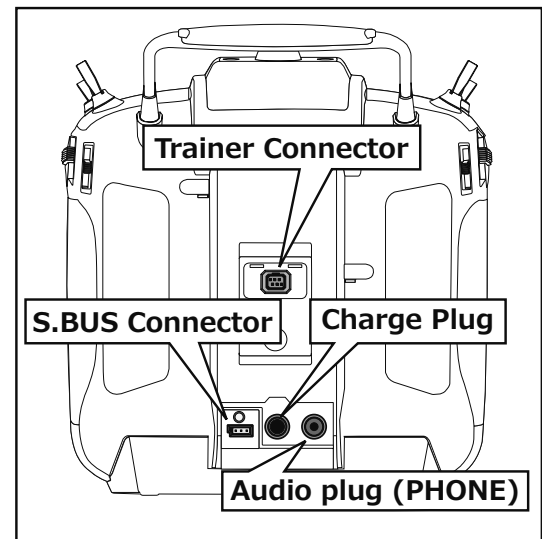

2. Inside of transmitter of side cover

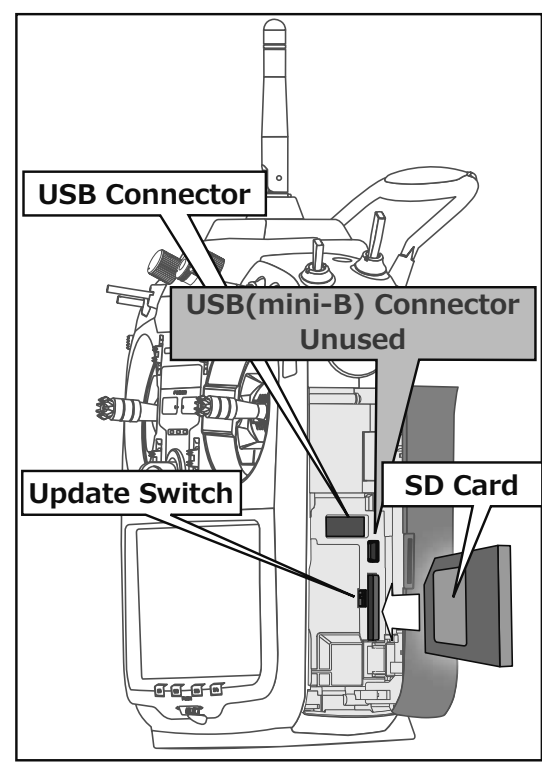



SD Card (sold separately)

The SD card can store various files, such as model data, music, sound files and pictures. Any SD card on the market can be used with the T18MZ-WC. The card is locked when it is pushed in all the way in. To remove the card, push in on the card again, it will pop up allowing you to remove it.

*Write protection of SD card is turned OFF. In the state of protection, model data cannot be saved on SD card.

WARNING

 Be sure to turn off the power to the transmitter before inserting or removing the SD card.

 As the SD card is a precision device, do not use excessive force when inserting.

 If model data generated by a new software version transmitter is copied to an old software version transmitter, the transmitter may operate erroneously. Copy the model data after updating the copy destination transmitter to the new software version.

Read data from a PC

Saving music and image files edited by a PC into the SD card, you can use those files on your T18MZ-WC transmitter. Equipment for reading and writing SD cards are available at most electronics stores.

Stored data

The life of the SD card is limited due to the use of flash memory. If you have a problem saving or reading data such as picture data after a long period of use you may need to purchase a new SD card.

*We are not responsible for, and cannot compensate for any failure to the data stored in the memory card for any reason. Be sure to keep a backup of your models and data in your SD card.

***No need for backup battery;** T18MZ-WC transmitters and SD cards are using nonvolatile memory devices so that the data stored in those will not be destroyed even without a backup battery. The clock for the transmitter depends on the Lithium battery.

Update Switch

When using an SD card to update the T18MZ-WC software, set this switch to the up position. Then input the software to be updated to the SD card from the Futaba importers homepage and update the software in accordance with the updating procedure.

USB port

The following functions can be used with USB connector.

- USB Mouse
When a mouse is connected, a cursor will appear on the screen and the mouse can be used instead of the touch panel.
- USB Keyboard
When a keyboard is connected, the model name and other data can be input by keyboard.
- USB Memory
All model data, etc. can be saved to an optional USB Memory stick.

Connector for trainer function (TRAINER)

When you use trainer function, connect the optional trainer cable between the transmitters for teacher and student.

*You can set the trainer function on the Trainer Function screen in the system menu

Connector for DSC function (DSC)

You can operate the transmitter without transmitting radio waves by connecting the transmitter and the receiver to the DSC cable.

*Please refer to the section "Connection between Receiver/Servo"

S.BUS connector (S.I/F)

When setting an S.BUS servo and telemetry sensor, connect them both here.

(Supply power by 3-way hub or 2-way cord.)

Audio plug (PHONE)

Connecting a stereo headphone to this plug, you can enjoy music files stored in the SD card.

Connector for battery charger (CHG)

You cannot use the charger that was included with the transmitter, without using the AC adapter that comes with this.

DANGER

 Do not connect any other chargers. The charger for the receiver battery cannot be used for the transmitter.

USB port (mini-B)

*This is for factory use only.

Camera function

This transmitter has a digital camera function. A picture of your favorite model and other pictures (0.03M megapixels) can be allocated to transmitter model data.

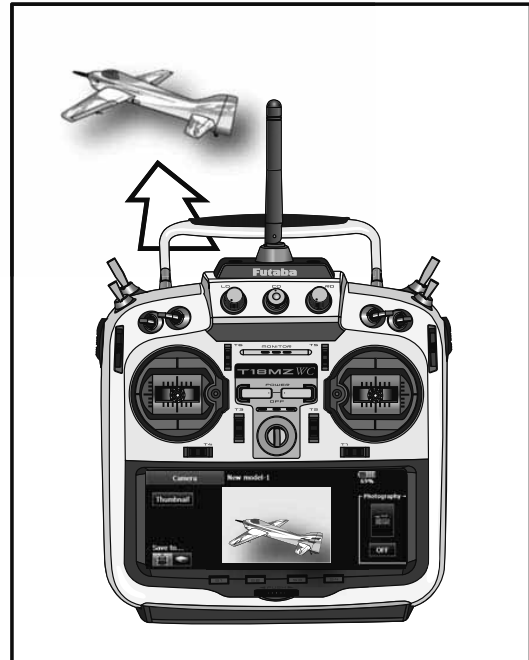
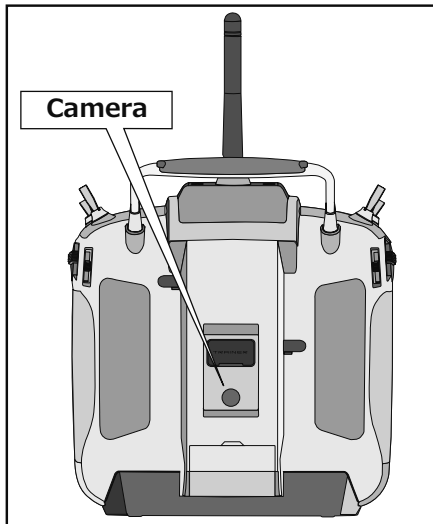

⚠ WARNING

⊘ Do not use the camera function during flight and when starting the engine.

*It is dangerous to look away from or have your model out of your line of sight while flying.

Receiver nomenclature

Before using the receiver, be sure to read the precautions listed in the following pages.

Receiver R7008SB

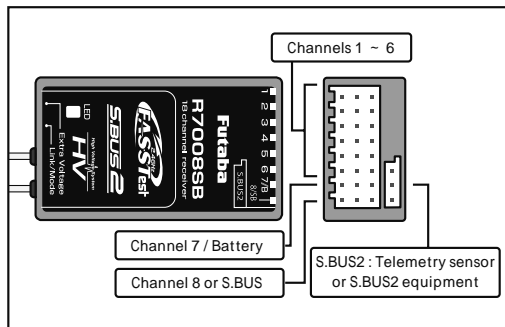

Connector

"1 through 6": outputs for the channels 1 through 6

"7/B": outputs of 7 channels and power.

"8/SB": outputs of 8 channels or S.BUS port.

[S.BUS Sevo S.BUS Gyro] →

"S.BUS2": outputs of S.BUS2 port.

[Telemetry Sensor] →

*When using 9 or more channels, use an S.Bus function or use a second R7008SB and link both to your transmitter.

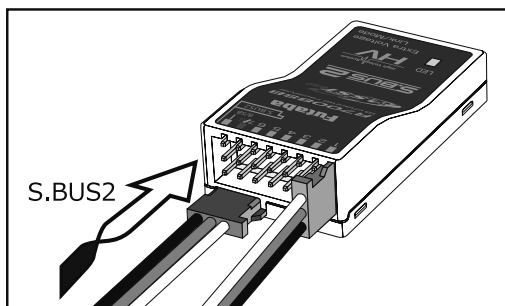

Connector insertion

Firmly insert the connector in the direction shown in the figure. Insert the S.BUS2 by turning it 90 degrees.

⚠ WARNING

S.BUS2 connectors

❗ Don't connect an S.BUS servo / gyro to BUS2 connector.

LED Monitor

This monitor is used to check the CH mode of the receiver.

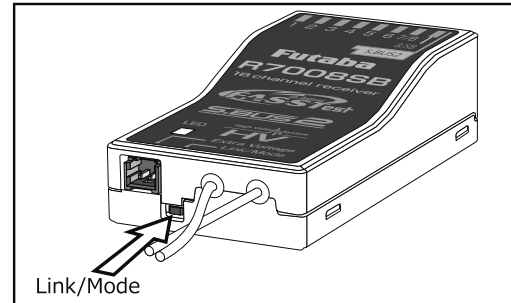

Link/Mode Switch

Use the small plastic screw driver that was included with your receiver.

The Link/Mode Switch is also used for the CH mode selection.

(The button is not used to link the transmitter and receiver together.)

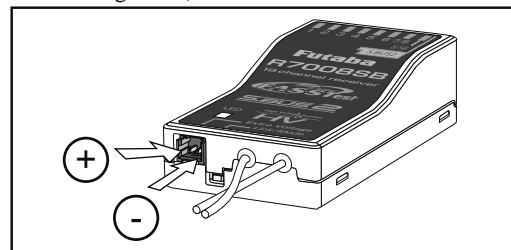

Extra Voltage Connector

Use this connector when using a voltage telemetry device to send the battery voltage (DC0 ~ 70V) from the receiver to the transmitter.

Please use an option is External voltage input cable. Wire in an extra connector to you drive batteries that mates with the extra voltage connector.

⚠ DANGER

⊘ Don't touch wiring.

* There is a danger of receiving an electric shock.

⊘ Do not short-circuit the battery terminals.

* A short circuit across the battery terminals may cause abnormal heating, fire and burns.

⊘ Please double check your polarity (+ and -) when hooking up your connectors.

* If + and - of wiring are mistaken, it will damage, ignite and explode.

⊘ Don't connection to Extra Voltage before turning on a receiver power supply.

Connection of a receiver battery

⚠ WARNING

- ⊘ Please make sure that you use a battery that can deliver enough capacity for the number and kind of servos used. Alkaline (Dry) batteries cannot be used.

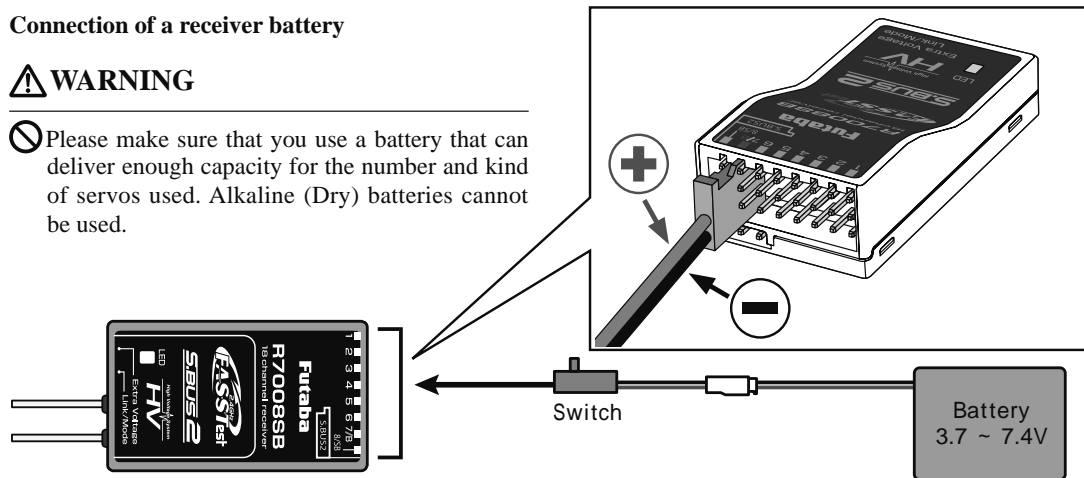

A battery is connectable also with which port.

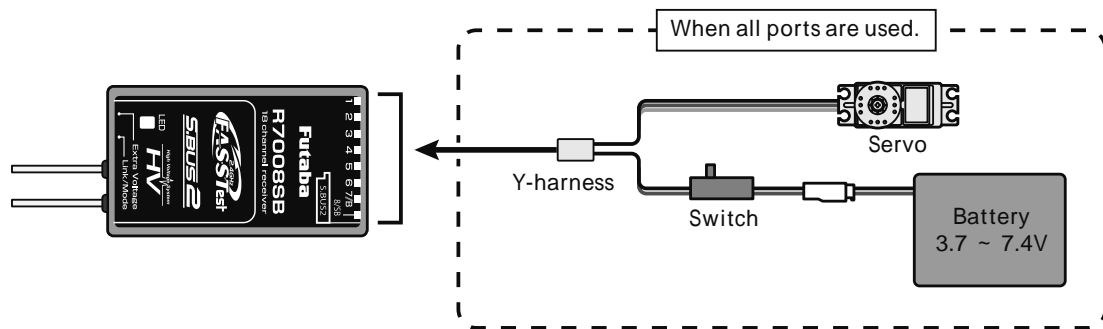

Connection example

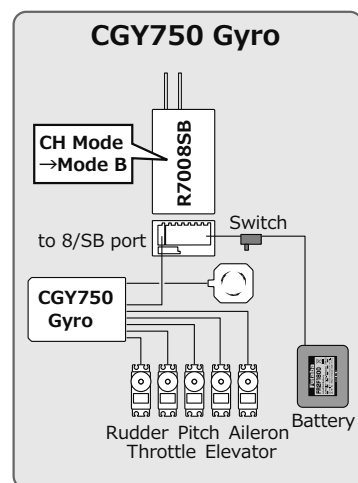
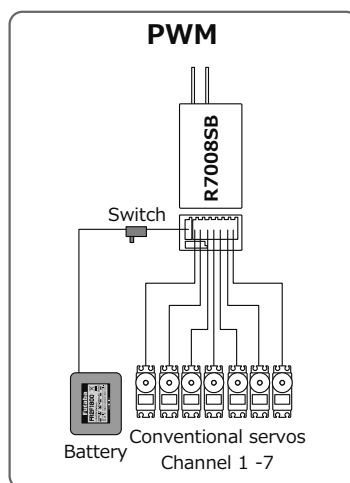
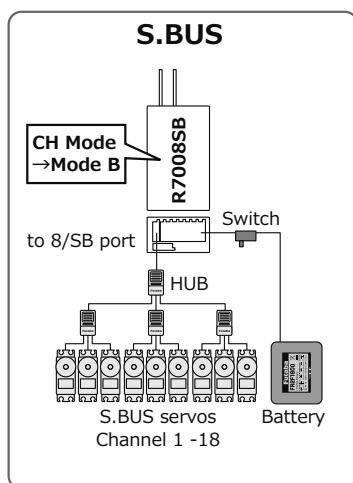

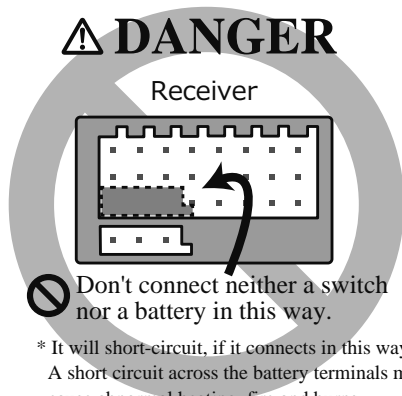

⊘ Don't connect neither a switch nor a battery in this way.

* It will short-circuit, if it connects in this way.
A short circuit across the battery terminals may cause abnormal heating, fire and burns.

R7008SB CH Mode

The R7008SB receiver is a very versatile unit. It has 8 PWM outputs, S.BUS and S.BUS2 outputs. Additionally the PWM outputs can be changed from channels 1-8 to channels 9-16. If you only desire to use it as an 8 channel receiver (without S.BUS), it can be used without any setting changes.

The T18MZ-WC has the ability to link to two R7008SB receivers - one of them outputting channels 1-8 and the other outputting channels 9-16, giving you 16 PWM channels. Instructions for this configuration and S.BUS operation follow.

[How to change the R7008SB Channel mode.]

1. Press and hold down the Link/Mode button on the R7008SB receiver.
2. Turn the receiver on while holding down the Link/Mode button. When the LED begins to blink green/red the button may be released.
3. The LED should now be blinking red in one of the patterns described by the chart below.
4. Each press of the Mode/Link button advances the receiver to the next mode.
5. When you reach the mode that you wish to operate in, press and hold the Mode/Link button for more than 2 seconds.
6. Once locked into the correct mode the LED will change to a solid color.
7. Please cycle the receiver(s) power off and back on again after changing the Channel Mode.

R7008SB CH MODE TABLE

Receiver connector	Setting channel			
	Mode A 1 ~ 8CH	Mode B 1 ~ 7CH	Mode C 9 ~ 16CH	Mode D 9 ~ 15CH
1	1	1	9	9
2	2	2	10	10
3	3	3	11	11
4	4	4	12	12
5	5	5	13	13
6	6	6	14	14
7/B	7	7	15	15
8/SB	8	S.BUS	16	S.BUS
Red LED blink	1 time	2 times	3 times	4 times

⊘ Default

Servo (Option) · Toolbox

Servo (Option)

Purchase servos appropriate for their intended use.

*Analog servos may not be used when operating in the FASSTest 12CH mode.

When operating in the FASSTest12CH mode use **digital servos**, this includes all **brushless** and **S.Bus servos**.

Toolbox

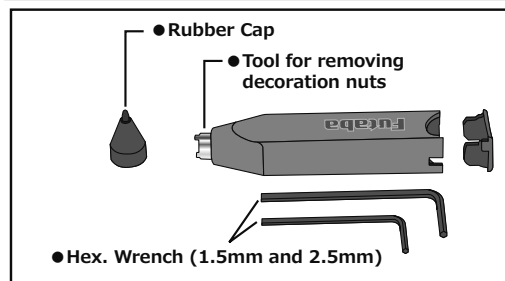

A special toolbox is included with your T18MZ-WC. This allows you to make all of the mechanical adjustments that may be needed.

Hexagonal wrench (1.5mm and 2.5mm)

These wrenches are for adjustment of sticks and replacement of the switches.

Tool for removing switch nuts.

This is used when changing or replacing switches.

Stylus pen

A rubber cap is attached to the stylus pen/toolbox. You may use this stylus with rubber cap when operating the touch panel. The stylus allows more precise operation than fingers without fear of damaging the panels surface.

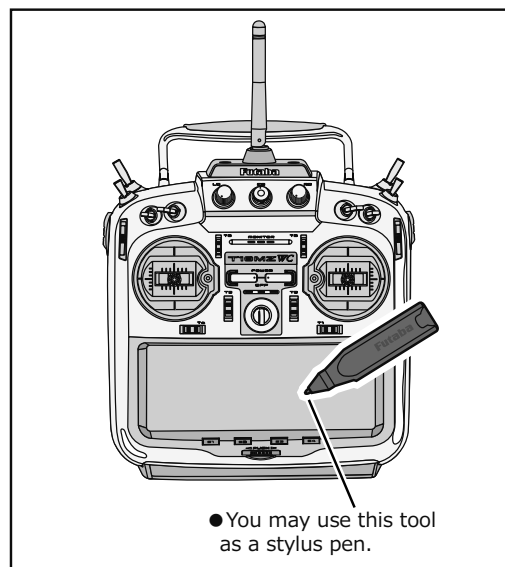

Receiver's Antenna Installation

The R7008SB has two antennas. In order to maximize signal reception and promote safe modeling Futaba has adopted a diversity antenna system. This allows the receiver to obtain RF signals on both antennas and fly problem-free.

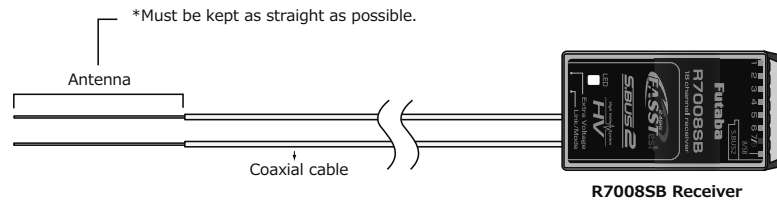

To obtain the best results of the diversity function, please refer to the following instructions:

1. The two antennas must be kept as straight as possible. Otherwise it will reduce the effective range.
2. The two antennas should be placed at 90 degrees to each other.

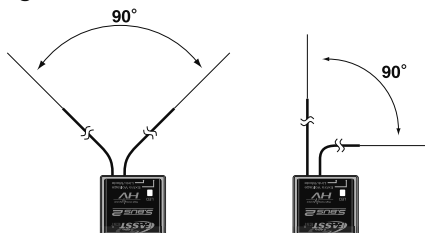

This is not a critical figure, but the most important thing is to keep the antennas away from each other as much as possible.

Larger models can have large metal objects that can attenuate the RF signal. In this case the antennas should be placed at both sides of the model. Then the best RF signal condition is obtained at any flying attitude.

3. The antennas must be kept away from conductive materials, such as metal, carbon and fuel tank by at least a half inch. The coaxial part of the antennas does not need to follow these guidelines, but do not bend it in a tight radius.
4. Keep the antennas away from the motor, ESC, and other noise sources as much as possible.

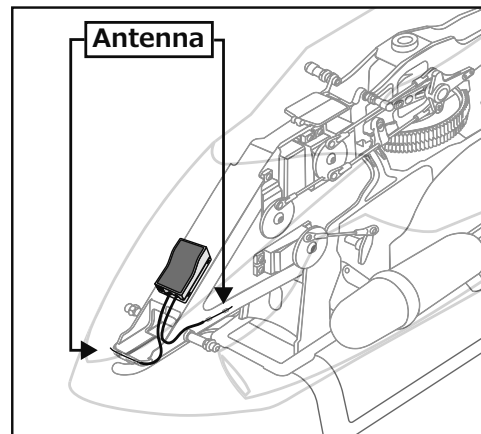
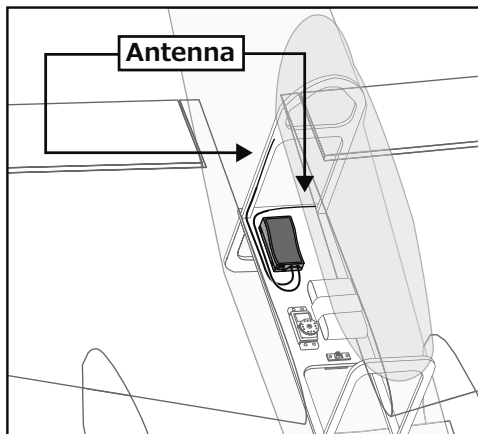

*The two antennas should be placed at 90 degrees to each other.

*The Illustration demonstrates how the antenna should be placed.

*Receiver Vibration and Waterproofing: The receiver contains precision electronic parts. Be sure to avoid vibration, shock, and temperature extremes. For protection, wrap the receiver in foam rubber or other vibration-absorbing materials. It is also a good idea to waterproof the receiver by placing it in a plastic bag and securing the open end of the bag with a rubber band before wrapping it with foam rubber. If you accidentally get moisture or fuel inside the receiver, you may experience intermittent operation or a crash. If in doubt, return the receiver to our service center for service.

Mounting the Servo

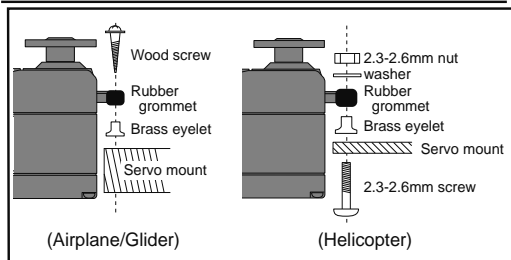

Servo lead wires

To prevent the servo lead cable from being broken by vibration during flight, provide a little slack in the cable and fasten it at suitable points. Periodically check the cable during daily maintenance.

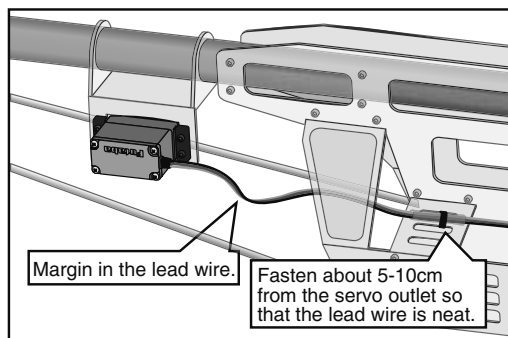

Mounting the power switch

When mounting a power switch to an airframe, make a rectangular hole that is a little larger than the total stroke of the switch so that you can turn the switch ON/OFF without binding.

Avoid mounting the switch where it can be covered by engine oil and dust. In general, it is recommended to mount the power switch on the side of the fuselage that is opposite the muffler.

Safety precautions when you install receiver and servos

⚠ WARNING

Connecting connectors

- ❗ Be sure to insert the connector until it stops at the deepest point.

How to protect the receiver from vibration and water

- ❗ Wrap the receiver with something soft such as foam rubber to avoid vibration. If there is a chance of it getting wet, put the receiver in a waterproof bag or balloon to avoid water.

Receiver's antenna

- ⊘ Never cut the receiver's antenna. Do not bind the receiver's antenna with the cables for servos.
- ❗ Locate the receiver's antenna as far as possible from metals or carbon fiber components such as frames, cables, etc.

*Cutting or binding the receiver's antenna will reduce the radio reception sensitivity and range, and may cause a crash.

Servo throw

- ❗ Adjust your system so that pushrods will not bind or sag when operating the servos to the full extent.

*If excessive force is continuously applied to a servo, the servo could be damaged due to force on the gear train and/or power consumption causing rapid battery drain.

Mounting servos

- ❗ Use a vibration-proof rubber (such as rubber grommet) under a servo when mounting the servo on a servo mount. And be sure that the servo cases do not touch directly to the metal parts such as servo mount.

*If the servo case contacts the airframe directly, vibration will travel to and possibly damage the servo.

S.BUS Installation

This set uses the S.BUS system. The wiring is as simplified and clean mounting as possible, even with models that use a large number of servos. In addition, the wings can be quickly installed to the fuselage without any erroneous wiring by the use of only one simple wire, even when there are a large number of servos used.

- When using S.BUS, special settings and mixes in your transmitter may be unnecessary.
- The S.BUS servos and S.BUS gyros memorize the number of channels themselves. (Settable with the T18MZ-WC)
- The S.BUS system and conventional system (receiver conventional CH used) can be mixed.

S.BUS Glider usage example

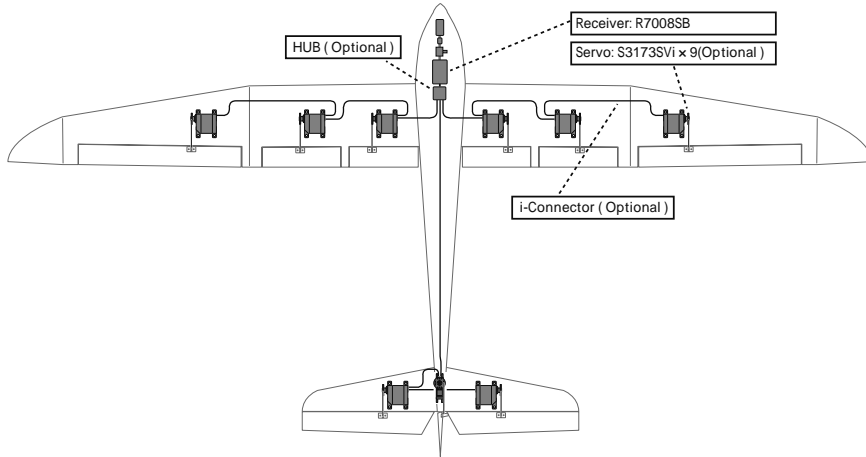

S.BUS Aerobatic plane usage example

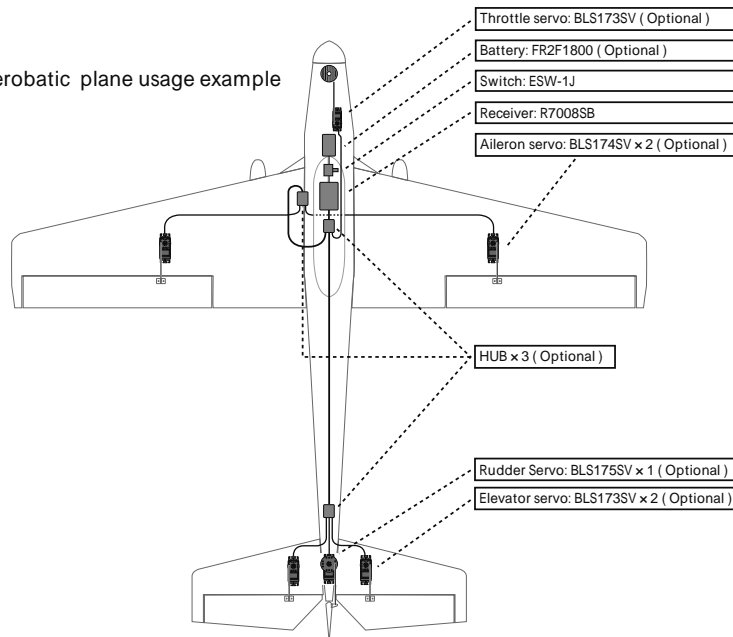

S.BUS Wiring example

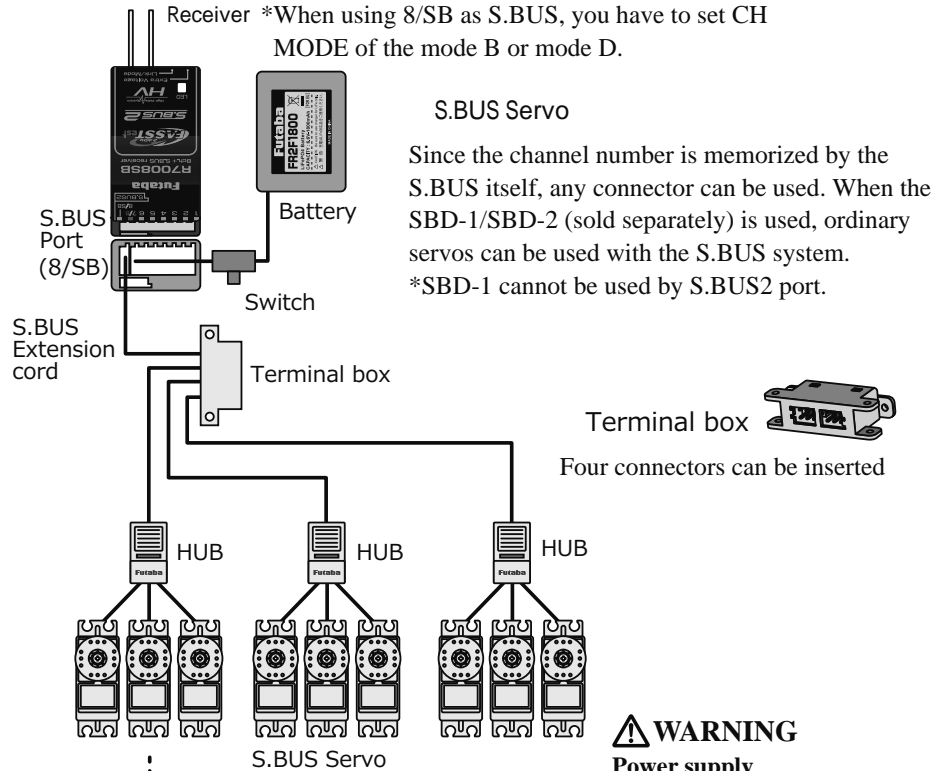

⚠ WARNING Power supply

❗ Please make sure that you use a battery that can deliver enough capacity for the number and kind of servos used. Alkaline batteries cannot be used.

When separate power supply used

When a large number of servos are used or when high current servos are used, the servos can be driven by a separate power supply by using a separate Power Supply 3-way Hub.

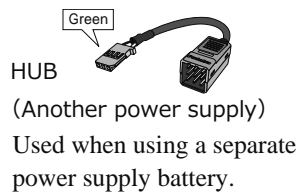
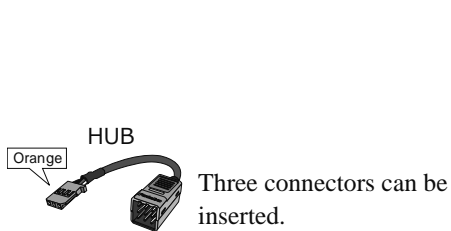

S.BUS2 System

When using the S.BUS2 port, an impressive array of telemetry sensors may be utilized.

S.BUS2 TABLE

Receiver port	S.BUS Servo S.BUS Gyro	S.BUS2 Servo S.BUS2 Gyro	Telemetry sensor
S.BUS			×
S.BUS2	× ()		

() Don't connect S.BUS Servo, S.BUS Gyro to S.BUS2 connector.

CH Mode is set to ModeB [D].

S.BUS servos and gyros and S.BUS2 servos and gyros must be used in the correct receiver ports. Please refer to the instruction manual to make sure you connect to the correct one.

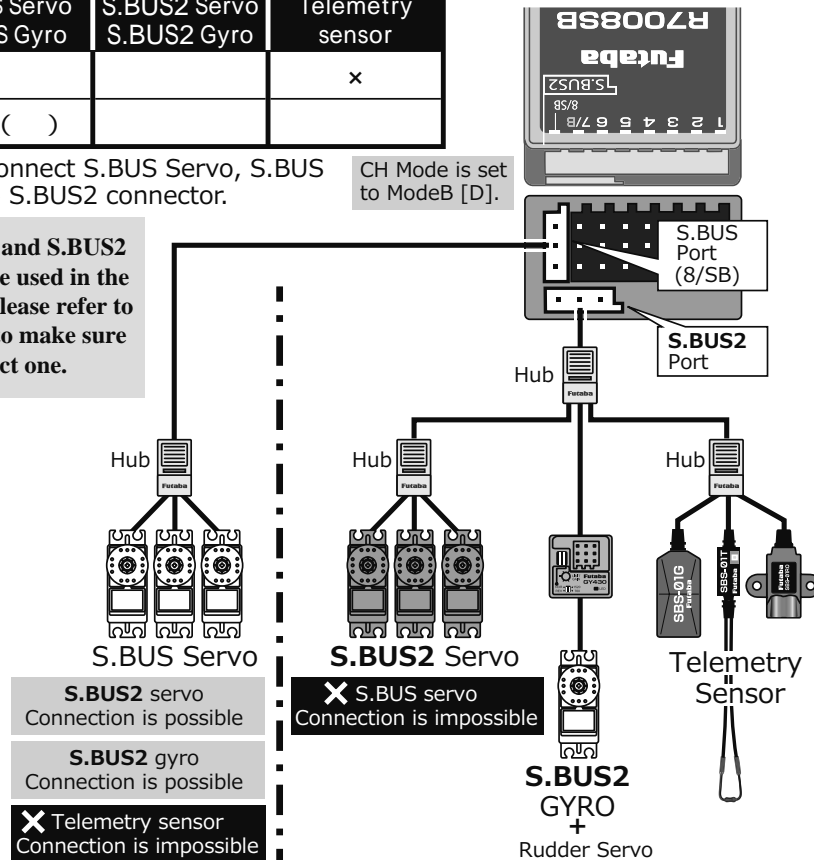

S.BUS device setting

S.BUS servos or a telemetry sensor can be connected directly to the T18MZ-WC. Channel setting and other data can be entered for the S.BUS servos or sensors.

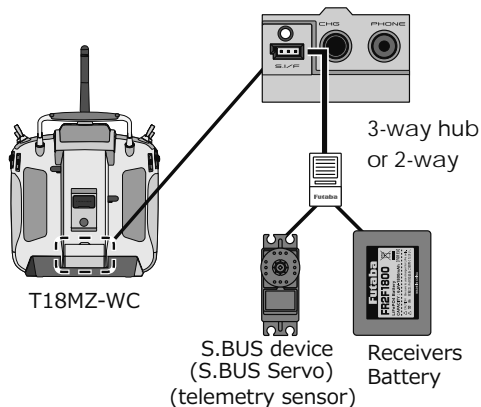

1. Connect the S.BUS device and battery you want to set with a 3-way hub or 2-way cord as shown in the figure.
2. Turn on the transmitter power.
3. Call the setup screen.
Servo: System Menu S.BUS Servo
Sensor: Linkage Menu Sensor
4. Perform setting in accordance with each screen.
5. This sets the channel and other data for each S.BUS servo, or telemetry device to be used with the S.BUS device or receiver.

Telemetry System

The R7008SB receiver features bi-directional communication with a FASSTest Futaba transmitter using the S.BUS2 port. Using the S.BUS2 port an impressive array of telemetry sensors may be utilized. It also includes both standard PWM output ports and S.BUS output ports.

*Telemetry is available only in the FASSTest 18CH/T-FHSS mode. (FASSTest 12CH mode displays only Receiver battery voltage and Extra battery voltage.)

*The telemetry function requires the corresponding receiver.

*Each receiver has its own unique guid (globally unique identifier) or ID code for the transmitter to remember and recognize when in use.

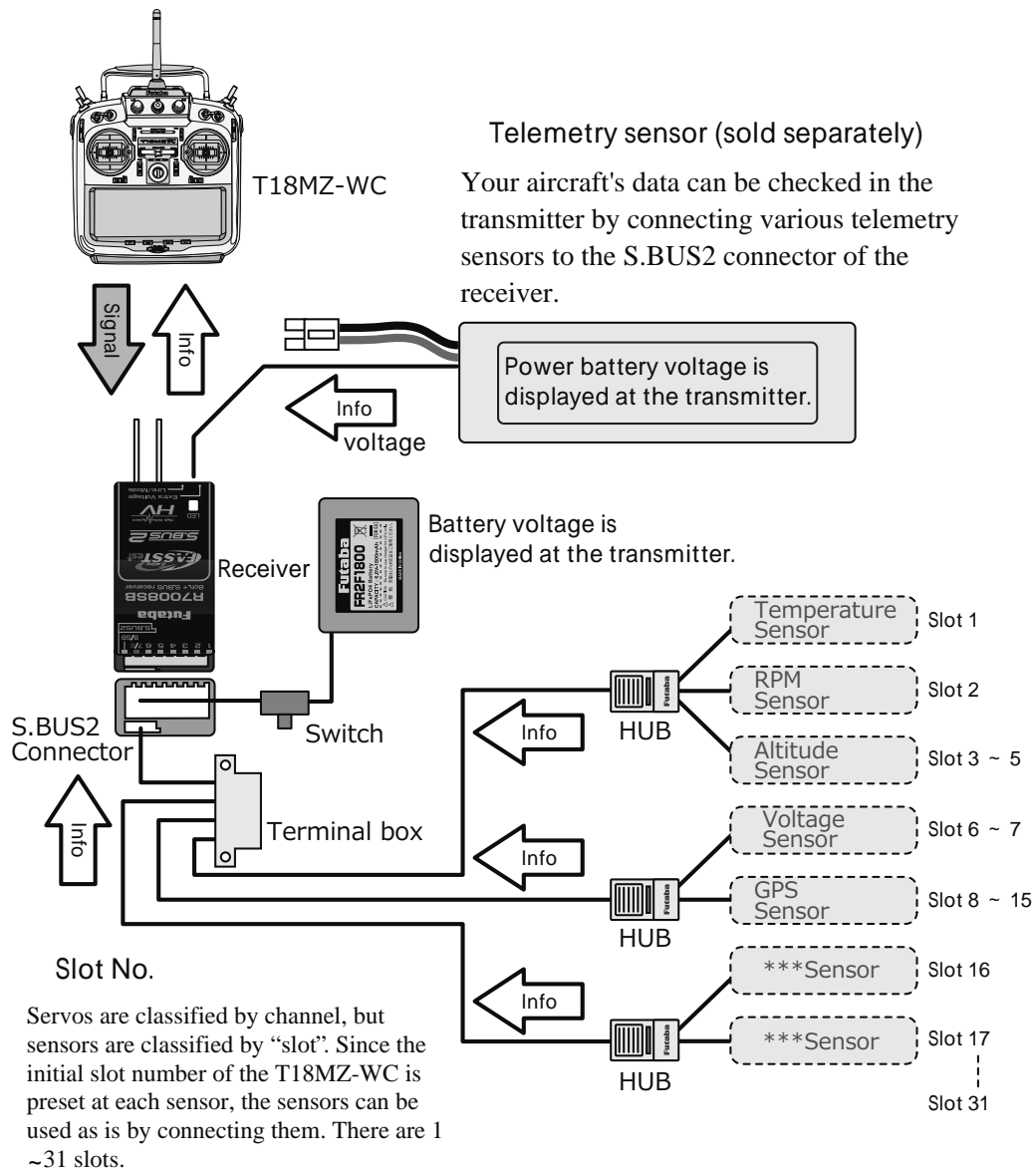

BASIC OPERATION

Battery Charging

Before charging batteries, read the "Cautions for handling battery and battery charger" in the section "For your safety".

Charging the transmitter LT2F3500XH lithium-polymer battery

⚠ DANGER

⊘ The LT2F3500XH lithium-polymer battery is for the T18MZ-WC transmitter only. Do not use it with other devices.

⚠ Always use the included AC adapter to charge the battery.

The charging circuit is built into the T18MZ-WC.

[Method of charging battery]

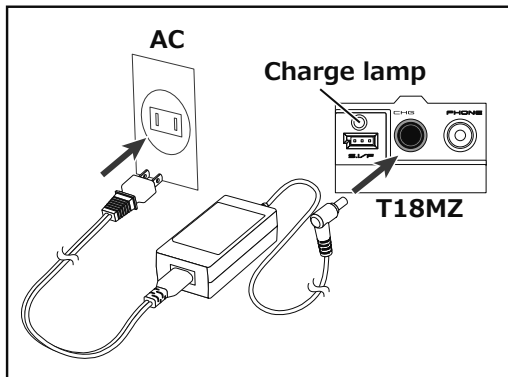

1. Turn off the transmitter power.
2. Connect the power plug of the AC adapter to an 110V outlet.
*Don't connect AC plug to the T18MZ-WC without connecting with a 110V outlet.
3. Open the back lid of the transmitter and insert the plug of the AC adapter into the CHG port.
4. The charging monitor of the transmitter lights red.
*In the case LCD screen will come on for several seconds and then go off. It may take several seconds for charging to start after the AC adapter is connected.
5. When the battery is fully charged the transmitter monitor will light green. Remove the charge plug and AC adaptor.
*After using the AC adapter always disconnect the power cord from the AC outlet.
*The time to charge a completely discharged battery pack is approximately 2 hours 30 minutes. However,

the actual charging time may vary depending on temperature and state of the battery.

*If the battery is improperly installed or is faulty, the transmitter monitor will not light and the battery will not charge.

How to charge the LiFe battery FR2F1800 (Option) for the receiver

Use the battery charger that is included in the set.

[Method of charging battery]

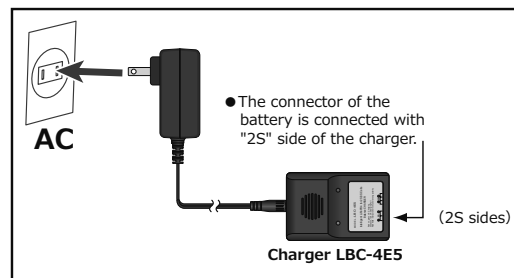

1. Connect the power cable of the charger to the wall socket (AC outlet).
2. Connect the connector to the LiFe battery.
*Confirm that the red LED charging indicator lights are on.
3. Remove the battery after the LED light turns green.
*After completing the charge remove the battery from the charger and remove the charger from the wall outlet.

⚠ WARNING

⊘ The transmitter battery cannot be charged with the receiver charger. Conversely the receiver battery cannot be charged with the transmitter charger.

How to turn ON/OFF the power of the transmitter

Windows® CE is installed as a built-in operating system in the T18MZ-WC transmitter. Compared to the conventional system, the T18MZ-WC takes extra time for internal processing when it is turned on/off.

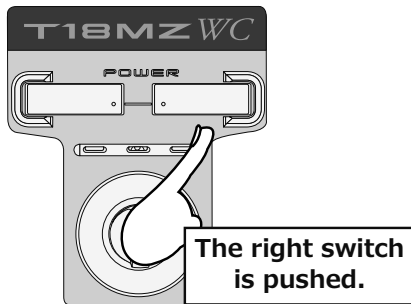

When turning on the power of the transmitter

1. Place the throttle stick below 1/3 closed.
2. Turn on the power switch.

*After initialization of the transmitter is complete, the LED monitor turns Purple.

*If your throttle stick is not at 1/3 closed or fully closed, a warning will sound. If you move the throttle to 1/3 closed or fully closed, the warning will stop and will become a "Transmit ?" screen.

*If you push the button "NO", then the transmitter will not emit radio waves.

*If you push the button "Yes", then the transmitter will emit radio waves.

*If a battery is removed and it re-connects, please switch on a power supply, after 3 seconds or more pass.

Start-up time;

The time required to initialize the internal circuit of the transmitter varies between the previous time you turned the power off and then restarted the transmitter. There are two "start up" modes for your transmitter, see below:

Cold start;

If you turn on the transmitter more than four hours after you last turned it off, the mode is "Cold start". "Cold start" is normal for the first initial power up of the day. It will take about 30 seconds to be ready for use, as it takes time to initialize the internal circuit of the transmitter.

Hot start;

If you turn on the transmitter less than four hours after you last turned it off, the mode is "Hot start". Since initialization has been partly completed, the transmitter will be ready to use in several seconds.

"Hot start" takes place usually at a second flight or later flight in the day.

⚠ WARNING

- ⊘ Once you turn on the power, never shut off the power switch until the power becomes stable (or until the first screen shows up). If you turn off the power switch while the transmitter is going through the initialization process, the data could be damaged.

Note: The start-up time may be a little bit slower when the SD card is installed compared to when the card is not.

How to stop the transmitter

Turn off the power switch of the transmitter. The internal circuit of the transmitter starts the shut down process including saving the set-up data.

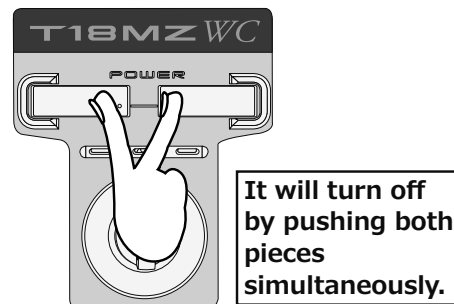

or

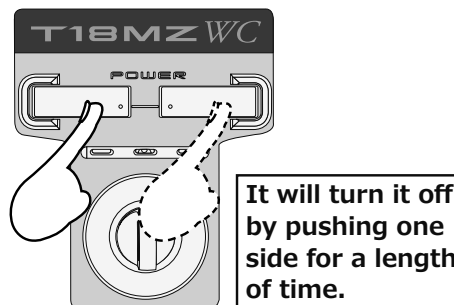

- ⊘ Once you turn off the power, never operate the power switch until the power shutdown process is fully completed. If you turn on the power switch again while the transmitter is still in the process of power shutdown, the data could be damaged.

How to reset software

If the screen freezes for some reason and you cannot edit, the transmitter power supply is not fully off even if you turn OFF the power switch. You will need to remove the battery and reinsert it again. In this case, the power restarts in "Cold mode". Even though the screen freezes, all the other functions for radio control operation remain operative.

Registration of the user's name

T18MZ-WC transmitter can register user's name.

How to register user's name

1. Turn on the power of the transmitter.
2. Push the area of the user's name shown on the home screen or the "user's name" in the system menu. Then the User's Name Set screen will pop up.



3. Push the user's name. Then the keyboard will pop up. You can use up to 32 characters as a user's name. Use the keyboard on the screen to enter user's name.



Space key

4. Push "Return" key to return to the previous screen after entering the user's name.

(If you want to protect the user's name)

If you don't want anybody else to change your user's name, set your ID in the following way.

*Please be aware that you will not be able to change user's name if you forget your password.

1. Make sure that the security mode is "User's name", and then push the User ID button.
2. Enter your password, using keyboard on the screen. You will need to enter your password for changing the user's name, the next time you turn on the power.

*Even if you enter the same character, your password will be identified differently depending on whether you are using "Transform" mode or "Direct" mode for inputting.

Home screen

This is the Home screen and descriptions of its menus. Use your finger or included stylus pen to operate the touch screen.

<p>Timer</p> <p>If one of two timer displays is pushed, you will enter the Timer screen of a Linkage menu.</p> <p>In the button mode of a timer set, it can also be made a start/stop.</p> <p>A push on reset will reset a time.</p>
<p>Menu Button</p> <ul style="list-style-type: none"> • System menu • Linkage menu
<p>System Selection</p> <ul style="list-style-type: none"> • FASSTest18CH • FASSTest12CH • FASST MULTI • FASST 7CH • S-FHSS • T-FHSS
<p>System timer/Reset</p> <ul style="list-style-type: none"> • This shows the total accumulated time used for the transmitter. This can be reset. (Hour):(Minute):(Second) <p>Push this area to reset the timer.</p>
<p>Voltage of Rx/Ext battery</p> <p>Information from the receiver is displayed when using a bidirectional system.</p> <p>FASSTest/T-FHSS Only.</p>
<p>Direct buttons</p> <p>Select and press one of the direct buttons to enter the menu.</p>
<p>Home2</p> <p>A timer and Telemetry data change to Home2 screen by which it was indicated by expansion.</p>
<p>RF Indicator</p> <p>"ON AIR" or "RF OFF"</p>
<p>Digital trim (T1 to T6, CD)</p> <p>Push this area to enter the Dial Monitor screen.</p>

<p>User's name</p> <p>Push this area to enter the User's Name Setting screen.</p>
<p>Condition</p> <p>The condition name that is currently used is displayed here.</p> <ul style="list-style-type: none"> • Push this area to enter the Condition Select screen.
<p>Battery Indicator</p> <ul style="list-style-type: none"> • When the remaining battery reaches 30%, the alarm will beep. Land your aircraft immediately.
<p>Menu Button</p> <ul style="list-style-type: none"> • Model menu
<p>Model Name</p> <p>The model name that is currently used is displayed here.</p> <ul style="list-style-type: none"> • Push this area to enter the Model Select screen.
<p>Clock</p> <p>This shows the today's date and the current time.</p> <ul style="list-style-type: none"> • Push this area for the Date & Time Setting screen.

⚠ WARNING

- ⚠ Be sure to confirm the model name before flying your aircraft.
- ⚠ Check the remaining battery as often as possible and try to charge the battery regularly. If the battery alarm sounds and its warning symbol is displayed, land your aircraft immediately.

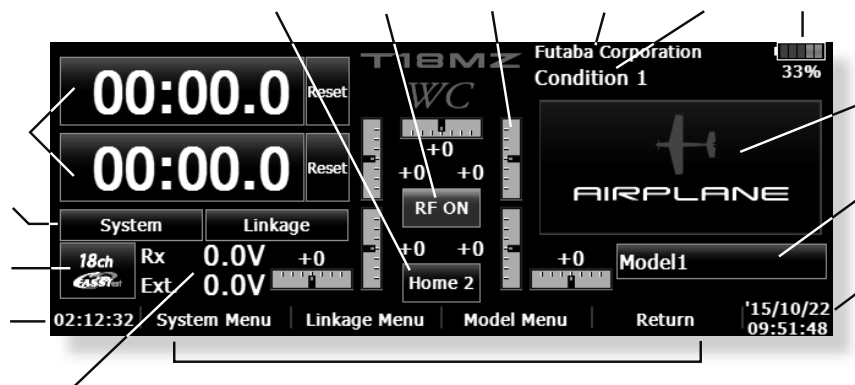

Home 2 screen

If [Home2] is pushed, it will become the display to which the timer and the Telemetry data were expanded.

• Return to home screen

Timer
If one of two timer displays is pushed, you will enter the Timer screen of a Linkage menu.

• Three telemetry data screens can be displayed.
If three either is pushed, it will move to a telemetry screen.
Three displays can be changed on a telemetry screen.

User Menu

T18MZ-WC has a menu for each of the following: System, Linkage, and Model. Also, you can create a personalized User Menu that can include all of the menus that you use most often.

The User menu can be created by pressing the Rotary Key.

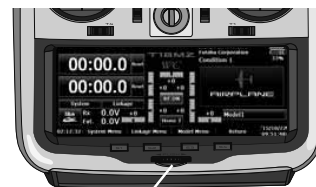

How to make a User Menu

1. From the home screen, press the Rotary key for 2 seconds.
2. Touch here to select your first choice.
3. Once pressed, 4 pages of choices will be displayed.
4. Make your selection, press your choice and the first of your "User Menu" will be entered.

• Return to home screen

User Menu	Model1	Normal	100%	1/2
-----	-----	-----	-----	-----
-----	-----	-----	-----	-----
-----	-----	-----	-----	-----
INH	Condition Hold	System Menu	Linkage Menu	Model Menu

• Return to User Menu

User Menu (Reg.)	Model1	Normal	100%	1/3
Trainer	Display	Date and Time	User Name	
Switch	H/W Setting	Sound Volume	Player	
Camera	S.BUS Servo	Information	Servo Monitor	
Model Select	Model Type	Picture	Sound	
INH	Condition Hold	System Menu	Linkage Menu	Model Menu

• Return to home screen

User Menu	Model1	Normal	100%	1/2
AFR (D/R)	Prog. Mixes	PIT Curve	THR Curve	
-----	-----	-----	-----	
-----	-----	-----	-----	
INH	Condition Hold	System Menu	Linkage Menu	Model Menu

*Any change made to data entered from the User Menu or from the normal method of use are the same. Changes made in either way are saved into the transmitter memory.

- To erase a selection from your User Menu, highlight the desired menu and press Release. This will remove it from your personal User Menu, but not from the basic menu. You can always go back at a later date and re-enter this into your User Menu.

MODEL BASIC SETTING PROCEDURE

Airplane/glider basic setting procedure

1. Model addition and call

Initial setting assigns one model to the T18MZ-WC transmitter. The Model Select function of the Linkage Menu is used to add models and to select models which have already been set.



This is convenient when calling a model after its name has been registered. (Data can also be saved to the accessory SD card and USB memory)

The currently called model name is displayed at the top of the screen. Before flying and before changing any settings, always confirm the model name.

When a new model is added, the model type select screen/system type/receiver link automatically appears. Please be aware that the transmitter will stop transmitting when you change the model.

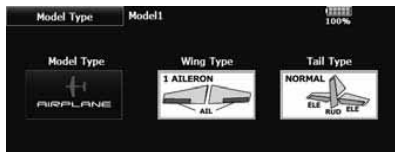

2. Model type selection

Select the model type matched to the fuselage with the Model Type select function of the Linkage Menu. For an airplane, select the model type from among the 3 types: airplane, glider, and motor glider. When the wing type select screen is displayed and the wing type is selected when selecting the model type, the tail type select screen is displayed. Select the tail type matched to the fuselage.

There are 13 wing types and 3 tail types for airplane, glider, and motor glider.

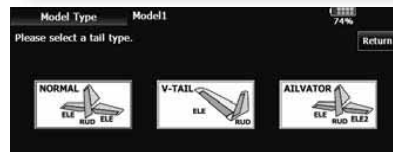
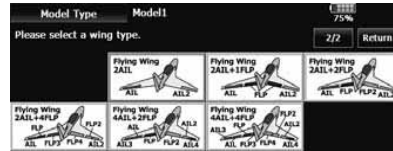
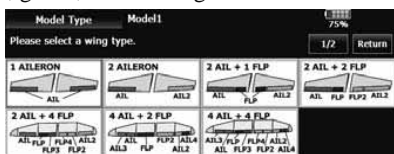

3. Fuselage linkage

Link the ailerons, elevators, throttle, rudder, etc. in accordance with the model's instruction manual. For a description of the connection method, see the receiver and servos connection.

Note: The channel assignment of the T18MZ-WC is different from that of our existing systems. Note that even for the same "airplane model", when the wing type and tail type are different, the channel assignment has been optimized and may be different. (The channel assigned to each function can be checked in the Function menu of the Linkage Menu.)

CH	Function	Control	Trim	CH	Function	Control	Trim
1	Aileron	J1	T1	7	Auxiliary1	NULL	NULL
2	Elevator	J3	T3	8	Auxiliary2	NULL	NULL
3	Throttle	J2	T2	9	Auxiliary3	NULL	NULL
4	Rudder	J4	T4	10	Auxiliary4	NULL	NULL
5	Air Brake	RST	NULL	11	Auxiliary5	NULL	NULL
6	Gear	SG	NULL	12	Auxiliary6	NULL	NULL

- When the direction of the linkage is reversed, adjust the direction with the Servo Reverse function in the Linkage Menu.

CH	Function	Setting	CH	Function	Setting	CH	Function	Setting
1	Aileron	NORM	7	Auxiliary5	NORM	13	Auxiliary1	NORM
2	Elevator	NORM	8	Auxiliary4	NORM	14	Auxiliary1	NORM
3	Throttle	NORM	9	Auxiliary3	NORM	15	Auxiliary1	NORM
4	Rudder	NORM	10	Auxiliary2	NORM	16	Auxiliary1	NORM
5	Gear	NORM	11	Auxiliary1	NORM			
6	Air Brake	NORM	12	Auxiliary1	NORM			

- Connect the throttle linkage so the carburetor is open at full trim and full open so that the throttle can be cut.
- Adjust the neutral position and rudder angle with the linkage, and fine tune them with the Sub Trim and End Point functions (rudder angle adjustment). To protect the linkage, a limit position can also be set with the End Point function. The End Point function can adjust the amount of up/down and left/right movement, limit, and servo speed of each channel.

4. Throttle cut setting (In case of engine model)

Throttle cut can be performed with one touch by a switch without changing the throttle trim position.

Set throttle cut with the Throttle Cut function of the Linkage Menu. After activating the throttle cut function and selecting the switch, adjust the throttle position so that the carburetor becomes full close. For safety, the throttle cut function operates the throttle stick in the slow position.



5. Idle down setting (In case of engine model)

The idling speed can be lowered with one touch by a switch without changing the throttle trim position. Perform this setting with the Idle Down function of the Linkage Menu. After activating the Idle Down function and selecting the switch, adjust the idle down speed. For safety, the idle down function acts only when the throttle stick is in the slow position.

*While the Throttle Cut function is in operation, the Idle Down function does not work.

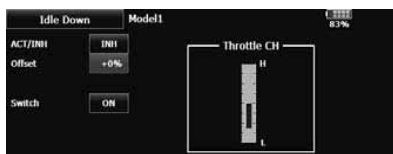

6. AFR (D/R)

AFR function is used to adjust the throw and operation curve of the stick, lever, and switch functions for each flight condition. This is normally used after End Point (ATV) has defined the maximum throw directions (End Point acts on ALL flight condition settings). When mixing is applied from one channel to another channel, both channels can be adjusted at the same time by adjusting the operation rate through the AFR function.



7. Airbrake

This function is used when an air brake is necessary when taking off or diving, etc.

The preset elevators and flaps (camber flap, brake flap) offset amount can be activated by a switch.

The offset amount of the aileron, elevator, and flap servos can be adjusted as needed. Also the speed of the aileron, elevator, and flap servos can be adjusted. (IN side/OUT side) A delay can be set for each condition, and a cut switch which will turn OFF the delay can be chosen. Trim amounts can be fine-tuned by setting a VR. You can also set the auto mode, which will link Airbrake to a stick, switch, or dial. A separate stick switch or dial can also be set as the ON/OFF switch.

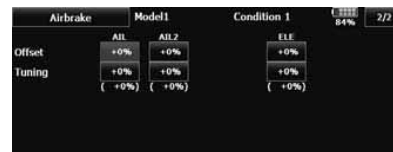

8. Addition of flight conditions

The transmitter can install up to eight flight conditions per model. You can assign all switches including sticks, switches, trim levers and trim switches as flight-condition selection switches. You can also add delayed mixing to these functions in order to avoid sudden changes. Moreover, you can set priority order for flight conditions when you set more than one condition. In addition, you can copy conditions and/or change names of conditions. This command may also be used to define what switches and/or controls are used to activate each flight condition.

The Condition Select function automatically allocates the condition 1 for each model type. Condition 1 is the default condition, also referred to as normal, and is the only one active when a new model type is defined. This condition is always ON, and remains ON until other conditions are activated by switches.

The Condition Delay can be programmed for each channel. The Condition Delay is used to change the servo throw smoothly when switching conditions.

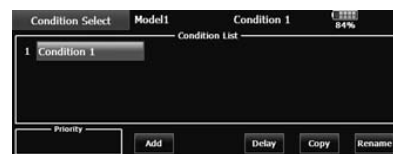

*When a new condition is added, "Condition1" data is automatically copied.

*Select the condition switch and set the new condition data with the switch in the ON position. However, if the group mode (Gr.) was selected in advance, the same data will be input to all new conditions. Select the single mode (Sngl) and adjust the condition you want to change.

Helicopter basic setting procedure

1. Model addition and call

Default settings assign one model to the T18MZ-WC transmitter. To add new models or select previously setup models, use the Model Select function in the Linkage Menu.



This is convenient when calling a model after registering the model names in advance. (Data can also be saved to the accessory SD card and USB memory)

The currently called model is displayed at the top of the screen. Before flying and before changing any settings, always confirm the model name.

Please be aware that the transmitter will stop transmitting when you change the model.

When a new model is added, the model type select screen/system mode/receiver link automatically appears. Please be aware that the transmitter will stop transmitting when you change the model.



2. Model type and swash type selection

When a separate model type is already selected, select helicopter with the Model Type function of the Linkage Menu, and then select the swash type matched to the fuselage.

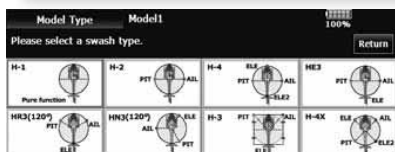
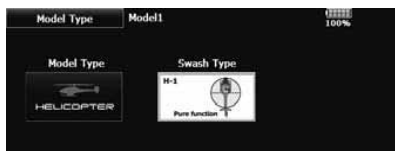

3. Flight condition addition

The transmitter can install up to eight flight conditions per model. You can assign all switches including sticks, switches, trim levers and trim switches as flight-condition selection switches. You can also add delayed mixing to these functions in order to avoid sudden changes. Moreover, you can set priority order for flight conditions when you set more than one condition. In addition, you can copy conditions and/or change names of conditions. This command may also be used to define what switches and/or controls are used to activate each flight condition.

The Condition Select function automatically allocates the default Condition 0 (Normal) for each model type. Condition 0 (Normal) is the only one active when a new model type is defined. This condition is always ON, and remains ON until other conditions are activated by switches.

The Condition Delay can be programmed for each channel. The Condition Delay is used to change the servo throw smoothly when switching conditions.



(General flight condition setting example)

- Normal: (Use initial setting conditions/operate when switch OFF)
Use from engine starting to hovering.
- Idle up 1: (Switch setting example: Operate at SW-E center)
Use in stall turn, loop, and other maneuvers.
- Idle up 2: (Switch setting example: Operate at SW-E forward side)
Use in rolls.
- Throttle hold: (Switch setting example: Operate at SW-G forward side)
Use in auto rotation.

The priority is throttle hold/idle up 2/idle up 1/normal. Throttle hold has the highest priority.

Add other conditions, as required.

4. Fuselage linkage

Connect the throttle rudder, ailerons, elevators, pitch, and other rudder linkages in accordance with the kit instruction manual. For a description of the connection method, see "Receiver and servos connection".

*The channel assignment of the T18MZ-WC is different from that of our existing systems. (The channel assigned to each function can be checked at the function menu of the Linkage Menu.)

CH	Function	Control	Trim	CH	Function	Control	Trim
1	Aileron	J1	T1	7	Governor	NULL	NULL
2	Elevator	J3	T3	8	Governor2	NULL	NULL
3	Throttle	J2	T2	9	Needle	LST	NULL
4	Rudder	J4	T4	10	Gyro2(AIL)	NULL	NULL
5	Gyro(RUD)	NULL	NULL	11	Gyro3(ELE)	NULL	NULL
6	Pitch	J2	NULL	12	Auxiliary1	NULL	NULL

- When the direction of the linkage is reversed, use the Reverse function of the Linkage Menu. Also use the swash AFR function in any swash setup other than the H-1 mode.

CH	Function	Setting	CH	Function	Setting	CH	Function	Setting
1	Aileron	NORM	7	Governor	NORM	13	Auxiliary2	NORM
2	Elevator	NORM	8	Governor2	NORM	14	Auxiliary3	NORM
3	Throttle	NORM	9	Needle	NORM	15	Auxiliary4	NORM
4	Rudder	NORM	10	Gyro2(AIL)	NORM	16	Auxiliary5	NORM
5	Gyro(RUD)	NORM	11	Gyro3(ELE)	NORM		DG1	NORM
6	Pitch	NORM	12	Auxiliary1	NORM		DG2	NORM

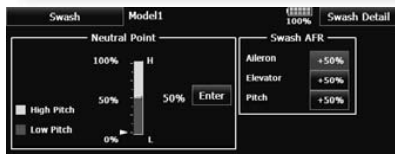

- Adjust the direction of operation of the gyro. (Gyro side function)
- Connect the throttle linkage so it is fully closed with the trim setting all the way down.
- Adjust the neutral position and rudder angle at the linkage side and fine tune with the Sub-Trim function and End Point function (rudder angle adjustment). To protect the linkage, a limit position can also be set with the End Point function.

CH1	CH2	CH3	CH4	CH5	CH6	CH7	CH8	CH9	CH10	CH11	CH12	CH13	CH14	CH15	CH16
+	+	+	+	+	+	+	+	+	+	+	+	+	+	+	+
AIL	ELE	THR	RUD	GYR	PET	GOV	GOV2	NEE	GYR2	GYR3	AUX1	AUX2	AUX3	AUX4	AUX5

CH	Function	Limit	Travel	Travel	Limit	Speed
1	Aileron	135%	100%	100%	135%	0
2	Elevator	135%	100%	100%	135%	0
3	Throttle	135%	100%	100%	135%	0
4	Rudder	135%	100%	100%	135%	0
5	Gyro(RUD)	135%	100%	100%	135%	0
6	Pitch	135%	100%	100%	135%	0

- Swash plate correction (Except H-1 mode)

Operation of the swash plate near the hovering point can be corrected by swash AFR function correction mixing. Use this when pitch, aileron, and elevator operation causes the swash plate to deviate from the normal direction.

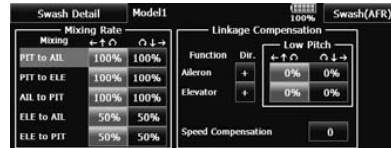

(Call the Swash setup→Swash details screen.) Pitch slow side and high side linkage correction is also possible. Adjust so that pitch operation causes the swash plate to move up and down in the horizontal state.

5. Throttle curve setting

This function adjusts the pitch operation curve in relation to the movement of the throttle stick for each condition.

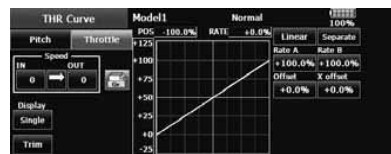

(17 points curve)

The pitch curve can be freely selected from linear operation curve to smooth curve, and adjusted to match the curve you want by means of the T18MZ-WC's powerful Curve Edit Function (6 types of curves can be selected). Up to 17 points can be set for linear or curve types. However, when using the 3 points or 5 points specified to create a curve, a simple and smooth curve can be created by selecting the curve type and reducing the number of input points to 3 or 5, and then entering the specified value at the corresponding points that you created.

<Setting example>

Call the throttle curve of each condition with the condition select switch.

- Normal curve adjustment**
Normal curve uses Normal (Linear) type and creates a basic pitch curve centered near hovering. This curve is adjusted together with the Throttle Curve (Normal) so that the engine speed is constant and up/down control is easiest.
- Idle up curve adjustment**
The high side pitch curve sets the maximum pitch regardless of the engine load. The low side pitch curve creates a curve matched for aerobatics (loop, roll, 3D, etc.).

Note: When the curve type is changed, the data is reset.

- Throttle hold curve adjustment

The throttle hold curve is used when performing auto rotation dives.

Confirm that the rate of the slowest position (0%) of the stick is 0% (initial setting).
Be sure that when set to high side 100%, the curve of any condition does not exceed 100%.

Example of pitch curve setting:

1. Call the pitch curve of each condition with the condition select switch.

*Pitch curve graph display can be switched to pitch angle direct reading display.

A. Pitch curve (Normal)

Make the pitch at hovering approximately $+5^{\circ}$ ~ 6° .
Set the pitch at hovering with the stick position at the 50% point as the standard.

*Stability at hovering may be connected to the throttle curve.
Adjustment is easy by using the hovering throttle function and hovering pitch function together.

B. Pitch curve (Idle up 1)

The idle up 1 pitch curve function creates a curve matched to airborne flight.
Set to -7° ~ $+12^{\circ}$ as standard.

C. Pitch curve (Idle up 2)

The high side pitch setting is less than idle up 1.
The standard is $+8^{\circ}$.

D. Pitch curve (Hold)

At auto rotation, use the maximum pitch at both the high and low sides.
[Pitch angle setting example]
Throttle hold: -7° ~ $+12^{\circ}$

6. Throttle hold setting

Call the Throttle Hold function from the Model Menu and switch to the throttle hold condition with the condition select switch.

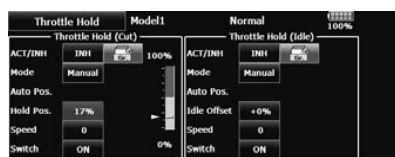

Note: At initial setting, the setting mode is the group mode. Since this function is not used at other conditions, switch to the single mode before setting.

- Setting to the state which activates the function
The throttle hold function allows setting for throttle cut and switching of the function fixed at the idle position by switch for training. Either one or both functions can be performed.
- Hold position setting
This function sets the servo operation position at throttle hold. (Throttle cut and idle positions)
- Other settings
When you want to link operation with stick manipulation, the Auto mode can be set.
When you want to adjust the servo speed, adjust [Speed].

7. Pitch to RUD mixing setting

Use this function when you want to suppress the torque generated by the changes in the pitch and speed of the main rotor during pitch operation. Adjust it so that the nose does not swing in the rudder direction. However, when using a heading hold gyro like those shown below, do not use Pitch to RUD mixing.

Note: When using a Futaba GY series gyro, or other heading hold gyro, this Pitch to RUD mixing should not be used. The reaction torque is corrected at the gyro side. When operating the gyro in the AVCS mode, the mixed signal will cause neutral deviation symptoms and the gyro will not operate normally.

Call the Pitch to RUD mixing function from the Model Menu, and set the curve for each condition. (At initial setting, this function is in the "INH" state. To use it, set it to the "ON" state.)

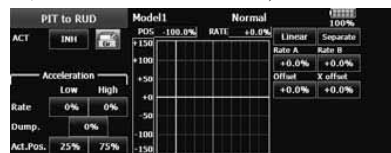

(17 points curve)

Curve setting of up to 17 points is possible. However, in the following setting example, a simple curve can be adjusted by using the [Linear] curve type.

Note: At initial setting, the setting mode is the group mode. In this mode, the same contents are set at in all conditions. When you want to set the selected condition only, switch to the single mode.

<Setting example>

Call the mixing curve of each condition with the condition select switch.

1. A curve setting example is shown below.

A. Pitch to RUD mixing curve (Normal)

Use the hovering system and set this curve to match take off and landing and vertical climb at a constant speed.

*For this curve, use the initial setting [Linear] curve type and adjust the left and right rates in the [Separate] mode.

B. Pitch to RUD mixing (Idle up 1)

Use this curve in stall turn, loop, and adjust it so the fuselage is facing straight ahead when heading into the wind.

*For this curve, [Linear] curve type can be used and the entire curve can be lowered with the [Offset] button.

C. Pitch to RUD mixing (Hold)

This function is set so that the fuselage is facing straight ahead during straight line auto rotation. The pitch of the tail rotor becomes nearly 0°.

*For this curve, [Linear] curve type can be used and the entire curve can be lowered with the [Offset] button.

•Other settings

The mixing rise characteristic of pitch operation can be adjusted. An acceleration (ACLR) function, which temporarily increases and decreases the mixing amount, can be set.

8. Swash Mix corrects aileron, elevator and pitch interaction

The swash mix function is used to correct the swash plate in the aileron (roll) direction and elevator (cyclic pitch) corresponding to each operation of each condition.



9. Throttle mixing setting

RPM loss caused by swash operation of aileron or elevator can be corrected with the Throttle Mix function in the Model Menu. The effects of clockwise and counterclockwise torque applied when pirouetting can also be corrected.



10. Gyro sensitivity and mode switching

The gyro sensitivity and mode switching function is dedicated to gyro mixing for each model used, and can be set for each condition.



- Normal condition (hovering): Gyro sensitivity maximum
- Idle up 1/Idle up 2/Throttle hold: Gyro sensitivity minimum
- However, at auto rotation of a tail-driven helicopter, this function may not have any affect at high gyro sensitivity.

11. Throttle cut setting

Throttle cut provides an easy way to stop the engine, by flipping a switch with the throttle stick at idle. The action is not functional at high throttle to avoid accidental dead sticks. The switch's location and direction must be chosen, as it defaults to NULL.

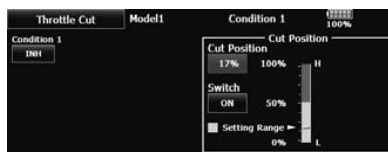

*With throttle stick at idle, adjust the cut position until the engine consistently shuts off, but throttle linkage is not binding. When finished, touch the "Throttle Cut" button to exit.

12. Other special mixings

- Pitch to Needle mixing
This mixing is used with engines with a construction which allows needle control during flight (fuel-air mixture adjustment). A needle curve can be set. The needle servo rise characteristics at throttle stick acceleration/deceleration operation can be adjusted. (Acceleration function)
- Fuel mixture function
This mixing is used in needle adjustment of engines which use a fuel mixture control carburetor.
- Governor mixing
This mixing is dedicated governor mixing when a governor is used. Up to 3 rates (speeds) can be switched for each condition.

Servos connection by model type

The T18MZ-WC transmitter channels are automatically assigned for optimal combination according to the type selected with the Model Type function of the Linkage Menu. The channel assignment (initial setting) for each model type is shown below. Connect the receiver and servos to match the type used.

*The set channels can be checked at the Function screen of the Linkage Menu. The channel assignments can also be changed. For more information, read the description of the Function menu.

Airplane/glider/motor glider

•Airplane and V tail

RX CH	1AIL			2AIL			2AIL+1FLAP			2AIL+2FLAP			The output Ch of each system ↓ FASSTest 18CH FASSTest 12CH S-FHSS FASSTest 12CH FASSTest 18CH FASST MULT T-FHSS
	Airplane	Glider		Airplane	Glider		Airplane	Glider		Airplane	Glider		
		EP			EP			EP			EP		
1	Aileron	Aileron	Aileron	Aileron	Aileron	Aileron	Aileron	Aileron	Aileron	Aileron	Aileron	Aileron	
2	Elevator	Elevator	Elevator	Elevator	Elevator	Elevator	Elevator	Elevator	Elevator	Elevator	Elevator	Elevator	
3	Throttle	Motor	AUX7	Throttle	Motor	AUX7	Throttle	Motor	AUX7	Throttle	Motor	AUX7	
4	Rudder	Rudder	Rudder	Rudder	Rudder	Rudder	Rudder	Rudder	Rudder	Rudder	Rudder	Rudder	
5	Gear	AUX6	AUX6	Gear	AUX6	AUX6	Gear	AUX6	AUX6	Aileron2	Aileron2	Aileron2	
6	Airbrake	Airbrake	Airbrake	Aileron2	Aileron2	Aileron2	Aileron2	Aileron2	Aileron2	Flap	Flap	Flap	
7	AUX5	AUX5	AUX5	AUX5	AUX5	AUX5	Flap	Flap	Flap	Flap2	Flap2	Flap2	
8	AUX4	AUX4	AUX4	AUX4	AUX4	AUX4	AUX5	AUX5	AUX5	Gear	AUX6	AUX6	
9	AUX3	AUX3	AUX3	AUX3	AUX3	AUX3	AUX4	AUX4	AUX4	AUX5	AUX5	AUX5	
10	AUX2	AUX2	AUX2	AUX2	AUX2	AUX2	AUX3	AUX3	AUX3	AUX4	AUX4	AUX4	
11	AUX1	AUX1	AUX1	AUX1	AUX1	AUX1	AUX2	AUX2	AUX2	AUX3	AUX3	AUX3	
12	AUX1	AUX1	AUX1	AUX1	AUX1	AUX1	AUX1	AUX1	AUX1	AUX2	AUX2	AUX2	
13	AUX1	AUX1	AUX1	AUX1	AUX1	AUX1	AUX1	AUX1	AUX1	AUX1	AUX1	AUX1	
14	AUX1	AUX1	AUX1	AUX1	AUX1	AUX1	AUX1	AUX1	AUX1	AUX1	AUX1	AUX1	
15	AUX1	AUX1	AUX1	AUX1	Butterfly	Butterfly	AUX1	Butterfly	Butterfly	AUX1	Butterfly	Butterfly	
16	AUX1	AUX1	AUX1	Camber	Camber	Camber	Camber	Camber	Camber	Camber	Camber	Camber	
DG1	SW	SW	SW	SW	SW	SW	SW	SW	SW	SW	SW	SW	
DG2	SW	SW	SW	SW	SW	SW	SW	SW	SW	SW	SW	SW	

RX CH	2AIL+4FLAP			4AIL+2FLAP			4AIL+4FLAP			The output Ch of each system ↓ FASSTest 18CH FASSTest 12CH S-FHSS FASSTest 12CH FASSTest 18CH FASST MULT T-FHSS
	Airplane	Glider		Airplane	Glider		Airplane	Glider		
		EP			EP			EP		
1	Aileron	Aileron	Aileron	Aileron	Aileron	Aileron	Aileron	Aileron	Aileron	
2	Elevator	Elevator	Elevator	Elevator	Elevator	Elevator	Elevator	Elevator	Elevator	
3	Throttle	Rudder	Rudder	Throttle	Rudder	Rudder	Throttle	Rudder	Rudder	
4	Rudder	Aileron2	Aileron2	Rudder	Aileron2	Aileron2	Rudder	Aileron2	Aileron2	
5	Gear	Flap	Flap	Gear	Aileron3	Aileron3	Gear	Aileron3	Aileron3	
6	Aileron2	Flap2	Flap2	Aileron2	Aileron4	Aileron4	Aileron2	Aileron4	Aileron4	
7	Flap	Flap3	Flap3	Aileron3	Flap	Flap	Aileron3	Flap	Flap	
8	Flap2	Flap4	Flap4	Aileron4	Flap2	Flap2	Aileron4	Flap2	Flap2	
9	Flap3	Motor	AUX7	Flap	Motor	AUX7	Flap	Flap3	Flap3	
10	Flap4	AUX6	AUX6	Flap2	AUX6	AUX6	Flap2	Flap4	Flap4	
11	AUX5	AUX5	AUX5	AUX5	AUX5	AUX5	Flap3	Motor	AUX7	
12	AUX4	AUX4	AUX4	AUX4	AUX4	AUX4	Flap4	AUX6	AUX6	
13	AUX3	AUX3	AUX3	AUX3	AUX3	AUX3	AUX5	AUX5	AUX5	
14	AUX2	AUX2	AUX2	AUX2	AUX2	AUX2	AUX4	AUX4	AUX4	
15	AUX1	Butterfly	Butterfly	AUX1	Butterfly	Butterfly	AUX3	Butterfly	Butterfly	
16	Camber	Camber	Camber	Camber	Camber	Camber	Camber	Camber	Camber	
DG1	SW	SW	SW	SW	SW	SW	SW	SW	SW	
DG2	SW	SW	SW	SW	SW	SW	SW	SW	SW	

●Ailevator

RX CH	1AIL			2AIL			2AIL+1FLAP			2AIL+2FLAP		
	Airplane	Glider		Airplane	Glider		Airplane	Glider		Airplane	Glider	
		EP			EP			EP			EP	
1	Aileron	Aileron	Aileron	Aileron	Aileron	Aileron	Aileron	Aileron	Aileron	Aileron	Aileron	Aileron
2	Elevator	Elevator	Elevator	Elevator	Elevator	Elevator	Elevator	Elevator	Elevator	Elevator	Elevator	Elevator
3	Throttle	Motor	AUX7	Throttle	Motor	AUX7	Throttle	Motor	AUX7	Throttle	Motor	AUX7
4	Rudder	Rudder	Rudder	Rudder	Rudder	Rudder	Rudder	Rudder	Rudder	Rudder	Rudder	Rudder
5	Gear	AUX6	AUX6	Gear	AUX6	AUX6	Elevator2	Elevator2	Elevator2	Elevator2	Elevator2	Elevator2
6	Airbrake	Airbrake	Airbrake	Aileron2	Aileron2	Aileron2	Aileron2	Aileron2	Aileron2	Aileron2	Aileron2	Aileron2
7	Elevator2	Elevator2	Elevator2	Elevator2	Elevator2	Elevator2	Flap	Flap	Flap	Flap	Flap	Flap
8	AUX5	AUX5	AUX5	AUX5	AUX5	AUX5	Gear	AUX6	AUX6	Flap2	Flap2	Flap2
9	AUX4	AUX4	AUX4	AUX4	AUX4	AUX4	AUX5	AUX5	AUX5	Gear	AUX6	AUX6
10	AUX3	AUX3	AUX3	AUX3	AUX3	AUX3	AUX4	AUX4	AUX4	AUX5	AUX5	AUX5
11	AUX2	AUX2	AUX2	AUX2	AUX2	AUX2	AUX3	AUX3	AUX3	AUX4	AUX4	AUX4
12	AUX1	AUX1	AUX1	AUX1	AUX1	AUX1	AUX2	AUX2	AUX2	AUX3	AUX3	AUX3
13	AUX1	AUX1	AUX1	AUX1	AUX1	AUX1	AUX1	AUX1	AUX1	AUX2	AUX2	AUX2
14	AUX1	AUX1	AUX1	AUX1	AUX1	AUX1	AUX1	AUX1	AUX1	AUX1	AUX1	AUX1
15	AUX1	AUX1	AUX1	AUX1	Butterfly	Butterfly	AUX1	Butterfly	Butterfly	AUX1	Butterfly	Butterfly
16	AUX1	AUX1	AUX1	Camber	Camber	Camber	Camber	Camber	Camber	Camber	Camber	Camber
DG1	SW	SW	SW	SW	SW	SW	SW	SW	SW	SW	SW	SW
DG2	SW	SW	SW	SW	SW	SW	SW	SW	SW	SW	SW	SW

The output
Ch of each
system

FASTest 18CH
FASTest 12CH
S-FHSS
FASTest 7CH

FASTest 18CH
FASTest 12CH
T-FHSS

RX CH	2AIL+4FLAP			4AIL+2FLAP			4AIL+4FLAP		
	Airplane	Glider		Airplane	Glider		Airplane	Glider	
		EP			EP			EP	
1	Aileron	Aileron	Aileron	Aileron	Aileron	Aileron	Aileron	Aileron	Aileron
2	Elevator	Elevator	Elevator	Elevator	Elevator	Elevator	Elevator	Elevator	Elevator
3	Throttle	Motor	AUX7	Throttle	Motor	AUX7	Throttle	Motor	AUX7
4	Rudder	Rudder	Rudder	Rudder	Rudder	Rudder	Rudder	Rudder	Rudder
5	Elevator2	Elevator2	Elevator2	Elevator2	Elevator2	Elevator2	Elevator2	Elevator2	Elevator2
6	Aileron2	Aileron2	Aileron2	Aileron2	Aileron2	Aileron2	Aileron2	Aileron2	Aileron2
7	Flap	Flap	Flap	Aileron3	Aileron3	Aileron3	Aileron3	Aileron3	Aileron3
8	Flap2	Flap2	Flap2	Aileron4	Aileron4	Aileron4	Aileron4	Aileron4	Aileron4
9	Flap3	Flap3	Flap3	Flap	Flap	Flap	Flap	Flap	Flap
10	Flap4	Flap4	Flap4	Flap2	Flap2	Flap2	Flap2	Flap2	Flap2
11	Gear	AUX6	AUX6	Gear	AUX6	AUX6	Flap3	Flap3	Flap3
12	AUX5	AUX5	AUX5	AUX5	AUX5	AUX5	Flap4	Flap4	Flap4
13	AUX4	AUX4	AUX4	AUX4	AUX4	AUX4	Gear	AUX6	AUX6
14	AUX3	AUX3	AUX3	AUX3	AUX3	AUX3	AUX5	AUX5	AUX5
15	AUX2	Butterfly	Butterfly	AUX2	Butterfly	Butterfly	AUX4	Butterfly	Butterfly
16	Camber	Camber	Camber	Camber	Camber	Camber	Camber	Camber	Camber
DG1	SW	SW	SW	SW	SW	SW	SW	SW	SW
DG2	SW	SW	SW	SW	SW	SW	SW	SW	SW

The output
Ch of each
system

FASTest 18CH
FASTest 12CH
S-FHSS
FASTest 7CH

FASTest 18CH
FASTest 12CH
T-FHSS

●Tail-less wing

RX CH	2AIL			2AIL+1FLAP			2AIL+2FLAP		
	Airplane	Glider		Airplane	Glider		Airplane	Glider	
		EP			EP			EP	
1	Aileron	Aileron	Aileron	Aileron	Aileron	Aileron	Aileron	Aileron	Aileron
2	AUX4	AUX4	AUX4	AUX4	AUX4	AUX4	AUX4	AUX4	AUX4
3	Throttle	Motor	AUX7	Throttle	Motor	AUX7	Throttle	Motor	AUX7
4	Rudder	Rudder	Rudder	Rudder	Rudder	Rudder	Rudder	Rudder	Rudder
5	Gear	AUX6	AUX6	Gear	AUX6	AUX6	Aileron2	Aileron2	Aileron2
6	Aileron2	Aileron2	Aileron2	Aileron2	Aileron2	Aileron2	Flap	Flap	Flap
7	AUX5	AUX5	AUX5	Flap	Flap	Flap	Flap2	Flap2	Flap2
8	AUX3	AUX3	AUX3	AUX5	AUX5	AUX5	Gear	AUX6	AUX6
9	AUX2	AUX2	AUX2	AUX3	AUX3	AUX3	AUX5	AUX5	AUX5
10	AUX1	AUX1	AUX1	AUX2	AUX2	AUX2	AUX3	AUX3	AUX3
11	AUX1	AUX1	AUX1	AUX1	AUX1	AUX1	AUX2	AUX2	AUX2
12	AUX1	AUX1	AUX1	AUX1	AUX1	AUX1	AUX1	AUX1	AUX1
13	AUX1	AUX1	AUX1	AUX1	AUX1	AUX1	AUX1	AUX1	AUX1
14	AUX1	AUX1	AUX1	AUX1	Butterfly	Butterfly	AUX1	Butterfly	Butterfly
15	Camber	Camber	Camber	Camber	Camber	Camber	Camber	Camber	Camber
16	Elevator	Elevator	Elevator	Elevator	Elevator	Elevator	Elevator	Elevator	Elevator
DG1	SW	SW	SW	SW	SW	SW	SW	SW	SW
DG2	SW	SW	SW	SW	SW	SW	SW	SW	SW

The output
CH of each
system

FASTest 180CH FASSTMULT T-FHSS
FASTest 120CH
S-FHSS
FAST 70CH

RX CH	2AIL+4FLAP			4AIL+2FLAP			4AIL+4FLAP		
	Airplane	Glider		Airplane	Glider		Airplane	Glider	
		EP			EP			EP	
1	Aileron	Aileron	Aileron	Aileron	Aileron	Aileron	Aileron	Aileron	Aileron
2	Aileron2	Aileron2	Aileron2	Aileron2	Aileron2	Aileron2	Aileron2	Aileron2	Aileron2
3	Throttle	Motor	AUX7	Throttle	Motor	AUX7	Throttle	Motor	AUX7
4	Rudder	Rudder	Rudder	Rudder	Rudder	Rudder	Rudder	Rudder	Rudder
5	Flap	Flap	Flap	Aileron3	Aileron3	Aileron3	Aileron3	Aileron3	Aileron3
6	Flap2	Flap2	Flap2	Aileron4	Aileron4	Aileron4	Aileron4	Aileron4	Aileron4
7	Flap3	Flap3	Flap3	Flap	Flap	Flap	Flap	Flap	Flap
8	Flap4	Flap4	Flap4	Flap2	Flap2	Flap2	Flap2	Flap2	Flap2
9	AUX4	AUX4	AUX4	AUX4	AUX4	AUX4	Flap3	Flap3	Flap3
10	Gear	AUX6	AUX6	Gear	AUX6	AUX6	Flap4	Flap4	Flap4
11	AUX5	AUX5	AUX5	AUX5	AUX5	AUX5	AUX4	AUX4	AUX4
12	AUX3	AUX3	AUX3	AUX3	AUX3	AUX3	Gear	AUX6	AUX6
13	AUX2	AUX2	AUX2	AUX2	AUX2	AUX2	AUX5	AUX5	AUX5
14	AUX1	Butterfly	Butterfly	AUX1	Butterfly	Butterfly	AUX3	Butterfly	Butterfly
15	Camber	Camber	Camber	Camber	Camber	Camber	Camber	Camber	Camber
16	Elevator	Elevator	Elevator	Elevator	Elevator	Elevator	Elevator	Elevator	Elevator
DG1	SW	SW	SW	SW	SW	SW	SW	SW	SW
DG2	SW	SW	SW	SW	SW	SW	SW	SW	SW

The output
CH of each
system

FASTest 180CH FASSTMULT T-FHSS
FASTest 120CH
S-FHSS
FAST 70CH

●Tail-less wing Winglet 2Rudder

RX CH	2AIL			2AIL+1FLAP			2AIL+2FLAP		
	Airplane	Glider		Airplane	Glider		Airplane	Glider	
		EP			EP			EP	
1	Aileron	Aileron	Aileron	Aileron	Aileron	Aileron	Aileron	Aileron	Aileron
2	RUD2	RUD2	RUD2	RUD2	RUD2	RUD2	RUD2	RUD2	RUD2
3	Throttle	Motor	AUX7	Throttle	Motor	AUX7	Throttle	Motor	AUX7
4	Rudder	Rudder	Rudder	Rudder	Rudder	Rudder	Rudder	Rudder	Rudder
5	Gear	AUX6	AUX6	Gear	AUX6	AUX6	Aileron2	Aileron2	Aileron2
6	Aileron2	Aileron2	Aileron2	Aileron2	Aileron2	Aileron2	Flap	Flap	Flap
7	AUX5	AUX5	AUX5	Flap	Flap	Flap	Flap2	Flap2	Flap2
8	AUX3	AUX3	AUX3	AUX5	AUX5	AUX5	Gear	AUX6	AUX6
9	AUX2	AUX2	AUX2	AUX3	AUX3	AUX3	AUX5	AUX5	AUX5
10	AUX1	AUX1	AUX1	AUX2	AUX2	AUX2	AUX3	AUX3	AUX3
11	AUX1	AUX1	AUX1	AUX1	AUX1	AUX1	AUX2	AUX2	AUX2
12	AUX1	AUX1	AUX1	AUX1	AUX1	AUX1	AUX1	AUX1	AUX1
13	AUX1	AUX1	AUX1	AUX1	AUX1	AUX1	AUX1	AUX1	AUX1
14	AUX1	AUX1	AUX1	AUX1	Butterfly	Butterfly	AUX1	Butterfly	Butterfly
15	Camber	Camber	Camber	Camber	Camber	Camber	Camber	Camber	Camber
16	Elevator	Elevator	Elevator	Elevator	Elevator	Elevator	Elevator	Elevator	Elevator
DG1	SW	SW	SW	SW	SW	SW	SW	SW	SW
DG2	SW	SW	SW	SW	SW	SW	SW	SW	SW



RX CH	2AIL+4FLAP			4AIL+2FLAP			4AIL+4FLAP		
	Airplane	Glider		Airplane	Glider		Airplane	Glider	
		EP			EP			EP	
1	Aileron	Aileron	Aileron	Aileron	Aileron	Aileron	Aileron	Aileron	Aileron
2	Aileron2	Aileron2	Aileron2	Aileron2	Aileron2	Aileron2	Aileron2	Aileron2	Aileron2
3	Throttle	Motor	AUX7	Throttle	Motor	AUX7	Throttle	Motor	AUX7
4	Rudder	Rudder	Rudder	Rudder	Rudder	Rudder	Rudder	Rudder	Rudder
5	Flap	Flap	Flap	Aileron3	Aileron3	Aileron3	Aileron3	Aileron3	Aileron3
6	Flap2	Flap2	Flap2	Aileron4	Aileron4	Aileron4	Aileron4	Aileron4	Aileron4
7	Flap3	Flap3	Flap3	Flap	Flap	Flap	Flap	Flap	Flap
8	Flap4	Flap4	Flap4	Flap2	Flap2	Flap2	Flap2	Flap2	Flap2
9	RUD2	RUD2	RUD2	RUD2	RUD2	RUD2	Flap3	Flap3	Flap3
10	Gear	AUX6	AUX6	Gear	AUX6	AUX6	Flap4	Flap4	Flap4
11	AUX5	AUX5	AUX5	AUX5	AUX5	AUX5	RUD2	RUD2	RUD2
12	AUX3	AUX3	AUX3	AUX3	AUX3	AUX3	Gear	AUX6	AUX6
13	AUX2	AUX2	AUX2	AUX2	AUX2	AUX2	AUX5	AUX5	AUX5
14	AUX1	Butterfly	Butterfly	AUX1	Butterfly	Butterfly	AUX3	Butterfly	Butterfly
15	Camber	Camber	Camber	Camber	Camber	Camber	Camber	Camber	Camber
16	Elevator	Elevator	Elevator	Elevator	Elevator	Elevator	Elevator	Elevator	Elevator
DG1	SW	SW	SW	SW	SW	SW	SW	SW	SW
DG2	SW	SW	SW	SW	SW	SW	SW	SW	SW



* Output channels differ by each system of a table. When using a system with few channels, there is a wing type which cannot be used. It cannot be used when there is a function required out of the range of the arrow of a figure.

Helicopter

●FASSTest 18CH / FASST MULTI / FASST 7CH / S-FHSS / T-FHSS

CH	H-4/H-4X Swash	All Other
1	Aileron	Aileron
2	Elevator	Elevator
3	Throttle	Throttle
4	Rudder	Rudder
5	Gyro	Gyro
6	Pitch	Pitch
7	Governor	Governor
8	Elevator2	Governor2
9	GYRO2	GYRO2
10	GYRO3	GYRO3
11	Governor2	Needle
12	Needle	AUX5
13	AUX4	
14	AUX3	
15	AUX2	
16	AUX1	
DG1	SW	
DG2		

The output CH of each system
 FASSTest 18CH S-FHSS FASST 7CH FASST MULTI T-FHSS

●FASSTest 12CH

CH	H-4/H-4X Swash	All Other
1	Aileron	Aileron
2	Elevator	Elevator
3	Throttle	Throttle
4	Elevator2	Rudder
5	Pitch	Pitch
6	Gyro	Gyro
7	Governor	Governor
8	Rudder	Governor2
9	GYRO2	GYRO2
10	GYRO3	GYRO3
DG1	SW	
DG2		

The output CH of each system
 FASSTest 12CH

SYSTEM MENU

The System Menu sets up functions of the transmitter, this does not set up any model data.

- When the System Menu button is touched, the menu shown below is called up. Touch the function button that you want to enter.



System Menu functions table

- **Trainer** : Starts and sets the trainer system.
- **Display** : Display adjustment and auto power off setting.
- **Date & Time** : Sets the date and time (system clock setting) and resets the timer.
- **User Name** : User name registration and ID Pin number.
- **Switch** : Toggle switch type setting (Set when the switch is replaced.)
- **H/W Setting** : Hardware reverse / Stick setting / Calibration.
- **Sund Volume** : Adjust the volume of: Key Operation / Error Warning / Trim & Center Click / Timer Event
- **Player** : Reproduction of music file.
- **Camera** : Built in 0.3 megapixel camera.
- **S.BUS Servo** : S.BUS servo setting.
- **Information** : Displays the program version, SD card information, and product ID.
- **Unit System** : The unit of a display is changed. (Metric↔Yard-Pound)
- **Range Check** : The output of the transmitter is lowered, for Range checking.

Trainer

Trainer system set up and use.

T18MZ-WC trainer system makes it possible for the instructor to chose which channels and operation modes that can be used in the student's transmitter. The function and rate of each channel can be set, the training method can also be matched to the student's skill level. Two transmitters must be connected by an optional Trainer Cord, and the Instructors' transmitter should be programmed for trainer operation, as described below.

When the Instructor activates the trainer switch, the student has control of the aircraft (if MIX/ FUNC/ NORM mode is turned on, the Instructor can make corrections while the student has control). When the switch is released the Instructor regains control. This is very useful if the student gets the aircraft into an undesirable situation.

- Setting data are stored to model data.
- Student rate can be adjusted at MIX/FUNC/ NORM mode.
- Activated student channels can be selected by switches.

Notes: This trainer system can be used in the following manner;

1. In the T18MZ(WC) (including FX-40, T12Z and T12FG) transmitter and a conventional transmitter, if the channel order is different. It is necessary to match the channel order in the Linkage Menu when connecting it with other than a T18MZ(WC). Or use "Trainer student channel setting function"
2. Be sure that all channels work correctly in **both transmitters before flying.**

Corresponding types of transmitters and trainer mode settings:

Types of transmitters		Instructor's transmitter settings		Student's transmitter settings			Trainer Cords
Instructor	Student	Freq. setting Mod. mode	Trainer setting CH mode	Freq. setting Mod. mode	Trainer setting CH mode	Mod. mode	
T18MZ(WC), T18SZ, T14SG, FX-22	T18MZ(WC), T18SZ, T14SG, FX-22	Arbitrary	16CH	Arbitrary	16CH	-	12FG/9C Trainer Cords
T18MZ(WC)	T14MZ, FX-40, T12Z, T12FG, FX-30	Arbitrary	12CH	PCM-G3 2.4G	12CH	PPM	
T18MZ(WC)	T8FG, FX-20	Arbitrary	12CH 8CH	FASST-MLT2 FASST-MULT	-	-	12FG Trainer Cords
T18MZ(WC)	T10C, T9C, T7C, T6EX, T4EX	Arbitrary	8CH	PPM	-	-	
T18MZ(WC)	T10CG, T7CG	Arbitrary	8CH	Arbitrary	-	-	12FG Trainer Cords
T18MZ(WC)	T10J, T8J, T6J, T6K	Arbitrary	8CH	Arbitrary	-	-	12FG/9C Trainer Cords
T14MZ, FX-40, T12Z, T12FG, FX-30	T18MZ(WC)	Arbitrary	12CH	Arbitrary	12CH	-	
T8FG, FX-20	T18MZ(WC)	Arbitrary	12CH	Arbitrary	12CH	-	
T10C, T10CG, T10J, T9C, T7C, T7CG, T8J, T6K	T18MZ(WC)	Arbitrary	-	Arbitrary	8CH	-	

- Touch the [Trainer] button in the System Menu to call the setup screen. The setup screen for the Teacher/Student mode is shown below.

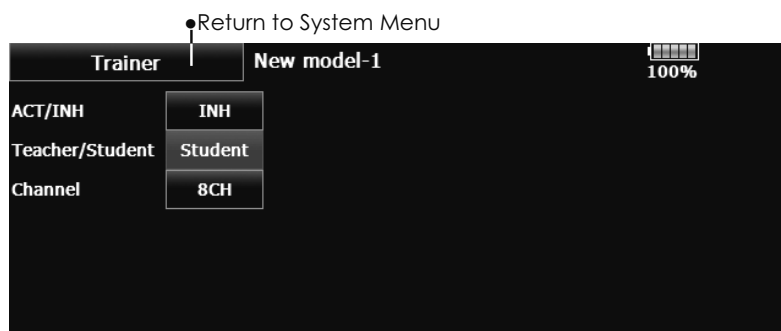

Student mode

1. Set "Teacher/ Student" button to "Student".
2. Change "ACT/INH" button from "INH" to "OFF" or "ON".
3. Set the CH mode to "16CH/12CH" or "8CH", see the above chart for the trainer mode settings.

52 < System Menu >

Note: In "student mode", only the teacher side can turn on and off the power of the student's transmitter. Keep the power switch always at off position.

AIRPLANE

GLIDER

HELICOPTER

- The setup screen for the instructor mode is shown below.

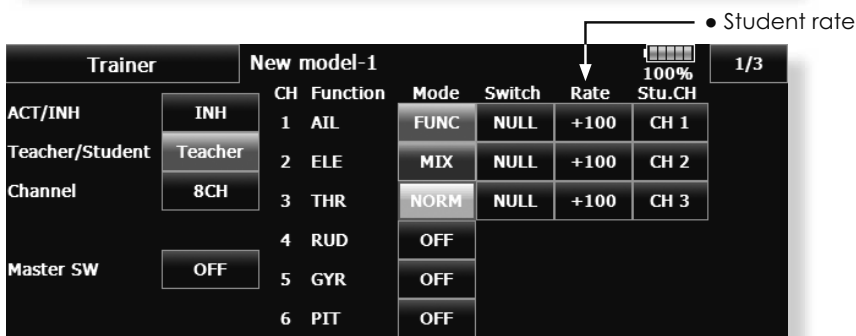
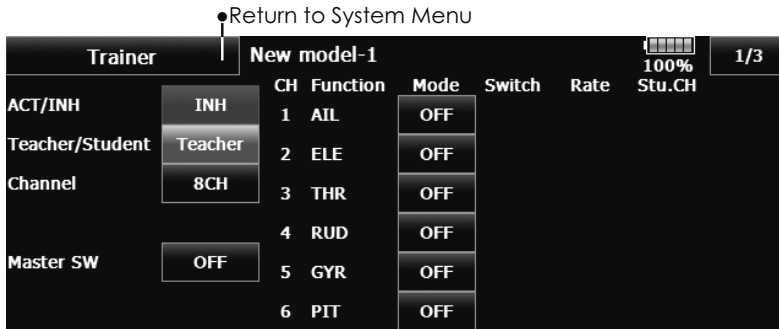

Teacher mode

1. Set "Teacher/Student" button to "Teacher".
2. Change "ACT/INH" button from "INH" to "OFF" or "ON".
3. Set the CH mode to "16CH/12CH" or "8CH", see the above-mentioned chart for the trainer mode settings.
4. Call up the Switch Setting screen by touching "Switch". Then set the desired switch and on/off direction.
5. Select the switch mode. If you select "NORM", the trainer function will be turned on or off by a switch position. If you select "ALT", ON and OFF of the trainer function switches alternatively every time the switch is turned on. This means the student side can be operated without holding the switch lever.
6. The Instructor side selects the channel for control. Three operating modes are available.
 - "NORM" mode (Normal mode);
The student will have none of the settings from the Teachers radio.
 - "MIX" mode;
Student has full advantage of all mixes and settings in Teachers radio. Plus the Teacher has the ability to override the student while the switch is activated.

"FUNC" mode (Function mode);

Student has control of all mixes and rate settings of Teachers radio.

7. Set the switches and rates of each channel.

Switch to the details setup screen by touching the page switching button [1/2] at the top right-hand corner of the screen. Student operation for each channel can be set here.

[Switch]: The switches that can be operated by the student can be set. SW-A~SWH, SS1, and SS3 can be selected.

[Rate]: Servo travel versus student operation can be set. (This can only be used in the FUNC/MIX/NORM modes.)

Note: In "teacher mode", the trainer function won't show that it is activated unless the Instructor's transmitter receives signals from the student's transmitter via the trainer cord. Be sure to confirm this after connecting your trainer cable.

AIRPLANE

GLIDER

HELICOPTER

Trainer student channel setting function

The channel function can be selected and re-arranged for the student transmitter (when using either "FUNC" "MIX" "NORM") in the Trainer function of the transmitter. This makes trainer connection easy even when the instructor and student channel assignment are different.

<Example of student CH setting>

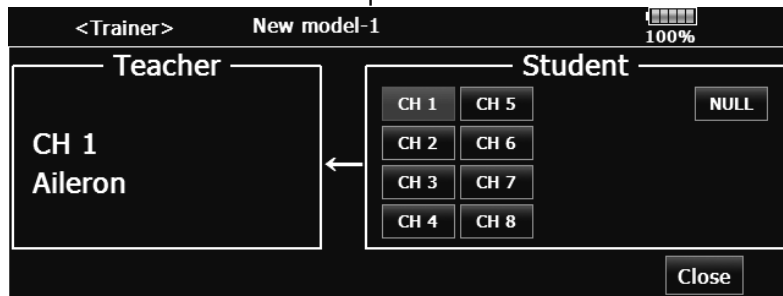
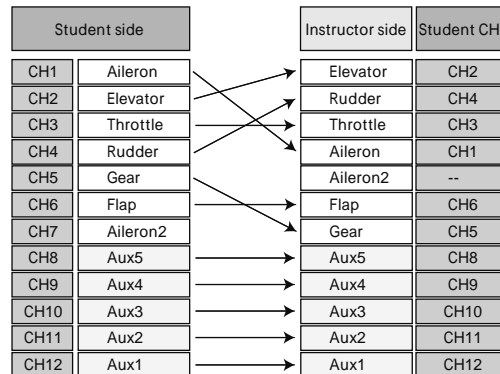

Student channel setting

1. Open the System Menu trainer screen.
2. Select [Teacher].
3. When [FUNC][MIX][NORM] is selected as the mode of the channel to be set, the [Student CH] setting button is displayed. (When [OFF],[Student CH] setting is not performed.)
4. When the [Student CH] button is pressed, the Channel Select screen is displayed. Select the channel.
 (16CH mode---1-16CH)
 (12CH mode---1-12CH)
 (8CH mode---1- 8CH)

Display

LCD screen adjustment and auto power off setting

The following LCD screen adjustments and auto power off setting are possible:

- Auto power off time setting
 - Backlighting brightness adjustment
 - Background color change
 - Touch panel screen calibration and touch-panel lock correction
- Touch the [Display] button in the System Menu to call the setup screen shown below.

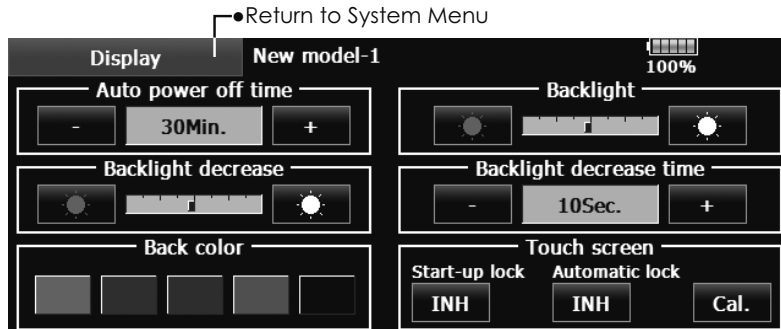

Auto power off time setting

The function to prevent a battery from discharging by failure of the power supply of a transmitter to erase.

1. Adjust the auto power off time with the left and right side buttons.

*When the time the transmitter is inactive reaches the set time, the power is turned off automatically. This time can be set up to 1 hour in 10 minutes increments. The auto power off function can also be deactivated.

*An audible alarm is sounded and an alarm screen is displayed from 3 minutes before auto power off and the time remaining until auto power off is displayed. When a stick or switch is operated while the alarm screen is being displayed, the alarm is cleared and the display is returned to the home screen.

Backlighting brightness adjustment

1. Adjust the backlighting brightness with the left and right side buttons.

*When the right side button is touched, the backlighting becomes brighter. When the left side button is touched, the backlighting becomes darker.

Backlight decrease brightness adjustment

1. Adjust the backlight decrease brightness with the left and right side buttons.

*When the right side button is touched, the backlighting becomes brighter. When the left side button is touched, the backlighting becomes darker.

*It cannot be made brighter than Backlighting brightness adjustment.

Backlight decrease time

You can set a time period to decrease the LCD backlight. This function counts the period that the touch panel has not been operated. This time can be set by ten-second steps. You can also turn off the "backlight decrease" if you like.

*The backlight consumes a large amount of power. We recommend you to turn off the backlight by setting the backlight power-off time to about one minute.

Background color

1. Touch the button of the color you want to change.

*There are five background colors.

Touch screen

[Start-up lock] INH ON, it is touch-panel locked whenever it turns on the power supply of T18MZ-WC. It will be canceled if S2 and S3 key are pushed simultaneously.

[Automatic lock] INH ON, It synchronizes with Backlight decrease time and becomes a panel lock. It will be canceled if S2 and S3 key are pushed simultaneously.

[Cal.] calibration This function adjusts the location of touch panel. Touch "Calibration" button and then press "Yes", the calibration screen will pop up. Touch the center of the cross hair cursor on the screen with the stylus pen. As soon as the system recognizes the position, the cursor will move on to the next position. Repeat this procedure as long as the cursor moves to next position. You will do this five times. Calibration will be carried out based on the five positions. Disappearance of the cross hair cursor means the calibration has been completed. Touch any point on the screen to return to the previous screen.

*In ordinary operation, this calibration is not necessary. If you notice the touch panel is not functioning correctly after long use, we recommend you carry out this calibration.

< System Menu > 55

AIRPLANE

GLIDER

HELICOPTER

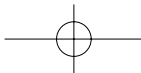

Date and Time

Date and time setting (system clock setting) and integrating timer resetting

This function adjusts the system clock of the T18MZ-WC transmitter. Perform this setting when you purchase the set and when adjustment is necessary.

The integrating timer can also be reset.

*The integrating timer is displayed on the Home screen.

- Touch the [Date and Time] button in the System Menu to call the setup screen shown below.

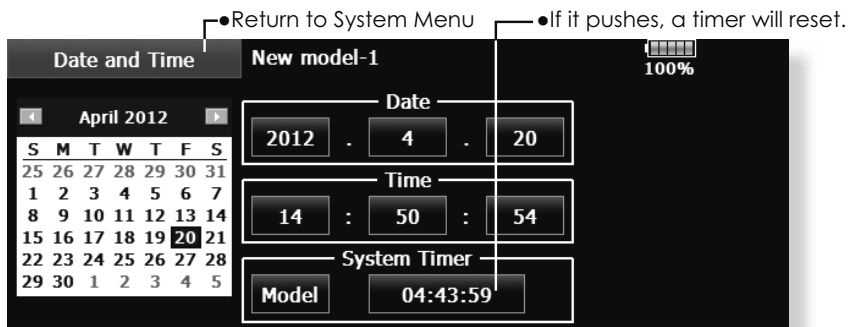

- Total : Regardless of a model, additional time in case a power supply ON is displayed.
- Model : The additional time when the power supply was set to ON is displayed for every model.

AIRPLANE

GLIDER

Date setting

1. Touch the "Year", "Month", or "Day" button and set the date by touching the [+] or [-] button.

*The date can also be set by pressing the date on the calendar shown at the left.

Time setting

1. Touch the "Hour" or "Minute" button, and set the time by touching the [+] or [-] button.
2. When the "Second" button is touched, the timer is set to "00" seconds.

Integrating timer reset

The integrating timer shows the total time that has elapsed since the last "reset".

1. When the [System Timer] button is touched, the timer is reset.

HELICOPTER

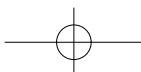

User Name

User name registration and PIN setting

This function registers the T18MZ-WC user name.

A PIN can also be set to protect the set data or user name.

*Set the PIN carefully. When a system PIN is set, if you forget the PIN, none of the settings can be changed. In this case, the system must be reset by the Futaba Service Center.

- Touch the [User Name] button in the System Menu to call the setup screen shown below.

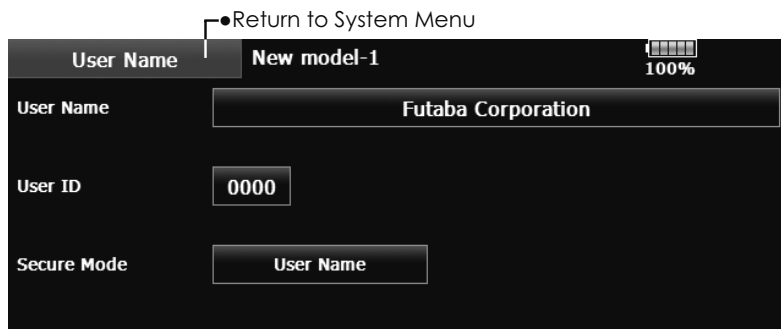

User name registration

1. When the User Name box is touched, a keyboard appears on the screen.
2. Enter the user name from this keyboard.

*A user name of up to 32 characters can be entered.

*The set user name is displayed on the Home screen.

(For a detailed description of the input method, see [User Name Registration/Character Input Method] in the Basic Operation section.)

User name or set data protection

1. Touch the Security Mode button and select the mode. The mode is switched each time the button is touched.

*User Name: Select when you want to protect the user name only.

*System: Select when you want to protect all the set data.

2. When the user ID button is touched, a PIN input screen appears. Input a PIN of up to 4 digits.

3. When the "Return" key is touched, the display returns to the preceding screen.

4. When the transmitter power is turned off, the set security mode becomes active.

*When a PIN is set for the user name, it must be entered the each time the User Name screen is opened.

When a System PIN is set, a button displaying a key icon appears on the Home screen.

When you want to change any settings, touch this button and enter the PIN.

If you want to nullify your current password, set the password to "0000" (default value).

AIRPLANE

GLIDER

HELICOPTER

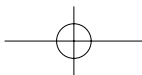

Switch

Toggle switch type setting (Setting when the switch was replaced.)

If you modify the location of the switches on the right and left (top) of the transmitter, you should be sure to re-assign functions to the switches for proper operation.

A "Lock" is included to prevent settings from being modified by mistake. When you need to change settings, unlock this by pressing "Lock". It will then read "Unlock" and you can make changes as required.

- Touch the [Switch] button in the System Menu to call up the setup screen shown below.

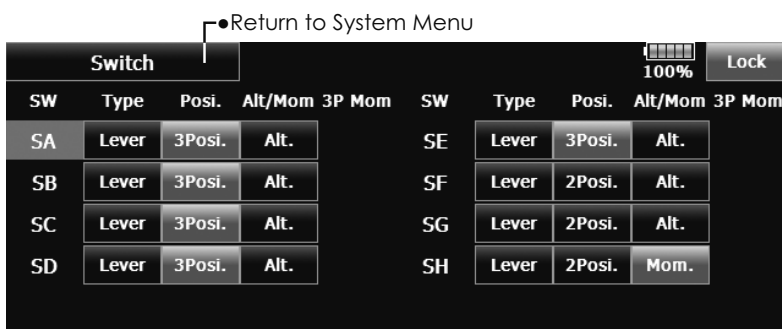

AIRPLANE

GLIDER

Switch selection

1. Select the switch type by touching the [Type] button corresponding to the switch to be replaced.

[Lever]: Toggle switch
 [Button]: Push button
 [Dial]: Knob

- Setting for toggle switch is shown above.

2/3 position selection

1. Touch the "Posi." button corresponding to the switch and select the position type.

[2 Posi]: 2 position
 [3 Posi]: 3 position

[Alt/Mom] mode selection

1. Select the operation mode by touching the [Alt/Mom] button corresponding to the switch.

[Alt.]: Alternate type
 [Mom.]: Self-return type

- Selection of the [Mom.] mode with a 3-position type switch is shown above.

"3P Mom" mode selection

1. Select the operation mode by touching the "3P Mom" button corresponding to the switch.

[Single]: One-side self-return type
 [Dual]: Both directions self-return type

HELICOPTER

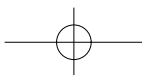

H/W Setting

Stick, switch, trim lever, and knob operation direction reversal (Hardware reverse)/Stick response and hysteresis adjustment (Stick Setting)/Calibration

This function is for adjusting the sticks, switches, and trim characteristics. It is not unless necessary.

H/W Reverse

This function reverses the operation signal of the sticks, switches, trimmer levers, and knobs.

Note: This setting reverses the actual operation signal, but does not change the display of the indicators on the display. Use the Normal mode as long as there is no special reason to use the Reverse mode.

Stick Setting

This function sets the servo response and hysteresis for stick operation for each condition. The control feeling of the stick can be adjusted to match the aerobatics.

Calibration

Usually, this calibration is unnecessary.

Please perform this calibration, only if a change at the center of a stick should arise after prolonged use.

- Touch the [H/W Setting] button at the System Menu to call the setup screen shown below.

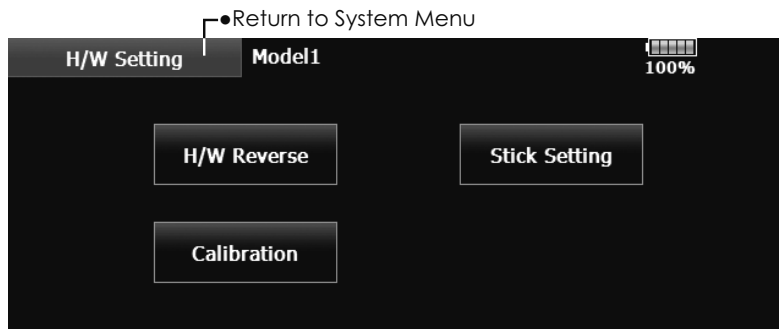

- Touch the [H/W Reverse] button at the H/W Setting Menu to call the setup screen shown below.

H/W Reverse		Model1		H/W		Setting		H/W		Setting	
J1	NORM	T1	NORM	SA	NORM	SE	NORM	LST	NORM		
J2	NORM	T2	NORM	SB	NORM	SF	NORM	LS	NORM		
J3	NORM	T3	NORM	SC	NORM	SG	NORM	LD	NORM		
J4	NORM	T4	NORM	SD	NORM	SH	NORM	RD	NORM		
CD	NORM	T5	NORM					RS	NORM		
CD-SW	NORM	T6	NORM					RST	NORM		

Operation direction reversal method

1. Touch the setting button corresponding to the H/W (Hardware) you want to reverse.
2. Reverse the H/W by touching [Yes]. (When you want to stop operation, touch [No].)
 [Normal]: Normal operation direction
 [Reverse]: Reverses the operation direction.

AIRPLANE

GLIDER

HELICOPTER

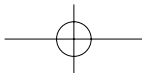

- Touch the [Stick Setting] button at the H/W Setting Menu to call the setup screen shown below.

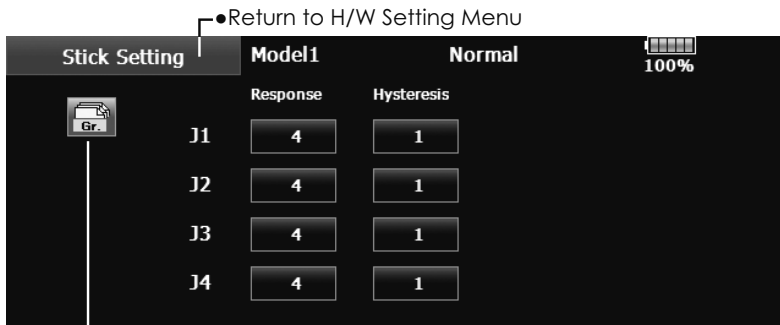

- Group/Single mode switching (Gr./Sngl)
(For more information, see the description at the back of this manual.)

AIRPLANE

Response adjustment

1. Touch the setting button corresponding to the stick with the response you want to adjust. Adjustment buttons appear on the right-hand side of the stick setup screen.
2. Use the adjustment buttons to adjust the response.
Initial value: 4
Adjustment range: 1~16 (When the adjustment value is large, the response becomes slow.)

Hysteresis adjustment

1. Touch the setting button corresponding to the stick whose hysteresis you want to adjust. Adjustment buttons appear on the right-hand side of the stick setup screen.
2. Use the adjustment buttons to adjust the hysteresis.
Initial value: 1
Adjustment range: 0~32 (When the adjustment value is large, the hysteresis value becomes large.)

GLIDER

- Touch the [Calibration] button at the H/W Setting Menu to call the setup screen shown below.

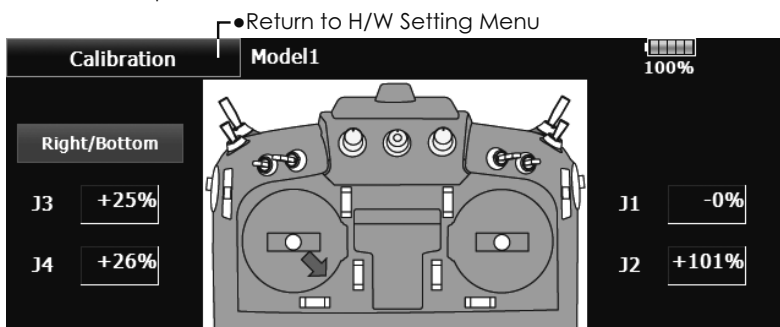

HELICOPTER

How to Calibrate

1. Choose the stick to calibrate right and left.
2. The stick is set at neutral and the [neutral] button is pushed.
3. The stick is held at full right and full bottom (diagonal) the [Right/Bottom] button is pushed.
4. The stick is held at full left and full top (diagonal) the [Left/ Top] button is pushed.

*Please do not press the stick too firmly in any direction when doing the calibration.

*Check after calibration to make sure that neutral is 0% and bottom right side will be +100%, and the top left side is become -100%.

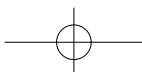

Sound Volume

Sound Volume setting

This function can set the volume of "Key Operation", "Error/Warning", "Trim & Center Click" and "Timer Event" respectively.

*If you have set the PIN try not to forget it. When a system PIN is set, if you forget the PIN, none of the settings can be changed or entered. In this case, the system must be reset by the Futaba Service Center.

- Touch the [Sound Volume] button in the System Menu to call the setup screen shown below.

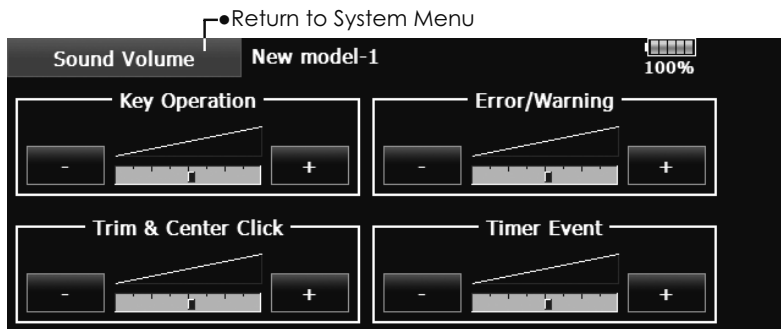

Sound Volume Setting method

1. When the Sound Volume box is touched, the above screen will appear.
2. You can change the sound volume by touching the "+" "-" button of four items.

*If you touch "+", the volume will increase. If you touch the "-", the volume will decrease.

AIRPLANE

GLIDER

HELICOPTER

Player

Music playback

The T18MZ-WC transmitter can play back ".wma" music files stored in your SD card and USB memory. You can listen to them through the built-in speaker or through the headphone jack with your own headphones.

[Important notice]

Before downloading files from your PC into the SD card, insert the SD card into the transmitter and turn on the power of the transmitter. Then the following folders will be automatically created in the SD card. When you download files from you PC, copy and paste the files into their corresponding files.

- BMP : picture files
- WMA : music files
- WAV : sound files
- MODEL : model data files

AIRPLANE

- Push the Music Playback button on the home screen to call the following set-up screen.

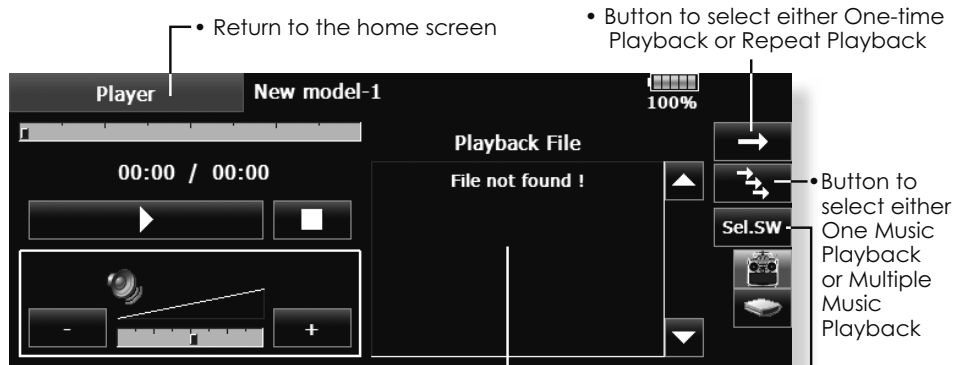

Buttons for music playback

- You can playback any music files listed on the right side of the screen.
- If you adjust the volume here, it adjusts not only music playback but also other applications.

- Button to select either One-time Playback or Repeat Playback

- Button to select either One Music Playback or Multiple Music Playback

- SW selection button
Push this button to call the SW select screen and choose the Music playback switch.
(Refer to the description in the end of this manual)

(Playback file list)

To playback

- All the music files saved in the T18MZ-WC/SD card/USB memory will be shown here.
1. Push the file name to select the music file you want to hear.
 2. Use the buttons on the left to playback or stop the music.

Copy / Delete / Rename

1. Data is chosen from Playback File.
2. Select data file.
3. Copy/Delete or Rename the file.
4. Select [Yes] or [No] to either confirm or deny the changes you wish to do.

GLIDER

HELICOPTER

Camera

Camera photography and picture storage

Pictures can be easily taken with the camera in the T18M-WC. The picture can be saved to the T18MZ-WC, SD card, and USB memory. Your favorite model photographed by you can be displayed on the Home screen, Start screen, and Model Select screen.

- Call the following setting screen by pressing the [Camera] button in the System Menu.
- To the thumbnail screen to view all pictures.

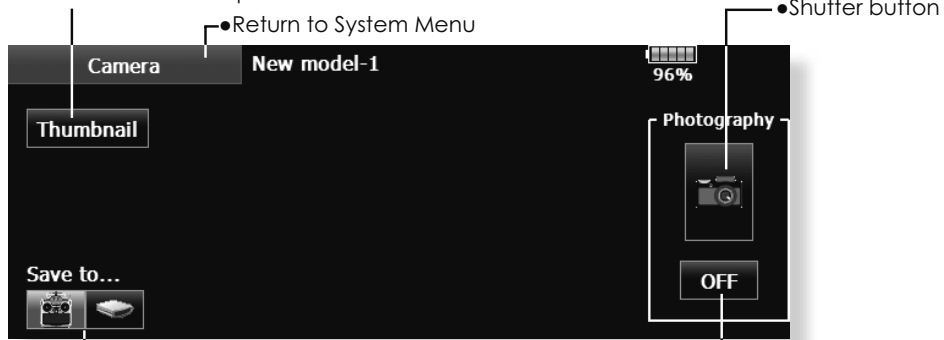

- Picture data save destination (T18MZ-WC, SD card, USB memory)

Shooting method

1. Turn on the transmitter and select [Camera] from the System Menu.
2. Select the picture save destination. (T18MZ-WC, SD card, USB memory)
*Only when an SD card and USB memory are used will an icon be displayed and this choice can be selected.
3. Point the camera at the back of the transmitter toward the subject and press the shutter button.
4. The picture can be checked with the [Thumbnail] button. A picture can be copied and deleted by pressing it.

Copy / Delete / Rename

1. [Thumbnail] button is pushed.
2. Data is chosen from Thumbnail.
3. Copy / Delete / Rename is chosen from a right display.
4. Next, it chooses in [Yes] and [No]. In Rename, name is inputted into the keyboard which appeared, and, finally it pushes Enter.

- Selection of the shutter SW If this is pushed, it becomes SW selection screen and can choose SW of a shutter. ON position of selected SW is set up. In NULL, only the icon of a camera serves as a shutter.

Display pictures at the model data

1. Select [Camera] from the System Menu.
2. Make the save destination the same place as model data. If an SD card or USB memory is not connected, the T18MZ-WC becomes the initial state.
3. Take the picture you want to display with the T18MZ-WC.
(Position the picture inside the frame.)
4. Select the model whose picture you want to paste beforehand.
5. Press [Thumbnail] and then press the picture you took earlier.
6. Press [Entry].
7. The message "Sure?" is displayed. Press [Yes].



< System Menu > 63

AIRPLANE

GLIDER

HELICOPTER

S.BUS Servo

S.BUS servo setting

An S.BUS servo can memorize the channel and various settings itself. Servo setting can be performed on the T18MZ-WC screen by wiring the servo as shown in the figure.

•Servo ID number

Individual ID numbers are memorized for your S.BUS servos in your T18MZ-WC. When a servo is used (as shown at the right), the servo ID number is automatically read by the transmitter.

If you use multiple S.BUS servos and do not want to change the settings on all that are mounted in a fuselage, only the desired servo in the group can be set by entering the ID of that specific servo.

- * S9070SB cannot be arranged by T18MZ-WC.
- * With S.BUS servos of use, there are a function which can be used, and an impossible function and a display screen changes.
(Only the function which can be used by a servo is displayed.)

- Call the following setting screen by pressing the [S.BUS Servo] button in the System Menu.

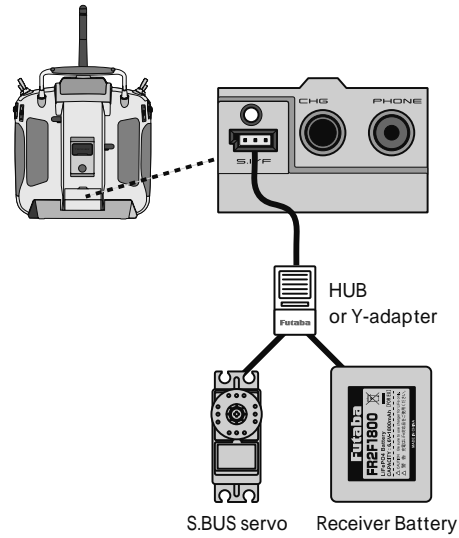

* After reading completion, with connection of the above figure, if a stick is moved, the test of operation of the servo can be operated and carried out.

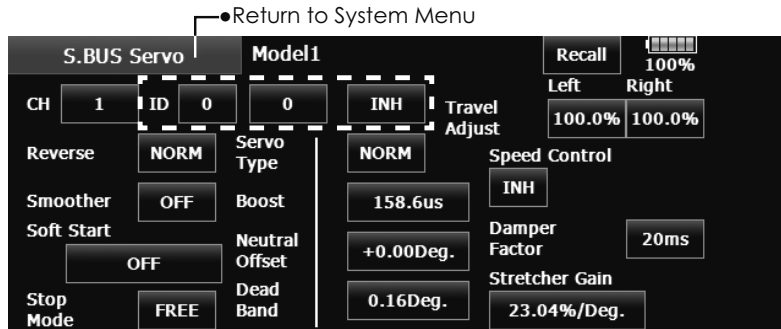

Procedure for changing S.BUS servo setting

1. Select [S.BUS Servo] of the System Menu.
2. Wire the servo as shown in the figure above.
3. Press [Recall]. The ID and current setting of that servo are displayed.
4. When multiple servos are connected change [INH] at the right side of the ID number on the screen to [ACT] and enter the ID of the servo you want to set.
5. Set each item. (Please see the next page.)
6. Press [Write]. The settings are changed.

Servo ID input example

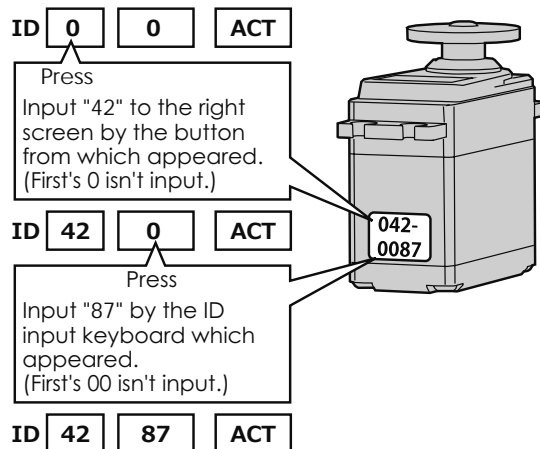

⚠ WARNING

! While S.BUS servo writes, you aren't supposed to remove a connection of a servo and turn off a power supply of a transmitter.

*Data of S.BUS servo is damaged and breaks down.

S.BUS Servo Description of function of each parameter

*There are functions which can be used according to the kind of servo, and an impossible function.

- **ID**

Displays the ID of the servo whose parameters are to be read. It cannot be changed.

- **Channel**

Channel of the S.BUS system assigned to the servo. Always assign a channel before use.

- **Reverse**

The direction in which the servo rotates can be changed.

- **Servo type**

Normal: Normal operation mode

Retract: Landing gear retract mode. When a load is applied to the servo for 30 seconds without any channel operation performed from the transmitter, the current consumption is suppressed by widening the dead band to 40°. When channel operation is performed from the transmitter, or the servo is moved outside the expanded dead band by an outside force, dead band expansion is reset and returns to the original operation.

O.L.P. : This is the Over Load Protection mode. When a servo horn has been locked for more than 5 seconds by a load, the servo output turns off to protect the servo.

* The normal mode and retract mode are applicable only to the S3171SB, S9071SB, S9072SB, S9074SB, and S9075SB

- **Soft Start**

Restricts operation in the specified direction the instant the power is turned on. By using this setting, the first initial movement when the power is turned on slowly moves the servo to the specified position.

- **Stop Mode**

The state of the servo when the servo input signal is lost can be specified. The "Hold" mode setting holds the servo in its last commanded position even if using AM or FM system.

- **Smoother**

This function changes smoothness of the servo operation relative to stick movement changes. Smooth setting is used for normal flight. Select the "OFF" mode when quick operation is necessary such as 3D.

- **Neutral Offset**

The neutral position can be changed. When the neutral offset is large value, the servo's range of travel is restricted on one side.

- **Speed Control**

Speeds can be matched by specifying the operating speed. The speed of multiple servos can be matched without being affected by motor fluctuations. This is effective for load torques below the maximum torque.

However, note that the maximum speed will not exceed what the servo is capable of even if the servos operating voltage is increased.

- **Dead band**

The dead band angle at stopping can be specified.

[Relationship between dead band set value and servo operation]

Small → Dead band angle is small and the servo is immediately operated by a small signal change.

Large → Dead band angle is large and the servo does not operate at small signal changes.

(Note) If the dead band angle is too small, the servo will operate continuously and the current consumption will increase and the life of the servo will be shortened.

- **Travel Adjust**

The left and right travels centered about the neutral position can be set independently.

AIRPLANE

GLIDER

HELICOPTER

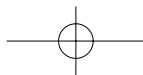

• Boost

The minimum current applied to the internal motor when starting the servo can be set. Since a small travel does not start the motor, it essentially feels like the dead band was expanded. The motor can be immediately started by adjusting the minimum current which can start the motor.

[Relationship between boost set value and servo operation]

Small → Motor reacts to a minute current and operation becomes smooth.

Large → Initial response improves and output torque increases. However, if the torque is too large, operation will become rough.

• Boost ON/OFF

OFF : It is the boost ON at the time of low-speed operation.(In the case of usual)

ON : It is always the boost ON.(When quick operation is hope)

• Damper

The characteristic when the servo is stopped can be set.

When smaller than the standard value, the characteristic becomes an overshoot characteristic. If the value is larger than the standard value, the brake is applied before the stop position.

Especially, when a large load is applied, overshoot, etc. are suppressed by inertia and hunting may occur, depending on the conditions. If hunting (phenomena which cause the servo to oscillate) occurs even though the Dead Band, Stretcher, Boost and other parameters are suitable, adjust this parameter to a value larger than the initial value.

[Relationship between damper set value and servo operation]

Small → When you want to overshoot. Set so that hunting does not occur.

Large → When you want to operate so that braking is not applied. However, it will feel like the servo response has worsened.

(Note) If used in the hunting state, not only will the current consumption increase, but the life of the servo will also be shortened.

• Stretcher

The servo hold characteristic can be set. The torque which attempts to return the servo to the target position when the current servo position has deviated from the target position can be adjusted.

This is used when stopping hunting, etc., but the holding characteristic changes as shown below.

[Relationship between stretcher and servo operation]

Small → Servo holding force becomes weaker.

Large → Servo holding force becomes stronger.

(Note) When this parameter is large, the current consumption increases.

• Buzzer

When the power supply of a servo is previously turned on at the time of a power supply injection without taking transmit of a transmitter, the buzzer sound of about 2.5 Hz continues sounding from a servo.

(Even when the transmit of a transmitter is taken out previously, a buzzer sounds until the signal of a servo is outputted normally, but it is not unusual.)

The transmitter has been turned OFF ahead of a servo power supply The buzzer sound of about 1.25 Hz continues sounding as servo power supply end failure alarm.

(Do not insert or remove the servo connector while the receiver power is ON. A buzzer may sound by incorrect recognition.)

*Buzzer sound is generated by vibrating the motor of a servo.

Since current is consumed and a servo generates heat, please do not operate the number more than needed or do not continue sounding a buzzer for a long time.

AIRPLANE

GLIDER

HELICOPTER

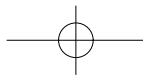

Information

The program version, CF card/USB memory data, and product ID are displayed. The language used by the system can also be changed.

The Information screen displays the T18MZ-WC system program version information, T18MZ-WC, SD card and USB memory (memory size, vacant capacity, number of model data, and number of music files) information and product ID.

*When an SD card and USB memory are not inserted, their information is not displayed.

- Touch the [Information] button at the System Menu to call the setup screen shown below.

Return to System Menu

Information		New model-1		
Transmitter ID	113000036	Internal memory	SD Card	USB Memory
Area	America	Memory Size	92 MB	121 MB
		Free Space	51 MB	98 MB
		Model data	400 models	702 models
				0 model
Language	English	Version		
		WindowsCE	Ver. 6.0 (0)	
		Editor	Ver. 1.100.0	
		Encoder	Ver. 1.100	

AIRPLANE

GLIDER

HELICOPTER

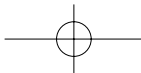

Unit System

The unit of the numerical value displayed by a telemetry can be chosen as one of the metric system and the yard-pound systems.

► Metric

Distance	m	meter
Altitude	m	meter
Speed	km/h	kilometers per hour
Variometer	m/s	meters per second
Temperature	°C	degrees Celsius
Atmospheric pressure	hPa	hectopascal

► Yard-pound

Distance	yd	yard
Altitude	ft	foot
Speed	mph	miles per hour
Variometer	fpm	feet per minute
Temperature	°F	degrees Fahrenheit
Atmospheric pressure	inHg	inch of mercury

- Touch the [Unit System] button at the System Menu to call the setup screen shown below.

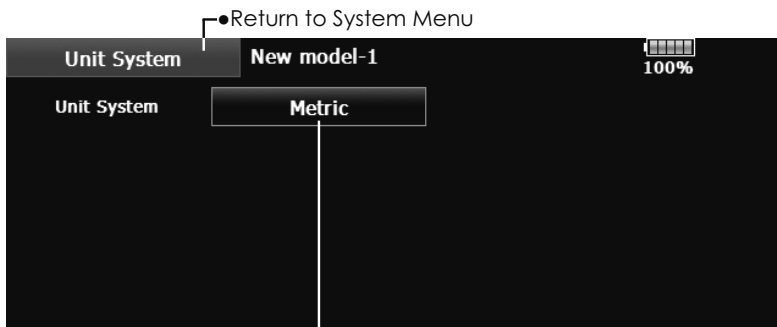

- Touch the [Metric] button. [Metric] [Yard-pound] It chooses. "Sure?" [Yes] push.

AIRPLANE

GLIDER

HELICOPTER

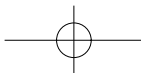

Range Check

Before a flight ground range check.

The 'range check mode' reduces the transmission range of the radio waves to allow for a ground range check.

*The range check mode, when activated, will continue for 90 seconds unless the user exits this mode early. When the progress bar reaches 90 second mark, the RF transmission automatically returns to the normal operating power.

- Pushing [S4]Key is continued. Turn ON the transmitter's power switch [S4]Key will be released if the screen of "Transmit?" comes out.



- [NO] is pushed.

- Touch the [Range Check] button at the System Menu to call the setup screen shown below.

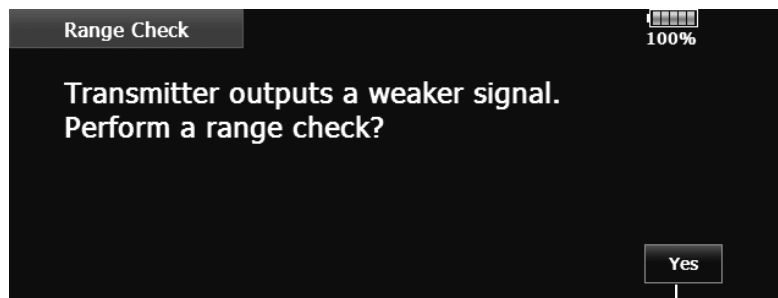

- [Yes] is pushed.

Rotation Range Check method

1. Pushing [S4]Key is continued. →Turn ON the transmitter's power switch. Select [No].
*For safety, the RANGE CHECK mode can not be selected while the RF transmission is active.
2. In the system menu, choose the 'Range Check' selection from the menu options.
3. The Range Check screen is displayed. To activate the Range Check mode press the [Yes] button. During the Range Check period, the RF power is reduced to allow the ground range tests to be performed.
4. The Range Check function automatically exits after the 90 second time limit has expired. The progress bar is displayed on the transmitter's screen. Should you complete the range check before the 90 seconds has pressed, press the [Exit] button.
*When the [RESTART] button is pressed, the range check mode timer is returned to 0.

⚠ WARNING

- ⊘ Do not fly in the range check mode.

*Since the range of the radio waves is short, if the model is too far from the transmitter, control will be lost and the model will crash.

AIRPLANE

GLIDER

HELICOPTER

5. When the [Exit] button is pressed, the Range Check mode is disabled and the 18MZ-WC will begin transmitting at full power.
*Please note, upon expiration of the 90 seconds, or when [Exit] is selected, the transmitter will automatically return to the normal RF operation as noted on the display.
*Once the 18MZ-WC is transmitting at full power, it is not possible to enter the Range Check mode without first switching the transmitter Off and back On. This has been designed to prevent a modeler from inadvertently flying in the Range Check mode.
*After exiting the Range Check mode, the function cannot be selected again. To select the Range Check mode again you must cycle the transmitter power switch.

FUNCTIONS OF LINKAGE MENU

The Linkage Menu has all of the functions you will need to perform model addition, model type selection, frequency setting, end point setting, and other model basic settings.

The functions which can be selected depend on which model type you are using. A typical menu screen is shown below.

- When you touch the Linkage Menu button on the home screen, the menu shown below is called up. Touch the button of the function you want to set.

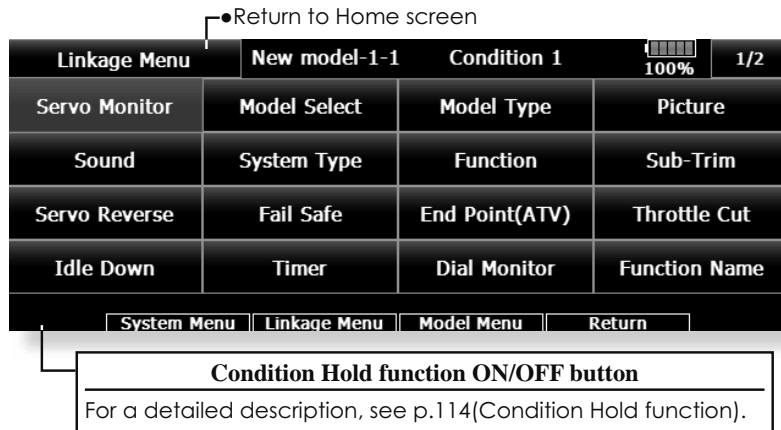

Linkage Menu functions table

- **Servo Monitor** : Displays the servo test and operation position
- **Model Select** : Model addition, call, deletion, copy, model name setting
- **Model Type** : Model type, wing type, switch type, etc. selection
- **Picture** : Picture selection and setting for each model
- **Sound** : Sound recording and playback
- **System Type** : System selection, receiver link, telemetry.
- **Function** : Channel assignment of each function can be changed
- **Sub-Trim** : Adjusts the neutral position of each servo
- **Servo Reverse** : Servo direction reversal
- **Fail Safe** : Fail safe function and battery fail safe function setting
- **End Point (ATV)** : Servo basic rudder adjustment and limit setting
- **Throttle Cut** : Stops the engine safely and easily (airplane and helicopter only)
- **Idle Down** : Lowers the idle speed of the engine (airplane and helicopter only)
- **Swash Ring** : Limits the swash travel within a fixed range to prevent linkage damage (helicopter only)
- **Swash** : Swash AFR and linkage correction function (helicopter only)
- **Timer** : Timer setting and lap time display
- **Dial Monitor** : Dial, slider, and digital trim position display and setting
- **Function Name** : Function Name can be changed
- **Telemetry** : Displays various data sent from the receiver
- **Sensor** : Various telemetry sensors setting
- **Sensor Name** : Change of a sensor name
- **Telemetry Setting** : Data logging of telemetry
- **Warning** : Warning sound and vibration setting
- **Data Reset** : Model memory data reset (by various item)

Servo Monitor

Servo Test & Graph Display / Displays servo positions.

This is used for testing servo movement. Touch “Moving Test” (repetition mode) or “Neutral Test” (fixed position mode) depending on which one shows on the screen. To get from one to the other, simply touch the field again, and you will move from

“Moving Test” to “Neutral Test” automatically. Next touch the “Test” on/off button to start testing your servos. The “Neutral test” is good for finding the neutral position of a servo horn.

- Touch the [Servo Monitor] button in the Linkage Menu to call the setup screen shown below.

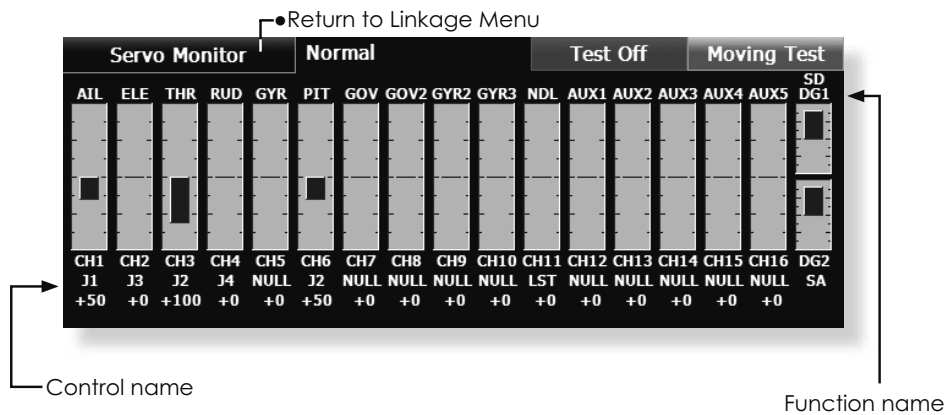

Servo test operation

1. Select a test mode ([Moving] or [Neutral]).
[Repeat]: Each servo repeats operation.
[Neutral]: Each servo is locked in the neutral position.
2. When the [Test Off] button is touched, testing begins in the selected mode.

⚠ WARNING

- ⊘ Don't set a servo test mode when the drive motor is connected and the engine was started.
Inadvertent rotation of the motor or acceleration of the engine is extremely dangerous.

Model Select

The Model Selection function performs model addition, selection, deletion, copy, and model name setting.

This function is used to load the settings of the desired model into the T18MZ-WC's memory.

The settings may be selected from either the transmitter's built-in memory or a SD card/USB memory. The name of the model stored in the transmitter and the SD card/USB memory may be changed. This can be very useful to tell different models settings apart. Each model name can be as long as 32 characters, and the model name always

appears in the display screen.

The Copy function is used to copy one set of model data into a second memory within the transmitter and the SD card/USB memory. It may be used for getting a head-start on setting up models with almost the same settings (only differences need to be modified, instead of entering the complete model from scratch). Also, this function may be used to make a backup copy of a model setup before any changes are made.

- Touch the [Model Select] button in the Linkage Menu to call the setup screen shown below.
- Check mark

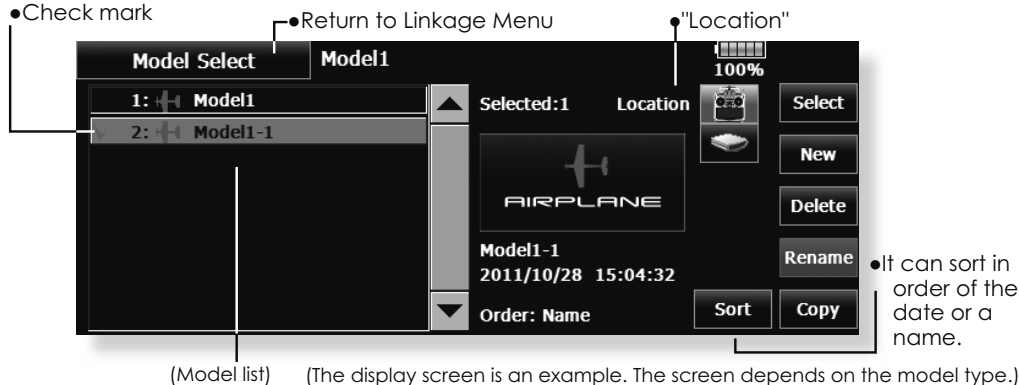

(Model list) (The display screen is an example. The screen depends on the model type.)

Model call

1. Touch the "Location" icon, and select the location to which the desired model is to be saved.
Transmitter icon: Transmitter memory
SD card icon: SD card
USB memory icon: USB memory
2. Touch the desired model in the model list.
3. Touch the [Select] button.
4. Touch [Yes] to call the model. (When you want to cancel model call, press [No].)

Model addition

1. Touch the [New] button.
2. Touch [Yes] to add the model. (When you want to cancel model addition, touch [No].)
*When a new model is added, the Model Type screen is automatically displayed. Check or change the model. If there are no changes, touch the Model Type icons.
*The added model is displayed in the model list.
*When Model addition, a link with a receiver is required. When not relinking, a new model can't use telemetry.

Model deletion

1. Touch the "Location" icon or the model you want to delete in the model list. (The model currently selected cannot be deleted.)
2. Touch the [Delete] button.
3. Touch [Yes]. (When you want to stop model deletion, touch [No].)

Model name change

1. Select the model by touching the "Location" icon or the desired model in the model list.
2. When [Rename] is touched, a keyboard appears on the screen.
3. Enter the model name from this keyboard.
*Up to 32 characters can be input at the model name.

Model copy

1. Select a model to copy from the list.
2. Check mark is attached to the model and a "Copy" button is displayed on the right.
3. Touch the "Copy" button and touch the "Destination" button and select the copy storage destination. (Transmitter or SD card/USB memory)
4. Touch the center [Copy] button.
5. When [Yes] is touched, copying is executed. (When you want to cancel copying, touch [No].)
*If there is no model with the same name in the copy destination, the name of the copied model is saved. If there is a model of the same name, a number is added at the end of the model name and the model is copied. You can change the name later.
*When the model data is copied, the model date is reset to the date that the copy was done.

AIRPLANE

GLIDER

HELICOPTER

Model Type

This function allows you to select the model type from among airplane, helicopter, and glider.

Seven types of main wings and three types of tail wings are available for airplanes. Eight swash types are available for helicopters. Seven types of main wings and three types of tail wings are available for gliders. Functions and mixing necessary for each model type are set in advance at the factory.

Note: The Model Type function automatically selects the optimal output channels, control functions, and mixing functions for the chosen model type. When the Model Type Selection is accessed, all of settings in the active model are cleared. Be sure that you don't mind losing this data, or back it up to memory using the copying functions.

- Touch the [Model Type] button in the Linkage Menu to call the setup screen shown below.

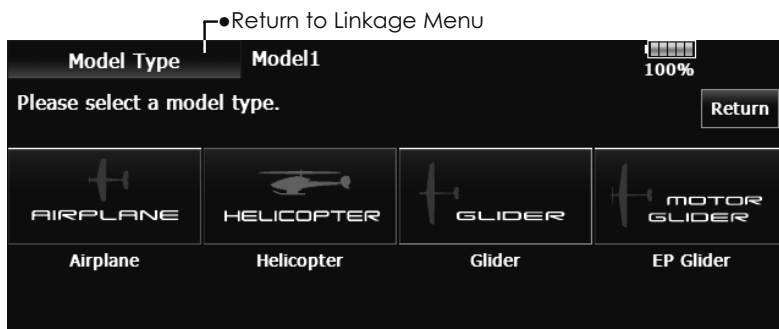

(The display screen is an example. The screen depends on the model type.)

Model type selection

1. Set the Model type, Wing type, Tail type, or Swash type by using the appropriate button.
2. Set the type you choose by touching [Yes] at the confirmation screen. (When you want to cancel model type selection, touch [No].)

Date changes after a swash type change

Data that has been set may change if the swash type of your helicopter is changed.

(Refer to the following table) When data is changed the [swash setting] screen is initialized.

Before	After	Data taking over
H-1, H-2, HE3, HR3, HN3, H-3	H-1, H-2, HE3, HR3, HN3, H-3	OK
H-4, H-4X	H-4, H-4X	OK
H-1, H-2, HE3, HR3, HN3, H-3	H-4, H-4X	NG
H-4, H-4X	H-1, H-2, HE3, HR3, HN3, H-3	NG

- When a data change will occur, the confirmation screen of data initialization menu will be displayed. A push on [yes] will initialize data and allow changes. A push on [no] will stop data changes.

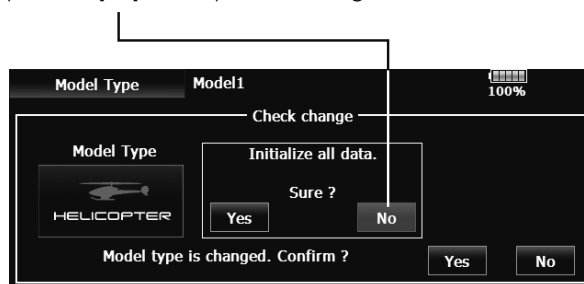

• Model type selection



Model type
Select the model type from among airplane, helicopter, glider, and motor glider.

(Airplane, glider)

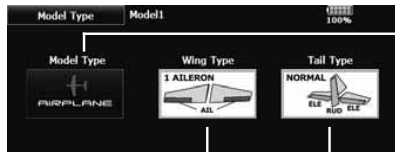

(Helicopter)

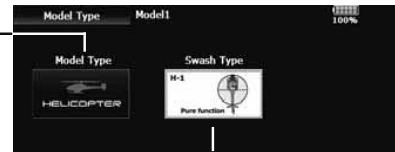

• Wing type selection (1/2)

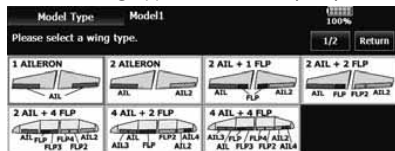

• Swash type selection

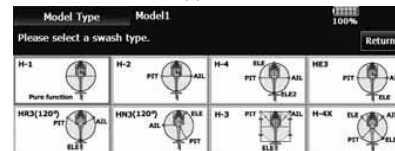

Helicopter swash type
Select from among H-1, H-2, H-4, HE3, HR3, HN3, H-3, and H-4X.

• Wing type selection (2/2)

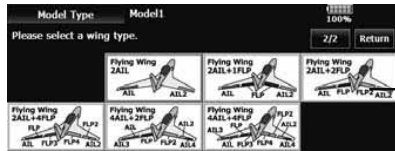

• Rudder type selection



• Tail type selection

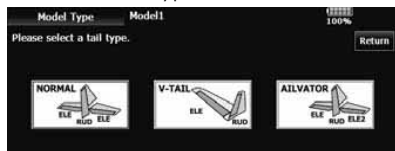

Wing type (1/2) (Normal)
Select from among :
1 aileron, 2 ailerons, 2 ailerons + 1 flap,
2 ailerons + 2 flaps, 2 ailerons + 4 flaps,
4 ailerons + 2 flaps, 4 ailerons + 4 flaps.

Wing type (2/2) (Tail-less wing)
Selection from among:
2 ailerons, 2 ailerons + 1 flap,
2 ailerons + 2 flaps, 2 ailerons + 4 flaps,
4 ailerons + 2 flaps, 4 ailerons + 4 flaps.
*For Tail-less wing, the rudder type can be selected from normal rudder and winglet.

Tail type
Select from normal, V tail, and elevator.

AIRPLANE

GLIDER

HELICOPTER

Picture

A picture on the home screen can be set for each model. (Simplifies identification of the model data during screen operation.)

A photograph of the model taken with a T18MZ-WC camera, digital camera or other file can be pasted as the screen display data for each model. This is convenient in identifying models with the same model name.

When a picture is pasted, it is displayed as a screen image in the following screens:

- Model Select screen
- Home screen
- Startup screen

*The picture files which can be displayed on the screen are size 168 x 80 pixels, file type .bmp (bit map picture) and JPEG files. If a file larger than 168x80 is used, the picture displayed will be reduced. A larger file than 640x480 pixels cannot be used.

- Touch the [Picture] button in the Linkage Menu to call the setup screen shown below.

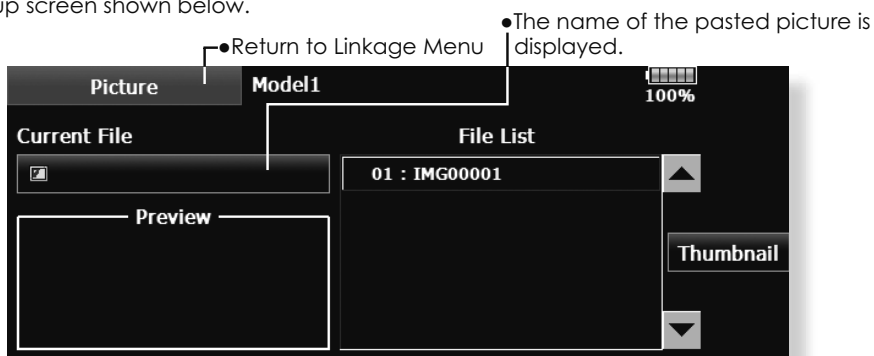

Pasting a picture

*Picture data is set to the model memory currently in use.

*You can choose to use a picture that is saved in these places: T18MZ-WC, SD card, USB memory.

1. Select the picture from the file list by touching the desired picture data.

*Before selection, touch the scroll button at the top or bottom of the Thumbnail and confirm the contents of the picture to be saved by the preview screen.

2. To paste the picture, touch [Yes]. (When you want to cancel pasting, touch [No].)

Copy / Delete / Release / Rename of picture

1. Select the picture from the [Thumbnail] by touching the desired picture data.

2. To paste the picture, touch this screen is displayed.

3. Copy (T18MZ-WC/SD card/USB memory), Delete, Release, Rename or selection.

*Release : It loses from Current File.

Delete : Picture data is deleted.

*Select the picture from the thumbnail, memory card or 18MZ-WC icons you wish to copy for that particular model. Press Enter and exit out to the home page.

4. Next, select [Yes] or [No]. Select Rename to name the picture of your choice with the appeared keyboard. When finished, press Return.

[Important]

Before reading data from the PC, insert the SD card/USB memory into the transmitter and turn on the power. The following folders are automatically written. To read a file from the PC, copy the file to a folder by file type.

•BMP: Picture file	•WAV: Audio file
•WMA: Music file	•MODEL: Model data



AIRPLANE

GLIDER

HELICOPTER

Sound

Sound recording and playback.

Sounds recorded with the microphone built into the transmitter or any audio files (.wav) can be set to the power switch or any preset switch that you choose.

- *Only a .wav file saved in the same storage place (T18MZ-WC, SD card, a USB memory) as the current model can be chosen.
- *The maximum recording time from the microphone is 3 seconds. Twenty-four audio files can be saved.
- *The only audio file type which can be recorded is .wav. Only the sounds recorded with the built-in microphone or an audio file saved from your PC to an SD card can be played back.

Setup screens number 3 to 24 can be individually assigned to audio file switches, etc. The playback files can be switched each time the same switch is operated. This can be used when playing back the name of maneuvers, etc.

[Sound starting]

- # 1: When transmitter power switch turned on
- # 2: When transmitter power switch turned off
- # 3~24: Switch can be set.

[Important]

Before reading data from a PC, insert the SD card/USB memory into the transmitter and turn on the power. The following folders are automatically written. When reading a file from the PC, copy it to a folder by file type.

- BMP: Picture file
- WAV: Audio file
- WMA: Music file
- MODEL: Model data

- Touch the [Sound] button in the Linkage Menu to call the setup screen shown below.

•Return to Linkage Menu

Sound				Model1				100%	1/2
No	Switch	Mode	File	Rec	No	Switch	Mode	File	Rec
1	Start up				7	OFF	→		
2	Power off				8	OFF	→		
3	OFF	→			9	OFF	→		
4	OFF	→			10	OFF	→		
5	OFF	→			11	OFF	→		
6	OFF	→			12	OFF	→		

<Sound>				Model1			
No	Switch	Mode	File	Rec	No	Switch	Mode
1	Start up				7	OFF	→
2	Power off				8	OFF	→
3	OFF	→			9	OFF	→
4	OFF	→			10	OFF	→
5	OFF	→			11	OFF	→
6	OFF	→			12	OFF	→

01 : test.wav

02 : Sound

Copy to T18MZ

Copy to SD Card

Copy to USB Memory

Delete

Entry

Rename

Close

(Saved sound file)

- Touch the file button Copy/Delete/Entry/Rename is made.

It is the same procedure as the picture of the preceding clause.

Voice Recording

1. Touch any REC button to call up the SOUND RECORDER screen.
2. Touch the REC button to start recording. (Recording time: 3 seconds)
3. Record your voice as you are facing the transmitter's microphone.
*Speak loudly and clearly.
4. To finish, press "CLOSE". Also sound files

created by your PC may be played back by assigned switches. (File types: .wav file only)

*A voice file is saved automatically to the location of the model you are currently using. Whether in the transmitter, SD card, or USB memory. A file name is displayed on the file button corresponding to a recording button.

Assignment of audio files to switches

*Audio files can be saved beforehand.



1. Touch the file button of the number you want to set. A list of the files stored is displayed.
2. Select the audio file you want to play back from the list of audio files.











*Since the audio files are played back when the audio file names in the list are touched, the file contents can be checked before assignment.

3. Touch the [File] button to assign the files.
4. (Switches are also selected for number 3~24.)
Touch the [NULL] button to call the switch select screen.

5. Select the switch and its ON direction at the switch select screen.
(For a detailed description of the selection method, see "switch setting method" at the back of this manual.)

Mode button

-  Playing back registered file only once
-  Playing back registered file repeatedly
-  Sequentially playing back registered file each time operated by 1 switch

Sound			New model-1				100%		1/2	
No	Switch	Mode	File	Rec	No	Switch	Mode	File	Rec	
1	Start up		test.wav		7					
2	Power off				8					
3	SG				9					
4					10					
5					11					
6					12					

Sequentially playing back registered file each time operated by 1 switch

This is used when calling the order of maneuvers, etc.

[Setting method]

1. After selecting the switch, press the [→] button. The button display thereafter is switched as shown in the screen above.
2. Assign the audio files in the order in which you want to play them back.

The audio files are played back each time the switch selected by the above setting is turned on.

AIRPLANE

GLIDER

HELICOPTER

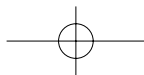

System Type

System mode setting, Receiver link

System Type selection

The T18MZ-WC is for 2.4GHz only. The system can be changed from among 5 choices: FASSTest 18CH, FASSTest 12CH, FASST MULTI, FASST 7CH, S-FHSS, T-FHSS. Select the system matched to the type of receiver you are using.

*Even if it changes a system type, other model data is not reset.

*If a system type is changed in the case of a helicopter, It can choose out of two channel orders.

[Yes] : Selection sets the channel order suitable for system type. (We recommend here.)

[No] : The present channel order is maintained.

*All control surfaces should be checked for the correct operating directions and operating smoothness before flying the model.

*Analog servos cannot be used with the R7008SB in the FASSTest 12CH mode.

Receiver linking

The receiver will only be controlled (without being affected by other transmitters) by the transmitter it is linked to. When using a receiver other than one purchased as a set, linking is necessary.

Moreover, a re-link is required when a new model is added by model selection, and the time of system type change.

Dual receiver function (only FASSTest 18CH mode)

Dual receivers can be linked with the T18MZ-WC. Two receivers are recognized individually by ID numbers. For example, in R7008SB, CH output setting function is used, by setting the first as "1-8CH", and setting the second as "9-

- Touch the [System Type] button in the Linkage Menu to call the setup screen shown below.

16CH", two sets of receivers can be used as a set in the model, allowing you 16 channels. If a dual receiver function is used, the following function can set up individually.

- Battery fail-safe voltage setup

A telemetry function cannot be used for the 2nd receiver. The voltage and Ext voltage of a 2nd receiver cannot be known with a transmitter.

Telemetry function (only FASSTest mode)

To use the telemetry function, set "Telemetry" to "ON".

D/L Interval (only FASSTest mode)

When a telemetry function is enabled, the receiving interval (down-link interval) of sensor data can be changed.

If a D/L interval is increased, the response of the sensor data display becomes slower, but stick response will improve.

Battery fail-safe voltage setup (FASSTest / T-FHSS mode)

The voltage which battery fail-safe activates, can be set when you link. (3.5-8.4V) The receiver memorizes the setting as it was at link.

Suggested setting voltages are as follows.

- 4 cells NiCd or NiMH (Normal: 4.8v) = 3.8 v
- 2 cells LiFe (Normal: 6.6 v) = 6.0 ~ 6.2 v
- 2 cells LiPo (Normal: 7.4 v) = 7.2 ~ 7.4 v

It is a rough reference value.

Since it changes with servos carried in the condition and the model of a battery, please set to your own model in a battery consumption current.

AIRPLANE

GLIDER

HELICOPTER

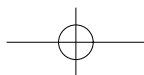
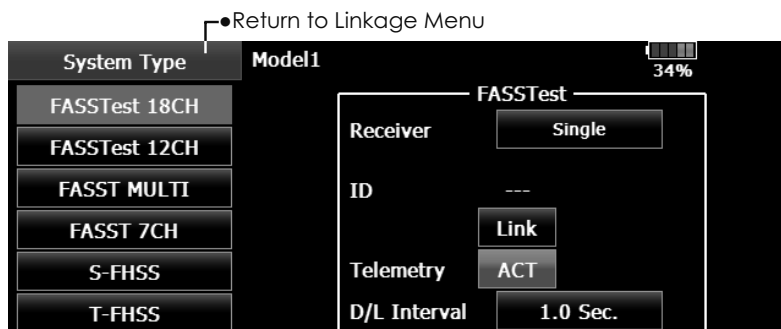

Linking method (T18MZ-WC R7008SB)

1. Bring the receiver to be linked to within 50cm of the transmitter.
2. Press the [Link] button in the [Link] box of [System Type].
3. The transmitter emits a chime sound and enters the link mode.
4. The receiver power is immediately turned on. About 2 seconds after the power is turned on the receiver enters the linking state.
(Receiver linking time is about 1 second)
5. If linking is successful, the receiver LED changes from red to green, the link mode ends, and the receiver ID code is displayed.
6. If linking fails, an error message is displayed. Bring the transmitter closer to the receiver and repeat the procedure above from step 2.

- Touch the [Link] button in the System Type Menu to call the setup screen shown below.

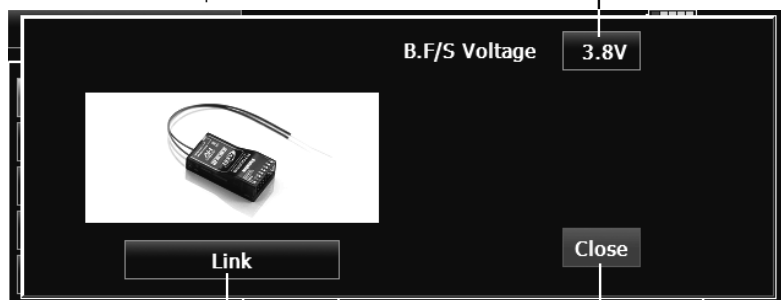

- Battery fail-safe voltage setup (only FASSTest mode)

- Return to System Type Menu

- * Do not perform the linking operation when the drive motor is connected or the engine is running.
- * When you use two receivers, please be sure to setup a "primary" and "secondary" in the "dual" mode.
- * Since two sets of receivers cannot be individually recognized without using a "primary" and "secondary" setup, it is impossible to receive telemetry data correctly.
- * You must link one receiver at a time. If both power supplies to the receivers are switched on simultaneously, data is received incorrectly by the transmitter.
- * A telemetry function cannot be used for the 2nd receiver.
- * You cannot link three sets of receivers.
- * Link is required when a system type is changed.
- * Link is required when a new model is made from a model selection.

AIRPLANE

GLIDER

HELICOPTER

⚠ WARNING

- ⊘ Do not perform the linking operation when the drive motor is connected and the engine was started.
Inadvertent rotation of the motor or acceleration of the engine is extremely dangerous.

- ⚠ Once the link operation is complete, please check that your receiver can be operated with the linked transmitter.

- ⚠ Check operation sufficiently before flying after linking.

If the same receiver is sending in the vicinity, there is the danger that the transmitter may be linked with that receiver.

⚠ CAUTION

- ⚠ Always turn on the transmitter power after linking is complete.
- ⚠ When pairing with the transmitter, be sure that a previously linked transmitter is not transmitting

The example for choosing System Type

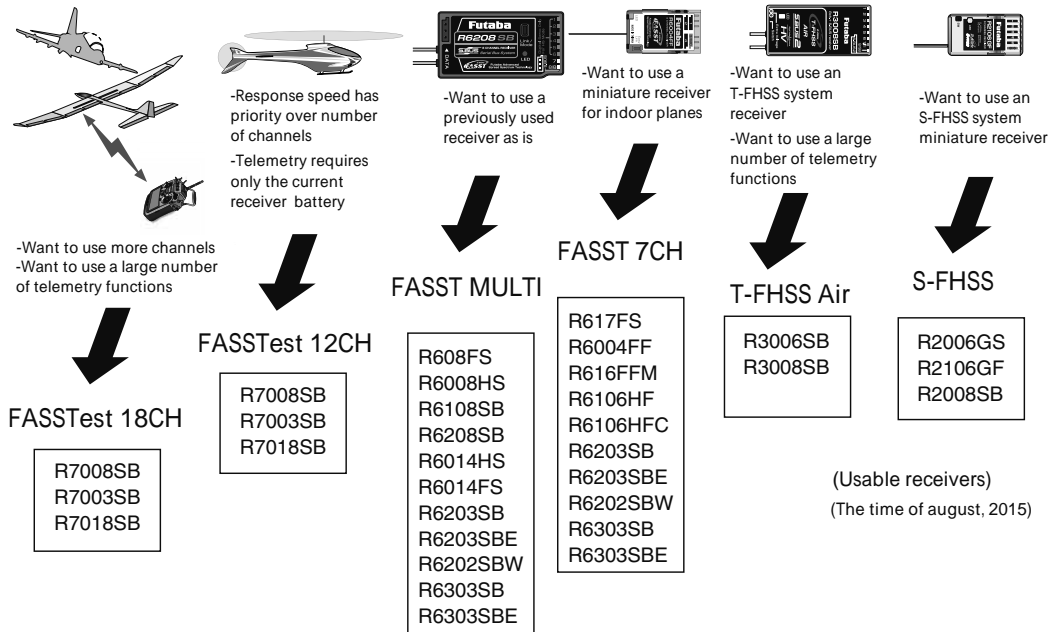

System type

- FASSTest 18CH** --- FASSTest system receiver mode. Applicable with the telemetry sensor unit. Up to 18 channels (linear 16+ON/OFF2) can be used.
- FASSTest 12CH** --- FASSTest system receiver mode. Applicable with receiver voltage display. Up to 12 channels (linear 10+ON/OFF2) can be used. Telemetry Sensor cannot be used, but the response speed is faster than that of the 18CH mode.
- **Analog servos cannot be used with the R7008SB in the FASSTest 12CH mode.**
- FASST MULTI** --- FASST-MULTI system receiver mode. Up to 18 channels (linear 16+ON/OFF2) can be used.
- FASST 7CH** --- FASST-7CH system receiver mode. Up to 7 channels can be used.
- T-FHSS Air** --- T-FHSS system receiver mode. Applicable with the telemetry sensor unit. Up to 18 channels (linear 16+ON/OFF2) can be used.
- S-FHSS** --- S-FHSS system receiver mode. Up to 8 channels can be used.

Receiver link method in FASST and S-FHSS

If the receiver of FASST and S-FHSS is used, the methods of a link differ.

1. Bring the transmitter and the receiver close to each other, within 20 inches (half meter).
2. Turn on the transmitter.
3. Turn on the receiver.
4. Press and hold the Link switch more than two(2) seconds. When the link is complete, the LED in the receiver changes to solid green. When the ID cannot be read due to the surrounding environment, try reading it with the transmitter and receiver antennas touched.

In case of **FASST/S-FHSS**, a **Link button** of the receiver is pressed for a link.



*Follow the manual of the receiver to be used.
Moreover, carry out an operating check.

Function

Channel assignment for each function can be changed to suit your needs.

When you select model and wing (swash) types, you will find that the optimized combinations of servo output channels and functions have been already preset. If you would like, on the function-setting screen of the linkage menu, you can freely change combinations of servo output channels, functions (aileron, elevator, etc), and input controllers (sticks, switches, trim levers and trim switches). You can also assign the same function to multiple servo output channels such as assigning elevator function to CH2 and CH3.

- Touch the [Function] button in the Linkage Menu to call the setup screen shown below.

Return to Linkage Menu

Function				New model-1				Condition 1			
CH	Function	Control	Trim	CH	Function	Control	Trim	CH	Function	Control	Trim
1	Aileron	J1	T1	7	Auxiliary5	NULL	NULL	8	Auxiliary4	NULL	NULL
2	Elevator	J3	T3	9	Auxiliary3	NULL	NULL	10	Auxiliary2	NULL	NULL
3	Throttle	J2	T2	11	Auxiliary1	NULL	NULL	12	Auxiliary1	NULL	NULL
4	Rudder	J4	T4								
5	Gear	SG	NULL								
6	Air Brake	RST	NULL								

(The display screen is an example. The screen depends on the model type.)

Function				New model-1				Condition 1	
CH	Function	Control	Trim	CH	Control				
13	Auxiliary1	NULL	NULL	DG1	SD				
14	Auxiliary1	NULL	NULL	DG2	SA				
15	Auxiliary1	NULL	NULL						
16	Auxiliary1	NULL	NULL						
								SWAP	

•to [SWAP]

Function change

1. Touch the function button of the channel you want to change to call the function list.
2. Select the function you want to change.
3. Touch [Yes]. The display returns to the original screen. (When you want to cancel function change, touch [No].)

*Multiple channels can be assigned to 1 function.

*Multiprop1,2 is an optional object for Multiprop decoders.

<CH which can be Multiprop set up.>

FASSTest 18CH/T-FHSS---1-12CH
 FASSTest 12CH ---not set
 FASST MULTI ---11,12CH
 FASST 7CH ---not set
 S-FHSS ---not set

DG1, DG2 (switch channels)

These two channels can be used as switch (On/Off) channels. You can freely change combinations between servo output channels and input controllers (sticks, switches, trim levers and trim switches).

Channel restrictions by a System Type

FASSTest 18CH/T-FHSS---16 CH+2 Switch
 FASSTest 12CH ---10 CH+2 Switch
 FASST MULTI ---16 CH+2 Switch
 FASST 7CH --- 7 CH
 S-FHSS --- 8 CH

AIRPLANE

GLIDER

HELICOPTER

Operation control change

1. Touch the control button of the channel you want to change. A control select screen (stick, switch, knob, trim lever, etc.) is displayed.
2. Select the control you want to operate.
3. Touch [Close]. The display returns to the preceding screen.

*The same control can be assigned to multiple channels.

AIRPLANE

SWAP

If [SWAP] is pushed, it will call up the following screen. You can easily change two separate functions, keeping the data that was set for each channel.

1. Select the (Trim) button for the two functions you selected to Swap to set up the trims appropriately.
2. If [OK] is pushed, two channels will interchange.

*It can choose only to two.

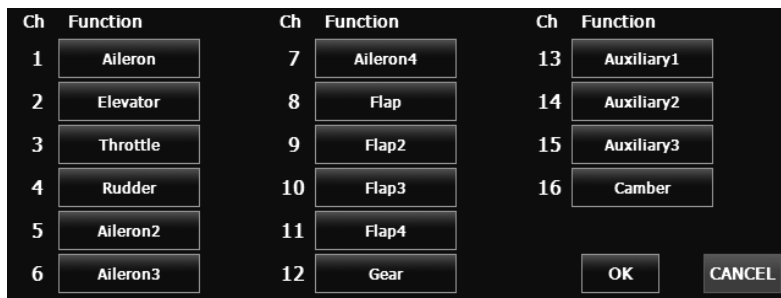

GLIDER

Trim change

1. Touch the trim button to call the trim setup screen.
2. The following items can be set at the trim setup screen.
 - Hardware setting (Selection of switch, etc. which controls trim) (The select screen is called by touching the [H/W Select] button.)
 - Rate setting
 - Operation step setting
 - Trim mode setting
Normal mode: Normal trim (linear) operation

ATL mode: ATL operation mode. (Works at only one end of operation) Reverse is also possible.
 CTRM mode: Maximum change near center by center trim operation (Does not change at end of the stick movement)

- Separate/combination mode: Trim data can be set to different flight conditions
 Separate mode: Trim adjustment for each separate flight condition.

HELICOPTER

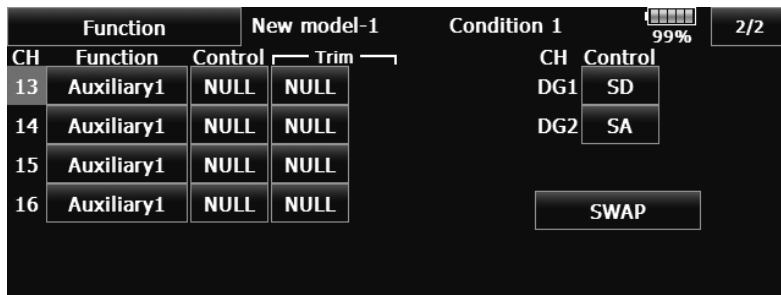

(The display screen is an example. The screen depends on the model type.)

Sub-Trim

Setting of neutral position of each servo.

The Sub-Trim function is used to set the servo neutral position, and may be used to make fine adjustments to the control surface after linkages and pushrods are hooked up. When you begin to set up a model, be sure that the digital trims are set to their center position.

- Touch the [Sub Trim] button in the Linkage Menu to call the setup screen shown below.

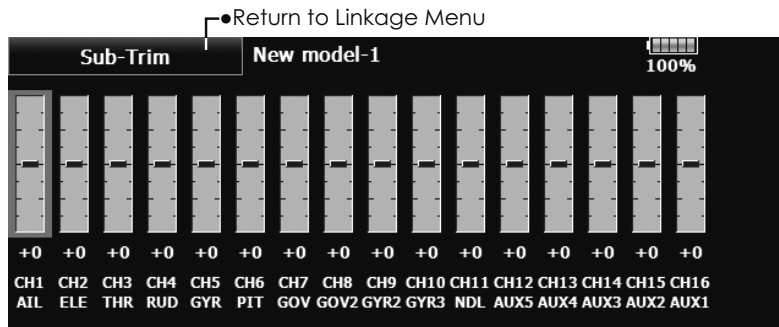

(The display screen is an example. The screen depends on the model type.)

Sub trim adjustment

1. Touch the trim display part of the channel you want to adjust.
Adjustment buttons appears on the Sub Trim menu screen.
2. Use the adjustment buttons to adjust the sub trim.
 - Initial value: 0
 - Adjustment range: -240~+240 (steps)
 - *See above
3. Repeat this step for each channel.

AIRPLANE

GLIDER

HELICOPTER

Servo Reverse

Use to reverse the servo throw direction.

Servo Reverse changes the direction of an individual servo's response to a control stick movement.

For CCPM helicopters, be sure to read the section on Swash AFR before reversing any servos. With CCPM helicopters, always complete your servo reversing prior to any other programming. If you use pre-built Airplane/Glider functions that control multiple servos, it may be confusing to tell whether the servo needs to be reversed or a setting in the function needs to be reversed. See the instructions for each specialized function for further details.

Always check servo direction prior to every flight as an additional precaution to confirm proper model memory, hook ups, and radio function.

⚠ WARNING

❗ Before a flight, always check that your models servo operation, the direction of control surfaces, and switch setup are correct.

❗ Default setting of the motor channel is always reverse.

- Touch the [Servo Reverse] button in the Linkage Menu to call the setup screen shown below.

•Return to Linkage Menu

Servo Reverse			Model1			70%		
CH	Function	Setting	CH	Function	Setting	CH	Function	Setting
1	Aileron	NORM	7	Auxiliary5	NORM	13	Auxiliary1	NORM
2	Elevator	NORM	8	Auxiliary4	NORM	14	Auxiliary1	NORM
3	Throttle	NORM	9	Auxiliary3	NORM	15	Auxiliary1	NORM
4	Rudder	NORM	10	Auxiliary2	NORM	16	Auxiliary1	NORM
5	Gear	NORM	11	Auxiliary1	NORM		DG1	NORM
6	Air Brake	NORM	12	Auxiliary1	NORM		DG2	NORM

(The display screen is an example. The screen depends on the model type.)

Servo reversing procedure

After setting up a new model, be sure to define all special menus. Be sure that all servos are plugged into the proper receiver channels. Now, determine whether you need to reverse any channels by moving each stick and observing the corresponding movement in the model's controls.

1. Touch the desired channel's setting button to choose the proper direction for the servo.
2. Touch "Yes" in the next screen.
3. Repeat for each servo needing reversal.

When done, touch "Servo Reverse" to return to the Linkage Menu.

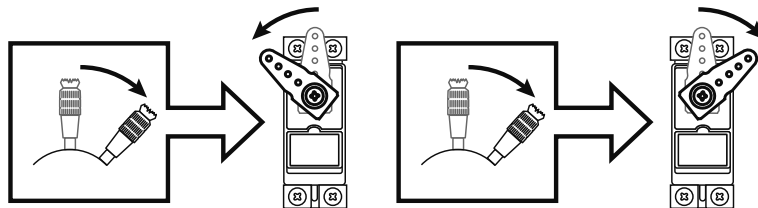

Fail Safe

Sets the servos operating position when transmitter signals can no longer be received or when the receiver battery voltage drops.

The Failsafe function is used to set up positions that the servos will move to in the case of radio interference. Defines servo position when signals are lost and when receiver battery voltage becomes low.

You may set either of two positions for each channel: Hold, where the servo maintains its last commanded position, or fail safe, where each servo moves to a predetermined position. You may choose either mode for each channel.

The T18MZ-WC system also provides you with an advanced battery monitoring function that warns you when the receiver battery has only a little power remaining. In this case, each servo is moved to the defined failsafe position. The battery failsafe may be released by operating a predefined control on the transmitter (default is throttle). **Do not continue to fly, land as soon as possible.** Remember, if the

- Touch the [Fail Safe] button in the Linkage Menu to call the setup screen shown below.

Return to Linkage Menu

Fail Safe			New model-1		99%		Batt. F/S	OFF	1/2
CH	Function	Mode	B.F/S	F/S Posi.	CH	Function	Release Mode	B.F/S	F/S Posi.
1	Aileron	Hold	OFF		7	Auxiliary5	Hold	OFF	
2	Elevator	Hold	OFF		8	Auxiliary4	Hold	OFF	
3	Throttle	Hold	OFF		9	Auxiliary3	Hold	OFF	
4	Rudder	Hold	OFF		10	Auxiliary2	Hold	OFF	
5	Gear	Hold	OFF		11	Auxiliary1	Hold	OFF	
6	Air Brake	Hold	OFF		12	Auxiliary1	Hold	OFF	

To <Switch> screen

(The display screen is an example. The screen depends on the model type.)

Fail safe setting procedure

Decide which channels you want to go to preset positions, and which ones you want to maintain their last commanded position. To select the fail safe mode you wish to set, use the F/S button. This button toggles between the two modes. (Hold, F/S)

F/S mode setting:

1. Touch the F/S button of the channel you want to set, and set that channel to the [F/S] mode.
2. Hold the corresponding stick, control, slider, or other control in the position you want the servo to move to when the fail safe function is activated, and touch the F/S position button. That position is displayed in percentage.

*When you want to return that channel to the Hold mode, touch the [F/S] button again.

Battery fail safe setting procedure

To select the B.F/S mode, touch the [B.F/S] button. Each time the button is touched, it toggles between [OFF] and [B.F/S].

predefined control suddenly moves to a position you did not command, land at once and check your receiver battery.

Do not continue to fly, land as soon as possible. Defines servo position when signals are lost and when receiver battery voltage becomes low.

⚠ WARNING

❗ For safety, always set the fail safe functions.

Especially set the throttle channel fail safe function so that the servo moves to the maximum slow side for airplanes and to the slow side from the hovering position for helicopters. Crashing of the model at full high when normal radio waves cannot be received due to interference, etc., is very dangerous.

If fail safe is reset by throttle stick movement, the fail safe may be mistaken as an engine malfunction and will be reset at low throttle and the model will continue to fly. If you have any doubts, immediately land.

AIRPLANE

GLIDER

HELICOPTER

B.F/S setting:

1. Touch the [B.F/S] button of the desired channel to set it to the B.F/S mode.
2. Hold the corresponding stick, VR, slider, or other control in the position you want the servo to move to when the battery fail safe function is activated, and touch the F/S position button. This position is displayed in percentage.

*When you want to return that channel to OFF, touch the [B.F/S] button again.

Battery Fail safe Release Function

This function releases the predefined control from its held position after indicating that your receiver battery is low.

1. Enter the control setting screen by touching the Battery F/S Release button. Now, you may choose whether moving the throttle resets the condition, or select a stick or switch to deactivate it. To set a desired throttle release position, move the throttle stick to the point at which you wish the B.F/S to be released.

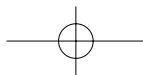

End Point (ATV) Sets the travel, limit point, and speed of each servo.

The End Point function adjusts the left and right servo throws, generates differential throws, and will correct improper linkage settings.

The travel rate (normal full stick movement at high rates) can be varied from 30% to 140% in each direction on channels 1 to 16. Also, the limit point (how far the servo travels when a mix is involved) where servo throw stops may be varied from 0% to 155%.

Note: The indicators on the screen display actual servo throw of the each channel. The center position of the indicator is based on the Sub-Trim settings. Therefore the Sub-Trim adjustment changes the Limit point display of the indicator. The Servo Speed setting is used to set the servo delay for each channel, from channel 1 to channel 16. The system uses the programmed speed (delay) to slow down servo position changes. The Servo Speed setting can be varied from 0 to 27 in each channel.

AIRPLANE

- Touch the [End Point (ATV)] button in the Linkage Menu to call the setup screen shown below.

Return to Linkage Menu

End Point(ATV)		New model-1		99%		1/3		
CH	Function	Limit	Travel	← ↑ ↻	↻ ↓ →	Travel	Limit	Speed
1	Aileron	135%	100%			100%	135%	0
2	Elevator	135%	100%			100%	135%	0
3	Throttle	135%	100%			100%	135%	0
4	Rudder	135%	100%			100%	135%	0
5	Gear	135%	100%			100%	135%	0
6	Air Brake	135%	100%			100%	135%	0

(The display screen is an example. The screen depends on the model type.)

GLIDER

Servo travel adjustment

1. Touch the travel button of the channel you want to set. Adjustment buttons appear on the screen.
2. Use these buttons to adjust the rate.
 - Initial value: 100%
 - Adjustment range: 30%~140%
3. Repeat the procedure above for each rate.

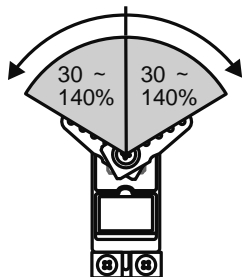

Limit point adjustment

1. Touch the limit button of the channel you want to set.
2. Use the adjustment buttons to adjust the limit point.
 - Initial value: 135%
 - Adjustment range: 0%~155%
3. Repeat this procedure for each limit point.

Servo speed setting

1. Touch the Speed button of the channel you want to set.
2. Use the adjustment buttons to adjust the servo speed.
 - Initial value: 0
 - Adjustment range: 0~27 (steps)
3. Repeat this procedure for each channel.

To close this screen, touch the [End Point (ATV)] button.

HELICOPTER

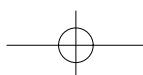

Throttle Cut

Stops the engine safely and easily. (airplane and helicopter only)

Throttle cut provides an easy way to stop the engine, by flipping a switch with the throttle stick at idle. The action is not functional at high throttle to avoid accidental dead sticks. The switch's location and direction must be chosen, as it defaults to NULL.

Note: When conditions are set, at Throttle cut setup can be performed for each condition. Throttle cut can only be activated in a specific condition if you have selected and set up this function within the condition. When using throttle cut in a specific condition, and ON or active. If you change to another condition, throttle cut is canceled and no longer active in the first condition, as long as the second condition does not have throttle cut active.

- Touch the [Throttle Cut] button in the Linkage Menu to call the setup screen shown below.

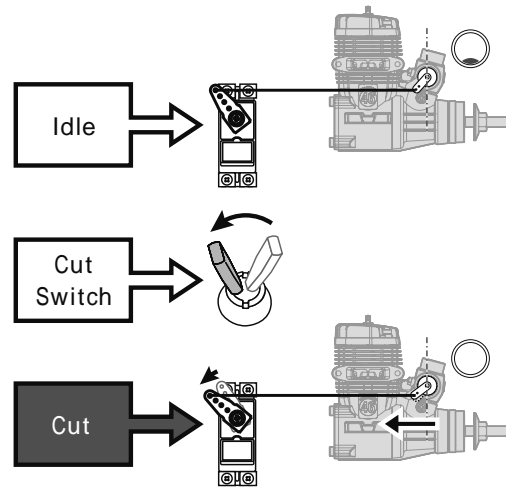

AIRPLANE

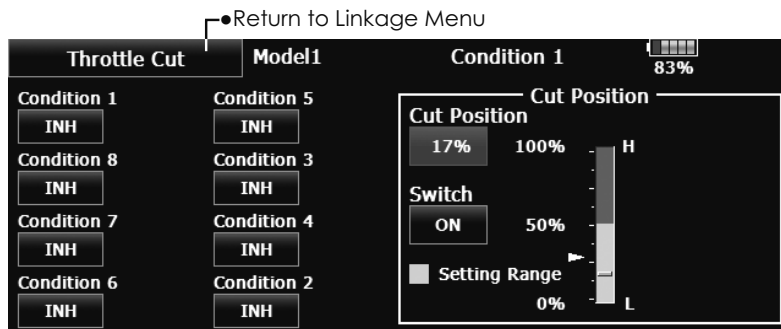

(The display screen is an example. The screen depends on the model type.)

Throttle cut setting procedure

1. To set up throttle cut in conditions, select the condition number and touch the "INH" button.
2. Throttle cut function switch setting:
Touch the "NULL" button to call the <Switch> screen, and then select the switch and its ON direction.
(For a detailed description of the selection method, see [Switch Setting Method] at the back of this manual.)
3. Throttle cut position setting:
Set the throttle stick to maximum slow, and touch the cut Position button. Adjustment buttons appear. At the same time, the numerical value of the current maximum slow side is displayed at "Cut Position".

Use the adjustment buttons to adjust the servo travel when the throttle cut function is activated.

- Initial value: 17%
- Adjustment range: 0%~50%

*With throttle stick at idle, adjust the rate until the engine consistently shuts off, but throttle linkage is not binding. When finished, touch the "Throttle Cut" button to exit.

To exit the setting, touch the [Throttle Cut] button.

HELICOPTER

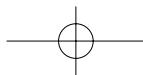

Idle Down

Lowers the engine idling speed. (airplane and helicopter only)

The idle down function lowers the engines idle by flipping a switch with the throttle stick at idle. The action is not functional at high throttle to avoid accidental dead sticks. The switch's location and direction must be chosen, as it defaults to NULL.

AIRPLANE

- Touch the [Idle Down] button in the Linkage Menu to call the setup screen shown below.

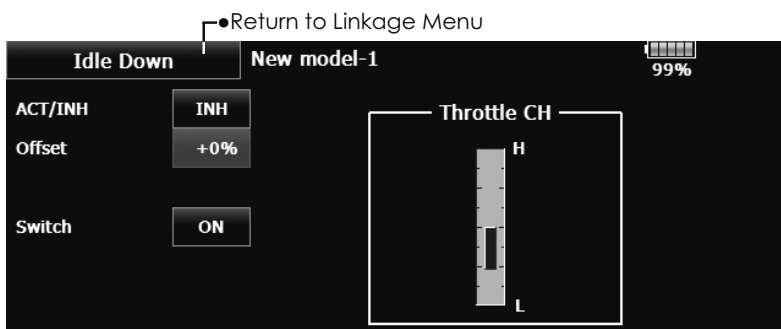

(The display screen is an example. The screen depends on the model type.)

Idle down setting procedure

1. Touch the "INH" button to activate the idle down function.
2. Idle down function switch setting:

Touch the "NULL" button to call the <Switch> screen, and then select the switch and its ON direction.

(For a detailed description of the selection method, see [Switch Setting Method] at the back of this manual.)

3. Offset rate setting:

Touch the offset rate button. Adjustment buttons appear on the screen.

Use these buttons to adjust the offset rate.

- Initial value: 0%
 - Adjustment range: -100%~100%
- *(-)becomes an idle up.

To exit the setting, touch the [Idle Down] button.

HELICOPTER

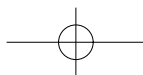

Swash Ring

Limits the swash travel within a fixed range to prevent linkage damage (Helicopter only)

This function limits the travel of the swash plate to prevent linkage damage as the aileron and elevator operation is used. It is useful for 3D heli setting.

- Touch the [Swash Ring] button in the Linkage Menu to call the setup screen shown below.

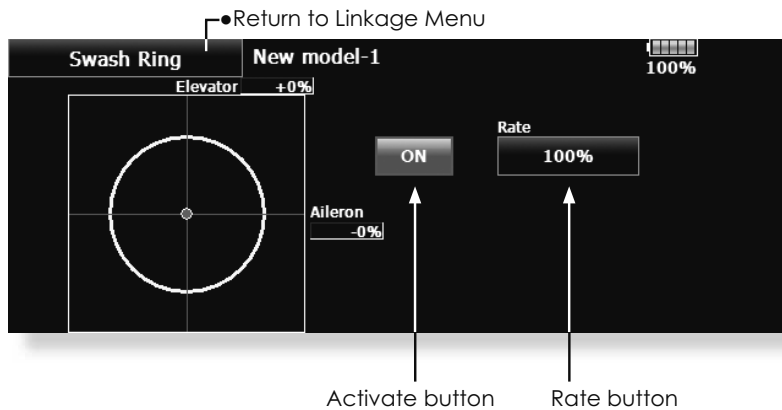

Swash ring setting procedure

1. Push the Swash ring button on the linkage menu.
2. Push ACT/INH button to activate.
 - *The movement area monitor shows the current aileron and elevator values and limit ranges by the yellow circle.
3. Adjust the rate to the maximum amount of swash plate decline.
 - *The swash movement is limited within the circle.
 - Adjustment range: 50 - 200%.

Swash

Swash operation linkage correction function
(This swash setup screen does not appear for swash type H-1.)

Neutral Point

On your linkages, if the servo horn deviates from perpendicular at neutral, the linkage compensation functions may not work effectively. This neutral point setting reads the linkage compensation neutral position. However, this adjustment only changes the reference point of the compensation function on the swash details screen and does not affect the neutral position of other functions.

*Before using the compensation function, set the neutral point.

Swash AFR

The swash AFR function adjusts (increases/decreases/reverse) the rate (travel) of the aileron, elevator, and pitch functions.

Mixing Rate

(Normally, the default value is used.)

This mixing rate is used for minor correction to the swash plate so that it moves in the correct direction for aileron, elevator, and pitch operation.

Compensation mixing is shown below.

*PIT AIL/PIT ELE/AIL PIT/ELE AIL/ELE PIT

*Use the corresponding compensation mixing and adjust so that the swash plate moves in the correct direction.

Linkage Compensation

This compensation mixing is used to adjust for interference when the ailerons or elevators are operated when the throttle stick was in the low or high position.

Speed Compensation

This speed compensation function make adjustments for interference when the travel of each servo is different due to swash plate operation. For HR-3, it compensates the speed by dropping the operating speed of the aileron and pitch servos during elevator operation.

- Touch the [Swash] button in the Linkage Menu to call the setup screen shown below.

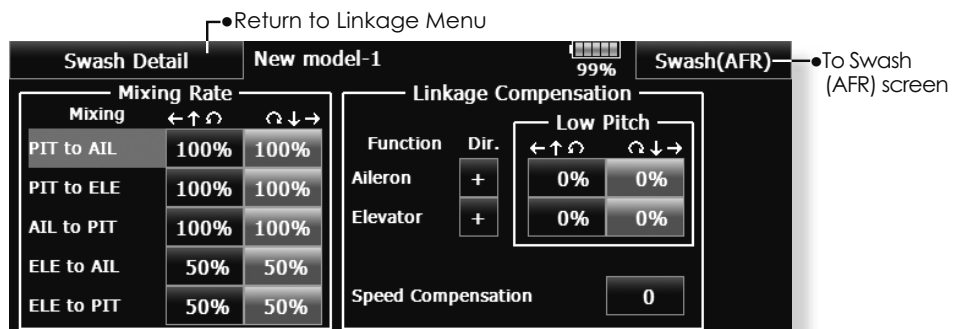
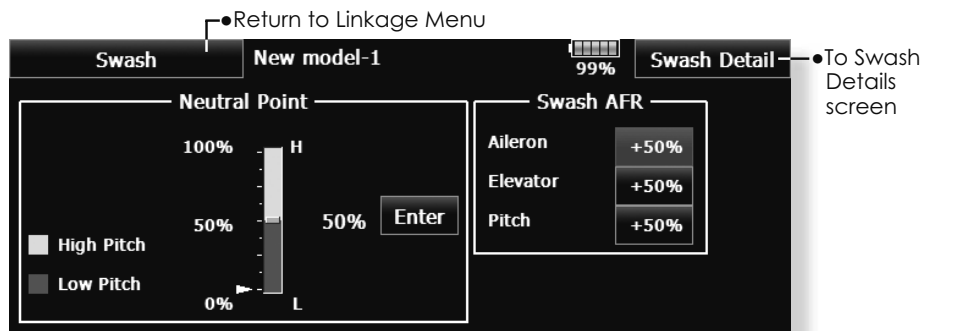

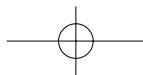

Neutral point setting procedure

*Becomes the compensation reference point.

*Adjusting the servo horn so that the neutral point position is near the 50% position makes the mixing amount small.

1. Hold the servo horn at a right angle to the linkage rod, and then touch the [Enter] button and read the actual neutral point.

*The neutral point is displayed on the screen.

After reading this neutral point, use other compensation functions to make further adjustments.

To exit the setting, touch the [Swash] button.

Swash AFR setting procedure

Adjust so that the specified operation amount is obtained by aileron, elevator, and pitch operation.

1. Touch the button of the AFR rate to be adjusted. Adjustment buttons appear on the screen.
2. Use the adjustment buttons to adjust the AFR rate.

Initial value: +50%

Adjustment range: -100%~+100%

+or- the direction of operation changes.

To exit setting, touch the [Swash] button.

Mixing rate setting procedure

HR-3 is described as an example. The mixing applied in other swash modes is different, but the setting procedure is the same.

1. Set the throttle stick to the set neutral point. Adjust the length of the linkage rod so that the swash plate is horizontal at this position.

*A little adjustment using sub trim should be OK.

*Adjust so that pitch operation when the pitch curve is straight is maximum.

2. Adjust the AIL PIT amount so there is no interference in the elevator or pitch direction when the aileron stick is moved to the left and right.

*Adjust the left and right sides separately.

3. Adjust the ELE AIL and ELE PIT amounts so there is not interference in the aileron or pitch direction when the elevator stick is moved up and down.

*Adjust the up and down sides separately.

4. Adjust the PIT AIL and PIT ELE amounts so that the swash plate is horizontal when the throttle stick is set to maximum slow and full high.

*Adjust the slow and high sides separately.

To exit setting, touch the [Swash Details] button.

Linkage correction setting procedure

*Set the linkage compensation after setting the mixing rate.

*This function compensates for elevator interference by aileron operation or aileron interference by elevator operation at Low pitch and Hi pitch at collective pitch (HR3, etc.) control.

1. Set the throttle stick to the maximum slow position. Move the aileron stick to the left and right and adjust the aileron compensation amount so that interference in the elevator or pitch direction at that time is minimal.

*The left and right sides can be adjusted separately.

*If the interference increases when the compensation amount is increased, make the compensation direction "-".

2. Adjust the elevator compensation amount so that the interference in the aileron or pitch direction when the elevator stick was moved up and down is minimal.

3. Perform aileron and elevator compensation similarly for the throttle stick full high side.

To exit setting, touch the [Swash Details] button.

Speed compensation setting procedure

1. Set the throttle stick to the neutral point position. Move the elevator stick quickly and adjust the speed compensation amount so that the interference in the pitch direction is minimal.

To exit setting, touch the [Swash Details] button.

Note:

If the linkage is too long or short, correct compensation will not be applied. Correct this before continuing. The pitch angle changes after any adjustment. Reset the pitch angle when actually flying after compensation processing.

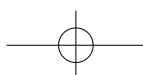

Timer

Timer setting and lap time display.

The Timer function may be set for any desired time, i.e. engine run time, specified times for competitions, etc. Two independent timers are provided for your use. The timers are stored independently with each model, meaning that when you switch between model setups, the timer associated with the new model is brought up automatically.

The timers may be set to start and stop from the motion of any switch or stick. You may set the ON and OFF directions freely. Each timer has a capacity of up to 59 minutes 59 seconds.

- Touch the [Timer] button in the Linkage Menu to call the setup screen shown below.

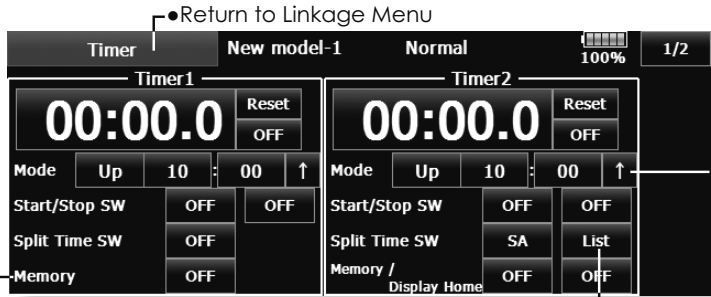

- Memory is turned ON, the power OFF and a model change will not be reset timer, either.

- [↑] An alarm sounds every minute of the elapsed time from timer start. (Conventional mode)
- [↓] An alarm sounds every minute of the remaining time up to the alarm time.

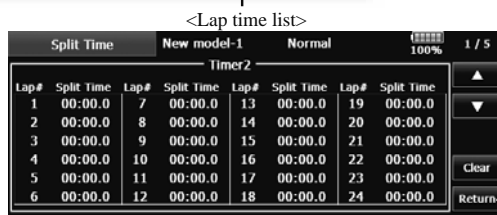

Up timer/Down timer/Hour selection

1. Touch the mode button and select the type of timer.
2. Timer time setting.
Touch the Mode minutes or seconds button. Adjustment buttons appear on the screen. Use these buttons to set the timer time.

Start/SWtop switch setting

1. Touch the Start/Stop SW "NULL" button to call the <Switch> screen, and then select the switch and its ON direction.
(For a detailed description of the selection method, see [Switch Setting Method] at the back of this manual. The timer switches can be set for each condition.)

Lap time switch selection

1. Touch the Lap SW "NULL" button to call the Prog. Mix screen, and then select the switch and its ON direction.
(For a detailed description of the switch setting method, see [Switch Setting Method] at the back of this manual. The timer switches can be set for each condition.)

Each timer may be set for count-down or count up operation with your choice of a target time. Also split time may be set up and counted.

If a target time is set and the timer reaches this point, a buzzer will sound for each count generated.

Countdown timers sound one short beep during the last twenty seconds and two short beeps during the last ten seconds before reaching the target, then a long tone at the target time, and continue counting with displaying a minus (-) sign. Count-up timers also beep the last twenty and ten seconds, beep the target time, and keep counting upwards until shut down.

Timer operation

- Timer 1 and Timer 2 are started and stopped by your choice of switch.
- To count the lap time, select the lap time switch. Each time this switch is operated, the lap time is stored. To display the lap time, touch the respective [List] button.
- To reset a timer, touch the respective [Reset] button. To exit the setting, touch the [Timer] button.

Hour mode

An HOUR mode which counts up to 99 hours 50 minutes has been added to the timer modes.

- This mode is convenient when used at engine maintenance period and other long-term measurements.
- When the HOUR mode is set, "xx(hour) : xx(minute)" is displayed on the count time display. Seconds are not displayed.
- When the HOUR mode is set, ":" blinks each second during timer operation.
- When the HOUR mode is set, the alarm function/lap time measurement function are inhibited.

Vibration

If a set period comes, you will be alerted by vibration.

1. [1/2] is pushed on a timer screen and 2/2 screen is opened.
2. Vibration [OFF] is pushed and it is made [Type1-4]. The kind of vibration is chosen from Type1 to Type4. (The interval of vibration changes.) It can set up separately by the Timer 1 and the Timer 2.

Button Mode

A setup of operation when the timer button in a home screen is pushed.

1. [1/2] is pushed on a timer screen and 2/2 screen is opened.
2. Button mode is chosen from two.

[Setup Screen]

If the timer of a home is pushed, it will jump to a timer set up screen.

[Start/Stop]

If the timer of a home is pushed, A timer performs a start stop directly with a home screen.

- Touch the [Timer] button in the Linkage Menu, and the [1/2] button pushed, call the setup screen shown below.

- [OFF] [Type1-4] If it carries out like this, a vibration function will work.

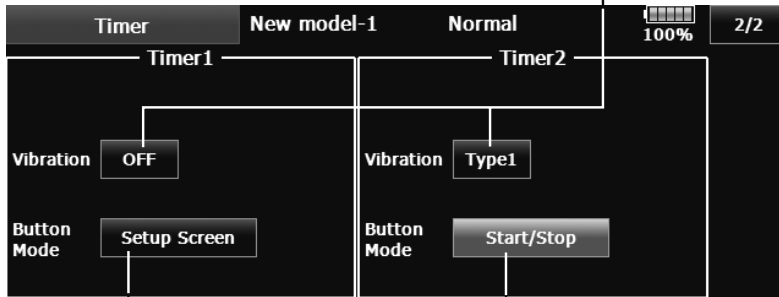

- [Setup Screen]

If the timer of a home is pushed, it will jump to a timer set up screen.

- [Start/Stop]

If the timer of a home is pushed, A timer performs a start stop directly with a home screen.

- Home screen

- Timer 1
- Timer 2

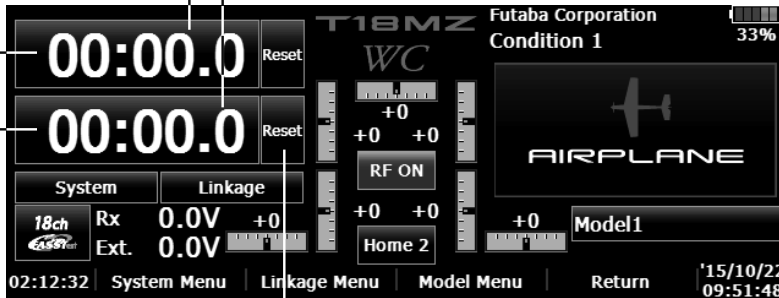

- A time is reset.

AIRPLANE

GLIDER

HELICOPTER