

# T18MZ

18-CHANNEL COMPUTER SYSTEMS

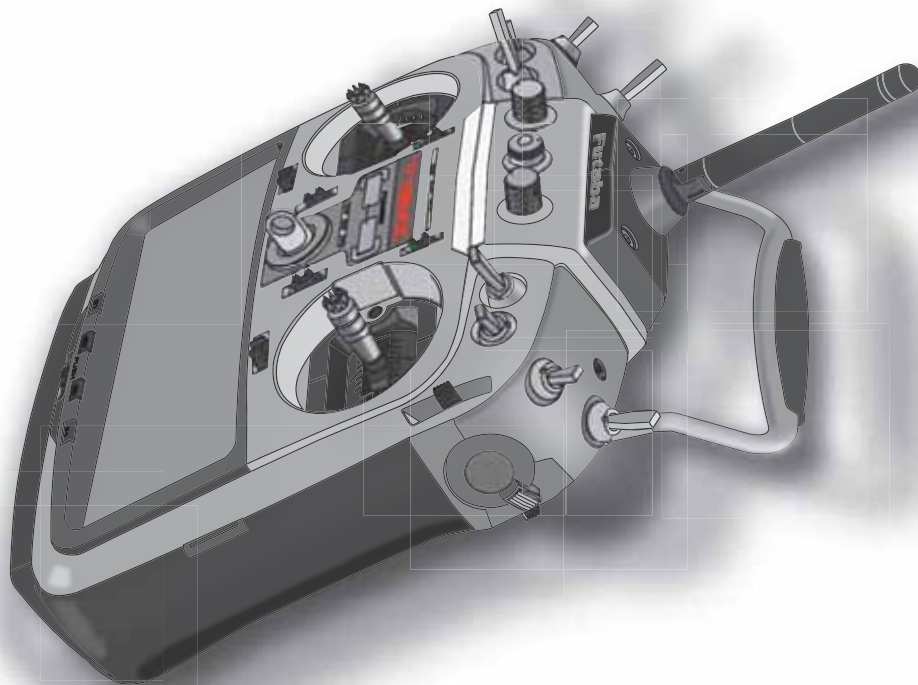

## INSTRUCTION MANUAL

**Futaba**<sup>®</sup>

*Digital Proportional R/C System*



1M23N26403





---

## INTRODUCTION

Thank you for purchasing a Futaba® FASSTest-2.4GHz\* 18MZ series digital proportional R/C system. This system is extremely versatile and may be used by beginners and pros alike. In order for you to make the best use of your system and to fly safely, please read this manual carefully. If you have any difficulties while using your system, please consult the manual, our online Frequently Asked Questions (on the web pages referenced below), your hobby dealer, or the Futaba Service Center.

Due to unforeseen changes in production procedures, the information contained in this manual is subject to change without notice.

Support and Service: It is recommended to have your Futaba equipment serviced annually during your hobby's "off season" to ensure safe operation.

## IN NORTH AMERICA

Please feel free to contact the Futaba Service Center for assistance in operation, use and programming. Please be sure to regularly visit the 18MZ Frequently Asked Questions web site at [www.futaba-rc.com/faq/](http://www.futaba-rc.com/faq/). This page includes extensive programming, use, set up and safety information on the 18MZ radio system and is updated regularly. Any technical updates and US manual corrections will be available on this web page. If you do not find the answers to your questions there, please see the end of our F.A.Q. area for information on contacting us via email for the most rapid and convenient response.

Don't have Internet access? Internet access is available at no charge at most public libraries, schools, and other public resources. We find internet support to be a fabulous reference for many modelers as items can be printed and saved for future reference, and can be accessed at any hour of the day, night, weekend or holiday. If you do not wish to access the internet for information, however, don't worry. Our support teams are available Monday through Friday 8-5 Central time to assist you.

### **FOR SERVICE ONLY:**

Futaba Service Center  
3002 N. Apollo Drive, Suite 1  
Champaign, IL 61822  
Phone: 217-398-0007  
[www.futaba-rc.com/service.html](http://www.futaba-rc.com/service.html)  
Email: [service@futaba-rc.com](mailto:service@futaba-rc.com)

### **FOR SUPPORT :**

#### **(PROGRAMMING AND USER QUESTIONS)**

Please start here for answers to most questions:

[www.futaba-rc.com/faq/](http://www.futaba-rc.com/faq/)  
Fax: 217-398-7721  
Phone: 217-398-8970 option 2

## OUTSIDE NORTH AMERICA

Please contact your Futaba importer in your region of the world to assist you with any questions, problems or service needs.

Please recognize that all information in this manual, and all support availability, is based upon the systems sold in North America only. Products purchased elsewhere may vary. Always contact your region's support center for assistance.

---

## Application, Export, and Modification

1. This product may be used for model airplane or surface (boat, car, robot) use. It is not intended for use in any application other than the control of models for hobby and recreational purposes. The product is subject to regulations of the Ministry of Radio/Telecommunications and is restricted under Japanese law to such purposes.

2. Exportation precautions:

(a) When this product is exported from the country of manufacture, its use is to be approved by the laws governing the country of destination which govern devices that emit radio frequencies. If this product is then re-exported to other countries, it may be subject to restrictions on such export. Prior approval of the appropriate government authorities may be required. If you have purchased this product from an exporter outside your country, and not the authorized Futaba distributor in your country, please contact the seller immediately to determine if such export regulations have been met.

(b) Use of this product with other than models may be restricted by Export and Trade Control Regulations, and an application for export approval must be submitted. This equipment must not be utilized to operate equipment other than radio controlled models.

3. Modification, adjustment, and replacement of parts: Futaba is not responsible for unauthorized modification, adjustment, and replacement of parts on this product. Any such changes may void the warranty.

### Compliance Information Statement (for U.S.A.)

This device, trade name Futaba Corporation of America, model number R7008SB, complies with part 15 of the FCC Rules. Operation is subject to the following two conditions:

- (1) This device may not cause harmful interference, and
- (2) This device must accept any interference received, including interference that may cause undesired operation.

The responsible party of this device compliance is:

Futaba Service Center

3002 N Apollo Drive Suite 1, Champaign, IL 61822 U.S.A.

TEL (217)398-8970 or E-mail: [support@futaba-rc.com](mailto:support@futaba-rc.com) (Support)

TEL (217)398-0007 or E-mail: [service@futaba-rc.com](mailto:service@futaba-rc.com) (Service)



The RBRC. SEAL on the nickel-cadmium battery contained in Futaba products indicates that Futaba Corporation of America is voluntarily participating in an industry-wide program to collect and recycle these batteries at the end of their useful lives, when taken out of service within the United States. The RBRC. program provides a convenient alternative to placing used nickel-cadmium batteries into the trash or municipal waste system, which is illegal in some areas.

(for USA)

You may contact your local recycling center for information on where to return the spent battery. Please call 1-800-8BATTERY for information on Ni-Cd battery recycling in your area. Futaba Corporation of America's involvement in this program is part of its commitment to protecting our environment and conserving natural resources.

\*RBRC is a trademark of the Rechargeable Battery Recycling Corporation.

---

## Federal Communications Commission Interference Statement (for U.S.A.)

This equipment has been tested and found to comply with the limits for a Class B digital device, pursuant to Part 15 of the FCC Rules. These limits are designed to provide reasonable protection against harmful interference in a residential installation.

This equipment generates, uses and can radiate radio frequency energy and, if not installed and used in accordance with the instructions, may cause harmful interference to radio communications. However, there is no guarantee that interference will not occur in a particular installation. If this equipment does cause harmful interference to radio or television reception, which can be determined by turning the equipment off and on, the user is encouraged to try to correct the interference by one or more of the following measures:

- Reorient or relocate the receiving antenna.
- Increase the separation between the equipment and receiver.
- Connect the equipment into an outlet on a circuit different from that to which the receiver is connected.
- Consult the dealer or an experienced radio/TV technician for help.

### CAUTION:

To assure continued FCC compliance:

Any changes or modifications not expressly approved by the grantee of this device could void the user's authority to operate the equipment.

### Exposure to Radio Frequency Radiation

To comply with FCC RF exposure compliance requirements, a separation distance of at least 20cm must be maintained between the antenna of this device and all persons.

This device must not be co-located or operating in conjunction with any other antenna or transmitter.

### Meaning of Special Markings

Pay special attention to safety where indicated by the following marks:

- ⚠ **DANGER** - Procedures which may lead to dangerous conditions and cause death/serious injury if not carried out properly.
- ⚠ **WARNING** - Procedures which may lead to a dangerous condition or cause death or serious injury to the user if not carried out properly, or procedures where the probability of superficial injury or physical damage is high.
- ⚠ **CAUTION** - Procedures where the possibility of serious injury to the user is small, but there is a danger of injury, or physical damage, if not carried out properly.

⊘ = Prohibited      Ⓢ = Mandatory

**Warning:** Always keep electrical components away from small children.

### FLYING SAFETY

#### ⚠ WARNING

To ensure the safety of yourself and others, please observe the following precautions:

- Ⓢ **Have regular maintenance performed.** Although your 18MZ protects the model memories with non-volatile EEPROM memory (which does not require periodic replacement) and not a battery, the transmitter still should have regular checkups for wear and tear. We recommend sending your system to the Futaba Service Center annually during your non-flying-season for a complete checkup and service.

---

## Battery

- ❗ **Charge the batteries!** (See Charging the batteries, for details.) Always recharge the transmitter and receiver batteries before each flying session. A low battery will soon die potentially, causing loss of control and a crash. When you begin your flying session, reset your T18MZ's built-in timer, and during the session pay attention to the duration of usage.
- ❗ **Stop flying long before your batteries become low on charge. Do not rely on your radio's low battery warning systems, intended only as a precaution, to tell you when to recharge. Always check your transmitter and receiver batteries prior to each flight.**

## Where to Fly

We recommend that you fly at a recognized model airplane flying field. You can find model clubs and fields by asking your nearest hobby dealer, or in the US by contacting the Academy of Model Aeronautics.

You can also contact the national Academy of Model Aeronautics (AMA), which has more than 2,500 chartered clubs across the country. Through any one of them, instructor training programs and insured newcomer training are available. Contact the AMA at the address or toll-free phone number below.

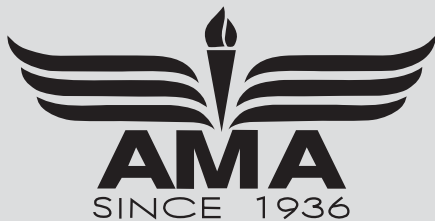

### Academy of Model Aeronautics

5161 East Memorial Drive

Muncie, IN 47302

Tele. (800) 435-9262

Fax (765) 289-4248

or via the Internet at <http://www.modelaircraft.org>

- ❗ **Always pay particular attention to the flying field's rules**, as well as the presence and location of spectators, the wind direction, and any obstacles on the field. Be very careful flying in areas near power lines, tall buildings, or communication facilities as there may be radio interference in their vicinity.

---

## Lithium polymer(Li-po) Battery Safety and Handling instructions

### IMPORTANT!

Use only the **Futaba special charger** included with this set or other chargers approved by Futaba to charge the Li-po batteries in the T18MZ transmitter included with this set.

It is important to understand the operating characteristics of Li-po batteries. Always read the specifications printed on the label of your Li-po battery and charger prior to use. Failure to follow the proceeding precautions can quickly result in severe, permanent damage to the batteries and its surroundings and possibly result in a **FIRE!**

### IMPORTANT PRECAUTIONS

- ⊗ Do not attempt to disassemble Li-po packs or cells.
- ⊗ Do not allow Li-po cells to come in contact with moisture or water at any time.
- ⚠ Always provide adequate ventilation around Li-po batteries during charge, discharge, while in use, and during storage.
- ⊗ Do not leave a Li-po battery unattended at any time while being charged or discharged.
- ⊗ Do not attempt to charge Li-po batteries with a charger that is NOT designed for Li-po batteries, as permanent damage to the battery and charger could result.
- ⚠ Always charge Li-po batteries in a fireproof location. Do not charge or discharge Li-po batteries on carpet, a cluttered workbench, near paper, plastic, vinyl, leather or wood, or inside an R/C model or full-sized automobile! Monitor the charge area with a smoke or fire alarm.
- ⊗ Do not charge Li-po batteries at currents greater than the “1C” rating of the battery (“C” equals the rated capacity of the battery).
- ⊗ Do not allow Li-po cells to overheat at any time! Cells which reach greater than 140 degrees Fahrenheit (60°C) should be placed in a fireproof location.
- ⚠ Li-po cells will not charge fully when too cold or show full charge.
- ⚠ It is normal for the batteries to become warm during charging, but if the charger or battery becomes excessively hot disconnect the battery from the charger immediately!! Always inspect a battery which has previously overheated for potential damage, and do not re-use if you suspect it has been damaged in any way.
- ⊗ Do not use a Li-po battery if you suspect physical damage has occurred to the pack. Carefully inspect the battery for even the smallest of dents, cracks, splits, punctures or damage to the wiring and connectors. DO NOT allow the battery’s internal electrolyte to get into eyes or on skin—wash affected areas immediately if they come in contact with the electrolyte. If in doubt, place the battery in a fire-proof location for at least 30 minutes.
- ⊗ Do not store batteries near an open flame or heater.
- ⊗ Do not discharge Li-po batteries at currents which exceed the discharge current rating of the battery.
- ⚠ Always store Li-po cells/packs in a secure location away from children.

### Secure Digital (SD) Memory Card Handling Instructions (SD card is not included with this set)

- ⊗ Never remove the SD card or turn off power while entering data.
- ⊗ Never store the SD card where it may be subject to strong static electricity or magnetic fields.
- ⊗ Do not expose the SD card to direct sunlight, excessive humidity or corrosive environments.
- ⊗ Do not expose the SD card to dirt, moisture, water or fluids of any kind.
- ⚠ Be certain to insert the SD card in the correct direction.



---

## At the flying field

To prevent possible damage to your radio gear, turn the power switches on and off in the proper sequence:

1. Pull throttle stick to idle position, or otherwise disarm your motor/engine.
2. Turn on the transmitter power and allow your transmitter to reach its home screen.
3. Confirm the proper model memory has been selected.
4. Turn on your receiver power.
5. Test all controls. If a servo operates abnormally, don't attempt to fly until you determine the cause of the problem.

Test to ensure that the FailSafe settings are correct after adjusting them. Turn the transmitter off and confirm the proper surface/throttle movements. Turn the transmitter back on.

6. Start your engine.
7. Complete a full range check.
8. After flying, bring your throttle stick to idle position, engage any kill switches or otherwise disarm your motor/engine.
9. Turn off receiver power.
10. Turn off transmitter power.

If you do not turn on your system in this order, you may damage your servos or control surfaces, flood your engine, or in the case of electric-powered or gasoline-powered models, the engine may unexpectedly turn on and cause a severe injury.

- ❗ **While you are getting ready to fly, if you place your transmitter on the ground, be sure that the wind won't tip it over. If it is knocked over,** the throttle stick may be accidentally moved, causing the engine to speed up. Also, damage to your transmitter may occur.
- ❗ In order to maintain complete control of your aircraft it is important that **it remains visible at all times.** Flying behind large objects such as buildings, grain bins, etc. is not suggested. Doing so may result in the reduction of the quality of the radio frequency link to the model.
- ⊘ **Do not grasp the transmitter's antenna during flight.** Doing so may degrade the quality of the radio frequency transmission.
- ❗ As with all radio frequency transmissions, the strongest area of signal transmission is from the sides of the transmitter's antenna. As such, the antenna should not be pointed directly at the model. If your flying style creates this situation, easily move the antenna to correct this situation.
- ⊘ As with all radio frequency transmissions, the strongest area of signal transmission is from the sides of the transmitter's antenna. As such, the antenna should not be pointed directly at the model. If your flying style creates this situation, easily move the antenna to correct this situation.

---

## BEFORE USE

### FEATURES

#### FASSTest system

The T18MZ transmitter adopted the newly developed bidirectional communication system "FASSTest".

Data from the receiver can be checked at the transmitter. FASSTest is a maximum 18 channels (linear 16 channels + switch 2 channels) 2.4GHz dedicated system.

#### S.BUS2 system

By using the S.BUS2 system multiple servos and gyros and sensors of the newly increased bidirectional system can be easily and cleanly wired without any mistakes.

#### WindowsCE

T18MZ utilizes the world famous Microsoft Windows CE, which offers outstanding dependability and valuable resources.

#### Color LCD

T18MZ has a HVGA (640x240 pixels) wide screen full color LCD. It has a backlight and the screen is manufactured of a transreflective construction which enables both indoor and outdoor visibility.

#### Music Play

T18MZ can playback WMA (Windows Media Audio) files on a SD-Card. You can enjoy music by the internal speaker or stereo headphone from the earphone jack, and you can assign switches to start/stop your music. You can download the WMA files of your own music from your PC.

#### Voice Recording

You can record your own voice by internal microphone and then play back commands to be assigned to certain switches. Recording time is 3 seconds maximum and 24 voice files can be stored.

#### Camera function + picture paste function

The transmitter has a 0.03M megapixels digital camera function. Picture files and other files can be pasted as pictures of each model. Identification during model selection and similar situations is easy and convenient. (File type: bmp, picture size: 158x80 pixels)

#### Compact Flash

The model data, the music file, and the voice file and the picture file are preserved as (SD) card of the Compact flash marketing.

#### High capacity lithium polymer battery (3500mAH)

The T18MZ transmitter can be used for a long time by installing a high capacity lithium polymer battery.

#### USB connection

An USB connector is built in. A commercial PC mouse and keyboard can be used. The model data can also be stored in a USB memory.

---

### **Editing**

The touch panel and rotary encoder editing system will allow you to edit your model in the manner that is easiest and most functional for you.

### **Functions**

The internal dual processors operate the many 18MZ FEATURE functions and optimize the response time. Most of the mixing functions are operated by curves which give you more precise settings.

### **Stick**

Each axis is supported by dual ball bearings. This allows for finer and more precise operation, the new potentiometers also offer longer life.

### **Replaceable switches**

You can replace 8 of the toggle switches on the right and left shoulder, with optional switches (two position, three position, and momentary etc.).

### **R7008SB**

The system comes with a T18MZ dedicated FASSTest system, S.BUS2, and R7008SB 18- channel diversity receiver.

### **Vibration function**

Low battery and other alarms are generated by a vibration motor. The alarms to be generated can be selected.

---

## Contents and Technical Specifications

(Specifications and ratings are subject to change without notice.)

**Your 18MZAP/HP (packaged with a S.BUS receiver) includes the following components:**

- T18MZ Transmitter
- R7008SB Receiver
- LT2F3500XH Li-polymer battery & AC adaptor
- Switch harness/DSC cord
- Tool Box (includes special jig for adjustment)
- Neck strap

The set contents depend on the type of set.

### **Transmitter T18MZAP/HP**

Operating system: 2-stick, 18 channels, 2.4GHz  
FASSTest /FASST/S-FHSS system

Transmitting frequency: 2.4 GHz

Power supply: 7.4V LT2F3500 Li-polymer battery

Current drain: 1 ampere maximum (RF power on and  
back light on) 700mA average

### **Receiver R7008SB**

**(FASSTest, S.BUS2, Diversity)**

Receiving frequency: 2.4 GHz FASSTest system

Power requirement: 6.6 V Li-Fe battery

Current drain: 75 mA

Size: 24.9x47.3x14.3 mm

Weight: 10.9 g.

---

**The following additional accessories are available from your dealer. Refer to a Futaba catalog for more information:**

- LT2F3500XH Transmitter battery pack - the (3500mAh) transmitter Li-polymer battery pack may be easily exchanged with a fresh one to provide enough capacity for extended flying sessions.
- Trainer cord - the optional training cord may be used to help a beginning pilot learn to fly easily by placing the instructor on a separate transmitter. Note that the T18MZ transmitter may be connected to another T18MZ system, as well as to any other models of Futaba transmitters. The T18MZ transmitter uses the newer “Micro” rectangular type cord plug. Both Micro- to-Micro and Micro-to-round plug style trainer cords are available.
- Neckstrap - a neckstrap may be connected to your T18MZ system to make it easier to handle and improve your flying precision since your hands won't need to support the transmitter's weight.
- Y-harnesses, servo extensions, etc - Genuine Futaba extensions and Y-harnesses, including a heavy-duty version with heavier wire, are available to aid in your larger model and other installations.
- Gyros - a variety of genuine Futaba gyros are available for your aircraft or helicopter needs.
- Governor (GV1.GY701.CGY750) - for helicopter use. Automatically adjusts throttle servo position to maintain a constant head speed regardless of blade pitch, load, weather, etc.
- Receivers - various models of Futaba receivers may be purchased for use in other models. (Receivers for 2.4GHz types are available.)

## Transmitter controls

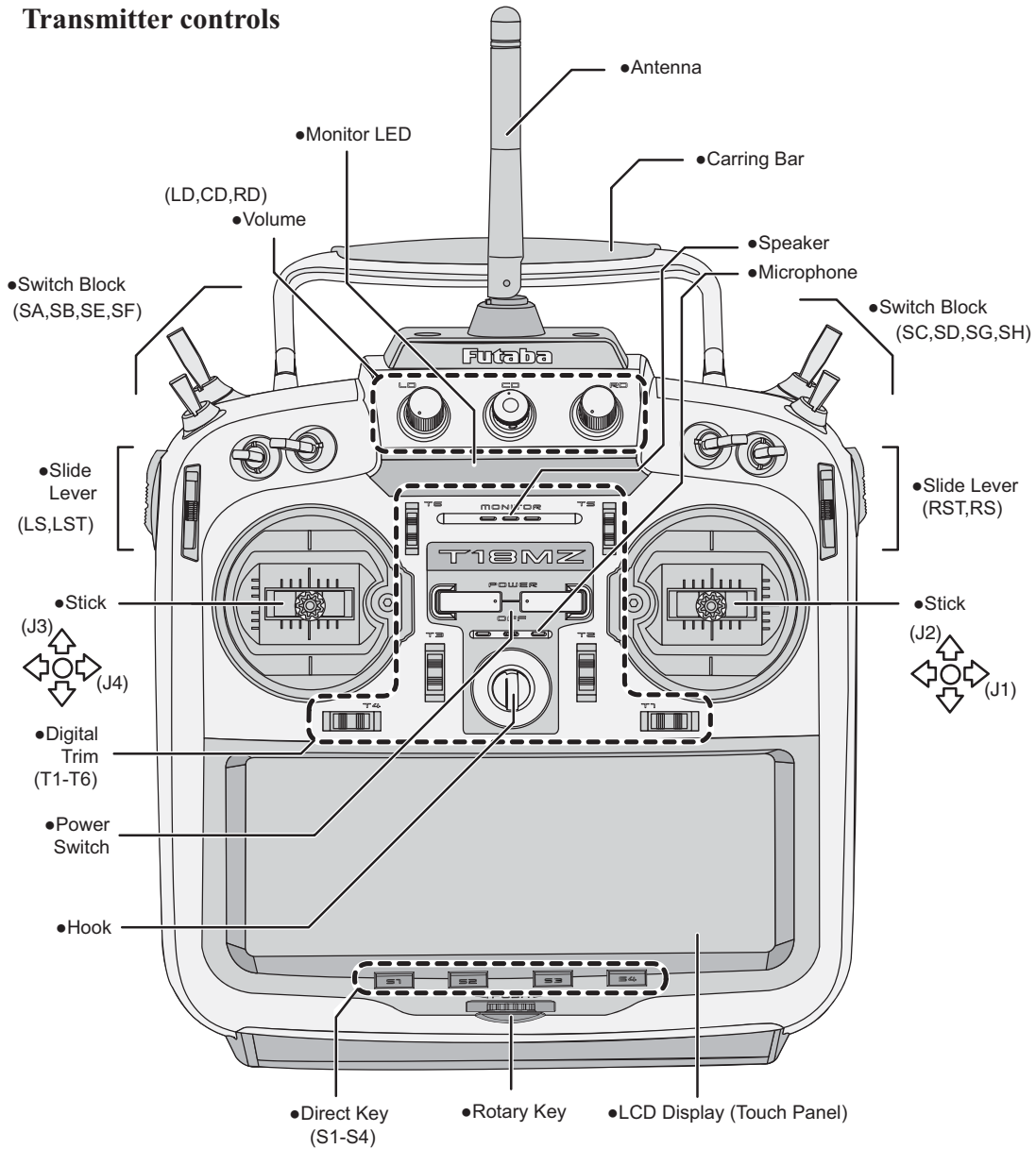

### Cautions on handling antenna

#### ⚠ WARNING

- ⊘ Do not touch the antenna during operation.  
\*There is the danger of erroneous operation causing a crash.
- ⊘ Do not carry the transmitter by the antenna.  
\*There is the danger that the antenna wire will break and operation will become impossible.
- ⊘ Do not pull the antenna forcefully.  
\*There is the danger that the antenna wire will break and operation will become impossible.

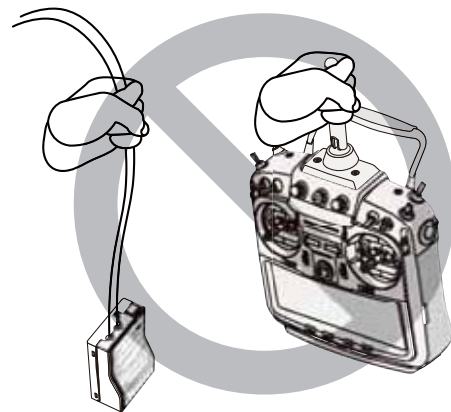

### •Steerable antenna

The antenna rotating angle is  $90^\circ$  and its steerable angle is also  $90^\circ$ . Do not try to bend the antenna farther than this. The antenna may break. Also, the antenna cannot be detached and reattached.

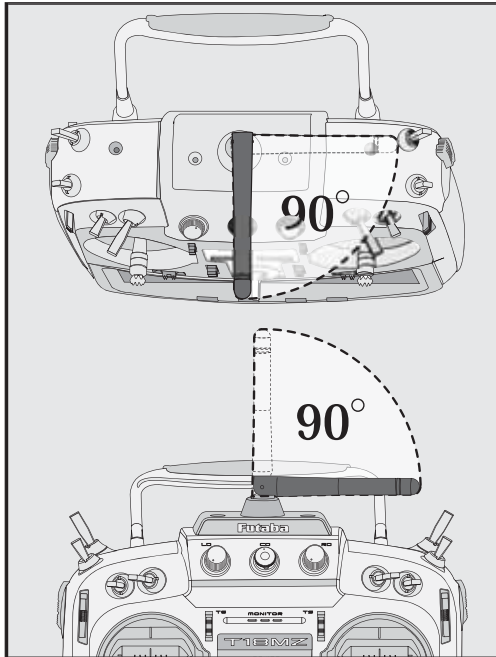

### •Angle adjustment of the antenna

The antenna rotation and angle can be adjusted. The antenna features weak radio waves in the forward direction and strong radio waves in the sideways directions. Adjust the antenna angle to match your flying style.

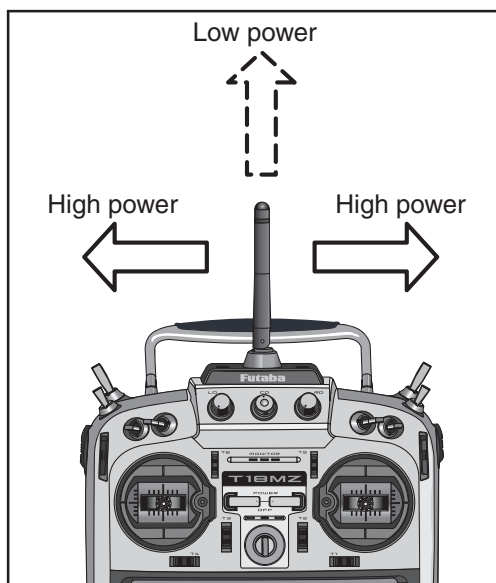

### LED monitor

The status of the transmitter is displayed by changing the "MONITOR" section LED.

(LED Display)

- FASSTest mode → Blue light
- FASST mode → Green light
- FHSS mode → Yellow light
- RF-OFF → Violet light
- Starting → Red light

### Switch reallocation

You can reallocate the toggle switches on the shoulders of the transmitter, as you like.

(Default settings)

- SA : 3 positions; Alternate; Short lever
- SB : 3 positions; Alternate; Long lever
- SC : 3 positions; Alternate; Long lever
- SD : 3 positions; Alternate; Short lever
- SE : 3 positions; Alternate; Short lever
- SF : 2 positions; Alternate; Long lever
- SG : 2 positions; Alternate; Short lever
- SH : 2 positions; Momentary; Long lever

\*You can choose switch and set the ON-direction in the setting screen of the mixing functions.

### •When you change switches:

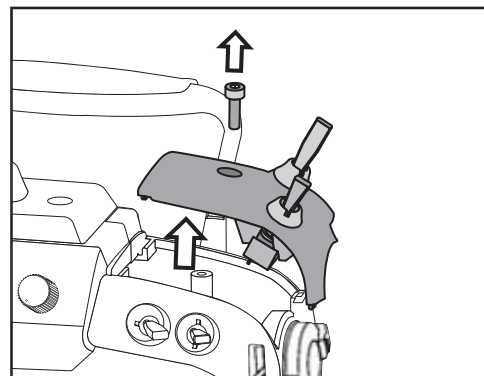

To relocate switches;

1. Make sure your transmitter is off, and use the attached 2.5mm hexagonal wrench (inside stylus) to turn the screw counter-clockwise on the switch block and detach the block.
2. Disconnect the connectors of switches you want to change.
3. Use the attached jig (inside stylus) to turn the face nuts counterclockwise, this will detach the switches.

4. To re-attach, use the face nuts to attach switches from other positions or optional switches to the switch block.
5. Connect your connectors.
6. Insert the switch block so that it fits correctly into the body of the transmitter (as shown in the picture) and use the hexagonal wrench to tighten the screws.

### Volume

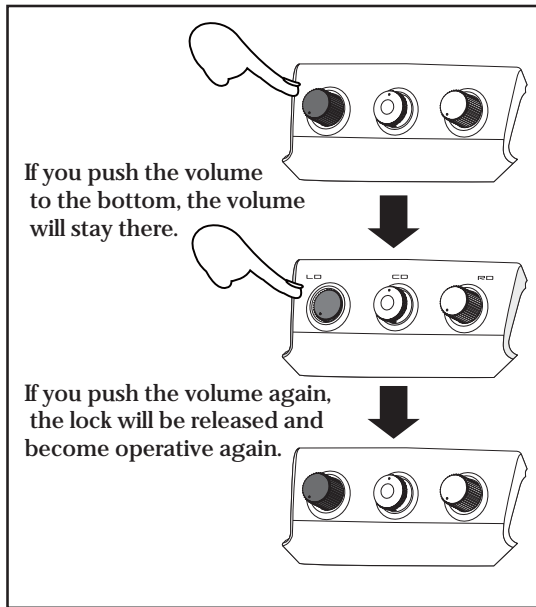

### Volume LD, CD, and RD:

If you push the volume to the bottom, the volume will stay there. If you push the volume again, the lock will be released and become operative again.

This volume is digital type (rotary encoder). This volume works as both a volume and a push-switch.

- \*T18MZ beeps when the volume knob reaches center.
- \*You can check the volume position on the Dial Monitor screen in the Linkage menu.
- \*You can use each setting screen of the mixing functions to select volumes and define the direction of its movement.

### Slide Lever

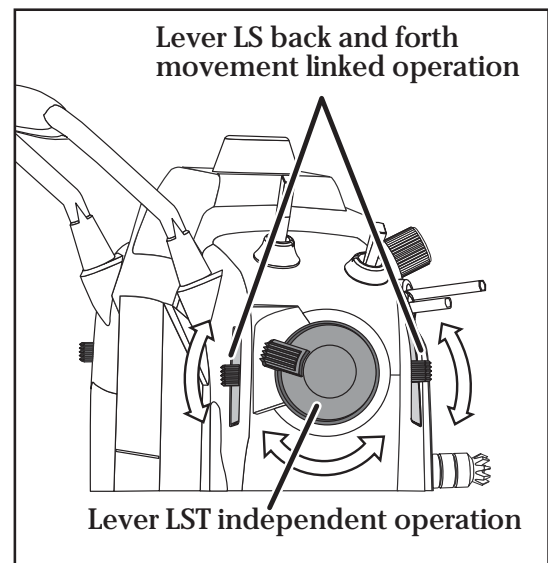

### LST (Left), RST (right):

Outside levers

### LS (Left), RS (right):

Inside levers: Each lever has two ends, one in front and the other on the back.

- \*It sounds when the lever comes to the center.
- \*You can check the lever position on the dial-monitor screen in the linkage menu.
- \*You can select a slide lever and set the movement direction on the setting screen of mixing functions.



## Digital trim

This transmitter is equipped with digital trims. Each time you press a trim button, the trim position moves one step. If you continue pressing it, the trim position starts to move faster. In addition, when the trim position returns to the center, the tone will change. You can always monitor trim positions by graphics on the screen. To change the trim rate, you must activate this through the function menu, within the linkage menu. Touch the trim button and you will access another screen which enables you to change the trim percentages.

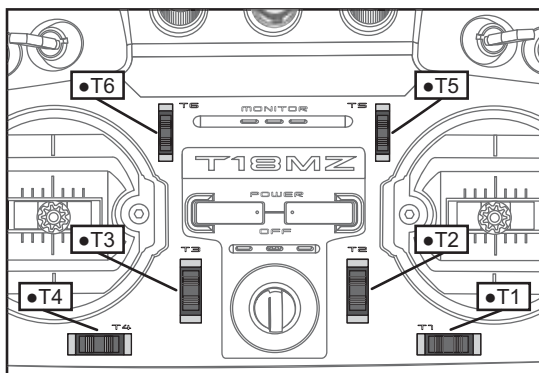

Note: The trim positions you have set will be stored in the non-volatile memory and will remain there.

## Touch Panel/ Rotary Key/ Direct Key

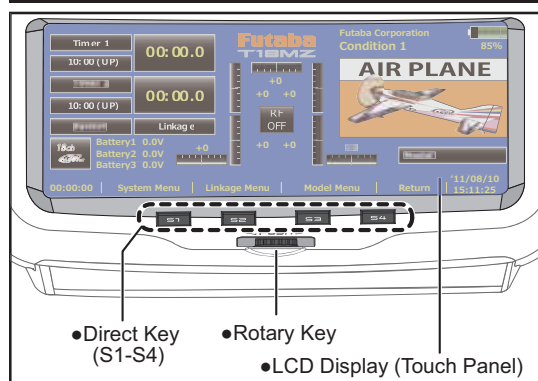

Touch panel, rotary keys and direct keys are used for entering data.

### Touch Panel

Touch the panel with your finger or the attached stylus pen, which is also used as a toolbox, to enter data.

## ⚠ Caution

! Touch softly the Touch Panel with the stylus pen or your fingertips.

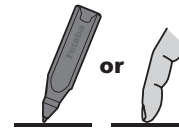

\*Plastic film is attached on the glass of the touch panel. Please be careful so that you don't scratch the touch panel with something hard, such as metal and sand sticking on the surface. And don't push the touch panel too hard and don't give any physical shock to the surface.

\*Although you may find some air bubbles under the plastic panel due to environmental changes such as temperature, it is not a defect.

### Rotary key

In addition to touch panel, you can select items by rotating the rotary keys to the left or to the right.

\*There is also a function which cannot be operated only by Rotary key.

### Direct key

You can directly call your favorite functions or menu screens.

(The default setting at the factory)

- S1: System menu
- S2: Linkage menu
- S3: Model menu
- S4: Return

[How to change assignment of the direct key]

1. Open the screen you want to call. Then push S1 and S4 keys simultaneously. (You will see the direct key setting screen.)
2. Select the direct key.
3. The [Enter] key is pressed.
4. The [Yes] key is pressed.

## ⚠ Danger

! Since the sensitivity of T18MZ of the touch panel improved, if a hook band etc. touch, it is dangerous. Even if you touch a panel during a flight, please use the touch panel lock in which a screen is locked.

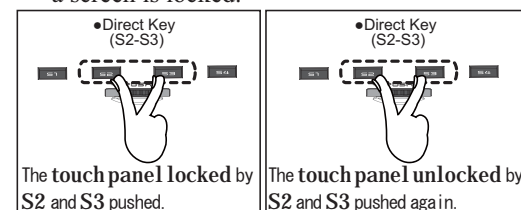

The function which acts as Locke of the touch panel

## Stick Adjustment

### Adjustment of the stick lever angle

You can make fine adjustments to the angle of a stick lever either inwards or outwards from the center stick position.

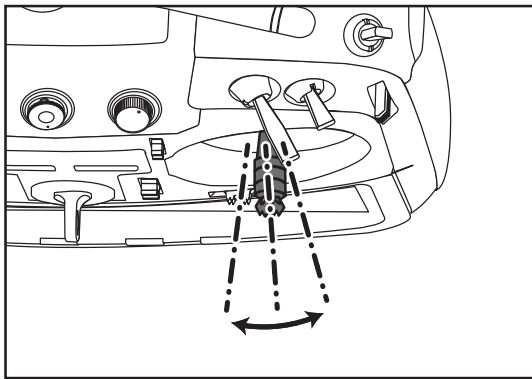
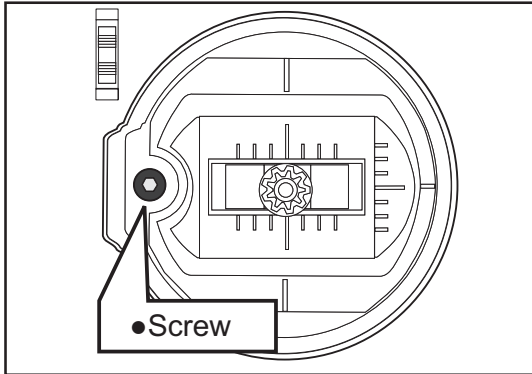

Use the attached 1.5mm hexagonal wrench (inside stylus) to turn the screw clockwise to adjust the stick outwards, or counter-clockwise to tilt it inward.

Note: The screw will fall out if you turn the screw counter-clockwise too far.

### Adjustment of the lever length

You can adjust the length of stick levers, as you like. It is recommended to adjust the length of the sticks in line with your hand size.

### [How to adjust the length]

1. Hold the lever head "B" and turn the lever head "A" counter-clockwise, the lock will be released.
2. Adjust the stick lever to the desired length by turning lever head A.

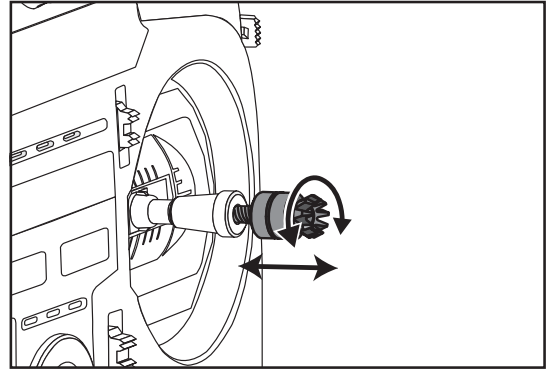

3. Securely lock the stick lever by holding lever head A and turning lever head B counterclockwise.

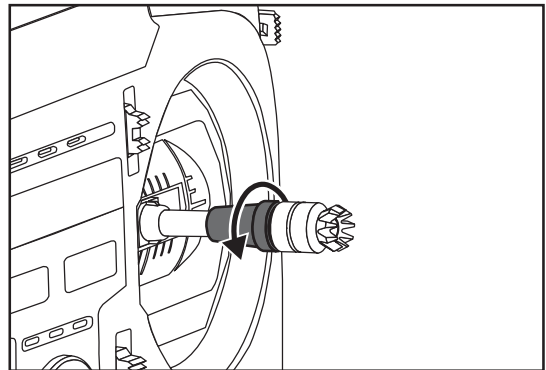

### Adjustment of Stick Lever Tension

You can adjust the tension of stick-levers.

The rubber cover in the back is removed first.

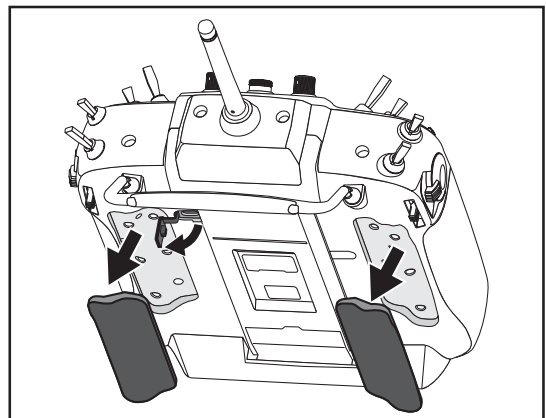

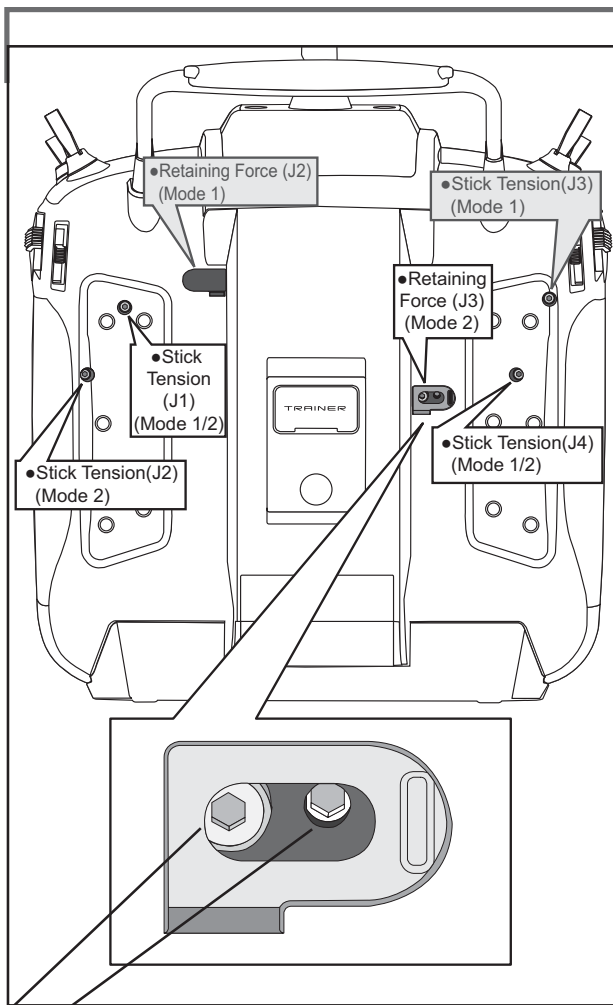

[Adjustment of tension]

### Adjustment of Throttle Stick (Ratchet System)

You can also choose either airplane ratchet system or helicopter-touch.

1. Open the dust protection cap on the back of the transmitter that is covering the hole for throttle stick adjustment.
2. Use the attached 1.5mm hexagonal wrench (inside stylus) to turn the adjustment screw and set it as you prefer. Turning the screw clockwise increases the tension.

For airplanes: Adjust the screw on the left.

For helicopters: Adjust the screw on the right.

In changing the setting from airplane to helicopter (or heli to airplane);

1. Turn the screw counter-clockwise until the throttle stick moves freely, and turn the screw clockwise to adjust it to the tension you prefer.

\*This transmitter has two ratchet plates, one for airplane and the other one for helicopter. If you tighten both screws, you won't be able to achieve the adjustment that you need because of the overlap of those two adjustments.

\*If you want to change the setting from airplane to helicopter (or from helicopter to airplane), turn counterclockwise until the throttle stick moves freely. Then turn the screw for the helicopter until you get the tension force you like.

### Battery exchange

**Note: If you detach the battery while the power is on, the data you have set will not be saved.**

[How to remove battery LT2F3500XH]

1. Using the tabs at the side of the transmitter, open the side door to the rear as shown in the figure.

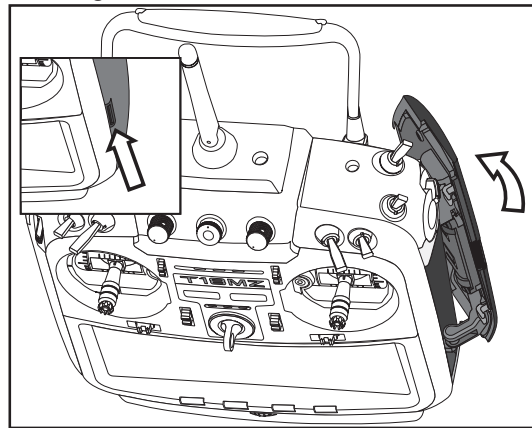

2. Open the battery cover inside the transmitter by sliding it upward as shown in the figure.

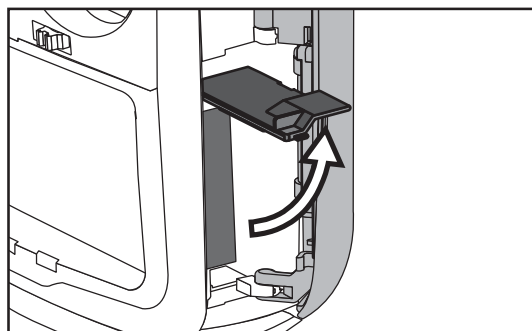
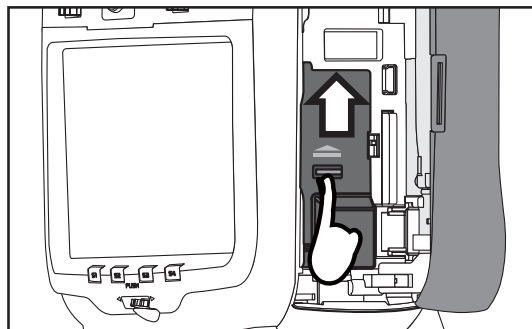

3. Using the transmitter body connector slider, pull out the battery connector.

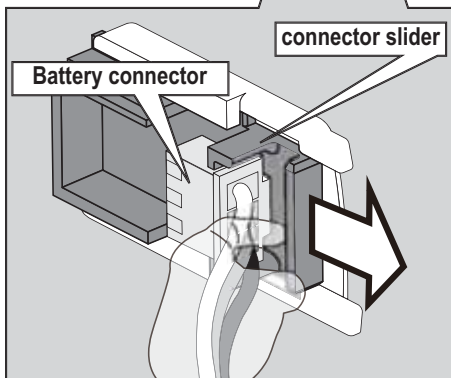
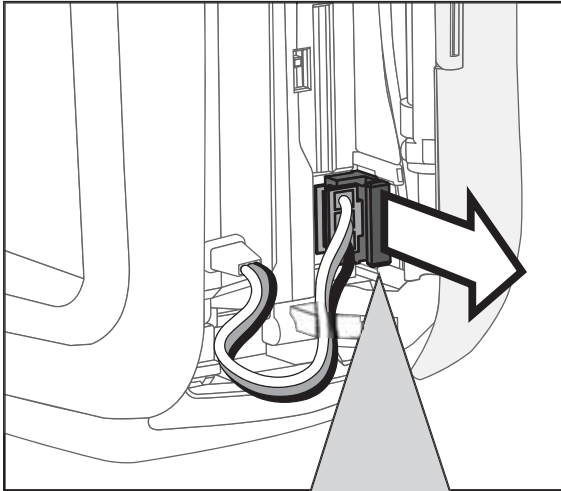

\*Remove the connector by pulling the slider and not the wiring.

4. Pull out the battery.

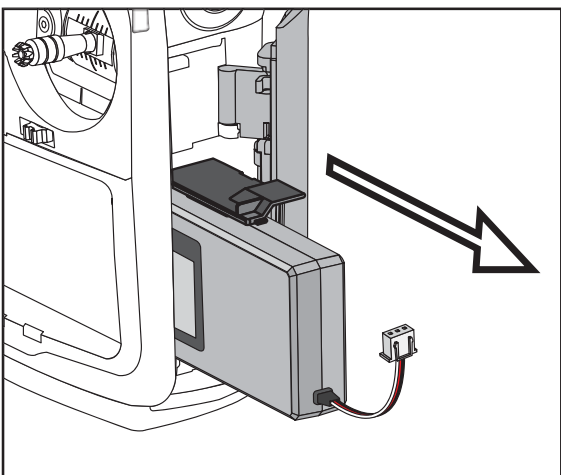

[How to install battery LT2F3500XH]

1. Insert the battery into the transmitter.

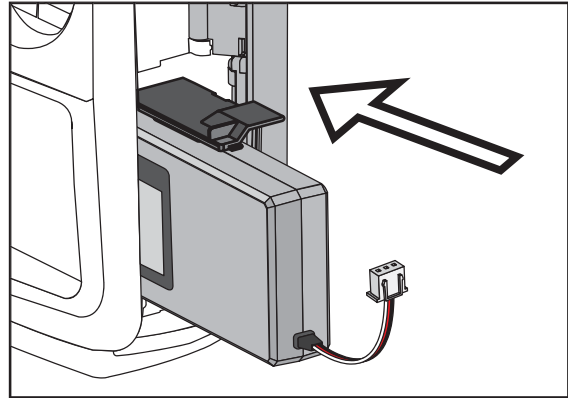

2. Insert the battery with the battery connector facing the direction shown in the figure. (Push the housing section and not the wiring.)

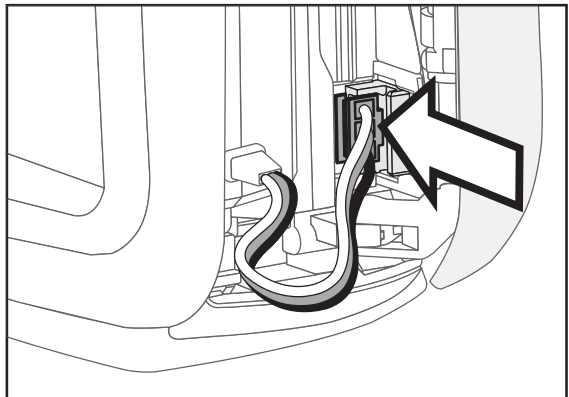

3. Arrange the battery wiring as shown in the figure.

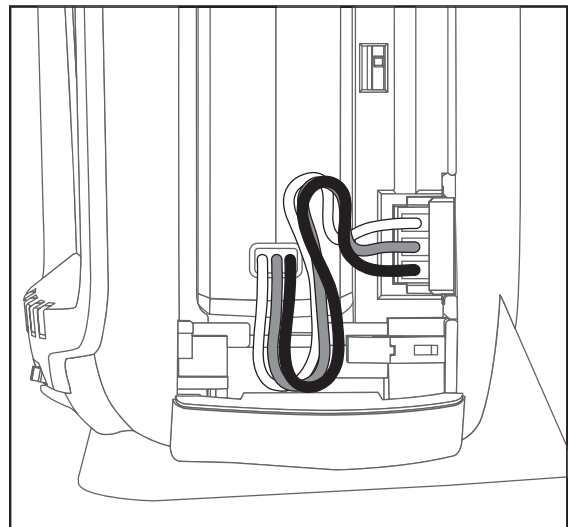

4. Close the battery cover so that the wiring is not pinched and lock the cover by pushing downward.

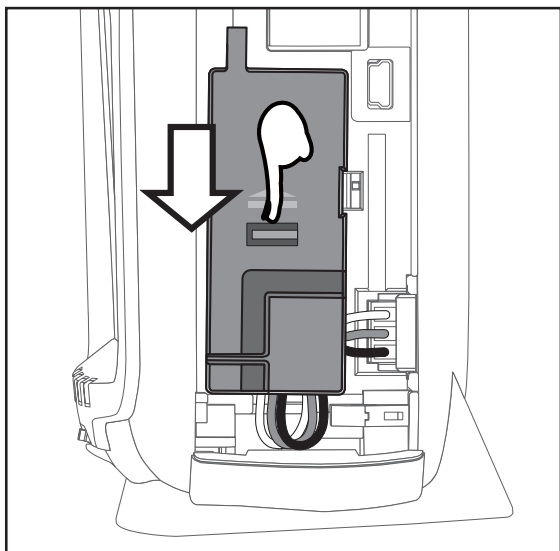

5. Close the side door.

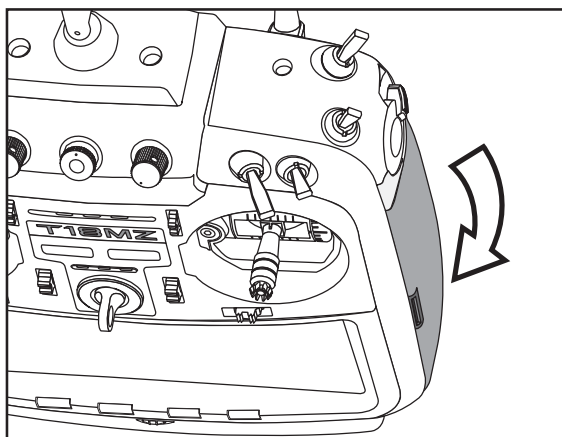

**⚠ Warning**

- ❗ Be careful to not drop the battery.

- ⊘ Never take out the battery from the T18MZ transmitter while the LED monitor is blinking after turning off the power the T18MZ transmitter.

\* Internal devices such as memories may have been destroyed.

\* If there is any problem, the message "Backup Error" will be shown the next time when you turn on the power of the transmitter. Do not use the transmitter as it is, send it back for a check to the Futaba Service Center.

**Back lid**

The charging connector, earphone jack, and S.BUS setting connector, charge LED are accessed by opening the transmitter rear cover as shown in the figure.

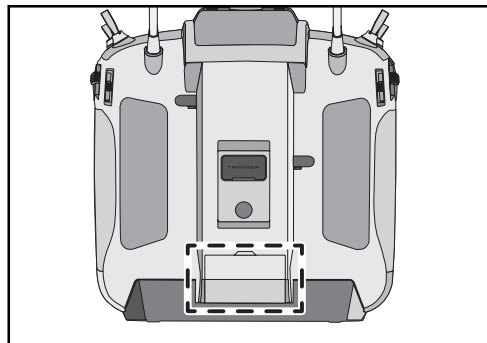

[How to open back lid.]

1. Open the transmitter rear cover as shown in the figure.

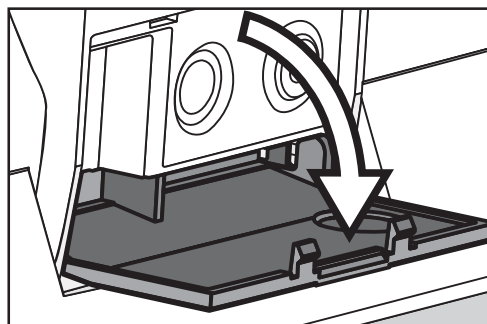
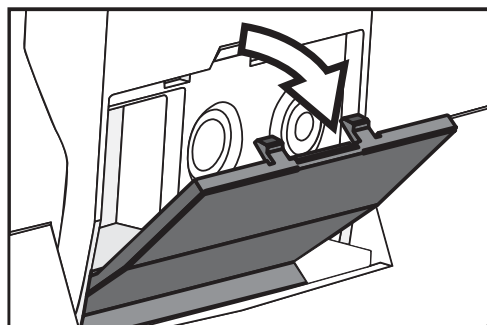

2. House the rear cover by pushing it into the transmitter.

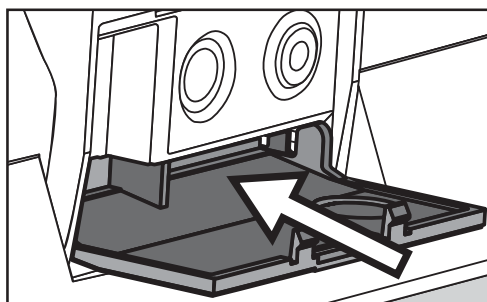

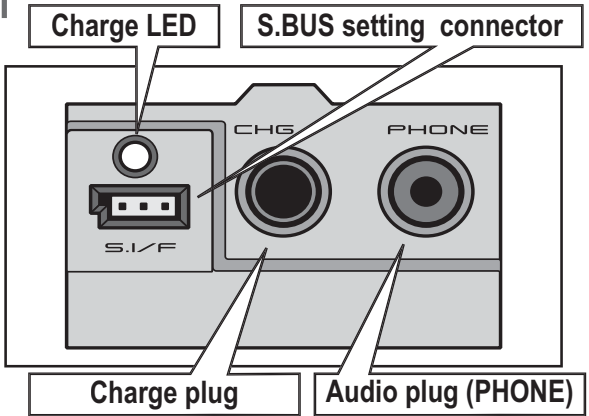

3. When not using the connector, pull out and close the rear cover.

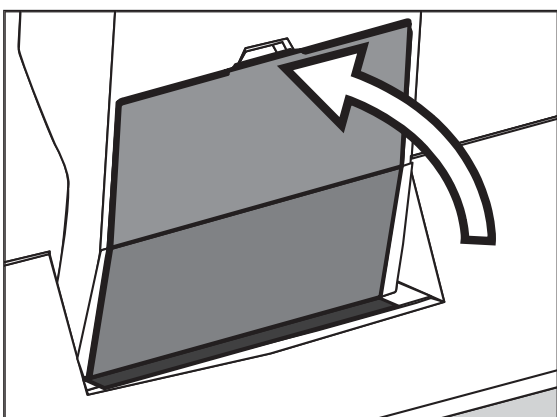
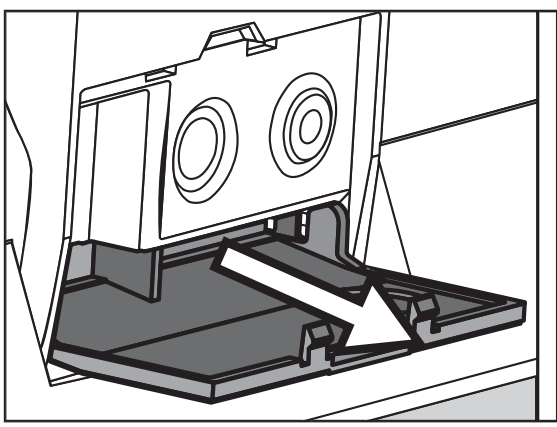

**Connector/Plug**

1. The back of transmitter.

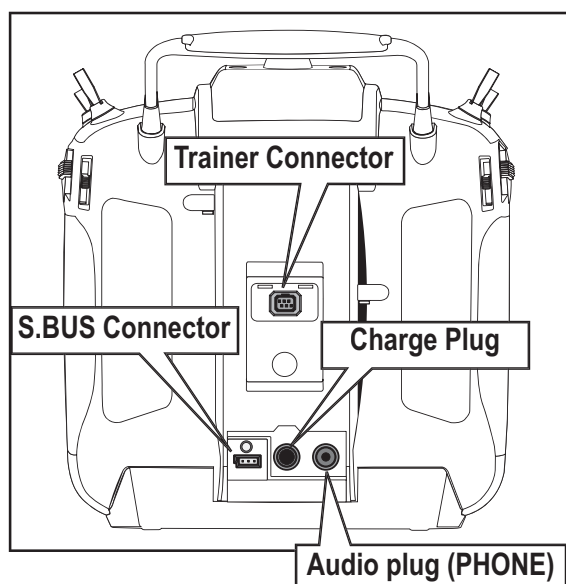

2. Inside of transmitter of side cover

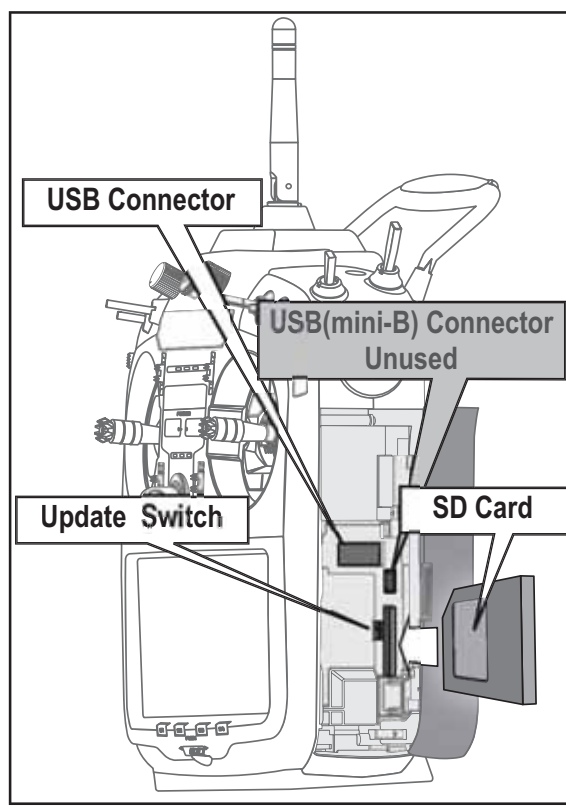





### SD Card (sold separately)

SD card can store various files, such as model data, music, sound and pictures. SD card on the market can be used for T18MZ. The card is locked when it is pushed in all the way. When removing the card, release the lock by pushing in the card again.

### Warning

-  Be sure to turn off the power to the transmitter before inserting or removing the SD card.
-  As the SD card is a precision device, do not use excessive force when inserting.
-  If model data generated by a new software version transmitter is copied to an old software version transmitter, the transmitter may operate erroneously. Copy the model data after updating the copy destination transmitter to the new software version.

### Read data from a PC

Saving music and image files edited by a PC into the SD card, you can use those files on your T18MZ transmitter. Equipment for reading and writing SD cards are available at most electronics stores.

### Stored data

The life of the SD card is limited due to the use of Flash memory. When you have a problem of saving or reading data such as picture data after a long period of use, please get a new SD card.

\*We do not have the responsibility of compensating any failure or damage to the data stored in the memory card no matter what the reason is. Be sure to keep the backup of your important data in your SD card.

\***No necessity for backup;** T18MZ transmitters and SD cards are using nonvolatile memory devices so that the data stored in those will not be destroyed even without a backup battery. The clock for the transmitter depends on the Lithium battery.

### Update Switch

When using an SD card to update the T18MZ software, set this switch to the up position. Then input the software to be updated to the SD card from the Futaba importers homepage and update the software in accordance with the updating procedure.

### USB port

The following functions can be used with USB connector.

- USB Mouse

When a mouse is connected, a cursor will appear on the screen and the mouse can be used instead of the touch panel.

- USB Keyboard

When a keyboard is connected, the model name and other data can be input by keyboard.

- USB Memory

The model data, etc. can be saved to a commercial USB memory.

### Connector for trainer function (TRAINER)

When you use trainer function, connect the optional trainer cable between the transmitters for teacher and student.

\*You can set the trainer function on the Trainer Function screen in the system menu

### Connector for DSC function (DSC)

You can operate the transmitter without transmitting radio waves by connecting the transmitter and the receiver to the DSC cable.

\*Please refer to the section "Connection between Receiver/Servo"

### S.BUS connector (S.I/F)

When setting an S.BUS servo and telemetry sensor connect the servo and telemetry sensor here. (Supply power by 3-way hub or 2-way cord.)

### Audio plug (PHONE)

Connecting a stereo headphone to this plug, you can enjoy music files stored in the SD card.

### Connector for battery charger (CHG)

This is the connector for charging the battery LT2F3500XH that is installed in the transmitter. It is not possible to use it excluding the AC adaptor only for the transmitter.

### Danger

-  Do not connect any other chargers. The charger for the receiver battery cannot be used for the transmitter.

### USB port (mini-B)

\*This is for factory use only.

### Camera function

This transmitter has a digital camera function. A picture of your favorite model and other pictures (300,000 pixels) can be allocated to transmitter model data.

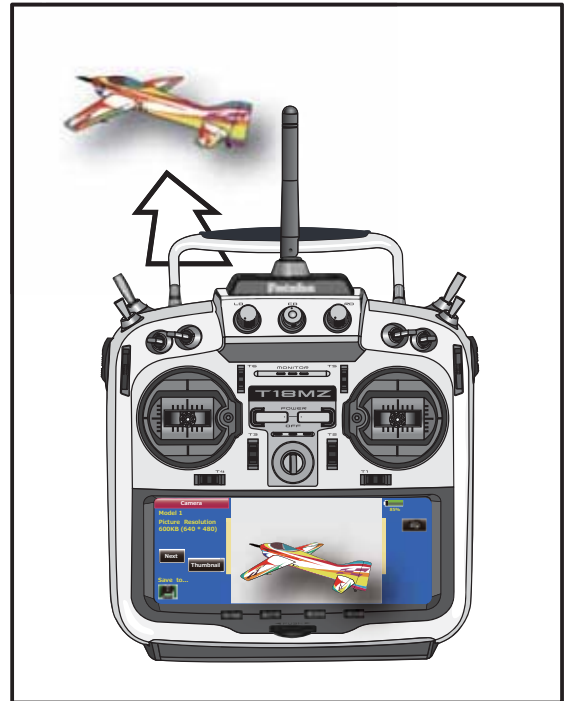
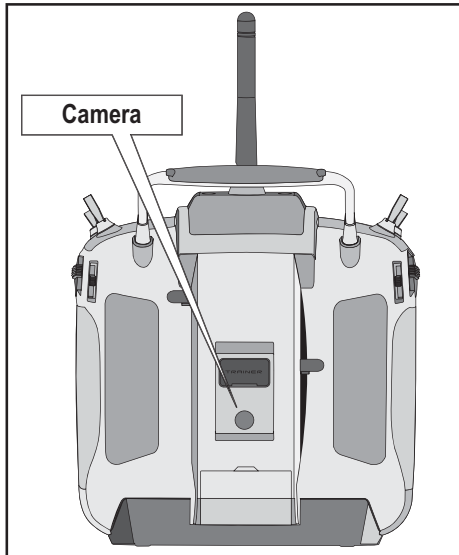

### Warning

 Do not use the camera function during flight and when starting the engine.

\*There is the danger that the model may be lost from view and crash.



## Receiver nomenclature

Before using the receiver, be sure to read the precautions listed in the following pages.

### Receiver R7008SB

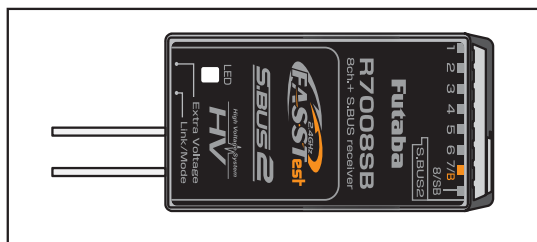

#### Connector

"1 through 6": outputs for the channels 1 through 6

"7/B": outputs of 7 channels and power.

"8/SB": outputs of 8 channels or S.BUS port.

[S.BUS Sevo S.BUS Gyro] → ↑

"S.BUS2": outputs of S.BUS2 port.

[Telemetry Sensor etc.] → ↑

\*When using 9 or more channels, use an S.BUS function. Or one more set R7008SB is purchased and two sets of receivers are used by one set of a transmitter.

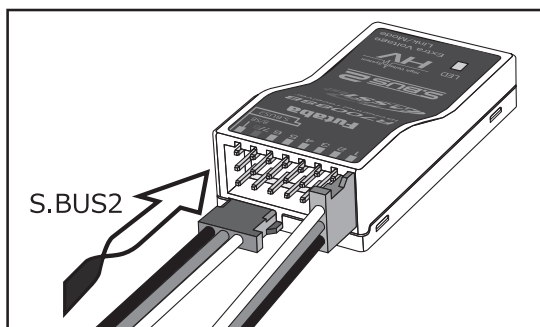

#### Connector insertion

Firmly insert the connector in the direction shown in the figure. Insert the S.BUS2 by turning it 90 degrees.

### ⚠ Warning

#### S.BUS2 connectors

❗ Don't connect an S.BUS servo / gyro to BUS2 connector.

#### LED Monitor

This monitor is used to check the CH mode of the receiver.

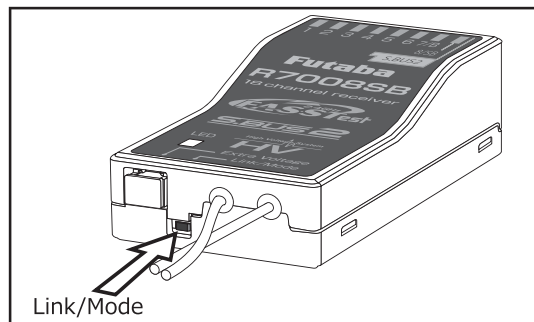

#### Link/Mode Switch

It pushes with a plastic driver.

It is used for CH mode change.

(It is not used by a link.)

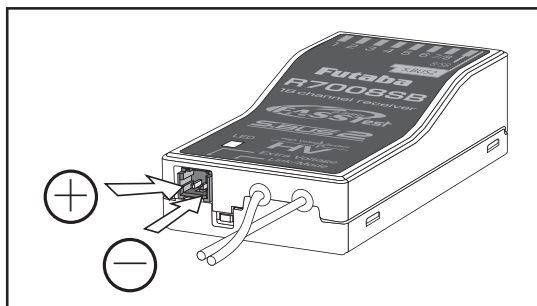

#### Extra Voltage Connector

When using this connector, Use this connector when sending the voltage (DC0 ~ 70V) of the drive battery of a motor craft, etc. from the receiver to the transmitter.

Please branch wiring of a drive battery, attach an attached connector, and connect with Extra Voltage connector.

### ⚠ Danger

⊘ Don't touch wiring.

\* There is a danger of receiving an electric shock.

⊘ Do not short-circuit the battery terminals.

\* A short circuit across the battery terminals may cause abnormal heating, fire and burns.

⊘ + and - of wiring cannot be mistaken.

\* If + and - of wiring are mistaken, it will damage, ignite and explode.

⊘ Don't connection to Extra Voltage before turning on a receiver power supply.

### R7008SB CH Mode

R7008SB can change 8CH and S.BUS. Moreover, 1-8CH output can be changed to 9-16CH output. If it is moreover used only to 8CH, without your using S.BUS, the mode A of initial setting may be sufficient.

However, it is necessary for it to be necessary to change the mode by the following method, if you are required for 9 or more CH, and to use S.BUS, or to use two sets of R7008SB for one model.

[How to R7008SB CH mode change]

1. Pushing a Link/Mode switch is continued first. And a receiver is turned on as it is.→LED blinks simultaneously in green with red.→Link/Mode switch is released.
2. Whenever it pushes a Link/Mode switch, 4 Mode following Mohd changes in order. (The mode is told by the blink of LED.)
3. If it becomes the mode of hope, a Link/Mode switch will be pushed 2 seconds or more.
4. If the change in the mode finishes, the power supply of a receiver is turned off and turned on.

### R7008SB CH MODE TABLE

Receiver connector	Setting channel			
	Mode A 1 ~ 8CH	Mode B 1 ~ 7CH	Mode C 9 ~ 16CH	Mode D 9 ~ 15CH
1	1	1	9	9
2	2	2	10	10
3	3	3	11	11
4	4	4	12	12
5	5	5	13	13
6	6	6	14	14
7/B	7	7	15	15
8/SB	8	S.BUS	16	S.BUS
Red LED blink	1time	2time	3time	4time

## Servo(Optional) · Toolbox

### Servo(Optional)

Please purchase according to the purpose of using you.

\*In the case of FASSTest12CH mode, an analog servo cannot be used.

Please choose digital servo (a brushless servo is included) and an S.BUS servo.

### Servo accessories

The servo accessories are:

-Spare servo horn

-Servo mounting parts

\*Always use the servo horn mounting screws installed to the servo at the factory.

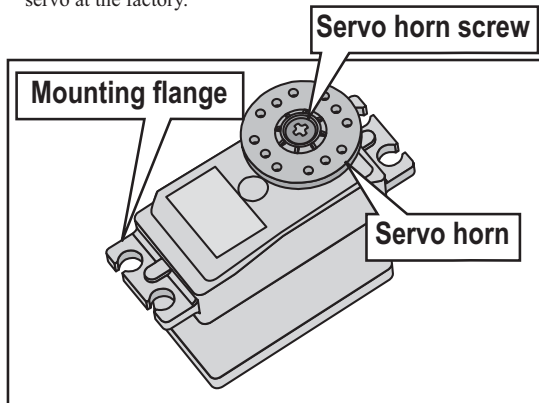

### Toolbox

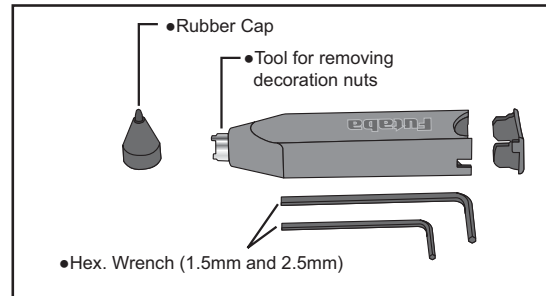

You can use the toolbox contained in the set for various adjustment of the transmitter.

### Hexagonal wrench (1.5mm and 2.5mm)

These wrenches are for adjustment of sticks, replacement of the switches and adjustment of the antenna.

### Tool for removing decoration nuts

This is for replacement of switches.

### Stylus pen

Rubber cap is attached on the tip of the toolbox. You may use this tool as a stylus pen for operating touch panel. This stylus pen can let you do more precise operation than fingers without damaging the surface.

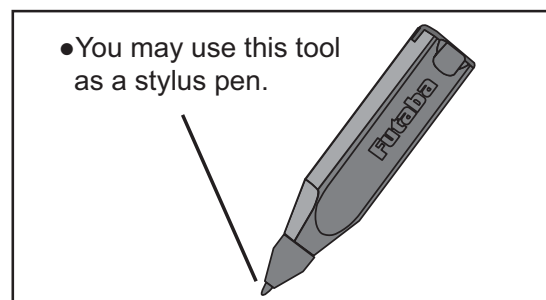

## Receiver's Antenna Installation

You will note that the R7008SB differs in appearance from the standard Futaba receiver. This receiver incorporates two separate antennas into their design which enables them to receive the radio frequency transmission at two different locations.

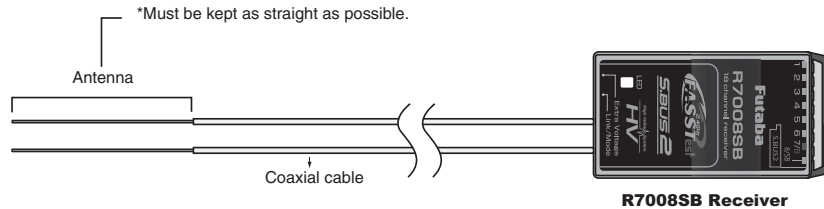

Futaba's dual antenna diversity then seamlessly selects the best signal reception between these antennas to ensure that there is no loss of signal.

To obtain the best results of the diversity function, please refer to the following instructions:

1. The two antennas must be kept as straight as possible. Otherwise it will reduce the effective range.
2. The two antennas should be placed at 90 degrees to each other.

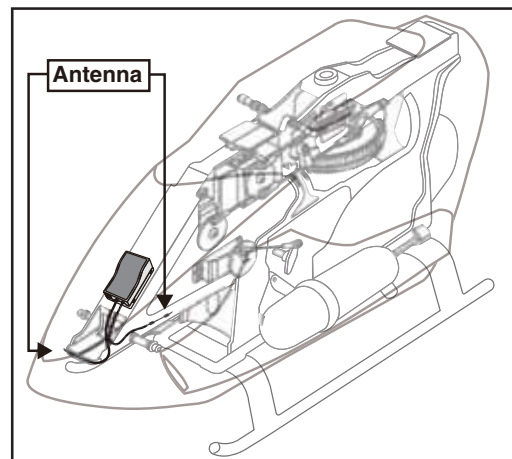
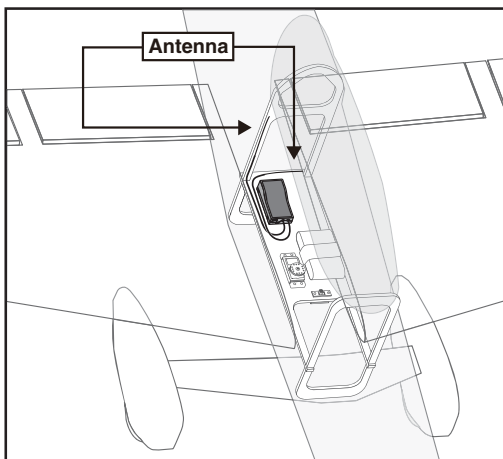
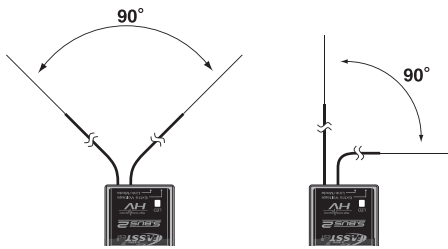

This is not a critical figure, but the most important thing is to keep the antennas away from each other as much as possible.

Larger models can have large metal objects that can attenuate the RF signal. In this case the antennas should be placed at both sides of the model. Then the best RF signal condition is obtained at any flying attitude.

3. The antennas must be kept away from conductive materials, such as metal, carbon and fuel tank by at least a half inch. The coaxial part of the antennas does not need to follow these guidelines, but do not bend it in a tight radius.
4. Keep the antennas away from the motor, ESC, and other noise sources as much as possible.

\*The two antennas should be placed at 90 degrees to each other.

\*The main purpose of the Illustration demonstrates how the antenna should be placed.

\*Receiver Vibration and Waterproofing: The receiver contains precision electronic parts. Be sure to avoid vibration, shock, and temperature extremes. For protection, wrap the receiver in foam rubber or other vibration-absorbing materials. It is also a good idea to waterproof the receiver by placing it in a plastic bag and securing the open end of the bag with a rubber band before wrapping it with foam rubber. If you accidentally get moisture or fuel inside the receiver, you may experience intermittent operation or a crash. If in doubt, return the receiver to our service center for service.

## Mounting the Servo

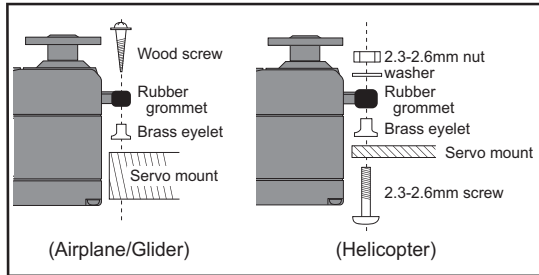

### Servo lead wires

To prevent the servo lead wires from being broken by vibration during flight, provide a margin so that the wire sticks out slightly and fasten it at suitable points. In addition, periodically check the wire during daily maintenance

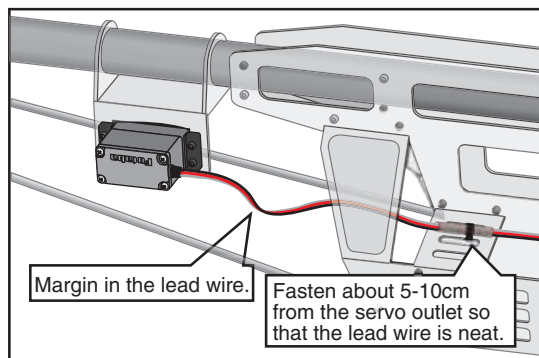

### Mounting the power switch

When mounting a power switch to an airframe, make a rectangular hole that is a little larger than the total stroke of the switch so that you can turn the switch ON/OFF without binding.

Avoid mounting the switch where it can be covered by engine oil and dust. In general, it is recommended to mount the power switch on the side of the fuselage that is opposite the muffler.

## Safety precautions when you install receiver and servos

### ⚠ Warning

#### Connecting connectors

- ⚠ Be sure to insert the connector until it stops at the deepest point.

#### How to protect the receiver from vibration and water

- ⚠ Wrap the receiver with something soft such as foam rubber to avoid vibration. If there is a chance of getting wet, put the receiver in a waterproof bag or balloon to avoid water.

#### Receiver's antenna

- ⊘ Never cut the receiver's antenna. Do not bind the receiver's antenna with the cables for servos.

- ⚠ Locate the receiver's antenna as far as possible from metals or carbon fiber components such as frames, cables, etc.

\*Cutting or binding the receiver's antenna will reduce the radio reception sensitivity and range, and may cause a crash.

#### Servo throw

- ⚠ Adjust your system so that pushrods will not bind or sag when operating the servos to the full extent.

\*If excessive force is continuously applied to a servo, your aircraft may crash because the servo would be damaged and the battery would be consumed rapidly.

#### Mounting servos

- ⚠ Use a vibration-proof rubber (such as rubber grommet) under a servo when mounting the servo on a servo mount. And be sure that the servo cases do not touch directly to the metal parts such as servo mount.

\*If a servo case is contacting directly to the airframe, the vibration of the airframe directly travels to and may damage the servo.

## S.BUS Installation

This set uses the S.BUS system. The wiring is simplified and clean mounting is possible even with models that use a large number of servos. In addition, the wings can be quickly installed to the fuselage without any erroneous wiring by connecting only one wire even when there are many servos at the main wings.

- When the S.BUS is used special setting at the transmitter is unnecessary.
- The S.BUS servos and S.BUS gyros memorize the number of channels themselves. (Settable with the T18MZ)
- The S.BUS system and conventional system (receiver conventional CH used) can be mixed.

S.BUS Glider Usage example

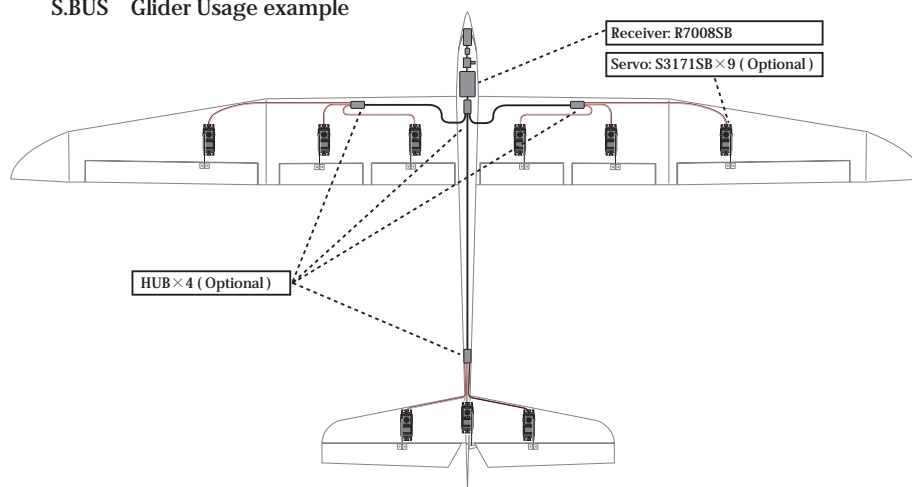

S.BUS F3A Airplane Usage example

