

LED Indication	
Status	LINK LED
No signal reception	Red Solid
Receiving signals	Green Solid
Waiting for link	Start → 2second later → Red Blink (3 second)
Unrecoverable error (EEPROM, etc.)	Red Green Alternate blink

In Dual RX Link Mode	
Status	MODE LED
External receiver is receiving error or not connected. S.BUS signal not received	Red Solid
S.BUS signal reception from external receiver (also received by external receiver)	Green Solid

In FASSTest12CH Telemetry OFF Mode	
Status	LINK LED
Start	Orange Solid

Link

FASSTest is a bidirectional communication system between the R7314SB receiver and FASSTest capable transmitters. Multiple optional telemetry sensors may be connected to the S.BUS2 on the receiver and that data is in turn displayed on the transmitter.

Link to the transmitter

- Bring the transmitter and the receiver close to each other, within 20 inches (half meter).
- Turn on the transmitter. Place the transmitter into the receiver linking mode.
- Turn on the receiver.
- The receiver will wait for the linking process to begin for 2 seconds. Following that it will return to the normal operation mode.
- When the LED of the receiver changes from blinking red to solid green, linking is complete. (A link waiting state is ended in 3 second.)
 - Refer to the transmitter's operation manual for complete details on how to place the transmitter into the linking mode.
 - If there are many FASSTest systems turned on in close proximity, your receiver might have difficulty establishing a link to your transmitter. This is a rare occurrence. However, should another FASSTest transmitter/receiver be linking at the same time, your receiver could link to the wrong transmitter. This is very dangerous if not noticed. To avoid the problem, we strongly recommend that you double check whether your receiver is really under control by your transmitter.
 - If the System Type of the transmitter is changed, the receiver will need to be re-linked to the transmitter.

S.BUS2

S.BUS2 extends S.BUS and supports bidirectional communication. Sensors are connected to the S.BUS2 port.

Compliance Information Statement (for Canada)

This device complies with Industry Canada license-exempt RSS standard(s). Operation is subject to the following two conditions: (1) this device may not cause interference, and (2) this device must accept any interference, including interference that may cause undesired operation of the device. This equipment complies with IC radiation exposure limits set forth for an uncontrolled environment. This equipment should be installed and operated with minimum distance 20cm between the radiator & your body.
 French: Cet appareil radio est conforme au CNR-210 d'Industrie Canada. L'utilisation de ce dispositif est autorisée seulement aux deux conditions suivantes: (1) il ne doit pas produire de brouillage, et (2) l'utilisateur du dispositif doit être prêt à accepter tout brouillage radioélectrique reçu, même s'il est susceptible de compromettre le fonctionnement du dispositif. Cet équipement est conforme aux limites d'exposition aux rayonnements IC établies pour un environnement non contrôlé. Cet équipement est conforme aux limites d'exposition aux rayonnements IC établies pour un environnement non contrôlé. Cet équipement doit être installé et utilisé avec un minimum de 20 cm de distance entre la source de rayonnement et votre corps.

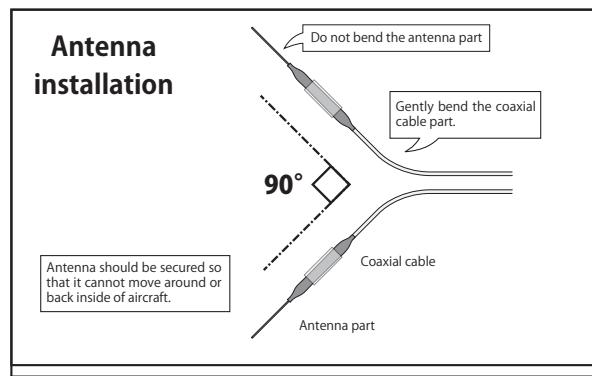

Channel Modes

The R7314SB is capable of changing its channel allocations as described in the table below. This is especially important when using the receiver in a dual receiver mode. See your transmitter operation manual for complete details on operating in the dual receiver mode.

R7314SB CH Mode table

Port	Channel							
	Mode A	Mode B	Mode C	Mode D	Mode E	Mode F	Mode G	Mode H
1	1	1	1	1	13	13	13	13
2	2	2	2	2	14	14	14	14
3	3	3	3	3	15	15	15	15
4	4	4	4	4	16	16	16	16
5	5	5	5	5	17	17	17	17
6	6	6	6	6	18	18	18	18
7	7	7	7	7	19	19	19	19
8	8	8	8	8	20	20	20	20
9	9	9	9	9	21	21	21	21
10	10	10	10	10	22	22	22	22
11	11	11	11	11	23	23	23	23
12	12	12	12	12	24	24	24	24
SB2/DG1	DG1	SB2	DG1	SB2	DG1	SB2	DG1	SB2
SB/DG2	DG2	SB	DG2	SB	DG2	SB	DG2	SB



Default

- Turn on the receiver. [Transmitter is always OFF]
- Press and hold the SW for 5 seconds to 10 seconds.
- When the LED of the receiver changes from blinking red to blinking orange, SW is released.
- The LED should now blink red two times in the patterns described in the chart below.
- Each press of the SW advances the receiver to the next mode.
- When you reach the mode that you wish to operate in, press and hold the SW for more than 2 seconds. When LED blinks in orange, it is the completion of a mode change, SW is released.
- Cycle the receiver power off and back on again after changing the Channel mode.



LINK LED

- Turn on the receiver. [Transmitter is always OFF]
- Receiver enters link waiting state
- The LED will flash for the current CH output mode.

Red Solid

Start → 2second later → Red Blink (3 second)

Current CH mode display

Dual Rx Link System

By installing two receivers in one aircraft, if one receiver becomes unable to communicate, the other receiver can be operated.

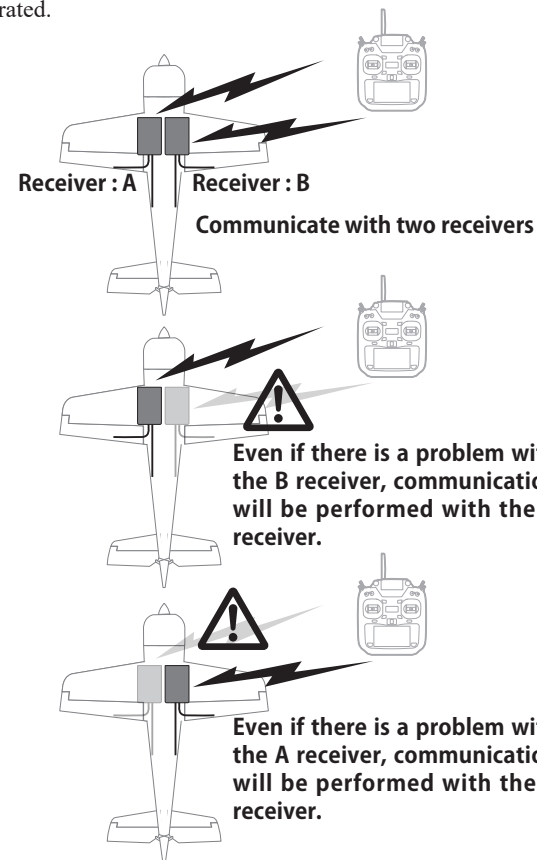

In Dual RX link mode, the SB2/RX port is for reception only, so use separate ports for S.BUS output and S.BUS2 input/output.

Connection example

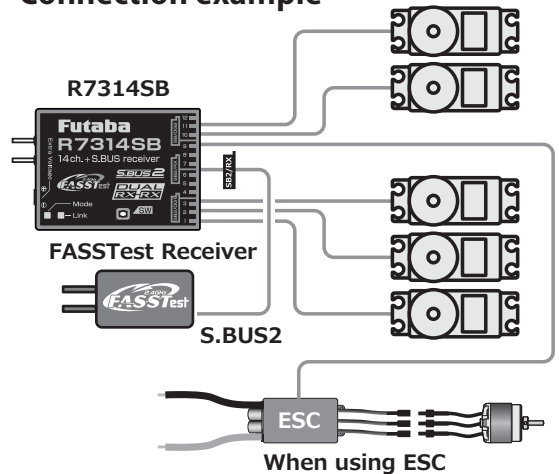

低功率射頻器材技術規範警語

取得審驗證明之低功率射頻器材，非經核准，公司、商號或使用者均不得擅自變更頻率、加大功率或變更原設計之特性及功能。低功率射頻器材之使用不得影響飛航安全及干擾合法通信；經發現有干擾現象時，應立即停用，並改善至無干擾時方得繼續使用。前述合法通信，指依電信管理法規作業之無線電通信。低功率射頻器材須忍受合法通信或工業、科學及醫療用電波輻射性電機設備之干擾。

Declaration of Conformity (for EU)

Hereby, Futaba Corporation declares that the radio equipment type is R7314SB in compliance with Directive 2014/53/EU. The full text of the EU declaration of conformity is available at the following internet address: <https://www.rc.futaba.co.jp/support/manual/>

How to change to Dual RX Link mode

- Turn on the receiver. [Transmitter is always OFF]
- Press and hold the SW for 5 seconds or more.

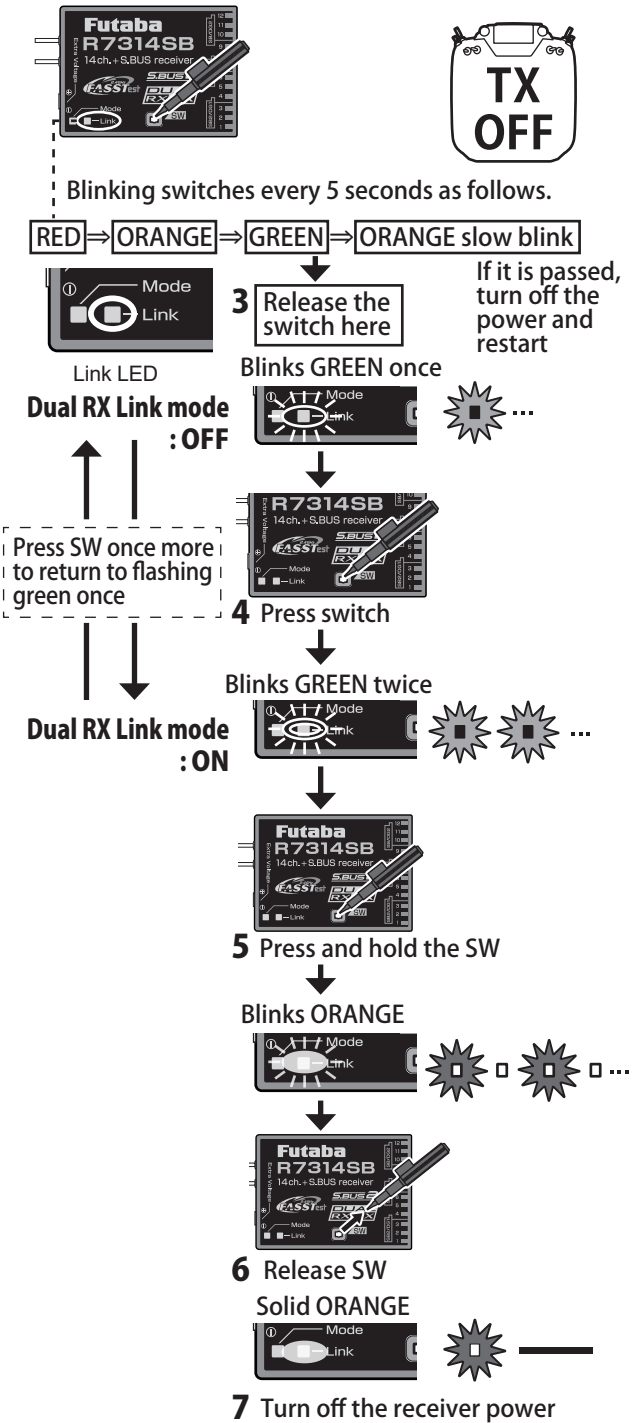

After restarting, the MODE LED lights up. Solid ORANGE



Status	MODE LED
External receiver is receiving error or not connected. S.BUS signal not received	Red Solid
S.BUS signal reception from external receiver (also received by external receiver)	Green Solid