

(Revised Version)
APPLICATION FOR CERTIFICATION
Class II Permissive Change
On Behalf of
Futaba Corporation
RF-Modem using digital modulation
Model : FRH-SD07TU
FCC ID : AZP-FRH-SD07TU

Prepared for : Futaba Corporation
1080, Yabuzuka Chosei-son Chosei-gun
Chiba-ken, 299-4395 Japan.

Prepared by : Audix Corporation
No. 53-11, Tin-Fu Tsun, Lin-Kou,
Taipei Hsien, Taiwan, R.O.C.

Tel : (02) 2609-9301, 2609-2133
Fax: (02) 2609-9303

File Number : EM940100
Report Number : EM-F940060
Date of Test : Mar. 05 ~ Apr. 13, 2005
Date of Report : Apr. 14, 2005

TABLE OF CONTENTS

Description	Page
TEST REPORT CERTIFICATION.....	3
1. GENERAL INFORMATION.....	4
1.1. Description of Device (EUT)	4
1.2. Tested Supporting System Details	5
1.3. Description of Test Facility	6
1.4. Measurement Uncertainty.....	7
2. CONDUCTED EMISSION MEASUREMENT.....	8
2.1. Test Equipment.....	8
2.2. Block Diagram of Test Setup.....	8
2.3. Conducted Emission Limit (§15.207).....	8
2.4. Operating Condition of EUT	9
2.5. Test Procedure	9
2.6. Conducted Emission Measurement Results.....	9
3. RADIATED EMISSION MEASUREMENT	16
3.1. Test Equipment.....	16
3.2. Test Setup.....	16
3.3. Radiated Emission Limits (§15.209)	17
3.4. Operating Condition of EUT	17
3.5. Test Procedure	18
3.6. Radiated Emission Measurement Results	18
4. DEVIATION TO TEST SPECIFICATIONS.....	100
5. PHOTOGRAPHS.....	101
5.1. Photos of Conducted Emission Measurement.....	101
5.2. Photos of Radiated Measurement at Semi-Anechoic Chamber (30-1000MHz)	106
5.3. Photos of Radiated Measurement at Semi-Anechoic Chamber (Above 1 GHz)	111

TEST REPORT CERTIFICATION (Class II Permissive Change)

Applicant : Futaba Corporation
 Manufacturer : Futaba Corporation
 EUT Description : RF-Modem using digital modulation
 FCC ID : AZP-FRH-SD07TU
 (A) MODEL NO. : FRH-SD07TU
 (B) SERIAL NO. : N/A
 (C) POWER SUPPLY : DC 2.7 ~ 3.3V
 (D) TEST VOLTAGE : AC 120V, 60Hz (Via PC System) or
 DC 3.9V (Via DC Power Supply)

Measurement Procedure Used:

FCC RULES AND REGULATIONS PART 15 SUBPART C, JAN. 2005
 AND FCC / ANSI C63.4-2003 / Canada RSS-210
 (FCC CFR 47 Part 15C, §15.205, §15.207, §15.209 and §15.247)

The device described above was tested by AUDIX Corporation to determine the maximum emission levels emanating from the device. The maximum emission levels were compared to the FCC Part 15 subpart C limits and regulations.

The measurement results are contained in this test report and AUDIX Corporation is assumed full responsibility for the accuracy and completeness of these measurements. Also, this report shows that the EUT to be technically compliant with the FCC official limits.

This report applies to above tested sample only. This report shall not be reproduced in part without written approval of AUDIX Corporation.

Date of Test : Mar. 05 ~ Apr. 13, 2005

Prepared by : Tina Huang Apr. 22, 2005
 (Tina Huang/Assistant)

Test Engineer : Ben Cheng Apr. 22, 2005
 (Ben Cheng/Section Manager)

Approve & Authorized Signer : Leon Liu Apr. 22 2005
 (Leon Liu/Senior Manager)

1. GENERAL INFORMATION

1.1. Description of Device (EUT)

Description	:	RF-Modem using digital modulation
Model Number	:	FRH-SD07TU
FCC ID	:	AZP-FRH-SD07TU
Applicant	:	Futaba Corporation 1080, Yabuzuka Chosei-son Chosei-gun Chiba-ken, 299-4395 Japan.
Manufacturer	:	Futaba Corporation 1080, Yabuzuka Chosei-son Chosei-gun Chiba-ken, 299-4395 Japan.
Fundamental Range	:	2420MHz ~ 2473MHz
Antenna Gain	:	2.14dBi (For all Antennas)
Frequency Channel	:	54 channels (54 individual frequencies between 2420MHz and 2473MHz with 1MHz/2MHz separation in each frequency)
Test Frequency	:	2420MHz, 2450MHz, 2473MHz.
Date of Receipt of Sample	:	Jan. 24, 2005
Date of Test	:	Mar. 05 ~ Apr. 13, 2005

Remark:

This EUT is an upgrade version of original FCC ID AZP-FRH-SD07TU. The differences are to add five kinds of new antennas (SMA Connector), the RF-Modem is identical with original. Added five antennas are as follows:

- (1) Pencil type antenna, gray
- (2) Pedestal base with flexible type antenna element, black
- (3) Pedestal base with rigid type antenna element (This is for outside use), black
- (4) Flat type, two CoAx cables, for diversity reception
- (5) Flat type, single CoAx cable, for single reception

1.2. Tested Supporting System Details

1.2.1. PERSONAL COMPUTER

Model Number : VECTRA XE320
 Serial Number : SG21102005
 FCC ID : By DoC
 BSMI ID : 3912A318
 Manufacturer : First International Computer, Inc.
 (Brand: HP)
 Power Cord : Non-Shielded, Detachable, 1.8m

1.2.2. LCD MONITOR

Model Number : D5063
 Serial Number : CN206A6034
 FCC ID : ARSLM562H
 BSMI ID : R33037
 Manufacturer : Top Victory Electronics (Fujian) Co., Ltd.
 Data Cable (D-Sub) : Shielded, Detachable, 1.8m
 Bonded two ferrite cores
 Audio Cable(*2EA) : Non-Shielded, Detachable, 1.2m
 AC Adapter : Delta, M/N ADP-40TB
 BSMI ID 3892D142
 Cord: Shielded, Undetachable, 1.8m
 Bonded a ferrite core
 Power Cord : Non-Shielded, Detachable, 1.8m

1.2.3. KEYBOARD

Model Number : SK-2502C
 Serial Number : M020236422
 FCC ID : By DoC
 BSMI ID : 3872F107
 Manufacturer : Silitek (Brand: HP)
 Data Cable : Non-Shielded, Undetachable, 1.8m

1.2.4. DOT MATRIX PRINTER (For Conducted and Radiated Emission Measurement)

Model Number : KX-P2135
 Serial Number : 8DMCN02139
 FCC ID : ACJ5Z6KX-P2135
 BSMI ID : 3872A371
 Manufacturer : Matsushita (Brand: Panasonic)
 Data Cable : Shielded, Detachable, 1.5m
 Power Cord : Non-Shielded, Detachable, 1.8m

1.2.5. PS2 MOUSE

Model Number : M-S48a
 Serial Number : LZE20501577
 FCC ID : JNZ201213
 BSMI ID : 4882A001
 Manufacturer : Logitech (Brand: HP)
 Data Cable : Non-Shielded, Undetachable, 1.8m

1.2.6. DC POWER SUPPLY

Model Number : 3303A
 Serial Number : 721773
 Manufacturer : TOP WARD
 DC Power Cord*2 : Non-Shielded, Detachable, 0.3m

1.2.7. PCB INTERFACE CARD

Model Number : Futaba
 Serial Number : N/A
 Manufacturer : PCBIT087
 RS-232 Cable : Non-Shielded, Detachable, 1.8m

1.3. Description of Test Facility

Name of Firm : **AUDIX Corporation**
 Technical Division EMC Department
 No. 53-11, Tin-Fu Tsun, Lin-Kou,
 Taipei County, Taiwan, R.O.C.

Test Facility : **No. 2 Shielding Room**
 No. 53-11, Tin-Fu Tsun, Lin-Kou,
 Taipei Hsien, Taiwan, R.O.C.

Semi-Anechoic Chamber
 No. 53-11, Tin-Fu Tsun, Lin-Kou,
 Taipei Hsien, Taiwan, R.O.C.

May 16, 2003 Re-File on
 Federal Communication Commission
 Registration Number: 90993

NVLAP Lab. Code : 200077-0
 (NVLAP is a NATA accredited body under Mutual Recognition Agreement)

DAR-Registration No. : DAT-P-145/03-01

1.4. Measurement Uncertainty

Test Item	Frequency Range	Uncertainty
Conduction Test	150kHz~30MHz	±1.73dB
Radiation Test (Distance: 3m)	30MHz~300MHz	± 2.91dB
	300MHz~1000MHz	± 2.94dB
	Above 1000MHz	± 5.02dB

Remark : Uncertainty = $k_{uc}(y)$

2. CONDUCTED EMISSION MEASUREMENT

2.1. Test Equipment

The following test equipment are used during the power line conducted tests :

Item	Type	Manufacturer	Model No.	Serial No.	Last Cal.	Next Cal.
1.	Test Receiver	R & S	ESCS30	100265	Oct. 05, 04'	Oct. 04, 05'
2.	L.I.S.N. # 1	Kyoritsu	KNW-407	8-855-9	Apr. 20, 04'	Apr. 19, 05'
3.	L.I.S.N.	Kyoritsu	KNW-407	8-881-13	Apr. 20, 04'	Apr. 19, 05'
4.	Pulse Limiter	R & S	ESH3Z2	001	Apr. 28, 04'	Apr. 27, 05'

2.2. Block Diagram of Test Setup

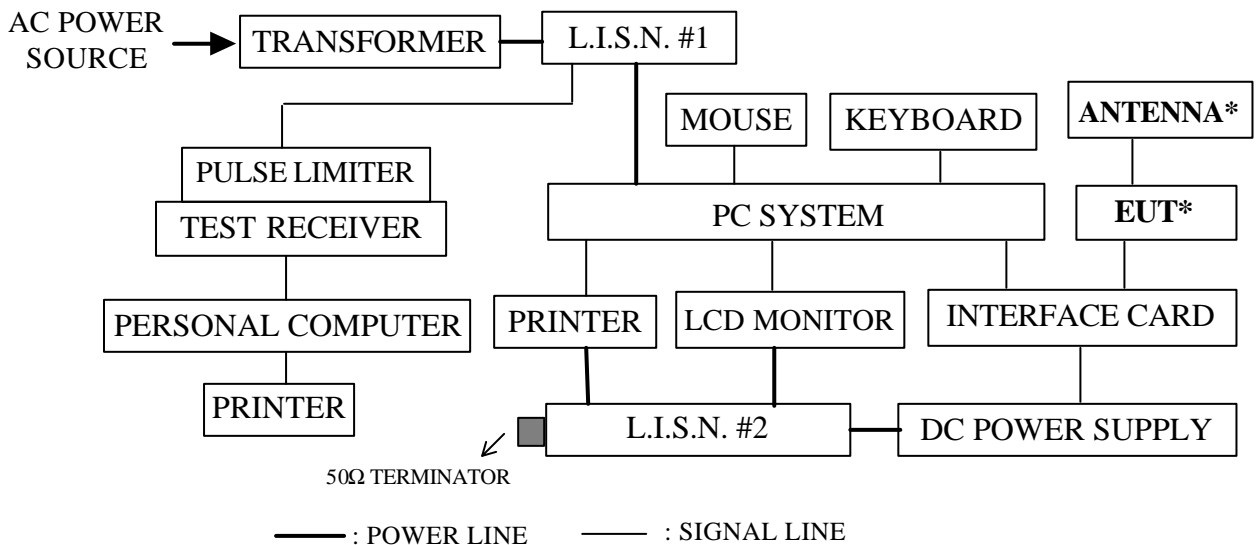

***EUT: RF-MODEM USING DIGITAL MODULAT**

2.3. Conducted Emission Limit (§15.207)

Frequency	Maximum RF Line Voltage (dBμV)	
	Quasi-Peak Level	Average Level
150kHz ~ 500kHz	66 ~ 56 dBμV*	56 ~ 46 dBμV*
500kHz ~ 5MHz	56 dBμV	46 dBμV
5MHz ~ 30MHz	60 dBμV	50 dBμV

- Remark:
- * Decreases with the logarithm of the frequency.
 - If the average limit is met when using a Quasi-Peak detector, the EUT shall be deemed to meet both limits and measurement with the average detector is unnecessary.

2.4. Operating Condition of EUT

- 2.4.1. Setup the EUT and simulator as shown on 2.2.
- 2.4.2. Turned on the power of all equipment.
- 2.4.3. The PC system running the test program “Futaba Term” was used to enable the EUT to transmit and receive data at frequency 2450MHz during all testing.

2.5. Test Procedure

The EUT and simulator was put on table which was above the ground by 80cm, EUT was powered by interface card and then the interface card was linked to PC system, through the PC’s power cord connected to the power mains through a line impedance stabilization network (L.I.S.N. #1) and the other peripheral devices power cord were connected to the power mains through a line impedance stabilization network (L.I.S.N. #2) This provided a 50 ohm coupling impedance for the measuring equipment. (Please refer to the block diagram of the test setup and photographs.)

Both sides of A.C. line were checked for maximum conducted interference. In order to find the maximum emission, the relative positions of equipment and all of the interface cables were changed according to FCC ANSI C63.4-2003 on conducted measurement.

The bandwidth of the R&S Test Receiver ESCS30 was set at 9kHz.

The frequency range from 150kHz to 30MHz was pre-scanned with a peak detector.

The all final readings from test receiver were measured were with the Quasi-Peak detector and Average detector. (Remark: If the Average limit is met when using a Quasi-Peak detector, the Average detector is unnecessary)

2.6. Conducted Emission Measurement Results

PASSED. All emissions not reported below are too low against the prescribed limits.

EUT with different antenna modes were performed during conducted testing and selected the worst mode (Mode 1) to read Q.P. value, all the test results are listed in next pages.

EUT : RF-Modem using digital modulation M/N : FRH-SD07TU

(Test Date: Mar. 08, 2005 Temperature : 16 Humidity : 59 %)

Mode	Antenna	Reference Test Data #	
		Neutral	Line
1.	Pencil type antenna	# 2	# 1
2.	Pedestal base with flexible type antenna	# 4	# 3
3.	Pedestal base with rigid type antenna	# 6	# 5
4.	Flat type, two CoAx cables	# 8	# 7
5.	Flat type, single CoAx cable	# 10	# 9

(**mode for maximum detected emission**)



AUDIX Corp. EMC Laboratory
 No.53-11, Tin-fu Tsun, Lin-kou Hsiang, Taipei
 County, Taiwan R.O.C. Post Code:24443
 Tel:02-26092133 Fax:02-26099303
 Email:ttemc@ttemc.com.tw

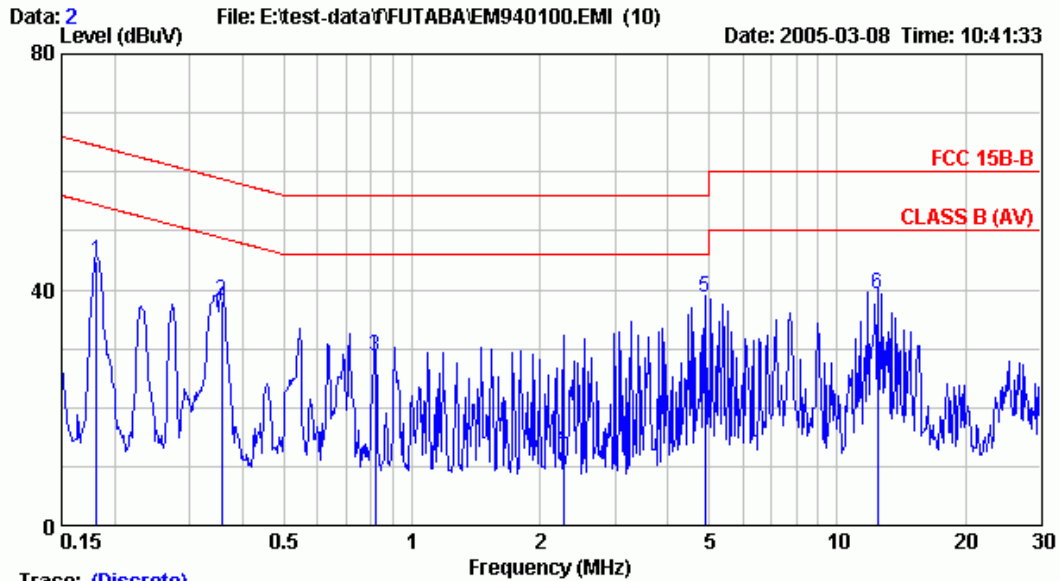

Trace: (Discrete)

Site : No.2 Shielded room Data : 2
 Condition : KNW-407 Phase : NEUTRAL
 Limit : FCC 15B-B
 Env. / Ins. : 16°C,59% / ESCS 30 Engineer: Cater Chou
 EUT : RF-Modem using digital modulation
 Power Rating : 120Vac/60Hz M/N:FRH-SD07TU
 Test Mode : TX-2450MHz (ANT-1)

	LISN	Cable	Emission		Limits	Margin	Remark
Freq. (MHz)	Factor (dB)	Loss (dB)	Reading (dB μV)	Level (dB μV)	(dB μV)	(dB)	
1	0.182	0.23	44.22	44.70	64.42	19.71	QP
2	0.357	0.12	37.79	38.22	58.80	20.58	QP
3	0.820	0.10	28.20	28.68	56.00	27.32	QP
4	2.273	0.10	12.70	13.20	56.00	42.80	QP
5	4.890	0.10	38.24	38.80	56.00	17.20	QP
6	12.426	0.15	38.34	39.19	60.00	20.81	QP

Remarks: 1. Emission Level= LISN Factor + Cable Loss + Reading.
 2. If the average limit is met when using a quasi-peak detector, the EUT shall be deemed to meet both limits and measurement with average detector is unnecessary.
 3. The worst emission was detected at 4.890MHz with corrected signal level of 38.80dBmV (limit is 56.00dBmV) when the Neutral Phase of the PC's power was connected to LISN.



AUDIX Corp. EMC Laboratory
 No.53-11, Tin-fu Tsun, Lin-kou Hsiang, Taipei
 County, Taiwan R.O.C. Post Code:24443
 Tel:02-26092133 Fax:02-26099303
 Email:ttemc@ttemc.com.tw

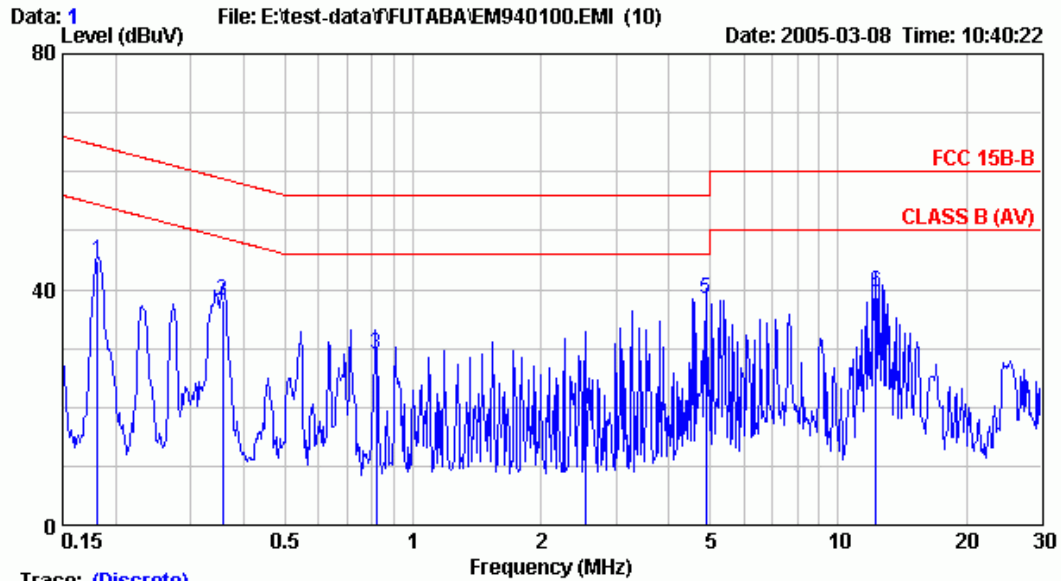

Trace: (Discrete)

Site : No.2 Shielded room Data : 1
 Condition : KMW-407 Phase : LINE
 Limit : FCC 15B-B
 Env. / Ins. : 16°C,59% / ESCS 30 Engineer: Cater Chou
 EUT : RF-Modem using digital modulation
 Power Rating : 120Vac/60Hz M/N:FRH-SD07TU
 Test Mode : TX-2450MHz (ANT-1)

	LISN	Cable	Emission		Limits	Margin	Remark
Freq. (MHz)	Factor (dB)	Loss (dB)	Reading (dB μV)	Level (dB μV)	(dB μV)	(dB)	
1	0.23	0.25	44.26	44.74	64.42	19.67	QP
2	0.12	0.31	37.77	38.20	58.81	20.61	QP
3	0.10	0.38	28.46	28.94	56.00	27.06	QP
4	0.10	0.40	19.06	19.56	56.00	36.44	QP
5	0.12	0.46	37.66	38.25	56.00	17.75	QP
6	0.20	0.70	38.63	39.53	60.00	20.47	QP

Remarks: 1.Emission Level= LISN Factor + Cable Loss + Reading.
 2.If the average limit is met when using a quasi-peak detector ,the EUT shall be deemed to meet both limits and measurement with average detector is unnecessary.
 3. The worst emission was detected at 4.894MHz with corrected signal level of 38.25dBmV (limit is 56.00dBmV) when the Line Phase of the PC's power was connected to LISN.



AUDIX Corp. EMC Laboratory
 No.53-11, Tin-fu Tsun, Lin-kou Hsiang, Taipei
 County, Taiwan R.O.C. Post Code:24443
 Tel:02-26092133 Fax:02-26099303
 Email:ttemc@ttemc.com.tw

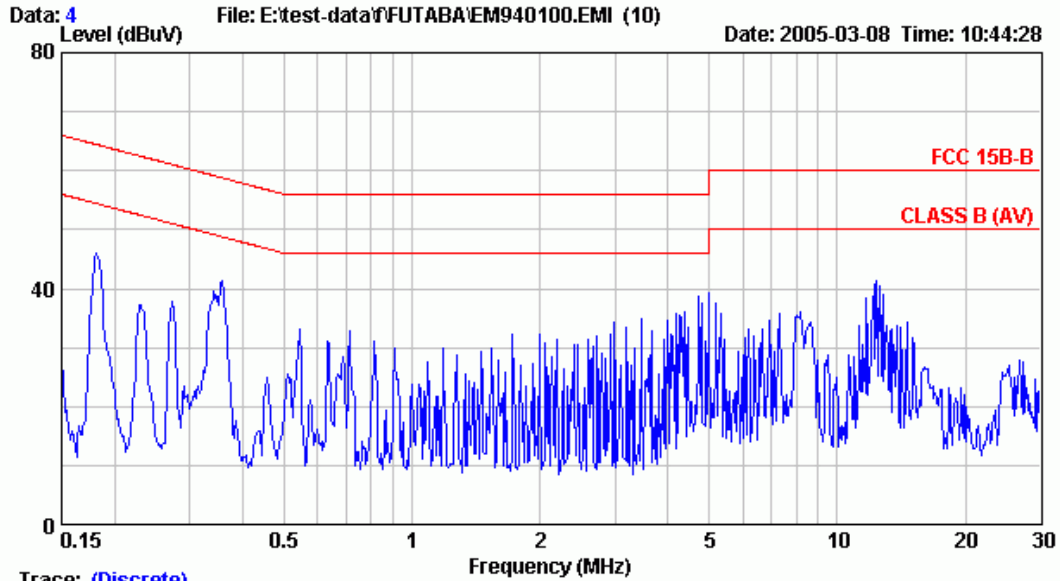

Trace: (Discrete)

Site	: No.2 Shielded room	Data	: 4
Condition	: KNW-407	Phase	: NEUTRAL
Limit	: FCC 15B-B		
Env. / Ins.	: 16°C,59% / ESCS 30	Engineer:	Cater Chou
EUT	: RF-Modem using digital modulation		
Power Rating	: 120Vac/60Hz	M/N:	FRH-SD07TU
Test Mode	: TX-2450MHz	(ANT-2)	

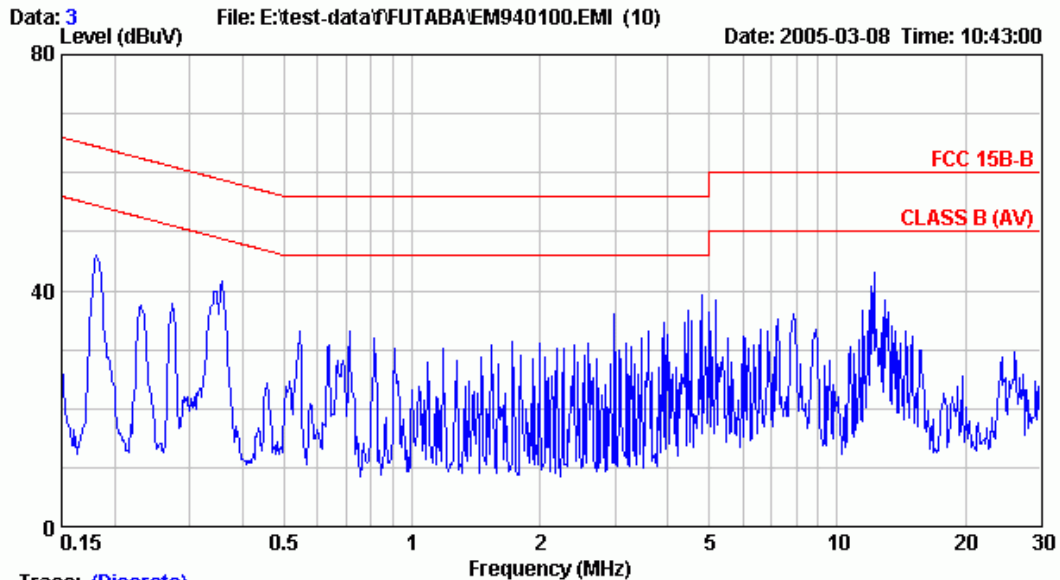

Trace: (Discrete)

Site	: No.2 Shielded room	Data	: 3
Condition	: KNW-407	Phase	: LINE
Limit	: FCC 15B-B		
Env. / Ins.	: 16°C,59% / ESCS 30	Engineer:	Cater Chou
EUT	: RF-Modem using digital modulation		
Power Rating	: 120Vac/60Hz	M/N:	FRH-SD07TU
Test Mode	: TX-2450MHz	(ANT-2)	



AUDIX Corp. EMC Laboratory
 No.53-11, Tin-fu Tsun, Lin-kou Hsiang, Taipei
 County, Taiwan R.O.C. Post Code:24443
 Tel:02-26092133 Fax:02-26099303
 Email:ttemc@ttemc.com.tw

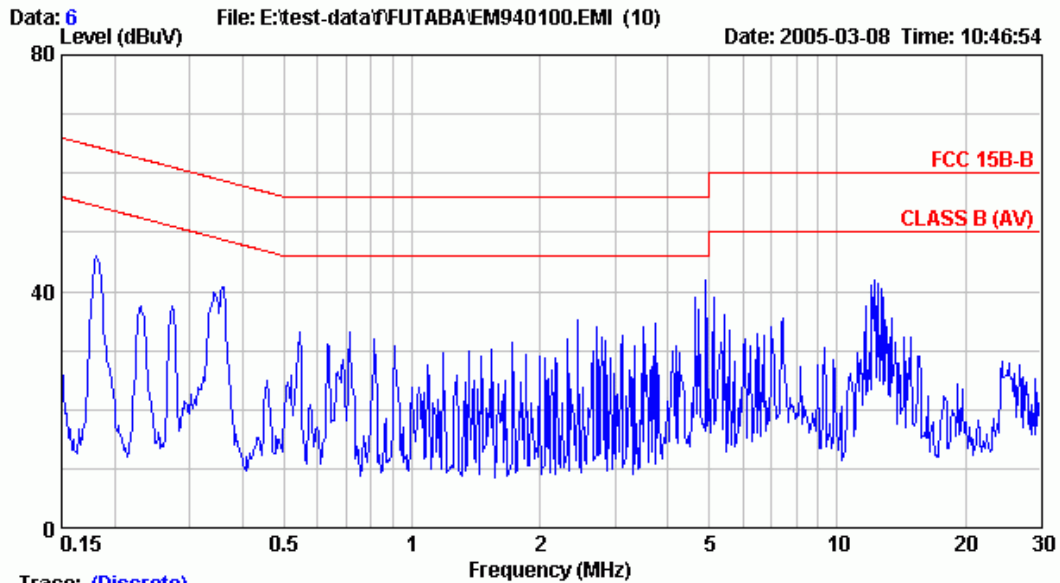

Trace: (Discrete)
 Site : No.2 Shielded room Data : 6
 Condition : KNW-407 Phase : NEUTRAL
 Limit : FCC 15B-B
 Env. / Ins. : 16°C,59% / ESCS 30 Engineer: Cater Chou
 EUT : RF-Modem using digital modulation
 Power Rating : 120Vac/60Hz M/N:FRH-SD07TU
 Test Mode : TX-2450MHz (ANT-3)

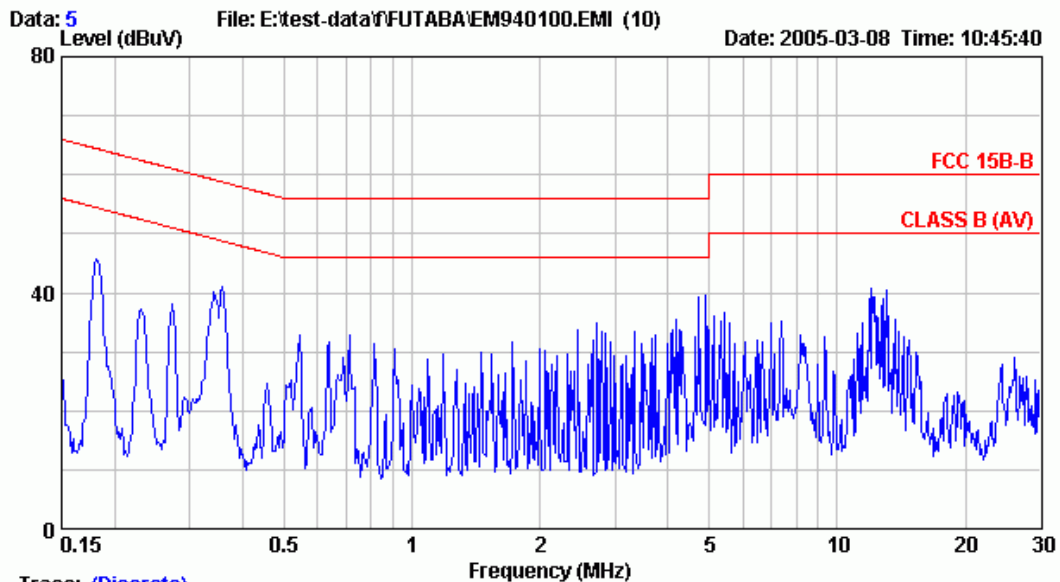

Trace: (Discrete)
 Site : No.2 Shielded room Data : 5
 Condition : KNW-407 Phase : LINE
 Limit : FCC 15B-B
 Env. / Ins. : 16°C,59% / ESCS 30 Engineer: Cater Chou
 EUT : RF-Modem using digital modulation
 Power Rating : 120Vac/60Hz M/N:FRH-SD07TU
 Test Mode : TX-2450MHz (ANT-3)



AUDIX Corp. EMC Laboratory
 No.53-11, Tin-fu Tsun, Lin-kou Hsiang, Taipei
 County, Taiwan R.O.C. Post Code:24443
 Tel:02-26092133 Fax:02-26099303
 Email:ttemc@ttemc.com.tw

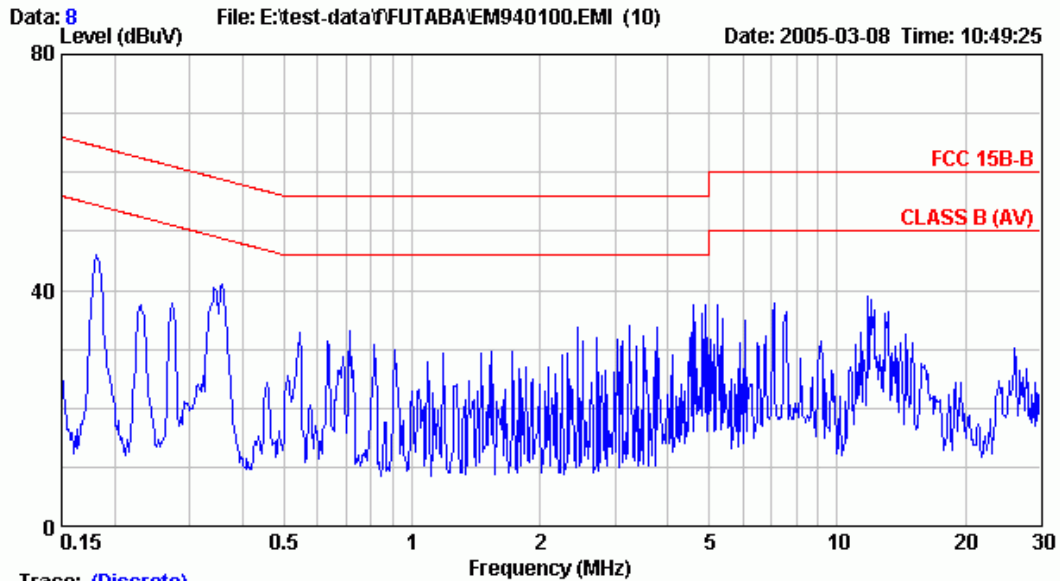

Trace: (Discrete)

Site	: No.2 Shielded room	Data	: 8
Condition	: KNW-407	Phase	: NEUTRAL
Limit	: FCC 15B-B		
Env. / Ins.	: 16°C,59% / ESCS 30	Engineer:	Cater Chou
EUT	: RF-Modem using digital modulation		
Power Rating	: 120Vac/60Hz	M/N:	FRH-SD07TU
Test Mode	: TX-2450MHz	(ANT-4)	

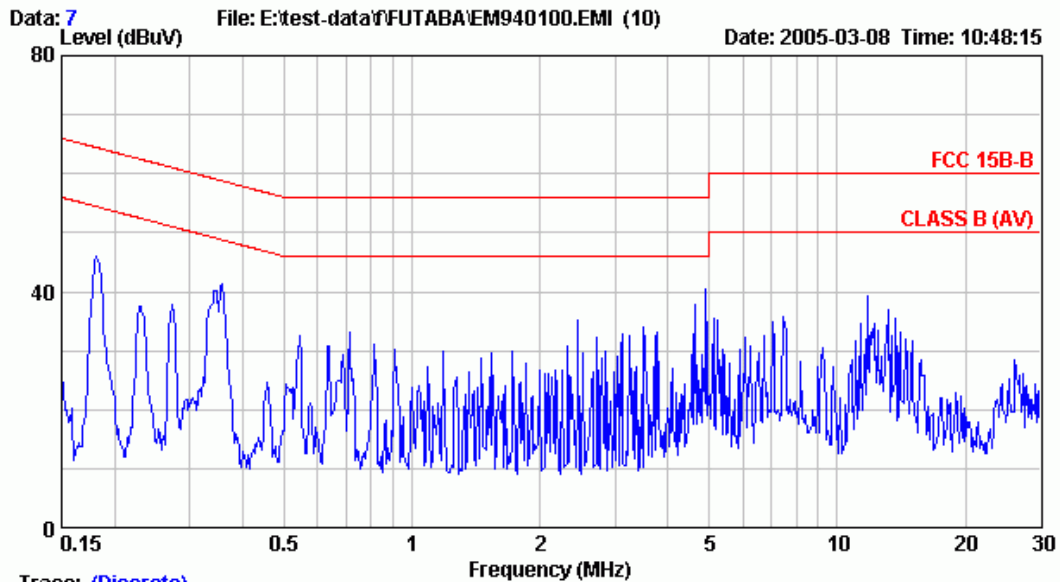

Trace: (Discrete)

Site	: No.2 Shielded room	Data	: 7
Condition	: KNW-407	Phase	: LINE
Limit	: FCC 15B-B		
Env. / Ins.	: 16°C,59% / ESCS 30	Engineer:	Cater Chou
EUT	: RF-Modem using digital modulation		
Power Rating	: 120Vac/60Hz	M/N:	FRH-SD07TU
Test Mode	: TX-2450MHz	(ANT-4)	



AUDIX Corp. EMC Laboratory
 No.53-11, Tin-fu Tsun, Lin-kou Hsiang, Taipei
 County, Taiwan R.O.C. Post Code:24443
 Tel:02-26092133 Fax:02-26099303
 Email:ttemc@ttemc.com.tw

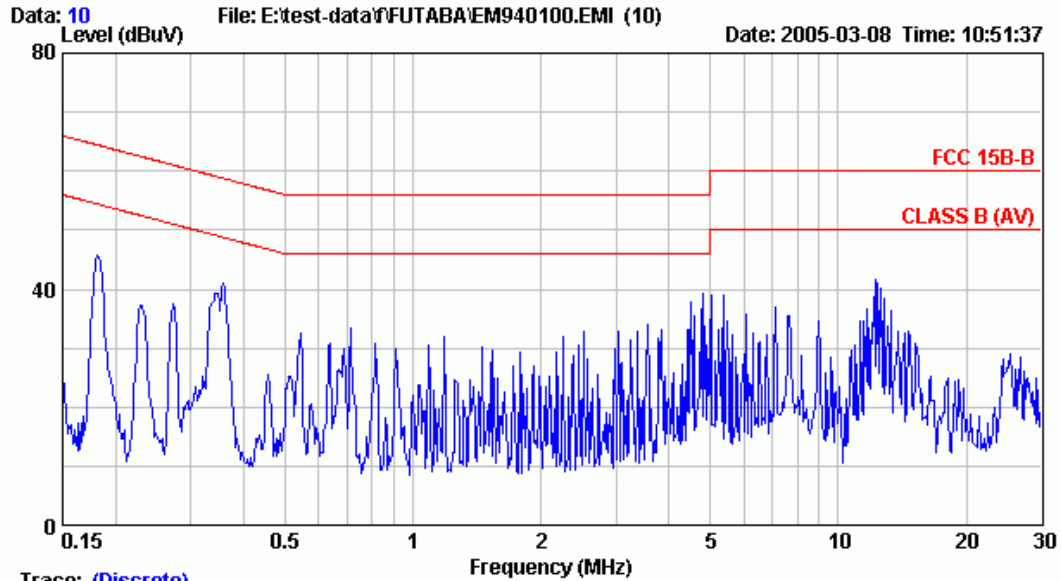

Trace: (Discrete)

Site	: No.2 Shielded room	Data	: 10
Condition	: KNW-407	Phase	: NEUTRAL
Limit	: FCC 15B-B		
Env. / Ins.	: 16°C,59% / ESCS 30	Engineer:	Cater Chou
EUT	: RF-Modem using digital modulation		
Power Rating	: 120Vac/60Hz	M/N:	FRH-SD07TU
Test Mode	: TX-2450MHz	(ANT-5)	

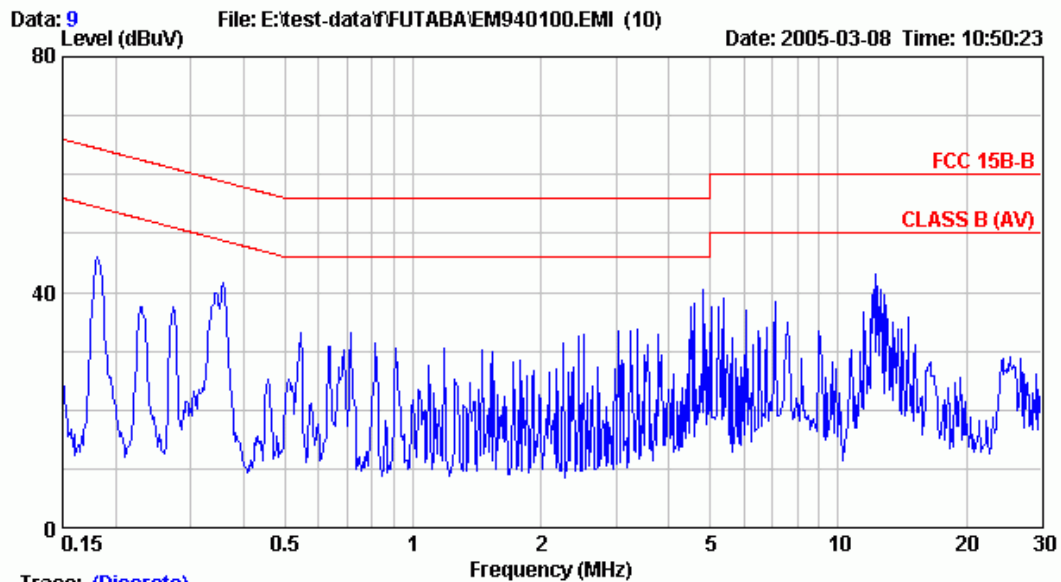

Trace: (Discrete)

Site	: No.2 Shielded room	Data	: 9
Condition	: KNW-407	Phase	: LINE
Limit	: FCC 15B-B		
Env. / Ins.	: 16°C,59% / ESCS 30	Engineer:	Cater Chou
EUT	: RF-Modem using digital modulation		
Power Rating	: 120Vac/60Hz	M/N:	FRH-SD07TU
Test Mode	: TX-2450MHz	(ANT-5)	

3. RADIATED EMISSION MEASUREMENT

3.1. Test Equipment

The following test equipment are used during the radiated emission tests :

3.1.1. 30MHz~1000MHz Frequency

Item	Type	Manufacturer	Model No.	Serial No.	Last Cal.	Next Cal.
1.	Spectrum Analyzer	Agilent	E4446A	US44300366	Aug. 27, 04'	Aug. 26. 05'
2.	Pre-Amplifier	HP	8447D	2944A06305	Mar.18, 04'	Mar.17, 05'
3.	Broadband Antenna	Schwarzbeck	BBA 9106	A3L	Feb.18, 04'	Feb.17, 05'
4.	Broadband Antenna	Schwarzbeck	UHALP9108-A	0139	Dec.14, 04'	Dec.13, 05'

3.1.2. Above 1GHz frequency

Item	Type	Manufacturer	Model No.	Serial No.	Last Cal.	Next Cal.
1.	Spectrum Analyzer	Agilent	E4446A	US44300366	Aug. 27, 04'	Aug. 26. 05'
2.	Amplifier	HP	8449B	3008A00529	Jan. 14, 05'	Jan. 13, 05'
3.	Horn Antenna	EMCO	3115	9112-3775	May 05, 04'	May 04, 05'
4.	Horn Antenna	EMCO	3116	2653	Nov. 03, 04'	Nov. 04, 05'
5.	High Pass Filter	HP	84300-80038	005	Jan.13, 05'	Jan.12, 06'

3.2. Test Setup

3.2.1. Block Diagram of connection between EUT and simulators

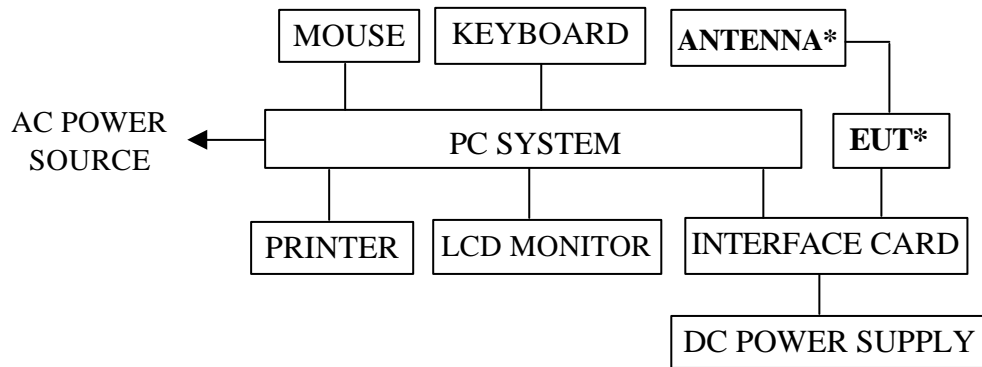

3.2.2. Semi-Anechoic Chamber (3m) Setup Diagram

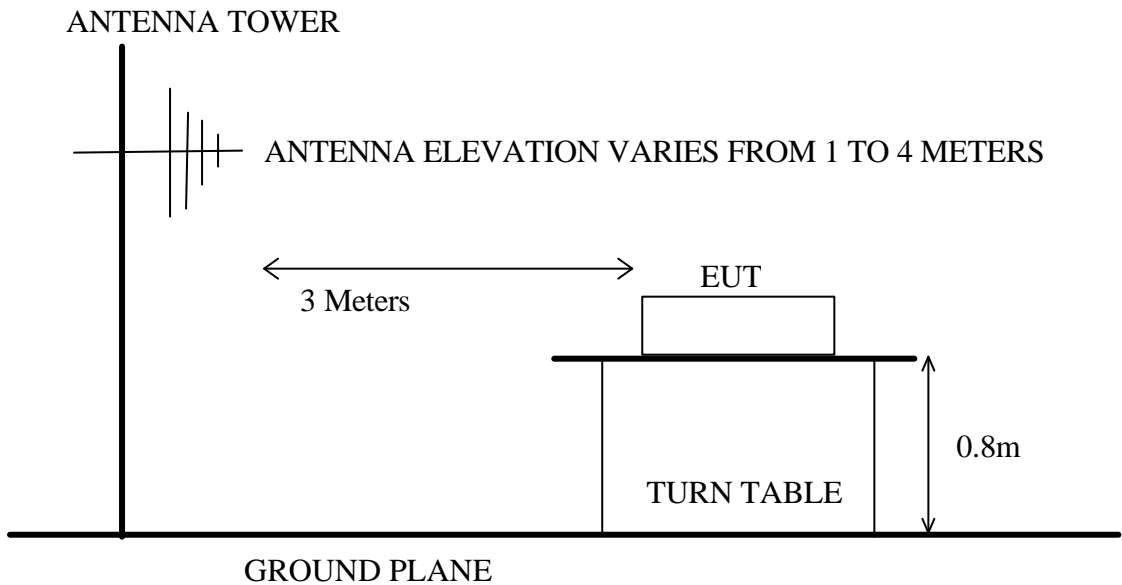

3.3. Radiated Emission Limits (§15.209)

FREQUENCY MHz	DISTANCE Meters	FIELD STRENGTHS LIMITS	
		μV/m	dBμV/m
30 ~ 88	3	100	40.0
88 ~ 216	3	150	43.5
216 ~ 960	3	200	46.0
Above 960	3	500	54.0
Above 1000(*5)	3	74.0 dBμV/m (Peak) 54.0 dBμV/m (Average)	

- Remark :
- (1) Emission level (dBμV/m) = 20 log Emission level (μV/m)
 - (2) The tighter limit applies at the edge between two frequency bands.
 - (3) Distance refers to the distance in meters between the measuring instrument antenna and the closed point of any part of the device or system.
 - (4) The limits in this table are based on CFR 47 Part 15.205(a)(b) and Part 15.209 (a).
 - (4) The over 1GHz limit, FCC limit is used based on CFR 47 Part 15.35 (b) and Part 15.205(b) & Part 15.209(e) and Part 15.207(c).

3.4. Operating Condition of EUT

The configuration of EUT and its simulators are same as those used in conducted measurement. Please refer to 2.4.

3.5. Test Procedure

The EUT and its simulators were placed on a turn table which was 0.8 meter above the ground. The turn table rotated 360 degrees to determine the position of the maximum emission level. EUT was set 3 meters away from the receiving antenna which was mounted on a antenna tower. The antenna moved up and down between 1 to 4 meters to find out the maximum emission level. Broadband antenna such as calibrated biconical and log- periodical antenna or horn antenna were used as a receiving antenna. Both horizontal and vertical polarization of the antenna were set on measurement. In order to find the maximum emission, all of the interface cables were manipulated according to FCC ANSI C63.4-2003 regulation.

The bandwidth of the R&S Test Receiver ESVS10 was set at 120kHz. (For 30MHz to 1000MHz)

The resolution bandwidth of the Agilent Spectrum Analyzer E4446A was set at 1MHz. (For Above 1GHz)

The frequency range from 30MHz to 18GHz was checked

3.6. Radiated Emission Measurement Results

PASSED.

(All the emissions not reported below are too low against the prescribed limits.)

For 30MHz~1000MHz frequency range:

EUT with different antenna and frequency modes were performed during radiated testing and all the test results are listed in section 3.6.1.

Mode	Antenna	Operation	Frequency	Reference Test Data #	
				Horizontal	Vertical
1.	Pencil type antenna	Transmitting	2420MHz	# 12	# 11
2.			2450MHz	# 12	# 11
3.			2473MHz	# 10	# 09
4.		Receiving	2420MHz	# 11	# 12
5.	Pedestal base with flexible type antenna	Transmitting	2420MHz	# 12	# 11
6.			2450MHz	# 12	# 11
7.			2473MHz	# 11	# 12
8.		Receiving	2420MHz	# 12	# 11
9.	Pedestal base with rigid type antenna	Transmitting	2420MHz	# 14	# 13
10.			2450MHz	# 14	# 13
11.			2473MHz	# 11	# 12
12.		Receiving	2420MHz	# 11	# 12
13.	Flat type, two CoAx cables	Transmitting	2420MHz	# 13	# 14
14.			2450MHz	# 13	# 14
15.			2473MHz	# 12	# 11
16.		Receiving	2420MHz	# 13	# 14
17.	Flat type, single CoAx cable	Transmitting	2420MHz	# 12	# 11
18.			2450MHz	# 11	# 12
19.			2473MHz	# 12	# 11
20.		Receiving	2420MHz	# 14	# 13

* Above all final readings were measured with Quasi-Peak detector.

For 1GHz~25GHz frequency range:

EUT with different antenna and frequency modes were performed during radiated testing and all the test results are listed in section 3.6.2.

Mode	Antenna	Operation	Frequency
1.	Pencil type antenna	Transmitting	2420MHz
2.			2450MHz
3.			2473MHz
4.		Receiving	2420MHz
5.	Pedestal base with flexible type antenna	Transmitting	2420MHz
6.			2450MHz
7.			2473MHz
8.		Receiving	2420MHz
9.	Pedestal base with rigid type antenna	Transmitting	2420MHz
10.			2450MHz
11.			2473MHz
12.		Receiving	2420MHz
13.	Flat type, two CoAx cables	Transmitting	2420MHz
14.			2450MHz
15.			2473MHz
16.		Receiving	2420MHz
17.	Flat type, single CoAx cable	Transmitting	2420MHz
18.			2450MHz
19.			2473MHz
20.		Receiving	2420MHz

* Above all final readings were measured with Peak detector and Average detector.

For Restricted Bands:

The EUT with following test mode were done during restricted bands and all the test results are listed in section 3.6.3. (The restricted bands defined in part 15.205(a))

Mode	Antenna	Frequency
1.	Pencil type antenna	(1) 2420MHz (2) 2473MHz
2.	Pedestal base with flexible type antenna	
3.	Pedestal base with rigid type antenna	
4.	Flat type, two CoAx cables	
5.	Flat type, single CoAx cable	

3.6.1. 30MHz to 1000MHz Frequency Range Measurement Results



EMC Laboratory
 No.53-11, Tin-fu Tsun, Lin-kou Hsiang, Taipei
 County, Taiwan R.O.C. Post Code:24443
 Tel:+886-2-26092133 Fax:+886-2-26099303
 Email:ttemc@ttemc.com.tw

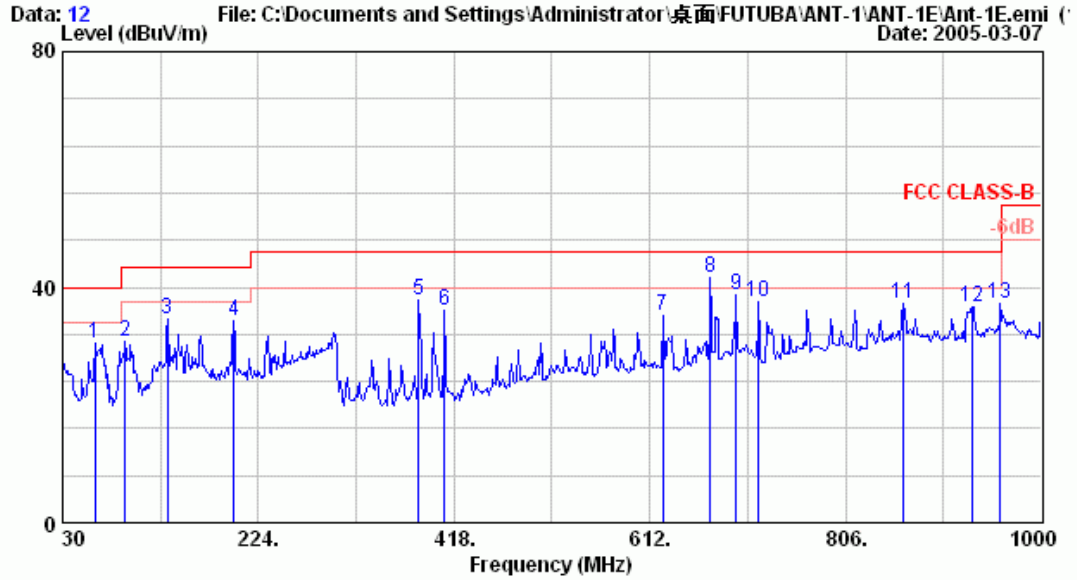

Site : A/C Chamber Date : 12
 Condition : 3m BBA9106/UHALP9108-A Polarity: HORIZONTAL
 Limit : FCC CLASS-B
 Env. / Ins. : 8593EM 18*C/62% Engineer: henning
 EUT : RF-Modem using digital modulation
 Power Rating : DC 3.9V M/N:FRH-SD07TU
 Test Mode : TX (2420MHz)---ANT1

	Ant.	Cable	Emission					
Freq. (MHz)	Factor (dB/m)	Loss (dB)	Reading (dBuV)	Level (dBuV/m)	Limits (dBuV/m)	Margin (dB)	Remark	
1	12.28	1.60	16.72	30.61	40.00	9.39		
2	16.08	2.00	12.71	30.78	43.50	12.72		
3	19.89	2.40	12.31	34.60	43.50	8.90		
4	22.09	3.00	9.12	34.21	43.50	9.29		
5	17.33	4.62	15.80	37.76	46.00	8.24		
6	17.28	4.90	13.79	35.96	46.00	10.04		
7	21.31	6.20	7.74	35.25	46.00	10.75		
8	22.85	6.40	12.26	41.52	46.00	4.48		
9	23.32	6.50	9.00	38.82	46.00	7.18		
10	22.30	6.60	8.75	37.65	46.00	8.35		
11	26.09	7.20	3.89	37.18	46.00	8.82		
12	25.11	7.50	4.04	36.65	46.00	9.35		
13	26.38	7.60	3.13	37.12	46.00	8.88		

Remarks: 1. Emission Level= Antenna Factor + Cable Loss + Reading.
 2. The emission levels that are 20dB below the official limit are not reported.



EMC Laboratory
 No.53-11, Tin-fu Tsun, Lin-kou Hsiang, Taipei
 County, Taiwan R.O.C. Post Code:24443
 Tel:+886-2-26092133 Fax:+886-2-26099303
 Email:ttemc@ttemc.com.tw

Data: 11 File: C:\Documents and Settings\Administrator\桌面\FUTUBA\ANT-1\ANT-1E\Ant-1E.emi (' Date: 2005-03-07

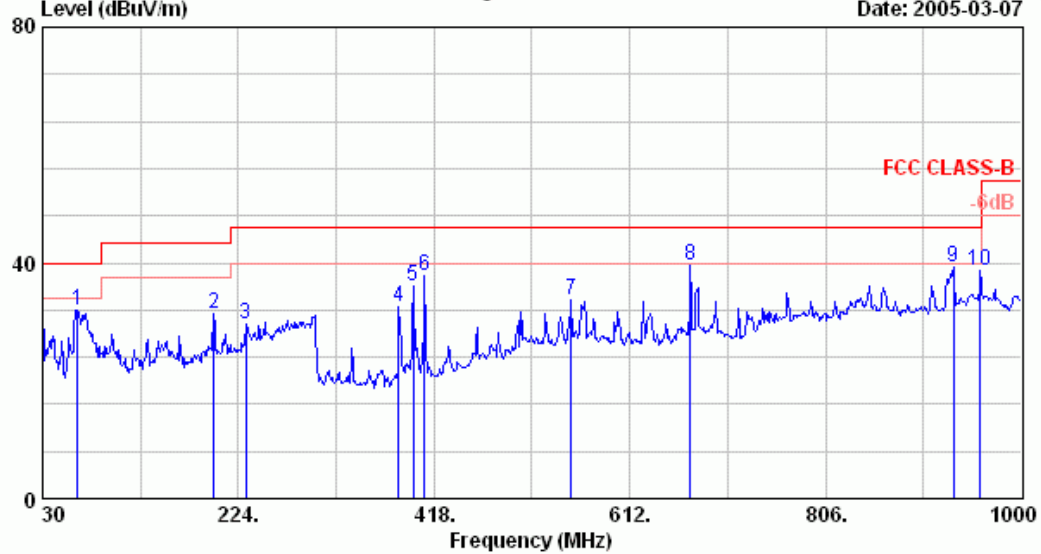

Site : A/C Chamber Date : 11
 Condition : 3m BBA9106/UHALP9108-A Polarity: VERTICAL
 Limit : FCC CLASS-B
 Env. / Ins. : 8593EM 18°C/62% Engineer: henning
 EUT : RF-Modem using digital modulation
 Power Rating : DC 3.9V M/N:FRH-SD07TU
 Test Mode : TX (2420MHz)---ANT1

Freq. (MHz)	Ant. Factor (dB/m)	Cable Loss (dB)	Reading (dBuV)	Emission		Margin (dB)	Remark
				Level (dBuV/m)	Limits (dBuV/m)		
1	12.84	1.70	17.42	31.96	40.00	8.04	
2	22.86	3.00	5.42	31.28	43.50	12.22	
3	24.33	3.30	1.96	29.59	46.00	16.41	
4	17.08	4.62	10.87	32.57	46.00	13.43	
5	17.67	4.80	13.51	35.98	46.00	10.02	
6	17.15	4.90	15.65	37.70	46.00	8.30	
7	21.88	6.80	4.98	33.66	46.00	12.34	
8	23.07	6.40	10.19	39.67	46.00	6.33	
9	26.27	7.50	5.50	39.27	46.00	6.73	
10	27.16	7.60	4.01	38.77	46.00	7.23	

Remarks: 1. Emission Level= Antenna Factor + Cable Loss + Reading.
 2. The emission levels that are 20dB below the official limit are not reported.



EMC Laboratory
 No.53-11, Tin-fu Tsun, Lin-kou Hsiang, Taipei
 County, Taiwan R.O.C. Post Code:24443
 Tel:+886-2-26092133 Fax:+886-2-26099303
 Email:ttenc@ttenc.com.tw

Data: 12 File: C:\Documents and Settings\Administrator\桌面\FUTUBA\ANT-1\ANT-1(M)\Ant-1E(M).e Date: 2005-03-07

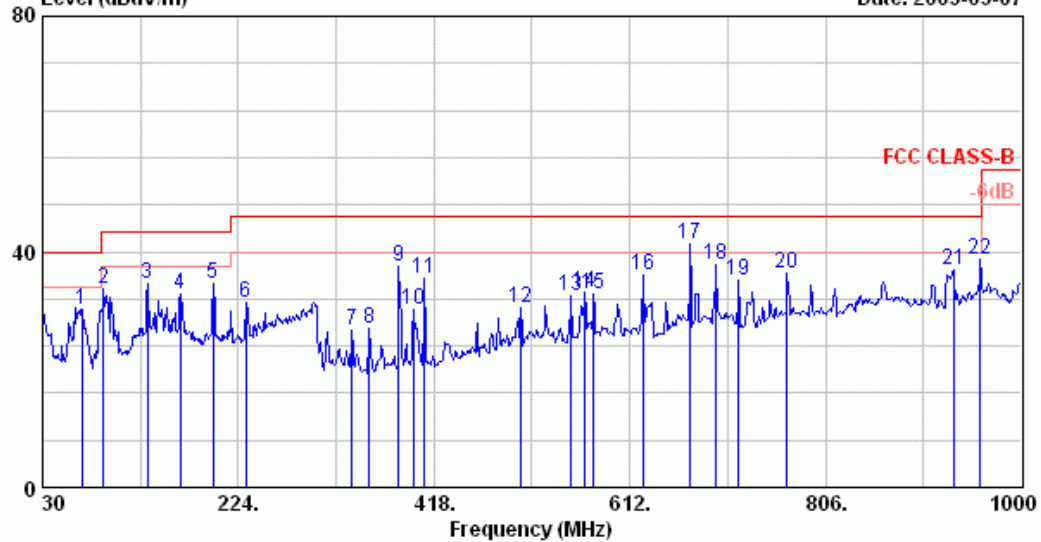

Site : A/C Chamber Date : 12
 Condition : 3m BBA9106/UHALP9108-A Polarity: HORIZONTAL
 Limit : FCC CLASS-B
 Env. / Ins. : 8593EM 18*C/62% Engineer: henning
 EUT : RF-Modem using digital modulation
 Power Rating : DC 3.9V M/N:FRH-SD07TU
 Test Mode : TX (2450MHz)---ANT1

Ant. Freq. (MHz)	Factor (dB/m)	Cable Loss (dB)	Reading (dBuV)	Emission Level (dBuV/m)	Limits (dBuV/m)	Margin (dB)	Remark
1	11.93	1.70	16.67	30.30	40.00	9.70	
2	15.77	2.00	16.00	33.77	43.50	9.73	
3	19.89	2.40	12.29	34.58	43.50	8.92	
4	20.96	2.70	9.14	32.80	43.50	10.70	
5	22.07	3.00	9.56	34.63	43.50	8.87	
6	22.25	3.30	5.87	31.41	46.00	14.59	
7	15.08	4.20	7.46	26.75	46.00	19.25	
8	15.64	4.30	7.11	27.05	46.00	18.95	
9	17.33	4.62	15.62	37.58	46.00	8.42	
10	17.64	4.80	7.81	30.25	46.00	15.75	
11	17.28	4.90	13.22	35.39	46.00	10.61	
12	19.02	6.62	4.94	30.58	46.00	15.42	
13	19.40	6.80	6.19	32.39	46.00	13.61	
14	20.97	6.50	5.54	33.02	46.00	12.98	
15	21.05	6.40	5.33	32.78	46.00	13.22	
16	21.31	6.20	8.62	36.13	46.00	9.87	
17	22.85	6.40	11.94	41.20	46.00	4.80	
18	23.32	6.50	7.98	37.80	46.00	8.20	
19	22.30	6.60	6.36	35.26	46.00	10.74	
20	23.87	6.80	5.71	36.38	46.00	9.62	
21	25.23	7.50	4.14	36.87	46.00	9.13	
22	26.38	7.60	4.76	38.75	46.00	7.25	

Remarks: 1. Emission Level= Antenna Factor + Cable Loss + Reading.
 2. The emission levels that are 20dB below the official limit are not reported.



EMC Laboratory
 No.53-11, Tin-fu Tsun, Lin-kou Hsiang, Taipei
 County, Taiwan R.O.C. Post Code:24443
 Tel:+886-2-26092133 Fax:+886-2-26099303
 Email:ttenc@ttenc.com.tw

Data: 11 File: C:\Documents and Settings\Administrator\桌面\FUTUBA\ANT-1\ANT-1(M)\Ant-1E(M).e Date: 2005-03-07
 Level (dBuV/m)

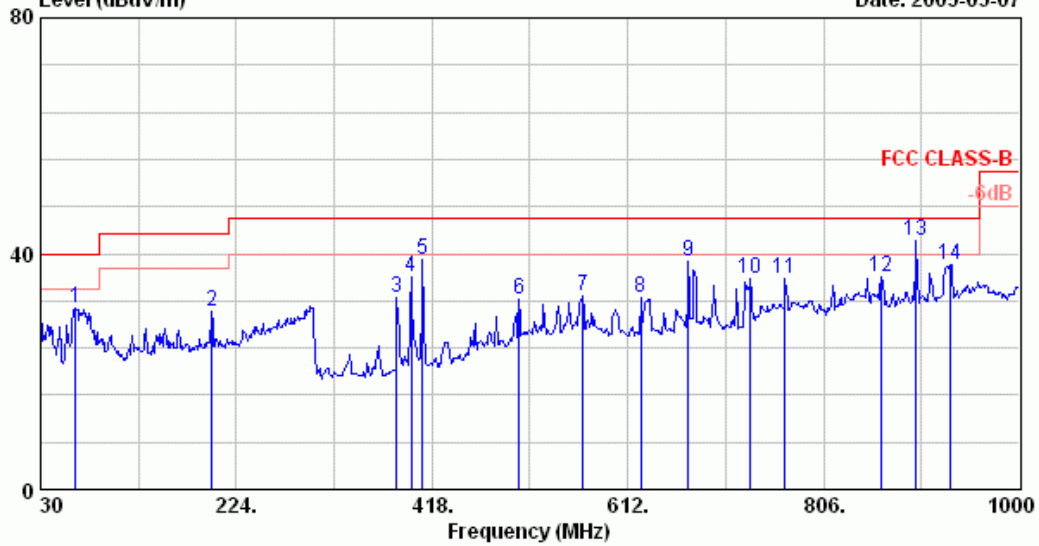

Site : A/C Chamber Date : 11
 Condition : 3m BBA9106/UHALP9108-A Polarity: VERTICAL
 Limit : FCC CLASS-B
 Env. / Ins. : 8593EM 18°C/62% Engineer: henning
 EUT : RF-Modem using digital modulation
 Power Rating : DC 3.9V M/N:FRH-SD07TU
 Test Mode : TX (2450MHz)---ANT1

Ant. Freq. (MHz)	Cable Factor (dB/m)	Cable Loss (dB)	Emission Reading (dBuV)	Emission Level (dBuV/m)	Limits (dBuV/m)	Margin (dB)	Remark
1	12.84	1.70	16.24	30.78	40.00	9.22	
2	22.86	3.00	4.25	30.11	43.50	13.39	
3	17.08	4.62	10.87	32.57	46.00	13.43	
4	17.67	4.80	13.71	36.18	46.00	9.82	
5	17.15	4.90	16.84	38.89	46.00	7.11	
6	20.21	6.62	5.41	32.23	46.00	13.77	
7	22.08	6.50	4.36	32.94	46.00	13.06	
8	21.15	6.20	5.23	32.58	46.00	13.42	
9	23.07	6.40	9.13	38.61	46.00	7.39	
10	22.98	6.70	6.12	35.80	46.00	10.20	
11	24.98	6.80	4.08	35.87	46.00	10.13	
12	25.46	7.20	3.32	35.98	46.00	10.02	
13	25.86	7.30	8.93	42.08	46.00	3.92	
14	26.22	7.50	4.30	38.02	46.00	7.98	

Remarks: 1. Emission Level= Antenna Factor + Cable Loss + Reading.
 2. The emission levels that are 20dB below the official limit are not reported.



EMC Laboratory
 No.53-11, Tin-fu Tsun, Lin-kou Hsiang, Taipei
 County, Taiwan R.O.C. Post Code:24443
 Tel:+886-2-26092133 Fax:+886-2-26099303
 Email:ttenc@ttenc.com.tw

Data: 10 File: C:\Documents and Settings\Administrator\桌面\ANT-H\ANT-1(H)\ANT-1EE\Ant-1E(H).e Date: 2005-04-13
 Level (dBuV/m)

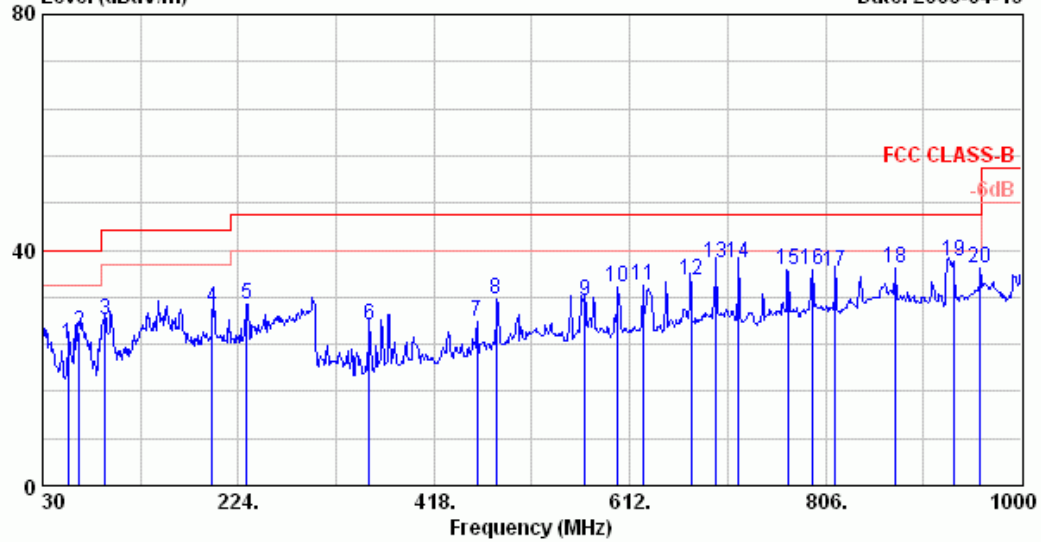

Site : A/C Chamber Date : 10
 Condition : 3m BBA9106/UHALP9108-A Polarity: HORIZONTAL
 Limit : FCC CLASS-B
 Env. / Ins. : 8593EM 21°C/59% Engineer: henning
 EUT : RF-Modem using digital modulation
 Power Rating : DC 3.9V M/N:FRH-SD07TU
 Test Mode : TX (2473MHz)---ANT1

Freq. (MHz)	Ant. Factor (dB/m)	Cable Loss (dB)	Reading (dBuV)	Emission Level (dBuV/m)	Limits (dBuV/m)	Margin (dB)	Remark
1	14.39	1.50	8.11	24.00	40.00	16.00	
2	11.78	1.70	12.49	25.97	40.00	14.03	
3	16.08	2.00	10.05	28.12	43.50	15.38	
4	22.07	3.00	5.25	30.32	43.50	13.18	
5	22.25	3.30	5.35	30.90	46.00	15.10	
6	15.64	4.30	7.23	27.17	46.00	18.83	
7	17.93	5.70	4.30	27.92	46.00	18.08	
8	18.68	6.05	6.95	31.68	46.00	14.32	
9	20.97	6.50	3.98	31.46	46.00	14.54	
10	21.31	6.30	6.01	33.62	46.00	12.38	
11	21.31	6.20	6.58	34.09	46.00	11.91	
12	22.85	6.40	5.71	34.97	46.00	11.03	
13	23.32	6.50	7.98	37.80	46.00	8.20	
14	22.30	6.60	8.82	37.72	46.00	8.28	
15	23.87	6.80	5.94	36.61	46.00	9.39	
16	23.95	6.90	5.84	36.69	46.00	9.31	
17	23.89	7.00	5.43	36.32	46.00	9.68	
18	25.35	7.30	4.34	36.99	46.00	9.01	
19	25.23	7.50	5.43	38.16	46.00	7.84	
20	26.38	7.60	3.08	37.07	46.00	8.93	

Remarks: 1. Emission Level= Antenna Factor + Cable Loss + Reading.
 2. The emission levels that are 20dB below the official limit are not reported.



EMC Laboratory
 No.53-11, Tin-fu Tsun, Lin-kou Hsiang, Taipei
 County, Taiwan R.O.C. Post Code:24443
 Tel:+886-2-26092133 Fax:+886-2-26099303
 Email:ttemc@ttemc.com.tw

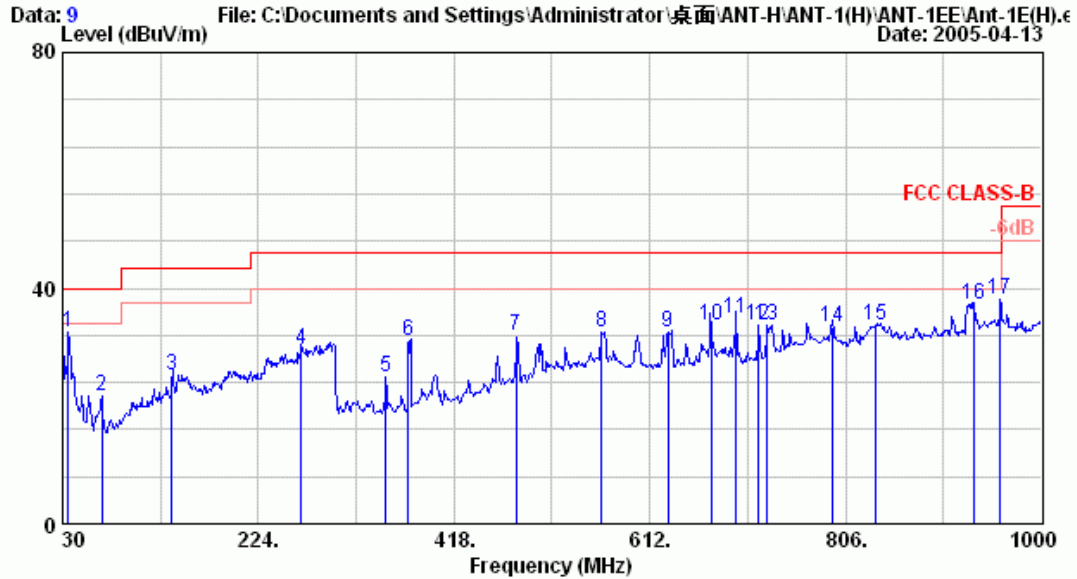

Site : A/C Chamber Date : 9
 Condition : 3m BBA9106/UHALP9108-A Polarity: VERTICAL
 Limit : FCC CLASS-B
 Env. / Ins. : 8593EM 21*C/59% Engineer: henning
 EUT : RF-Modem using digital modulation
 Power Rating : DC 3.9V M/N:FRH-SD07TU
 Test Mode : TX (2473MHz)---ANT1

	Ant. Factor	Cable Loss	Emission Reading	Emission Level	Limits	Margin	Remark
Freq. (MHz)	(dB/m)	(dB)	(dBuV)	(dBuV/m)	(dBuV/m)	(dB)	
1	21.79	1.20	9.47	32.46	40.00	7.54	
2	12.39	1.70	7.49	21.57	40.00	18.43	
3	19.13	2.50	3.60	25.23	43.50	18.27	
4	25.62	3.70	0.27	29.59	46.00	16.41	
5	15.73	4.30	4.85	24.89	46.00	21.11	
6	15.78	4.60	10.73	31.11	46.00	14.89	
7	18.94	6.05	6.83	31.81	46.00	14.19	
8	22.08	6.61	3.73	32.43	46.00	13.58	
9	21.09	6.40	5.16	32.65	46.00	13.35	
10	23.07	6.40	4.13	33.61	46.00	12.39	
11	22.93	6.50	5.55	34.98	46.00	11.02	
12	22.04	6.60	5.14	33.79	46.00	12.21	
13	22.41	6.60	4.65	33.66	46.00	12.34	
14	25.42	6.90	1.14	33.46	46.00	12.54	
15	26.42	7.10	0.29	33.81	46.00	12.19	
16	26.27	7.50	3.33	37.10	46.00	8.90	
17	27.16	7.60	3.37	38.13	46.00	7.87	

Remarks: 1. Emission Level= Antenna Factor + Cable Loss + Reading.
 2. The emission levels that are 20dB below the official limit are not reported.



EMC Laboratory
 No.53-11, Tin-fu Tsun, Lin-kou Hsiang, Taipei
 County, Taiwan R.O.C. Post Code:24443
 Tel:+886-2-26092133 Fax:+886-2-26099303
 Email:ttemc@ttemc.com.tw

Data: 11 File: C:\Documents and Settings\Administrator\桌面\FUTUBA\ANT-1\ANT-1-RX\Ant-1-rx.er Date: 2005-03-07

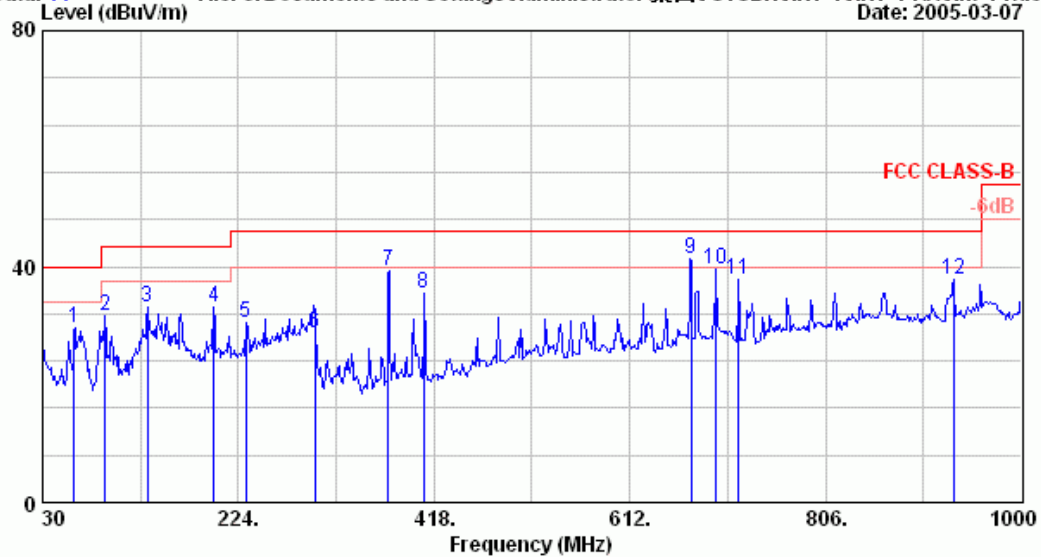

Site : A/C Chamber Date : 11
 Condition : 3m BBA9106/UHALP9108-A Polarity: HORIZONTAL
 Limit : FCC CLASS-B
 Env. / Ins. : 8593EM 18°C/62% Engineer: henning
 EUT : RF-Modem using digital modulation
 Power Rating : DC 3.9V M/N:FRH-SD07TU
 Test Mode : RX (2420MHz)---ANT1

Ant. Freq. (MHz)	Cable Factor (dB/m)	Cable Loss (dB)	Emission Reading (dBuV)	Emission Level (dBuV/m)	Limits (dBuV/m)	Margin (dB)	Remark
1	12.28	1.60	15.82	29.71	40.00	10.29	
2	16.08	2.00	13.54	31.61	43.50	11.89	
3	19.89	2.40	10.79	33.08	43.50	10.42	
4	22.09	3.00	8.10	33.19	43.50	10.31	
5	22.25	3.30	4.99	30.53	46.00	15.47	
6	26.77	3.90	-1.83	28.84	46.00	17.16	
7	17.12	4.60	17.67	39.40	46.00	6.60	
8	17.31	4.90	13.12	35.32	46.00	10.68	
9	22.85	6.40	12.19	41.45	46.00	4.55	
10	23.32	6.50	9.84	39.66	46.00	6.34	
11	22.30	6.60	8.84	37.74	46.00	8.26	
12	25.23	7.50	5.08	37.81	46.00	8.19	

Remarks: 1. Emission Level= Antenna Factor + Cable Loss + Reading.
 2. The emission levels that are 20dB below the official limit are not reported.



EMC Laboratory
 No.53-11, Tin-fu Tsun, Lin-kou Hsiang, Taipei
 County, Taiwan R.O.C. Post Code:24443
 Tel:+886-2-26092133 Fax:+886-2-26099303
 Email:ttenc@ttenc.com.tw

Data: 12 File: C:\Documents and Settings\Administrator\桌面\FUTUBA\ANT-1\ANT-1-RX\Ant-1-rx.er Date: 2005-03-07

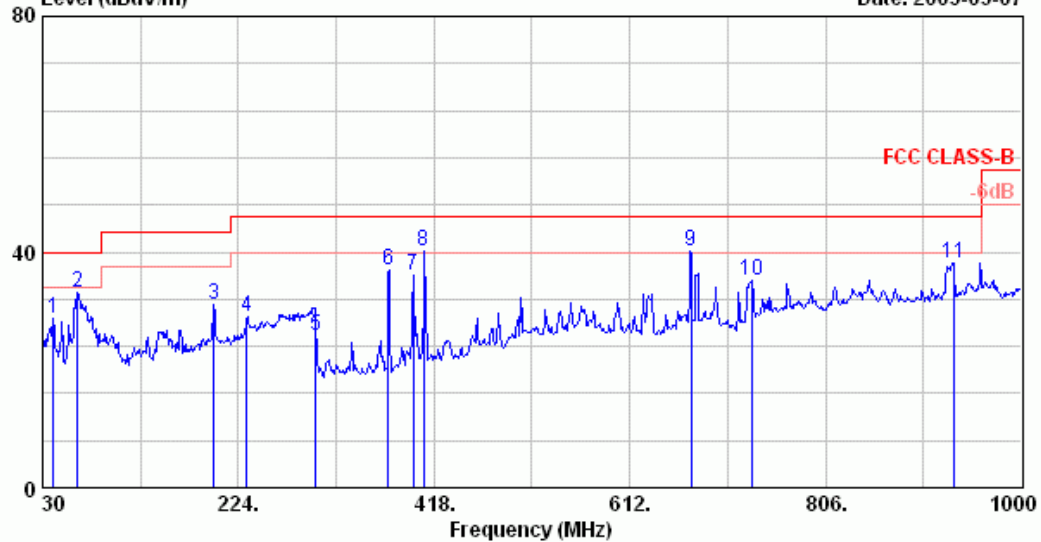

Site : A/C Chamber Date : 12
 Condition : 3m BBA9106/UHALP9108-A Polarity: VERTICAL
 Limit : FCC CLASS-B
 Env. / Ins. : 8593EM 18*C/62% Engineer: henning
 EUT : RF-Modem using digital modulation
 Power Rating : DC 3.9V M/N:FRH-SD07TU
 Test Mode : RX (2420MHz)---ANT1

	Ant.	Cable	Emission				
Freq. (MHz)	Factor (dB/m)	Loss (dB)	Reading (dBμV)	Level (dBμV/m)	Limits (dBμV/m)	Margin	Remark
1	40.530	20.33	1.30	7.17	28.80	40.00	11.20
2	64.830	12.84	1.70	18.54	33.08	40.00	6.92
3	199.830	22.86	3.00	5.24	31.10	43.50	12.40
4	232.230	24.33	3.30	1.29	28.93	46.00	17.07
5	300.700	14.75	3.90	7.19	25.84	46.00	20.16
6	372.800	15.78	4.60	16.62	37.00	46.00	9.00
7	397.300	17.67	4.80	13.64	36.11	46.00	9.89
8	407.800	17.19	4.90	18.01	40.10	46.00	5.90
9	672.400	23.07	6.40	10.66	40.14	46.00	5.86
10	733.300	22.98	6.70	5.51	35.19	46.00	10.81
11	932.800	26.27	7.50	4.37	38.14	46.00	7.86

Remarks: 1. Emission Level= Antenna Factor + Cable Loss + Reading.
 2. The emission levels that are 20dB below the official limit are not reported.



EMC Laboratory
 No.53-11, Tin-fu Tsun, Lin-kou Hsiang, Taipei
 County, Taiwan R.O.C. Post Code:24443
 Tel:+886-2-26092133 Fax:+886-2-26099303
 Email:ttenc@ttenc.com.tw

Data: 12 File: C:\Documents and Settings\Administrator\桌面\FUTUBA\ANT-2\ANT-2\Ant-2.emi (14) Date: 2005-03-07

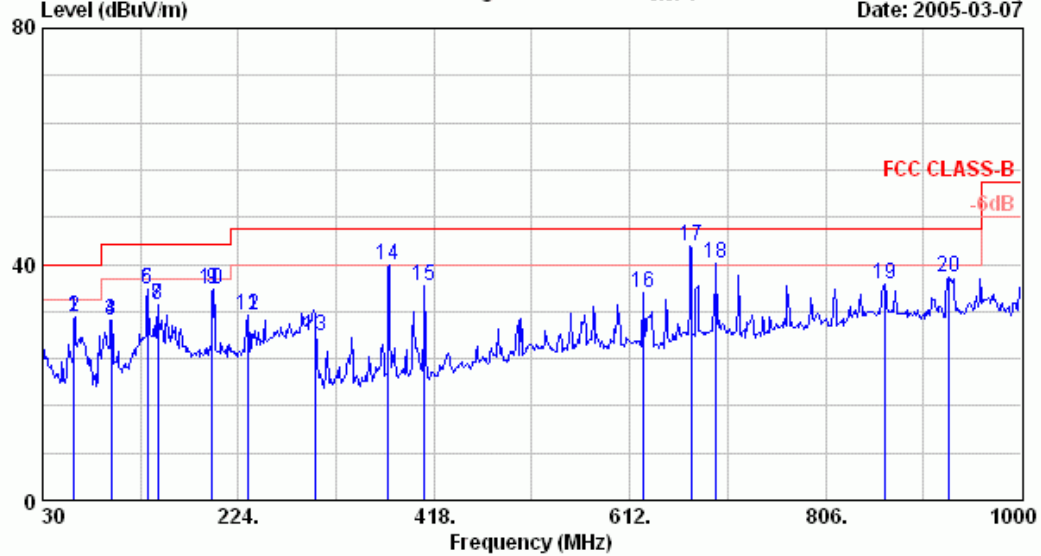

Site : A/C Chamber Date : 12
 Condition : 3m BBA9106/UHALP9108-A Polarity: HORIZONTAL
 Limit : FCC CLASS-B
 Env. / Ins. : 8593EM 18*C/62% Engineer: henning
 EUT : RF-Modem using digital modulation
 Power Rating : DC 3.9V M/N:FRH-SD07TU
 Test Mode : TX (2420MHz)---ANT2

	Ant.	Cable	Emission				
Freq. (MHz)	Factor (dB/m)	Loss (dB)	Reading (dBuV)	Level (dBuV/m)	Limits (dBuV/m)	Margin (dB)	Remark
1	61.590	12.28	1.60	17.22	31.11	40.00	8.89
2	61.590	12.28	1.60	17.22	31.11	40.00	8.89
3	98.040	16.84	2.10	11.51	30.45	43.50	13.05
4	98.040	16.84	2.10	11.51	30.45	43.50	13.05
5	133.680	19.89	2.40	13.40	35.69	43.50	7.81
6	133.680	19.89	2.40	13.40	35.69	43.50	7.81
7	144.480	20.31	2.60	10.08	33.00	43.50	10.50
8	144.480	20.31	2.60	10.08	33.00	43.50	10.50
9	198.480	22.07	3.00	10.81	35.88	43.50	7.62
10	198.480	22.07	3.00	10.81	35.88	43.50	7.62
11	233.040	22.36	3.30	5.81	31.48	46.00	14.52
12	233.040	22.36	3.30	5.81	31.48	46.00	14.52
13	300.700	14.52	3.90	9.50	27.92	46.00	18.08
14	372.800	17.12	4.60	18.17	39.90	46.00	6.10
15	407.800	17.31	4.90	14.22	36.42	46.00	9.58
16	624.800	21.31	6.20	7.72	35.23	46.00	10.77
17	672.400	22.85	6.40	13.76	43.02	46.00	2.98
18	696.900	23.32	6.50	10.44	40.26	46.00	5.74
19	864.900	26.00	7.20	3.42	36.62	46.00	9.38
20	927.900	24.80	7.50	5.45	37.75	46.00	8.25

Remarks: 1. Emission Level= Antenna Factor + Cable Loss + Reading.
 2. The emission levels that are 20dB below the official limit are not reported.



EMC Laboratory
 No.53-11, Tin-fu Tsun, Lin-kou Hsiang, Taipei
 County, Taiwan R.O.C. Post Code:24443
 Tel:+886-2-26092133 Fax:+886-2-26099303
 Email:ttenc@ttenc.com.tw

Data: 11 File: C:\Documents and Settings\Administrator\桌面\FUTUBA\ANT-2\ANT-2\Ant-2.emi (14)
 Level (dBuV/m) Date: 2005-03-07

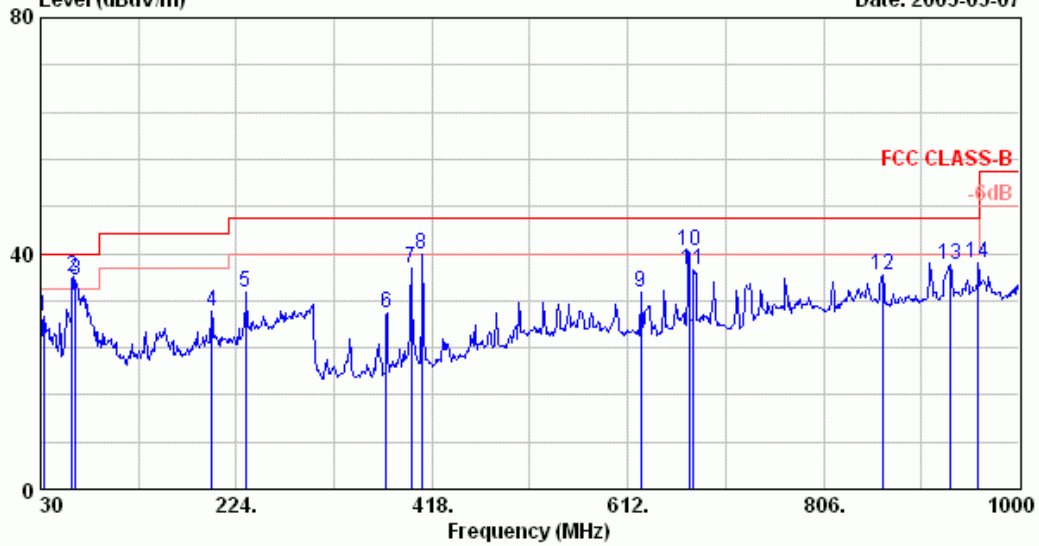

Site : A/C Chamber Date : 11
 Condition : 3m BBA9106/UHALP9108-A Polarity: VERTICAL
 Limit : FCC CLASS-B
 Env. / Ins. : 8593EM 18*C/62% Engineer: henning
 EUT : RF-Modem using digital modulation
 Power Rating : DC 3.9V M/N:FRH-SD07TU
 Test Mode : TX (2420MHz)---ANT2

	Ant. Factor	Cable Loss	Emission		Limits	Margin	Remark
Freq. (MHz)	(dB/m)	(dB)	Reading (dBuV)	Level (dBuV/m)	(dBuV/m)	(dB)	
1	33.240	22.11	1.10	6.03	29.24	40.00	10.76
2	61.590	13.37	1.60	21.11	36.07	40.00	3.93
3	64.560	12.84	1.70	20.80	35.35	40.00	4.65
4	199.830	22.86	3.00	4.28	30.14	43.50	13.36
5	233.040	24.76	3.30	5.30	33.36	46.00	12.64
6	372.800	15.78	4.60	9.44	29.82	46.00	16.18
7	397.300	17.67	4.80	14.90	37.37	46.00	8.63
8	407.800	17.19	4.90	17.68	39.77	46.00	6.23
9	624.800	21.15	6.20	6.01	33.36	46.00	12.64
10	672.400	23.07	6.40	10.93	40.41	46.00	5.59
11	677.300	23.38	6.40	7.38	37.17	46.00	8.83
12	864.900	25.38	7.20	3.72	36.29	46.00	9.71
13	931.400	26.17	7.50	4.51	38.18	46.00	7.82
14	959.400	27.16	7.60	3.51	38.27	46.00	7.73

Remarks: 1. Emission Level= Antenna Factor + Cable Loss + Reading.
 2. The emission levels that are 20dB below the official limit are not reported.



EMC Laboratory
 No.53-11, Tin-fu Tsun, Lin-kou Hsiang, Taipei
 County, Taiwan R.O.C. Post Code:24443
 Tel:+886-2-26092133 Fax:+886-2-26099303
 Email:ttenc@ttenc.com.tw

Data: 12 File: C:\Documents and Settings\Administrator\桌面\FUTUBA\ANT-2\ANT-2(M)\Ant-2(M).er
 Level (dBuV/m) Date: 2005-03-07

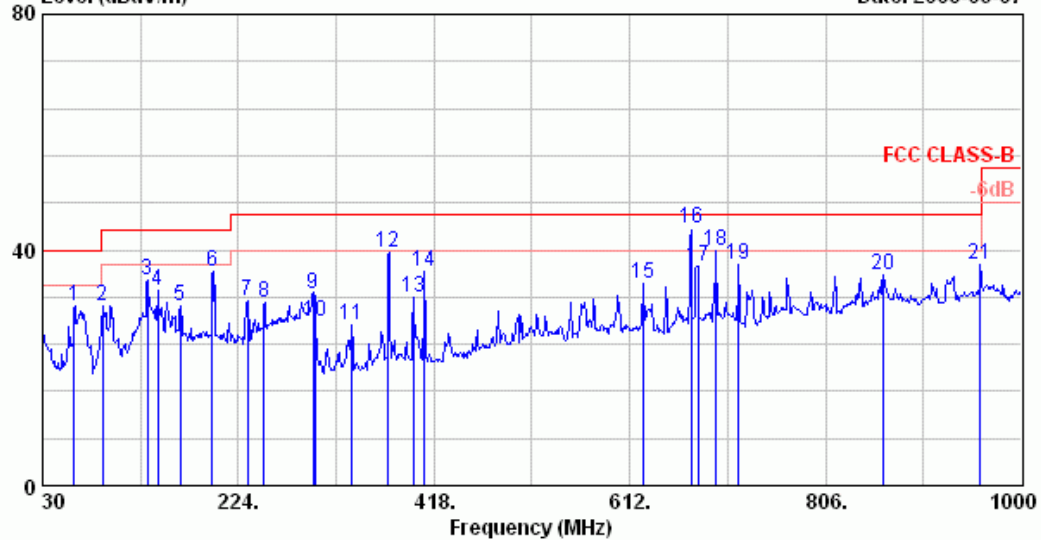

Site : A/C Chamber Date : 12
 Condition : 3m BBA9106/UHALP9108-A Polarity: HORIZONTAL
 Limit : FCC CLASS-B
 Env. / Ins. : 8593EM 18*C/62% Engineer: henning
 EUT : RF-Modem using digital modulation
 Power Rating : DC 3.9V M/N:FRH-SD07TU
 Test Mode : TX (2450MHz)---ANT2

Ant.	Cable	Emission					
Freq.	Factor	Loss	Reading	Level	Limits	Margin	Remark
(MHz)	(dB/m)	(dB)	(dBuV)	(dBuV/m)	(dBuV/m)	(dB)	
1	61.590	12.28	1.60	16.67	30.56	40.00	9.44
2	89.130	15.57	2.00	12.92	30.50	43.50	13.00
3	133.680	19.89	2.40	12.68	34.97	43.50	8.53
4	144.480	20.31	2.60	10.28	33.20	43.50	10.30
5	166.080	20.93	2.70	6.71	30.34	43.50	13.16
6	198.480	22.07	3.00	11.35	36.42	43.50	7.08
7	233.040	22.36	3.30	5.79	31.46	46.00	14.54
8	249.780	23.83	3.50	3.85	31.18	46.00	14.82
9	298.110	26.68	3.98	1.97	32.63	46.00	13.37
10	300.000	26.77	3.90	-2.81	27.86	46.00	18.14
11	336.400	15.08	4.20	8.03	27.32	46.00	18.68
12	372.800	17.12	4.60	17.72	39.45	46.00	6.55
13	397.300	17.64	4.80	9.55	31.99	46.00	14.01
14	407.800	17.31	4.90	14.07	36.27	46.00	9.73
15	624.800	21.31	6.20	6.72	34.23	46.00	11.77
16	672.400	22.85	6.40	14.35	43.61	46.00	2.39
17	679.400	22.92	6.40	7.94	37.26	46.00	8.74
18	696.900	23.32	6.50	10.10	39.92	46.00	6.08
19	719.300	22.30	6.60	8.68	37.58	46.00	8.42
20	862.800	26.09	7.20	2.47	35.76	46.00	10.24
21	959.400	26.38	7.60	3.39	37.38	46.00	8.62

Remarks: 1. Emission Level= Antenna Factor + Cable Loss + Reading.
 2. The emission levels that are 20dB below the official limit are not reported.



EMC Laboratory
 No.53-11, Tin-fu Tsun, Lin-kou Hsiang, Taipei
 County, Taiwan R.O.C. Post Code:24443
 Tel:+886-2-26092133 Fax:+886-2-26099303
 Email:ttemc@ttemc.com.tw

Data: 11 File: C:\Documents and Settings\Administrator\桌面\FUTUBA\ANT-2\ANT-2(M)\Ant-2(M).er Date: 2005-03-07

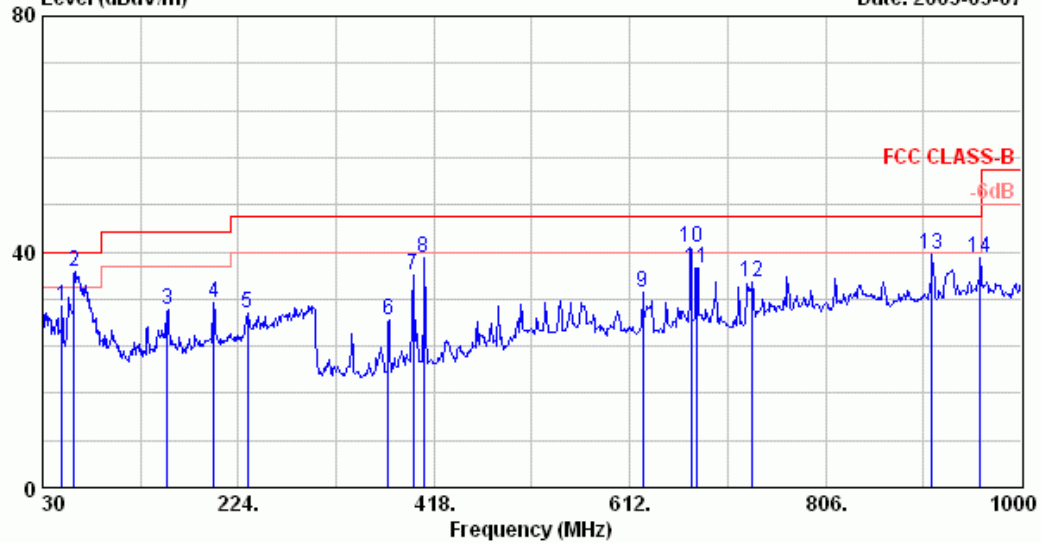

Site : A/C Chamber Date : 11
 Condition : 3m BBA9106/UHALP9108-A Polarity: VERTICAL
 Limit : FCC CLASS-B
 Env. / Ins. : 8593EM 18*C/62% Engineer: henning
 EUT : RF-Modem using digital modulation
 Power Rating : DC 3.9V M/N:FRH-SD07TU
 Test Mode : TX (2450MHz)---ANT2

	Ant. Cable			Emission			
Freq. (MHz)	Factor (dB/m)	Loss (dB)	Reading (dBuV)	Level (dBuV/m)	Limits (dBuV/m)	Margin (dB)	Remark
1	16.26	1.50	13.12	30.88	40.00	9.12	
2	13.37	1.60	21.69	36.65	40.00	3.35	
3	21.17	2.60	6.53	30.30	43.50	13.20	
4	22.86	3.00	5.59	31.45	43.50	12.05	
5	24.76	3.30	1.45	29.51	46.00	16.49	
6	15.78	4.60	8.03	28.41	46.00	17.59	
7	17.67	4.80	13.56	36.03	46.00	9.97	
8	17.19	4.90	17.01	39.10	46.00	6.90	
9	21.15	6.20	5.65	33.00	46.00	13.00	
10	23.07	6.40	11.30	40.78	46.00	5.22	
11	23.43	6.40	7.44	37.27	46.00	8.73	
12	22.98	6.70	5.32	35.00	46.00	11.00	
13	25.69	7.40	6.61	39.70	46.00	6.30	
14	27.16	7.60	4.20	38.96	46.00	7.04	

Remarks: 1. Emission Level= Antenna Factor + Cable Loss + Reading.
 2. The emission levels that are 20dB below the official limit are not reported.



EMC Laboratory
 No.53-11, Tin-fu Tsun, Lin-kou Hsiang, Taipei
 County, Taiwan R.O.C. Post Code:24443
 Tel:+886-2-26092133 Fax:+886-2-26099303
 Email:ttenc@ttenc.com.tw

Data: 11 File: C:\Documents and Settings\Administrator\桌面\ANT-H\ANT-2(H)\ANT-2EE\Ant-2(H).er Date: 2005-04-13

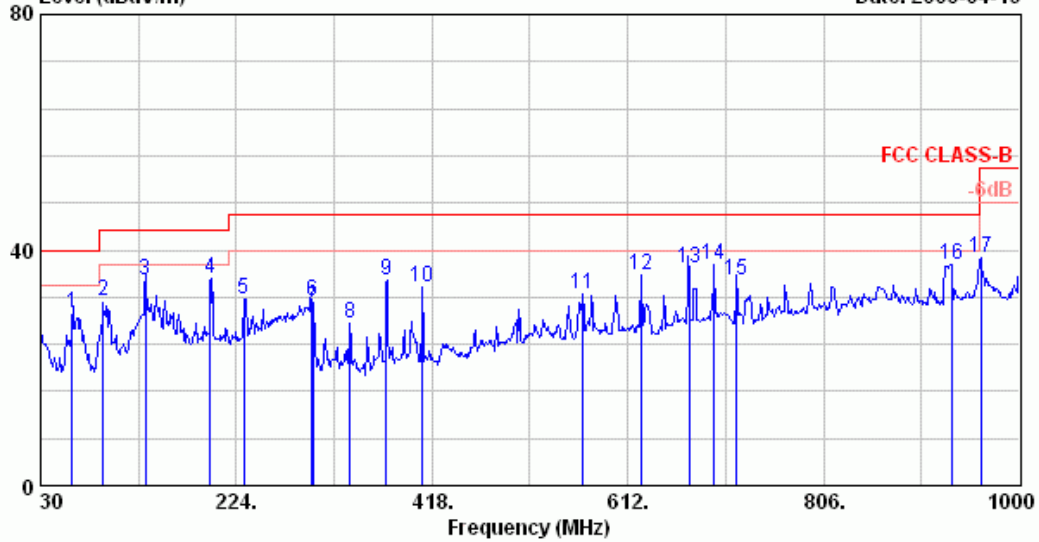

Site : A/C Chamber Date : 11
 Condition : 3m BBA9106/UHALP9108-A Polarity: HORIZONTAL
 Limit : FCC CLASS-B
 Env. / Ins. : 8593EM 21*C/59% Engineer: henning
 EUT : RF-Modem using digital modulation
 Power Rating : DC 3.9V M/N:FRH-SD07TU
 Test Mode : TX (2473MHz)---ANT2

	Freq. (MHz)	Ant. Factor (dB/m)	Cable Loss (dB)	Reading (dBuV)	Emission Level (dBuV/m)	Limits (dBuV/m)	Margin (dB)	Remark
1	61.590	12.28	1.60	15.56	29.45	40.00	10.55	
2	91.830	16.08	2.00	13.31	31.38	43.50	12.12	
3	133.680	19.89	2.40	12.50	34.79	43.50	8.71	
4	198.480	22.07	3.00	10.04	35.11	43.50	8.39	
5	231.690	22.25	3.30	6.19	31.73	46.00	14.27	
6	298.650	26.72	3.90	0.70	31.32	46.00	14.68	
7	300.000	26.77	3.90	-0.59	30.08	46.00	15.92	
8	336.400	15.08	4.20	8.38	27.67	46.00	18.33	
9	372.800	17.12	4.60	13.24	34.97	46.00	11.03	
10	407.800	17.31	4.90	11.35	33.55	46.00	12.45	
11	567.400	20.97	6.50	5.00	32.48	46.00	13.52	
12	624.800	21.31	6.20	8.34	35.85	46.00	10.15	
13	672.400	22.85	6.40	7.74	37.00	46.00	9.00	
14	696.900	23.32	6.50	7.62	37.44	46.00	8.56	
15	719.300	22.30	6.60	5.91	34.81	46.00	11.19	
16	932.800	25.23	7.50	4.84	37.57	46.00	8.43	
17	962.170	26.54	7.60	4.40	38.54	54.00	15.46	

Remarks: 1. Emission Level= Antenna Factor + Cable Loss + Reading.
 2. The emission levels that are 20dB below the official limit are not reported.



EMC Laboratory
 No.53-11, Tin-fu Tsun, Lin-kou Hsiang, Taipei
 County, Taiwan R.O.C. Post Code:24443
 Tel:+886-2-26092133 Fax:+886-2-26099303
 Email:ttenc@ttenc.com.tw

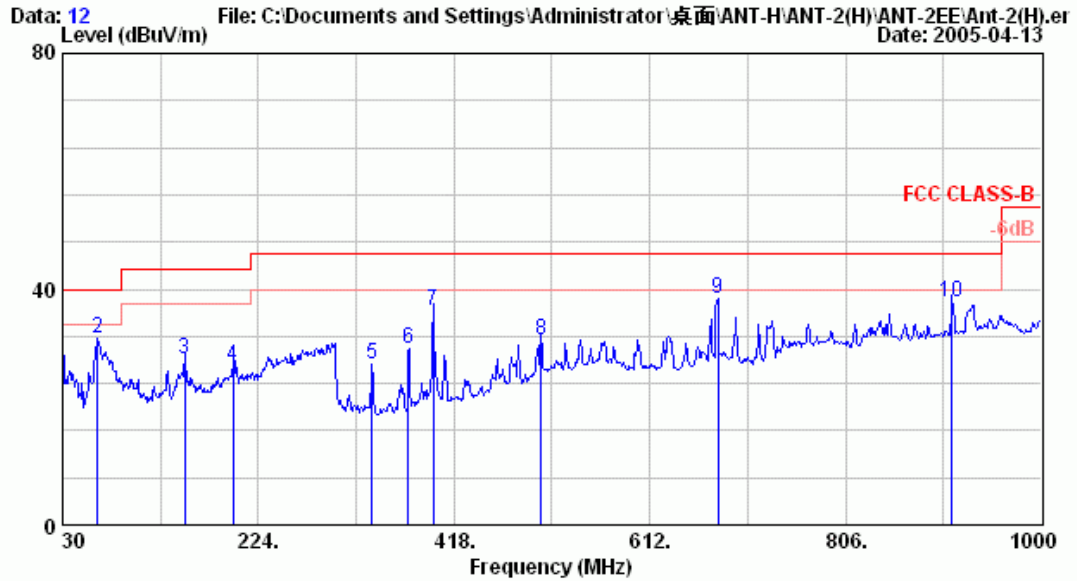

Site : A/C Chamber Date : 12
 Condition : 3m BBA9106/UHALP9108-A Polarity: VERTICAL
 Limit : FCC CLASS-B
 Env. / Ins. : 8593EM 21*C/59% Engineer: henning
 EUT : RF-Modem using digital modulation
 Power Rating : DC 3.9V M/N:FRH-SD07TU
 Test Mode : TX (2473MHz)---ANT2

	Ant.	Cable	Emission					
Freq.	Factor	Loss	Reading	Level	Limits	Margin	Remark	
(MHz)	(dB/m)	(dB)	(dBuV)	(dBuV/m)	(dBuV/m)	(dB)		
1	30.540	23.39	1.10	3.14	27.63	40.00	12.37	
2	64.560	12.84	1.70	17.08	31.63	40.00	8.37	
3	151.230	21.87	2.60	3.80	28.26	43.50	15.24	
4	199.290	22.86	3.00	0.96	26.82	43.50	16.68	
5	336.400	15.54	4.20	7.65	27.39	46.00	18.61	
6	372.800	15.78	4.60	9.65	30.03	46.00	15.97	
7	397.300	17.67	4.80	13.95	36.42	46.00	9.58	
8	504.400	20.21	6.62	4.65	31.47	46.00	14.53	
9	679.400	23.47	6.40	8.38	38.25	46.00	7.75	
10	911.800	25.69	7.40	4.83	37.92	46.00	8.08	

Remarks: 1. Emission Level= Antenna Factor + Cable Loss + Reading.
 2. The emission levels that are 20dB below the official limit are not reported.



EMC Laboratory
 No.53-11, Tin-fu Tsun, Lin-kou Hsiang, Taipei
 County, Taiwan R.O.C. Post Code:24443
 Tel:+886-2-26092133 Fax:+886-2-26099303
 Email:ttenc@ttenc.com.tw

Data: 12 File: C:\Documents and Settings\Administrator\桌面\FUTUBA\ANT-2\ANT-2RX\Ant-2-rxS.e Date: 2005-03-07

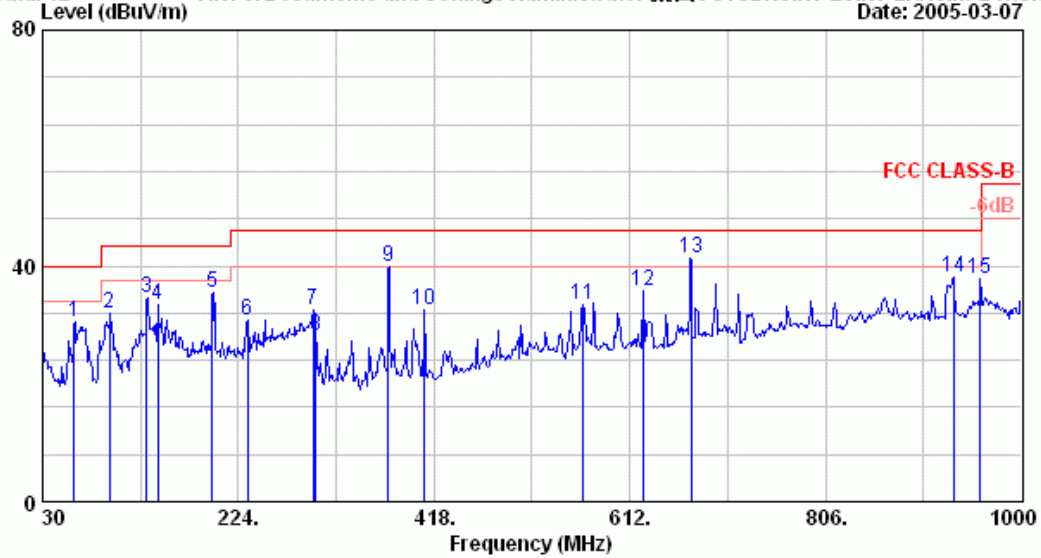

Site : A/C Chamber Date : 12
 Condition : 3m BBA9106/UHALP9108-A Polarity: HORIZONTAL
 Limit : FCC CLASS-B
 Env. / Ins. : 8593EM 18°C/62% Engineer: henning
 EUT : RF-Modem using digital modulation
 Power Rating : DC 3.9V M/N:FRH-SD07TU
 Test Mode : RX (2420MHz)---ANT2

	Ant.	Cable	Emission				
Freq. (MHz)	Factor (dB/m)	Loss (dB)	Reading (dBuV)	Level (dBuV/m)	Limits (dBuV/m)	Margin (dB)	Remark
1	61.590	12.28	1.60	16.51	30.40	40.00	9.60
2	96.690	16.75	2.05	13.14	31.94	43.50	11.56
3	133.410	19.89	2.40	12.20	34.49	43.50	9.01
4	144.480	20.31	2.60	10.35	33.27	43.50	10.23
5	198.480	22.07	3.00	10.46	35.53	43.50	7.97
6	233.040	22.36	3.30	5.14	30.81	46.00	15.19
7	298.380	26.72	3.90	2.01	32.63	46.00	13.37
8	300.700	14.52	3.90	9.65	28.07	46.00	17.93
9	372.800	17.12	4.60	18.02	39.75	46.00	6.25
10	407.800	17.31	4.90	10.30	32.50	46.00	13.50
11	565.300	20.49	6.60	6.29	33.38	46.00	12.62
12	624.800	21.31	6.20	8.21	35.72	46.00	10.28
13	672.400	22.85	6.40	12.01	41.27	46.00	4.73
14	932.800	25.23	7.50	5.33	38.06	46.00	7.94
15	959.400	26.38	7.60	3.81	37.80	46.00	8.20

Remarks: 1. Emission Level= Antenna Factor + Cable Loss + Reading.
 2. The emission levels that are 20dB below the official limit are not reported.



EMC Laboratory
 No.53-11, Tin-fu Tsun, Lin-kou Hsiang, Taipei
 County, Taiwan R.O.C. Post Code:24443
 Tel:+886-2-26092133 Fax:+886-2-26099303
 Email:ttemc@ttemc.com.tw

Data: 11 File: C:\Documents and Settings\Administrator\桌面\FUTUBA\ANT-2\ANT-2RX\Ant-2-rxS.e Date: 2005-03-07

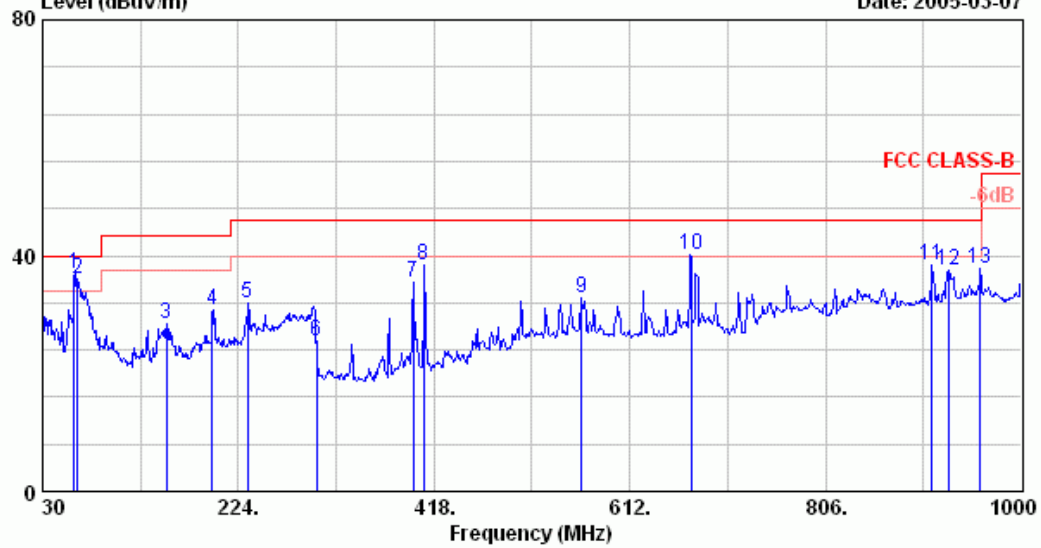

Site : A/C Chamber Date : 11
 Condition : 3m BBA9106/UHALP9108-A Polarity: VERTICAL
 Limit : FCC CLASS-B
 Env. / Ins. : 8593EM 18*C/62% Engineer: henning
 EUT : RF-Modem using digital modulation
 Power Rating : DC 3.9V M/N:FRH-SD07TU
 Test Mode : RX (2420MHz)---ANT2

	Ant.	Cable	Emission					
Freq.	Factor	Loss	Reading	Level	Limits	Margin	Remark	
(MHz)	(dB/m)	(dB)	(dBuV)	(dBuV/m)	(dBuV/m)	(dB)		
1	61.590	13.37	1.60	22.00	36.96	40.00	3.04	
2	64.290	13.06	1.67	21.41	36.13	40.00	3.87	
3	152.580	21.70	2.60	4.14	28.44	43.50	15.06	
4	198.480	22.74	3.00	4.91	30.65	43.50	12.85	
5	233.040	24.76	3.30	4.02	32.08	46.00	13.92	
6	301.400	14.83	3.90	6.85	25.59	46.00	20.41	
7	397.300	17.67	4.80	13.00	35.47	46.00	10.53	
8	407.800	17.19	4.90	16.19	38.28	46.00	7.72	
9	563.900	22.08	6.61	4.24	32.94	46.00	13.07	
10	672.400	23.07	6.40	10.81	40.29	46.00	5.71	
11	911.800	25.69	7.40	5.17	38.26	46.00	7.74	
12	927.900	25.91	7.50	4.21	37.62	46.00	8.38	
13	959.400	27.16	7.60	3.15	37.91	46.00	8.09	

Remarks: 1. Emission Level= Antenna Factor + Cable Loss + Reading.
 2. The emission levels that are 20dB below the official limit are not reported.



EMC Laboratory
 No.53-11, Tin-fu Tsun, Lin-kou Hsiang, Taipei
 County, Taiwan R.O.C. Post Code:24443
 Tel:+886-2-26092133 Fax:+886-2-26099303
 Email:ttenc@ttenc.com.tw

Data: 14 File: C:\Documents and Settings\Administrator\桌面\FUTUBA\ANT-3\ANT-3\Ant-3.emi (14) Date: 2005-03-07

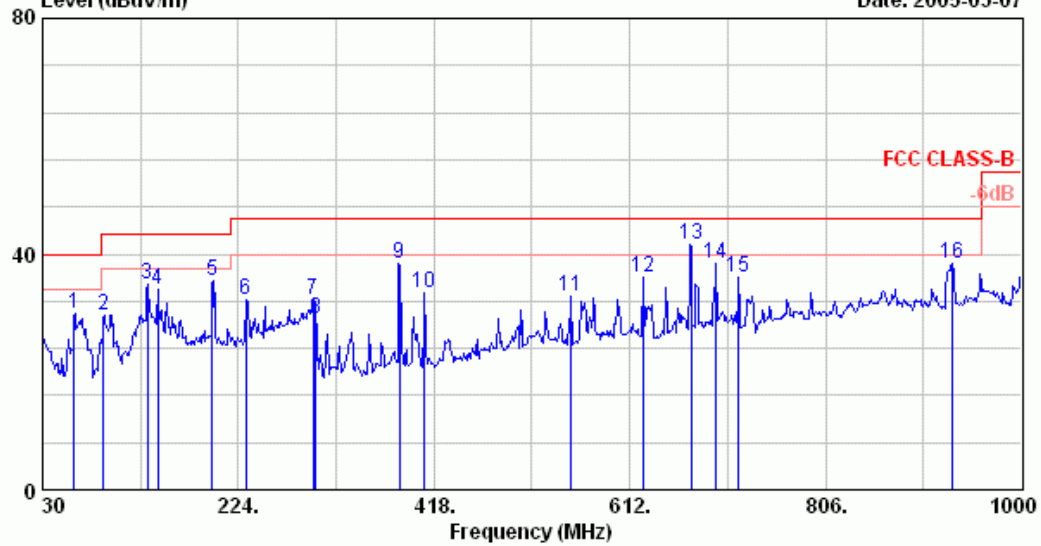

Site : A/C Chamber Date : 14
 Condition : 3m BBA9106/UHALP9108-A Polarity: HORIZONTAL
 Limit : FCC CLASS-B
 Env. / Ins. : 8593EM 18°C/62% Engineer: henning
 EUT : RF-Modem using digital modulation
 Power Rating : DC 3.9V M/N:FRH-SD07TU
 Test Mode : TX (2420MHz)---ANT3

Ant.	Cable	Emission					
Freq.	Factor	Loss	Reading	Level	Limits	Margin	Remark
(MHz)	(dB/m)	(dB)	(dBuV)	(dBuV/m)	(dBuV/m)	(dB)	
1	61.590	12.28	1.60	16.14	30.03	40.00	9.97
2	90.480	15.77	2.00	11.69	29.46	43.50	14.04
3	133.680	19.89	2.40	12.72	35.01	43.50	8.49
4	144.480	20.31	2.60	10.96	33.88	43.50	9.62
5	198.480	22.07	3.00	10.28	35.35	43.50	8.15
6	231.690	22.25	3.30	6.59	32.13	46.00	13.87
7	298.380	26.72	3.90	1.55	32.17	46.00	13.83
8	300.700	14.52	3.90	10.63	29.05	46.00	16.95
9	383.300	17.33	4.62	16.56	38.52	46.00	7.48
10	407.800	17.31	4.90	11.12	33.32	46.00	12.68
11	553.400	19.40	6.80	6.50	32.70	46.00	13.30
12	624.800	21.31	6.20	8.44	35.95	46.00	10.05
13	672.400	22.85	6.40	12.21	41.47	46.00	4.53
14	696.900	23.32	6.50	8.54	38.36	46.00	7.64
15	719.300	22.30	6.60	7.15	36.05	46.00	9.95
16	931.400	25.11	7.50	5.78	38.39	46.00	7.61

Remarks: 1. Emission Level= Antenna Factor + Cable Loss + Reading.
 2. The emission levels that are 20dB below the official limit are not reported.



EMC Laboratory
 No.53-11, Tin-fu Tsun, Lin-kou Hsiang, Taipei
 County, Taiwan R.O.C. Post Code:24443
 Tel:+886-2-26092133 Fax:+886-2-26099303
 Email:ttenc@ttenc.com.tw

Data: 13 File: C:\Documents and Settings\Administrator\桌面\FUTUBA\ANT-3\ANT-3\Ant-3.emi (14) Date: 2005-03-07

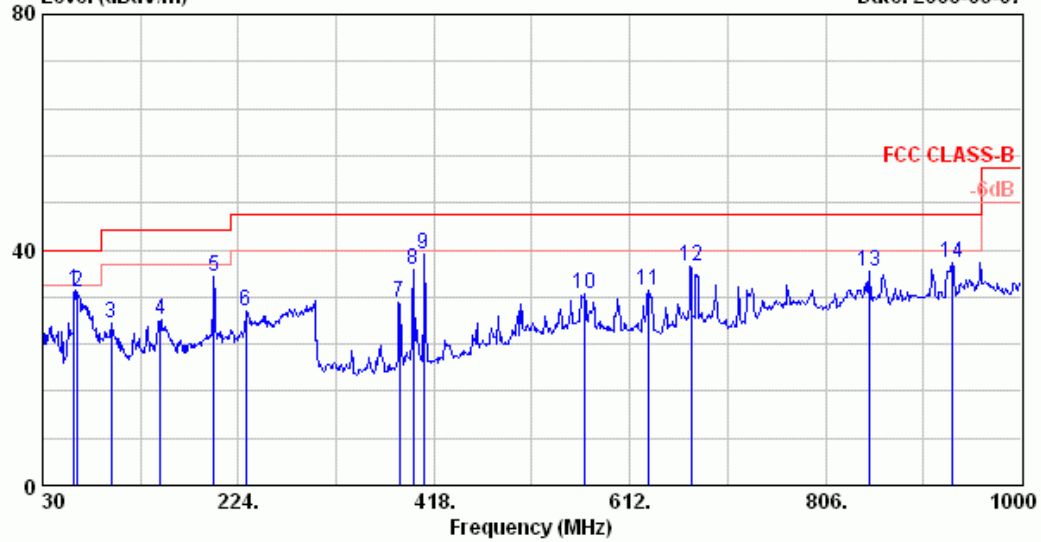

Site : A/C Chamber Date : 13
 Condition : 3m BBA9106/UHALP9108-A Polarity: VERTICAL
 Limit : FCC CLASS-B
 Env. / Ins. : 8593EM 18°C/62% Engineer: henning
 EUT : RF-Modem using digital modulation
 Power Rating : DC 3.9V M/N:FRH-SD07TU
 Test Mode : TX (2420MHz)---ANT3

Freq. (MHz)	Ant. Factor (dB/m)	Cable Loss (dB)	Reading (dBuV)	Emission Level (dBuV/m)	Limits (dBuV/m)	Margin (dB)	Remark
1	13.37	1.60	18.12	33.08	40.00	6.92	
2	13.06	1.67	18.07	32.79	40.00	7.21	
3	17.54	2.10	7.97	27.61	43.50	15.89	
4	21.57	2.50	4.13	28.19	43.50	15.31	
5	22.86	3.00	9.70	35.56	43.50	7.94	
6	24.33	3.30	2.03	29.66	46.00	16.34	
7	17.08	4.62	9.46	31.16	46.00	14.84	
8	17.67	4.80	14.11	36.58	46.00	9.42	
9	17.19	4.90	17.03	39.12	46.00	6.88	
10	22.08	6.50	4.03	32.61	46.00	13.39	
11	21.09	6.40	5.72	33.21	46.00	12.79	
12	23.07	6.40	7.83	37.31	46.00	8.69	
13	26.54	7.10	2.58	36.22	46.00	9.78	
14	26.17	7.50	4.22	37.89	46.00	8.11	

Remarks: 1. Emission Level= Antenna Factor + Cable Loss + Reading.
 2. The emission levels that are 20dB below the official limit are not reported.



EMC Laboratory
 No.53-11, Tin-fu Tsun, Lin-kou Hsiang, Taipei
 County, Taiwan R.O.C. Post Code:24443
 Tel:+886-2-26092133 Fax:+886-2-26099303
 Email:ttenc@ttenc.com.tw

Data: 14 File: C:\Documents and Settings\Administrator\桌面\FUTUBA\ANT-3\ANT-3(M)\Ant-3(M).er Date: 2005-03-07

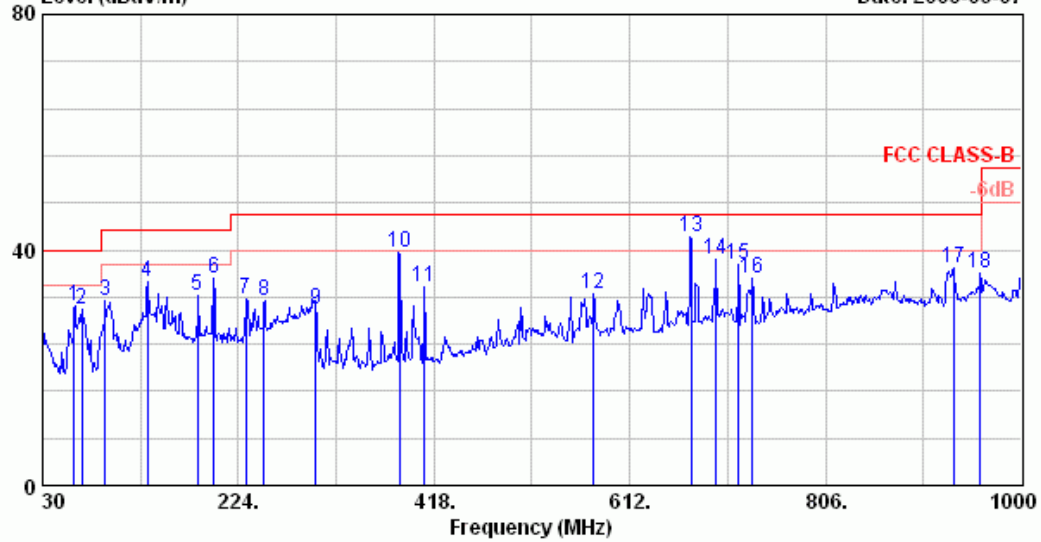

Site : A/C Chamber Date : 14
 Condition : 3m BBA9106/UHALP9108-A Polarity: HORIZONTAL
 Limit : FCC CLASS-B
 Env. / Ins. : 8593EM 18*C/62% Engineer: henning
 EUT : RF-Modem using digital modulation
 Power Rating : DC 3.9V M/N:FRH-SD07TU
 Test Mode : TX (2450MHz)---ANT3

	Freq. (MHz)	Ant. Factor (dB/m)	Cable Loss (dB)	Reading (dBuV)	Emission Level (dBuV/m)	Limits (dBuV/m)	Margin (dB)	Remark
1	61.590	12.28	1.60	16.72	30.61	40.00	9.39	
2	68.880	11.93	1.70	16.14	29.77	40.00	10.23	
3	91.830	16.08	2.00	13.20	31.27	43.50	12.23	
4	133.680	19.89	2.40	12.36	34.65	43.50	8.85	
5	183.630	21.34	2.90	7.88	32.12	43.50	11.38	
6	199.830	22.09	3.00	10.19	35.28	43.50	8.22	
7	231.690	22.25	3.30	5.96	31.50	46.00	14.50	
8	249.780	23.83	3.50	3.88	31.21	46.00	14.79	
9	300.700	14.52	3.90	11.57	29.98	46.00	16.02	
10	383.300	17.33	4.62	17.63	39.59	46.00	6.41	
11	407.800	17.31	4.90	11.54	33.74	46.00	12.26	
12	575.800	21.05	6.40	5.03	32.48	46.00	13.52	
13	672.400	22.85	6.40	13.00	42.26	46.00	3.74	
14	696.900	23.32	6.50	8.43	38.25	46.00	7.75	
15	719.300	22.30	6.60	8.47	37.37	46.00	8.63	
16	733.300	22.09	6.70	6.24	35.03	46.00	10.97	
17	932.800	25.23	7.50	4.28	37.01	46.00	8.99	
18	959.400	26.38	7.60	2.11	36.10	46.00	9.90	

Remarks: 1. Emission Level= Antenna Factor + Cable Loss + Reading.
 2. The emission levels that are 20dB below the official limit are not reported.



EMC Laboratory
 No.53-11, Tin-fu Tsun, Lin-kou Hsiang, Taipei
 County, Taiwan R.O.C. Post Code:24443
 Tel:+886-2-26092133 Fax:+886-2-26099303
 Email:ttenc@ttenc.com.tw

Data: 13 File: C:\Documents and Settings\Administrator\桌面\FUTUBA\ANT-3\ANT-3(M)\Ant-3(M).er Date: 2005-03-07

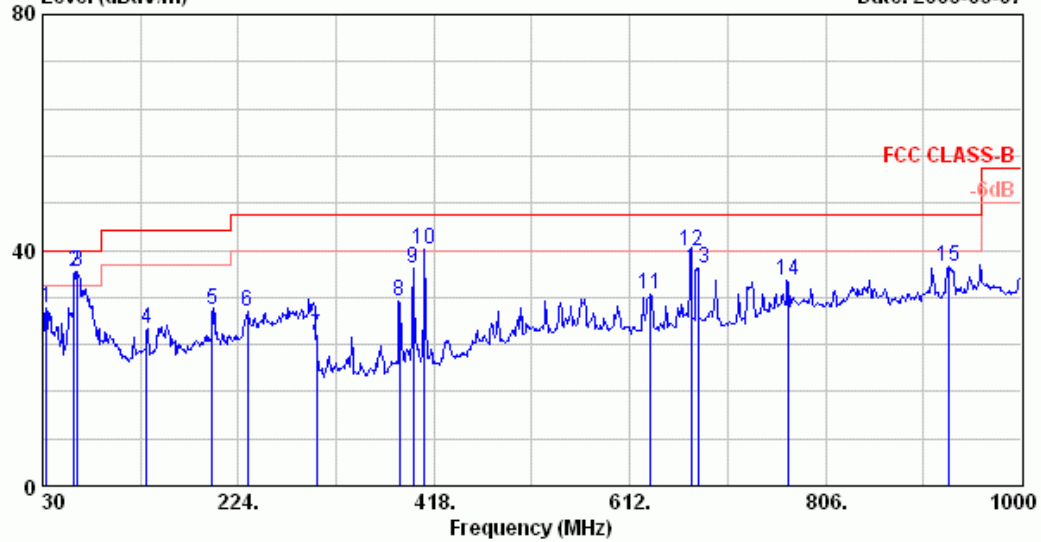

Site : A/C Chamber Date : 13
 Condition : 3m BBA9106/UHALP9108-A Polarity: VERTICAL
 Limit : FCC CLASS-B
 Env. / Ins. : 8593EM 18°C/62% Engineer: henning
 EUT : RF-Modem using digital modulation
 Power Rating : DC 3.9V M/N:FRH-SD07TU
 Test Mode : TX (2450MHz)---ANT3

	Freq. (MHz)	Ant. Factor (dB/m)	Cable Loss (dB)	Reading (dBuV)	Emission Level (dBuV/m)	Limits (dBuV/m)	Margin (dB)	Remark
1	33.780	21.97	1.10	7.01	30.08	40.00	9.92	
2	61.590	13.37	1.60	21.37	36.33	40.00	3.67	
3	64.560	12.84	1.70	21.87	36.41	40.00	3.59	
4	133.140	19.09	2.40	5.28	26.76	43.50	16.74	
5	198.480	22.74	3.00	4.23	29.97	43.50	13.53	
6	233.040	24.76	3.30	1.62	29.68	46.00	16.32	
7	301.400	14.83	3.90	6.85	25.59	46.00	20.41	
8	383.300	17.08	4.62	9.57	31.27	46.00	14.73	
9	397.300	17.67	4.80	14.51	36.98	46.00	9.02	
10	407.800	17.19	4.90	18.17	40.26	46.00	5.74	
11	631.800	21.09	6.40	5.10	32.59	46.00	13.41	
12	672.400	23.07	6.40	10.38	39.86	46.00	6.14	
13	679.400	23.47	6.40	7.05	36.92	46.00	9.08	
14	768.300	24.98	6.80	3.04	34.83	46.00	11.17	
15	927.900	25.91	7.50	3.66	37.07	46.00	8.93	

Remarks: 1. Emission Level= Antenna Factor + Cable Loss + Reading.
 2. The emission levels that are 20dB below the official limit are not reported.



EMC Laboratory
 No.53-11, Tin-fu Tsun, Lin-kou Hsiang, Taipei
 County, Taiwan R.O.C. Post Code:24443
 Tel:+886-2-26092133 Fax:+886-2-26099303
 Email:ttmc@ttmc.com.tw

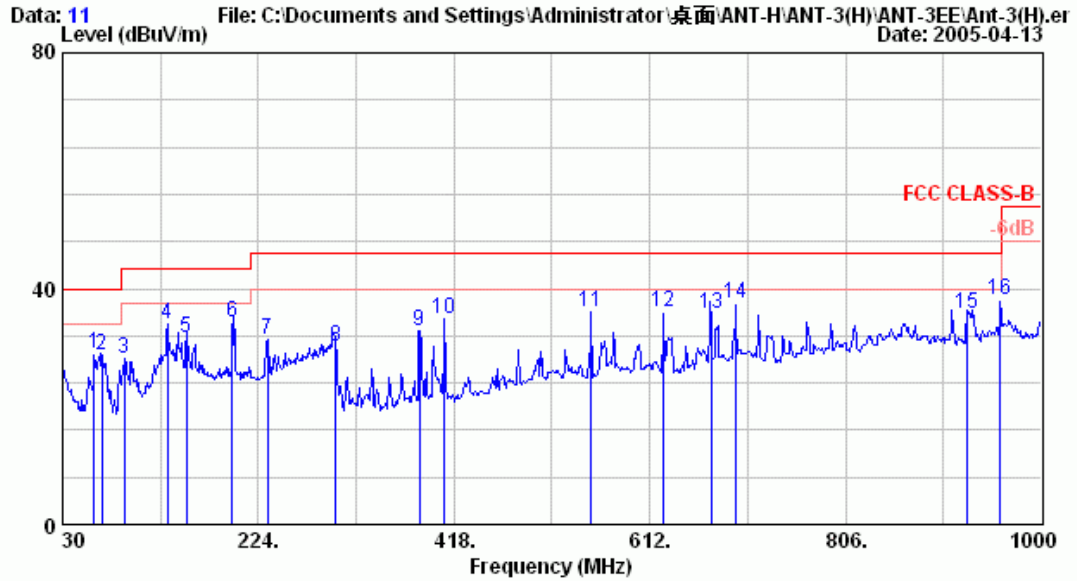

Site : A/C Chamber Date : 11
 Condition : 3m BBA9106/UHALP9108-A Polarity: HORIZONTAL
 Limit : FCC CLASS-B
 Env. / Ins. : 8593EM 21*C/59% Engineer: henning
 EUT : RF-Modem using digital modulation
 Power Rating : DC 3.9V M/N:FRH-SD07TU
 Test Mode : TX (2473MHz)---ANT3

	Ant.	Cable	Emission				
Freq. (MHz)	Factor (dB/m)	Loss (dB)	Reading (dBuV)	Level (dBuV/m)	Limits (dBuV/m)	Margin (dB)	Remark
1	61.590	12.28	1.60	15.00	28.89	40.00	11.11
2	68.880	11.93	1.70	15.07	28.70	40.00	11.30
3	91.290	15.90	2.00	10.31	28.21	43.50	15.29
4	133.680	19.89	2.40	11.57	33.86	43.50	9.64
5	152.580	20.68	2.60	8.43	31.71	43.50	11.79
6	198.480	22.07	3.00	9.16	34.23	43.50	9.27
7	233.040	22.36	3.30	5.79	31.46	46.00	14.54
8	300.700	14.52	3.90	11.83	30.25	46.00	15.75
9	383.300	17.33	4.62	10.84	32.80	46.00	13.20
10	407.800	17.31	4.90	12.79	34.99	46.00	11.01
11	553.800	19.40	6.80	9.84	36.04	46.00	9.96
12	624.800	21.31	6.20	8.51	36.02	46.00	9.98
13	672.400	22.85	6.40	6.48	35.74	46.00	10.26
14	696.900	23.32	6.50	7.59	37.41	46.00	8.59
15	925.800	24.67	7.43	3.78	35.88	46.00	10.12
16	959.400	26.38	7.60	4.11	38.10	46.00	7.90

Remarks: 1. Emission Level= Antenna Factor + Cable Loss + Reading.
 2. The emission levels that are 20dB below the official limit are not reported.



EMC Laboratory
 No.53-11, Tin-fu Tsun, Lin-kou Hsiang, Taipei
 County, Taiwan R.O.C. Post Code:24443
 Tel:+886-2-26092133 Fax:+886-2-26099303
 Email:ttenc@ttenc.com.tw

Data: 12 File: C:\Documents and Settings\Administrator\桌面\ANT-H\ANT-3(H)\ANT-3EE\Ant-3(H).er Date: 2005-04-13

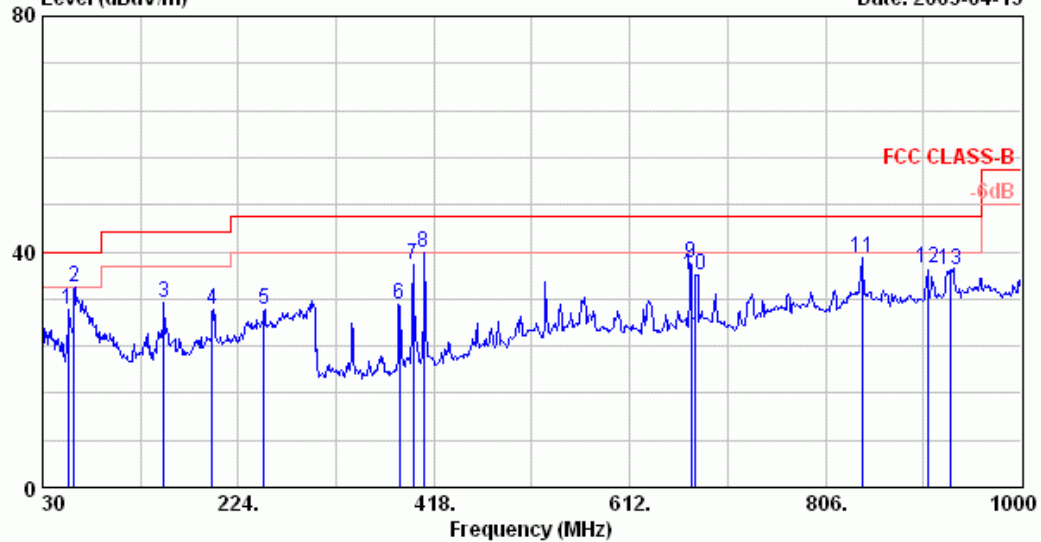

Site : A/C Chamber Date : 12
 Condition : 3m BBA9106/UHALP9108-A Polarity: VERTICAL
 Limit : FCC CLASS-B
 Env. / Ins. : 8593EM 21*C/59% Engineer: henning
 EUT : RF-Modem using digital modulation
 Power Rating : DC 3.9V M/N:FRH-SD07TU
 Test Mode : TX (2473MHz)---ANT3

	Ant.	Cable	Emission					
Freq. (MHz)	Factor (dB/m)	Loss (dB)	Reading (dBuV)	Level (dBuV/m)	Limits (dBuV/m)	Margin (dB)	Remark	
1	55.380	14.36	1.50	14.36	30.22	40.00	9.78	
2	61.590	13.37	1.60	18.96	33.92	40.00	6.08	
3	149.880	22.05	2.60	6.74	31.39	43.50	12.11	
4	198.480	22.74	3.00	4.54	30.28	43.50	13.22	
5	249.780	25.02	3.50	1.52	30.04	46.00	15.96	
6	383.300	17.08	4.62	9.29	30.99	46.00	15.01	
7	397.300	17.67	4.80	15.20	37.67	46.00	8.33	
8	407.800	17.19	4.90	17.77	39.86	46.00	6.14	
9	672.400	23.07	6.40	8.76	38.24	46.00	7.76	
10	677.300	23.38	6.40	6.33	36.12	46.00	9.88	
11	841.890	26.62	7.10	5.13	38.85	46.00	7.15	
12	906.900	25.75	7.40	4.02	37.17	46.00	8.83	
13	930.000	26.07	7.50	3.31	36.88	46.00	9.12	

Remarks: 1. Emission Level= Antenna Factor + Cable Loss + Reading.
 2. The emission levels that are 20dB below the official limit are not reported.



EMC Laboratory
 No.53-11, Tin-fu Tsun, Lin-kou Hsiang, Taipei
 County, Taiwan R.O.C. Post Code:24443
 Tel:+886-2-26092133 Fax:+886-2-26099303
 Email:ttenc@ttenc.com.tw

Data: 11 File: C:\Documents and Settings\Administrator\桌面\FUTUBA\ANT-3\ANT-3(RX)\Ant-3-rx.e Date: 2005-03-07

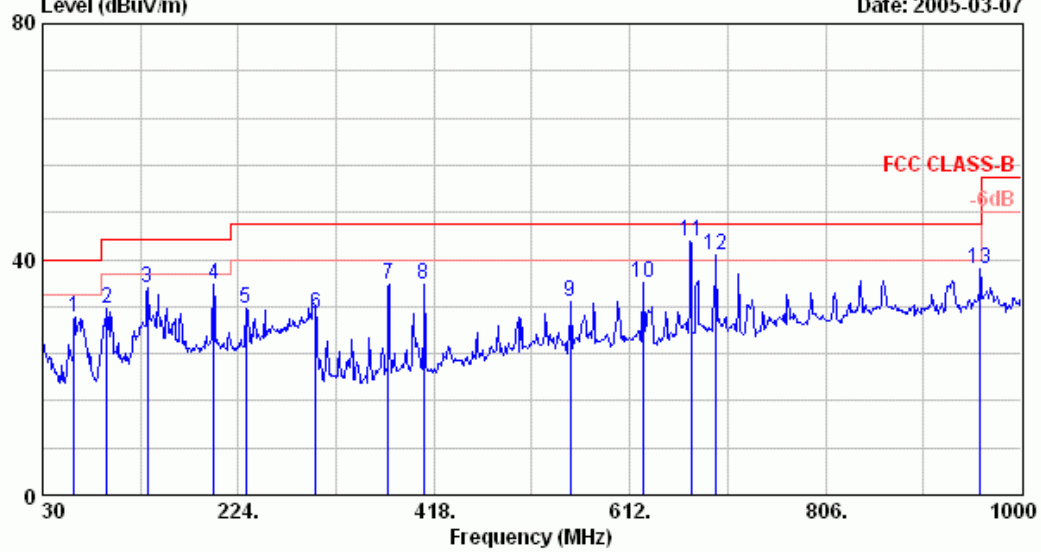

Site : A/C Chamber Date : 11
 Condition : 3m BBA9106/UHALP9108-A Polarity: HORIZONTAL
 Limit : FCC CLASS-B
 Env. / Ins. : 8593EM 18*C/62% Engineer: henning
 EUT : RF-Modem using digital modulation
 Power Rating : DC 3.9V M/N:FRH-SD07TU
 Test Mode : RX (2420MHz)---ANT3

	Ant.	Cable	Emission				
Freq. (MHz)	Factor (dB/m)	Loss (dB)	Reading (dBuV)	Level (dBuV/m)	Limits (dBuV/m)	Margin (dB)	Remark
1	61.590	12.28	1.60	16.31	30.20	40.00	9.80
2	93.990	16.37	2.00	13.31	31.68	43.50	11.82
3	133.680	19.89	2.40	12.79	35.08	43.50	8.42
4	199.830	22.09	3.00	10.79	35.88	43.50	7.62
5	231.690	22.25	3.30	6.17	31.71	46.00	14.29
6	300.700	14.52	3.90	12.30	30.71	46.00	15.29
7	372.800	17.12	4.60	13.96	35.69	46.00	10.31
8	407.800	17.31	4.90	13.42	35.62	46.00	10.38
9	553.400	19.40	6.80	6.68	32.88	46.00	13.12
10	624.800	21.31	6.20	8.41	35.92	46.00	10.08
11	672.400	22.85	6.40	13.96	43.22	46.00	2.78
12	696.900	23.32	6.50	10.94	40.76	46.00	5.24
13	959.400	26.38	7.60	4.43	38.42	46.00	7.58

Remarks: 1. Emission Level= Antenna Factor + Cable Loss + Reading.
 2. The emission levels that are 20dB below the official limit are not reported.



EMC Laboratory
 No.53-11, Tin-fu Tsun, Lin-kou Hsiang, Taipei
 County, Taiwan R.O.C. Post Code:24443
 Tel:+886-2-26092133 Fax:+886-2-26099303
 Email:ttemc@ttemc.com.tw

Data: 12 File: C:\Documents and Settings\Administrator\桌面\FUTUBA\ANT-3\ANT-3(RX)\Ant-3-1x.e Date: 2005-03-07

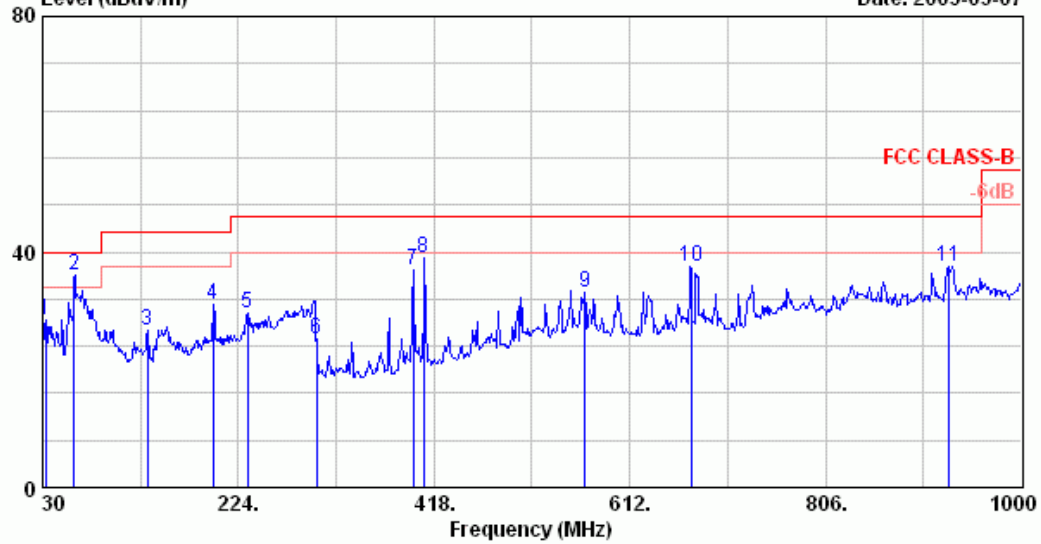

Site : A/C Chamber Date : 12
 Condition : 3m BBA9106/UHALP9108-A Polarity: VERTICAL
 Limit : FCC CLASS-B
 Env. / Ins. : 8593EM 18*C/62% Engineer: henning
 EUT : RF-Modem using digital modulation
 Power Rating : DC 3.9V M/N:FRH-SD07TU
 Test Mode : RX (2420MHz)---ANT3

	Freq. (MHz)	Ant. Factor (dB/m)	Cable Loss (dB)	Reading (dBuV)	Emission Level (dBuV/m)	Limits (dBuV/m)	Margin (dB)	Remark
1	33.240	22.11	1.10	5.36	28.57	40.00	11.43	
2	61.590	13.37	1.60	20.94	35.90	40.00	4.10	
3	133.680	19.23	2.40	4.96	26.59	43.50	16.91	
4	199.290	22.86	3.00	5.18	31.04	43.50	12.46	
5	233.040	24.76	3.30	1.67	29.73	46.00	16.27	
6	301.400	14.83	3.90	6.60	25.34	46.00	20.66	
7	397.300	17.67	4.80	14.35	36.82	46.00	9.18	
8	407.800	17.19	4.90	16.96	39.05	46.00	6.95	
9	567.400	22.08	6.50	4.54	33.12	46.00	12.88	
10	672.400	23.07	6.40	7.95	37.43	46.00	8.57	
11	927.900	25.91	7.50	4.17	37.58	46.00	8.42	

Remarks: 1. Emission Level= Antenna Factor + Cable Loss + Reading.
 2. The emission levels that are 20dB below the official limit are not reported.



EMC Laboratory
 No.53-11, Tin-fu Tsun, Lin-kou Hsiang, Taipei
 County, Taiwan R.O.C. Post Code:24443
 Tel:+886-2-26092133 Fax:+886-2-26099303
 Email:ttenc@ttenc.com.tw

Data: 13 File: C:\Documents and Settings\Administrator\桌面\FUTUBA\ANT-4\ANT-4\Ant-4.emi (14) Date: 2005-03-07

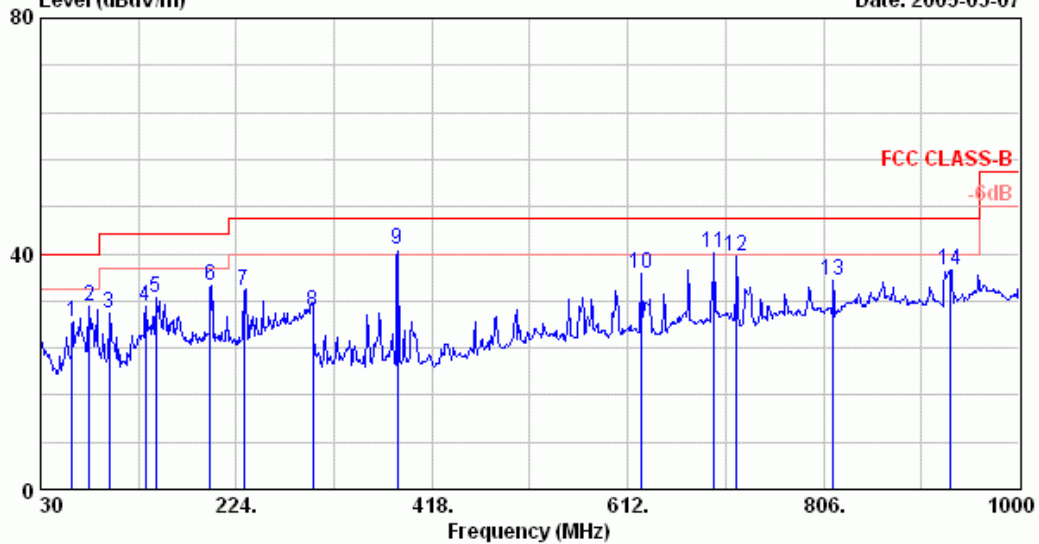

Site : A/C Chamber Date : 13
 Condition : 3m BBA9106/UHALP9108-A Polarity: HORIZONTAL
 Limit : FCC CLASS-B
 Env. / Ins. : 8593EM 18*C/62% Engineer: henning
 EUT : RF-Modem using digital modulation
 Power Rating : DC 3.9V M/N:FRH-SD07TU
 Test Mode : TX (2420MHz)---ANT4

Ant.	Cable	Emission					
Freq. (MHz)	Factor (dB/m)	Loss (dB)	Reading (dBuV)	Level (dBuV/m)	Limits (dBuV/m)	Margin (dB)	Remark
1	61.590	12.28	1.60	14.40	28.29	40.00	11.71
2	78.330	13.43	1.80	15.79	31.02	40.00	8.98
3	98.040	16.84	2.10	10.84	29.78	43.50	13.72
4	133.680	19.89	2.40	8.79	31.08	43.50	12.42
5	144.480	20.31	2.60	9.73	32.65	43.50	10.85
6	198.480	22.07	3.00	9.37	34.44	43.50	9.06
7	231.690	22.25	3.30	8.23	33.77	46.00	12.23
8	300.000	26.77	3.90	-0.35	30.32	46.00	15.68
9	383.300	17.33	4.62	18.78	40.74	46.00	5.26
10	624.800	21.31	6.20	9.23	36.74	46.00	9.26
11	696.900	23.32	6.50	10.44	40.26	46.00	5.74
12	719.300	22.30	6.60	10.53	39.43	46.00	6.57
13	815.900	23.89	7.00	4.56	35.45	46.00	10.55
14	932.100	25.17	7.50	4.57	37.24	46.00	8.76

Remarks: 1. Emission Level= Antenna Factor + Cable Loss + Reading.
 2. The emission levels that are 20dB below the official limit are not reported.



EMC Laboratory
 No.53-11, Tin-fu Tsun, Lin-kou Hsiang, Taipei
 County, Taiwan R.O.C. Post Code:24443
 Tel:+886-2-26092133 Fax:+886-2-26099303
 Email:ttenc@ttenc.com.tw

Data: 14 File: C:\Documents and Settings\Administrator\桌面\FUTUBA\ANT-4\ANT-4\Ant-4.emi (14)
 Level (dBuV/m) Date: 2005-03-07

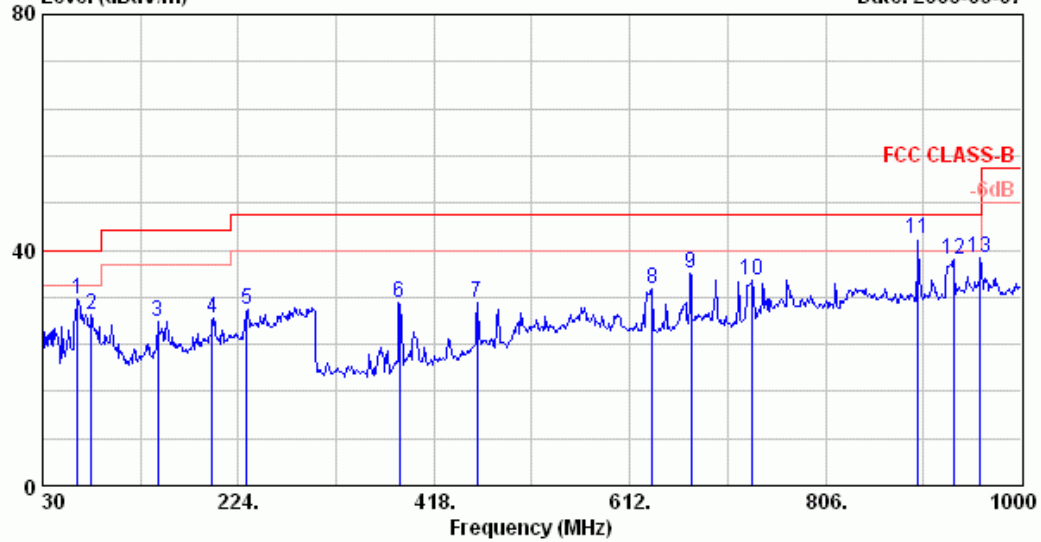

Site : A/C Chamber Date : 14
 Condition : 3m BBA9106/UHALP9108-A Polarity: VERTICAL
 Limit : FCC CLASS-B
 Env. / Ins. : 8593EM 18*C/62% Engineer: henning
 EUT : RF-Modem using digital modulation
 Power Rating : DC 3.9V M/N:FRH-SD07TU
 Test Mode : TX (2420MHz)---ANT4

Freq. (MHz)	Ant. Factor (dB/m)	Cable Loss (dB)	Reading (dBuV)	Emission Level (dBuV/m)	Limits (dBuV/m)	Margin (dB)	Remark
1	12.84	1.70	17.05	31.59	40.00	8.41	
2	13.92	1.80	13.32	29.04	40.00	10.96	
3	20.94	2.60	4.21	27.75	43.50	15.75	
4	22.74	3.00	2.82	28.56	43.50	14.94	
5	24.33	3.30	2.18	29.82	46.00	16.18	
6	17.08	4.62	9.27	30.97	46.00	15.03	
7	18.76	5.70	6.73	31.19	46.00	14.81	
8	21.13	6.30	6.09	33.52	46.00	12.48	
9	23.07	6.40	6.57	36.05	46.00	9.95	
10	22.98	6.70	5.09	34.77	46.00	11.23	
11	25.86	7.30	8.87	42.02	46.00	3.98	
12	26.27	7.50	4.75	38.52	46.00	7.48	
13	27.16	7.60	3.92	38.68	46.00	7.32	

Remarks: 1. Emission Level= Antenna Factor + Cable Loss + Reading.
 2. The emission levels that are 20dB below the official limit are not reported.



EMC Laboratory
 No.53-11, Tin-fu Tsun, Lin-kou Hsiang, Taipei
 County, Taiwan R.O.C. Post Code:24443
 Tel:+886-2-26092133 Fax:+886-2-26099303
 Email:ttenc@ttenc.com.tw

Data: 13 File: C:\Documents and Settings\Administrator\桌面\FUTUBA\ANT-4\ANT-4(M)\Ant-4(M).er Date: 2005-03-07

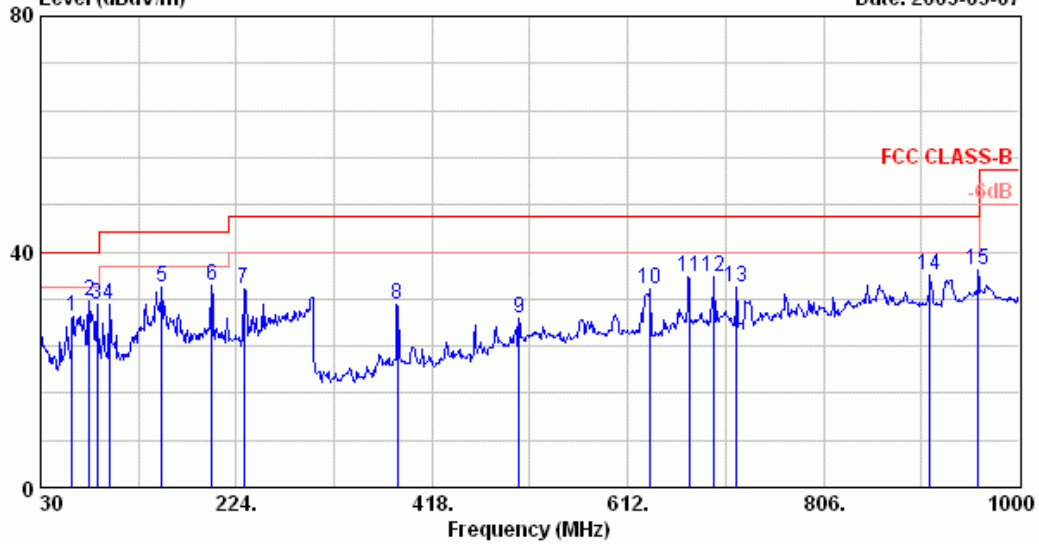

Site : A/C Chamber Date : 13
 Condition : 3m BBA9106/UHALP9108-A Polarity: HORIZONTAL
 Limit : FCC CLASS-B
 Env. / Ins. : 8593EM 18*C/62% Engineer: henning
 EUT : RF-Modem using digital modulation
 Power Rating : DC 3.9V M/N:FRH-SD07TU
 Test Mode : TX (2450MHz)---ANT4

Freq. (MHz)	Ant. Factor (dB/m)	Cable Loss (dB)	Reading (dBuV)	Emission Level (dBuV/m)	Limits (dBuV/m)	Margin (dB)	Remark
1	12.28	1.60	15.13	29.02	40.00	10.98	
2	13.43	1.80	16.45	31.68	40.00	8.32	
3	14.98	1.90	14.20	31.08	40.00	8.92	
4	16.84	2.10	11.99	30.93	43.50	12.57	
5	20.63	2.60	10.67	33.90	43.50	9.60	
6	22.09	3.00	9.10	34.19	43.50	9.31	
7	22.25	3.30	8.20	33.74	46.00	12.26	
8	17.33	4.62	9.22	31.18	46.00	14.82	
9	19.02	6.62	3.13	28.77	46.00	17.23	
10	20.94	6.30	6.57	33.82	46.00	12.18	
11	22.85	6.40	6.46	35.72	46.00	10.28	
12	23.32	6.50	5.84	35.66	46.00	10.34	
13	22.30	6.60	5.11	34.01	46.00	11.99	
14	24.99	7.40	3.52	35.91	46.00	10.09	
15	26.38	7.60	2.92	36.91	46.00	9.09	

Remarks: 1. Emission Level= Antenna Factor + Cable Loss + Reading.
 2. The emission levels that are 20dB below the official limit are not reported.



EMC Laboratory
 No.53-11, Tin-fu Tsun, Lin-kou Hsiang, Taipei
 County, Taiwan R.O.C. Post Code:24443
 Tel:+886-2-26092133 Fax:+886-2-26099303
 Email:ttenc@ttenc.com.tw

Data: 14 File: C:\Documents and Settings\Administrator\桌面\FUTUBA\ANT-4\ANT-4(M)\Ant-4(M).er Date: 2005-03-07

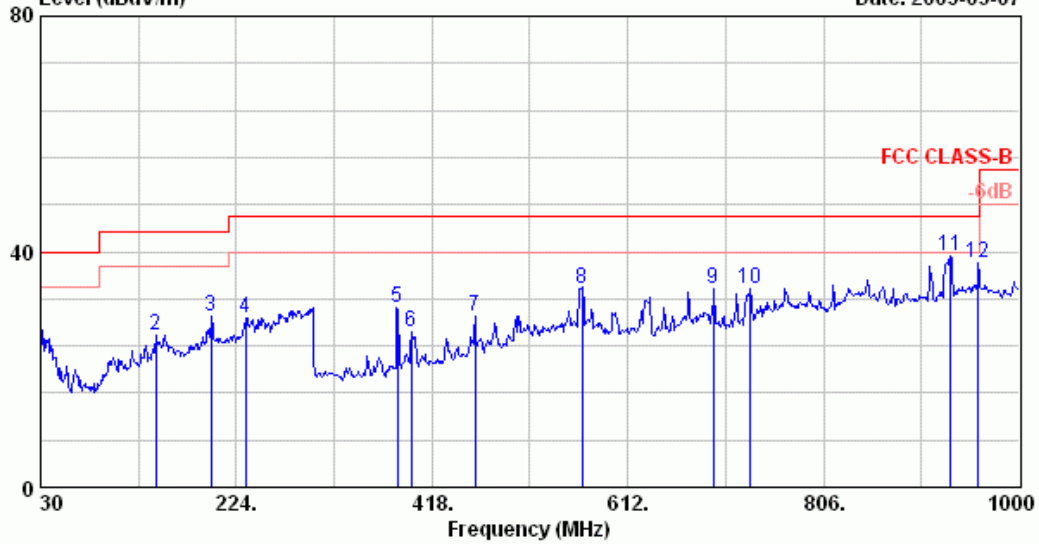

Site : A/C Chamber Date : 14
 Condition : 3m BBA9106/UHALP9108-A Polarity: VERTICAL
 Limit : FCC CLASS-B
 Env. / Ins. : 8593EM 18*C/62% Engineer: henning
 EUT : RF-Modem using digital modulation
 Power Rating : DC 3.9V M/N:FRH-SD07TU
 Test Mode : TX (2450MHz)---ANT4

	Ant. Cable		Emission				
Freq. (MHz)	Factor (dB/m)	Loss (dB)	Reading (dBuV)	Level (dBuV/m)	Limits (dBuV/m)	Margin (dB)	Remark
1	23.60	1.10	2.49	27.19	40.00	12.81	
2	20.94	2.60	2.22	25.76	43.50	17.74	
3	22.86	3.00	3.03	28.89	43.50	14.61	
4	24.76	3.30	0.66	28.72	46.00	17.28	
5	17.08	4.62	8.85	30.55	46.00	15.45	
6	17.67	4.80	3.98	26.45	46.00	19.55	
7	18.76	5.70	4.47	28.93	46.00	17.07	
8	22.08	6.51	5.21	33.80	46.00	12.20	
9	22.93	6.50	4.20	33.63	46.00	12.37	
10	22.98	6.70	3.91	33.59	46.00	12.41	
11	26.17	7.50	5.62	39.29	46.00	6.71	
12	27.16	7.60	3.44	38.20	46.00	7.80	

Remarks: 1. Emission Level= Antenna Factor + Cable Loss + Reading.
 2. The emission levels that are 20dB below the official limit are not reported.



EMC Laboratory
 No.53-11, Tin-fu Tsun, Lin-kou Hsiang, Taipei
 County, Taiwan R.O.C. Post Code:24443
 Tel:+886-2-26092133 Fax:+886-2-26099303
 Email:ttenc@ttenc.com.tw

Data: 12 File: C:\Documents and Settings\Administrator\桌面\ANT-H\ANT-4(H)\ANT-4EE\Ant-4(H).er Date: 2005-04-13

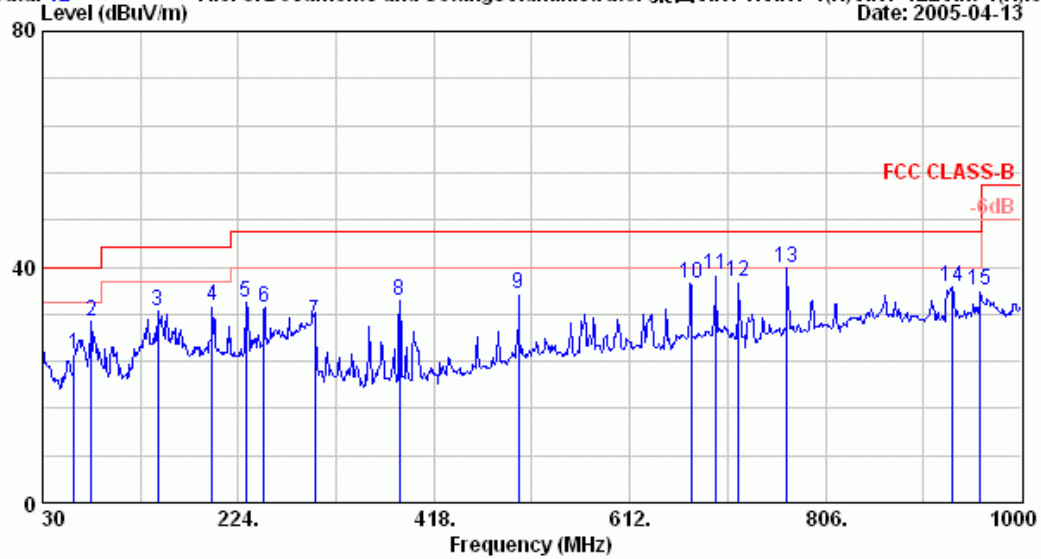

Site : A/C Chamber Date : 12
 Condition : 3m BBA9106/UHALP9108-A Polarity: HORIZONTAL
 Limit : FCC CLASS-B
 Env. / Ins. : 8593EM 21*C/59% Engineer: henning
 EUT : RF-Modem using digital modulation
 Power Rating : DC 3.9V M/N:FRH-SD07TU
 Test Mode : TX (2473MHz)---ANT4

Ant.	Cable	Emission					
Freq. (MHz)	Factor (dB/m)	Loss (dB)	Reading (dBuV)	Level (dBuV/m)	Limits (dBuV/m)	Margin (dB)	Remark
1	61.590	12.28	1.60	11.31	25.20	40.00	14.80
2	78.330	13.43	1.80	15.48	30.71	40.00	9.29
3	144.480	20.31	2.60	9.73	32.65	43.50	10.85
4	198.480	22.07	3.00	8.25	33.32	43.50	10.18
5	231.690	22.25	3.30	8.32	33.86	46.00	12.14
6	249.780	23.83	3.50	5.77	33.10	46.00	12.90
7	300.000	26.77	3.90	0.20	30.87	46.00	15.13
8	384.050	17.36	4.70	12.34	34.39	46.00	11.61
9	501.420	18.95	6.52	9.95	35.43	46.00	10.57
10	672.400	22.85	6.40	7.99	37.25	46.00	8.75
11	696.900	23.32	6.50	8.77	38.59	46.00	7.41
12	719.300	22.30	6.60	8.58	37.48	46.00	8.52
13	768.170	23.87	6.80	9.19	39.86	46.00	6.14
14	931.400	25.11	7.50	4.04	36.65	46.00	9.35
15	959.400	26.38	7.60	1.92	35.91	46.00	10.09

Remarks: 1. Emission Level= Antenna Factor + Cable Loss + Reading.
 2. The emission levels that are 20dB below the official limit are not reported.



EMC Laboratory
 No.53-11, Tin-fu Tsun, Lin-kou Hsiang, Taipei
 County, Taiwan R.O.C. Post Code:24443
 Tel:+886-2-26092133 Fax:+886-2-26099303
 Email:ttenc@ttenc.com.tw

Data: 11 File: C:\Documents and Settings\Administrator\桌面\ANT-H\ANT-4(H)\ANT-4EE\Ant-4(H).er Date: 2005-04-13

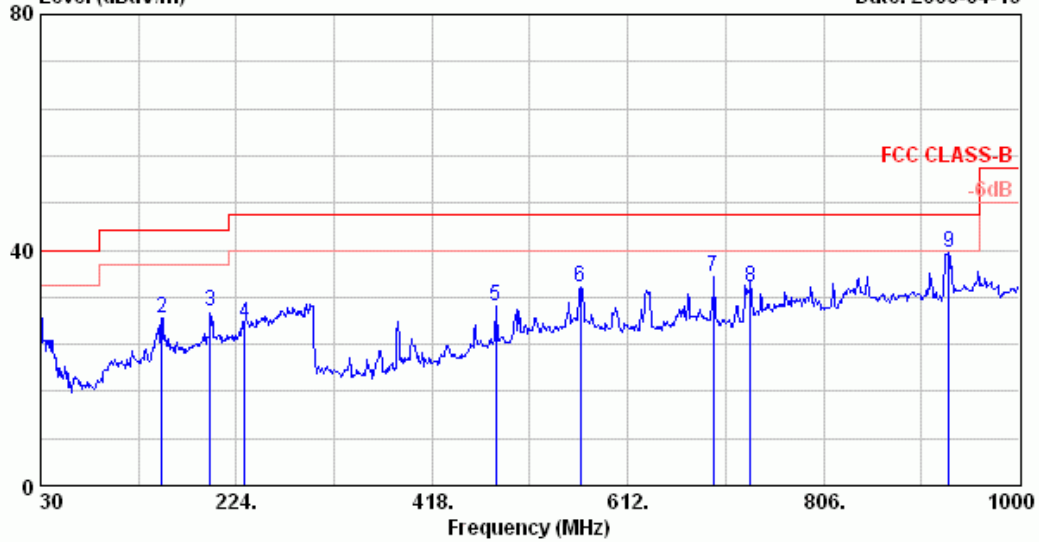

Site : A/C Chamber Date : 11
 Condition : 3m BBA9106/UHALP9108-A Polarity: VERTICAL
 Limit : FCC CLASS-B
 Env. / Ins. : 8593EM 21°C/59% Engineer: henning
 EUT : RF-Modem using digital modulation
 Power Rating : DC 3.9V M/N:FRH-SD07TU
 Test Mode : TX (2473MHz)---ANT4

Freq. (MHz)	Ant. Factor (dB/m)	Cable Loss (dB)	Reading (dBuV)	Emission Level (dBuV/m)	Limits (dBuV/m)	Margin (dB)	Remark
1	30.540	23.39	1.10	27.35	40.00	12.65	
2	150.150	22.05	2.60	28.42	43.50	15.08	
3	198.480	22.74	3.00	29.73	43.50	13.77	
4	232.500	24.76	3.30	-0.40	46.00	18.34	
5	481.300	18.93	6.10	5.44	46.00	15.54	
6	565.300	22.08	6.60	5.05	46.00	12.27	
7	696.900	22.93	6.50	5.96	46.00	10.61	
8	733.300	22.98	6.70	3.89	46.00	12.43	
9	930.160	26.07	7.50	6.08	46.00	6.35	

Remarks: 1. Emission Level= Antenna Factor + Cable Loss + Reading.
 2. The emission levels that are 20dB below the official limit are not reported.



EMC Laboratory
 No.53-11, Tin-fu Tsun, Lin-kou Hsiang, Taipei
 County, Taiwan R.O.C. Post Code:24443
 Tel:+886-2-26092133 Fax:+886-2-26099303
 Email:ttemc@ttemc.com.tw

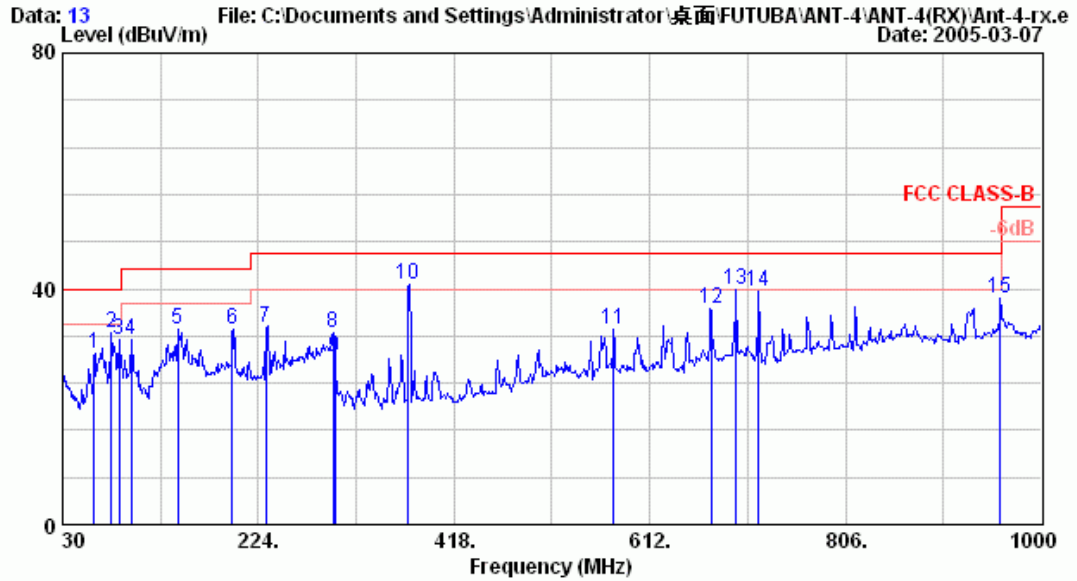

Site : A/C Chamber Date : 13
 Condition : 3m BBA9106/UHALP9108-A Polarity: HORIZONTAL
 Limit : FCC CLASS-B
 Env. / Ins. : 8593EM 18*C/62% Engineer: henning
 EUT : RF-Modem using digital modulation
 Power Rating : DC 3.9V M/N:FRH-SD07TU
 Test Mode : RX (2420MHz)---ANT4

	Ant.	Cable	Emission				
Freq. (MHz)	Factor (dB/m)	Loss (dB)	Reading (dBµV)	Level (dBµV/m)	Limits (dBµV/m)	Margin (dB)	Remark
1	61.590	12.28	1.60	15.22	29.11	40.00	10.89
2	78.330	13.43	1.80	17.37	32.60	40.00	7.40
3	85.890	14.98	1.90	14.60	31.48	40.00	8.52
4	98.040	16.84	2.10	12.50	31.44	43.50	12.06
5	144.480	20.31	2.60	10.13	33.05	43.50	10.45
6	198.480	22.07	3.00	8.14	33.21	43.50	10.29
7	231.690	22.25	3.30	7.87	33.41	46.00	12.59
8	298.380	26.72	3.90	1.90	32.52	46.00	13.48
9	300.000	26.77	3.90	-2.19	28.48	46.00	17.52
10	372.800	17.12	4.60	19.14	40.87	46.00	5.13
11	575.800	21.05	6.40	5.64	33.09	46.00	12.91
12	672.400	22.85	6.40	7.49	36.75	46.00	9.25
13	696.900	23.32	6.50	10.10	39.92	46.00	6.08
14	719.300	22.30	6.60	10.60	39.50	46.00	6.50
15	959.400	26.38	7.60	4.34	38.33	46.00	7.67

Remarks: 1. Emission Level= Antenna Factor + Cable Loss + Reading.
 2. The emission levels that are 20dB below the official limit are not reported.



EMC Laboratory
 No.53-11, Tin-fu Tsun, Lin-kou Hsiang, Taipei
 County, Taiwan R.O.C. Post Code:24443
 Tel:+886-2-26092133 Fax:+886-2-26099303
 Email:ttenc@ttenc.com.tw

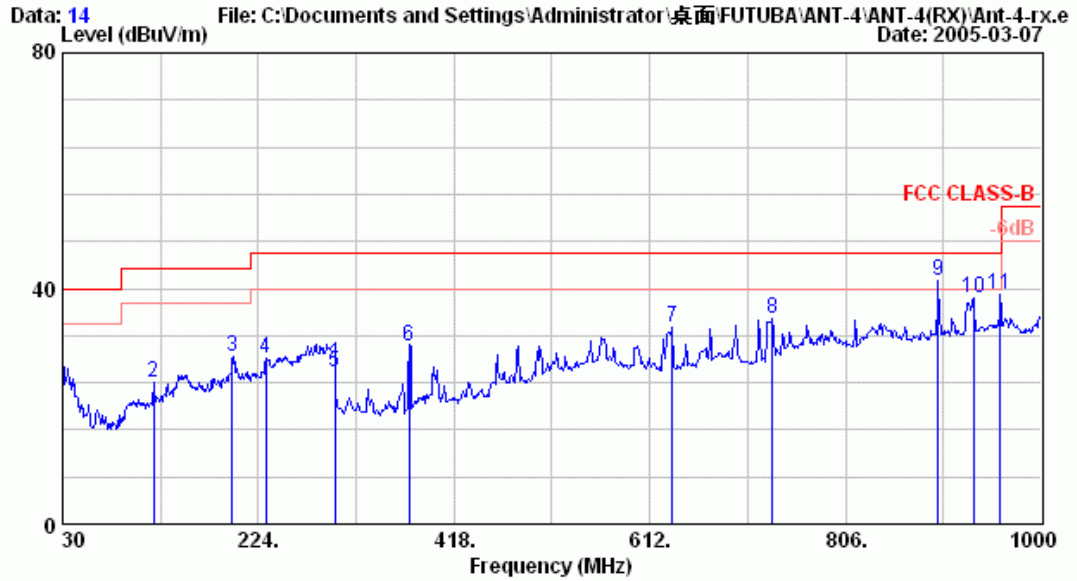

Site : A/C Chamber Date : 14
 Condition : 3m BBA9106/UHALP9108-A Polarity: VERTICAL
 Limit : FCC CLASS-B
 Env. / Ins. : 8593EM 18°C/62% Engineer: henning
 EUT : RF-Modem using digital modulation
 Power Rating : DC 3.9V M/N:FRH-SD07TU
 Test Mode : RX (2420MHz)---ANT4

	Ant.	Cable	Emission				
Freq. (MHz)	Factor (dB/m)	Loss (dB)	Reading (dBµV)	Level (dBµV/m)	Limits (dBµV/m)	Margin (dB)	Remark
1	30.270	23.60	1.10	1.74	26.44	40.00	13.56
2	120.180	17.58	2.30	4.26	24.14	43.50	19.36
3	198.480	22.74	3.00	2.55	28.29	43.50	15.21
4	231.690	24.33	3.30	0.64	28.27	46.00	17.73
5	300.000	26.86	3.90	-5.02	25.75	46.00	20.25
6	373.500	15.75	4.60	9.96	30.31	46.00	15.69
7	633.900	21.13	6.30	5.88	33.31	46.00	12.69
8	733.300	22.98	6.70	5.11	34.79	46.00	11.21
9	897.800	25.86	7.30	8.30	41.45	46.00	4.55
10	932.800	26.27	7.50	4.75	38.52	46.00	7.48
11	959.400	27.16	7.60	4.22	38.98	46.00	7.02

Remarks: 1. Emission Level= Antenna Factor + Cable Loss + Reading.
 2. The emission levels that are 20dB below the official limit are not reported.



EMC Laboratory
 No.53-11, Tin-fu Tsun, Lin-kou Hsiang, Taipei
 County, Taiwan R.O.C. Post Code:24443
 Tel:+886-2-26092133 Fax:+886-2-26099303
 Email:ttmc@ttmc.com.tw

Data: 12 File: C:\Documents and Settings\Administrator\桌面\FUTUBA\ANT-5\ANT-5\Ant-5.emi (14) Date: 2005-03-07

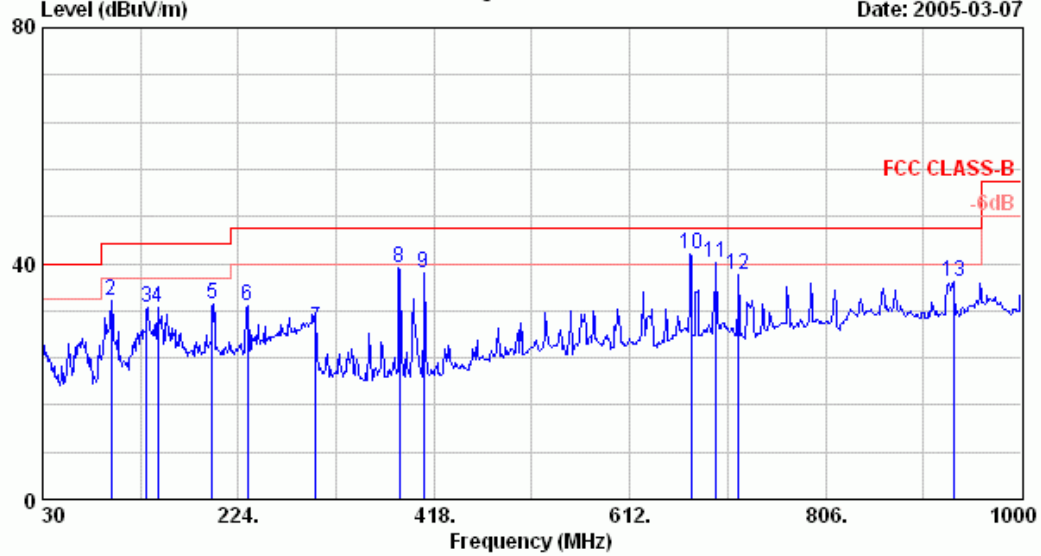

Site : A/C Chamber Date : 12
 Condition : 3m BBA9106/UHALP9108-A Polarity: HORIZONTAL
 Limit : FCC CLASS-B
 Env. / Ins. : 8593EM 18°C/62% Engineer: henning
 EUT : RF-Modem using digital modulation
 Power Rating : DC 3.9V M/N:FRH-SD07TU
 Test Mode : TX (2420MHz)---ANT5

	Ant.	Cable	Emission				
Freq. (MHz)	Factor (dB/m)	Loss (dB)	Reading (dBuV)	Level (dBuV/m)	Limits (dBuV/m)	Margin (dB)	Remark
1	30.270	24.86	1.10	0.05	26.00	40.00	14.00
2	98.040	16.84	2.10	14.86	33.80	43.50	9.70
3	133.140	19.87	2.40	10.20	32.47	43.50	11.03
4	144.480	20.31	2.60	9.66	32.58	43.50	10.92
5	198.480	22.07	3.00	8.14	33.21	43.50	10.29
6	233.040	22.36	3.30	7.27	32.94	46.00	13.06
7	300.700	14.52	3.90	10.49	28.90	46.00	17.10
8	383.300	17.33	4.62	17.43	39.39	46.00	6.61
9	407.800	17.31	4.90	16.17	38.37	46.00	7.63
10	672.400	22.85	6.40	12.31	41.57	46.00	4.43
11	696.900	23.32	6.50	10.30	40.12	46.00	5.88
12	719.300	22.30	6.60	9.33	38.23	46.00	7.77
13	932.800	25.23	7.50	4.28	37.01	46.00	8.99

Remarks: 1. Emission Level= Antenna Factor + Cable Loss + Reading.
 2. The emission levels that are 20dB below the official limit are not reported.



EMC Laboratory
 No.53-11, Tin-fu Tsun, Lin-kou Hsiang, Taipei
 County, Taiwan R.O.C. Post Code:24443
 Tel:+886-2-26092133 Fax:+886-2-26099303
 Email:ttenc@ttenc.com.tw

Data: 11 File: C:\Documents and Settings\Administrator\桌面\FUTUBA\ANT-5\ANT-5\Ant-5.emi (14)
 Level (dBuV/m) Date: 2005-03-07

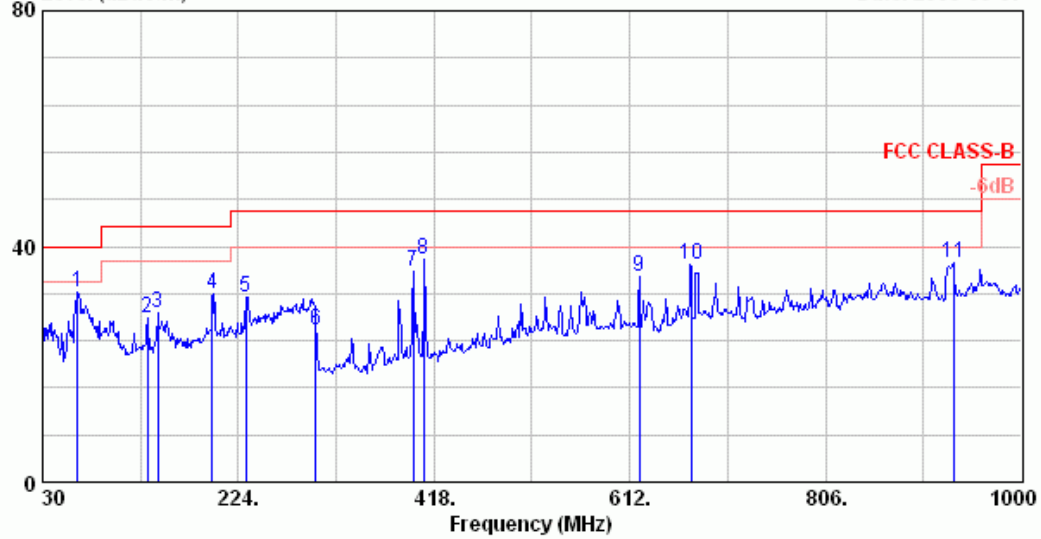

Site : A/C Chamber Date : 11
 Condition : 3m BBA9106/UHALP9108-A Polarity: VERTICAL
 Limit : FCC CLASS-B
 Env. / Ins. : 8593EM 18*C/62% Engineer: henning
 EUT : RF-Modem using digital modulation
 Power Rating : DC 3.9V M/N:FRH-SD07TU
 Test Mode : TX (2420MHz)---ANT5

	Ant. Factor	Cable Loss	Emission Reading	Emission Level	Limits	Margin	Remark
Freq. (MHz)	(dB/m)	(dB)	(dBuV)	(dBuV/m)	(dBuV/m)	(dB)	
1	12.84	1.70	17.69	32.23	40.00	7.77	
2	19.23	2.40	6.08	27.71	43.50	15.79	
3	20.94	2.60	5.23	28.77	43.50	14.73	
4	22.74	3.00	6.19	31.93	43.50	11.57	
5	24.33	3.30	3.82	31.45	46.00	14.55	
6	14.75	3.90	7.13	25.78	46.00	20.22	
7	17.67	4.80	13.36	35.83	46.00	10.17	
8	17.19	4.90	15.80	37.89	46.00	8.11	
9	21.20	6.20	7.37	34.77	46.00	11.23	
10	23.07	6.40	7.35	36.82	46.00	9.18	
11	26.27	7.50	3.38	37.15	46.00	8.85	

Remarks: 1. Emission Level= Antenna Factor + Cable Loss + Reading.
 2. The emission levels that are 20dB below the official limit are not reported.



EMC Laboratory
 No.53-11, Tin-fu Tsun, Lin-kou Hsiang, Taipei
 County, Taiwan R.O.C. Post Code:24443
 Tel:+886-2-26092133 Fax:+886-2-26099303
 Email:ttemc@ttemc.com.tw

Data: 11 File: C:\Documents and Settings\Administrator\桌面\FUTUBA\ANT-5\ANT-5(M)\Ant-5(M).er Date: 2005-03-07

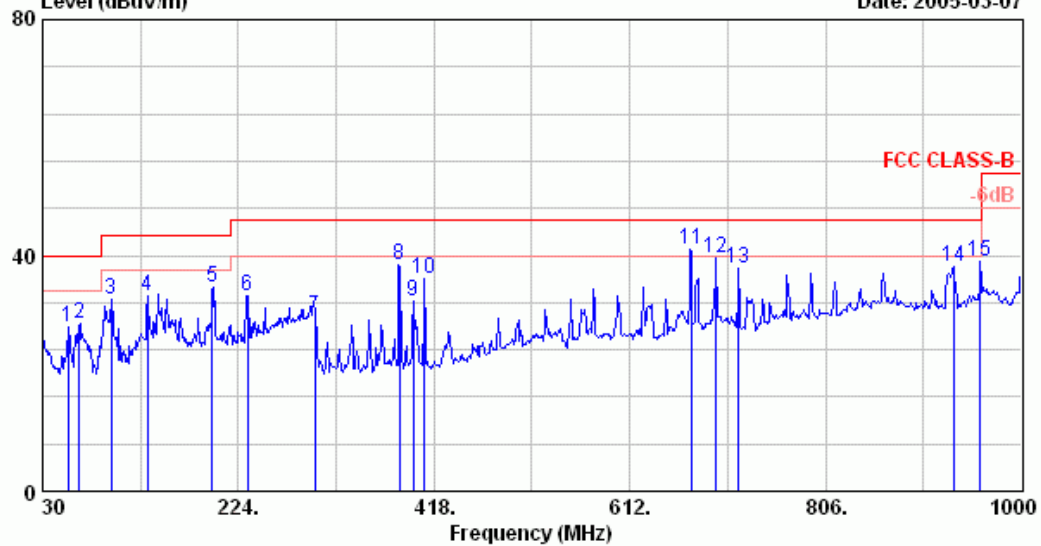

Site : A/C Chamber Date : 11
 Condition : 3m BBA9106/UHALP9108-A Polarity: HORIZONTAL
 Limit : FCC CLASS-B
 Env. / Ins. : 8593EM 18°C/62% Engineer: henning
 EUT : RF-Modem using digital modulation
 Power Rating : DC 3.9V M/N:FRH-SD07TU
 Test Mode : TX (2450MHz)---ANT5

	Ant.	Cable	Emission				
Freq. (MHz)	Factor (dB/m)	Loss (dB)	Reading (dBuV)	Level (dBuV/m)	Limits (dBuV/m)	Margin (dB)	Remark
1	55.380	14.39	1.50	12.00	27.89	40.00	12.11
2	66.180	11.78	1.70	15.06	28.54	40.00	11.46
3	98.040	16.84	2.10	13.61	32.55	43.50	10.95
4	133.680	19.89	2.40	10.88	33.17	43.50	10.33
5	198.480	22.07	3.00	9.37	34.44	43.50	9.06
6	233.040	22.36	3.30	7.53	33.20	46.00	12.80
7	300.000	26.77	3.90	-0.95	29.72	46.00	16.28
8	383.300	17.33	4.62	16.45	38.41	46.00	7.59
9	397.300	17.64	4.80	9.81	32.25	46.00	13.75
10	407.800	17.31	4.90	13.90	36.10	46.00	9.90
11	672.400	22.85	6.40	11.77	41.03	46.00	4.97
12	696.900	23.32	6.50	9.63	39.45	46.00	6.55
13	719.300	22.30	6.60	9.03	37.93	46.00	8.07
14	932.800	25.23	7.50	5.43	38.16	46.00	7.84
15	959.400	26.38	7.60	4.95	38.94	46.00	7.06

Remarks: 1. Emission Level= Antenna Factor + Cable Loss + Reading.
 2. The emission levels that are 20dB below the official limit are not reported.



EMC Laboratory
 No.53-11, Tin-fu Tsun, Lin-kou Hsiang, Taipei
 County, Taiwan R.O.C. Post Code:24443
 Tel:+886-2-26092133 Fax:+886-2-26099303
 Email:ttenc@ttenc.com.tw

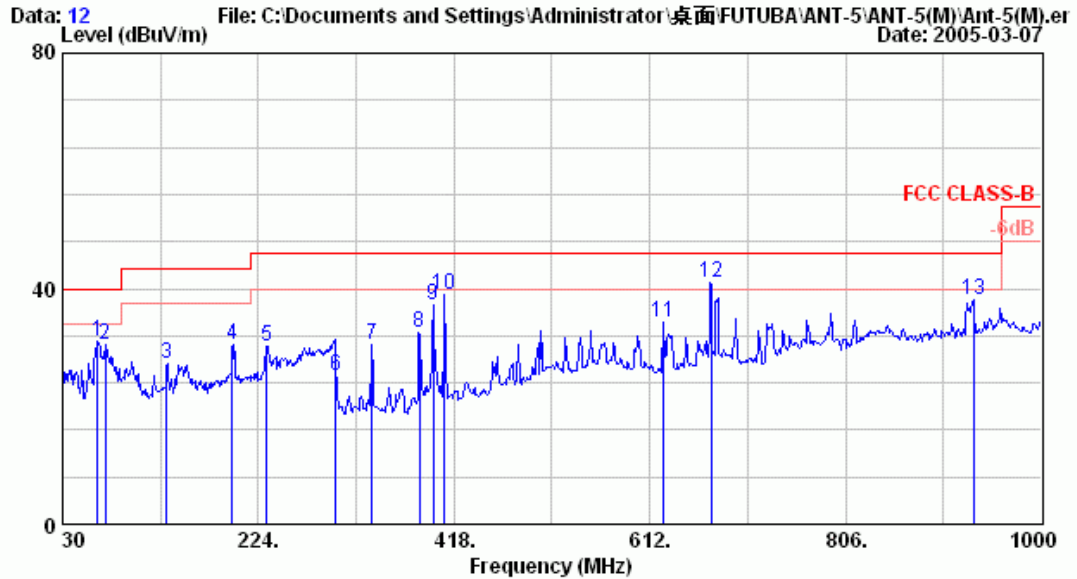

Site : A/C Chamber Date : 12
 Condition : 3m BBA9106/UHALP9108-A Polarity: VERTICAL
 Limit : FCC CLASS-B
 Env. / Ins. : 8593EM 18*C/62% Engineer: henning
 EUT : RF-Modem using digital modulation
 Power Rating : DC 3.9V M/N:FRH-SD07TU
 Test Mode : TX (2450MHz)---ANT5

Freq. (MHz)	Ant. Factor (dB/m)	Cable Loss (dB)	Reading (dBuV)	Emission			Margin (dB)	Remark
				Level (dBuV/m)	Limits (dBuV/m)			
1	64.830	12.84	1.70	16.38	30.92	40.00	9.08	
2	72.390	12.96	1.80	15.64	30.40	40.00	9.60	
3	133.140	19.09	2.40	5.63	27.11	43.50	16.39	
4	198.480	22.74	3.00	4.82	30.56	43.50	12.94	
5	231.960	24.33	3.30	2.58	30.21	46.00	15.79	
6	300.700	14.75	3.90	6.44	25.09	46.00	20.91	
7	336.400	15.54	4.20	10.88	30.62	46.00	15.38	
8	383.300	17.08	4.62	10.80	32.50	46.00	13.50	
9	397.300	17.67	4.80	14.79	37.26	46.00	8.74	
10	407.800	17.19	4.90	16.87	38.96	46.00	7.04	
11	624.800	21.15	6.20	6.94	34.29	46.00	11.71	
12	672.400	23.07	6.40	11.45	40.93	46.00	5.07	
13	932.800	26.27	7.50	4.23	38.00	46.00	8.00	

Remarks: 1. Emission Level= Antenna Factor + Cable Loss + Reading.
 2. The emission levels that are 20dB below the official limit are not reported.



EMC Laboratory
 No.53-11, Tin-fu Tsun, Lin-kou Hsiang, Taipei
 County, Taiwan R.O.C. Post Code:24443
 Tel:+886-2-26092133 Fax:+886-2-26099303
 Email:ttenc@ttenc.com.tw

Data: 12 File: C:\Documents and Settings\Administrator\桌面\ANT-H\ANT-5(H)\ANT-5EE\Ant-5(H).er Date: 2005-04-13

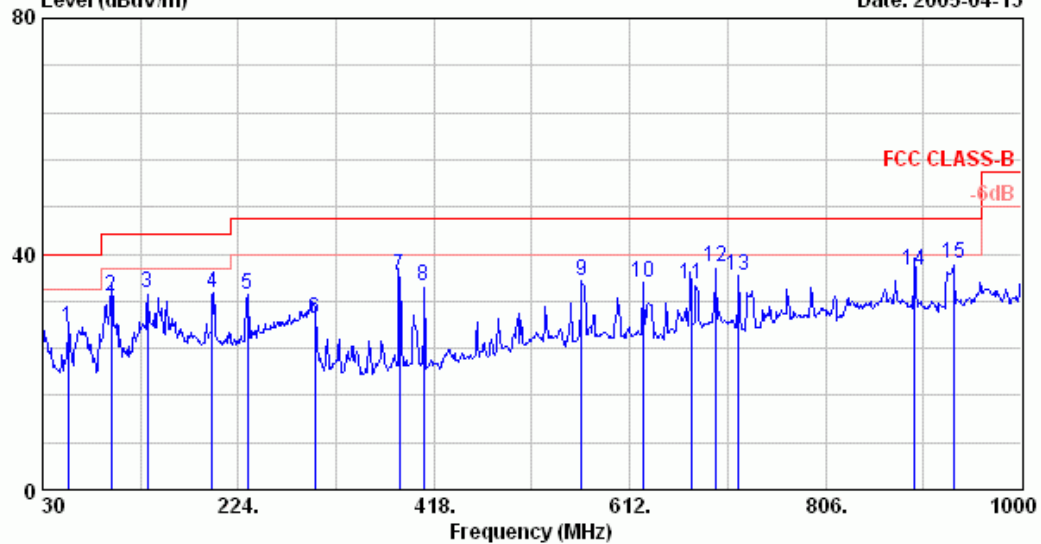

Site : A/C Chamber Date : 12
 Condition : 3m BBA9106/UHALP9108-A Polarity: HORIZONTAL
 Limit : FCC CLASS-B
 Env. / Ins. : 8593EM 21*C/59% Engineer: henning
 EUT : RF-Modem using digital modulation
 Power Rating : DC 3.9V M/N:FRH-SD07TU
 Test Mode : TX (2473MHz)---ANTS

Freq. (MHz)	Ant. Factor (dB/m)	Cable Loss (dB)	Reading (dBµV)	Emission		Margin (dB)	Remark
				Level (dBµV/m)	Limits (dBµV/m)		
1	14.39	1.50	11.61	27.50	40.00	12.50	
2	16.84	2.10	14.01	32.95	43.50	10.55	
3	19.89	2.40	11.04	33.33	43.50	10.17	
4	22.07	3.00	8.23	33.30	43.50	10.20	
5	22.36	3.30	7.36	33.03	46.00	12.97	
6	26.77	3.90	-1.51	29.16	46.00	16.84	
7	17.33	4.62	14.43	36.39	46.00	9.61	
8	17.31	4.90	12.28	34.48	46.00	11.52	
9	20.42	6.60	8.47	35.49	46.00	10.51	
10	21.31	6.20	7.52	35.03	46.00	10.97	
11	22.85	6.40	5.71	34.97	46.00	11.03	
12	23.32	6.50	7.93	37.75	46.00	8.25	
13	22.30	6.60	7.36	36.26	46.00	9.74	
14	25.02	7.30	4.89	37.21	46.00	8.79	
15	25.23	7.50	5.57	38.30	46.00	7.70	

Remarks: 1. Emission Level= Antenna Factor + Cable Loss + Reading.
 2. The emission levels that are 20dB below the official limit are not reported.



EMC Laboratory
 No.53-11, Tin-fu Tsun, Lin-kou Hsiang, Taipei
 County, Taiwan R.O.C. Post Code:24443
 Tel:+886-2-26092133 Fax:+886-2-26099303
 Email:ttenc@ttenc.com.tw

Data: 11 File: C:\Documents and Settings\Administrator\桌面\ANT-H\ANT-5(H)\ANT-5EE\Ant-5(H).er Date: 2005-04-13

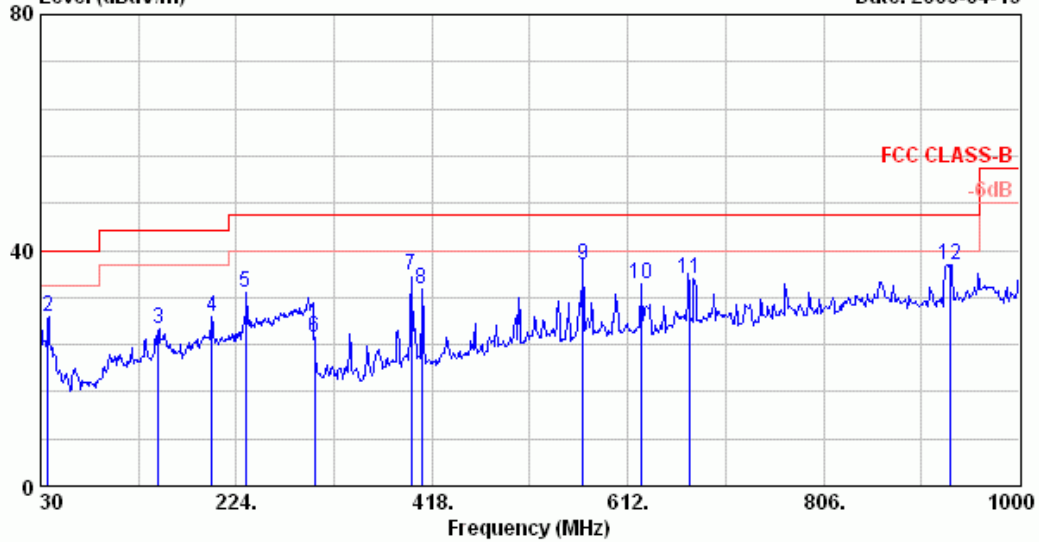

Site : A/C Chamber Date : 11
 Condition : 3m BBA9106/UHALP9108-A Polarity: VERTICAL
 Limit : FCC CLASS-B
 Env. / Ins. : 8593EM 21°C/59% Engineer: henning
 EUT : RF-Modem using digital modulation
 Power Rating : DC 3.9V M/N:FRH-SD07TU
 Test Mode : TX (2473MHz)---ANT5

	Freq. (MHz)	Ant. Factor (dB/m)	Cable Loss (dB)	Reading (dBuV)	Emission Level (dBuV/m)	Limits (dBuV/m)	Margin (dB)	Remark
1	30.000	23.60	1.10	2.60	27.30	40.00	12.70	
2	37.020	21.74	1.20	5.69	28.63	40.00	11.37	
3	146.640	21.57	2.50	2.61	26.67	43.50	16.83	
4	199.830	22.86	3.00	2.78	28.64	43.50	14.86	
5	233.040	24.76	3.30	4.74	32.80	46.00	13.20	
6	301.400	14.83	3.90	6.33	25.06	46.00	20.94	
7	397.300	17.67	4.80	13.14	35.61	46.00	10.39	
8	407.800	17.19	4.90	11.24	33.33	46.00	12.67	
9	567.380	22.08	6.50	8.88	37.46	46.00	8.54	
10	624.800	21.15	6.20	7.04	34.39	46.00	11.61	
11	672.400	23.07	6.40	5.57	35.04	46.00	10.96	
12	932.100	26.22	7.50	3.67	37.39	46.00	8.61	

Remarks: 1. Emission Level= Antenna Factor + Cable Loss + Reading.
 2. The emission levels that are 20dB below the official limit are not reported.



EMC Laboratory
 No.53-11, Tin-fu Tsun, Lin-kou Hsiang, Taipei
 County, Taiwan R.O.C. Post Code:24443
 Tel:+886-2-26092133 Fax:+886-2-26099303
 Email:ttenc@ttenc.com.tw

Data: 14 File: C:\Documents and Settings\Administrator\桌面\FUTUBA\ANT-5\ANT-5(RX)\Ant-5-rx.e Date: 2005-03-07

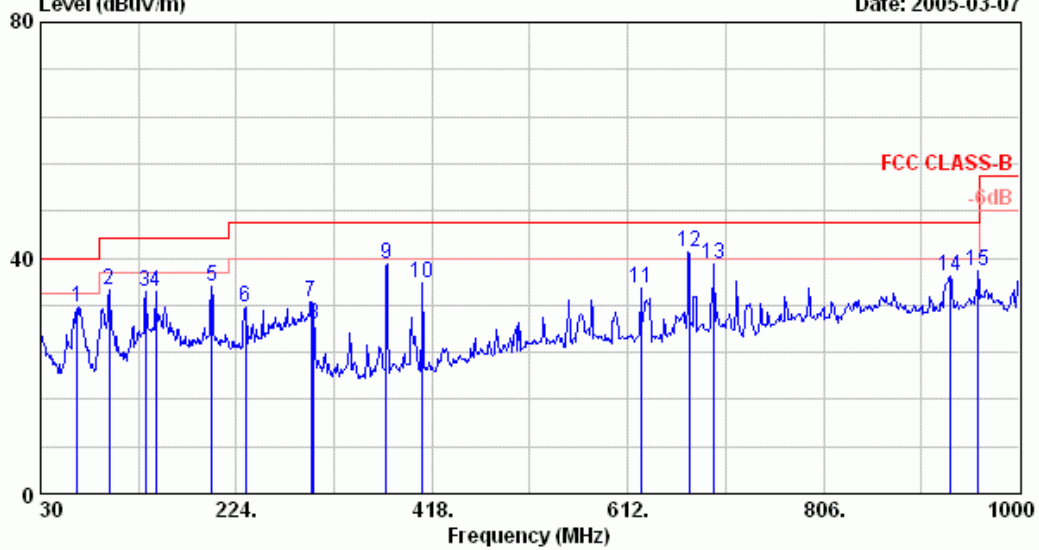

Site : A/C Chamber Date : 14
 Condition : 3m BBA9106(A3L) Polarity: HORIZONTAL
 Limit : FCC CLASS-B
 Env. / Ins. : 8593EM 18*C/62% Engineer: henning
 EUT : RF-Modem using digital modulation
 Power Rating : DC 3.9V M/N:FRH-SD07TU
 Test Mode : RX (2420MHz)---ANTS

Freq. (MHz)	Ant. Factor (dB/m)	Cable Loss (dB)	Reading (dBµV)	Emission		Margin (dB)	Remark
				Level (dBµV/m)	Limits (dBµV/m)		
1	11.78	1.70	44.56	31.68	40.00	8.32	
2	16.87	2.10	42.03	34.70	43.50	8.80	
3	19.89	2.40	38.15	34.35	43.50	9.15	
4	20.31	2.60	37.38	34.26	43.50	9.24	
5	22.08	3.00	35.91	35.19	43.50	8.31	
6	22.40	3.30	31.67	31.60	46.00	14.40	
7	26.68	3.98	27.59	32.55	46.00	13.45	
8	14.52	3.90	35.95	28.64	46.00	17.36	
9	17.13	4.60	43.58	38.92	46.00	7.08	
10	17.28	4.90	40.06	35.62	46.00	10.38	
11	21.30	6.20	34.64	34.89	46.00	11.11	
12	22.85	6.40	39.21	41.12	46.00	4.88	
13	23.31	6.50	36.46	38.87	46.00	7.13	
14	25.11	7.50	31.19	36.90	46.00	9.10	
15	26.38	7.60	30.75	37.91	46.00	8.09	

Remarks: 1. Emission Level= Antenna Factor + Cable Loss + Reading.
 2. The emission levels that are 20dB below the official limit are not reported.



EMC Laboratory
 No.53-11, Tin-fu Tsun, Lin-kou Hsiang, Taipei
 County, Taiwan R.O.C. Post Code:24443
 Tel:+886-2-26092133 Fax:+886-2-26099303
 Email:ttenc@ttenc.com.tw

Data: 13 File: C:\Documents and Settings\Administrator\桌面\FUTUBA\ANT-5\ANT-5(RX)\Ant-5-1x.e Date: 2005-03-07

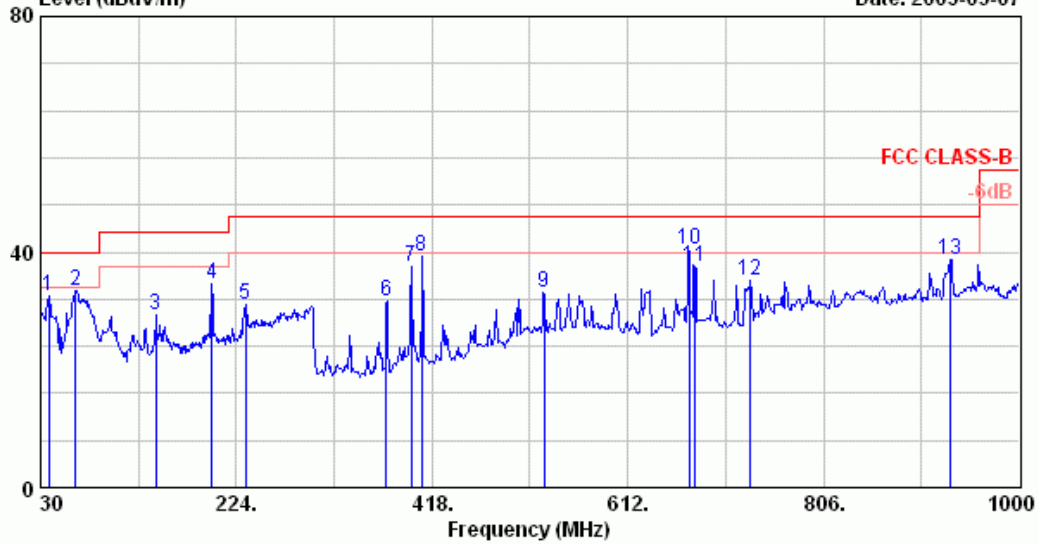

Site : A/C Chamber Date : 13
 Condition : 3m BBA9106/UHALP9108-A Polarity: VERTICAL
 Limit : FCC CLASS-B
 Env. / Ins. : 8593EM 18*C/62% Engineer: henning
 EUT : RF-Modem using digital modulation
 Power Rating : DC 3.9V M/N:FRH-SD07TU
 Test Mode : RX (2420MHz)---ANT5

Freq. (MHz)	Ant. Factor (dB/m)	Cable Loss (dB)	Reading (dBuV)	Emission Level (dBuV/m)	Limits (dBuV/m)	Margin (dB)	Remark
1	21.49	1.20	9.84	32.53	40.00	7.47	
2	13.06	1.67	18.60	33.32	40.00	6.68	
3	20.94	2.60	5.77	29.31	43.50	14.19	
4	22.86	3.00	8.69	34.55	43.50	8.95	
5	24.76	3.30	2.90	30.96	46.00	15.04	
6	15.78	4.60	11.26	31.64	46.00	14.36	
7	17.67	4.80	15.18	37.65	46.00	8.35	
8	17.19	4.90	17.17	39.26	46.00	6.74	
9	20.22	6.90	6.08	33.21	46.00	12.79	
10	23.07	6.40	11.05	40.53	46.00	5.47	
11	23.43	6.40	7.68	37.50	46.00	8.50	
12	22.98	6.70	5.48	35.16	46.00	10.84	
13	26.22	7.50	4.93	38.65	46.00	7.35	

Remarks: 1. Emission Level= Antenna Factor + Cable Loss + Reading.
 2. The emission levels that are 20dB below the official limit are not reported.

3.6.2. Above 1GHz Frequency Range Measurement Results

Date of Test : Mar. 05, 2005 Temperature : 18

EUT : RF-Modem using digital modulation w/
Pencil type antenna Humidity : 62%

Test Mode : Transmitting Mode, Frequency: 2420MHz

	Emission Frequency MHz	Antenna Factor dB/m	Cable Loss dB	Meter Reading Horizontal dBµV	Emission Level Horizontal dBµV/m	Limits dBµV/m	Margin dB
Peak	1001.678	25.20	4.18	11.21	40.59	74.00	33.41
	1198.004	25.29	4.58	10.92	40.79	74.00	33.21
	1313.786	25.33	4.88	12.81	43.02	74.00	30.98
	1332.244	25.34	4.94	11.27	41.55	74.00	32.45
	1468.162	25.39	5.33	19.57	50.29	74.00	23.71
	1726.574	26.58	7.00	8.48	42.06	74.00	31.94
Average	1001.678	25.20	4.18	6.21	35.59	54.00	18.41
	1198.004	25.29	4.58	4.92	34.79	54.00	19.21
	1313.786	25.33	4.88	6.81	37.02	54.00	16.98
	1332.244	25.34	4.94	5.27	35.55	54.00	18.45
	1468.162	25.39	5.33	12.57	43.29	54.00	10.71
	1726.574	26.58	7.00	5.48	39.06	54.00	14.94

	Emission Frequency MHz	Antenna Factor dB/m	Cable Loss dB	Meter Reading Vertical dBµV	Emission Level Vertical dBµV/m	Limits dBµV/m	Margin dB
Peak	1062.086	25.23	4.31	11.75	41.29	74.00	32.71
	1196.326	25.29	4.58	13.44	43.31	74.00	30.69
	1263.446	25.32	4.71	12.25	42.28	74.00	31.72
	1360.770	25.35	5.03	8.78	39.16	74.00	34.84
	1468.162	25.39	5.33	17.04	47.76	74.00	26.24
	1728.252	26.58	7.04	8.35	41.97	74.00	32.03
Peak	1062.086	25.23	4.31	5.75	35.29	54.00	18.71
	1196.326	25.29	4.58	7.44	37.31	54.00	16.69
	1263.446	25.32	4.71	6.25	36.28	54.00	17.72
	1360.770	25.35	5.03	2.78	33.16	54.00	20.84
	1468.162	25.39	5.33	11.04	41.76	54.00	12.24
	1728.252	26.58	7.04	2.35	35.97	54.00	18.03

Remark : 1. Emission Level = Antenna Factor + Cable Loss + Meter Reading.
2. Measurement was up to 25GHz, but the emissions level were too low against the official limit and not report.

Date of Test : Mar. 05, 2005 Temperature : 18

EUT : RF-Modem using digital modulation w/
Pencil type antenna Humidity : 62%

Test Mode : Transmitting Mode, Frequency: 2450MHz

	Emission Frequency MHz	Antenna Factor dB/m	Cable Loss dB	Meter Reading Horizontal dBµV	Emission Level Horizontal dBµV/m	Limits dBµV/m	Margin dB
Peak	1001.678	25.20	4.18	12.46	41.84	74.00	32.16
	1112.426	25.25	4.42	10.32	39.99	74.00	34.01
	1196.326	25.29	4.58	11.45	41.32	74.00	32.68
	1426.212	25.38	5.22	9.29	39.89	74.00	34.11
	1464.806	25.39	5.33	16.82	47.54	74.00	26.46
	2068.886	27.96	5.95	9.03	42.94	74.00	31.06
Average	1001.678	25.20	4.18	6.46	35.84	54.00	18.16
	1112.426	25.25	4.42	4.32	33.99	54.00	20.01
	1196.326	25.29	4.58	5.45	35.32	54.00	18.68
	1426.212	25.38	5.22	4.29	34.89	54.00	19.11
	1464.806	25.39	5.33	10.82	41.54	54.00	12.46
	2068.886	27.96	5.95	4.03	37.94	54.00	16.06

	Emission Frequency MHz	Antenna Factor dB/m	Cable Loss dB	Meter Reading Vertical dBµV	Emission Level Vertical dBµV/m	Limits dBµV/m	Margin dB
Peak	1063.764	25.23	4.32	13.82	43.37	74.00	30.63
	1198.004	25.29	4.58	10.22	40.09	74.00	33.91
	1263.446	25.32	4.71	10.54	40.57	74.00	33.43
	1330.566	25.34	4.93	10.23	40.50	74.00	33.50
	1464.806	25.39	5.33	13.79	44.51	74.00	29.49
	1686.302	26.38	6.73	8.58	41.69	74.00	32.31
	1716.506	26.53	6.92	22.44	55.89	74.00	18.11
	1959.816	27.63	6.06	7.98	41.67	74.00	32.33
	2068.886	27.96	5.95	9.08	42.99	74.00	31.01
	Average	1063.764	25.23	4.32	7.82	37.37	54.00
1198.004		25.29	4.58	4.22	34.09	54.00	19.91
1263.446		25.32	4.71	4.54	34.57	54.00	19.43
1330.566		25.34	4.93	4.23	34.50	54.00	19.50
1464.806		25.39	5.33	7.79	38.51	54.00	15.49
1686.302		26.38	6.73	2.58	35.69	54.00	18.31
1716.506		26.53	6.92	11.44	44.89	54.00	9.11
1959.816		27.63	6.06	1.98	35.67	54.00	18.33
2068.886		27.96	5.95	3.08	36.99	54.00	17.01

Remark : 1. Emission Level = Antenna Factor + Cable Loss + Meter Reading.
2. Measurement was up to 25GHz, but the emissions level were too low against the official limit and not report.

Date of Test : Apr. 13, 2005 Temperature : 21

EUT : RF-Modem using digital modulation w/
Pencil type antenna Humidity : 59%

Test Mode : Transmitting Mode, Frequency: 2473MHz

	Emission Frequency MHz	Antenna Factor dB/m	Cable Loss dB	Meter Reading Horizontal dBµV	Emission Level Horizontal dBµV/m	Limits dBµV/m	Margin dB
Peak	1003.356	25.20	4.18	12.59	41.97	74.00	32.03
	1196.326	25.29	4.58	10.17	40.04	74.00	33.96
	1347.346	25.35	4.98	7.54	37.87	74.00	36.13
	1464.806	25.39	5.33	15.52	46.24	74.00	27.76
	1599.046	25.93	6.14	12.32	44.39	74.00	29.61
	1724.896	26.58	7.00	9.82	43.40	74.00	30.60
	1812.152	26.98	6.85	7.91	41.74	74.00	32.26
	2097.412	28.01	5.98	9.43	43.42	74.00	30.58
Average	1003.356	25.20	4.18	6.59	35.97	54.00	18.03
	1196.326	25.29	4.58	5.17	35.04	54.00	18.96
	1347.346	25.35	4.98	2.54	32.87	54.00	21.13
	1464.806	25.39	5.33	10.52	41.24	54.00	12.76
	1599.046	25.93	6.14	7.32	39.39	54.00	14.61
	1724.896	26.58	7.00	3.82	37.40	54.00	16.60
	1812.152	26.98	6.85	2.91	36.74	54.00	17.26
	2097.412	28.01	5.98	4.43	38.42	54.00	15.58

	Emission Frequency MHz	Antenna Factor dB/m	Cable Loss dB	Meter Reading Vertical dBµV	Emission Level Vertical dBµV/m	Limits dBµV/m	Margin dB
Peak	1001.678	25.20	4.18	10.13	39.51	74.00	34.49
	1065.442	25.23	4.32	9.62	39.17	74.00	34.83
	1199.682	25.29	4.59	11.33	41.21	74.00	32.79
	1263.446	25.32	4.71	9.47	39.50	74.00	34.50
	1325.532	25.34	4.91	8.40	38.65	74.00	35.35
	1384.262	25.36	5.10	8.58	39.04	74.00	34.96
	1464.806	25.39	5.33	18.50	49.22	74.00	24.78
	1758.456	26.72	7.15	19.44	53.31	74.00	20.69
	2097.412	28.01	5.98	10.25	44.24	74.00	29.76
Average	1001.678	25.20	4.18	5.13	34.51	54.00	19.49
	1065.442	25.23	4.32	3.62	33.17	54.00	20.83
	1199.682	25.29	4.59	5.33	35.21	54.00	18.79
	1263.446	25.32	4.71	3.47	33.50	54.00	20.50
	1325.532	25.34	4.91	2.40	32.65	54.00	21.35
	1384.262	25.36	5.10	2.58	33.04	54.00	20.96
	1464.806	25.39	5.33	12.50	43.22	54.00	10.78
	1758.456	26.72	7.15	11.44	45.31	54.00	8.69
	2097.412	28.01	5.98	5.25	39.24	54.00	14.76

Remark : 1. Emission Level = Antenna Factor + Cable Loss + Meter Reading.
2. Measurement was up to 25GHz, but the emissions level were too low against the official limit and not report.

Date of Test : Mar. 05, 2005 Temperature : 18

EUT : RF-Modem using digital modulation w/
Pencil type antenna Humidity : 62%

Test Mode : Receiving Mode, Frequency: 2420MHz

	Emission Frequency MHz	Antenna Factor dB/m	Cable Loss dB	Meter Reading Horizontal dBµV	Emission Level Horizontal dBµV/m	Limits dBµV/m	Margin dB
Peak	1003.356	25.20	4.18	12.99	42.37	74.00	31.63
	1199.682	25.29	4.59	16.28	46.16	74.00	27.84
	1333.922	25.34	4.94	11.25	41.53	74.00	32.47
	1468.162	25.39	5.33	16.37	47.09	74.00	26.91
Average	1003.356	25.20	4.18	5.99	35.37	54.00	18.63
	1199.682	25.29	4.59	10.28	40.16	54.00	13.84
	1333.922	25.34	4.94	6.25	36.53	54.00	17.47
	1468.162	25.39	5.33	10.37	41.09	54.00	12.91

	Emission Frequency MHz	Antenna Factor dB/m	Cable Loss dB	Meter Reading Vertical dBµV	Emission Level Vertical dBµV/m	Limits dBµV/m	Margin dB
Peak	1001.678	25.20	4.18	9.67	39.05	74.00	34.95
	1196.326	25.29	4.58	11.38	41.25	74.00	32.75
	1260.090	25.31	4.70	11.07	41.08	74.00	32.92
	1461.450	25.39	5.33	15.74	46.46	74.00	27.54
Average	1001.678	25.20	4.18	3.67	33.05	54.00	20.95
	1196.326	25.29	4.58	5.38	35.25	54.00	18.75
	1260.090	25.31	4.70	5.07	35.08	54.00	18.92
	1461.450	25.39	5.33	8.74	39.46	54.00	14.54

Remark : 1. Emission Level = Antenna Factor + Cable Loss + Meter Reading.
2. Measurement was up to 25GHz, but the emissions level were too low against the official limit and not report.

Date of Test : Mar. 05, 2005 Temperature : 18

EUT : RF-Modem using digital modulation w/
Pedestal base with flexible type antenna Humidity : 62%

Test Mode : Transmitting Mode, Frequency: 2420MHz

	Emission Frequency MHz	Antenna Factor dB/m	Cable Loss dB	Meter Reading Horizontal dBµV	Emission Level Horizontal dBµV/m	Limits dBµV/m	Margin dB
Peak	1001.678	25.20	4.18	11.71	41.09	74.00	32.91
	1196.326	25.29	4.58	13.74	43.61	74.00	30.39
	1330.566	25.34	4.93	10.16	40.43	74.00	33.57
	1397.686	25.37	5.14	11.17	41.68	74.00	32.32
	1466.484	25.39	5.33	19.40	50.12	74.00	23.88
	1599.046	25.93	6.14	10.26	42.33	74.00	31.67
	1729.930	26.60	7.04	8.40	42.04	74.00	31.96
	2038.682	27.88	5.91	8.87	42.66	74.00	31.34
Average	1001.678	25.20	4.18	5.71	35.09	54.00	18.91
	1196.326	25.29	4.58	7.74	37.61	54.00	16.39
	1330.566	25.34	4.93	4.16	34.43	54.00	19.57
	1397.686	25.37	5.14	5.17	35.68	54.00	18.32
	1466.484	25.39	5.33	12.40	43.12	54.00	10.88
	1599.046	25.93	6.14	4.26	36.33	54.00	17.67
	1729.930	26.60	7.04	2.40	36.04	54.00	17.96
	2038.682	27.88	5.91	2.87	36.66	54.00	17.34

	Emission Frequency MHz	Antenna Factor dB/m	Cable Loss dB	Meter Reading Vertical dBµV	Emission Level Vertical dBµV/m	Limits dBµV/m	Margin dB
Peak	1003.356	25.20	4.18	11.09	40.47	74.00	33.53
	1115.782	25.25	4.42	10.19	39.86	74.00	34.14
	1196.326	25.29	4.58	12.74	42.61	74.00	31.39
	1266.802	25.32	4.73	11.51	41.56	74.00	32.44
	1330.566	25.34	4.93	9.64	39.91	74.00	34.09
	1464.806	25.39	5.33	18.57	49.29	74.00	24.71
	1657.776	26.24	6.56	9.45	42.25	74.00	31.75
	2038.682	27.88	5.91	8.35	42.14	74.00	31.86
Average	1003.356	25.20	4.18	5.09	34.47	54.00	19.53
	1115.782	25.25	4.42	4.19	33.86	54.00	20.14
	1196.326	25.29	4.58	6.74	36.61	54.00	17.39
	1266.802	25.32	4.73	6.51	36.56	54.00	17.44
	1330.566	25.34	4.93	4.64	34.91	54.00	19.09
	1464.806	25.39	5.33	11.57	42.29	54.00	11.71
	1657.776	26.24	6.56	3.45	36.25	54.00	17.75
	2038.682	27.88	5.91	3.35	37.14	54.00	16.86

Remark : 1. Emission Level = Antenna Factor + Cable Loss + Meter Reading.
2. Measurement was up to 25GHz, but the emissions level were too low against the official limit and not report.

Date of Test : Mar. 05, 2005 Temperature : 18

EUT : RF-Modem using digital modulation w/
Pedestal base with flexible type antenna Humidity : 62%

Test Mode : Transmitting Mode, Frequency: 2450MHz

	Emission Frequency MHz	Antenna Factor dB/m	Cable Loss dB	Meter Reading Horizontal dBµV	Emission Level Horizontal dBµV/m	Limits dBµV/m	Margin dB
Peak	1003.356	25.20	4.18	12.80	42.18	74.00	31.82
	1199.682	25.29	4.59	11.89	41.77	74.00	32.23
	1330.566	25.34	4.93	16.74	47.01	74.00	26.99
	1417.822	25.37	5.20	10.28	40.85	74.00	33.15
	1464.806	25.39	5.33	17.91	48.63	74.00	25.37
	2068.886	27.96	5.95	10.43	44.34	74.00	29.66
Average	1003.356	25.20	4.18	6.80	36.18	54.00	17.82
	1199.682	25.29	4.59	5.89	35.77	54.00	18.23
	1330.566	25.34	4.93	10.74	41.01	54.00	12.99
	1417.822	25.37	5.20	4.28	34.85	54.00	19.15
	1464.806	25.39	5.33	10.91	41.63	54.00	12.37
	2068.886	27.96	5.95	4.43	38.34	54.00	15.66

	Emission Frequency MHz	Antenna Factor dB/m	Cable Loss dB	Meter Reading Vertical dBµV	Emission Level Vertical dBµV/m	Limits dBµV/m	Margin dB
Peak	1036.916	25.22	4.26	13.37	42.85	74.00	31.15
	1073.832	25.24	4.34	12.14	41.72	74.00	32.28
	1204.716	25.29	4.59	19.51	49.39	74.00	24.61
	1263.446	25.32	4.71	12.12	42.15	74.00	31.85
	1463.128	25.39	5.33	17.39	48.11	74.00	25.89
	1716.506	26.53	6.92	17.50	50.95	74.00	23.05
	2068.886	27.96	5.95	12.58	46.49	74.00	27.51
	2609.202	29.28	6.64	11.35	47.27	74.00	26.73
Average	1036.916	25.22	4.26	8.37	37.85	54.00	16.15
	1073.832	25.24	4.34	7.14	36.72	54.00	17.28
	1204.716	25.29	4.59	12.51	42.39	54.00	11.61
	1263.446	25.32	4.71	6.12	36.15	54.00	17.85
	1463.128	25.39	5.33	11.39	42.11	54.00	11.89
	1716.506	26.53	6.92	11.50	44.95	54.00	9.05
	2068.886	27.96	5.95	6.58	40.49	54.00	13.51
	2609.202	29.28	6.64	5.35	41.27	54.00	12.73

Remark : 1. Emission Level = Antenna Factor + Cable Loss + Meter Reading.
2. Measurement was up to 25GHz, but the emissions level were too low against the official limit and not report.

Date of Test : Apr. 13, 2005 Temperature : 21
 EUT : RF-Modem using digital modulation w/ Pedestal base with flexible type antenna Humidity : 59%
 Test Mode : Transmitting Mode, Frequency: 2473MHz

	Emission Frequency MHz	Antenna Factor dB/m	Cable Loss dB	Meter Reading Horizontal dBµV	Emission Level Horizontal dBµV/m	Limits dBµV/m	Margin dB
Peak	1000.000	25.20	4.18	11.06	40.44	74.00	33.56
	1149.342	25.27	4.49	11.78	41.54	74.00	32.46
	1196.326	25.29	4.58	10.24	40.11	74.00	33.89
	1330.566	25.34	4.93	9.04	39.31	74.00	34.69
	1459.772	25.39	5.31	19.08	49.78	74.00	24.22
	1599.046	25.93	6.14	8.97	41.04	74.00	32.96
	1728.252	26.58	7.04	7.14	40.76	74.00	33.24
	1988.342	27.75	5.95	7.71	41.41	74.00	32.59
	2097.412	28.01	5.98	9.67	43.66	74.00	30.34
Average	1000.000	25.20	4.18	7.06	36.44	54.00	17.56
	1149.342	25.27	4.49	6.78	36.54	54.00	17.46
	1196.326	25.29	4.58	6.24	36.11	54.00	17.89
	1330.566	25.34	4.93	5.04	35.31	54.00	18.69
	1459.772	25.39	5.31	12.08	42.78	54.00	11.22
	1599.046	25.93	6.14	5.79	37.86	54.00	16.14
	1728.252	26.58	7.04	3.14	36.76	54.00	17.24
	1988.342	27.75	5.95	2.71	36.41	54.00	17.59
	2097.412	28.01	5.98	4.67	38.66	54.00	15.34

	Emission Frequency MHz	Antenna Factor dB/m	Cable Loss dB	Meter Reading Vertical dBµV	Emission Level Vertical dBµV/m	Limits dBµV/m	Margin dB
Peak	1090.612	25.24	4.37	9.48	39.09	74.00	34.91
	1149.342	25.27	4.49	9.09	38.85	74.00	35.15
	1288.616	25.33	4.80	9.10	39.23	74.00	34.77
	1328.886	25.34	4.93	16.23	46.50	74.00	27.50
	1464.806	25.39	5.33	13.35	44.07	74.00	29.93
	1646.030	26.17	6.45	10.32	42.94	74.00	31.06
	1761.812	26.74	7.12	17.10	50.96	74.00	23.04
	2097.412	28.01	5.98	13.04	47.03	74.00	26.97
	2563.896	29.09	6.57	8.71	44.37	74.00	29.63
Average	1090.612	25.24	4.37	3.48	33.09	54.00	20.91
	1149.342	25.27	4.49	4.09	33.85	54.00	20.15
	1288.616	25.33	4.80	4.10	34.23	54.00	19.77
	1328.888	25.34	4.93	10.23	40.50	54.00	13.50
	1464.806	25.39	5.33	8.35	39.07	54.00	14.93
	1646.030	26.17	6.45	5.32	37.94	54.00	16.06
	1761.812	26.74	7.12	11.10	44.96	54.00	9.04
	2097.412	28.01	5.98	8.04	42.03	54.00	11.97
	2563.896	29.09	6.57	4.71	40.37	54.00	13.63

Remark : 1. Emission Level = Antenna Factor + Cable Loss + Meter Reading.
 2. Measurement was up to 25GHz, but the emissions level were too low against the official limit and not report.

Date of Test : Mar. 05, 2005 Temperature : 18

EUT : RF-Modem using digital modulation w/
Pedestal base with flexible type antenna Humidity : 62%

Test Mode : Receiving Mode, Frequency: 2420MHz

	Emission Frequency MHz	Antenna Factor dB/m	Cable Loss dB	Meter Reading Horizontal dBµV	Emission Level Horizontal dBµV/m	Limits dBµV/m	Margin dB
Peak	1003.356	25.20	4.18	13.29	42.67	74.00	31.33
	1065.442	25.23	4.32	13.57	43.12	74.00	30.88
	1199.682	25.29	4.59	12.12	42.00	74.00	32.00
	1468.162	25.39	5.33	17.59	48.31	74.00	25.69
	1602.402	25.95	6.14	12.88	44.97	74.00	29.03
	1728.252	26.58	7.04	9.41	43.03	74.00	30.97
	1988.342	27.75	5.95	7.96	41.66	74.00	32.34
Average	1003.356	25.20	4.18	7.29	36.67	54.00	17.33
	1065.442	25.23	4.32	7.57	37.12	54.00	16.88
	1199.682	25.29	4.59	6.12	36.00	54.00	18.00
	1468.162	25.39	5.33	11.59	42.31	54.00	11.69
	1602.402	25.95	6.14	6.88	38.97	54.00	15.03
	1728.252	26.58	7.04	4.41	38.03	54.00	15.97
	1988.342	27.75	5.95	2.96	36.66	54.00	17.34

	Emission Frequency MHz	Antenna Factor dB/m	Cable Loss dB	Meter Reading Vertical dBµV	Emission Level Vertical dBµV/m	Limits dBµV/m	Margin dB
Peak	1003.356	25.20	4.18	11.59	40.97	74.00	33.03
	1048.662	25.22	4.28	14.67	44.17	74.00	29.83
	1196.326	25.29	4.58	11.93	41.80	74.00	32.20
	1263.446	25.32	4.71	11.93	41.96	74.00	32.04
	1330.566	25.34	4.93	11.76	42.03	74.00	31.97
	1461.450	25.39	5.33	14.33	45.05	74.00	28.95
	Average	1003.356	25.20	4.18	5.59	34.97	54.00
1048.662		25.22	4.28	8.67	38.17	54.00	15.83
1196.326		25.29	4.58	5.93	35.80	54.00	18.20
1263.446		25.32	4.71	5.93	35.96	54.00	18.04
1330.566		25.34	4.93	5.76	36.03	54.00	17.97
1461.450		25.39	5.33	8.33	39.05	54.00	14.95

Remark : 1. Emission Level = Antenna Factor + Cable Loss + Meter Reading.
2. Measurement was up to 25GHz, but the emissions level were too low against the official limit and not report.

Date of Test : Mar. 05, 2005 Temperature : 18

EUT : RF-Modem using digital modulation w/
Pedestal base with rigid type antenna Humidity : 62%

Test Mode : Transmitting Mode, Frequency: 2420MHz

	Emission Frequency MHz	Antenna Factor dB/m	Cable Loss dB	Meter Reading Horizontal dBµV	Emission Level Horizontal dBµV/m	Limits dBµV/m	Margin dB
Peak	1001.678	25.20	4.18	13.74	43.12	74.00	30.88
	1201.360	25.29	4.59	12.32	42.20	74.00	31.80
	1330.566	25.34	4.93	10.16	40.43	74.00	33.57
	1401.042	25.37	5.14	12.27	42.78	74.00	31.22
	1466.484	25.39	5.33	18.51	49.23	74.00	24.77
	1599.046	25.93	6.14	8.75	40.82	74.00	33.18
	1733.286	26.60	7.07	8.23	41.90	74.00	32.10
	2038.682	27.88	5.91	8.66	42.45	74.00	31.55
Average	1001.678	25.20	4.18	7.74	37.12	54.00	16.88
	1201.360	25.29	4.59	6.32	36.20	54.00	17.80
	1330.566	25.34	4.93	4.16	34.43	54.00	19.57
	1401.042	25.37	5.14	6.27	36.78	54.00	17.22
	1466.484	25.39	5.33	11.51	42.23	54.00	11.77
	1599.046	25.93	6.14	2.75	34.82	54.00	19.18
	1733.286	26.60	7.07	2.23	35.90	54.00	18.10
	2038.682	27.88	5.91	2.66	36.45	54.00	17.55

	Emission Frequency MHz	Antenna Factor dB/m	Cable Loss dB	Meter Reading Vertical dBµV	Emission Level Vertical dBµV/m	Limits dBµV/m	Margin dB
Peak	1199.682	25.29	4.59	18.18	48.06	74.00	25.94
	1266.802	25.32	4.73	10.83	40.88	74.00	33.12
	1330.566	25.34	4.93	11.95	42.22	74.00	31.78
	1468.162	25.39	5.33	17.66	48.38	74.00	25.62
	1657.776	26.24	6.56	9.15	41.95	74.00	32.05
	1775.236	26.82	7.04	8.83	42.69	74.00	31.31
	1867.526	27.22	6.53	8.52	42.27	74.00	31.73
	2038.682	27.88	5.91	9.24	43.03	74.00	30.97
Average	1199.682	25.29	4.59	12.18	42.06	54.00	11.94
	1266.802	25.32	4.73	4.83	34.88	54.00	19.12
	1330.566	25.34	4.93	5.95	36.22	54.00	17.78
	1468.162	25.39	5.33	10.66	41.38	54.00	12.62
	1657.776	26.24	6.56	3.15	35.95	54.00	18.05
	1775.236	26.82	7.04	2.83	36.69	54.00	17.31
	1867.526	27.22	6.53	2.52	36.27	54.00	17.73
	2038.682	27.88	5.91	3.24	37.03	54.00	16.97

Remark : 1. Emission Level = Antenna Factor + Cable Loss + Meter Reading.
2. Measurement was up to 25GHz, but the emissions level were too low against the official limit and not report.

Date of Test : Mar. 05, 2005 Temperature : 18

EUT : RF-Modem using digital modulation w/
Pedestal base with rigid type antenna Humidity : 62%

Test Mode : Transmitting Mode, Frequency: 2450MHz

	Emission Frequency MHz	Antenna Factor dB/m	Cable Loss dB	Meter Reading Horizontal dBµV	Emission Level Horizontal dBµV/m	Limits dBµV/m	Margin dB
Peak	1003.356	25.20	4.18	4.79	34.17	74.00	39.83
	1199.682	25.29	4.59	12.69	42.57	74.00	31.43
	1325.532	25.34	4.91	12.63	42.88	74.00	31.12
	1406.076	25.37	5.16	11.27	41.80	74.00	32.20
	1468.162	25.39	5.33	17.97	48.69	74.00	25.31
	1728.252	26.58	7.04	8.91	42.53	74.00	31.47
	2068.886	27.96	5.95	12.02	45.93	74.00	28.07
Average	1003.356	25.20	4.18	8.79	38.17	54.00	15.83
	1199.682	25.29	4.59	6.69	36.57	54.00	17.43
	1325.532	25.34	4.91	6.63	36.88	54.00	17.12
	1406.076	25.37	5.16	5.27	35.80	54.00	18.20
	1468.162	25.39	5.33	10.97	41.69	54.00	12.31
	1728.252	26.58	7.04	3.91	37.53	54.00	16.47
	2068.886	27.96	5.95	6.02	39.93	54.00	14.07

	Emission Frequency MHz	Antenna Factor dB/m	Cable Loss dB	Meter Reading Vertical dBµV	Emission Level Vertical dBµV/m	Limits dBµV/m	Margin dB
Peak	1011.746	25.21	4.21	10.23	39.65	74.00	34.35
	1204.716	25.29	4.59	11.19	41.07	74.00	32.93
	1325.532	25.34	4.91	9.99	40.24	74.00	33.76
	1464.806	25.39	5.33	16.79	47.51	74.00	26.49
	1716.506	26.53	6.92	9.43	42.88	74.00	31.12
	2068.886	27.96	5.95	12.14	46.05	74.00	27.95
	Average	1011.746	25.21	4.21	4.24	33.66	54.00
1204.716		25.29	4.59	5.19	35.07	54.00	18.93
1325.532		25.34	4.91	4.98	35.23	54.00	18.77
1464.806		25.39	5.33	10.80	41.52	54.00	12.48
1716.506		26.53	6.92	3.43	36.88	54.00	17.12
2068.886		27.96	5.95	7.14	41.05	54.00	12.95

Remark : 1. Emission Level = Antenna Factor + Cable Loss + Meter Reading.
2. Measurement was up to 25GHz, but the emissions level were too low against the official limit and not report.

Date of Test : Apr. 13, 2005 Temperature : 21

EUT : RF-Modem using digital modulation w/
Pedestal base with rigid type antenna Humidity : 59%

Test Mode : Transmitting Mode, Frequency: 2473MHz

	Emission Frequency MHz	Antenna Factor dB/m	Cable Loss dB	Meter Reading Horizontal dBµV	Emission Level Horizontal dBµV/m	Limits dBµV/m	Margin dB
Peak	1001.678	25.20	4.18	10.60	39.98	74.00	34.02
	1196.326	25.29	4.58	10.79	40.66	74.00	33.34
	1333.922	25.34	4.94	10.91	41.19	74.00	32.81
	1466.484	25.39	5.33	14.57	45.29	74.00	28.71
	1726.574	26.58	7.00	8.85	42.43	74.00	31.57
	2097.412	28.01	5.98	9.35	43.34	74.00	30.66
Average	1001.678	25.20	4.18	5.60	34.98	54.00	19.02
	1196.326	25.29	4.58	6.79	36.66	54.00	17.34
	1333.922	25.34	4.94	5.91	36.19	54.00	17.81
	1466.484	25.39	5.33	8.57	39.29	54.00	14.71
	1726.574	26.58	7.00	4.85	38.43	54.00	15.57
	2097.412	28.01	5.98	5.35	39.34	54.00	14.66

	Emission Frequency MHz	Antenna Factor dB/m	Cable Loss dB	Meter Reading Vertical dBµV	Emission Level Vertical dBµV/m	Limits dBµV/m	Margin dB
Peak	1006.712	25.20	4.19	18.69	48.08	74.00	25.92
	1028.526	25.21	4.24	14.40	43.85	74.00	30.15
	1149.342	25.27	4.49	13.18	42.94	74.00	31.06
	1187.936	25.29	4.56	12.67	42.52	74.00	31.48
	1258.412	25.31	4.70	9.75	39.76	74.00	34.24
	1325.532	25.34	4.91	8.96	39.21	74.00	34.79
	1463.128	25.39	5.33	17.62	48.34	74.00	25.66
	1719.862	26.55	6.96	8.54	42.05	74.00	31.95
	1761.812	26.74	7.12	13.25	47.11	74.00	26.89
	2097.412	28.01	5.98	11.99	45.98	74.00	28.02
Average	1006.712	25.20	4.19	12.69	42.08	54.00	11.92
	1028.526	25.21	4.24	9.40	38.85	54.00	15.15
	1149.342	25.27	4.49	7.18	36.94	54.00	17.06
	1187.936	25.29	4.56	7.67	37.52	54.00	16.48
	1258.412	25.31	4.70	4.75	34.76	54.00	19.24
	1325.532	25.34	4.91	3.96	34.21	54.00	19.79
	1463.128	25.39	5.33	11.62	42.34	54.00	11.66
	1719.862	26.55	6.96	4.54	38.05	54.00	15.95
	1761.812	26.74	7.12	7.25	41.11	54.00	12.89
	2097.412	28.01	5.98	6.99	40.98	54.00	13.02

Remark : 1. Emission Level = Antenna Factor + Cable Loss + Meter Reading.
2. Measurement was up to 25GHz, but the emissions level were too low against the official limit and not report.

Date of Test : Mar. 05, 2005 Temperature : 18

EUT : RF-Modem using digital modulation w/
Pedestal base with rigid type antenna Humidity : 62%

Test Mode : Receiving Mode, Frequency: 2420MHz

	Emission Frequency MHz	Antenna Factor dB/m	Cable Loss dB	Meter Reading Horizontal dBµV	Emission Level Horizontal dBµV/m	Limits dBµV/m	Margin dB
Peak	1003.356	25.20	4.18	13.66	43.04	74.00	30.96
	1199.682	25.29	4.59	13.53	43.41	74.00	30.59
	1466.484	25.39	5.33	17.63	48.35	74.00	25.65
	1599.046	25.93	6.14	8.75	40.82	74.00	33.18
Average	1003.356	25.20	4.18	7.66	37.04	54.00	16.96
	1199.682	25.29	4.59	7.53	37.41	54.00	16.59
	1466.484	25.39	5.33	11.63	42.35	54.00	11.65
	1599.046	25.93	6.14	3.75	35.82	54.00	18.18

	Emission Frequency MHz	Antenna Factor dB/m	Cable Loss dB	Meter Reading Vertical dBµV	Emission Level Vertical dBµV/m	Limits dBµV/m	Margin dB
Peak	1006.712	25.20	4.19	13.31	42.70	74.00	31.30
	1036.916	25.22	4.26	14.66	44.14	74.00	29.86
	1095.646	25.25	4.38	15.84	45.47	74.00	28.53
	1112.426	25.25	4.42	11.47	41.14	74.00	32.86
	1263.446	25.32	4.71	11.43	41.46	74.00	32.54
	1330.566	25.34	4.93	12.09	42.36	74.00	31.64
	1464.806	25.39	5.33	16.11	46.83	74.00	27.17
	Average	1006.712	25.20	4.19	7.31	36.70	54.00
1036.916		25.22	4.26	7.66	37.14	54.00	16.86
1095.646		25.25	4.38	9.84	39.47	54.00	14.53
1112.426		25.25	4.42	5.47	35.14	54.00	18.86
1263.446		25.32	4.71	5.43	35.46	54.00	18.54
1330.566		25.34	4.93	6.09	36.36	54.00	17.64
1464.806		25.39	5.33	10.11	40.83	54.00	13.17

Remark : 1. Emission Level = Antenna Factor + Cable Loss + Meter Reading.
2. Measurement was up to 25GHz, but the emissions level were too low against the official limit and not report.

Date of Test : Mar. 05, 2005 Temperature : 18

EUT : RF-Modem using digital modulation w/
Flat type, two CoAx cables Humidity : 62%

Test Mode : Transmitting Mode, Frequency: 2420MHz

	Emission Frequency MHz	Antenna Factor dB/m	Cable Loss dB	Meter Reading Horizontal dBµV	Emission Level Horizontal dBµV/m	Limits dBµV/m	Margin dB
Peak	1000.000	25.20	4.18	11.48	40.86	74.00	33.14
	1201.360	25.29	4.59	11.16	41.04	74.00	32.96
	1224.852	25.30	4.63	9.52	39.45	74.00	34.55
	1330.566	25.34	4.93	12.50	42.77	74.00	31.23
	1468.162	25.39	5.33	19.02	49.74	74.00	24.26
	1599.046	25.93	6.14	8.86	40.93	74.00	33.07
Average	1000.000	25.20	4.18	6.48	35.86	54.00	18.14
	1201.360	25.29	4.59	6.16	36.04	54.00	17.96
	1224.852	25.30	4.63	4.52	34.45	54.00	19.55
	1330.566	25.34	4.93	7.50	37.77	54.00	16.23
	1468.162	25.39	5.33	13.02	43.74	54.00	10.26
	1599.046	25.93	6.14	3.86	35.93	54.00	18.07

	Emission Frequency MHz	Antenna Factor dB/m	Cable Loss dB	Meter Reading Vertical dBµV	Emission Level Vertical dBµV/m	Limits dBµV/m	Margin dB
Peak	1149.342	25.27	4.49	14.67	44.43	74.00	29.57
	1199.682	25.29	4.59	14.29	44.17	74.00	29.83
	1263.446	25.32	4.71	11.61	41.64	74.00	32.36
	1330.566	25.34	4.93	12.09	42.36	74.00	31.64
	1463.128	25.39	5.33	16.16	46.88	74.00	27.12
Average	1149.342	25.27	4.49	9.67	39.43	54.00	14.57
	1199.682	25.29	4.59	9.29	39.17	54.00	14.83
	1263.446	25.32	4.71	6.61	36.64	54.00	17.36
	1330.566	25.34	4.93	7.09	37.36	54.00	16.64
	1463.128	25.39	5.33	11.16	41.88	54.00	12.12

Remark : 1. Emission Level = Antenna Factor + Cable Loss + Meter Reading.
2. Measurement was up to 25GHz, but the emissions level were too low against the official limit and not report.

Date of Test : Mar. 05, 2005 Temperature : 18

EUT : RF-Modem using digital modulation w/
Flat type, two CoAx cables Humidity : 62%

Test Mode : Transmitting Mode, Frequency: 2450MHz

	Emission Frequency MHz	Antenna Factor dB/m	Cable Loss dB	Meter Reading Horizontal dBµV	Emission Level Horizontal dBµV/m	Limits dBµV/m	Margin dB
Peak	1001.678	25.20	4.18	13.32	42.70	74.00	31.30
	1199.682	25.29	4.59	15.48	45.36	74.00	28.64
	1466.484	25.39	5.33	18.05	48.77	74.00	25.23
	1724.896	26.58	7.00	9.81	43.39	74.00	30.61
	2068.886	27.96	5.95	11.09	45.00	74.00	29.00
Average	1001.678	25.20	4.18	6.32	35.70	54.00	18.30
	1199.682	25.29	4.59	9.48	39.36	54.00	14.64
	1466.484	25.39	5.33	12.05	42.77	54.00	11.23
	1724.896	26.58	7.00	4.81	38.39	54.00	15.61
	2068.886	27.96	5.95	5.09	39.00	54.00	15.00

	Emission Frequency MHz	Antenna Factor dB/m	Cable Loss dB	Meter Reading Vertical dBµV	Emission Level Vertical dBµV/m	Limits dBµV/m	Margin dB
Peak	1028.526	25.21	4.24	12.82	42.27	74.00	31.73
	1104.036	25.25	4.40	14.61	44.26	74.00	29.74
	1196.326	25.29	4.58	12.79	42.66	74.00	31.34
	1265.124	25.32	4.73	11.39	41.44	74.00	32.56
	1333.922	25.34	4.94	11.37	41.65	74.00	32.35
	1459.772	25.39	5.31	17.96	48.66	74.00	25.34
Average	1028.526	25.21	4.24	7.82	37.27	54.00	16.73
	1104.036	25.25	4.40	9.61	39.26	54.00	14.74
	1196.326	25.29	4.58	6.79	36.66	54.00	17.34
	1265.124	25.32	4.73	5.39	35.44	54.00	18.56
	1333.922	25.34	4.94	5.37	35.65	54.00	18.35
	1459.772	25.39	5.31	11.96	42.66	54.00	11.34

Remark : 1. Emission Level = Antenna Factor + Cable Loss + Meter Reading.
2. Measurement was up to 25GHz, but the emissions level were too low against the official limit and not report.

Date of Test : Apr. 13, 2005 Temperature : 21

EUT : RF-Modem using digital modulation w/
Flat type, two CoAx cables Humidity : 59%

Test Mode : Transmitting Mode, Frequency: 2473MHz

	Emission Frequency MHz	Antenna Factor dB/m	Cable Loss dB	Meter Reading Horizontal dBµV	Emission Level Horizontal dBµV/m	Limits dBµV/m	Margin dB
Peak	1001.678	25.20	4.18	11.80	41.18	74.00	32.82
	1199.682	25.29	4.59	13.64	43.52	74.00	30.48
	1328.888	25.34	4.93	13.88	44.15	74.00	29.85
	1459.772	25.39	5.31	16.45	47.15	74.00	26.85
	1724.896	26.58	7.00	10.05	43.63	74.00	30.37
	1995.054	27.78	5.89	9.64	43.31	74.00	30.69
	2097.412	28.01	5.98	9.78	43.77	74.00	30.23
Average	1001.678	25.20	4.18	6.80	36.18	54.00	17.82
	1199.682	25.29	4.59	7.64	37.52	54.00	16.48
	1328.888	25.34	4.93	7.88	38.15	54.00	15.85
	1459.772	25.39	5.31	9.45	40.15	54.00	13.85
	1724.896	26.58	7.00	5.05	38.63	54.00	15.37
	1995.054	27.78	5.89	4.64	38.31	54.00	15.69
	2097.412	28.01	5.98	3.78	37.77	54.00	16.23

	Emission Frequency MHz	Antenna Factor dB/m	Cable Loss dB	Meter Reading Vertical dBµV	Emission Level Vertical dBµV/m	Limits dBµV/m	Margin dB
Peak	1003.356	25.20	4.18	13.37	42.75	74.00	31.25
	1031.882	25.22	4.24	12.12	41.58	74.00	32.42
	1062.086	25.23	4.31	11.89	41.43	74.00	32.57
	1260.090	25.31	4.70	10.64	40.65	74.00	33.35
	1333.922	25.34	4.94	11.00	41.28	74.00	32.72
	1464.806	25.39	5.33	14.15	44.87	74.00	29.13
	1699.726	26.46	6.83	8.62	41.91	74.00	32.09
	2097.412	28.01	5.98	8.34	42.33	74.00	31.67
	2572.286	29.12	6.58	8.69	44.39	74.00	29.61
Average	1003.356	25.20	4.18	7.37	36.75	54.00	17.25
	1031.882	25.22	4.24	7.12	36.58	54.00	17.42
	1062.086	25.23	4.31	5.89	35.43	54.00	18.57
	1260.090	25.31	4.70	5.64	35.65	54.00	18.35
	1333.922	25.34	4.94	5.00	35.28	54.00	18.72
	1464.806	25.39	5.33	9.15	39.87	54.00	14.13
	1699.726	26.46	6.83	4.62	37.91	54.00	16.09
	2097.412	28.01	5.98	4.34	38.33	54.00	15.67
	2572.286	29.12	6.58	3.69	39.39	54.00	14.61

Remark : 1. Emission Level = Antenna Factor + Cable Loss + Meter Reading.
2. Measurement was up to 25GHz, but the emissions level were too low against the official limit and not report.

Date of Test : Mar. 05, 2005 Temperature : 18

EUT : RF-Modem using digital modulation w/
Flat type, two CoAx cables Humidity : 62%

Test Mode : Receiving Mode, Frequency: 2420MHz

	Emission Frequency MHz	Antenna Factor dB/m	Cable Loss dB	Meter Reading Horizontal dBµV	Emission Level Horizontal dBµV/m	Limits dBµV/m	Margin dB
Peak	1003.356	25.20	4.18	11.41	40.79	74.00	33.21
	1198.004	25.29	4.58	12.72	42.59	74.00	31.41
	1333.922	25.34	4.94	12.09	42.37	74.00	31.63
	1466.484	25.39	5.33	17.27	47.99	74.00	26.01
Average	1003.356	25.20	4.18	6.41	35.79	54.00	18.21
	1198.004	25.29	4.58	7.72	37.59	54.00	16.41
	1333.922	25.34	4.94	6.09	36.37	54.00	17.63
	1466.484	25.39	5.33	10.27	40.99	54.00	13.01

	Emission Frequency MHz	Antenna Factor dB/m	Cable Loss dB	Meter Reading Vertical dBµV	Emission Level Vertical dBµV/m	Limits dBµV/m	Margin dB
Peak	1063.764	25.23	4.32	15.51	45.06	74.00	28.94
	1196.326	25.29	4.58	12.82	42.69	74.00	31.31
	1266.802	25.32	4.73	11.53	41.58	74.00	32.42
	1468.162	25.39	5.33	17.30	48.02	74.00	25.98
Average	1063.764	25.23	4.32	8.51	38.06	54.00	15.94
	1196.326	25.29	4.58	6.82	36.69	54.00	17.31
	1266.802	25.32	4.73	5.53	35.58	54.00	18.42
	1468.162	25.39	5.33	10.30	41.02	54.00	12.98

Remark : 1. Emission Level = Antenna Factor + Cable Loss + Meter Reading.
2. Measurement was up to 25GHz, but the emissions level were too low against the official limit and not report.

Date of Test : Mar. 05, 2005 Temperature : 18

EUT : RF-Modem using digital modulation w/
Flat type, single CoAx cable Humidity : 62%

Test Mode : Transmitting Mode, Frequency: 2420MHz

	Emission Frequency MHz	Antenna Factor dB/m	Cable Loss dB	Meter Reading Horizontal dBµV	Emission Level Horizontal dBµV/m	Limits dBµV/m	Margin dB
Peak	1001.678	25.20	4.18	15.99	45.37	74.00	28.63
	1196.326	25.29	4.58	17.51	47.38	74.00	26.62
	1328.888	25.34	4.93	11.50	41.77	74.00	32.23
	1464.806	25.39	5.33	19.12	49.84	74.00	24.16
	1602.402	25.95	6.14	11.12	43.21	74.00	30.79
	1726.574	26.58	7.00	8.52	42.10	74.00	31.90
Average	1001.678	25.20	4.18	9.99	39.37	54.00	14.63
	1196.326	25.29	4.58	11.51	41.38	54.00	12.62
	1328.888	25.34	4.93	6.50	36.77	54.00	17.23
	1464.806	25.39	5.33	13.12	43.84	54.00	10.16
	1602.402	25.95	6.14	6.12	38.21	54.00	15.79
	1726.574	26.58	7.00	3.52	37.10	54.00	16.90
	Emission Frequency MHz	Antenna Factor dB/m	Cable Loss dB	Meter Reading Vertical dBµV	Emission Level Vertical dBµV/m	Limits dBµV/m	Margin dB
Peak	1003.356	25.20	4.18	11.64	41.02	74.00	32.98
	1199.682	25.29	4.59	15.39	45.27	74.00	28.73
	1263.446	25.32	4.71	12.19	42.22	74.00	31.78
	1330.566	25.34	4.93	11.58	41.85	74.00	32.15
	1464.806	25.39	5.33	18.43	49.15	74.00	24.85
Average	1003.356	25.20	4.18	5.64	35.02	54.00	18.98
	1199.682	25.29	4.59	9.39	39.27	54.00	14.73
	1263.446	25.32	4.71	6.19	36.22	54.00	17.78
	1330.566	25.34	4.93	5.58	35.85	54.00	18.15
	1464.806	25.39	5.33	12.43	43.15	54.00	10.85

Remark : 1. Emission Level = Antenna Factor + Cable Loss + Meter Reading.
2. Measurement was up to 25GHz, but the emissions level were too low against the official limit and not report.

Date of Test : Mar. 05, 2005 Temperature : 18

EUT : RF-Modem using digital modulation w/
Flat type, single CoAx cable Humidity : 62%

Test Mode : Transmitting Mode, Frequency: 2450MHz

	Emission Frequency MHz	Antenna Factor dB/m	Cable Loss dB	Meter Reading Horizontal dBµV	Emission Level Horizontal dBµV/m	Limits dBµV/m	Margin dB
Peak	1001.678	25.20	4.18	14.16	43.54	74.00	30.46
	1065.442	25.23	4.32	11.04	40.59	74.00	33.41
	1199.682	25.29	4.59	11.47	41.35	74.00	32.65
	1325.532	25.34	4.91	14.92	45.17	74.00	28.83
	1466.484	25.39	5.33	19.72	50.44	74.00	23.56
	2068.886	27.96	5.95	10.75	44.66	74.00	29.34
Average	1001.678	25.20	4.18	8.16	37.54	54.00	16.46
	1065.442	25.23	4.32	6.04	35.59	54.00	18.41
	1199.682	25.29	4.59	5.47	35.35	54.00	18.65
	1325.532	25.34	4.91	8.92	39.17	54.00	14.83
	1466.484	25.39	5.33	12.72	43.44	54.00	10.56
	2068.886	27.96	5.95	6.75	40.66	54.00	13.34

	Emission Frequency MHz	Antenna Factor dB/m	Cable Loss dB	Meter Reading Vertical dBµV	Emission Level Vertical dBµV/m	Limits dBµV/m	Margin dB
Peak	1031.882	25.22	4.24	16.22	45.68	74.00	28.32
	1040.272	25.22	4.26	19.84	49.32	74.00	24.68
	1073.832	25.24	4.34	18.09	47.67	74.00	26.33
	1199.682	25.29	4.59	11.96	41.84	74.00	32.16
	1263.446	25.32	4.71	12.14	42.17	74.00	31.83
	1326.888	25.34	4.93	11.36	41.63	74.00	32.37
	1466.484	25.39	5.33	16.97	47.69	74.00	26.31
	2068.886	27.96	5.95	8.66	42.57	74.00	31.43
Average	1031.882	25.22	4.24	10.22	39.68	54.00	14.32
	1040.272	25.22	4.26	13.84	43.32	54.00	10.68
	1073.832	25.24	4.34	12.09	41.67	54.00	12.33
	1199.682	25.29	4.59	5.96	35.84	54.00	18.16
	1263.446	25.32	4.71	6.14	36.17	54.00	17.83
	1326.888	25.34	4.93	6.36	36.63	54.00	17.37
	1466.484	25.39	5.33	10.97	41.69	54.00	12.31
	2068.886	27.96	5.95	3.66	37.57	54.00	16.43

Remark : 1. Emission Level = Antenna Factor + Cable Loss + Meter Reading.
 2. Measurement was up to 25GHz, but the emissions level were too low against the official limit and not report.

Date of Test : Apr. 13, 2005 Temperature : 21

EUT : RF-Modem using digital modulation w/
Flat type, single CoAx cable Humidity : 59%

Test Mode : Transmitting Mode, Frequency: 2473MHz

	Emission Frequency MHz	Antenna Factor dB/m	Cable Loss dB	Meter Reading Horizontal dBµV	Emission Level Horizontal dBµV/m	Limits dBµV/m	Margin dB
Peak	1001.678	25.20	4.18	11.06	40.44	74.00	33.56
	1199.682	25.29	4.59	14.22	44.10	74.00	29.90
	1330.566	25.34	4.93	14.94	45.21	74.00	28.79
	1468.162	25.39	5.33	16.97	47.69	74.00	26.31
	1726.574	26.58	7.00	10.11	43.69	74.00	30.31
	2097.412	28.01	5.98	10.53	44.52	74.00	29.48
Average	1001.678	25.20	4.18	7.06	36.44	54.00	17.56
	1199.682	25.29	4.59	8.22	38.10	54.00	15.90
	1330.566	25.34	4.93	8.94	39.21	54.00	14.79
	1468.162	25.39	5.33	10.97	41.69	54.00	12.31
	1726.574	26.58	7.00	5.11	38.69	54.00	15.31
	2097.412	28.01	5.98	6.53	40.52	54.00	13.48

	Emission Frequency MHz	Antenna Factor dB/m	Cable Loss dB	Meter Reading Vertical dBµV	Emission Level Vertical dBµV/m	Limits dBµV/m	Margin dB
Peak	1048.662	25.22	4.28	15.98	45.48	74.00	28.52
	1157.732	25.27	4.50	12.39	42.16	74.00	31.84
	1203.038	25.29	4.59	16.14	46.02	74.00	27.98
	1263.446	25.32	4.71	11.89	41.92	74.00	32.08
	1327.210	25.34	4.91	12.30	42.55	74.00	31.45
	1599.046	25.93	6.14	9.43	41.50	74.00	32.50
	2097.412	28.01	5.98	9.15	43.14	74.00	30.86
Average	1048.662	25.22	4.28	9.98	39.48	54.00	14.52
	1157.732	25.27	4.50	6.39	36.16	54.00	17.84
	1203.038	25.29	4.59	8.14	38.02	54.00	15.98
	1263.446	25.32	4.71	6.89	36.92	54.00	17.08
	1464.806	25.39	5.33	9.22	39.94	54.00	14.06
	1599.046	25.93	6.14	5.43	37.50	54.00	16.50
	2097.412	28.01	5.98	3.15	37.14	54.00	16.86

Remark : 1. Emission Level = Antenna Factor + Cable Loss + Meter Reading.
2. Measurement was up to 25GHz, but the emissions level were too low against the official limit and not report.

Date of Test : Mar. 05, 2005 Temperature : 18

EUT : RF-Modem using digital modulation w/
Flat type, single CoAx cable Humidity : 62%

Test Mode : Receiving Mode, Frequency: 2420MHz

	Emission Frequency MHz	Antenna Factor dB/m	Cable Loss dB	Meter Reading Horizontal dBµV	Emission Level Horizontal dBµV/m	Limits dBµV/m	Margin dB
Peak	1001.678	25.20	4.18	12.11	41.49	74.00	32.51
	1196.326	25.29	4.58	12.53	42.40	74.00	31.60
	1333.922	25.34	4.94	11.44	41.72	74.00	32.28
	1468.162	25.39	5.33	18.21	48.93	74.00	25.07
	1726.574	26.58	7.00	8.22	41.80	74.00	32.20
Average	1001.678	25.20	4.18	7.11	36.49	54.00	17.51
	1196.326	25.29	4.58	7.53	37.40	54.00	16.60
	1333.922	25.34	4.94	6.44	36.72	54.00	17.28
	1468.162	25.39	5.33	13.21	43.93	54.00	10.07
	1726.574	26.58	7.00	3.22	36.80	54.00	17.20

	Emission Frequency MHz	Antenna Factor dB/m	Cable Loss dB	Meter Reading Vertical dBµV	Emission Level Vertical dBµV/m	Limits dBµV/m	Margin dB
Peak	1031.882	25.22	4.24	10.42	39.88	74.00	34.12
	1196.326	25.29	4.58	11.65	41.52	74.00	32.48
	1266.802	25.32	4.73	10.69	40.74	74.00	33.26
	1333.922	25.34	4.94	10.92	41.20	74.00	32.80
	1464.806	25.39	5.33	18.25	48.97	74.00	25.03
	1971.562	27.68	5.99	8.42	42.09	74.00	31.91
Average	1031.882	25.22	4.24	5.42	34.88	54.00	19.12
	1196.326	25.29	4.58	6.65	36.52	54.00	17.48
	1266.802	25.32	4.73	4.69	34.74	54.00	19.26
	1333.922	25.34	4.94	3.92	34.20	54.00	19.80
	1464.806	25.39	5.33	11.25	41.97	54.00	12.03
	1971.562	27.68	5.99	3.42	37.09	54.00	16.91

Remark : 1. Emission Level = Antenna Factor + Cable Loss + Meter Reading.
2. Measurement was up to 25GHz, but the emissions level were too low against the official limit and not report.

3.6.3. Restricted Bands Measurement Results

Date of Test : Mar. 05, 2005 Temperature : 18
 EUT : RF-Modem using digital modulation with Pencil type antenna Humidity : 62%
 Test Mode : Transmitting Mode, Frequency: 2420MHz

	Emission Frequency MHz	Antenna Factor dB/m	Cable Loss dB	Meter Reading Horizontal dBμV	Emission Level Horizontal dBμV/m	Limits dBμV/m	Margin dB
Peak *	2370.480	28.57	6.31	8.68	43.56	74.00	30.44
	2399.900	28.62	6.35	5.18	40.15	74.00	33.85
	2420.400	28.66	6.37	55.14	90.17	74.00	-16.17
Average *	2352.240	28.53	6.29	5.77	40.59	54.00	13.41
	2399.900	28.62	6.35	3.37	38.34	54.00	15.66
	2420.040	28.66	6.37	47.86	82.89	54.00	-28.89

- Remark : 1. Emission Level = Antenna Factor + Cable Loss + Meter Reading.
 2. Low frequency section (spurious in the restricted band 2310-2390MHz).
 3. ‘*’ The field strength of emission appearing within Part 15.205(a) shall not exceed the limits shown in section 15.209.

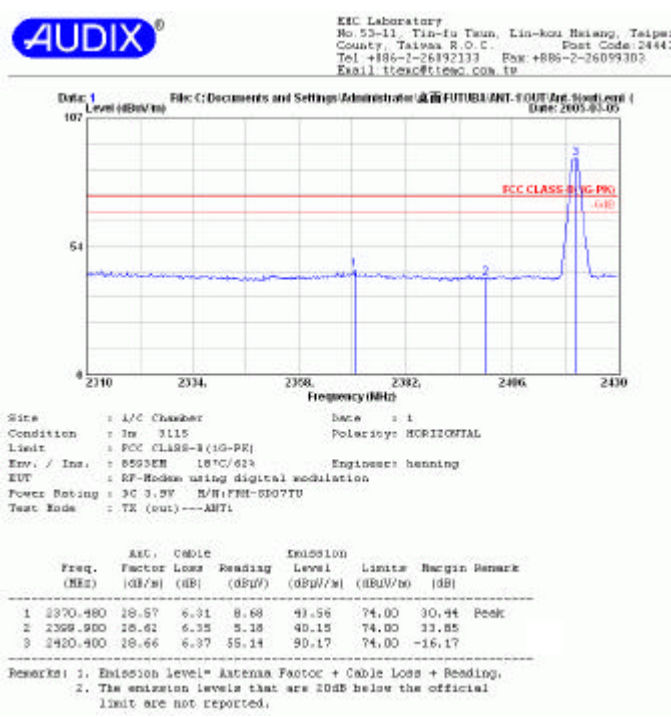

Date of Test : Mar. 05, 2005 Temperature : 18
 EUT : RF-Modem using digital modulation with Pencil type antenna Humidity : 62%
 Test Mode : Transmitting Mode, Frequency: 2420MHz

	Emission Frequency MHz	Antenna Factor dB/m	Cable Loss dB	Meter Reading Vertical dBμV	Emission Level Vertical dBμV/m	Limits dBμV/m	Margin dB
Peak *	2330.640	28.49	6.26	7.80	42.55	74.00	31.45
	2399.900	28.62	6.35	5.02	39.99	74.00	34.01
	2420.400	28.66	6.37	62.53	97.56	74.00	-23.56
Average *	2323.440	28.48	6.25	5.94	40.67	54.00	13.33
	2399.900	28.62	6.35	3.53	38.50	54.00	15.50
	2420.400	28.66	6.37	62.05	97.08	54.00	-43.08

- Remark : 1. Emission Level = Antenna Factor + Cable Loss + Meter Reading.
 2. Low frequency section (spurious in the restricted band 2310-2390MHz).
 3. ‘*’ The field strength of emission appearing within Part 15.205(a) shall not exceed the limits shown in section 15.209.

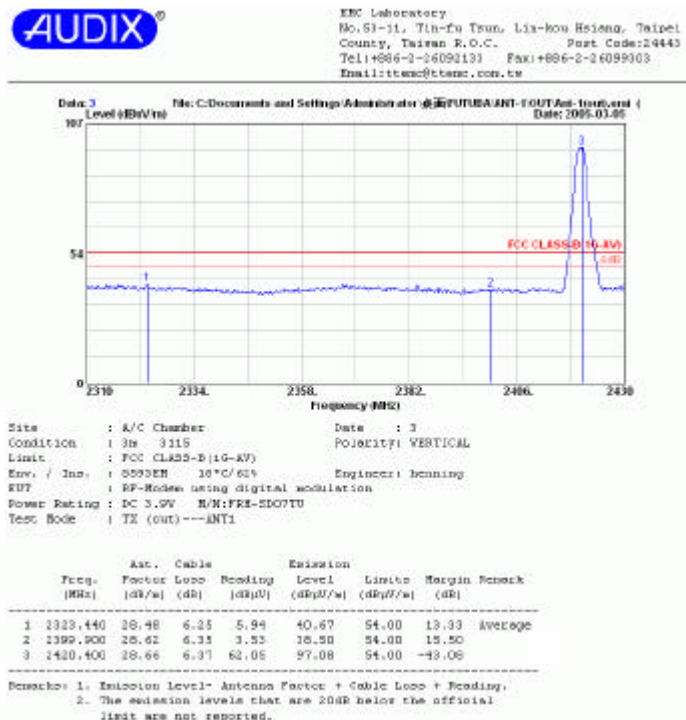
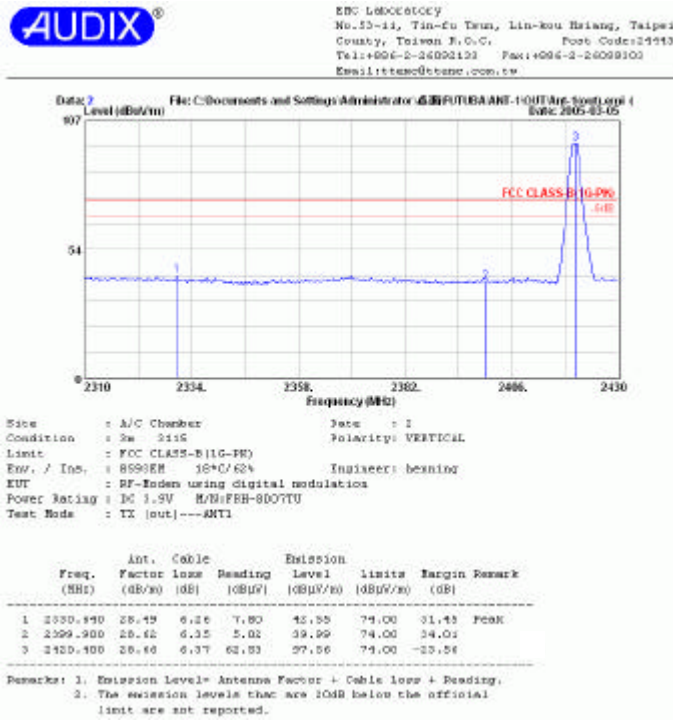

Date of Test : Apr. 13, 2005 Temperature : 21

EUT : RF-Modem using digital modulation with Pencil type antenna Humidity : 59%

Test Mode : Transmitting Mode, Frequency: 2473MHz

	Emission Frequency MHz	Antenna Factor dB/m	Cable Loss dB	Meter Reading Horizontal dBμV	Emission Level Horizontal dBμV/m	Limits dBμV/m	Margin dB
Peak	2473.040	28.75	6.43	54.76	89.94	74.00	-15.94
*	2483.600	28.77	6.45	5.36	40.58	74.00	33.42
*	2496.960	28.80	6.46	6.27	41.53	74.00	32.47
Average	2473.040	28.75	6.43	51.76	86.94	54.00	-32.94
*	2483.600	28.77	6.45	2.36	37.58	54.00	16.42
*	2496.960	28.80	6.46	3.27	38.53	54.00	15.47

- Remark : 1. Emission Level = Antenna Factor + Cable Loss + Meter Reading.
 2. High frequency section (spurious in the restricted band 2483.5-2500MHz).
 3. ‘*’ The field strength of emission appearing within Part 15.205(a) shall not exceed the limits shown in section 15.209.

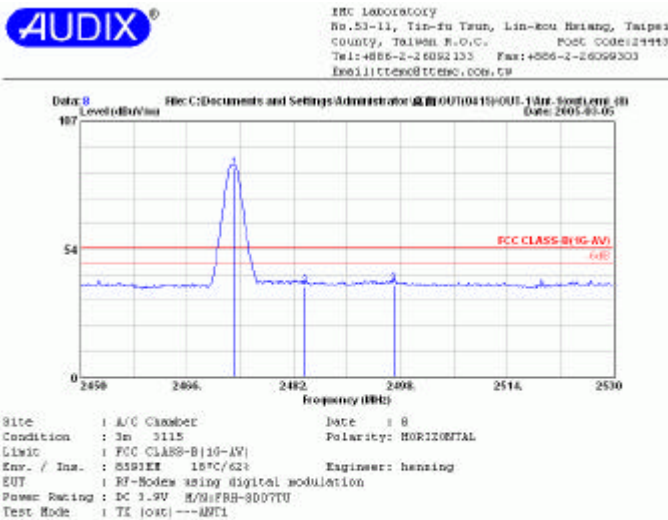

Freq. (MHz)	Ant. Factor (dB/m)	Cable Loss (dB)	Reading (dBμV)	Emission Level (dBμV/m)	Limits (dBμV/m)	Margin (dB)	Remark
1 2473.040	28.75	6.43	51.76	86.94	54.00	-32.94	Average
2 2483.600	28.77	6.45	2.36	37.58	54.00	16.42	
3 2496.960	28.80	6.46	3.27	38.53	54.00	15.47	

Remarks: 1. Emission Level= Antenna Factor + Cable Loss + Reading.
 2. The emission levels that are 20dB below the official limit are not reported.

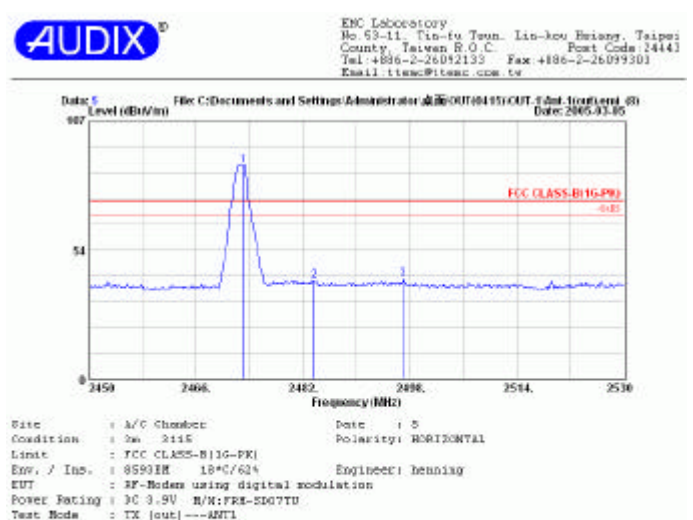

Freq. (MHz)	Ant. Factor (dB/m)	Cable Loss (dB)	Reading (dBμV)	Emission Level (dBμV/m)	Limits (dBμV/m)	Margin (dB)	Remark
1 2473.040	28.75	6.43	54.76	89.94	74.00	-15.94	Peak
2 2483.600	28.77	6.45	5.36	40.58	74.00	33.42	
3 2496.960	28.80	6.46	6.27	41.53	74.00	32.47	

Remarks: 1. Emission Level= Antenna Factor + Cable Loss + Reading.
 2. The emission levels that are 20dB below the official limit are not reported.

Date of Test : Apr. 13, 2005 Temperature : 21
 EUT : RF-Modem using digital modulation with Pencil type antenna Humidity : 59%
 Test Mode : Transmitting Mode, Frequency: 2473MHz

	Emission Frequency MHz	Antenna Factor dB/m	Cable Loss dB	Meter Reading Vertical dBμV	Emission Level Vertical dBμV/m	Limits dBμV/m	Margin dB
Peak	2473.040	28.75	6.43	63.11	98.29	74.00	-24.29
*	1483.600	28.77	6.45	4.01	39.23	74.00	34.77
*	2498.560	28.80	6.47	7.45	42.72	74.00	31.28
Average	2473.040	28.75	6.43	60.11	95.29	54.00	-41.29
*	2483.600	28.77	6.45	2.01	37.23	54.00	16.77
*	2498.560	28.80	6.47	4.45	39.72	54.00	14.28

- Remark : 1. Emission Level = Antenna Factor + Cable Loss + Meter Reading.
 2. High frequency section (spurious in the restricted band 2483.5-2500MHz).
 3. ‘*’ The field strength of emission appearing within Part 15.205(a) shall not exceed the limits shown in section 15.209.

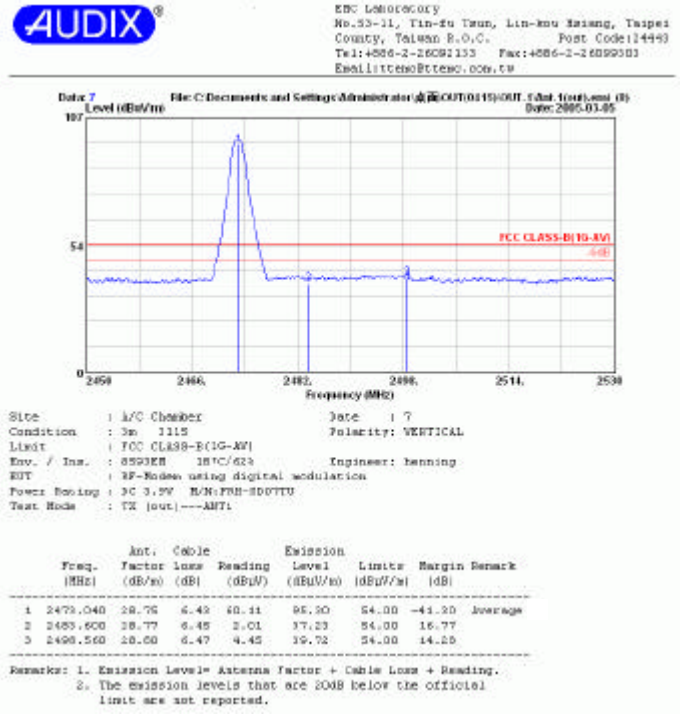
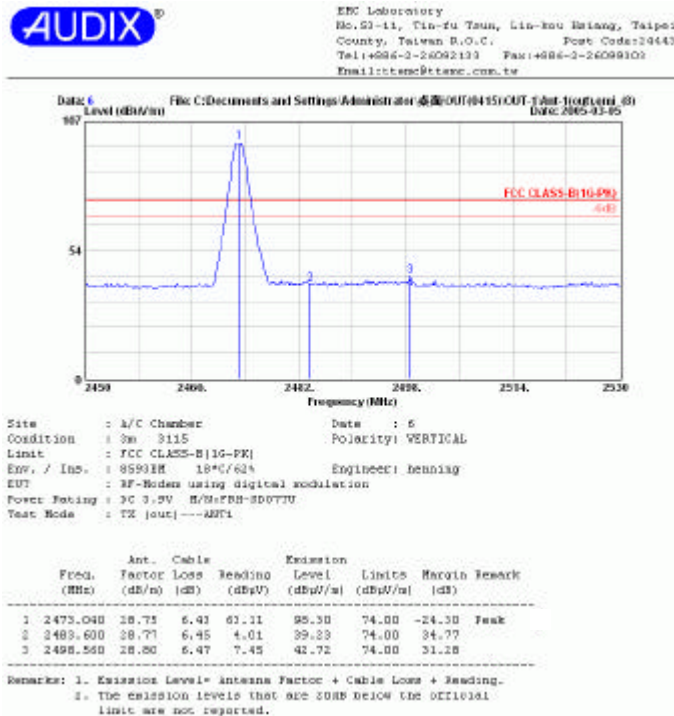

Date of Test : Mar. 05, 2005 Temperature : 18

EUT : RF-Modem using digital modulation w/ Pedestal base with flexible type antenna Humidity : 62%

Test Mode : Transmitting Mode, Frequency: 2420MHz

	Emission Frequency MHz	Antenna Factor dB/m	Cable Loss dB	Meter Reading Horizontal dBμV	Emission Level Horizontal dBμV/m	Limits dBμV/m	Margin dB
Peak *	2314.080	28.45	6.24	8.65	43.34	74.00	30.66
	2399.900	28.62	6.35	5.16	40.13	74.00	33.87
	2420.400	28.66	6.37	51.23	86.26	74.00	-12.26
Average *	2330.040	28.49	6.26	6.43	41.18	54.00	12.82
	2399.900	28.62	6.35	3.39	38.36	54.00	15.64
	2420.040	28.66	6.37	48.09	83.12	54.00	-29.12

- Remark : 1. Emission Level = Antenna Factor + Cable Loss + Meter Reading.
 2. Low frequency section (spurious in the restricted band 2310-2390MHz).
 3. ‘*’ The field strength of emission appearing within Part 15.205(a) shall not exceed the limits shown in section 15.209.

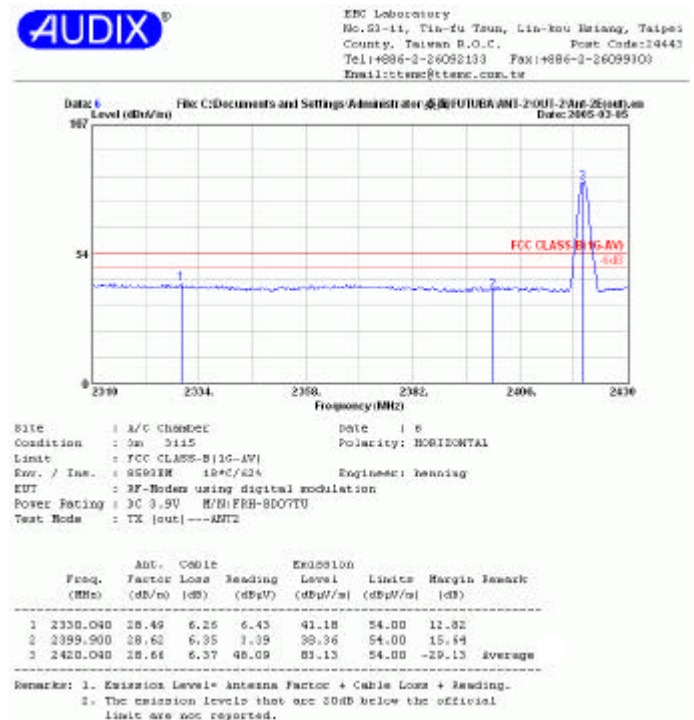
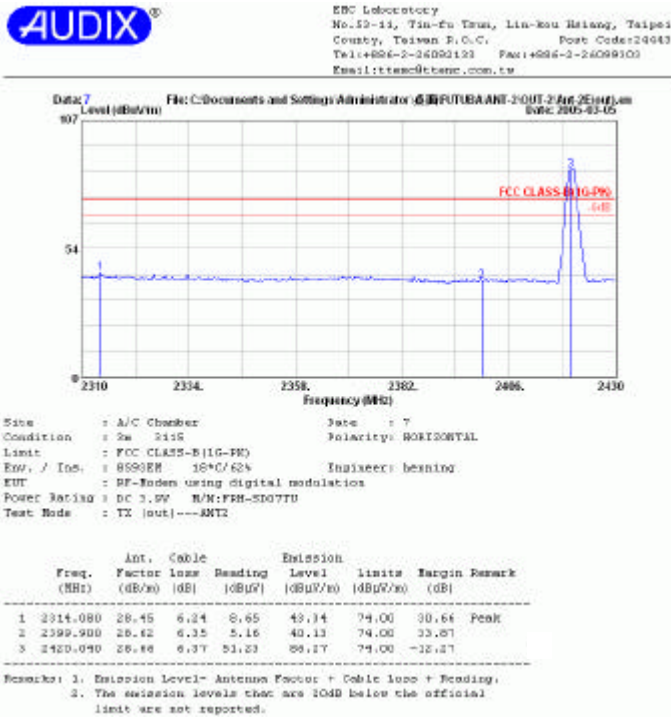

Date of Test : Mar. 05, 2005 Temperature : 18

EUT : RF-Modem using digital modulation w/ Pedestal base with flexible type antenna Humidity : 62%

Test Mode : Transmitting Mode, Frequency: 2420MHz

	Emission Frequency MHz	Antenna Factor dB/m	Cable Loss dB	Meter Reading Vertical dBμV	Emission Level Vertical dBμV/m	Limits dBμV/m	Margin dB
Peak *	2322.480	28.48	6.25	8.33	43.06	74.00	30.94
	2399.900	28.62	6.35	4.69	39.66	74.00	34.34
	2420.400	28.66	6.37	61.29	96.32	74.00	-22.32
Average *	2365.080	28.55	7.00	41.86	77.41	54.00	-23.41
	2399.900	28.62	6.35	3.09	38.06	54.00	15.94
	2420.400	28.66	6.37	62.47	97.50	54.00	-43.50

- Remark : 1. Emission Level = Antenna Factor + Cable Loss + Meter Reading.
 2. Low frequency section (spurious in the restricted band 2310-2390MHz).
 3. ‘*’ The field strength of emission appearing within Part 15.205(a) shall not exceed the limits shown in section 15.209.

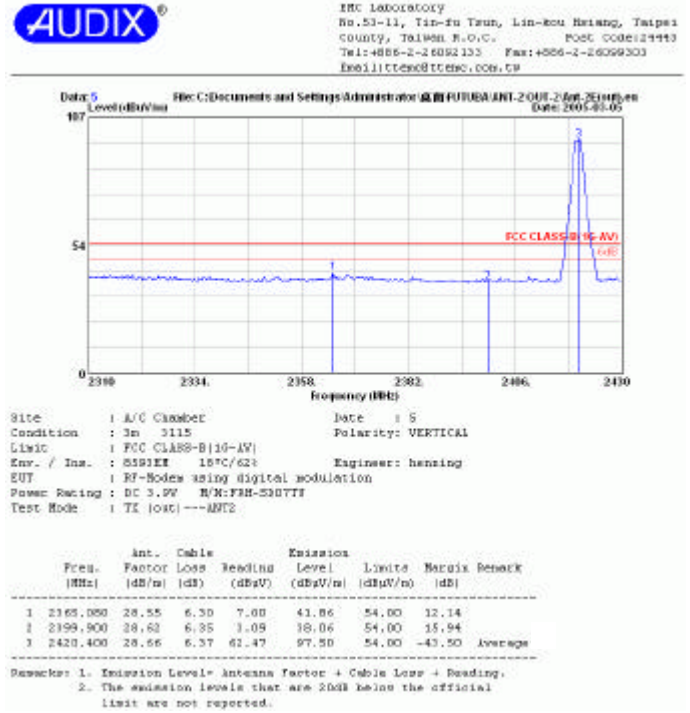
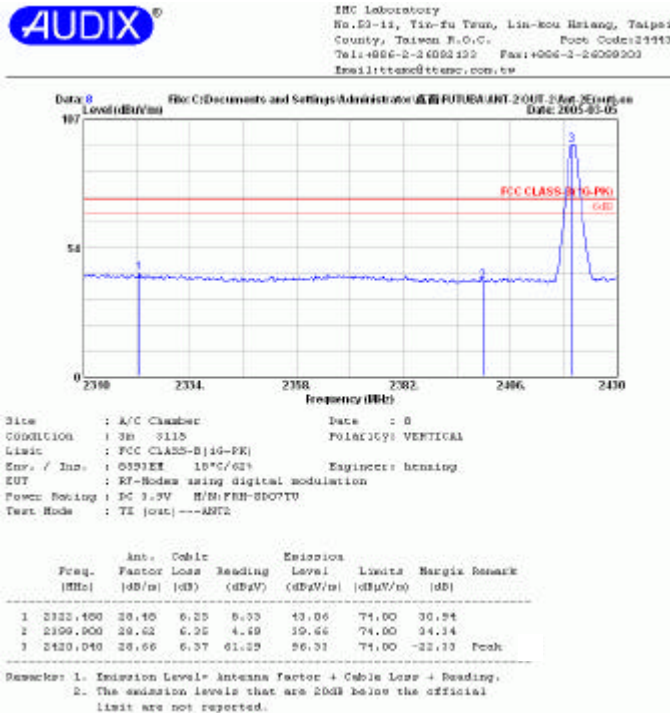

Date of Test : Apr. 13, 2005 Temperature : 21

EUT : RF-Modem using digital modulation w/ Pedestal base with flexible type antenna Humidity : 59%

Test Mode : Transmitting Mode, Frequency: 2473MHz

	Emission Frequency MHz	Antenna Factor dB/m	Cable Loss dB	Meter Reading Horizontal dBμV	Emission Level Horizontal dBμV/m	Limits dBμV/m	Margin dB
Peak	2473.040	28.75	6.43	52.24	87.42	74.00	-13.42
*	2483.600	28.77	6.45	7.06	42.28	74.00	31.72
*	2488.160	28.77	6.45	7.08	42.30	74.00	31.70
Average	2473.040	28.75	6.43	49.24	84.42	54.00	-30.42
*	2483.600	28.77	6.45	5.06	40.28	54.00	13.72
*	2488.160	28.77	6.45	4.08	39.30	54.00	14.70

- Remark : 1. Emission Level = Antenna Factor + Cable Loss + Meter Reading.
 2. High frequency section (spurious in the restricted band 2483.5-2500MHz).
 3. ‘*’ The field strength of emission appearing within Part 15.205(a) shall not exceed the limits shown in section 15.209.

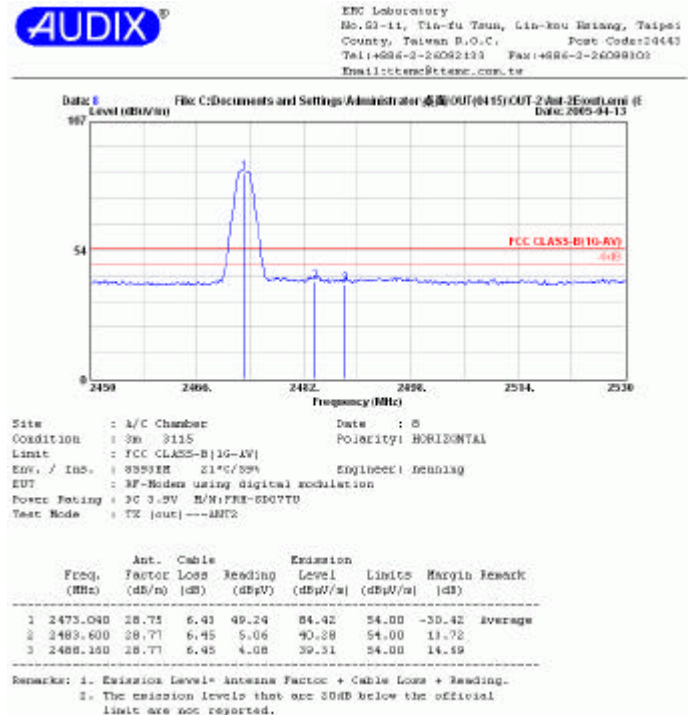
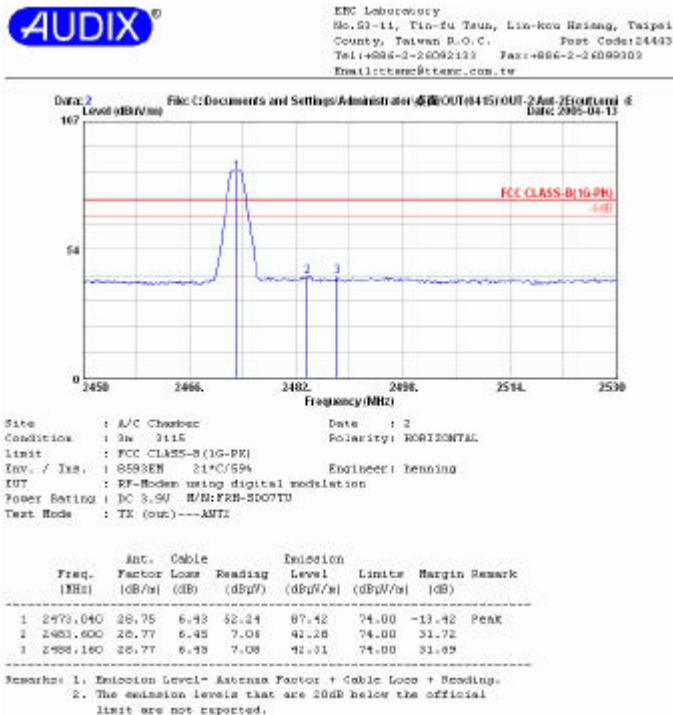

Date of Test : Apr. 13, 2005 Temperature : 21

EUT : RF-Modem using digital modulation w/
Pedestal base with flexible type antenna Humidity : 59%

Test Mode : Transmitting Mode, Frequency: 2473MHz

	Emission Frequency MHz	Antenna Factor dB/m	Cable Loss dB	Meter Reading Vertical dBμV	Emission Level Vertical dBμV/m	Limits dBμV/m	Margin dB
Peak	2473.040	28.75	6.43	63.82	99.00	74.00	-25.00
*	2483.600	28.77	6.45	6.13	41.35	74.00	32.65
*	2499.520	28.80	6.47	9.29	44.56	74.00	29.44
Average	2473.040	28.75	6.43	59.82	95.00	54.00	-41.00
*	2483.600	28.77	6.45	4.13	39.35	54.00	14.65
*	2499.520	28.80	6.47	6.29	41.56	54.00	12.44

- Remark : 1. Emission Level = Antenna Factor + Cable Loss + Meter Reading.
 2. High frequency section (spurious in the restricted band 2483.5-2500MHz).
 3. ‘*’ The field strength of emission appearing within Part 15.205(a) shall not exceed the limits shown in section 15.209.

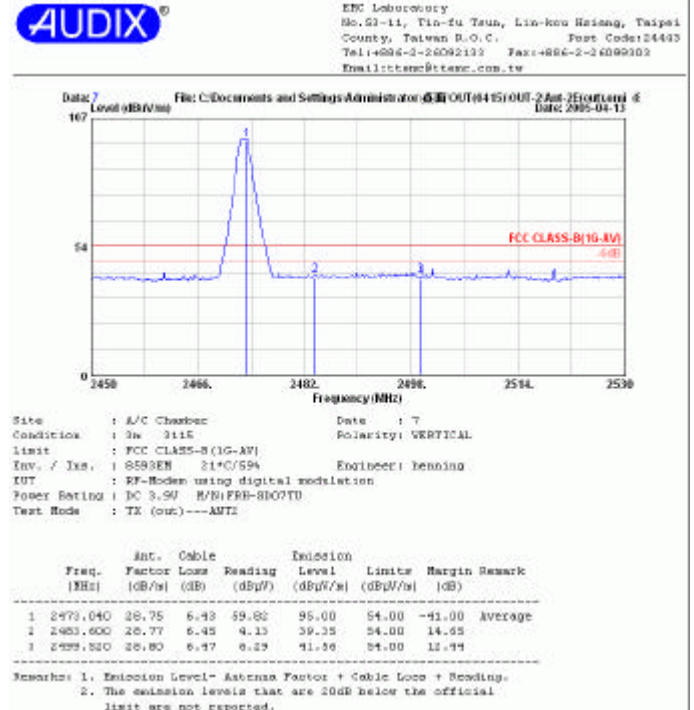
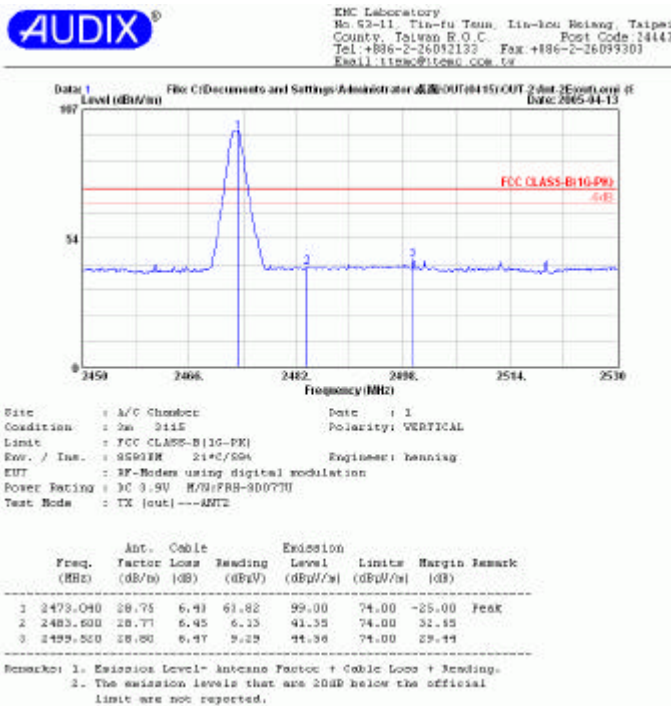

Date of Test : Mar. 05, 2005 Temperature : 18
 EUT : RF-Modem using digital modulation w/ Pedestal base with Rigid type antenna Humidity : 62%
 Test Mode : Transmitting Mode, Frequency: 2420MHz

	Emission Frequency MHz	Antenna Factor dB/m	Cable Loss dB	Meter Reading Horizontal dBμV	Emission Level Horizontal dBμV/m	Limits dBμV/m	Margin dB
Peak *	2368.440	28.55	6.31	7.76	42.62	74.00	31.38
	2399.900	28.62	6.35	4.92	39.89	74.00	34.11
	2420.400	28.66	6.37	49.35	84.38	74.00	-10.38
Average *	2316.000	28.46	6.24	6.25	40.95	54.00	13.05
	2399.900	28.62	6.35	3.67	38.64	54.00	15.36
	2420.040	28.66	6.37	51.88	86.91	54.00	-32.91

- Remark : 1. Emission Level = Antenna Factor + Cable Loss + Meter Reading.
 2. Low frequency section (spurious in the restricted band 2310-2390MHz).
 3. ‘*’ The field strength of emission appearing within Part 15.205(a) shall not exceed the limits shown in section 15.209.

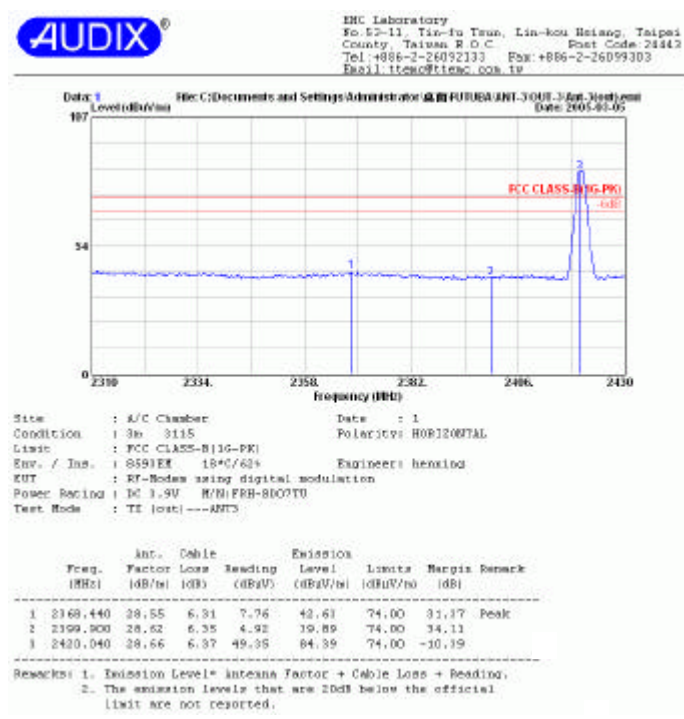

Date of Test : Mar. 05, 2005 Temperature : 18
 EUT : RF-Modem using digital modulation w/ Pedestal base with Rigid type antenna Humidity : 62%
 Test Mode : Transmitting Mode, Frequency: 2420MHz

	Emission Frequency MHz	Antenna Factor dB/m	Cable Loss dB	Meter Reading Vertical dBμV	Emission Level Vertical dBμV/m	Limits dBμV/m	Margin dB
Peak *	2312.640	28.45	6.24	9.64	44.33	74.00	29.67
	2399.900	28.62	6.35	5.75	40.72	74.00	33.28
	2420.400	28.66	6.37	60.31	95.34	74.00	-21.34
Average *	2337.840	28.50	6.27	6.37	41.14	54.00	12.86
	2399.900	28.62	6.35	3.32	38.29	54.00	15.71
	2420.400	28.66	6.37	61.57	96.60	54.00	-42.60

- Remark : 1. Emission Level = Antenna Factor + Cable Loss + Meter Reading.
 2. Low frequency section (spurious in the restricted band 2310-2390MHz).
 3. ‘*’ The field strength of emission appearing within Part 15.205(a) shall not exceed the limits shown in section 15.209.

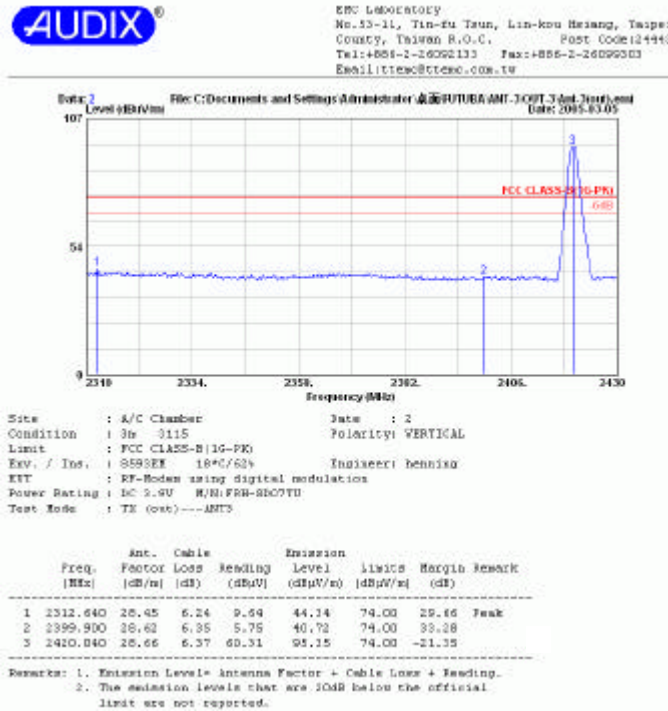

Date of Test : Apr. 13, 2005 Temperature : 21
 EUT : RF-Modem using digital modulation w/ Pedestal base with Rigid type antenna Humidity : 59%
 Test Mode : Transmitting Mode, Frequency: 2473MHz

	Emission Frequency MHz	Antenna Factor dB/m	Cable Loss dB	Meter Reading Horizontal dBμV	Emission Level Horizontal dBμV/m	Limits dBμV/m	Margin dB
Peak	2473.040	28.75	6.43	48.69	83.87	74.00	-9.87
*	2483.600	28.77	6.45	5.14	40.36	74.00	33.64
*	2487.600	28.77	6.45	6.46	41.68	74.00	32.32
Average	2473.040	28.75	6.43	46.69	81.87	54.00	-27.87
*	2483.600	28.77	6.45	4.14	39.36	54.00	14.64
*	2487.600	28.77	6.45	3.46	38.68	54.00	15.32

- Remark : 1. Emission Level = Antenna Factor + Cable Loss + Meter Reading.
 2. High frequency section (spurious in the restricted band 2483.5-2500MHz).
 3. ‘*’ The field strength of emission appearing within Part 15.205(a) shall not exceed the limits shown in section 15.209.

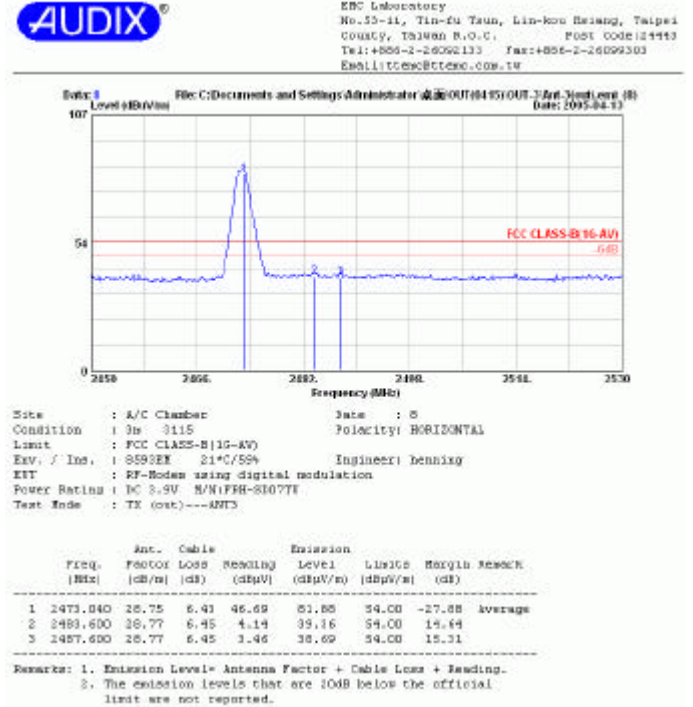
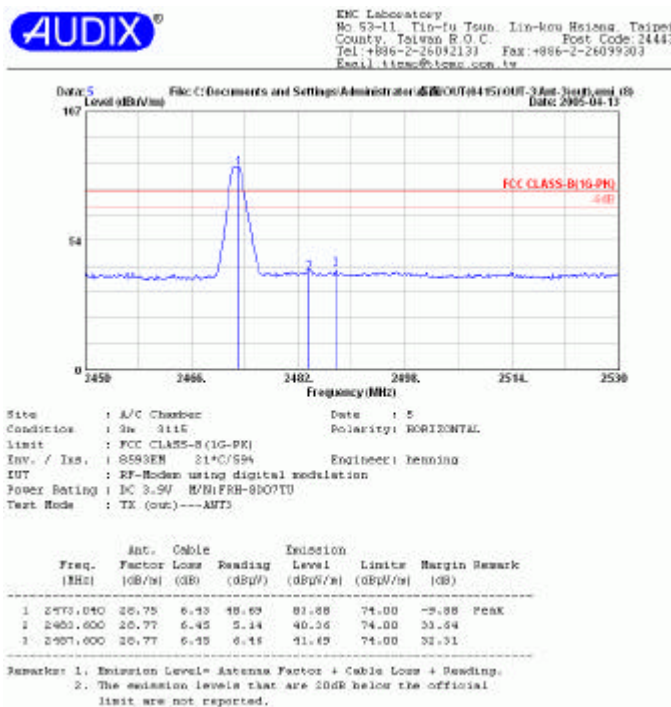

Date of Test : Apr. 13, 2005 Temperature : 21

EUT : RF-Modem using digital modulation w/ Pedestal base with Rigid type antenna Humidity : 59%

Test Mode : Transmitting Mode, Frequency: 2473MHz

	Emission Frequency MHz	Antenna Factor dB/m	Cable Loss dB	Meter Reading Vertical dBμV	Emission Level Vertical dBμV/m	Limits dBμV/m	Margin dB
Peak	2473.040	28.75	6.43	63.88	99.06	74.00	-25.06
*	2483.600	28.77	6.45	4.45	39.67	74.00	34.33
*	2488.240	28.77	6.45	6.79	42.01	74.00	31.99
Average	2473.040	28.75	6.43	60.88	96.06	54.00	-42.06
*	2483.600	28.77	6.45	2.45	37.67	54.00	16.33
*	2488.240	28.77	6.45	4.79	40.01	54.00	13.99

- Remark : 1. Emission Level = Antenna Factor + Cable Loss + Meter Reading.
 2. High frequency section (spurious in the restricted band 2483.5-2500MHz).
 3. ‘*’ The field strength of emission appearing within Part 15.205(a) shall not exceed the limits shown in section 15.209.

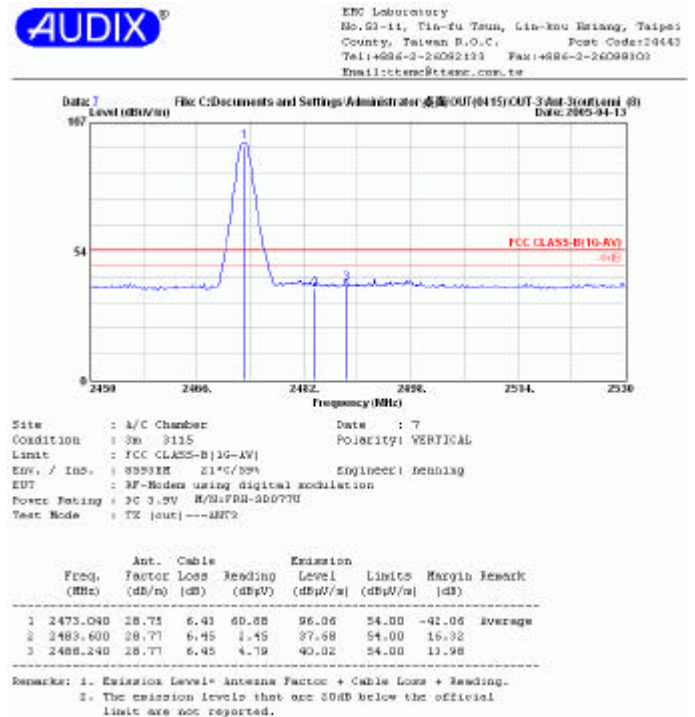
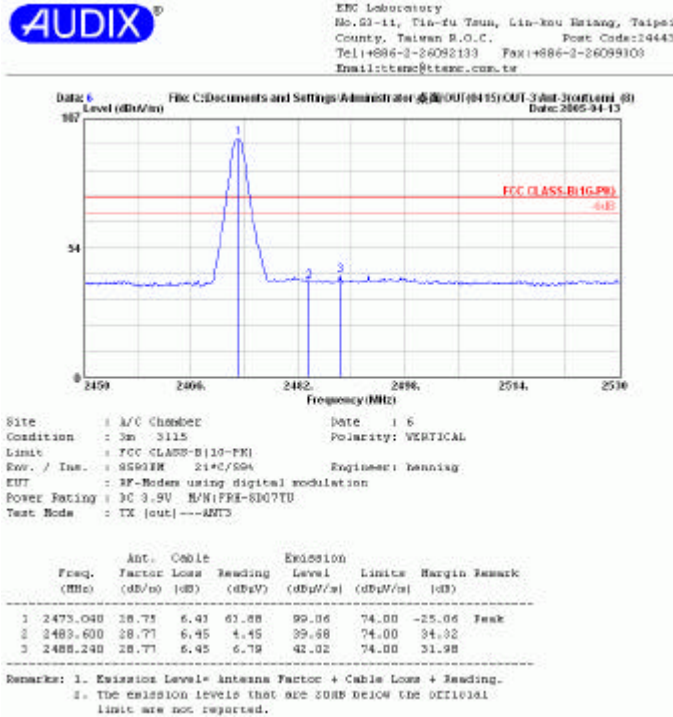

Date of Test : Mar. 05, 2005 Temperature : 18
 EUT : RF-Modem using digital modulation w/ Flat type, two CoAx Cables Humidity : 62%
 Test Mode : Transmitting Mode, Frequency: 2420MHz

	Emission Frequency MHz	Antenna Factor dB/m	Cable Loss dB	Meter Reading Horizontal dBμV	Emission Level Horizontal dBμV/m	Limits dBμV/m	Margin dB
Peak *	2317.080	28.46	6.25	7.96	42.67	74.00	31.33
	2399.900	28.62	6.35	5.33	40.30	74.00	33.70
	2420.400	28.66	6.37	49.23	84.26	74.00	-10.26
Average *	2315.280	28.45	6.24	7.30	41.99	54.00	12.01
	2399.900	28.62	6.35	3.84	38.81	54.00	15.19
	2420.040	28.66	6.37	48.81	83.84	54.00	-29.84

- Remark : 1. Emission Level = Antenna Factor + Cable Loss + Meter Reading.
 2. Low frequency section (spurious in the restricted band 2310-2390MHz).
 3. ‘*’ The field strength of emission appearing within Part 15.205(a) shall not exceed the limits shown in section 15.209.

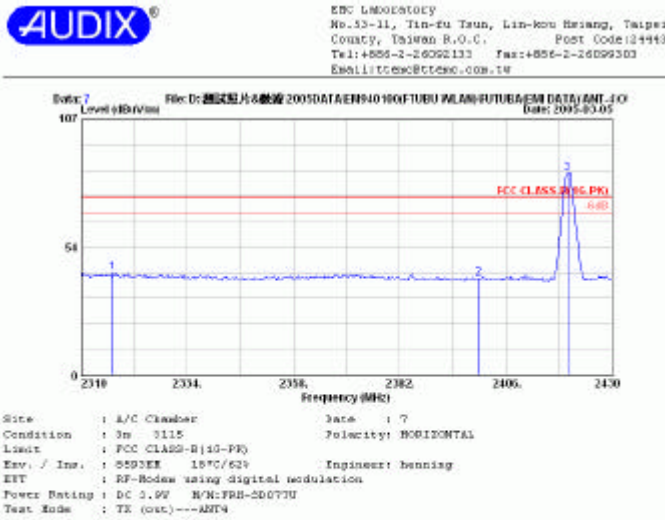

Site	Condition	Limit	Env. / Ins.	EUT	Power Rating	Test Mode
A/C Chamber	3m 3115	FCC CLASS-B(1G-PK)	85DBE 18°C/62%	RF-Modem using digital modulation	DC 3.5W	TX (out)---ANT4

Remarks: 1. Emission Level= Antenna Factor + Cable Loss + Reading.
 2. The emission levels that are 20dB below the official limit are not reported.

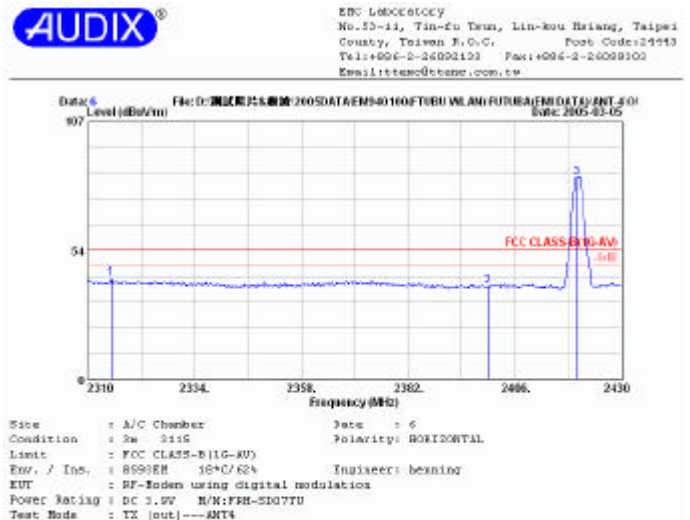

Site	Condition	Limit	Env. / Ins.	EUT	Power Rating	Test Mode
A/C Chamber	3m 3115	FCC CLASS-B(1G-AV)	85DBE 18°C/62%	RF-Modem using digital modulation	DC 3.5W	TX (out)---ANT4

Remarks: 1. Emission Level= Antenna Factor + Cable Loss + Reading.
 2. The emission levels that are 20dB below the official limit are not reported.

Date of Test : Mar. 05, 2005 Temperature : 18

EUT : RF-Modem using digital modulation w/ Flat type, two CoAx Cables Humidity : 62%

Test Mode : Transmitting Mode, Frequency: 2420MHz

	Emission Frequency MHz	Antenna Factor dB/m	Cable Loss dB	Meter Reading Vertical dBμV	Emission Level Vertical dBμV/m	Limits dBμV/m	Margin dB
Peak *	2375.880	28.57	6.32	10.62	45.51	74.00	28.49
	2399.900	28.62	6.35	4.99	39.96	74.00	34.04
	2420.400	28.66	6.37	50.90	85.93	74.00	-11.93
Average *	2321.040	28.46	6.25	7.14	41.85	54.00	12.15
	2399.900	28.62	6.35	3.18	38.15	54.00	15.85
	2420.400	28.66	6.37	51.08	86.11	54.00	-32.11

- Remark : 1. Emission Level = Antenna Factor + Cable Loss + Meter Reading.
 2. Low frequency section (spurious in the restricted band 2310-2390MHz).
 3. ‘*’ The field strength of emission appearing within Part 15.205(a) shall not exceed the limits shown in section 15.209.

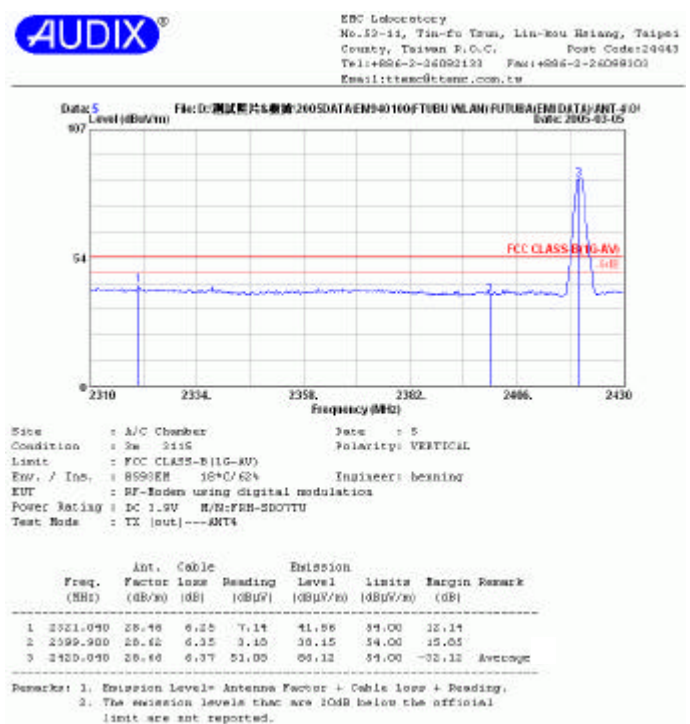
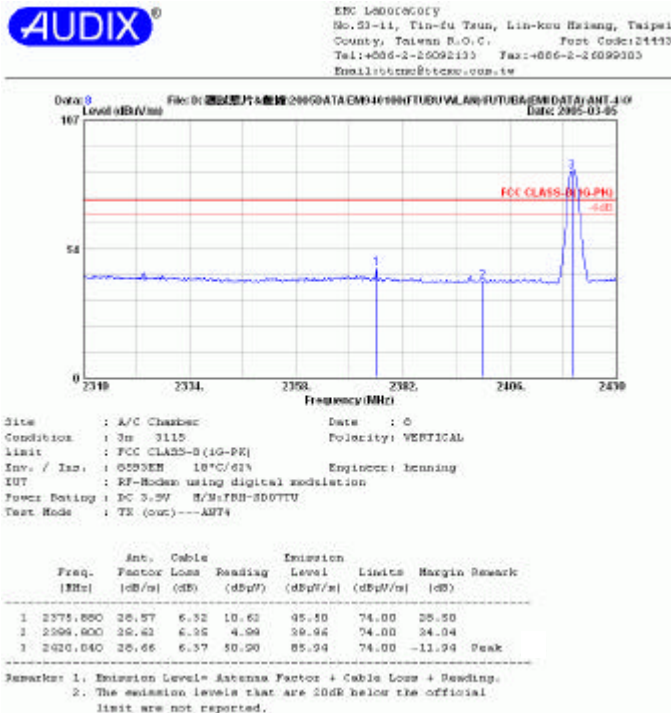

Date of Test : Apr. 13, 2005 Temperature : 21

EUT : RF-Modem using digital modulation w/ Flat type, two CoAx Cables Humidity : 59%

Test Mode : Transmitting Mode, Frequency: 2473MHz

	Emission Frequency MHz	Antenna Factor dB/m	Cable Loss dB	Meter Reading Horizontal dBμV	Emission Level Horizontal dBμV/m	Limits dBμV/m	Margin dB
Peak	2473.040	28.75	6.43	49.69	84.87	74.00	-10.87
*	2483.600	28.77	6.45	6.14	41.36	74.00	32.64
*	2495.040	28.79	6.46	7.27	42.52	74.00	31.48
Average	2473.040	28.75	6.43	45.69	80.87	54.00	-26.87
*	2483.600	28.77	6.45	3.14	38.36	54.00	15.64
*	2495.040	28.79	6.46	4.27	39.52	54.00	14.48

- Remark : 1. Emission Level = Antenna Factor + Cable Loss + Meter Reading.
 2. High frequency section (spurious in the restricted band 2483.5-2500MHz).
 3. ‘*’ The field strength of emission appearing within Part 15.205(a) shall not exceed the limits shown in section 15.209.

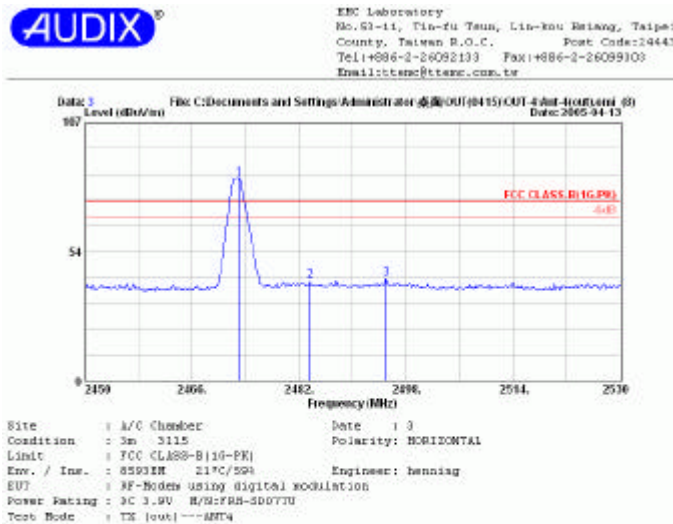

Freq. (MHz)	Ant. Factor (dB/m)	Cable Loss (dB)	Reading (dBμV)	Emission Level (dBμV/m)	Limits (dBμV/m)	Margin (dB)	Remark
1 2473.040	28.75	6.43	49.69	84.87	74.00	-10.87	Peak
2 2483.600	28.77	6.45	6.14	41.36	74.00	32.64	
3 2495.040	28.79	6.46	7.27	42.52	74.00	31.48	

- Remarks: 1. Emission Level= Antenna Factor + Cable Loss + Reading.
 2. The emission levels that are 20dB below the official limit are not reported.

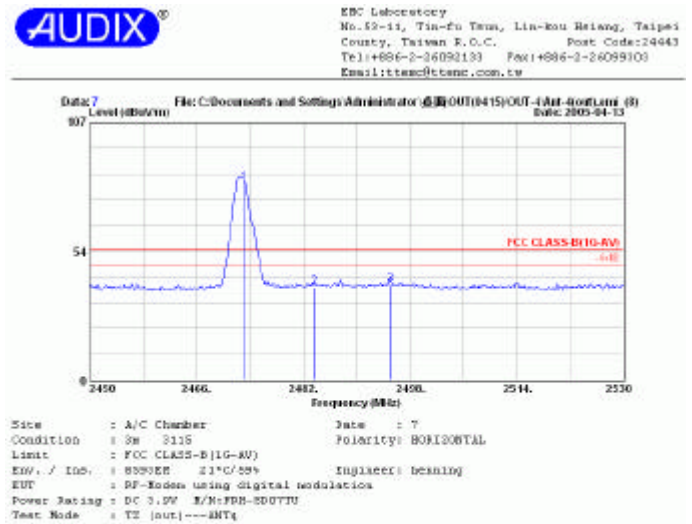

Freq. (MHz)	Ant. Factor (dB/m)	Cable Loss (dB)	Reading (dBμV)	Emission Level (dBμV/m)	Limits (dBμV/m)	Margin (dB)	Remark
1 2473.040	28.75	6.43	45.69	80.87	54.00	-26.87	Average
2 2483.600	28.77	6.45	3.14	38.36	54.00	15.64	
3 2495.040	28.79	6.46	4.27	39.52	54.00	14.48	

- Remarks: 1. Emission Level= Antenna Factor + Cable Loss + Reading.
 2. The emission levels that are 10dB below the official limit are not reported.

Date of Test : Apr. 13, 2005 Temperature : 21
 EUT : RF-Modem using digital modulation w/ Flat type, two CoAx Cables Humidity : 59%
 Test Mode : Transmitting Mode, Frequency: 2473MHz

	Emission Frequency MHz	Antenna Factor dB/m	Cable Loss dB	Meter Reading Vertical dBμV	Emission Level Vertical dBμV/m	Limits dBμV/m	Margin dB
Peak	2473.040	28.75	6.43	62.88	98.06	74.00	-24.06
*	2483.600	28.77	6.45	5.45	40.67	74.00	33.33
*	2492.560	28.79	6.46	6.54	41.79	74.00	32.21
Average	2473.040	28.75	6.43	60.88	96.06	54.00	-42.06
*	2483.600	28.77	6.45	4.45	39.67	54.00	14.33
*	2492.560	28.79	6.46	4.54	39.79	54.00	14.21

- Remark : 1. Emission Level = Antenna Factor + Cable Loss + Meter Reading.
 2. High frequency section (spurious in the restricted band 2483.5-2500MHz).
 3. ‘*’ The field strength of emission appearing within Part 15.205(a) shall not exceed the limits shown in section 15.209.

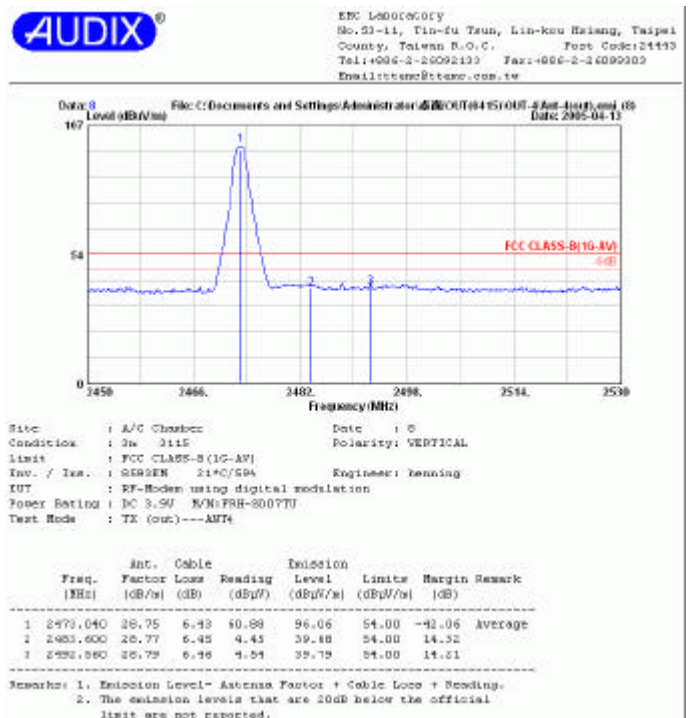
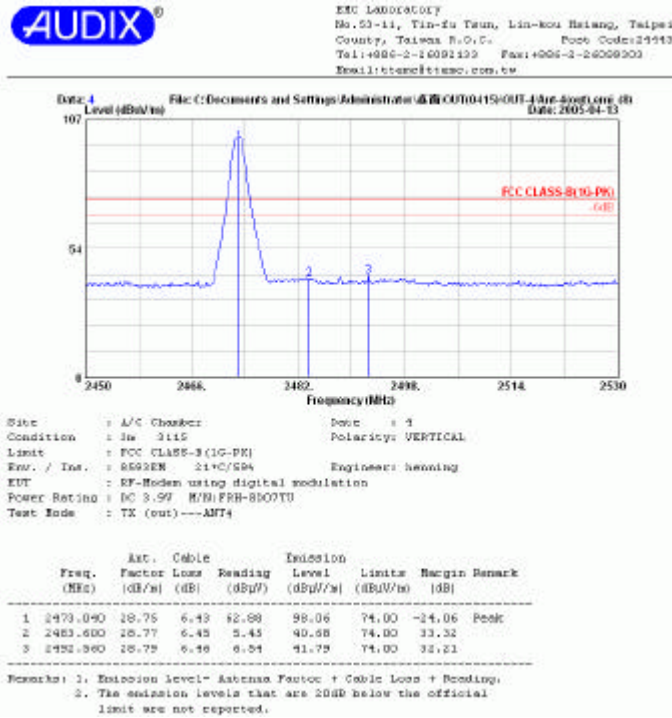

Date of Test : Mar. 05, 2005 Temperature : 18

EUT : RF-Modem using digital modulation w/
Flat type, single CoAx Cable Humidity : 62%

Test Mode : Transmitting Mode, Frequency: 2420MHz

	Emission Frequency MHz	Antenna Factor dB/m	Cable Loss dB	Meter Reading Horizontal dBµV	Emission Level Horizontal dBµV/m	Limits dBµV/m	Margin dB
Peak *	2310.240	28.45	6.24	8.57	43.26	74.00	30.74
	2399.900	28.62	6.35	5.68	40.65	74.00	33.35
	2420.400	28.66	6.37	45.76	80.79	74.00	-6.79
Average *	2336.280	28.50	6.27	6.11	40.88	54.00	13.12
	2399.900	28.62	6.35	3.18	38.15	54.00	15.85
	2420.040	28.66	6.37	48.72	83.75	54.00	-29.75

- Remark : 1. Emission Level = Antenna Factor + Cable Loss + Meter Reading.
 2. Low frequency section (spurious in the restricted band 2310-2390MHz).
 3. ‘*’ The field strength of emission appearing within Part 15.205(a) shall not exceed the limits shown in section 15.209.

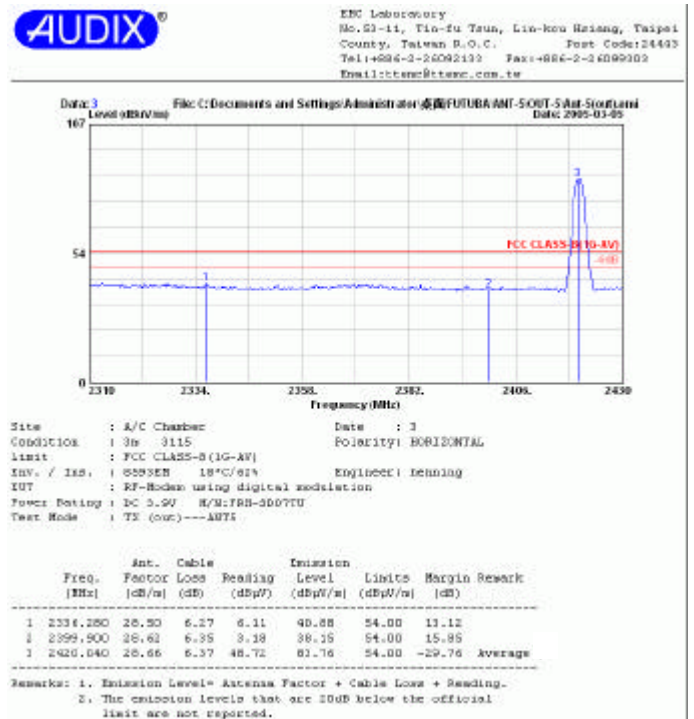
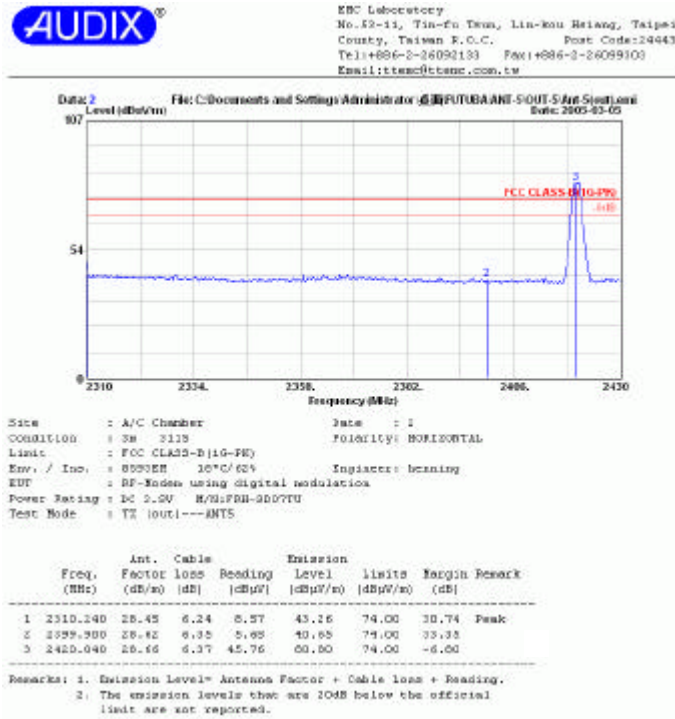

Date of Test : Mar. 05, 2005 Temperature : 18
 EUT : RF-Modem using digital modulation w/ Flat type, single CoAx Cable Humidity : 62%
 Test Mode : Transmitting Mode, Frequency: 2420MHz

	Emission Frequency MHz	Antenna Factor dB/m	Cable Loss dB	Meter Reading Vertical dBμV	Emission Level Vertical dBμV/m	Limits dBμV/m	Margin dB
Peak *	2312.880	28.45	6.24	8.10	42.79	74.00	31.21
	2399.900	28.62	6.35	4.97	39.94	74.00	34.06
	2420.400	28.66	6.37	55.23	90.26	74.00	-16.26
Average *	2313.480	28.45	6.24	7.02	41.71	54.00	12.29
	2399.900	28.62	6.35	3.32	38.29	54.00	15.71
	2420.400	28.66	6.37	51.97	87.00	54.00	-33.00

- Remark : 1. Emission Level = Antenna Factor + Cable Loss + Meter Reading.
 2. Low frequency section (spurious in the restricted band 2310-2390MHz).
 3. ‘*’ The field strength of emission appearing within Part 15.205(a) shall not exceed the limits shown in section 15.209.

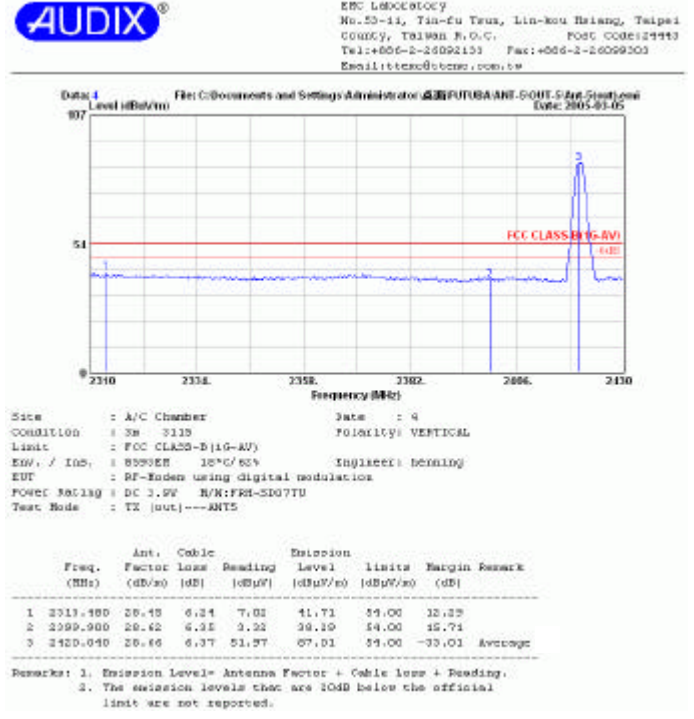
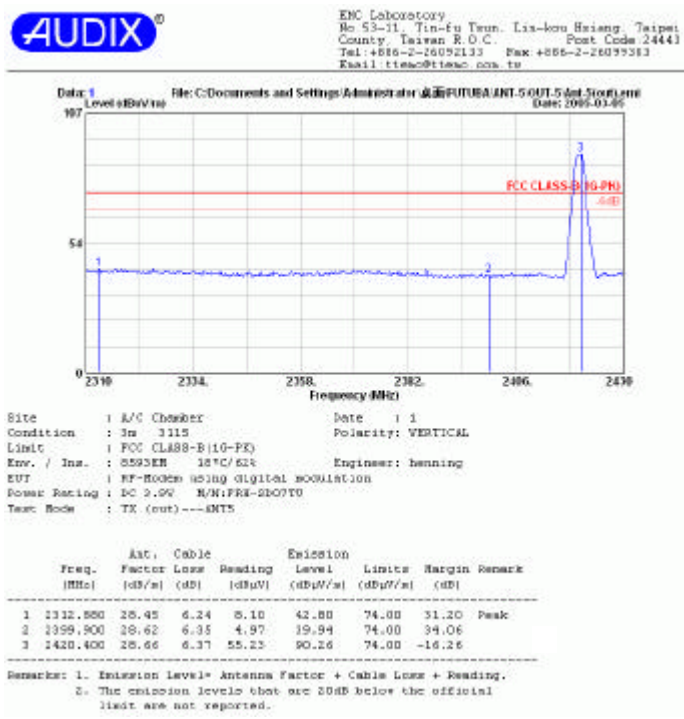

Date of Test : Apr. 13, 2005 Temperature : 21
 EUT : RF-Modem using digital modulation w/ Flat type, single CoAx Cable Humidity : 59%
 Test Mode : Transmitting Mode, Frequency: 2473MHz

	Emission Frequency MHz	Antenna Factor dB/m	Cable Loss dB	Meter Reading Horizontal dBμV	Emission Level Horizontal dBμV/m	Limits dBμV/m	Margin dB
Peak	2473.040	28.75	6.43	54.54	89.72	74.00	-15.72
*	2483.600	28.77	6.45	5.27	40.49	74.00	33.51
*	2491.520	28.79	6.46	6.34	41.59	74.00	32.41
Average	2473.040	28.75	6.43	51.54	86.72	54.00	-32.72
*	2483.600	28.77	6.45	2.27	37.49	54.00	16.51
*	2491.520	28.79	6.46	2.34	37.59	54.00	16.41

- Remark : 1. Emission Level = Antenna Factor + Cable Loss + Meter Reading.
 2. High frequency section (spurious in the restricted band 2483.5-2500MHz).
 3. ‘*’ The field strength of emission appearing within Part 15.205(a) shall not exceed the limits shown in section 15.209.

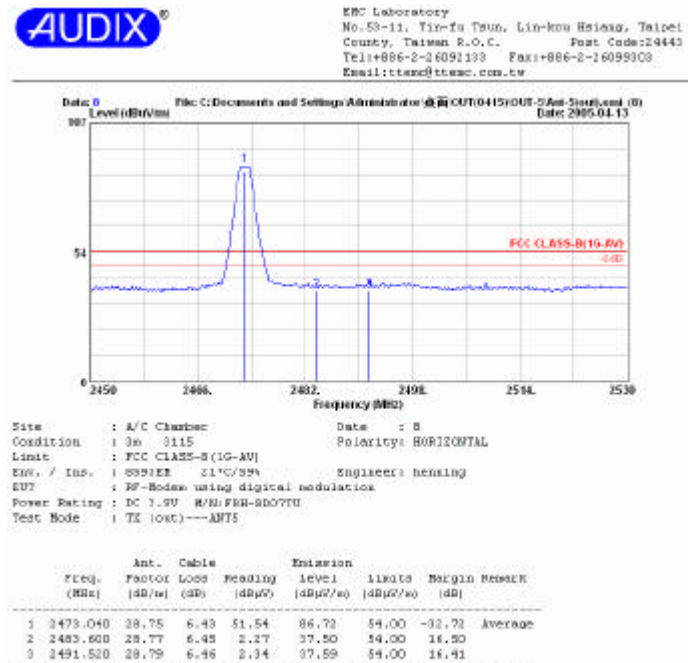
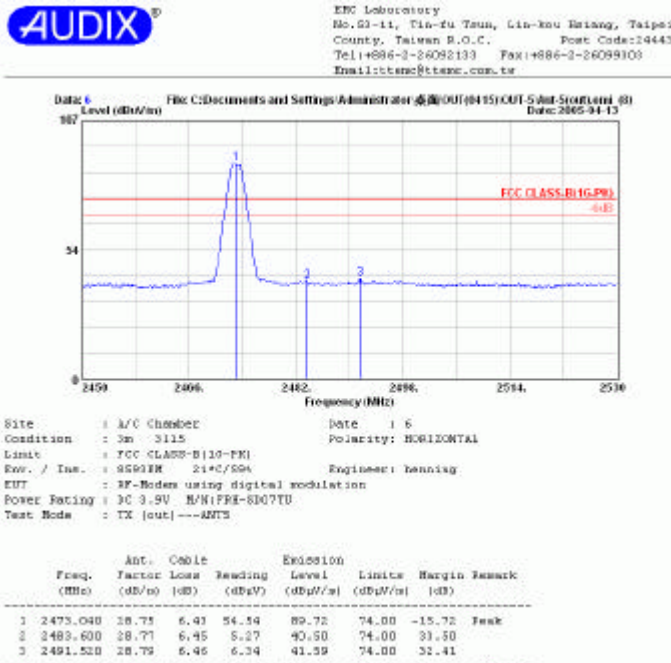

Remarks: 1. Emission Level= Antenna Factor + Cable Loss + Reading.
 2. The emission levels that are 30dB below the official limit are not reported.

REMARKS: 1. Emission Level= Antenna Factor + Cable Loss + Reading.
 2. The emission levels that are 30dB below the official limit are not reported.

Date of Test : Apr. 13, 2005 Temperature : 21
 EUT : RF-Modem using digital modulation w/ Flat type, single CoAx Cable Humidity : 59%
 Test Mode : Transmitting Mode, Frequency: 2473MHz

	Emission Frequency MHz	Antenna Factor dB/m	Cable Loss dB	Meter Reading Vertical dBμV	Emission Level Vertical dBμV/m	Limits dBμV/m	Margin dB
Peak	2473.040	28.75	6.43	58.63	93.81	74.00	-19.81
*	2483.600	28.77	6.45	4.78	40.00	74.00	34.00
*	2492.960	28.79	6.46	6.37	41.62	74.00	32.38
Average	2473.040	28.75	6.43	55.63	90.81	54.00	-36.81
*	2483.600	28.77	6.45	1.78	37.00	54.00	17.00
*	2492.960	28.7	6.46	3.37	38.53	54.00	15.47

- Remark : 1. Emission Level = Antenna Factor + Cable Loss + Meter Reading.
 2. High frequency section (spurious in the restricted band 2483.5-2500MHz).
 3. ‘*’ The field strength of emission appearing within Part 15.205(a) shall not exceed the limits shown in section 15.209.

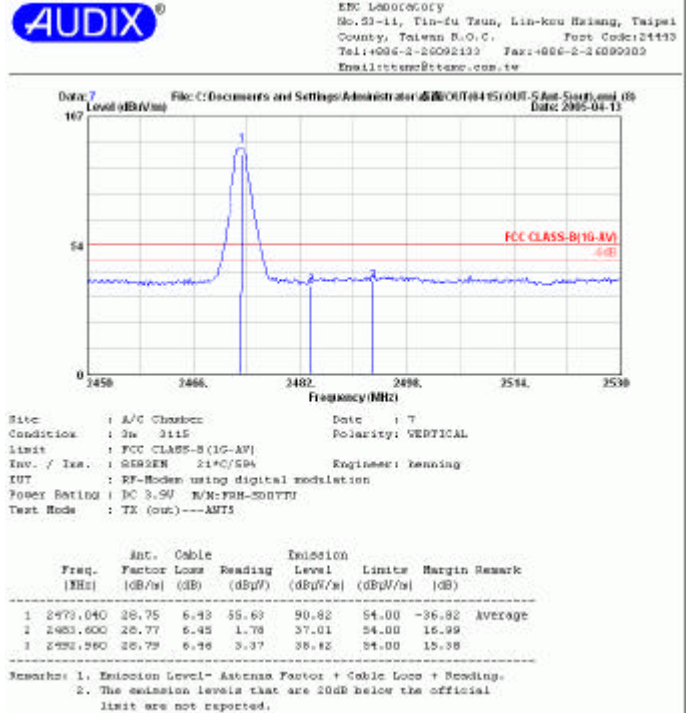
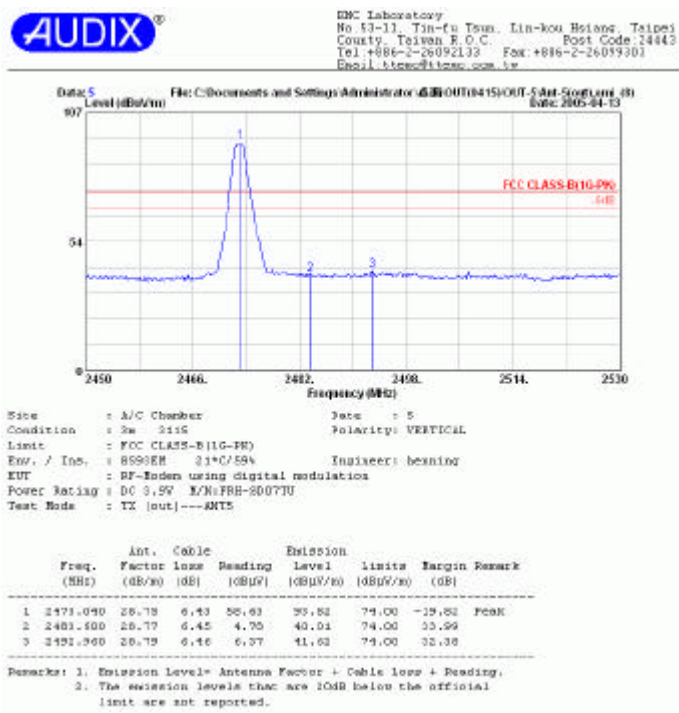

4. DEVIATION TO TEST SPECIFICATIONS

【NONE】