

FDP03TJ010/020

2.4GHz Embedded Type Wireless Modem

Instruction Manual

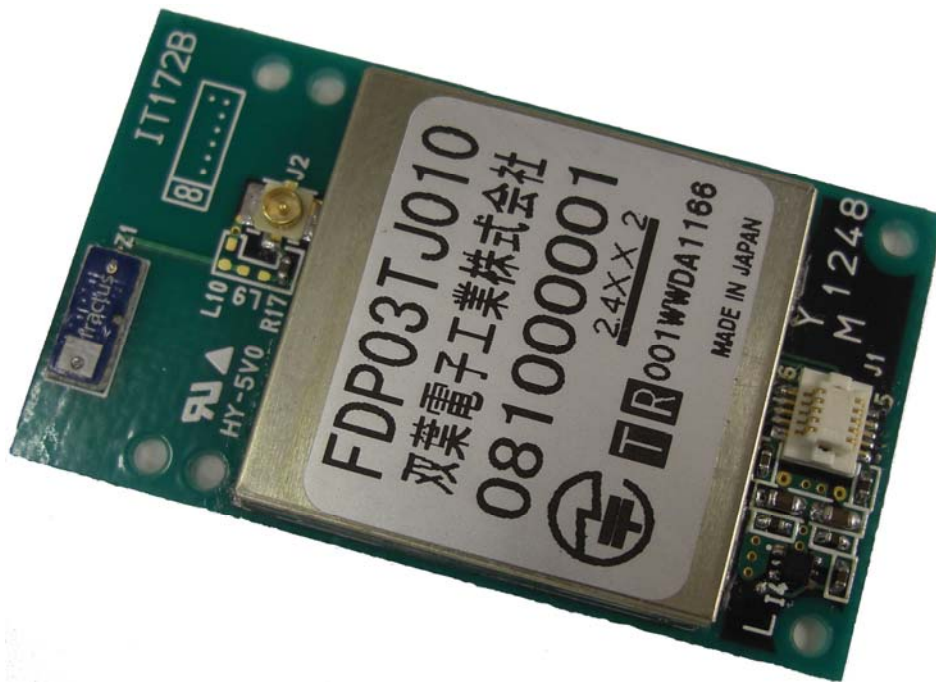

Futaba Corporation

Industrial Radio Control

I Notice

This device complies with part 15 of the FCC rules. Operation is subject to the following two conditions: (1) This device may not cause harmful interference, and (2) this device must accept any interference received, including interference that may cause undesired operation.

This equipment has been tested and found to comply with the limits for a Class A digital device, pursuant to part 15 of the FCC Rules. These limits are designed to provide reasonable protection against harmful interference when the equipment is operated in a commercial environment. This equipment generates, uses, and can radiate radio frequency energy and, if not installed and used in accordance with the instruction manual, may cause harmful interference to radio communications. Operation of this equipment in a residential area is likely to cause harmful interference in which case the user will be required to correct the interference at her/his own expense.

Any unauthorized changes or modifications to this device not expressly approved by Futaba Corporation could void the user's authority to operate the device and possibly result in damage to the equipment and/or cause serious or fatal injuries to the operator or nearby personnel.

This device is intended to be installed and used in accordance with the instructions contained in this manual. Failure to comply with these instructions could void the user's authority to operate the device and possibly result in damage to the equipment and/or cause serious or fatal injuries to the operator or nearby personnel.

II Important Safety Information

The list of dangers, warnings and cautions in this section contain important information that will help ensure safe operation of the system. Please read carefully and understand all of these items. All installers, operators and maintenance personnel should read and understand this information before installation, use, or maintenance of the FDP03TJ010/020.

The FDP03TJ010/020 system by itself is not inherently dangerous. **HOWEVER, WHEN THE FDP03TJ010/020 IS CONNECTED TO OTHER EQUIPMENT FOR THE PURPOSE OF CONTROL, SAFETY AND ALL POSSIBLE ASSOCIATED DANGERS MUST ALWAYS BE GIVEN THE UTMOST CONSIDERATION DURING SYSTEM INTEGRATION, DESIGN, INSTALLATION, AND USE.**

The FDP03TJ010/020 may be used in virtually unlimited applications. Many of these associated systems can, by themselves, pose a mechanical, electrical or other hazard to operators and other persons or equipment. To address all possible applications and associated safety hazards in this manual would be impossible. The warnings below and throughout this manual give information that will allow safe installation and use the modem system applications. If you have questions regarding the safety of your specific application, please contact the appropriate people for help. Your Futaba sales representative, representatives of the equipment being controlled, and the technical support staff at local branch of Futaba Corporation are among those who can provide assistance with your safety concerns.

The following warnings are included in the lists that follow but warrant repetition here:

In installations where the FDP03TJ010/020 is used to control motion or operation of potentially dangerous equipment, it is imperative for safety that all operators and installers be thoroughly trained in the normal function of that equipment before attempting to control it remotely with the FDP03TJ010/020.

To help ensure safe operation of the equipment, the FDP03TJ010/020 must be connected so that it will operate in a fail-safe way. In other words, the equipment being controlled should stop or return to its safest state in the absence of a control signal or total loss of RF transmission from the FDP03TJ010/020. Our system uses one of the most reliable methods available to transmit data using radio signals. Many factors can affect a radio signal that may block it or interfere enough to disrupt regular transmission. Because of this, equipment motion or dangerous electrical current, for example, that continues during a loss-of-signal condition could be very dangerous.

Four symbols are used in the margin of the following section and throughout the manual to indicate the level of hazard or information listed.

The symbols are defined as follows:



Indicates a hazard that *will* cause severe personal injury, death, or substantial property damage if the warning is ignored.



Indicates a hazard that *can* cause severe personal injury, death, or substantial property damage if the warning is ignored.



Indicates a hazard that will or can cause minor personal injury, or property damage if the warning is ignored.



Indicates installation, operation, or maintenance information that is important but not hazard-related.

Please read the following safety information carefully. Some of these notices are duplicated throughout the manual, in areas of associated content, for your benefit.

11.1 General Safety Hazards and Notes



Improper installation and/or operation of the FDP03TJ010/020 can cause serious or fatal injuries to the operator or nearby persons and cause damage to the FDP03TJ010/020, and any equipment it is used to control. Please read and understand this manual completely and the manual of all equipment being controlled before attempting to operate or install this system.



Always keep this manual at a location readily accessible to anyone operating the system and related equipment. Ensure that all operators have read and understood this manual, especially all safety and operation procedures contained in it. Please refer to the section in this manual titled **How to Obtain Help** for the contact that can supply additional manuals or answers to questions not covered in this manual. If this product is passed on to a different user, be sure that this manual accompanies the product.



Be certain that the installer of this equipment reads and understands the instruction manual of *the equipment that is being connecting to* before attempting this installation.



The FDP03TJ010/020 should **NOT** be used in a manner in which failure of the product or loss of the radio signal could cause damage to the equipment being controlled, or to anything in the area in which such equipment is located. All integrated control systems should be designed for “fail-safe” operation so that a temporary or permanent loss of signal will not endanger any person, critical process, or equipment (refer to the beginning of the safety section for further explanation). The system design should ensure that the equipment being controlled will initial to its safest state in the event of signal loss.



The FDP03TJ010/020 contains no user serviceable parts. If the unit requires service, contact your sales representative or local branch of

Futaba Corporation per instructions the section titled **How To Obtain Help**. Do not disassemble or attempt to repair the FDP03TJ010/020 yourself. Doing so could void your warranty and may void the user's authority to operate the device.



Contact Futaba before using the FDP03TJ010/020 in safety critical applications such as medical equipment, aircraft, hazardous materials handling, etc.

II.II Installation Safety Hazards and Notes



Use only the proper regulated DC voltage supplied to the FDP03TJ010/020. Use of any other voltage may permanently damage the modem and/or cause the modem to malfunction and create a shock or fire hazard.



Be certain that all AC power outlets used the power adapters have been properly installed, grounded, and fused. An electrical shock hazard may exist if this unit is powered by a faulty power outlet or source. If such a situation is discovered, immediately discontinue use until the power source and outlet have been properly installed, grounded, and fused by an electrician or other authorized person.



Be sure to wire the power connections correctly. Incorrect wiring can damage the system, cause it to malfunction and/or create a shock and fire hazard.



Ensure that the FDP03TJ010/020 power and the power to the equipment to be controlled are turned off before connecting or disconnecting the cable between them. This will help prevent accidental damage to the system and unexpected operation and/or injury.



Be sure the FDP03TJ010 power, the power to the equipment that is being connecting to it, and the DC power source are all turned off before wiring and connecting the power cable.



Be sure that the supplied power is within the specified range. Voltages outside the specified range may damage the FDP03TJ010/020.



Be sure that the power source has sufficient current capacity. Insufficient current may cause the unit to malfunction.



Securely attach the antenna cable to the FDP03TJ010/020 and equipment/power source to which it is connected. Failure to do so could cause an unexpected system failure.



Below comment should be written on a product label when the FDP03TJ010/020 is embeded into any products.

“This device contains FCC ID:AZP-FDP03”

Antenna Installation Hazards and Notes

⚠ WARNING

Be sure to keep all systems and antennas clear of power lines. Permanent equipment damage and severe shock injury or death can occur if the system contacts power lines.

⚠ WARNING

Contact Futaba before connecting any antenna not provided by Futaba specifically for the FDP03TJ010/020. Attaching any non-authorized antenna may be in violation of FCC regulations.

⚠ WARNING

Before each use, verify that the antenna (and antenna cable, if used) is securely attached and in good condition. A loose antenna or cable may severely reduce the operating range of the system.

NOTE

The FDP03TJ010/020 operates at frequencies in the 2.4 GHz band. These frequencies are more directional than lower frequencies and are easily reflected. If there are metal structures nearby, the effective range may be shortened or the directional properties may be further narrowed. To help avoid this, mount the antenna as far away as possible from surrounding metallic structures.

NOTE

Multipath problems occur easily at frequencies in the 2.4 GHz band. When multipath problems are present, moving the antenna around 10 cm may result in improved communication or, conversely, worsened or complete loss of communication. Futaba recommends that the mounting position of the antenna be determined *after* testing and verifying optimal communication conditions.

⚠ CAUTION

When installing multiple FDP03TJ010/020 that will use different frequency groups in the same area, FDP03TJ010/020's antennas of different frequency groups must be mounted at least 6 feet (2 meters) apart. Failure to do so may severely reduce the modem operating range.

NOTE

Please contact Futaba for information about antenna separation when using the FDP03TJ010/020 and other wireless products in the same area.

II.III Environmental Safety Hazards and Notes

⚠ WARNING

If the FDP03TJ010/020 has been stored at a temperature beyond the specified operating temperature range for the system, it may not function properly. Allow it to return to normal temperatures before use. Refer to **APPENDIX A – TECHNICAL SPECIFICATIONS** for the actual operating temperature range.

⚠ WARNING

The FDP03TJ010/020 is a precision electronic device with a rugged design that is intended for industrial applications. However, do not install it where it will encounter excessive vibrations. In some cases, isolation mounts may be used to isolate the modem from the equipment's vibration. Excessive vibration can permanently damage the modem and/or cause it to malfunction.

⚠ WARNING

Do not operate the FDP03TJ010/020 in environments where it will be subjected to excessive moisture (such as rain or water spray), dust, oil, or other foreign matter (such as metal particles). Doing so may permanently damage the modem and/or cause it to malfunction. If it does become wet or contaminated, correct the situation, verify proper operation and have any problems corrected before using it to control other equipment. If necessary, the modem can be mounted inside a protective or waterproof enclosure. If the enclosure is metallic, the antenna must be mounted externally or the effective operating range will be severely limited.

⚠ WARNING

The FDP03TJ010/020 is designed for indoor use. When using it outdoors, the modem should be mounted in a waterproof enclosure and the ambient temperature range should be checked to insure that it is within the modem's specifications. Always use the modem within its specified environmental ranges.

II.IV Other Notice

NOTE

Italicized gothic word used in this manual shows functional and technical term especially important for the FDP03TJ010/020.

Operational Safety Hazards and Notes



Before each use of the FDP03TJ010/020, ensure that the area where the equipment will be operated is clear of people or obstacles that may affect its safe operation.



Before each use of the FDP03TJ010/020, verify that both the equipment being controlled and the modem are in proper operating condition.



When rewriting the FDP03TJ010/020's memory registers, do not turn the modem's power off. If the power is interrupted, the memory contents may be lost or corrupted and the modem operation will be unpredictable. If the memory contents are lost or corrupted, they may be restored to original initial settings by reinitializing them.



Do not attempt to operate remotely controlled equipment outside the communication range of the FDP03TJ010/020. Doing so could cause loss of control of the equipment.

III System Identification

For future reference, please take a moment to fill in the information below. This information will help us respond as quickly as possible should your FDP03TJ010/020 ever need repair or replacement.

Model Name and Number: FDP03TJ010/020

Serial Number: _____

Date of Purchase: _____

Distributor Name: _____

Distributor Address: _____

Distributor Phone Number: _____

IV Limited Warranty

FUTABA WARRANTS ONLY THAT THE INDUSTRIAL RADIO CONTROL SYSTEM GOODS OR PRODUCTS FURNISHED HERewith SHALL BE FREE FROM DEFECTS IN MATERIAL AND WORKMANSHIP UNDER NORMAL CONDITIONS OF USE AND SERVICE FOR A PERIOD OF ONE (1) YEAR FROM THE DATE OF SALE TO THE PURCHASER WHO IS THE FIRST BUYER OF THE GOODS FOR USE OR CONSUMPTION AND NOT FOR RESALE OTHER THAN AS A COMPONENT OF ANOTHER PRODUCT MANUFACTURED FOR SALE BY SUCH PURCHASER ("CONSUMER"). FUTABA'S LIABILITY, WHETHER BASED ON BREACH OF WARRANTY OR NEGLIGENCE, SHALL BE LIMITED, AT FUTABA'S ELECTION, TO REPLACEMENT OR REPAIR OF ANY SUCH NONCONFORMING GOODS, F.O.B. FUTABA'S U.S.A. PLANT, OR, AT FUTABA'S ELECTION, CREDIT FOR THE NET PURCHASE PRICE OF SUCH GOODS. ALL CLAIMS HEREUNDER MUST BE MADE IN WRITING DURING THE WARRANTY PERIOD, AND FUTABA SHALL HAVE THE RIGHT PRIOR TO ANY RETURN OF GOODS TO INSPECT ANY GOODS CLAIMED TO BE NONCONFORMING, AND IN ANY EVENT RESERVES THE RIGHT TO REJECT CLAIMS NOT COVERED BY WARRANTY. THIS LIMITED WARRANTY CONSTITUTES FUTABA'S SOLE WARRANTY. **FUTABA MAKES NO OTHER WARRANTY OF ANY KIND, EXPRESS OR IMPLIED, AND EXPRESSLY DISCLAIMS ANY IMPLIED WARRANTY OF MERCHANTABILITY OR FITNESS FOR A PARTICULAR PURPOSE.** FUTABA'S WARRANTY SHALL NOT APPLY IF, AMONG OTHER LIMITATIONS CONTAINED HEREIN OR FURNISHED WITH THE PRODUCT, BUYER, OR CONSUMER, OR ANY USER OF THE PRODUCT (A) ALTERS SUCH PRODUCT, OR (B) REPLACES ANY PART OF SUCH PRODUCT WITH ANY PART OR PARTS NOT FURNISHED BY FUTABA FOR THAT PURPOSE, OR IF, AMONG SUCH OTHER LIMITATIONS, PRODUCT FAILS TO OPERATE PROPERLY OR IS DAMAGED DUE TO ATTACHMENTS OR COMPONENTS THAT ARE NOT FURNISHED BY FUTABA FOR USE WITH OR REPAIR OF THE PRODUCT UNLESS SUCH USE IS AUTHORIZED IN WRITING IN ADVANCE BY FUTABA.

THIS LIMITED WARRANTY EXTENDS ONLY TO THE CONSUMER AND IS NOT ASSIGNABLE OR TRANSFERABLE. This limited warranty shall not apply to fuses, lamps, batteries, or other items that are expendable by nature, unless otherwise expressly provided.

This limited warranty does not cover any defect or damage to any of the goods caused by or attributable to force, accident, misuse, abuse, faulty installation, improper maintenance, improper electrical current, failure to install or operate in accordance with Futaba's written instructions, repair or alteration by unauthorized persons, or leaking batteries. **THE GOODS ARE SENSITIVE ELECTRONIC DEVICES REQUIRING SPECIAL HANDLING, AND THIS LIMITED WARRANTY DOES NOT APPLY TO PRODUCTS NOT HANDLED IN ACCORDANCE WITH INSTRUCTIONS SET FORTH IN THE MANUAL.**

THIS LIMITED WARRANTY DOES NOT COVER INDUSTRIAL RADIO CONTROL PRODUCTS PURCHASED OR USED OUTSIDE OF THE UNITED STATES WITHOUT FUTABA'S PRIOR APPROVAL.

V Returns

Futaba's authorization must be obtained prior to return of any item for warranty or other repair or replacement or credit and will reflect Futaba's warranty service procedure. Consumer's warranty rights are governed by the terms of Futaba's Limited Warranty, as above described. Products returned for warranty repair or replacement or credit must be carefully and securely packed for return, preferably in the original carton or equivalent. The Consumer must also include in the carton a legible copy of the bill of sale or invoice which shows the date of sale and the original Buyer's and Consumer's names, and also a letter which gives the Consumer's return address and contact telephone number, the model and serial numbers of the product(s) returned, and a brief explanation of the problem or claimed defect. Any returned products that are replaced by Futaba shall become the property of Futaba. If after inspection Futaba determines the defect is not covered by its limited warranty, Futaba will notify Consumer of its determination and will not undertake any repairs or product replacement until Consumer agrees to pay for all necessary parts and materials, labor (to be charged at Futaba's standard repair rate then in effect), and other expenses including all shipping charges and insurance. Futaba reserves the right to retain possession of any product returned by Consumer because of defects not covered by Futaba's warranty until Futaba receives Consumer's agreement as above noted or, if Consumer wants the product returned without repair or replacement, Consumer reimburses Futaba for all shipping and handling charges incurred by Futaba. Issuance of credit for returned items shall be made at Futaba's unfettered discretion. Consumer will not be entitled to return defective goods for cash refunds. Consumer must inspect goods immediately and no rejection or revocation of acceptance shall be permitted more than ten (10) days after delivery to, or first use by, Consumer of the goods, whichever occurs first.

VI Patents – Copyrights – Trademarks – Proprietary Rights

If this product was manufactured according to designs or processes specified by Consumer, Consumer shall indemnify and save Futaba, its affiliates, officers, agents, and employees, harmless from any expense, loss, attorneys' fees, costs, damages, or liability which may be incurred as a result of actual or alleged infringement of patent, copyright, or trademark rights. Furnishing of these products does not convey a license, implied or otherwise, under any patent, copyright, or trademark right in which Futaba has an interest, nor does it convey rights to trade secrets or any other proprietary information of Futaba.

VII Limitation of Damages and Action

IN NO EVENT SHALL FUTABA BE LIABLE TO CONSUMER, OR ANY OTHER PERSON FOR ANY INCIDENTAL, CONSEQUENTIAL, OR SPECIAL DAMAGES RESULTING FROM THE USE OF OR INABILITY TO USE THIS PRODUCT, WHETHER ARISING FROM BREACH OF WARRANTY OR NEGLIGENCE OF FUTABA, OR OTHERWISE. Any action hereunder must be commenced within one (1) year of accrual of cause of action or be barred and forever waived. No modification or alteration of Futaba's Limited Warranty or any other provision of this paragraph or the above paragraphs shall result from Futaba's acknowledgment of any purchase order, shipment of goods, or other affirmative action by Futaba toward performance following receipt of any purchase order, shipping order, or other form containing provisions, terms, or conditions in addition to or in conflict or inconsistent with any such provisions.

Contents

1. Overview	1
2. Operating Modes	1
2.1 Packet Transmission Mode.....	1
2.2 Headerless Packet Transmission Mode	4
2.3 Serial-Output Data Format of Receiver Side at The Transmission Mode	5
2.4 Broadcast Transmission Mode	6
3. Data Transfer	7
3.1. Data Transfer Mode.....	7
FDP03 has 2 kinds of data transfer mode. One is “Interchange” mode that is possible to exchange data between other FDP series. Another is “Communication Distance Extend” mode. The initial setting is “Interchange” mode.....	
The data transfer mode should be same setting among communication partners. If the mode is different each other, it is impossible to communicate with.....	7
3.2. Setting.....	7
3.2.1. Setting by the memory register	7
The data transfer mode can be changed by the bit 5 of the REG10. The initial setting of the bit 5 is “0”. It means that “Interchange” mode. For more detail, please check Section 8.	
3.2.2. Setting by command.....	7
The data transfer mode can also be changed by SPD command. For more detail, please check Section 9.3.	
7	
3.3. Difference of 2 modes	7
Interchange Mode.....	7
It is possible to communicate between other FDP series such as FDP01 and FDP02.....	
Communication Distance Extend Mode.....	7
Wireless communication distance is extended to twice as long as “Interchange” mode.....	
4. Transmission Timing.....	8
4.1 Transmission Timing.....	8
4.2 Time period of the case that data re-transmission of divided packet is occurred at packet transmission mode.....	12
5. Low Power Stand-by Mode.....	13
This mode realizes low power consumption drive by switching ON and Off of RF circuit. It is possible to set this low power stand-by mode by the memory register (REG21: bit 2) or the command. If this mode is set by the command, this mode is released by the main power OFF or by set to power down mode.	
5.1. Operation Flow	13
5.2. Setting	13
5.2.1. Setting by the memory register.....	13
5.2.2. Setting by the command	14
6. RF Circuit Power Control Mode	15
6.1. Operation Flow	15
8. Registers.....	17
8.1. List of Registers	17
8.2. Explanation of Registers	18
9. Frequency.....	27
9.1 Frequency Range.....	27
9.2 Frequency Setting and Frequency Group.....	28
9.3 Commands.....	29
9.3.1 List of commands.....	29
9.3.2 Command input format	29
9.3.3 Explanation of commands.....	30
10. Interface.....	47
10.1. Pin Layout	47

10.2.	Recommended Connector	47
10.3.	Electrical Characteristics.....	48
10.4.	AC Characteristics.....	48
10.4.2	Low Power Stand-by Mode.....	49
10.5.3.	RF Circuit Power Control Mode.....	50
10.5.4.	Power Down Mode.....	51
10.5.5.	Parameter Initializing by /SHUT and /INI Terminal	52
11.1.	Outer Dimensions.....	53
11.2.	Weight	53
11.3.	Power Supply	53
11.4.	Radio Specifications.....	54
10.5	Interface.....	54
10.6	Environment.....	54
11.	Notes.....	55
11.1	Data Communication Delay	55
11.1.1	Delay at the transmission side	55
11.1.2	Delay at the reception side	55
11.2	Reception of Same Packets	55
11.3	Timing of Command Input	55
11.4	Headerless Packet Transmission Mode	56
11.4.1	Input data.....	56
11.4.2	Measures against packet loss.....	56
11.5	Occurrence of Data Loss Even under Hardware Flow Control	56
11.6	Frequency Setting in Multi-System Environment	56
11.7	Timing of Command Input	56
11.8	INI and RST Commands	56
11.9	Power-Down Mode	56

1. Overview

The FDP03TJ010/020 (hereinafter referred to as the "FDP03") is a 2.4GHz-band wireless radio modem with a compact and low power consumption design. FDP03TJ010 should be connected to an external antenna by an antenna connector. FDP03TJ020 equips built-in antenna



Do NOT place FDP03TJ020 near any metal objects. Because FDP03TJ020 uses built-in antenna, RF radio will be blocked and will have unnecessary reflections if it is placed near metal objects.



Communication distance of FDP03TJ020 will be dramatically changed by the surrounding environment.

2. Operating Modes

The FDP03 has the following three transmission modes:

- Packet transmission mode
- Headerless packet transmission mode
- Broadcast transmission mode

2.1 Packet Transmission Mode

The FDP03 supports two types of wireless addresses. One is unique address and the other is group address. At packet transmission mode, data packets are transmitted to the unique address and/or group address through the serial port. AT this mode, the packet format should be text or binary data.

(1) Configuration of text packet

Command header	Command	Destination address	Data (message)	Delimiter
1 byte	3 bytes	3 bytes	0 to 130 bytes	2 bytes
@	TXT	000 to 255	User defined data	<Cr><Lf>

(2) Configuration of binary data packet

Command header	Command	Destination address	Number of data bytes	Data (message)	Delimiter
1 byte	3 bytes	3 bytes	3 bytes	0 to 130 bytes	2 bytes
@	TBN	000 to 255	000 to 130	User-specified defined data	<Cr><Lf>

Processing of packet transmission and reception

When a packet is input to a sender FDP03 via the serial port, the sender FDP03 checks whether the packet is valid.

Then, if the packet configuration is invalid or a time gap between bytes is more than 5 seconds, the sender FDP03 distinguishes an occurrence of a packet error and ignores the packet. At that time, the sender FDP03 notifies the occurrence of the packet error if the functions of "Enabling response" and "Enabling N0 response" in he REG13 are turned on.

If the functions of "Enabling response" and "Returning P1 and P0 responses" in the REG13 register are turned on, the sender FDP03 replies a P1 response to the host when it receives a valid packet data. However, the sender FDP03 does not return any response if the functions of the REG13 register is different setting. Then, the sender FDP03 transmits the packet through wireless transmission to the destination address, receiver FDP03.

At receiver FDP03 side, it output the packet data through the serial port if configurations of packet are valid.

At that time, the receiver FDP03 responds an acknowledgement “ACK” signal to the sender FDP03 for notifying data packet receiving if "Enabling destination address check at reception" function of the REG18 register is turned on. On the other hand, when the function of "Disabling destination address check at reception" in the REG18 register is turned on, the receiver FDP03 does not return ACK signal to the sender FDP03 and also it receives all packet data regardless of the destination address of the packet.

Packet data transmission from the sender to the receiver is finished when the sender FDP03 receives ACK signal. At that time, the sender FDP03 outputs P0 response if "Enabling response" functions of the REG13 register is turned on. When the sender FDP03 cannot receive ACK signal within the time-out limit, the sender FDP03 transmits the same packet data to the destination receiver through the air if the re-try frequency is registered. (The re-try frequency can be set by REG11 register

When the receiver FDP03 receives the same packet several times, it ignores from the second data downward. Also, the receiver FDP03 sends ACK signal to the sender FDP03 if the function of "Enabling destination address check at reception" of REG18 register is turned on.

If the sender FDP03 cannot receive ACK signal even it sent packet data defined times by the REG11 register, it outputs N1 response to the host device via the serial port when "Enabling response" function of REG13 register is turned on. No response signal is sent if the function of "Disabling response" in REG13 is turned on

The figure below shows an operation example of data packet communication between a sender FDP03 that the "Enabling response" and "Returning P0 and P1 responses" functions of REG13 register are turned on and a receiver FDP03 that "Enabling destination address check at reception" function of REG18 register is turned on. At the figure, data communication is completed by “ACK” signal retry.

- ① The Host 1 inputs data to the sender FDP03 via the serial port.
- ② The sender FDP03 recognizes the data packet configuration as valid and returns a P1 response to the Host 1 (Data is accepted).
- ③ The sender FDP03 transmits the data packet to the destination, which is the receiver FDP03, by wireless transmission.
- ④ The receiver FDP03 receives the packet and outputs the received data packet to the Host 2 via the serial port.
- ⑤ The receiver FDP03 returns ACK to the sender FDP03 by wireless transmission.
- ⑥ Time-out is occurred at the sender FDP03 because it cannot receive the receiver's ACK signal at the first transmission. The sender FDP03 re-sends the data packet transmission.
- ⑦ The receiver FDP03 receives the same data packet as the previously received one. Thus, the receiver FDP03 ignores the received data but returns ACK signal to the sender FDP03.
- ⑧ The sender FDP03 receives the ACK signal and outputs a P0 response to the Host 1.

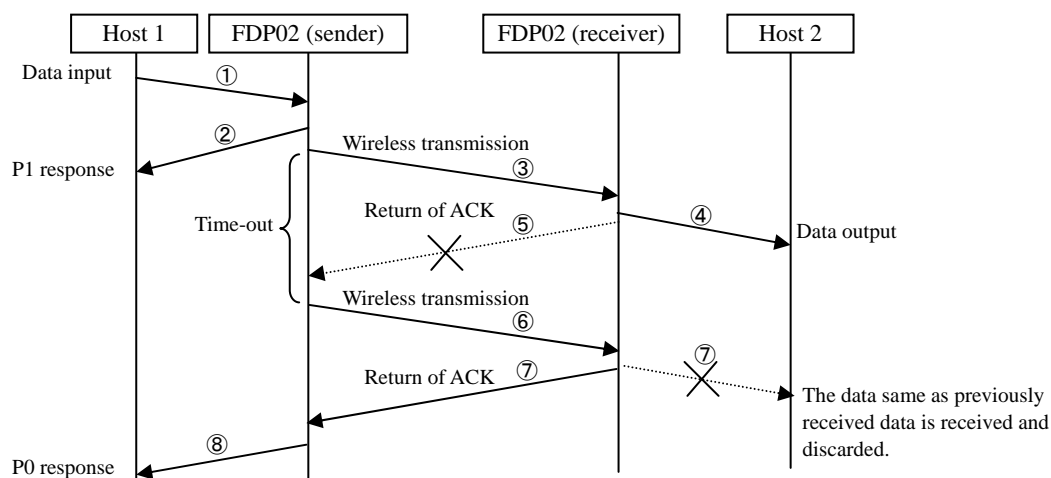

⚠ CAUTION

After entering a command to the sender FDP03, do not input the next command until the P0 response for the entered command is returned. Sending a new command before the P0 response is received, it may cause of command error and/or unpredictable operation.

When "Disabling response" function of REG13 register of the sender FDP03 is turned on, the next command should be input after waiting a time period of expected P0 response.

2.2 Headerless Packet Transmission Mode

By setting "Headerless packet transmission mode" on the REG03 register of the FDP03, the FDP03 transmits packets by wireless transmission to a destination address that is defined by the REG02 register. At this mode, a header part (command header "@", command "TXT" or "TBN", destination address, and number of message bytes [for TBN command]) can be eliminated. The trigger of data transmission can be defined by the setting of REG24 register. It can be selectable entering of "<Cr><Lf>" (0DH, 0AH) (i.e., carriage return and line feed codes) or time over of the timeout period (a time gap limit between two data bytes that is set in the REG26 register). Data transmission is triggered also when the number of message bytes exceeds 26 bytes. It is also enable to set "Enabling response" and "Disabling response" mode by the REG13 register at the headerless packet transmission mode. Additionally, "Returning P1 and P0 responses" and "Returning P0 response" function can be selected when "Enabling response" mode is chosen. Moreover, "Enabling destination address check at reception" and "Disabling destination address check at reception" function can be selected by the REG18 register. For more details, see section 2.1 "Packet transmission mode". Also, it is selectable whether "<Cr><Lf>" (0DH, 0AH) is added on the received data by the settings of the bit 4 of the REG23 register.

CAUTION

In headerless packet transmission mode, maximum data buffer size for sending data is 150 bytes and data transmission is started when message data size exceeds 26 bytes. When many message data are input consequently, the message buffer may be overflowed and the message data may be lost. At that situation, the hardware flow control function should be set. If "Enabling response" function is selected in REG13 register, it is possible to judge whether data transmission is succeeded or not. Thus it is recommended to set "Enabling response" function even in headerless packet mode.

Additionally, the message data may be lacked when the size is over 26 bytes. To prevent for such an event, check each response on the sender and create messages so that the loss of packets can be detected on the receiver FDP03.

NOTE

The serial communication speed of all FDP03 should be same setting. If different serial communication speeds are set between the sender and the receiver FDP03, data loss may occur on the slower speed side.

2.3 Serial-Output Data Format of Receiver Side at The Transmission Mode

Data format of the receiver side that outputs to the serial port varies depending on the transmission mode (packet transmission or headerless packet transmission mode). The below table shows combination of the data format and the mode setting.

Sender FDP03 (radio address is 000)		Receiver FDP03 (radio address is 001)	
Transmission mode	Packet format	Transmission mode	Serial-output data format
Packet transmission (text format)	@TXT001HELLO<Cr><Lf>	Packet transmission	RXT000HELLO<Cr><Lf>
Packet transmission (binary format)	@TBN001005HELLO<Cr><Lf>	Packet transmission	RBN000005HELLO<Cr><Lf>
Packet transmission (text format)	@TXT001HELLO<Cr><Lf>	Headerless*	HELLO
Packet transmission (binary format)	@TBN001005HELLO<Cr><Lf>	Headerless*	HELLO
Headerless packet transmission + <Cr><Lf>	HELLO<Cr><Lf>	Packet transmission	RBN000007HELLO<Cr><Lf><Cr><Lf>
Headerless packet transmission + time-out	HELLO	Packet transmission	RBN000005HELLO<Cr><Lf>
Headerless packet transmission + <Cr><Lf>	HELLO<Cr><Lf>	Headerless*	HELLO<Cr><Lf>
Headerless packet transmission + time-out	HELLO	Headerless*	HELLO

* If "Adding '<Cr><Lf>' to received data" function of the receiver FDP03 is turned on by the bit 4 of REG23 (setting value is 1) at the headerless transmission mode, "<Cr><Lf>" is added at the end of the data that is output to serial port.

2.4 Broadcast Transmission Mode

It is possible to send data by broadcast transmission. Broadcast transmission mode can be used by setting the destination address to "255" at packet transmission or headerless packet.

In broadcast transmission mode, the sender FDP03 transmits data packet defined times by REG11 register + 1 time. If "Enabling response" function is turned on, the sender FDP03 sends response signal to the host. For more details, see the section 2.1.

At broadcast transmission mode, the receiver FDP03 does not return ACK signal regardless of the REG18 register setting. Also, when the receiver FDP03 receives redundant data packet, it ignores duplicated packets .

The below figure shows the data flow of broadcast transmission mode that "Enabling response" and "Returning P0 and P1 responses" functions of the sender FDP03 is turned on.

- ① Host 1 inputs broadcast data to the sender FDP03.
- ② The sender FDP03 recognized the data packet configuration is valid and returns a P1 response to the host 1 (data is accepted).
- ③ The sender FDP03 broadcasts data packet defined times by REG11 register + 1 by air .
- ④ When the receiver FDP03 receives the packet correctly, it outputs the received data packet to the host 2 via the serial port.
- ⑤ When the sender FDP03 completes all data transmission, it outputs a P0 response to the host 1.

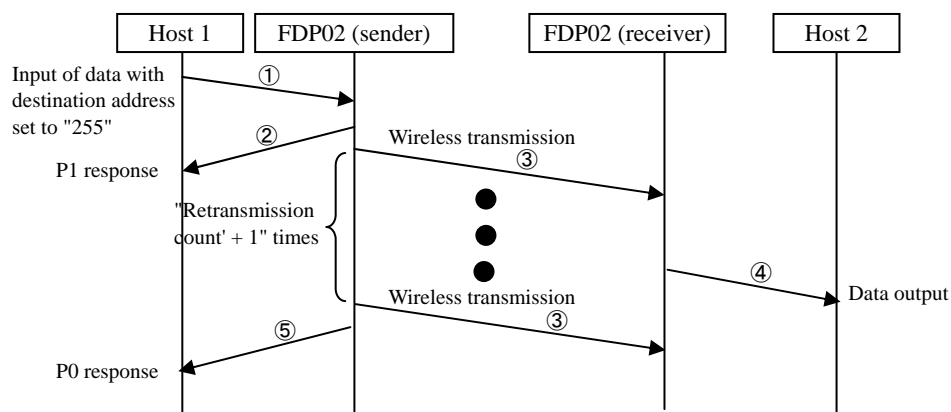

3. Data Transfer

3.1. Data Transfer Mode

FDP03 has 2 kinds of data transfer mode. One is “Interchange” mode that is possible to exchange data between other FDP series. Another is “Communication Distance Extend” mode. The initial setting is “Interchange” mode.

NOTE

The data transfer mode should be same setting among communication partners. If the mode is different each other, it is impossible to communicate with.

3.2. Setting

3.2.1. Setting by the memory register

The data transfer mode can be changed by the bit 5 of the REG10. The initial setting of the bit 5 is “0”. It means that “Interchange” mode. For more detail, please check Section 8.

3.2.2. Setting by command

The data transfer mode can also be changed by SPD command. For more detail, please check Section 9.3.

3.3. Difference of 2 modes

Interchange Mode	It is possible to communicate between other FDP series such as FDP01 and FDP02.
Communication Distance Extend Mode	Wireless communication distance is extended to twice as long as “Interchange” mode.

4. Transmission Timing

4.1 Transmission Timing

At packet transmission mode, the FDP03 can transmit up to 130 bytes of message as a single packet. However, the radio transmission unit of the data is divided by 26 bytes. Since the FDP03 internally divides a message by 26 bytes when the packet size is bigger than 26 bytes, total data transmission time is varies with the data size. -

In headerless packet transmission mode, the FDP03 transmits each message in units of 26 bytes without dividing them.

The time required for communication is shown below.

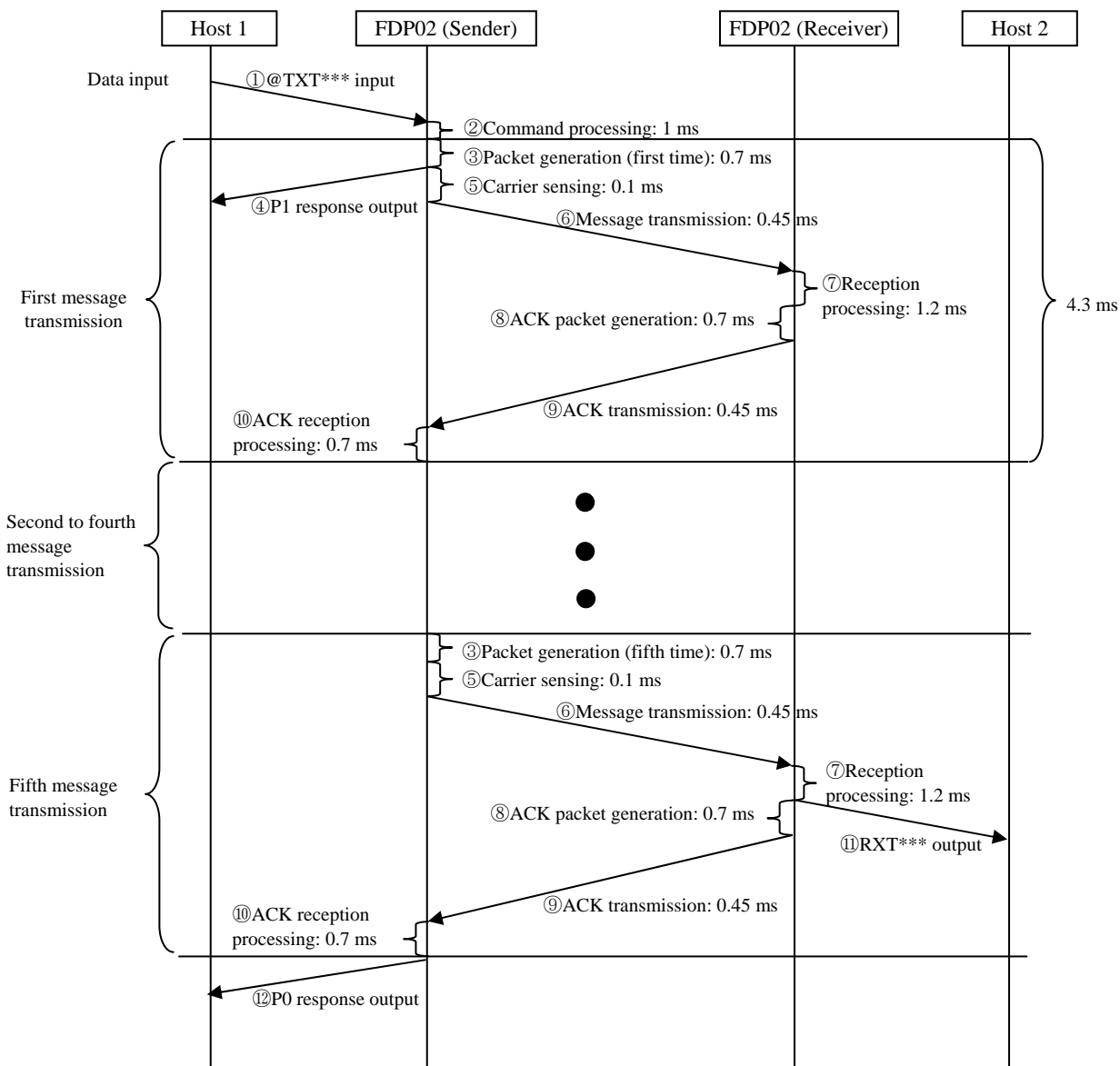

① Serial input of transmission data packet

The time required to data input between the host1 and the sender FDP03 is defined by below communication parameter.

- Line speed (9,600 to 115,200 bps)
- Data bit length (7 or 8 bits)
- Parity bit (odd, even, or no parity)
- Stop bit length (1 or 2 bits)
- Start bit length (always 1 bit)

For example, data transmission time is 87us when the line speed is 115,200bps, the data bit length is 8 bits, the parity bit is NONE, the stop bit length is 1 and the start bit length is 1. (Time of data transmission for 1 bit is 8.7us and 1byte is 10bits.)

If the transmission is text data at the packet transmission mode, size of send data packet is message bytes + 9 bytes because the header is 7 bytes and delimiter is 2 bytes.

If the transmission is binary data at the packet transmission mode, size of send data packet is message bytes + 12 bytes because the header is 10 bytes and delimiter is 2 bytes.

At the headerless packet mode, the data size is message bytes + 2 bytes if delimiter is included. On the other hand, if the trigger of transmission is “time-out”, the data size is the same as the message size. However, the data transmission time is defined by “time-out” setting by REG24 and REG26 register.

② Command processing

It is the time for internal processing of receiving and decoding the packet that comes from the serial port. It takes 1.5 ms.

③ Transmission packet generation

It is the time for transmission data packet generation. It takes 1.0 ms.

④ Response of input data format acceptance

It is the time for response when the receiving data format is valid. The length is 4 bytes. It depends on the parameters of ①.

⑤ Carrier sensing

It is the time for detection whether other radio station uses same frequency band. If other radio station uses the frequency band, the sender FDP03 does not transmits the data. It takes 0.1 ms.

NOTE

If the wireless environment is very severe, noise level is very high and/or other wireless systems occupy the area, the sender FDP03 may be not able to transmit any data because of carrier sensing.

⑥ Message transmission

It is the time for data transmission and it takes 0.45 ms.

⑦ Data reception processing

It is the time for the receiving data processing and it takes 2.4 ms.

- ⑧ ACK packet generation
It is time for ACK packet generation. It takes 1.0 ms
- ⑨ ACK packet transmission
It is time for ACK packet transmission that the acknowledgement of data packet reception. It takes 0.45 ms.
- ⑩ ACK reception processing
It is processing time for ACK packet. It takes 1.0ms.
- ⑪ Serial output of received packet
It is time for output of received data packet to the host 2 through the serial port. The time period depends on the communication setting between the host 2 and the receiver FDP03.

If the transmission is text data at the packet transmission mode, size of output data packet is message bytes + 8 bytes because the header is 6 bytes and delimiter is 2 bytes. If the transmission is binary data at the packet transmission mode, size of send data packet is message bytes + 11 bytes because the header is 9 bytes and delimiter is 2 bytes.

At the headerless packet mode, the data size is message bytes + 2 bytes if delimiter is included. On the other hand, if the trigger of transmission is “time-out”, the data size is the same as the message size. If "Adding '<Cr><Lf>' to received data" function of the receiver FDP03 is turned on by the bit 4 of REG23 (setting value is 1) at the headerless transmission mode, "<Cr><Lf>" is added at the end of the data and it consume 2 bytes.

- ⑫ Indication of data transmit completion
A response is returned to the host 1 when the data transmission is completed correctly. The length of response data is 4 bytes, and the time period of response return depends on the parameter settings of the communication parameters that are described in above section ①.

Based on the above data processing flow, the total time for the data packet transmission from the host 1 to the host 2 can be calculated like below. (In the below calculation, no data packet re-transmission is supposed.)

$$\frac{\text{Bit length per byte}}{\text{Line speed of the sender}} \times 1000 \times (\text{size of message in bytes} + A) + B + 6.4 \times (C - 1) \\ + \frac{\text{Bit length per byte}}{\text{Line speed of the receiver}} \times 1000 \times (\text{size of message in bytes} + D) + 5.5 \text{ [ms]} \quad \text{Expression 1}$$

A:	Text data is transmitted at packet transmission mode:	9
	Binary data is transmitted at packet transmission mode:	12
	Trigger of the data transmission is delimiter at headerless packet transmission mode:	2
	Trigger of the data transmission is time-out at headerless packet transmission mode:	0
B:	Trigger of the data transmission is time-out at headerless packet transmission mode:	"Value of REG26" x 10 [If the bit 0 of REG24 is "1"] "Value of REG26" x 1 [If the bit 0 of REG24 is "0"] (*1)
	Others:	0
C:	Data size of message is 0 to 26 bytes:	1 (*2)
	Data size of message is 27 to 52 bytes:	2
	Data size of message is 53 to 78 bytes:	3
	Data size of message is 79 to 104 bytes:	4
	Data size of message is 105 to 103 bytes:	5
D:	Text data is transmitted in packet transmission mode:	8
	Binary data is transmitted in packet transmission mode:	11

Trigger of the data transmission is delimiter at headerless packet transmission mode: 2
 Trigger of the data transmission is time-out at headerless packet transmission mode: 0

- *1 If the setting value is less than 3ms, the value of “B” will be “3”.
- *2 At headerless packet mode, the value of C is always 1.

The total time until completion of the data transmission is calculated by below formula.

$$\frac{\text{Bit length per byte}}{\text{Line speed of the sender}} \times 1000 \times (\text{size of message in bytes} + A + 4) + B + 6.4 \times C + 1.5 \quad \text{Expression 2}$$

A: Text data is transmitted at packet transmission mode: 9
 Binary data is transmitted at packet transmission mode: 12
 Trigger of the data transmission is delimiter at headerless packet transmission mode: 2
 Trigger of the data transmission is time-out at headerless packet transmission mode: 0
 B: Trigger of the data transmission is time-out at headerless packet transmission mode:
 "Value of REG26" x 10 [If the bit 0 of REG24 is "1"]
 "Value of REG26" x 1 [If the bit 0 of REG24 is "0"] (*1)
 Others: 0
 C: Data size of message is 0 to 26 bytes: 1 (*2)
 Data size of message is 27 to 52 bytes: 2
 Data size of message is 53 to 78 bytes: 3
 Data size of message is 79 to 104 bytes: 4
 Data size of message is 105 to 103 bytes: 5

- *1 If the setting value is less than 3ms, the value of “B” will be “3”.
- *2 At headerless packet mode, the value of C is always 1.

4.2 Time period of the case that data re-transmission of divided packet is occurred at packet transmission mode

When packet data size is exceeding 26 bytes, it is divided into several packets that data size is 26 bytes. At that time, each divided packet is sent defined re-transmission times. Thus, maximum data transmission period will be (setting of REG11 register + 1) x 5 times. (REG11 register is a parameter of data re-transmission frequency.)

It takes 7.6 ms if data transmission failure is occurred once. Therefore, total data processing time is like below formula.

$$\frac{\text{Bit length per byte}}{\text{Line speed of the sender}} \times 1000 \times (\text{size of message in bytes} + A + 4) + B + 7.6$$

× frequency of data transmission Expression 3

A: Text data is transmitted at packet transmission mode:	9	
Binary data is transmitted at packet transmission mode:	12	
Trigger of the data transmission is delimiter at headerless packet transmission mode:		2
Trigger of the data transmission is time-out at headerless packet transmission mode:		0
B: Trigger of the data transmission is time-out at headerless packet transmission mode:		
	"Value of REG26" x 10	[If the bit 0 of REG24 is "1"]
	"Value of REG26" x 1	[If the bit 0 of REG24 is "0"] (*)
Others:		0

* If the setting value is less than 3ms, the value of "B" will be "3".

NOTE

In this case, if data transmission failure is occurred in any given divided packet, following packets are not transmitted. Therefore, total data transmission period is fluctuated.

Example 1: At the line speed set to 115,200 bps and bit length per byte set to 10 bits, time period of the data transmission failure detection is 53.1 ms if the first packet data is fail to transmit. (Size of the message is 130 bytes. Setting of data re-transmission frequency is 10 times.)

$$(10/115,200) \times 1,000 \times (130 + 9 + 4) + 7.6 \times (10+1) \times 1 = 96.0 \text{ [ms]}$$

Example 2: At the line speed set to 115,200 bps and bit length per byte set to 10 bits, time period of the data transmission failure detection is 215.9 ms if the fifth packet data is fail to transmit. (Size of the message is 130 bytes. Setting of data re-transmission frequency is 10 times.)

$$(10/115,200) \times 1,000 \times (130 + 9 + 4) + 7.6 \times (10 + 1) \times 5 = 430.4 \text{ [ms]}$$

As shown above, the total transmission time is largely fluctuated by the condition of the data transmission. To keep communication response well, size of the message should be less than 26 bytes.

5. Low Power Stand-by Mode

This mode realizes low power consumption drive by switching ON and Off of RF circuit. It is possible to set this low power stand-by mode by the memory register (REG21: bit 2) or the command. If this mode is set by the command, this mode is released by the main power OFF or by set to power down mode.

5.1. Operation Flow

By repeating “stand-by mode” and “sleep mode”, the power consumption at the RF circuit is reduced. Duration of the “stand-by mode” and “sleep mode” can be set by REG22, bit 1 of REG24 and REG25.

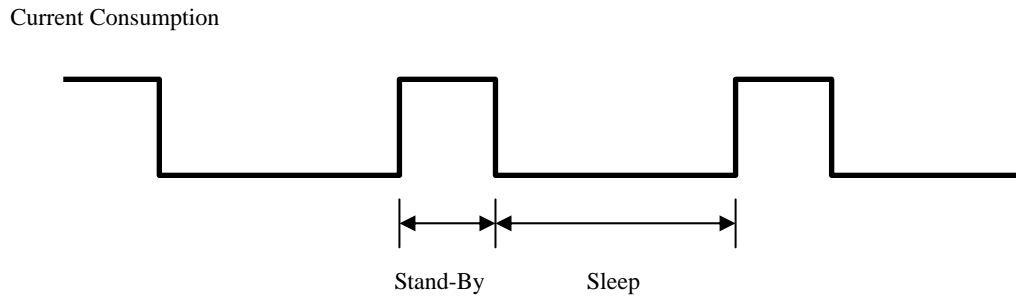

If the FDP03 receives data that destination address is matched and REG18 (address check) is set to “Enabling destination address check at reception”, the duration of the “stand-by mode” is extended. The extended time duration is set by REG21 or command setting. When the FDP03 cannot receive next data packet during the extended stand-by time, it becomes “sleep mode”.

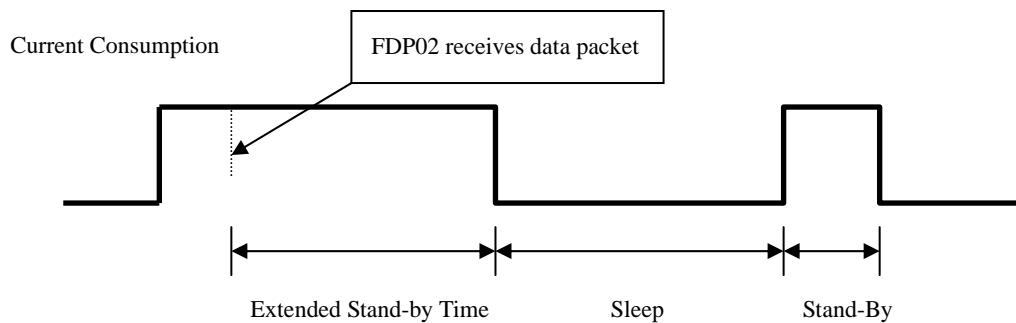

NOTE

If the data packet is sent by broadcasting mode and/or the REG18 setting is “Disabling group address check at reception”, the FDP03 does not turn to the “Extended Stand-by mode” even if the extended time duration is set by REG21.

5.2. Setting

5.2.1. Setting by the memory register

It is possible to set “Low Power Stand-by Mode” by bit 2 of REG21. At that time, time duration of “Stand-by” is set by REG22, that of “Sleep” is set by bit 1 of REG24 and REG25 and that of “Extended Stand-by Time” is set by bit 4 to 7 of REG21. For more detail, please check “Registers” section below.

5.2.2. Setting by the command

It is also possible to set “Low Power Stand-by Mode” by below listed commands. For mode detail, please check “Commands” section below.

Command	Function
POF	Turn off the Low Power Stand-by Mode
PON	Turn on the Low Power Stand-by Mode
PTE	Show/Set Extended Stand-by mode time duration
PTN	Show/Set time duration of Stand-by mode
PTS	Show/Set time duration of Sleep mode

6. RF Circuit Power Control Mode

This mode can realize low power consumption operation by stopping RF circuit.

6.1. Operation Flow

It is possible to control ON/OFF of RF circuit by ROF/RON command. For more detail of ROF/RON command, please check “Commands” section below.

Current Consumption

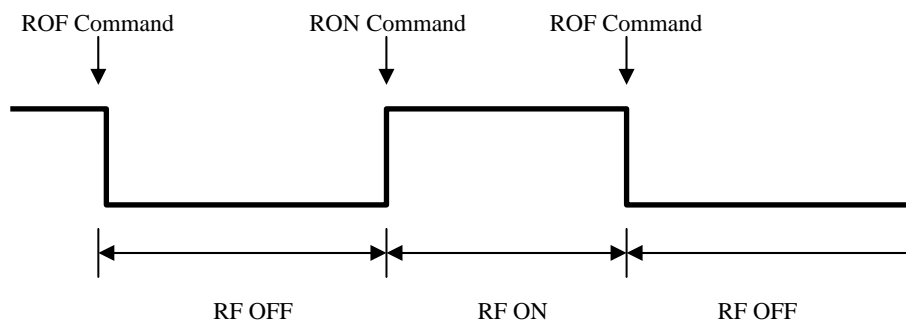

CAUTION

Wireless communication is completely cut when RF circuit is OFF. Therefore, RON command should be executed to turn ON the RF circuit if wireless communication is returned.

NOTE

If the FDP03 is re-booted and/or the operation mode is returned from “Power Down” mode, the RF circuit will be turned ON. Thus, it is necessary to execute ROF command to cut the RF circuit again.

7. Power Down Mode

If the voltage level of the /SHUT terminal is set to “Low” level, the power source of the FDP03 is cut and it becomes to “Power Down Mode”. During the “power Down Mode”, all functions of FDP03 does not work. When the voltage level of the /SHUT terminal is set to “High” level, the FRP02 is to be the operation mode.

Current Consumption

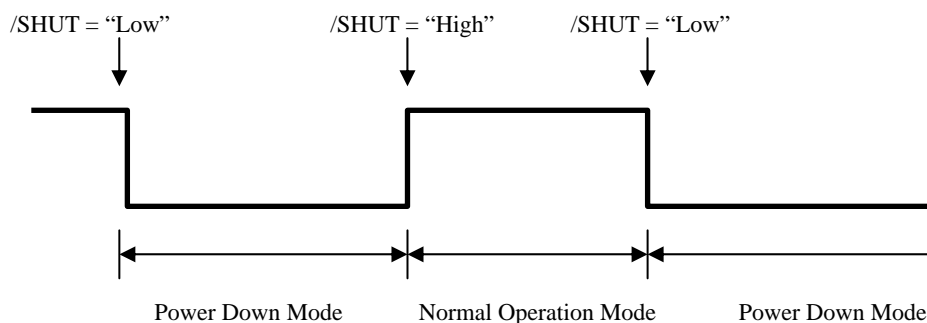

Do NOT set “Power Down Mode” during the FDP03 is accessing the memory registers. If the voltage level of the /SHUT terminal is turned to “Low” level, the settings of the memory registers are vanished. Therefore, do NOT touch the /SHUT terminal during REG commands are running.



The parameters that are set by REG commands are cleared when the operation mode is changed from the “Power Down Mode” to “Normal Operation Mode”. Thus, the parameters should be set by the memory registers.



Do NOT input any data to the signal line during the Power Down mode. The FDP03 will get damage if data are input during the Power Down mode. Also, do NOT input high impedance signal to the terminals of the host to avoid unnecessary data output.

8. Registers

All settings of the FDP03 are stored in its registers.

8.1. List of Registers

Below table shows list of all registers.

Register	Function	Default	Setting range	Remarks
REG00	Local station address	00H	00H to EFH	000 to 239
REG01	Group address	F0H	F0H to FEH	240 to 254
REG02	Destination address of Headerless-packet	00H	00H to FFH	000 to 255 (to be used for headerless packet transmission)
REG03	Transmission mode	F0H	F0H, FFH	Default: Packet transmission mode
REG04	ID code 1	00H	00H to FFH	
REG05	ID code 2	00H	00H to FFH	
REG06	Frequency group	03H	01H to 03H	Default: 3-band mode
REG07	Frequency 1	02H	02H to 4DH	Default: 2,402 MHz
REG08	Frequency 2	2AH	02H to 4DH	Default: 2,442 MHz
REG09	Frequency 3	4DH	02H to 4DH	Default: 2,477 MHz
REG10	Data transfer	01H	01H, 21H	Default: Interchange mode
REG11	Retransmission frequency	0AH	00H to FFH	Default: 10 times
REG12	Unused	00H	-	
REG13	Serial response of sent data	00H	00H to 07H	Default: "Returning P0 and P1 responses," "Enabling N0 response," and "Enabling response"
REG14	Unused	00H	-	
REG15	Command recognition interval	00H	00H to FFH	Default: 0 ms (to be used for headerless packet transmission)
REG16	Unused	00H	-	
REG17	Buffer clear	64H	01H to FFH	Default: 10s
REG18	Address check	8DH	8CH, 8DH	Default: "Enabling destination address check at reception"
REG19	Unused	00H	-	
REG20	Wired-communication setting 1 (serial communication)	00H	00H to FFH	Default: 9,600 bps, 8 data bits, no parity, and 1 stop bit
REG21	Wired-communication setting 2 (flow control), Low power stand-by mode, Extended stand-by time	09H	00H to FFH	Default: "Disabling hardware flow control" Without low power stand-by mode Extended stand-by time is Zero
REG22	Low power stand-by time	04H	01H to FFH-	Default: 40ms
REG23	Wired-communication setting 3	00H	00H, 10H	Default: "Not adding '<Cr><Lf>' to received data" (to be used for headerless packet transmission)
REG24	Delimiter for headerless-packet transmission Unit of sleep time duration	C1H	80H to 83H C0H to C4H	Default: <Cr><Lf> (to be used for headerless packet transmission) x 10ms
REG25	Sleep time	04H	01H to FFH	Default: 40ms
REG26	Time-out of headerless-packet data input	01H	01H to FFH	Default: 10 ms (to be used for headerless packet transmission)

* To initialize the registers, use the INI command (see Section 8.3.3) or input an initialization signal from the /INI pin (see Section 9.1).

8.2 Explanation of Registers

REG00 (local station address) [Default: 00H]

This register can set own wireless address. When the FDP03 receives a packet that destination is this address, the FDP03 processes the packet. The setting range is 00H to EFH (000 to 239). If the value is set to invalid range, the FDP03 returns N0 response.

REG01 (group address) [Default: F0H]

This is the wireless group address of the FDP03. When the FDP03 receives a packet that group is this address, the FDP03 processes the packet.

If "Enabling destination address check at reception" function of the REG18 is turned on, the FDP03 returns ACK signal to sender FDP03 when it receives a packet. Therefore, if "Enabling destination address check at reception" function of all FDP03 in the system is turned on, all FDP03 that receive a packet return ACK signal. Thus, to avoid unnecessary communication, the REG18 may be set to "Disabling destination address check at reception".

The range of the setting value is F0H to FEH (240 to 254). If the value is set to invalid range, the FDP03 returns N0 response.

REG02 (headerless-packet destination address) (only for the headerless packet transmission mode) [Default: 00H]

This register indicates the destination address of packet data in headerless packet transmission mode. This register also indicates the wireless address of the connection destination when TS2 command is used. The range of the setting value is 00H to FFH (000 to 255). If the value is set to invalid range, the FDP03 returns N0 response.

REG03 (transmission mode) [Default: F0H]

This register setting can change the transmission mode, which is packet transmission mode or headerless packet transmission mode.

F0H	Packet transmission mode (default)
FFH	Headerless packet transmission mode

The value of the setting is F0H (packet transmission mode) or FFH (headerless packet transmission mode). If the value is set to invalid range, the FDP03 returns N0 response.

REG04 (ID code 1) [Default: 00H]

This register setting defines data scramble ID. Combined with ID code 2 (REG05), variation of data scramble ID is up to 65,536.

Range of the setting value is 00H to FFH and FDP03 returns N0 response if the value is out of the range.

NOTE

The same scramble code (REG04 and REG05) must be set on all the FDP03s in the system. If the scramble codes are different each other, each FDP03 cannot communicate with.

REG05 (ID code 2) [Default: 00H]

This register setting defines data scramble ID. Combined with ID code 1 (REG04), variation of data scramble ID is up to 65,536.

Range of the setting value is 00H to FFH and FDP03 returns N0 response if the value is out of the range.

NOTE

The same scramble code (REG04 and REG05) must be set on all the FDP03s in the system. If the scramble codes are different each other, each FDP03 cannot communicate with.

REG06 (frequency group) [Default: 03H]

This register defines the number of frequencies to be used.

01H	Use only the frequency set by REG07
02H	Use the frequencies set by REG07 and REG08
03H	Use the frequencies set by REG07 to REG09 (default)

The range of settings is 01H to 03H.

When the register is set to 01H, only a frequency that is set by REG07 is used.

When the register is set to 02H, two frequencies that are set by REG07 and REG08 are used as a frequency group.

When the register is set to 03H, three frequencies that are set by REG07 to REG09 are used as a frequency group.

FDP03 returns N0 response if the value is out of the range.

NOTE

The setting value of REG07, REG08 and REG09 should not be duplicated when the setting of REG06 is “02H” and “03H”. If the frequencies have duplication, the transmission frequency will not be switched.

REG07 (frequency 1) [Default: 02H]

This register defines the frequency channel to be used for radio communication. The frequency channel that is set by this register is always used.

The range of the setting is 2,402 MHz to 2,477 MHz. It is possible to set it by both 2-digital hexadecimal value (02H to 4DH) and 3-digit decimal value (002 to 077). For more details of correspondence between setting values and frequency channels, please refer section 5.1. FDP03 returns N0 response if the value is out of the range.

REG08 (frequency 2) [Default: 2AH]

This register defines the frequency channel to be used for radio communication. The frequency channel that is set by this register is applied when the RGE06 setting is 02H or 03H.

The range of the setting is 2,402 MHz to 2477 MHz. It is possible to set it by both 2-digital hexadecimal value (02H to 4DH) and 3-digit decimal value (002 to 077). For more details of correspondence between setting values and frequency channels, please refer section 5.1. FDP03 returns N0 response if the value is out of the range.

REG09 (frequency 3) [Default: 4DH]

This register defines the frequency channel to be used for radio communication. The frequency channel that is set by this register is applied only if the RGE06 setting is 03H.

The range of the setting is 2,402 MHz to 2477 MHz. It is possible to set it by both 2-digit hexadecimal value (02H to 4DH) and 3-digit decimal value (002 to 077). For more details of correspondence between setting values and frequency channels, please refer section 5.1. FDP03 returns N0 response if the value is out of the range.

REG10 (Data Transfer) [Default: 01H]

Bit 7 and 6: Not used

Bit 5: Data transfer mode

0	Interchange mode (default)
1	Communication Distance Extend mode

NOTE

The data transfer mode should be same setting among communication partners. If the mode is different each other, it is impossible to communicate with.

Bit 4 to 0: Not used

REG11 (retransmission count) [Default: 0AH]

This register defines the maximum frequency of data packet retransmission.

When the sender FDP03 cannot receive ACK signal from the receiver FDP03, it retransmits the data packet "'defined value of this register' +1" times.

At broadcast transmission mode, the sender FDP03 always sends the data packet "'defined value of this register' +1" times.

The enable setting range of this register is 00H to FFH (0 to 255 times). FDP03 returns N0 response if the value is out of the range.

REG12 (unused) [Default: 00H]

This register is not used. It should be default setting "00H".

REG13 (Serial response to packet input)

[Default: 00H]

This register defines the responses for in-coming data packet from the host through the serial port.

Bits 7 to 3: Not used

Bit 2: N0 response

0	Enabling N0 response (default)
1	Disabling N0 response

Bit 2 is available only if the bit 0 is set to "Enabling response."

If this bit is set to "0" (Enabling N0 response), the FDP03 sends N0 response to the host through the serial port when the packet data format from the host is invalid or time gap between bytes is more than 5 seconds.

If this bit is set to "1", the FDP03 does not send any N0 response to the host

NOTE

When the bit2 of REG13 is set to "1", the FDP03 does not send any response even if the packet format is invalid.

Bit 1: Normal response

0	Returning P0 and P1 responses (default)
1	Returning P0 response

Bit 1 is available only if the bit 0 is set to "Enabling response." By this setting, it is possible to select type of response when the data packet configuration is valid.

If the bit 1 is set to "0", the FDP03 sends P1 response to the host through the serial port when it receives a data packet. Also, it sends P0 response to the host when the data transmission to the receiver is success.

When the data transmission to the receiver is failed, the FDP03 sends N1 response to the host.

If the bit 1 is set to "1", the FDP03 sends P0 response to the host through the serial port when the data transmission to the receiver is success and sends N1 response when the data transmission to the receiver is failed.

Bit 0: Enabling response

0	Enabling response (default)
1	Disabling response

The bit 0 is defines whether the FDP03 send a response to the host or not.

When bit 0 is set to 0, the FDP03 sends particular specified responses to the host through the serial port.

When bit 0 is set to 1, the FDP03 does not send any response to the host.

NOTE

When the 0 is set to "1", the FDP03 does not send any response even if the packet configuration is invalid.

NOTE

During the register setting, the FDP03 always sends the responses if it is any settings.

REG14 (unused) [Default: 00H]

This register is not used. It should be default setting “00H”.

REG15 (command recognition interval) (only for the headerless packet transmission mode) [Default: 00H]

If the packet to be transmitted in headerless packet transmission mode includes code "40H", which indicates the command header (@), the data following the code is handled as a command, and the packet cannot be transmitted normally. This register is used to avoid such problems. Code "40H" is handled as the command header only when the code is input after a time gap between bytes that exceeds the value set in this register.

The range of settings is 00H to FFH. The value is in units of 100 ms.

With the default setting (00H) of this register, code "40H" is always handled as the command header.

REG16 (unused) [Default: 00H]

This register is not used. It should be default setting “00H”.

REG17 (unused) [Default: 64H]

This register is not used. It should be default setting “00H”

REG18 (address check) [Default: 8FH]

Bits 7 to 2: Not used

Bit 1: Group address check

0	Disabling group address check at reception
1	Enabling group address check at reception (default)

Only if the bit 0 of REG18 is 0, the bit 1 is available.

When the bit 1 is set to “0”, the FDP03 receives all data packets whatever the destination address of the data packet is. On the other hand, the FDP03 only receives the data packets that destination address is consistent.

The FDP03 does not return ACK signal to the senders at both settings.

Bit 0: Destination address check

0	Disabling destination address check at reception
1	Enabling destination address check at reception (default)

When the bit 0 is set to 0, the FDP03 receives all data packets whatever the destination address of the data packet is. At this setting, the FDP03 does not send back any ACK signal.

When the bit 0 is set to 1, the FDP03 checks the destination addresses of data packets and receives only if the destination address is consists with its wireless address. At this setting, the FDP03 returns ACK signal to the host.

REG19 (unused) [Default: 00H]

This register is not used. It should be default setting “00H”.

REG20 (wired-communication setting 1) (serial communication) [Default: 00H]

Bit 7: Data length

0	8 bits (default)
1	7 bits

Bit 6: Enabling parity

0	No parity (default)
1	Using parity

Bit 5: Type of parity

0	Even parity (default)
1	Odd parity

Bit 4: Stop bit

0	1 bit (default)
1	2 bits

Bits 3 and 2: Not used

Bits 1 and 0: Baud rate

Bit 1	Bit 0	Baud rate
0	0	9,600 bps (default)
0	1	19,200 bps
1	0	38,400 bps
1	1	115,200 bps

REG21 (wired-communication setting 2[flow control], low power stand-by mode, extended stand-by time)
 [Default: 09H]

Bits 7 to 4: Extended Stand-by time

Bit 7	Bit 6	Bit5	Bit4	Extended Stand-by time
0	0	0	0	0 (0x20): Default
0	0	0	1	20ms (1x20)
0	0	1	0	40ms (2x20)
			.	
			.	
			.	
1	1	1	0	280ms (14x20)
1	1	1	1	300ms (15x20)

When the FDP03 receives data packet that destination address is matched at the setting of the REG18 is “Enabling destination address check at reception”, the time duration of the Stand-by mode is extended. If the data packet is set by broadcasting mode and/or the setting of the REG18 is “Disabling group address check at reception”, the time duration of the Stand-by mode is NOT extended. When “Extended Stand-by time” is set to 0ms, the FDP03 becomes “Sleep” mode right after it sends back ACK packet.

Bit 3: No used

Bit 2: Low power stand-by mode

0	Normal Operation Mode (Default)
1	Low Power Stand-by Mode

By setting “1” for the bit 2 of REG21 and re-booting the FDP03, operation mode becomes “Low power stand-by mode”. It is also turned “low power operation mode” after returning from the “Power down mode”. Time duration of the Stand-by and sleep mode are set by REG22 and REG25, respectively.

Bit 1: Hardware flow control

0	Disabling hardware flow control (default)
1	Enabling hardware flow control

This register can define validity of hardware flow control. If hardware flow control is enabled, the setting of the FDP03 should be same as that of the external device that connected to the FDP03. On the FDP03, make the same setting of this register as the flow control setting on the external equipment connected to the FDP03.

Hardware flow control is available by connecting control cables to the RTS and CTS pins.



Data flow may not stop immediately right after the hardware flow control vans the data flow if the software is written by PC. In such a case, some data from the PC may be lost.

Bit 0: Not used

REG22 (Low power stand-by time) [Default: 04H]

This register can define time duration of low power stand-by mode. The available setting value is 1 (10ms) to 255 (2550ms). Default value is 4 (40ms).



“Low power stand-by time” should be longer than 30ms when 2 frequency channel mode is used. Also, it should be longer than 40ms when 3 frequency channel mode is used.



When “Re-transmission count” (REG11) is large, data communication is sometimes failed. Especially, if the data message is divided into some packets, possibility of communication failure increases.

REG23 (wired-communication setting 3) (only for the headerless packet transmission mode) [Default: 00H]

Bits 7 to 5: Not used

Bit 4: Enable addition of <Cr><Lf> to the received data

0	Not add '<Cr><Lf>' to the received data (default)
1	Add '<Cr><Lf>' to the received data

This register defines availability of "<Cr><Lf>" (carriage return and line feed codes) addition to the end of the received data when the setting value of REG03 is “FFH”.

Bits 3 to 0: Not used

REG24 (delimiter for headerless-packet transmission, Unit of sleep time duration) [Default: C1H]

Bit 7: Not used

Bit 6: Delimiter

0	Time-out
1	<Cr><Lf> (default)

This bit of the register defines the trigger of data transmission when the setting value of REG03 is “FFH”. When the value of the bit 0 is “0”, the FDP03 starts transmission if no data packet is coming during specific time that is defined by REG26.

Bits 5 to 2: Not used

Bit 1: Unit of sleep time duration

0	x 10ms (Default)
1	x 100ms

Bit 0: Unit of time-out time

0	x 1 ms
1	x 10 ms (Default)

The time-out time is defined by this bit and REG26.

REG25 (Sleep time)

[Default: 04H]

This register can define the time duration of the sleep mode. Available setting value is 1 to 255. The unit of this setting is defined by bit1 of REG24. (x 10ms or x 100ms). Initial setting is 4 (40ms or 400ms). This time setting is available when the low power stand-by mode is set by PON command.

REG26 (time-out of headerless-packet data input)

[Default: 01H]

This register is available when the transmission mode is headerless packet mode (setting value of REG03 is “FFH”) and the trigger of the data transmission is time-out (the bit 6 of the REG24 is set to “0”). The data packet is transmitted if no data packet is coming during set time by the REG24 and the REG26.

If the bit 0 of the REG24 is set to “0”, the unit of this time set is 1 ms. Similarly, if the bit 0 of the REG24 is set to “1”, the unit of this time set is 10 ms. Available value of the setting is from 01H to FFH, 0 to 255. However, minimum time duration is 3 ms even if the setting is below 3 ms.

The FDP03 returns NO response if “00H” is set to the value.

9. Frequency

9.1 Frequency Range

The available frequency range is from 2,402 MHz to 2477 MHz and it is divided into 76 channels. Below table show a contrast between channel and frequency.

Channel	Frequency	Channel	Frequency	Channel	Frequency	Channel	Frequency
02(02H)	2402MHz	22(16H)	2422MHz	42(2AH)	2442MHz	62(3EH)	2462MHz
03(03H)	2403MHz	23(17H)	2423MHz	43(2BH)	2443MHz	63(3FH)	2463MHz
04(04H)	2404MHz	24(18H)	2424MHz	44(2CH)	2444MHz	64(40H)	2464MHz
05(05H)	2405MHz	25(19H)	2425MHz	45(2DH)	2445MHz	65(41H)	2465MHz
06(06H)	2406MHz	26(1AH)	2426MHz	46(2EH)	2446MHz	66(42H)	2466MHz
07(07H)	2407MHz	27(1BH)	2427MHz	47(2FH)	2447MHz	67(43H)	2467MHz
08(08H)	2408MHz	28(1CH)	2428MHz	48(30H)	2448MHz	68(44H)	2468MHz
09(09H)	2409MHz	29(1DH)	2429MHz	49(31H)	2449MHz	69(45H)	2469MHz
10(0AH)	2410MHz	30(1EH)	2430MHz	50(32H)	2450MHz	70(46H)	2470MHz
11(0BH)	2411MHz	31(1FH)	2431MHz	51(33H)	2451MHz	71(47H)	2471MHz
12(0CH)	2412MHz	32(20H)	2432MHz	52(34H)	2452MHz	72(48H)	2472MHz
13(0DH)	2413MHz	33(21H)	2433MHz	53(35H)	2453MHz	73(49H)	2473MHz
14(0EH)	2414MHz	34(22H)	2434MHz	54(36H)	2454MHz	74(4AH)	2474MHz
15(0FH)	2415MHz	35(23H)	2435MHz	55(37H)	2455MHz	75(4BH)	2475MHz
16(10H)	2416MHz	36(24H)	2436MHz	56(38H)	2456MHz	76(4CH)	2476MHz
17(11H)	2417MHz	37(25H)	2437MHz	57(39H)	2457MHz	77(4DH)	2477MHz
18(12H)	2418MHz	38(26H)	2438MHz	58(3AH)	2458MHz		
19(13H)	2419MHz	39(27H)	2439MHz	59(3BH)	2459MHz		
20(14H)	2420MHz	40(28H)	2440MHz	60(3CH)	2460MHz		
21(15H)	2421MHz	41(29H)	2441MHz	61(3DH)	2461MHz		

(): Hexadecimal indication-

9.2 Frequency Setting and Frequency Group

The FDP03 can use maximum 3 frequency channels as a one group. It can be set by REG06 to REG09. For more details, refer to section 4.2.

Below tables show some examples.

Setting example 1

REG06	REG07	REG08	REG09
03H	02H	2AH	4DH
3-band mode	2402MHz	2442MHz	2477MHz

With the above settings, the FDP03 uses 3 frequency channels, 02H (2,402MHz), 2AH (2,442MHz) and 4DH (2477MHz), as a group. The FDP03 automatically selects the best channel of the wireless condition.

Setting example 2

REG06	REG07	REG08	REG09
01H	4FH	2AH	4DH
1-band mode	2479MHz	2442MHz	2477MHz

With the above settings, the FDP03 uses only 2,479MHz for communication.

Setting example 3

REG06	REG07	REG08	REG09
02H	2AH	2AH	4DH
2-band mode	2442MHz	2442MHz	2477MHz

With the above settings, the FDP03 uses 2 frequency channels that set by REG07 and REG08. However, the FDP03 is uses only 2,442MHz because REG07 and REG08 are set to same channel.



When multiple FDP03 systems are operated in the same area, the frequency channels should be apart at least 2 MHz to avoid the interference from other systems.

9.3 Commands

The host system communicates to the FDP03 by below command.

9.3.1 List of commands

The table below shows the commands.

Command	Function	Remark
ARG	Show the settings of all registers.	
BCL	Clear transmission and reception buffers.	
DAS	Show/set the destination address.	
FNU	Show/set the frequency group.	Groups (1 to 3)
FRQ	Show/set the frequency channel.	Frequencies (02 to 77)
IDR	Show ID code	
IDW	Set ID code	
INI	Initialize all memory registers.	
RST	Reset the FDP03.	
REG	Show/set the memory register	REG00 to REG26
POF	Release low power stand-by mode	
PON	Set low power stand-by mode	
PTE	Show/Set extended stand-by time	
PTN	Show/Set stand-by time	
PTS	Show/Set sleep time	
ROF	RF circuit OFF	
RON	RF circuit ON	
SPD	Show/set data transfer mode	Transfer mode (1 or 2)
TBN	Transmit binary data.	
TID	Show the serial number.	
TS2	Execute a communication test.	
TXT	Transmit text data.	
VER	Show version information.	

9.3.2 Command input format

The input format of a command is as follows:

@xxxx<Cr><Lf> @: Command header
 xxxx: Command code
 <Cr>: Carriage return code
 <Lf>: Line feed code

NOTE

If multiple commands are entered continuously, the commands that are entered before the response from the FDP03 is ignored. Therefore, it should be entered after the FDP03 returns a response for previous command.

9.3.3 Explanation of commands

ARG (Show all registers)

[Format]

ARG

[Response]

List of register settings (REG00 to REG26)

N0: Command error

[Function]

- The FDP03 returns all register settings by this command.
- The register settings are shown in hexadecimal code.

[Examples of use]

>@ARG<Cr><Lf>

<REG00: 00H<Cr><Lf>

<REG01: F0H<Cr><Lf>

.

.

.

<REG26: 01H<Cr><Lf>

BCL (Clear transmission and reception buffers)

[Format]

BCL

[Response]

P0: Normal end

N0: Command error

[Function]

- The transmission and reception buffer is cleared by this command.

[Examples of use]

>@BCL<Cr><Lf>

<P0<Cr><Lf>

NOTE

If this command is executed during data transmission in broadcast transmission mode, newly in coming data might be stored and output after the buffer is cleared.

Also, serial data output is stopped when this command is executed during serial data output.

DAS (Show/set the destination address)

[Format]

DAS (setting value)

setting value: 000 to 255

[Response]

xxx: Current address (in case of address referencing)

P0: Normal end (in case of address setting)

N0: Command error

[Function]

- This command shows and/or sets the destination address of headerless packet transmission mode.
- When this command is entered without any setting values, the FDP03 returns current destination address. If setting value (new address) is put after DAS command, the destination address of the FDP03 is changed to new one.
- Setting of a new address by this command is temporary. If the FDP03 is reset by RST command or initialized, the destination address is returned to the address that is defined by REG02.

[Examples of use]

>@DAS<Cr><Lf>: Show current destination address
<003<Cr><Lf>: Current destination address is "003".
>@DAS001<Cr><Lf>: Set the destination address to "001".
<P0<Cr><Lf>: The destination address is changed normally.

FNU (Show/set a frequency group)

[Format]

FNU (frequency-group)

Available "frequency-group": 1 to 3

[Response]

x: Currently set value

P0: Normal end

N0: Command error

[Function]

- This command shows or sets the frequency group.
- When this command is executed without setting value, current value is recalled.
- Available setting value "x" is 1 to 3. "1" indicates 1 channel mode (fixed frequency channel), "2" means 2 channel mode, and "3" represents 3 channel mode.
- Frequency group setting by this command is temporary. Thus, the setting is returned to that of REG06 after executing RST command or resetting FDP03. For permanent setting, the REG06 should be changed.

"x" (Setting Value)	Description
1	1 channel mode. Frequency channel that defined by REG07 is used.
2	2 channel mode. Frequency channels that defined by REG07 and REG08 are used.
3	3 channel mode. Frequency channels that defined by REG07, REG08 and REG09 are used.

[Examples of use]

>@FNU<Cr><Lf>: This command recalls the current set frequency group.

<3<Cr><Lf>: This response indicates the current set value is "3" (3-band mode).

>@FNU1<Cr><Lf>: This command sets the frequency group to the 1-band mode (1).

<P0<Cr><Lf>: This response indicates the normal end of command processing.

FRQ (Show/set frequency channel)

[Format]

FRQ (number) (:frequency channel)

Available "number": 1 to 3

Available "frequency channel": 02 to 77

[Response]

yy: Current frequency channel (02 to 77)

P0: Normal end

N0: Command error

[Function]

- This command indicates or sets a frequency channel.
- When this command is executed without "frequency channel", current frequency channel is recalled.
- Frequency channel setting by this command is temporary. Thus, the setting is returned to that of REG07, REG08 and REG09 after executing RST command or resetting FDP03. For permanent setting, the REG07, REG08 and REG09 should be changed.

Available setting value of "number" is 1 to 3. "1" indicates the frequency channel set of REG07, "2" indicates the frequency channel set of REG08, and "3" indicates the frequency channel set of REG09.

"number"	Description
1	Frequency channel of REG07
2	Frequency channel of REG08
3	Frequency channel of REG09

[Examples of use]

- >@FRQ1<Cr><Lf>: This command recalls the frequency channel of "frequency channel 1".
 <02<Cr><Lf>: This response indicates the current frequency channel is 02 (2,402MHz).
 >@FRQ2:15<Cr><Lf>: This command sets the "frequency channel 2" to channel "15" (2,415MHz).
 <P0<Cr><Lf>: This response indicates the normal end of command processing.

IDR (Show ID code)

[Format]

IDR

[Response]

xxxxH: Current setting value
(It is the value of REG04 and REG05 right after turned ON the main power.)

[Function]

- This command shows the ID code.

[Example of use]

>@IDR<Cr><Lf>: This command shows the ID code.
<0000H<Cr>Lf>: This response indicates the current ID code is “0000H”.

IDW (Set ID code)

[Format]

IDW

Available setting value: “0000H” to “FFFFFFH”

[Response]

P0: Normal end
N0: Command error

[Function]

- This command can change ID code temporarily. For permanent change, REG04 and REG05 should be changed.

[Example of use]

>@IDW1234H<Cr><Lf>: This command set ID code to 1234.
<P0<Cr>Lf>: Normal end.

INI (initializing memory registers)

[Format]

INI

[Response]

P0: Normal end

N0: Command error

[Function]

- This command resets all memory registers of the FDP03 to initial settings.
- All register settings that are customized are vanished.

[Example of use]

>@INI<Cr><Lf>: This command initializes all memory registers.

<P0<Cr><Lf>: This response indicates the normal end of command processing.

NOTE

The host cannot receive any response from the FDP03 if a communication parameters such as baud rate are different from default setting.

NOTE

It will take 520ms at maximum for P0 response of this command.

CAUTION

Memory registers may get damages if the power of FDP03 is turned off before the P0 response comes back.

REG (Show/set memory registers)

[Format]

REG (register-number) (:setting value)

register-number: 00 to 26

setting value: 00H to FFH (000 to 255)

[Response]

xxH: Current value

P0: Normal end

N0: Command error

[Function]

- This command recalls setting value of memory register and/or sets a value of memory register.
- Available setting value of “register number” is 00 to 26.
- When this command is executed without “setting value”, current value of the defined register is recalled.
- “setting value” should be 3 digit decimal value or 2 digit hexadecimal value . If it is hexadecimal value, “H” should be added at the end of the value.

[Examples of use]

>@REG00<Cr><Lf>: This command recalls the value of REG00.

<00H<Cr><Lf>: This response indicates the current value is “00H”.

>@REG00:001<Cr><Lf>: This command sets value of REG00 to 001

<P0<Cr><Lf>: This response indicates the normal end of command processing.

NOTE

After executing this command to set a new value for a register, be sure to execute the RST command. If you turn off the power of the FDP03 before executing the RST command, the new setting of the register will not be reflected to the FDP03.
It will take 520ms at maximum for P0 response of this command.

RST (resetting the FDP03)

[Format]

RST

[Response]

P0: Normal end

N0: Command error

[Function]

- This command has the following two functions:

- (1) If values of the memory registers are changed before this command is executed, new register settings are registered by this command execution. However, values that are changed by “DAS”, “FUN” and “FRQ” command are vanished and the settings of memory registers are effective.
- (2) This command also makes the FDP03 exit from the line quality test of the “TS2” command. When this command is executed for exit from the line quality test, the memory register settings that are made before execution of the TS2 command are not saved.

[Example of use]

>@RST<Cr><Lf>: This command resets the FDP03.

<P0<Cr><Lf>: This response indicates the normal end of command processing.

NOTE

The host cannot receive any response from the FDP03 if communication parameters such as baud rate are different from default setting.

NOTE

It will take 520ms at maximum for P0 response of this command.

CAUTION

Memory registers may get damages if the power of FDP03 is turned off before the P0 response comes back.

POF (Release low power stand-by mode)

[Format]
POF

[Response]
P0: Normal end
N0: Command error

[Function]
- The operation mode is returned from “Low power stand-by mode” to “Normal operation mode” by this command.

[Example of use]
>@POF<Cr><Lf>: Release low power stand-by mode.
<P0<Cr><Lf>: Normal end.

NOTE

N0 response is returned if this command is executed during normal operation mode.

PON (Set low power stand-by mode)

[Format]
PON

[Response]
P0: Normal end
N0: Command error

[Function]
- The operation mode is set to “Low power stand-by mode..”

[Example of use]
>@PON<Cr><Lf>: Set low power stand-by mode.
<P0<Cr><Lf>: Normal end.

NOTE

N0 response is returned if this command is executed during low power stand-by mode.

PTE (Show/Set extended stand-by time)

[Format]

PTE(:setting value)

Available setting value: 000 to 015

[Response]

xxx: Current setting value (as referring the value)

P0: Normal end (as setting the value)

N0: Command error

[Function]

- This command can refer and/or set the time duration of the extended stand-by time. The extended stand-by time duration is the setting value of this command times 20ms. For example, if the setting value is 010, the extended stand-by time duration is 200ms (010 x 20ms). If the setting value is 000, the extended stand-by time is not available.

[Example of use]

>@PTE<Cr><Lf>: Show current setting value
 <003<Cr><Lf>: The setting value is 003. It means that the extended stand-by time duration is 60ms (003 x 20ms).
 >@PTE015<Cr><Lf>: Set the extended stand-by time duration to 300ms (015 x 20ms).
 <P0<Cr><Lf>: Normal end.

NOTE

If the data packet is sent by broadcasting mode and/or the address check function (REG18) setting is "Disabling group address check at reception", the FDP03 does not turn to the "Extended Stand-by mode" even if the extended time duration is set.

PTN (Show/Set stand-by time)

[Format]

PTN(:setting value)

Available setting value: 001 to 255

[Response]

xxx: Current setting value (as referring the value)

P0: Normal end (as setting the value)

N0: Command error

[Function]

- This command can refer and/or set the time duration of the stand-by time. During the stand-by time, the RF circuit is turned on. The stand-by time duration is the setting value of this command times 10ms. For instance, if the setting value is 010, the extended stand-by time duration is 100ms (010 x 10ms).

[Example of use]

>@PTN<Cr><Lf>: Show current setting value
 <003<Cr><Lf>: The setting value is 005. It means that the stand-by time duration is 50ms (005 x 10ms).
 >@PTN007<Cr><Lf>: Set the extended stand-by time duration to 70ms (007 x 10ms).
 <P0<Cr><Lf>: Normal end.

PTS (Show/Set sleep time)

[Format]

PTS(:setting value)

Available setting value: 001 to 255

[Response]

xxx: Current setting value (as referring the value)

P0: Normal end (as setting the value)

N0: Command error

[Function]

- This command can refer and/or set the time duration of the sleep time. The sleep time duration is the setting value of this command times 10ms if the setting of bit 1 of RGE24 is "0". Also, it is the setting value of this command times 100ms if the setting of bit 1 of RGE24 is "1". For example, if the setting value is 030 and the setting of bit 1 of REG24 is "0", the sleep time duration is 30ms (030 x 10ms). If the setting value is 050 and the setting of bit 1 of REG24 is "1", the sleep time duration is 500ms (050 x 100ms).

[Example of use]

>@PTS<Cr><Lf>: Show current setting value
 <025<Cr><Lf>: The setting value is 025. It means that sleep time is 250ms (as bit 1 of REG24 is "0") or 2500ms (as bit 1 of REG24 is "1").
 >@PTS010<Cr><Lf>: Set the sleep time duration to 100ms (as bit 1 of REG24 is "0") or 1000ms (as bit 1 of REG24 is "1").
 <P0<Cr><Lf>: Normal end.

ROF (RF circuit OFF)

[Format]

ROF

[Response]

P0: Normal end

N0: Command error

[Function]

- This command turns off the RF circuit. If the RF circuit has been already turned off, N0 response is returned after executing this command.

[Example of use]

>@ROF<Cr><Lf>: Turn off the RF circuit.
 <P0<Cr><Lf>: Normal end.

NOTE

During the RF circuit is turned off, @TXT and @TBN command are not available.

RON (RF circuit ON)

[Format]

RON

[Response]

P0: Normal end

N0: Command error

[Function]

- This command turns on the RF circuit. If the RF circuit has been already turned on, N0 response is returned after executing this command.

[Example of use]

>@RON<Cr><Lf>: Turn on the RF circuit.

<P0<Cr><Lf>: Normal end.

SPD (Show/set data transfer mode)

[Format]

SPD(: Data transfer mode)

Data transfer mode: 1 or 2

[Response]

x: Current setting value

P0: Normal end

N0: Command error

[Function]

- This command show and/set data transfer mode.
- The data transfer mode is “Interchange” mode if the setting value is “1”.
- The data transfer mode is “Communication Distance Extend” mode if the setting value is “2”.
- Setting of the data transfer mode by this command is temporary. If the FDP03 is reset by RST command or initialized, the mode is returned to the setting of the bit 5 of the REG10.

x (Setting Value)	Data Transfer Mode
1	Interchange Mode
2	Communication Distance Extend Mode

[Example of use]

>@SPD<Cr><Lf>: Show the data transfer mode.

<1<Cr><Lf> : The mode is “Interchange” mode.

>@SPD2<Cr><Lf>: Set the data transfer mode to “Communication Distance Extend” mode.

<P0<Cr><Lf>: Normal end.

NOTE

The data transfer mode should be same setting among communication partners. If the mode is different each other, it is impossible to communicate with.

TBN (transmit binary data)

[Format]

TBN (destination-address) (length-of-message-bytes) (message)

- destination-address: 000 to 239
 240 to 254 (for group communication)
 255 (for broadcast transmission)
- length-of-message-bytes: 000 to 130
- message: Arbitrary binary data (130 bytes or less)

[Response]

- P0: Normal end
- P1: Command is accepted and data are being transmitted
- N0: Command error
- N1: Data transmission is failed. (The radio modem at the destination address does not respond or transmission cannot be started because of carrier sensing.)
- N3: Data transmission is failed because the receiving data buffer of the destination modem is full.

[Function]

- This command transmits binary data.
- The length of message can be defined from 0 to 130 bytes arbitrary.
- To broadcast data to multiple radio modems, "destination address" should be defined to "255". At this setting, the sender FDP03 transmits data packet "re-transmission frequency" that is defined by REG11 + 1 times and then returns P1 and/or P0 response to the host according to the REG13 setting.

[Examples of use]

- >@TBN001005HELLO<Cr><Lf>: The FDP03 sends the message "HELLO" to the destination modem that wireless address is "001" by this command.
- <P1<Cr><Lf>: This response indicates that the command is accepted and the data is being transmitted.
- <P0<Cr><Lf>: This response indicates the normal end of command processing.

- >@TBN002005HELLO<Cr><Lf>: The FDP03 sends the message "HELLO" to the destination modem that wireless address is "002" by this command.
- <P1<Cr><Lf>: This response indicates that the command is accepted and the data is being transmitted.
- <N1<Cr><Lf>: This response indicates that transmission is failed because the destination modem that wireless address is "002" did not respond or the data transmission was not started by carrier sensing.

NOTE

The length of message should be not more than 130 bytes. It becomes command error if the length of message exceeds 130 bytes. The delimiter of this command should be "<Cr><Lf>". It becomes command error if different delimiter is added.

NOTE

At broadcast transmission mode, the sender FDP03 cannot recognize whether receiver FDP03s receive the transmitted data or not.

CAUTION

Do NOT execute next command before the sender FDP03 receives P0 response. If the setting is "Disabling response" and no P0 response is sent to the sender FDP03, please wait expected P0 response time before executing next command. If next command is executed before P0 response, command error is occurred and the system might have unexpected movement.

TID (show the serial number)

[Format]
TID

[Response]
xxxxxxx: 9-digit serial number
N0: Command error

[Function]
The FDP03 replies its 9 digits serial number when this command is executed.
If it is failed to read the serial number, the FDP03 returns “?”.

[Example of use]
>@TID<Cr><Lf>: This command requests to show the serial number of the FDP03.
< xxxxxxxx <Cr><Lf>: This response indicates the serial number of the FDP03.

TS2 (executing a communication line quality test)

[Format]
TS2

[Response]
P0: Command accepted
Connect: Line connected and line quality test is started
ooooo...ooxo 003: Test result
Disconnect: Line disconnected
N0: Command error

[Function]

- The communication line quality test is executed by this command. At the test, one data packet has 32 bytes and one hundred packets are exchanged as a test unit between the “master” FDP03 and the “slave” FDP03. The test results are output to the serial port.
- The test result is shown by “o” and “x” for each packet. “o” indicates that it is no communication error and “x” indicates that communication error is occurred.
- When this command is executed at the “master” FDP03, the “master” tries to connect the “slave” FDP03 that wireless address is defined by REG02 of the “master”. At that time, operation mode of the “slave” is automatically changed to TS2 communication line quality test mode.
- Both the “master” and the “slave” output the test result.
- Total error occurrence of the test is indicated in 3 digits number after 100 of “o” ”x” judgments.
- If consecutive **1,000** packets become communication error, the line is disconnected. After the disconnection, the “master” continues to request wireless connection but the “slave” abort from TS2 test mode.
- During this TS2 test mode, all the commands except for “FUN”, “FRQ” and “RST” command are do not work. For abort from TS2 test mode, it is needed to execute “RST” command or turned off the main power of the FDP03. When the “master” aborts from TS2 test mode, the “slave” automatically stops the test mode and returns to normal operation mode.

[Example of use]
>@TS2<Cr><Lf>: The FDP03 runs communication test by this command.
<P0<Cr><Lf>: This response indicates that the command is accepted.
<Connect<Cr><Lf>: This response indicates that the line is connected.
<xooooo...ooxo 003<Cr><Lf>: This response indicates the test result and 3 packets became communication errors during 100 packet correspondences.
<oooxoooo...oxoo 002<Cr><Lf>: This response indicates the test result and 2packets became communication errors during 100 packet correspondences.
<ooooooxxo...ooxo 004<Cr><Lf>: This response indicates the test result and 4 packets became communication errors during 100 packet correspondences.
<ooxxxoooo...oxoo 006<Cr><Lf>: This response indicates the test result and 6 packets became communication errors during 100 packet correspondences.

TXT (transmit text data)

[Format]

TXT (destination-address) (message)

- destination-address: 000 to 239
240 to 254 (for group communication)
255 (for broadcast transmission)
- message: Arbitrary binary data (130 bytes or less)

[Response]

- P0: Normal end
- P1: Command is accepted and data are being transmitted
- N0: Command error
- N1: Data transmission is failed. (The radio modem at the destination address does not respond or transmission cannot be started because of carrier sensing.)

[Function]

- This command orders the FDP03 to transmit text data.
- The length of message-can be defined from 0 to 130 bytes and a delimiter indicates the end of message data.
- To broadcast data to multiple radio modems, "destination address" should be defined to "255". At this setting, the sender FDP03 transmits data packet "re-transmission frequency" that is defined by REG11 + 1 times and then returns P1 and/or P0 response to the host according to the REG13 setting.

[Examples of use]

- >@TXT001HELLO<Cr><Lf>: The FDP03 sends the message "HELLO" to the destination modem that wireless address is "001" by this command.
- <P1<Cr><Lf>: This response indicates that the command is accepted and the data is being transmitted.
- <P0<Cr><Lf>: This response indicates the normal end of command processing.
- >@TXT002HELLO<Cr><Lf>: The FDP03 sends the message "HELLO" to the destination modem that wireless address is "002" by this command.
- <P1<Cr><Lf>: This response indicates that the command is accepted and the data is being transmitted.
- <N1<Cr><Lf>: This response indicates that transmission is failed because the destination modem that wireless address is "002" did not respond or the data transmission was not started by carrier sensing.

NOTE

The length of message should be not more than 130 bytes. It becomes command error if the length of message exceeds 130 bytes.

NOTE

If the message includes "<Cr><Lf>," the FDP03 is recognizes that it is the end of the message and it ignores following message. Thus, "TBN" command should be used instead of "TXT" command if the message contains "<Cr><Lf>".

NOTE

At broadcast transmission mode, the sender FDP03 cannot recognize whether receiver FDP03s receive the transmitted data or not.

CAUTION

Do NOT execute next command before the sender FDP03 receives P0 response. If the setting is "Disabling response" and no P0 response is sent to the sender FDP03, please wait expected P0 response time before

executing next command. If next command is executed before P0 response, command error is occurred and the system might have unexpected movement.

VER (reading version information)

[Format]

VER

[Response]

Version information

N0: Command error

[Function]

The FDP03 shows the version of the system.

[Example of use]

>@VER<Cr><Lf>: This command orders to show the version information from the FDP03.

<Version 01.00<Cr><Lf>: This response indicates that the system version of the FDP03 is 1.00.

10. Interface

10.1. Pin Layout

Pin No.	Pin name	Input/output	Remark
1	Vcc	—	Power supply (3.3 to 5.5 VDC)
2	RXD	OUT	Data output
3	TXD	IN	Data input
4	CTS	OUT	Hardware flow control
5	RTS	IN	Hardware flow control
6	TEST	—	(Leave this pin unconnected.)
7	/INI	IN	Parameter initialization
8	/SHUT	IN	Power-off
9	TEST	—	(Leave this pin unconnected.)
10	GND	—	Ground

Explanation of the pins

- Vcc: Power supply pin. Connect a power source and the voltage range is from 2.5 to 5.5 VDC.
- RXD: Data output pin that is the DCE compliant
- TXD: Data input pin that is the DCE compliant
- CTS: Hardware flow control output pin that is the DCE compliant (Hardware flow control is enabled when the signal is high level.)
- RTS: Hardware flow control input pin that is the DCE compliant (Hardware flow control is enabled when the signal is high level.)
- /INI: Parameter initialization pin. Leave this pin unconnected when it is not used. To initialize the registers, set the /INI pin to low level at power-on or combine the operation of this pin with the operation of the /SHUT pin. After the registers (parameters) are initialized, the FDP01 operates in normal mode.
- /SHUT: Power-off pin. When this pin is set to low level, the main power of the FDP03 is cut and becomes “power-down” mode. When the setting of this pin is high level, the FDP03 is in normal operation mode.
- TEST: Test pin. Do NOT use this pin. This pin is only for maintenance by the manufacturer.
- GND: Ground pin



Parameter setting of the register will be vanished if the /SHUT pin becomes low level and the operation mode becomes “power-down” mode. Therefore, DO NOT connect /SHUT pin during REG command setting.



After releasing from the power-down mode, parameter settings of registers that were changed by commands will be initialized. Thus, the parameter settings should be done by the memory registers when the “power-down” mode is used or set the parameters again after returning from the “power-down” mode.



It will take 90 ms at the maximum to return from the “power-down” mode to normal operation mode.

10.2. Recommended Connector

Hirose Electric Co., Ltd. DF12E(3.0)-10DP-0.5V

10.3. Electrical Characteristics

Symbol	Item	Minimum	Typical	Maximum	Unit	
V_{CC}	Power supply voltage	2.5	-	5.5	V	
V_{IH}	High-level input voltage	1.6	-	2.2	V	
V_{IL}	Low-level input voltage	0	-	0.5	V	
$V_{IH(SHUT)}$	High-level input voltage at /SHUT pin	1.45	-	V_{CC}	V	
$V_{IL(SHUT)}$	Low-level input voltage at /SHUT pin	0	-	0.25	V	
V_{OH}	High-level output voltage	1.9	-	2.2	V	
V_{OL}	Low-level output voltage	0	-	0.2	V	
I_{CC}	Power supply current	Normal Mode	-	-	45	mA
		Low Power Stand-by Mode	-	-	2	mA
		RF Circuit Power Control Mode	-	-	2	mA
		Power Down Mode	-	3	5	uA

10.4. AC Characteristics

10.4.1. Main Power On

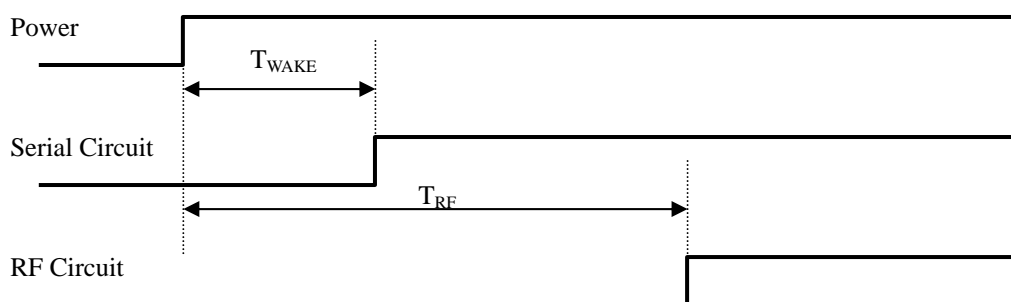

Symbol	Item	Minimum	Typical	Maximum	Unit
T_{WAKE}	Serial circuit wake-up time delay	-	-	20	mS
T_{RF}	RF circuit wake-up time delay	-	-	90	mS

10.4.2 Low Power Stand-by Mode

10.4.2.1 Transition to low power stand-by mode by PON command

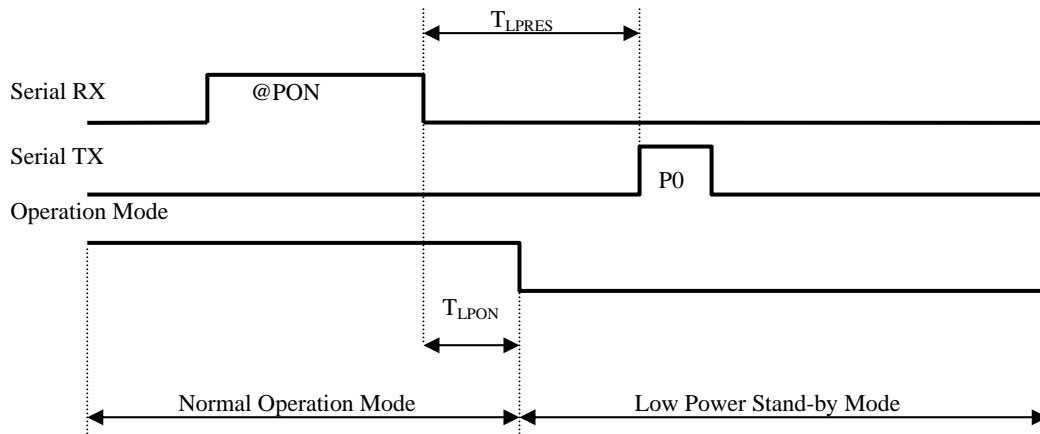

Symbol	Item	Minimum	Typical	Maximum	Unit
T_{LPRES}	Response time delay of serial circuit	-	-	1	mS
T_{LPON}	Transition time to low power stand-by mode	-	-	340	uS

NOTE

A command for sending data packet is available after receiving P0 response.

10.4.2.2 Transition from low power stand-by mode to normal operation mode by POF command

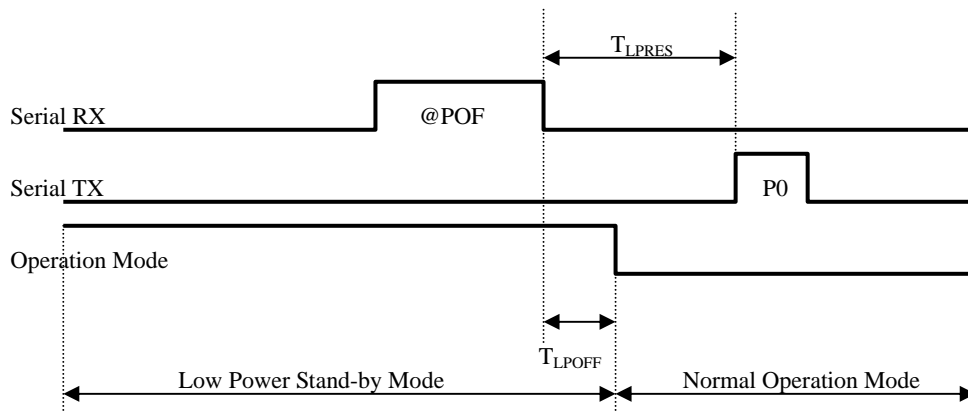

Symbol	Item	Minimum	Typical	Maximum	Unit
T_{LPRES}	Response time delay of serial circuit	-	-	1	mS
T_{LPON}	Transition time to normal operation mode	-	-	340	uS

NOTE

A command for sending data packet is available after receiving P0 response.

10.4.2.3 Enable timing of data packet receiving during low power stand-by mode

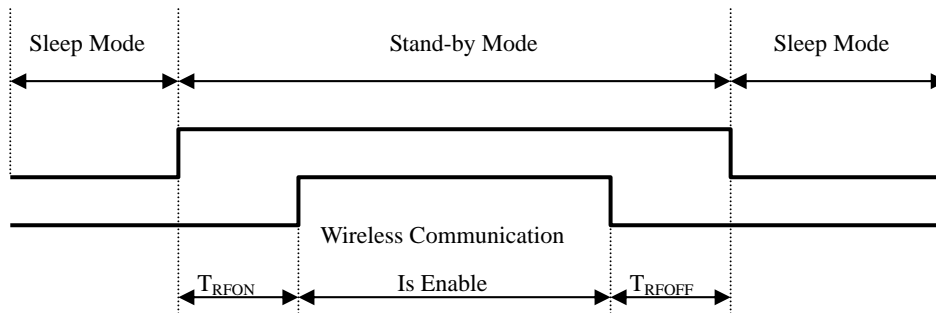

Symbol	Item	Minimum	Typical	Maximum	Unit
T_{RFON}	Time delay for wireless communication	-	-	1	mS
T_{RFOFF}	Time difference of wireless communication stop	-	-	340	uS

10.5.3. RF Circuit Power Control Mode

10.5.3.1. Transition of RF circuit from RF Off to RF On

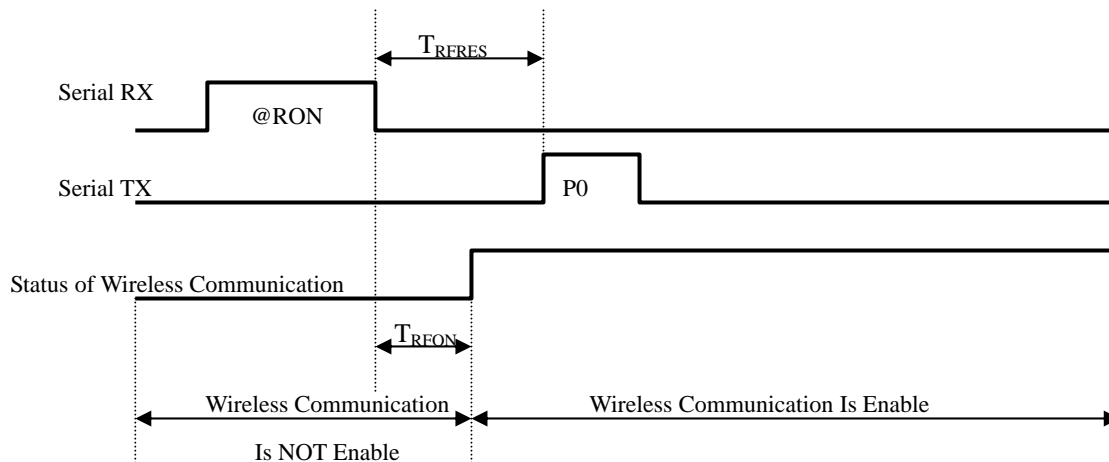

Symbol	Item	Minimum	Typical	Maximum	Unit
T_{RFRES}	Response Time of Serial Circuit for RF Control	-	-	1	mS
T_{RFON}	Transition Time for Operation Mode Change	-	-	340	uS

NOTE

A command for sending data packet is available after receiving P0 response.

10.5.3.2 Transition of RF circuit from RF On to RF Off

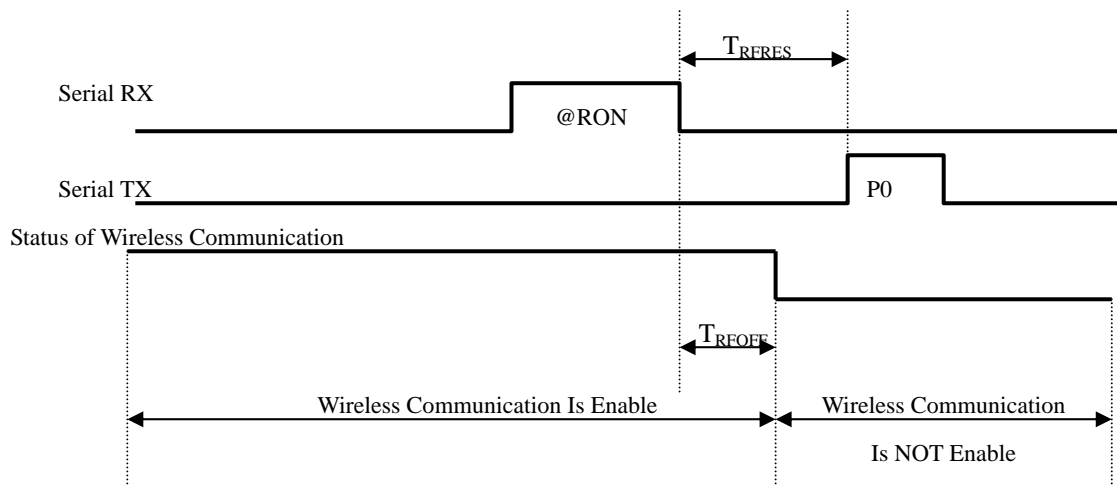

Symbol	Item	Minimum	Typical	Maximum	Unit
T_{RFRES}	Response Time of Serial Circuit for RF Control	-	-	1	mS
T_{RFOFF}	Transition Time for Operation Mode Change	-	-	340	uS

NOTE

A command for sending data packet is available after receiving P0 response.

10.5.4. Power Down Mode

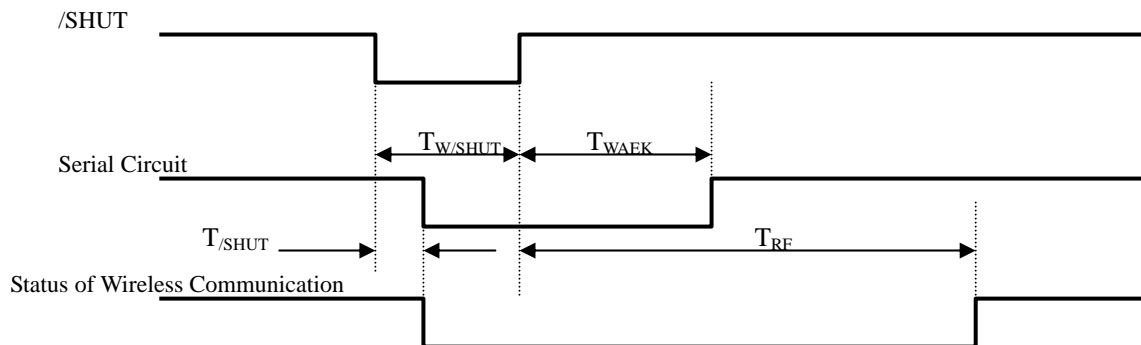

Symbol	Item	Minimum	Typical	Maximum	Unit
$T_{W/SHUT}$	Pulse Width of /SHUT	3	-	-	mS
T_{SHUT}	Shut Down Time	-	-	500	uS
T_{WAEK}	Recovery Time of Serial Circuit	-	-	20	mS
T_{RF}	Enable Time Duration of Wireless Communication	-	-	90	mS

10.5.5. Parameter Initializing by /SHUT and /INI Terminal

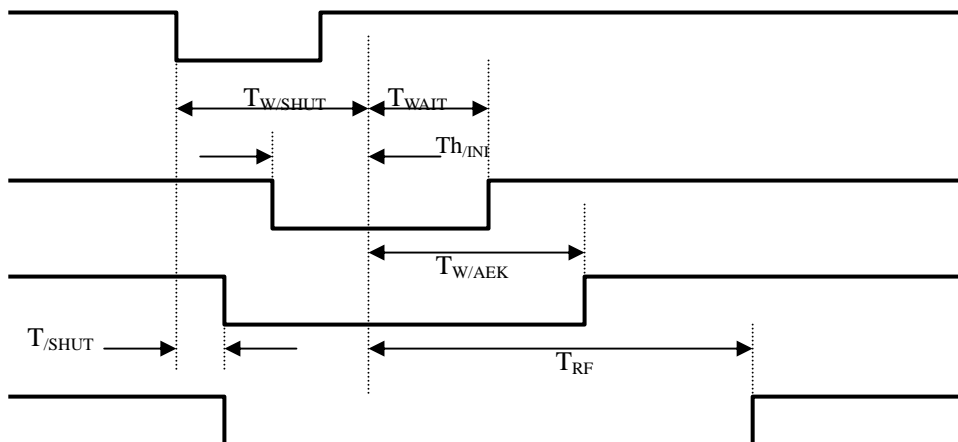

Symbol	Item	Minimum	Typical	Maximum	Unit
$T_{W/SHUT}$	Pulse Width of /SHUT	3	-	-	mS
$T_{h/INI}$	Hold Time of /INI Signal	0	-	-	mS
T_{WAIT}	Enable Time of /INI Signal	15	-	-	mS
T_{SHUT}	Shut Down Time	-	-	500	uS
$T_{W/AEK}$	Recovery Time of Serial Circuit	-	-	40	mS
T_{RF}	Enable Time Duration of Wireless Communication	-	-	100	mS

NOTE

It will take 90 ms at the maximum to return from the “power-down” mode to normal operation mode.

NOTE

When the parameters of FDP03 is initialized by /SHUT terminal and /INI terminal, the serial circuit is ready in 40ms after /SHUT terminal is set to “High” level. However, it will take 100ms to ready to the RF circuit because the RF circuit checks communication acceptance.

11. Product Specifications
 11.1. Outer Dimensions

43 x 25 x 3 mm (excluding connectors)

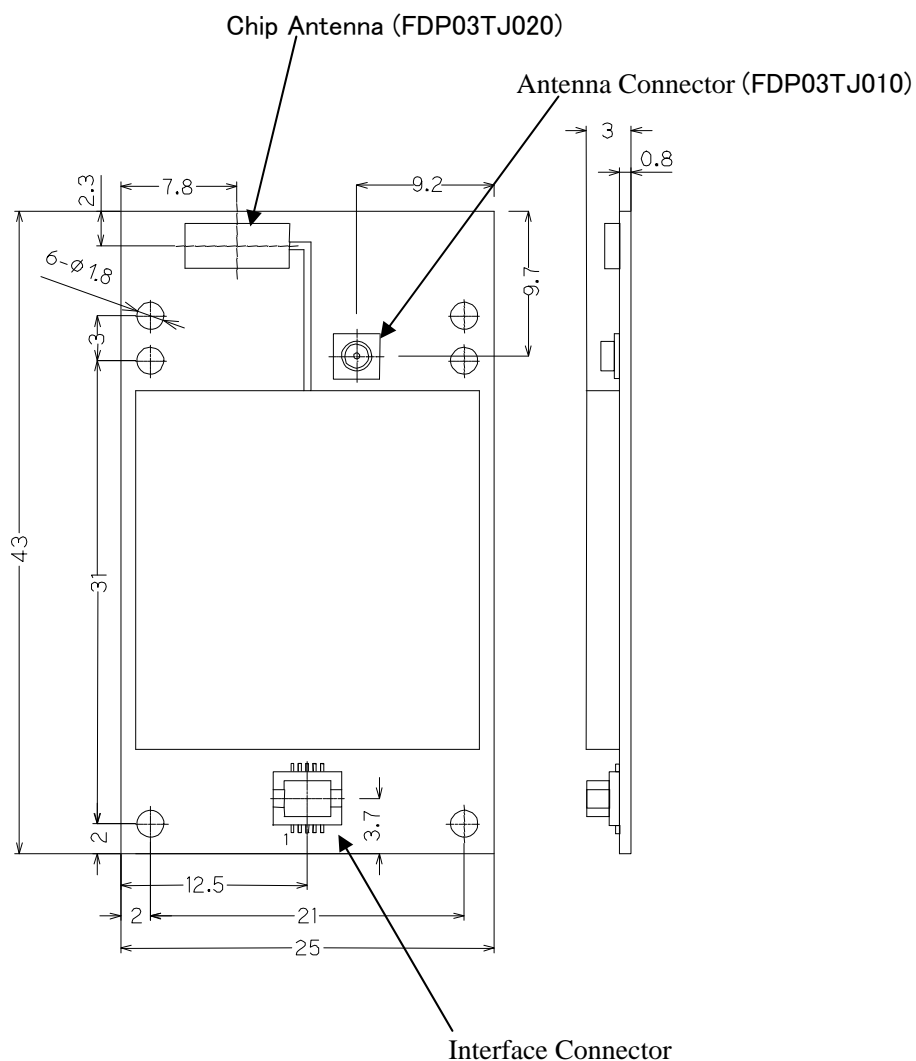

11.2. Weight

Approximately 3.6 g

11.3. Power Supply

Voltage : 2.5 to 5.5 VDC

Current :

Operation Mode	MIN.	TYP.	MAX.	Unit
Normal Operation Mode	-	-	45	mA
Low Power Stand-by Mode	-	-	2	mA
RF Circuit Power Control Mode	-	-	2	mA
Power Down Mode	-	3	5	uA

11.4. Radio Specifications

Technical standard:	ARIB STD-T66 (Japan) FCC Part 15.237 (U.S.) ETSI EN 300 328 V.1.7.1 (EU)
Certification number:	001NYDA1387 (Japan) AZP-FDP03 (U.S.)
Communication method:	FSK
Service area:	100m (“Interchange” mode: open-air line-of-sight distance) 200m (“Communication Distance Extend” mode: open-air line-of-sight distance)
Transmission output power:	10 mW
Number of frequency channels:	76 (2,402 to 2477 MHz)
Line speed:	1 Mbps (“Interchange” mode), 250kbps (“Communication Distance Extend” mode)
Actual Throughput:	22kbps MAX. (if the line speed of the interface is 115.2kbps.)
Connector:	U.FL made by Hirose Electric Co., Ltd.
Antenna:	Connector IPEX 20279-001E-01 (FDP03TJ010) Built-in (FDP03TJ020)

10.5 Interface

Protocol:	2.2 V asynchronous (DCE specifications)
Line speed:	9,600, 19,200, 38,400, or 115,200 bps
Data length:	7 or 8 bits
Stop bit:	1 or 2 bits
Parity:	Odd, even, or no parity
Connector:	DF12C(3.0)-10DS-0.5V (Hirose Electric Co., Ltd.)

10.6 Environment

Operating temperature:	-20°C to 60°C
Storage temperature:	-30°C to 70°C
Operating humidity:	90% RH or less (without condensation)
Storage humidity:	90% RH or less (without condensation)
Vibration tolerance:	Compliant with JIS-C-60068-2-6
Shock resistance:	Compliant with JIS-C-60068-2-27

11. Notes

11.1 Data Communication Delay

It will take certain time to synchronize when the frequency group setting is 2 frequency channel mode or 3 frequency channel mode.

11.1.1 Delay at the transmission side

(1) Delay due to the number of frequency channels in use

When the setting of the FDP03 is 2 frequency channel mode and/or 3 frequency mode, the FDP03 changes the data transmission frequency channel as every data re-transmission. It takes 7.6 ms to re-transmit a data packet for packet generation, carrier sensing and waiting ACK time-out. Thus, the data communication will be delay when the setting of the FDP03 is 2 frequency channel mode and/or 3 frequency mode.

(2) Delay due to carrier sensing

If the FDP03 detects radio wave that is same frequency channel as own use, the FDP03 switches the carrier frequency channel to another. It is called "carrier sensing" and takes 7.6 ms. Thus, the data communication will be delayed if other wireless systems such as WiFi in the same area.

11.1.2 Delay at the reception side

(1) Delay due to extension of reception-wait time

The FDP03 extends reception-wait time according to the frequency it has received. The extended reception-wait time depends on the on the number of frequencies in the frequency group, which is " $10+5 \times (\text{number of frequencies in the frequency group})^2$ " ms. Since the FDP03 keeps the same frequency during the extended reception-wait time, the extension of reception-wait time may cause a delay in communication in an environment with much noise or jamming.

11.2 Reception of Same Packets

The FDP03 can store five packets of received data in the reception data buffer. However, when it receives more than 5 packets, the FDP03 deletes the data packet from the oldest data one after the other. For example, if the local FDP03 receives data packets from six remote FDP03s at the same time, one of the received data packet is eliminated. Therefore, when the FDP03 receives a data packet that is same as the eliminated one, the FDP03 cannot realize the duplication of the data packet and output the data to the host. It will happen when the FDP03 is used in below listed condition.

- (1) More than seven ~~or more~~ FDP03s operate at the same time in the system.
- (2) Data re-transmission is frequent.
- (3) The data packets having the same packet size are transmitted.

Even if the local FDP03 cannot receive the ACK signal of a packet from the remote FDP03, the remote FDP03 may success to received the packet.

11.3 Timing of Command Input

Do NOT execute next command before the sender FDP03 receives P0 response. If the setting is "Disabling response" and no P0 response is sent to the sender FDP03, please wait expected P0 response time before executing next command. If next command is executed before P0 response, command error is occurred and the system might have unexpected movement.

When "Disabling response" is defined, the command should be executed after waiting the specific time that is defined by REG15.

11.4 Headerless Packet Transmission Mode

11.4.1 Input data

In headerless packet transmission mode, up to 150 bytes of message can be stored in the transmission buffer, and transmission starts when the total length of the messages stored in the message buffer exceeds 26 bytes. If many messages are input successively, the message buffer may become full because wireless transmission cannot keep pace with message input, and some messages may be lost. If such an event occurs, enable the hardware flow control. You are recommended to specify "Enabling response" also in headerless packet transmission mode since, with this setting, you can confirm the success or failure in message transmission with each response.

11.4.2 Measures against packet loss

(1) Messages exceeding 26 bytes

If messages not less than 26 bytes in total are input successively, transmission of some messages input earlier may fail. To prepare for such an event, check each response on the sender FDP03 to prevent the loss of messages, and create messages so that the loss of packets can be determined on the receiver FDP03.

(2) Setting of serial communication speed

If different serial communication speeds are set on the sender FDP03 and the receiver FDP03, the loss of data may occur on the FDP03 configured with a slower speed than that of the other FDP03. Therefore, you are recommended to set the same serial communication speed on all FDP03s.

11.5 Occurrence of Data Loss Even under Hardware Flow Control

If the FDP03 is connected to a personal computer and a specific software program created on the personal computer is used, the data output from the personal computer to the FDP03 does not stop immediately even when the input to the FDP03 is disabled by hardware flow control. In such cases, the data output from the personal computer may be lost.

11.6 Frequency Setting in Multi-System Environment

If multiple FDP03 systems are operating, set the radio frequencies that are apart from each other at least by 2 MHz on individual FDP03s. If adjacent communication channels are set on different FDP03s, interference may occur and disable the FDP03s to communicate.

11.7 Timing of Command Input

When entering multiple commands successively, wait, after entering a command, until the P0 response for the entered command is received before entering the next command. If the next command is entered before the P0 response for the preceding command is received, an error occurs or the entered next command is ignored.

11.8 INI and RST Commands

After executing the INI or RST command, always check that the P0 response is returned. Turning off the power of the FDP03 before the P0 response is returned may damage memory registers. If the return of P0 response cannot be checked, for example, in case that the baud rate has been initialized, wait for 520 ms or more after entering the INI or RST command, and then turn off the power.

11.9 Power-Down Mode

Switching the FDP03 to the power-down mode (by setting the /SHUT pin to the low level) while registers of the FDP03 are being accessed may delete the settings in the registers. To avoid this problem, do not control the /SHUT pin while the REG command is being executed.

Releasing the FDP03 from the power-down mode clears the parameter settings in registers that were made with commands before the FDP03 was set into the power-down mode. Change the parameter settings before using the power-down mode, or make the parameter settings again after releasing the FDP03 from the power-down mode.

The FDP03 returns to the normal operation in a maximum of 120 ms after the FDP03 is released from the power-down mode.

How to obtain Help

Please contact Futaba technical support at the address shown below for:

Application information regarding the FDP or other Futaba products.

Technical Assistance or Training

Safety Questions

Additional manuals or other documentation

Repair or service for your Futaba products

Comments regarding the product or this manual

- Do not modify or disassemble the product.

* The specifications and external designs of this product may be changed for improvement without prior notice.

* Futaba Corporation will not be liable for any damages resulting from the use of the product that has been modified without prior consent of Futaba Corporation.

In Japan

Futaba Corporation

1080 Yabutsuka, Chosei-mura, Chosei, Chiba Prefecture 299-4395, Japan

Telephone: +81-475-32-2151, Fax: +81-475-32-6179

In United States

Futaba Corporation of America

711 E. State Parkway Schaumburg, Illinois 60173, U.S.A

TEL: +1-847-884-1444 FAX: +1-847-884-1635

In Europe

Futaba (Europe) GmbH

Halskestrasse 9, D-47877 Willich, Germany

TEL: +49-2154-943-0 FAX: +49-2154-943-200

In Asia

FUTABA DENSHI Corp. (S) Pte.Ltd.

152 Beach Road, The Gateway East, #23-08, Singapore 189721

TEL: +65-6291-9882 FAX: +65-6291-7391

For inquiries or more information, contact:

- Industrial Equipment Sales Unit, Radio Control Equipment Group, Futaba Corporation
1080 Yabutsuka, Chosei-mura, Chosei, Chiba Prefecture 299-4395, Japan
Telephone: 0475-32-6173
Facsimile: 0475-32-6179
- URL of Futaba's Website: <http://www.futaba.co.jp>

INSTRUCTIONS MANUAL FEDERAL COMMUNICATIONS COMMISSION INTERFERENCE STATEMENT

This equipment has been tested and found to comply with the limits for a Class B digital device, pursuant to Part 15 of the FCC Rules. These limits are designed to provide reasonable protection against harmful interference in a residential installation. This equipment generates, uses, and can radiate radio frequency energy and, if not installed and used according to the instructions, may cause harmful interference to radio communications. However, there is no guarantee that interference will not occur in a particular installation. If this equipment does cause harmful interference to radio or television reception, which it found by turning the equipment off and on, the user is encouraged to try to correct the interference by one or more of the following measures:

- Reorient or relocate the receiving antenna.
- Increase the separation between the equipment and receiver.
- Connect the equipment into an outlet other than the receiver's
- Consult the dealer or an experienced radio/TV technician for assistance.

CAUTION:

To assure continued FCC compliance:

- (1) Any changes or modifications not expressly approved by the grantee of this device could void the user's authority to operate the equipment.

FCC Label Compliance Statement:

This device complies with Part 15 of the FCC Rules. Operation is subject to the following two conditions: (1) this device may not cause harmful interference, and (2) this device must accept any interference received, including interference that may cause undesired operation.

Exposure to Radio Frequency Radiation

To comply with FCC RF exposure compliance requirements, a separation distance of at least 20cm must be maintained between the antenna of this device and all persons. This device must not be co-located or operating in conjunction with any other antenna or transmitter.