

Instruction Manual

F D K 0 1 T U

This instruction manual contains important notices and how to use this product safely. Please be sure to read this instruction manual before you use this product. Please understand the following symbols that are used in this manual before reading this instruction manual.

The symbols are defined as follows:



Indicates a hazard that can cause severe personal injury, death, or substantial property damage if the warning is ignored.



Indicates a hazard that will or can cause minor personal injury, or property damage if the caution is ignored.

F C C N o t i c e s

This equipment has been tested and found to comply with the limit for a Class B digital device, pursuant to part 15 of the FCC rules. These limits are designed to provide reasonable protection against harmful interference in a residential installation. This equipment generates, uses and can radiate radio frequency energy and, if not installed and used in accordance with the instructions, may cause harmful interference to radio communications. However, there is no guarantee that interference will not occur in a particular installation. If this equipment does cause harmful interference to radio or television reception, which can be determined by turning the equipment off and on, the user is encouraged to try to correct the interference by one or more of the following measures:

- Reorient or relocate the receiving antenna.
- Increase the separation between the equipment and receiver.
- Connect the equipment into an outlet on a circuit different from that to which the receiver is connected.
- Consult the dealer or an experienced radio/TV technician for help.

The user that changes or modifications not expressly approved by the party responsible for compliance could void the user's authority to operate the equipment.

⚠ WARNING

The following six are extremely important warnings.

1. Be sure to use this product within its specification; otherwise it may cause failures and malfunctions. Especially, pay great attention to temperature range and power source voltage.
2. Do not install this product to the sites where the product is disposed under the direct sunlight and/or under the high temperature. Prior to use this product, please make sure the temperature around the site where you are planning to use this product, because this product is guaranteed at the limited ranges in operating temperature and storage temperature. Operating the product beyond the guaranteed temperature range may cause failure of this product.
3. Do not install this product in a high humidity area. A drop of water on the circuit inside of this product may cause failure of this product.
4. Avoid this product from being watered. If water enters inside this product, it may cause failure of this product.
5. The specification of the external interface of this product is different from ordinary one. Please make sure the wire identifications before connecting external equipment.
6. Be sure to confirm that the power switches are off before connecting or disconnecting connectors. Connecting and disconnecting connectors while any power is on may cause failures and malfunctions.

⚠ CAUTION

The following three are very important cautions in handling this product.

1. This product is designed specially for industrial applications. If you are planning to use this product in the area where the use of electromagnetic wave is restricted because medical equipment and airplanes are used near its area, please confirm that this product does not interfere with those before you use this product. Please do not use this product unless you can confirm that this product does not interfere with those medical equipment and airplanes near the site.
2. Please pay attentions to the electromagnetic conditions around this product. This product uses electromagnetic wave as a communication method. Consequently, if there is a strong source of electromagnetic wave near this product, this product may not able to fully achieve its performance. Please check the electromagnetic conditions around the site where you are planning to use this product prior to use this product.
3. This instruction manual is protected by the law of copyright protects. Futaba Co. is not responsible to any problem and incident that are caused from reprinting this instruction manual by somebody other than Futaba.

TABLE OF CONTENTS

1. INTRODUCTION	
1-1. Special Features	p.1
1-2. Names and functions of parts of the fixed station	p.1
1-3. Names and functions of parts of the matching/distributing unit	p.3
1-4. Names and functions of parts of the terminator unit	p.3
2. POWER	
2-1. Before turning on the power	p.4
2-2. Voltage of the power source	p.4
2-3. Connector for the power source	p.4
2-4. Power switch	p.4
3. ATTACHMENT OF FEEDER CABLES	
3-1. Connecting the fixed station and the matching/distributing unit	p.5
3-2. Connecting feeder cables and the matching/distributing unit	p.5
3-3. Connecting feeder cables to the terminator unit	p.7
3-4. Attaching Ferrite core to the feeder cable	p.9
4. CONNECTING COMMUNICATION CABLE	
4-1. Connector for RS-232C/RS-422/RS-485	p.10
5. SETTING SWITCHES	p.11
6. SYSTEM OPERATION	
6-1. Outline of communication	p.14
6-2. Preparation of communication on the air	p.14
6-3. Data communication with serial port of the wireless modem	p.14
7. COMMUNICATION WITH MOBILE STATIONS	p.15
8. COMMUNICATION COMMAND	p.16
9. CONTROL COMMAND	p.17
10. ADDRESS	p.19
11. INDICATORS	p.20
12. EXTERNAL RESET	p.21
13. PRODUCT SPECIFICATION	p.22
14. FREQUENCY CHANNEL	p.24

1. INTRODUCTION

1-1. Special Features

- 1) FDK01TU (fixed station) outputs its modulated signals to the 200-ohm feeder cables, demodulates the modulated signals of a FDK02TU (mobile station) that come through the feeder cable, and sends them to FDK01TU's external controllers.
Please note that a matching/distributing unit is necessary to attach one or two 200-ohm feeder cables to this modem.
- 2) Communication speed is 100kbps across the feeder wires.
- 3) FDK has a function to carry out error correction by the combination of ARQ (Automatic Retransmission Request) and FEC of BCH (15,7).
- 4) In this system, multiple mobile stations can be allocated to the single feeder cable. And each mobile station can have individual address that can be set externally. As a result, a single fixed station and multiple mobile stations can establish a communication network.
- 5) The interface between the external controller and the fixed station or the one between the external controller and the mobile stations is designed to meet RS-422, RS-485 and RS232C.

1-2. Names and functions of parts of the fixed station

- Indicators of signal reception level
- Indicator of signal transmission
- Switches to set address
- Switches to set frequency channels
- Switches to set communication parameters
- Switches to set external interface, transfer speed, and etc.
- Switches to set parameters for RS-422/RS-485
- Indicator of the power status

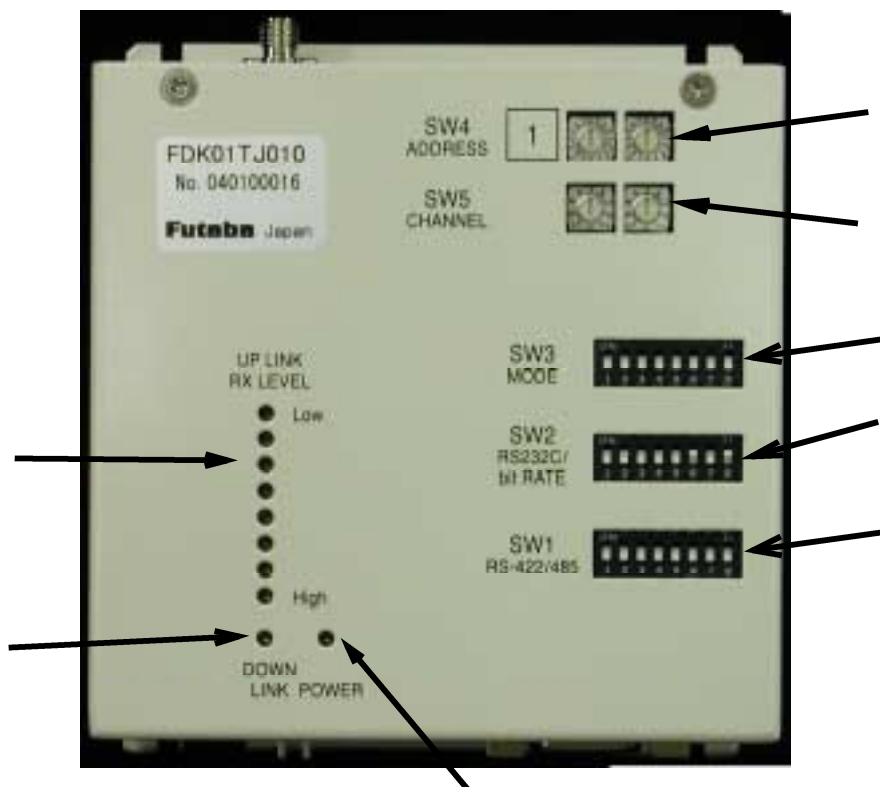

Power switch

Connector to a 24V power source

Connector for external reset control

Interface connector for RS-232C/RS-422/RS-485 (Special pin assignment is employed here.)

Connector for Matching/distributing unit



1-3. Names and functions of parts of the matching/distributing unit

Connector to the fixed station (BNC)
Opening for connecting a feeder cable
These parts are for screws to fix this unit.

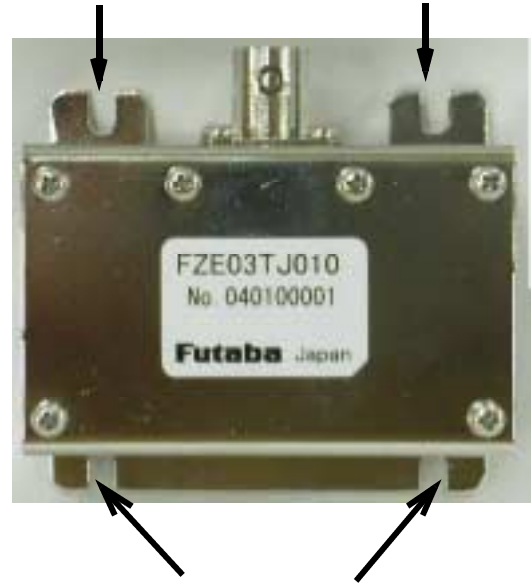

1-4. Names and functions of parts of the terminator unit

Opening for connecting a feeder cable
These parts are for screws to fix this unit.



2. POWER

2-1. Before turning on the power

Be sure to read this instruction manual prior to turning on the power of the modems.

Improper operations of the FDK modem may not only cause failures of communication but also cause malfunctions and/or damages of this modem and the external equipment connected to this modem.

In order to establish proper communication between this modem and mobile stations, communication parameters should be set by switches, which should be set before turning on the power switch.

In addition, since Futaba has specially defined the pin-assignment of interface connector for RS-232C/RS-422/RS-485; please carefully confirm the wire identifications of the interface cable and pin layout.

2-2. Voltage of the power source

The input voltage to this modem should be within the range of 20Vdc and 29Vdc. Otherwise, this modem and the external equipment connected to this modem may cause damages or malfunctions.

2-3. Connector for the power source

The type of the connector used for this modem is S2P-VH made by J.S.T. Mfg Co., Ltd. Supply the voltage anywhere between 20Vdc and 29Vdc to the "+" marked terminal and connect the ground wire to the "-" marked terminal.

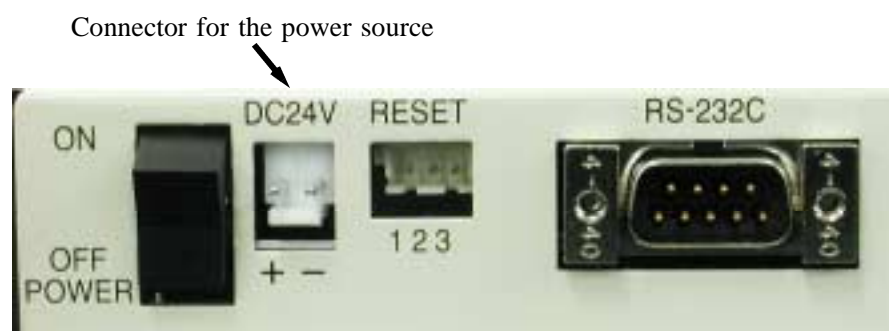

Picture 2-3

2-4. Power switch

The label "POWER" is printed beside the power switch of this modem. (See picture 2-4)

Pushing this switch toward "ON" will turn on the power switch and the LED indicator of the power on top of the unit turns on green. On the other hand pushing the switch toward "OFF" will turn off the power. The picture 2-4 shows "OFF" state.



Picture 2-4

3. ATTACHMENT OF FEEDER CABLES

3-1. Connecting the fixed station and the matching/distributing unit

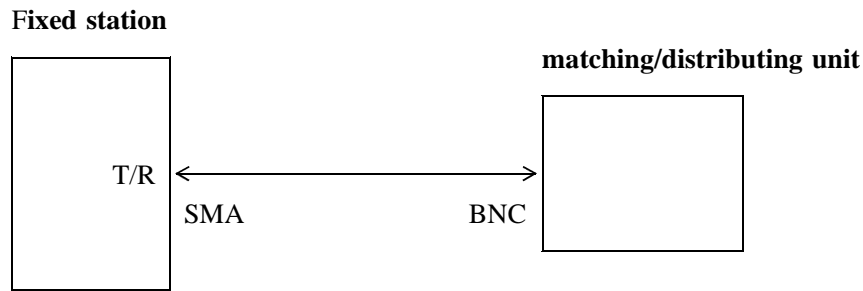

3-2. Connecting feeder cables and the matching/distributing unit

Please follow the next procedures and also refer to the related figure.

- a) Remove the six screws on top of the terminator unit to open the unit cover.
- b) Turn the two screws that are located in center of one of the terminal pads so that metal wire of a feeder cable can fit in.
- c) Turn the screws of the cable holder made of black resin.
- d) Insert a feeder cable into a hole of the chassis and then insert the two bunches of conductive wires of the feeder cable separately into the two holes in the terminal pad.
Please make sure that twisted wires do not loosen and touch the neighboring wires. If a single wire of a bundle touches the other bundle, communication cannot be established.
- e) Tighten the two screws on top of the terminal pad.
- f) Tighten the screws of the cable holder made of black resin.
- g) Connect another feeder cable to the other side of the unit following the procedure of above b) through f). If another feeder cable is not required, attach 200-ohm resistor to the terminal pad.
- h) After confirming that screws are firmly tightened, cover the top chassis and tighten the six screws.

2.ファイダー線と装置の接続

2-3.整合分配器への取り付け方法

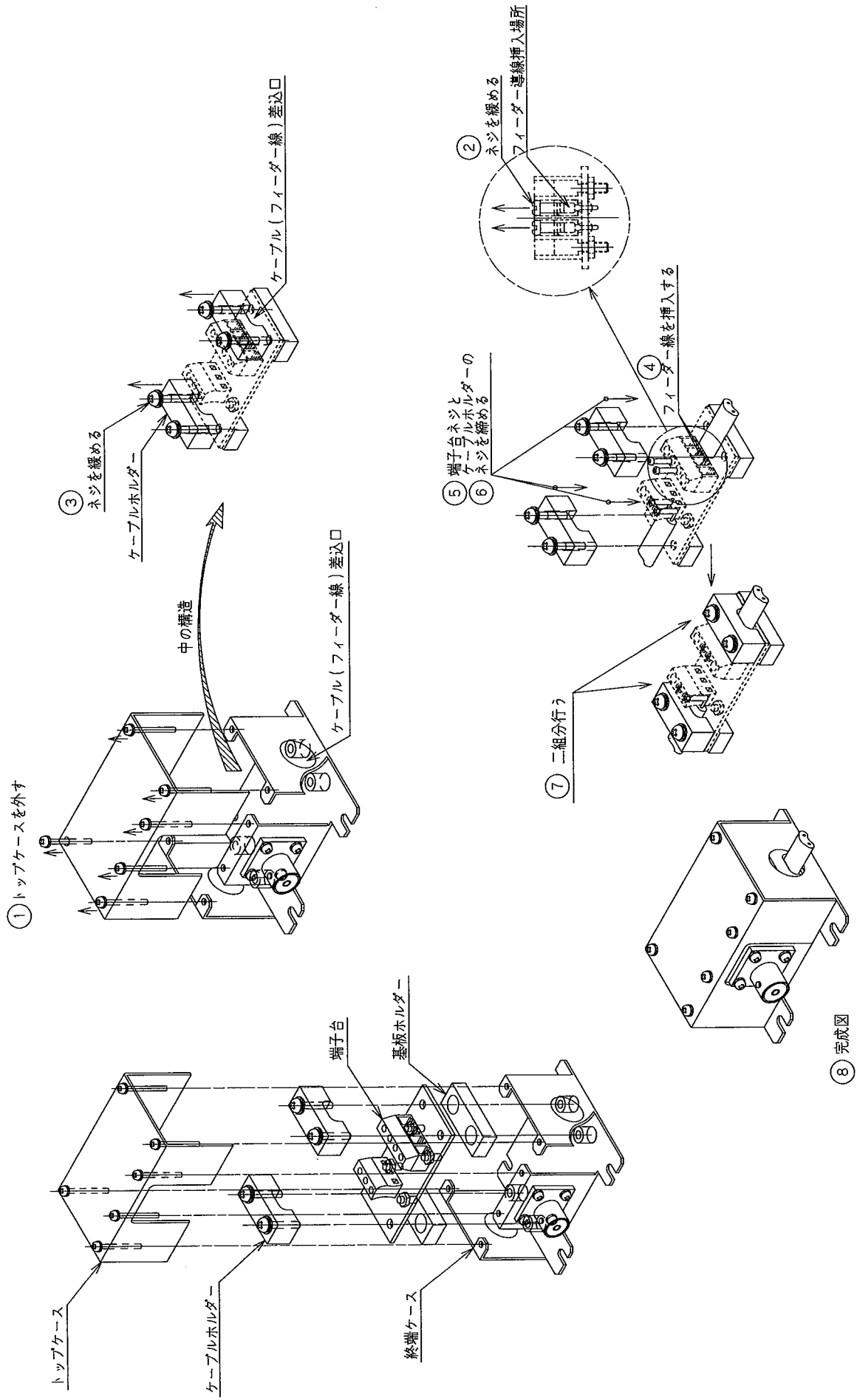

3-3. Connecting feeder cables to the terminator unit

Please follow the next procedures and also refer to the related figure.

- a) Remove the six screws on top of the terminator unit to open the unit cover.
- b) Turn the two screws that are located in center of one of the terminal pads so that metal wire of a feeder cable can fit in.
- c) Turn the screws of the cable holder made of black resin.
- d) Insert a feeder cable into a hole of the chassis and then insert the two bunches of conductive wires of the feeder cable separately into the two holes in the terminal pad.
Please make sure that twisted wires do not loosen and touch the neighboring wires. If a single wire of a bundle touches the other bundle, communication cannot be established.
- e) Tighten the two screws on top of the terminal pad.
- f) Tighten the screws of the cable holder made of black resin.
- g) After confirming that screws are firmly tightened, cover the top chassis and tighten the six screws.

2.ファイダー線と装置の接続
2-2.終端への取り付け方法

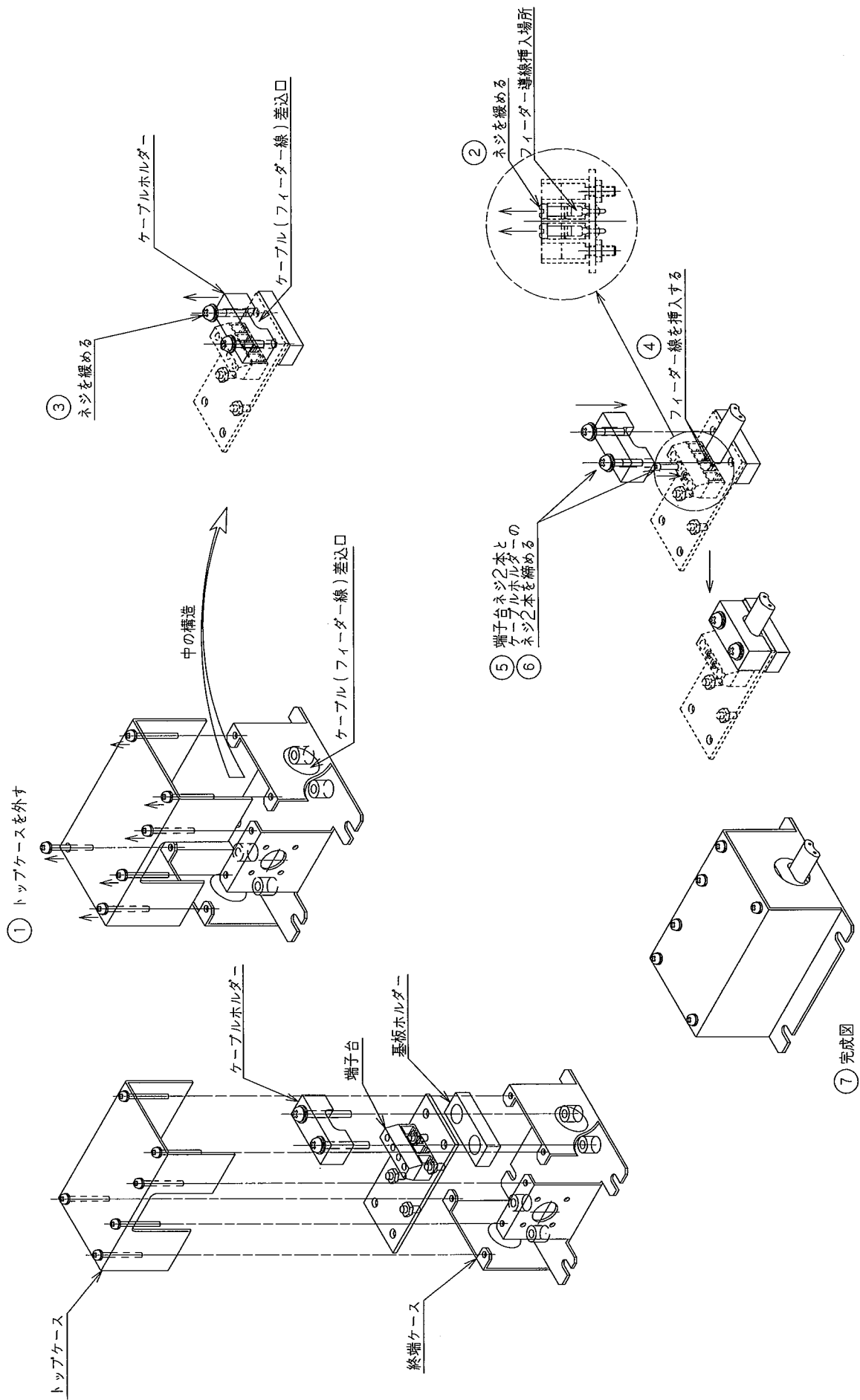

3-4. Attaching Ferrite core to the feeder cable

Be sure to attach ferrite cores to the feeder cable in order to reduce radiation noise in differential mode. Attach one ferrite core to the end of the feeder cable that is connected to the matching/distributing unit and attach another ferrite core to the other end of the feeder cable that is connected to the terminator unit. Impedance of each ferrite core for both sides should be 800-ohm, which instead can be comprised of several small ferrite cores like four pieces of 200-ohm.

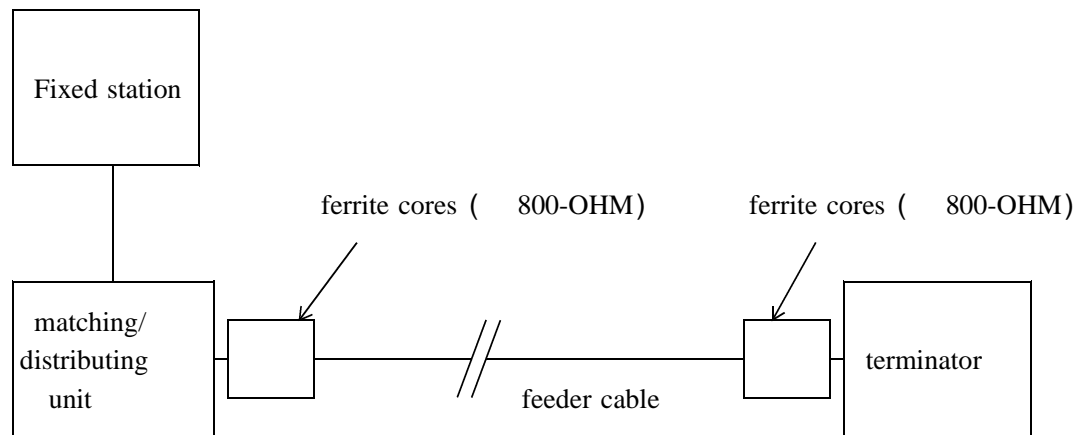

ferrite core

TAKEUCHI KOGYO CO.

SFT-72S Impedance 210-ohm(100MHz) 4 pieces(each side)

4. CONNECTING COMMUNICATION CABLE

4-1. Connector for RS-232C/RS-422/RS-485

Connector model: Hirose Electric Co., Ltd. RDED-9P-LN (4-40) (50)

Please select one out of RS-232C, RS-422 and RS-485.

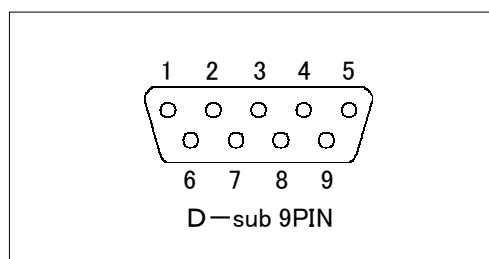

PIN No.	Signal name	note
1	NC	
2	TD	RS-232C transfer data
3	RD	RS-232C receive data
4	NC	
5	GND	Signal ground.
6	RD+	RS422 / RS485
7	RD-	
8	TD+	
9	TD-	↓

RS-232C uses the pins 2, 3 and 5.

RS-422 and RS-485 use the pins 5 through 9.

SW 1 on top of the unit can select either RS-422 or RS-485 and can either connect the termination resistors or disconnect them.

SW2 is the common switch for RS-232C, RS-422 and RS485 to set parameters of communication speed and so on.

Please refer to the next section for further detail.

5. SETTING SWITCHES

The functions of the dipswitches and a rotary switch are follows:

SW1	8bit DIP-SW	Set parameters of RS-422/485
SW2	8bit DIP-SW	Set transfer speed
SW3	8bit DIP-SW	Set communication parameters
SW4	3 sets of 16-step rotary switch	Own station address

table 5-1

Table 5-2 SW1 (DIP-8)

Item	bit	内 容	ON	OFF
Set D-sub connector Set termination resisters(RS-422/485)	1	Connect/disconnect TD+ and RD+	connected	open
	2	Connect/disconnect TD- and RD-	connected	open
	3	Connect/disconnect the resister between TD+ and TD-	connected	open
	4	Connect/disconnect the resister between RD+ and RD-	connected	open
	5	Connect/disconnect the pull-up resister to RD+	connected	open
	6	Connect/disconnect the pull-down resister to RD-	connected	open
	7	Set parameters of RS-422/485 reception driverRS-422/485	OFF during transmission	Normally ON
	8	Reserved		

The shadowed indicates the Ex-factory conditions

Figure 5-1 RS-422/485 interface circuitry

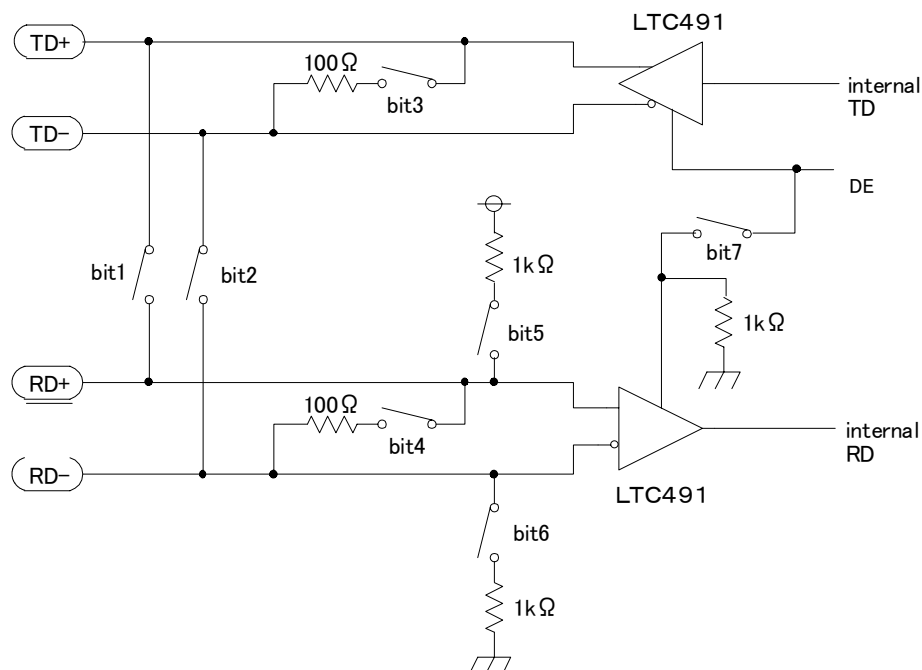

Table 5-3 SW2 (DIP-8)

Item	bit		ON	OFF
Set D-sub connector (wiring of RS-232C)	1	Select RS-232C or RS-422/485	RS-422/485	RS-232C
	2	1 packet user data length	Refer to table 4-4	
	3			
	4	Reserved		
Common for RS-422/485/232C	5	Transfer speed	Refer to table 4-5.	
	6	↓		
	7			
	8	Reserved		

The shadowed indicates the Ex-factory conditions.

Table 5-4 Setting of 1 packet user data length

No.	SW2		Number of user data bytes [BYTE]
	bit3	bit2	
1	OFF	OFF	8
2	OFF	ON	16
3	ON	OFF	32
4	ON	ON	64

The shadowed indicates the Ex-factory conditions.

Table 5-5 Setting of transfer speed

No.	SW2			Transfer speed [bps]
	bit7	bit6	bit5	
1	OFF	OFF	OFF	4800
2	OFF	OFF	ON	9600
3	OFF	ON	OFF	19200
4	OFF	ON	ON	38400
5	ON	OFF	OFF	57600
6	ON	OFF	ON	reserve
7	ON	ON	OFF	115200
8	ON	ON	ON	115200

The shadowed indicates the Ex-factory conditions.

Table 5-6 SW3 (DIP-8)

Item	bit	content	ON	OFF
Communication parameters	1	Data length	7	8
	2	Stop bit	2	1
	3	Parity	yes	none
	4	Parity even or odd	even	odd
	5	Software flow control	valid	Not valid
	6	Multi-connection or single connection with RS-422/485	multi	single
	7	Add "CR" and "LF" to reception data and output it to the external I/F	add	Not add
	8	Output packets to all mobile stations and the host computer	output	Not output

The shadowed indicates the Ex-factory conditions.

Table 5-7 SW4 (2 sets of 16-step rotary switch)

Item	Effective value	note
Own address	00h to FFh	Default value is 00h setting value 00h is address 100h automaticaly adding 100h

6.SYSTEM OPERATION

6-1. Outline of communication

FDK01TU010 is the wireless modem unit to communicate with FDK02TU010. To send data to FDK02TU010 through serial port(RS-232C, 485, 422) of FDK01TU010, apply command @TXT or @TBN. Refer to the instruction manual about detail of @TXT or @TBN command. Communications on the air through feeder line and coupler are performed with packet data transmission mode.

6-2. Preparation of communication on the air

Before making communication on the air with FDK02TU010, it is necessary to chose frequency and chose the port of two couplers of transmitter and reciever. The frequency of each FDK01TU010 and FDK02TU010 must be same.

6-3. Data communication with serial port of the wireless modem

6-3-1.Transmission

To send data to FDK02TU010 through serial port(RS-232C, 485, 422) of FDK01TU010, apply command @TXT or @TBN. If there was respond ACK from FDK02TU010 on the air, FDK01TU010 make OK output to its serial port(RS-232C, 485, 422). If ther was no ACK from FDK02TU010 on the air, then FDK01TU010 make twice retransmission of normal packet on the air. And on third to fifth retransmission, FDK01TU010 transmits BCH mode packet. After all, there was no ACK from FDK02TU010, then FDK01TU010 make NG output through its serial port(RS-232C, 485, 422).

6-3-2.Recieving

FDK01TU010 recognise packet mode of FDK02TU010 from which is normal or BCH automatically, then calculate CRC and make address recognition and make data output through its serial port(RS-232C, 485, 422).

6-3-3.Data packet format

Data packet format is described below.

Preamble	Header	Data	CRC
----------	--------	------	-----

Preamble : 32 times repetition of 1 and 0.

Header : address of recipient, and adress of transmitter, nuber of retransumission, nuber of packet, and so on.

Data : data to be sent up to 1024 bytes.

CRC : CRC16 caluculated with Header to Data.

6-3-4.Communication on 1:n mode

One FDK01TU010 able to perform 1:n communication with defined number of FDK02TU010. To make 1:n communication, define plural address on address part of @TXT or @TBN command. Addresses input through serial port(RS-232C, 485, 422) of FDK01TU010 will be added to its header.

7. COMMUNICATION WITH MOBILE STATIONS

Communication procedure (an example)

Set parameters of fixed station, and make it effective to communicate with mobile stations.

Connect to the power source.

Connect the external interface (One of RS-232C, RS422 and RS485)

Connect to the matching/distributing unit.

(The order between and can be changed freely.)

Turn on the fixed station and mobile stations.

(The order to turn on the powers is free.)

Wait more than 1 second and then set frequency channel.

After receiving a response of "OK", forward to the next step.

Send command/data in format of @TXT or @TBN.

If "OK" is returned, the communication is completed.

If "NG" is returned, possible reasons of the failure are insufficient signal strength and improper settings of communication cable, switches and frequencies.

Send @PNG command and read the value of RSSI. If the value is 57 or larger, please confirm the setting condition again.

If "OK" is returned, it is possible to continue communication by repeating .

8. COMMUNICATION COMMAND

Input and output between external control equipment and mobile stations are carried out by packet method.

The data format of the packet method is either in the sequence of "@TXT (address) (user data) [CR][LF]" or in the sequence of "@TBN (address) (data length) (user data)"

Binary data method is useful to avoid communication errors when a control code matches exactly a part of user data.

Text data @TXT (address) (user data) [CR][LF]

Address : ASCII code, hexadecimal 3-digits
(For instance, 4 is "34h" in ASCII.)

Data : ASCII code, hexadecimal

The data length : Arbitrary but no more than 1024 bytes.

[CR] : 0Dh in hexadecimal

[LF] : 0Ah in hexadecimal

Example : Sending "ABCDEFGH" to a mobile station whose address is 400.

@TXT400ABCDEFGH[CR][LF]

Binary data @TBN (address) (data length) (user data)

Address : ASCII code, hexadecimal 3-digits

Data length : "001" to "400" (0 to 1024 bytes)

The number of bytes should be expressed by hexadecimal 3-digits in ASCII code.

[CR][LF] : not necessary

If data length is longer than predetermined data length, the surplus of the data will slide in front of the next instruction. Therefore "NG[CR][LF]" may be returned to the data sender.

Example : Sending 7 bytes of binary data to a mobile station whose address is 400.

@TBN400007 (7 bytes of binary data)

Taking into consideration the manual input through terminal software, the text data method can delete a character by recognizing backspace key while the binary data method treats backspace key as data.

In the communication between the feeder cable and mobile stations, a packet is defined and transmitted as the number of user bytes that are set by bit2 and bit3 of the DIP SW2.

In the case that transmission and reception of all the data is completed properly, the sender will output the message "OK [CR][LF]" after receiving ACK of the last packet.

On the other hand, the receiver will output the same character string that was sent from the sender from the headfirst. In case of @TBN command, the receiver will output the data that is within the range determined by the user data length, otherwise surplus of the data will not be outputted.

In case of communication error, if ACK is not returned from the destination after repeating retransmission up to the preset number, the sender will stop sending data and output "NG [CR][LF]" immediately after detection of the end of input data.

In case of failure while sending a packet due to communication error, the sender will output the partial data that the sender could properly receive from the external interface of the receiver.

9. CONTROL COMMAND

Control commands are used for controlling the fixed station.

Command table

No.	Command string	content
1	FRQ	Write or read frequency channel number
2	PNG	Request response & read the reception intensity of the destination
3	SWR	Read switch information
4	RST	Reset software

@FRQ : Write or read frequency channel number

1) Input : @FRQpp[CR][LF]

pp : Input a number between 1 and 50 (ASCII code) or input nothing for pp.

(note)

Inputting a single digit is allowed for 1 through 9.

Do not input space between "FRQ" and "pp".

2) Processing : If there is no input for "pp", the current frequency channel number will be outputted.

Response message

FRQ = pp[CR][LF]

(note)

pp : 01 to 50 (ASCII code)

Spaces are necessary in front of and afterwards of "=".

: If a channel number is inputted in "pp", this modem will return "OK" message to the host computer after changing the SRAM register and reassign the frequency number,.

3) Frequency channel at the booting

At the booting this modem and resetting the software, the frequency channel is given by the setting by SW5 on the case top.

@PNG : Request response & read the reception intensity of the destination

1) Input : @PNG[CR][LF]

2) Processing : Receiving this command, this modem returns as a response message the signal intensity of the last packet that this modem has received.

Response message

RSSI = nn[CR][LF]

nn : Hexadecimal number of signal intensity in [dBm]

@SWR : Read switch information

1) Input : @SWR[CR][LF]

2) Processing : Receiving this command, this modem outputs information related to its switches of SW2 through SW5. SW1 has no function to send its information.

SW2 : Binary, 8 digits (0: OFF, 1:ON BIT8 is in the far left.)

SW3 : Binary, 8 digits (0: OFF, 1:ON BIT8 is in the far left.)

SW4 : Hexadecimal, 2 digits (The lower 2 digits of address)

SW5 : Hexadecimal, 2 digits

In case of the fixed station, this figure shows the setting condition of its channel switches.

The most significant digit of the mobile station address corresponds to the rotary switch in the far right of the SW5.

@RST : Reset software

1) Input : @RST[CR][LF]

2) Processing : Receiving this command, software will be reset.

This command restarts the exerciser program from the start address.

Also the SRAM register will be reset to the condition when this modem was turned on.

In addition, this command will initialize not only the software but also the hardware of this modem.

It takes about 300ms.

After the completion of initialization, a response message of "OK" will be returned to the host computer.

10. ADDRESS

The effective addresses for the fixed station are from 100 through 1FF while the third digit is always fixed to "1".

Use rotary switch SW4 for setting.

Set the address at "001" when sending data to the fixed station from mobile stations.

The address setting of the fixed station is required only for the host computer to send control command to the specific one of the fixed stations that are connected in multi-drop fashion. No specific address is necessary in case sending data from mobile stations, because there exists only one fixed station.

11. INDICATORS

POWER	When green LED is on, the power is on.
DOWN LINK	When green LED is off, there is no packet. When green LED is on, packets have been sent to feeder cables.
UP LINK RX LEVEL	Combinations of eight LEDs indicate the levels of the signal intensity. 2 Red LEDs ON : < or =-90dBm 2 Red and 1 Orange LEDs : < or =-85dBm 2 Red and 2 Orange LEDs : < or =-80dBm 2 Red, 2 Orange 1 Green LEDs : < or =-75dBm 2 Red, 2 Orange 2 Green LEDs : < or =-70dBm 2 Red, 2 Orange 3 Green LEDs : < or =-65dBm 2 Red, 2 Orange 4 Green LEDs : > -65dBm

12. EXTERNAL RESET

The following connector is equipped with this modem so that the hardware of this modem can be reset externally.

Connector type : J.S.T. Mfg Co., Ltd S3B-XH-SM3-TB

In order to reset this modem externally, short #2 and #3 pins of the RESET connector in the picture 11-1 more than 10ms: then disconnect them.

One of the terminals is connected to the internal power source and the other is to the ground line through 560ohm resistor respectively.

13. PRODUCT SPECIFICATION

13-1. communication characteristics of feeder cable

項 目	内 容
Up link frequency band (transmitter)	151 MHz ~ 156 MHz
Down link frequency band (receiver)	230 MHz ~ 235 MHz
Frequency band per channel	100 kHz
Interval between frequency channels	100 kHz
Number of frequency channels	50
Emission power	FCC part15 ClassB 46dB μ V/m at 3m
Reception signal intensity	-87dBm (at 100kbs, BER 10^{-4})
Addresses for mobile modems (own address)	400h ~ 9FFh(1536 addresses)
Communication speed	100 kbps
Communication mode	Full-Duplex Packet mode
Error detection/correction	Combination of ARQ and BCH

13-2. external I/F specification

Item	Notes
Connector	D-sub 9 pins
Communication standards	RS-232C, RS-422, RS-485 (Specially defined pin assignments are used for this product.)
Communication speed	4800bps to 115.2kbps
Communication method	RS-232C,RS-422 Full-Duplex Packet mode
	RS-485 Full-Duplex Packet mode
others	Connect/disconnect signal lines Connect/disconnect terminator resistance for RS-422 and RS485

13-3. fixed station's general specification

Item	Notes
Voltage of the power source	DC 20V to 29V
Consumption power	3 W
Outer dimensions	102(D) x 116(W) x 35(H) mm
Weight	550g
Material of the chassis	Iron (1 mm thickness)
Surface treatment of the chassis and color	Surface treatment : Coating on bonded steel Color : DIC 546 1/2 (Dainippon Ink)
Operating temperature range	-10C to +50C
Storage temperature range	-20C to +70C
Operating humidity range	35%RH to 95%RH (under no condensation)
Storage humidity range	35%RH to 95%RH (under no condensation)
Anti-vibration	The product should survive the following vibration test; Vibration amplitude : 3.5mm Frequency : 10Hz 2 hours for back and forth 2 hours for left and right 4 hours for up and down
Anti-shock	The product should survive the following shock test; Acceleration : 500 m/s ² 3 times along with 3 axis, total 9 times 500 m/s ²
Anti-electro static	Apply following high voltage Input/output terminals : ± 1kV (contact discharge) Chassis : ± 5kV (non-contact discharge) There should be no malfunction after test. Chassis : ± 10kV (non-contact discharge) There should be no damage after test. The test follows JASO-D-001-94 5.8 (A-2,B-2,C-2)

14. FREQUENCY CHANNEL

Channel No.	Frequency		Channel No.	Frequency	
	Down-link [MHz]	Up-link [MHz]		Down-link [MHz]	Up-link [MHz]
1	230.05	151.05	26	232.55	153.55
2	230.15	151.15	27	232.65	153.65
3	230.25	151.25	28	232.75	153.75
4	230.35	151.35	29	232.85	153.85
5	230.45	151.45	30	232.95	153.95
6	230.55	151.55	31	233.05	154.05
7	230.65	151.65	32	233.15	154.15
8	230.75	151.75	33	233.25	154.25
9	230.85	151.85	34	233.35	154.35
10	230.95	151.95	35	233.45	154.45
11	231.05	152.05	36	233.55	154.55
12	231.15	152.15	37	233.65	154.65
13	231.25	152.25	38	233.75	154.75
14	231.35	152.35	39	233.85	154.85
15	231.45	152.45	40	233.95	154.95
16	231.55	152.55	41	234.05	155.05
17	231.65	152.65	42	234.15	155.15
18	231.75	152.75	43	234.25	155.25
19	231.85	152.85	44	234.35	155.35
20	231.95	152.95	45	234.45	155.45
21	232.05	153.05	46	234.55	155.55
22	232.15	153.15	47	234.65	155.65
23	232.25	153.25	48	234.75	155.75
24	232.35	153.35	49	234.85	155.85
25	232.45	153.45	50	234.95	155.95