

# EMI TEST REPORT

**Test Report No.: 25IE0087-HO-1**

**Applicant** : CANON INC.  
**Type of Equipment** : WLAN module for printer  
**Model No.** : K30254  
**Test standard** : FCC Part 15 Subpart C  
Section 15.207, Section 15.247: 2005  
**FCC ID** : AZDK30254  
**Test Result** : **Complied**

1. This test report shall not be reproduced in full or partial, without the written approval of UL Apex Co., Ltd.
2. The results in this report apply only to the sample tested.
3. This equipment is in compliance with the above regulation. We hereby certify that the data contain a true representation of the EMC profile.
4. The test results in this report are traceable to the national or international standards.

**Date of test:** June 9 to June 20, 2005

**Tested by:**



Makoto Kosaka  
EMC Service



Norihisa Hashimoto  
EMC Service



Kenichi Adachi  
EMC Service

**Approved by :**

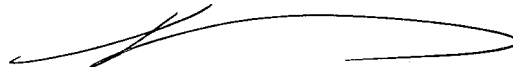

Naoki Sakamoto  
Group Leader of  
EMC Service

**UL Apex Co., Ltd.**

**Head Office EMC Lab.**

4383-326 Asama-cho, Ise-shi, Mie-ken 516-0021 JAPAN

Telephone : +81 596 24 8116

Facsimile : +81 596 24 8124

MF060b(01.06.05)

<b>CONTENTS</b>	<b>PAGE</b>
<b>SECTION 1: Client information</b> .....	<b>3</b>
<b>SECTION 2: Equipment under test (E.U.T.)</b> .....	<b>3</b>
<b>SECTION 3: Test specification, procedures &amp; results</b> .....	<b>5</b>
<b>SECTION 4: Operation of E.U.T. during testing</b> .....	<b>7</b>
<b>SECTION 5: Conducted Emission</b> .....	<b>9</b>
<b>SECTION 6: Spurious Emission</b> .....	<b>10</b>
<b>SECTION 7: 6dB Bandwidth</b> .....	<b>11</b>
<b>SECTION 8: Maximum Peak Output Power</b> .....	<b>11</b>
<b>SECTION 9: Peak Power Density</b> .....	<b>11</b>
<b>APPENDIX 1: Photographs of test setup</b> .....	<b>12</b>
Conducted Emission .....	12
Spurious Emission (Radiated).....	13
Worst Case Position (Z-axis:Horizontal / Z-axis:Vertical) .....	14
<b>APPENDIX 2: Test instruments</b> .....	<b>15</b>
<b>APPENDIX 3: Data of EMI test</b> .....	<b>16</b>
Conducted Emission .....	16
6dB Bandwidth(DSSS and other forms of modulation).....	17
Maximum Peak OutPut Power (DSSS and other forms of modulation).....	20
Radiated Spurious Emission(DSSS and other forms of modulation ) (below 1GHz).....	23
Radiated Spurious Emission(DSSS and other forms of modulation) (above 1GHz).....	29
Conducted Spurious Emission(DSSS and other forms of modulation) .....	35
Conducted Spurious Emission(DSSS and other forms of modulation).....	38
Conducted emission Band Edge compliance (DSSS and other forms of modulation) .....	41
Power Density (DSSS and other forms of modulation ).....	42
99%Occupied Bandwidth(DSSS and other forms of modulation) .....	45
<b>APPENDIX 4: Reference data [Characteristic and destructive tests]</b> .....	<b>47</b>

## **SECTION 1: Client information**

Company Name : CANON INC.  
Address : 451, Tsukagoshi 3-chome, Saiwai-ku, Kawasaki-shi, Kanagawa  
212-8530, Japan  
Telephone Number : +81-44-542-0164  
Facsimile Number : +81-44-542-7524  
Contact Person : Keiji Kawata

## **SECTION 2: Equipment under test (E.U.T.)**

### **2.1 Identification of E.U.T.**

Type of Equipment : WLAN module for printer  
Model No. : K30254  
Serial No. : 08F2E2 (Spurious Emission(Radiated) and Other tests)  
08F2F2 (Conducted emission)  
Rating : DC3.35V(Operating)+/- 7%, DC1.8V,2.9V,3.3V(Inner)  
Country of Manufacture : Japan  
Receipt Date of Sample : May 30, 2005  
Condition of EUT : Production prototype  
(Not for Sale: This sample is equivalent to mass-produced items.)

---

**UL Apex Co., Ltd.**

**Head Office EMC Lab.**

4383-326 Asama-cho, Ise-shi, Mie-ken 516-0021 JAPAN

Telephone : +81 596 24 8116

Facsimile : +81 596 24 8124

MF060b(01.06.05)

## 2.2 Product Description

Model No: K30254 (referred to as the EUT in this report) is IEEE802.11b/g Wireless LAN module for printer.

		IEEE802.11b/g Wireless LAN
<b>Equipment Type</b>		Transceiver
<b>Frequency band</b>	<b>Lower limit</b>	2412MHz
	<b>Upper limit</b>	2462MHz
<b>Channel spacing</b>		5MHz
<b>Type of Modulation</b>		DSSS/OFDM
<b>Clock frequency in the system</b>		MCU:12MHz, WLAN chip: 40MHz, LAN PHY chip: 25MHz
<b>Antenna Type</b>		Chip Dielectric Antenna
<b>Antenna Connector Type</b>		Microwave Coaxial Connector
<b>Antenna Gain</b>		1.44 dBi max
<b>Mode of Operation</b>		Simplex
<b>ITU code</b>		G1D
<b>Power Supply</b>		DC3.35V(Operating)+/- 7% DC1.8V,2.9V,3.3V(Inner)

### FCC 15.31 (e)

Power source, DC3.35V of EUT is supplied from the printer in which the EUT is installed. The following three voltages are supplied with RF module part.

- 3.3V (not regulated)
- 2.9V (regulated)
- 1.8V (regulated)

Testing of the variation of the input power was performed and complied with this requirement. As for the detail, please refer to APPENDIX 4.

### FCC Part 15.203 Antenna requirement

The antenna is not removable from EUT. Therefore the equipment complies with the antenna requirement of Section 15.203.

**UL Apex Co., Ltd.**

**Head Office EMC Lab.**

4383-326 Asama-cho, Ise-shi, Mie-ken 516-0021 JAPAN

Telephone : +81 596 24 8116

Facsimile : +81 596 24 8124

MF060b(01.06.05)

**SECTION 3: Test specification, procedures & results**

**3.1 Test Specification**

Test Specification : FCC Part15 Subpart C : 2005  
Title : FCC 47CFR Part15 Radio Frequency Device Subpart C Intentional Radiators  
Section 15.207 Conducted limits: 2005  
Section 15.247 Operation within the bands 902-928MHz, 2400-2483.5MHz, and 5725-5850MHz: 2005

**3.2 Procedures and results**

No.	Item	Test Procedure	Specification	Remarks	Deviation	Worst margin	Results
1	Conducted emission	ANSI C63.4:2003 7. AC powerline conducted emission measurements	Section 15.207 RSS-210 6.6	-	N/A	4.0 dB 0.2440MHz, QP, L	Complied
2	6dB Bandwidth	ANSI C63.4:2003 13. Measurement of intentional radiators	Section 15.247(a)(2) RSS-210 5.9.1	Conducted	N/A	See data.	Complied
3	Maximum Peak Output Power	ANSI C63.4:2003 13. Measurement of intentional radiators	Section 15.247(b)(3) RSS-210 6.2.2(o)(b)	Conducted	N/A		Complied
4	Spurious Emission	ANSI C63.4:2003 13. Measurement of intentional radiators	Section 15.247 (d) RSS-210 6.2.2(o)(e)(e1) and 6.3	Conducted/ Radiated	N/A	1.7dB 325.716MHz, Vertical, QP	Complied
5	Restricted Band Edges	ANSI C63.4:2003 13. Measurement of intentional radiators	Section 15.247 (d) RSS-210 6.2.2(o)(e)(e1) and 6.3	Conducted	N/A	See data	Complied
6	Power Density	ANSI C63.4:2003 13. Measurement of intentional radiators	Section 15.247 (e) RSS-210 6.2.2(o)(b)	Conducted	N/A		Complied

Note: UL Apex's EMI Work Procedures No.QPM05 and QPM15.

**Uncertainty:**

Conducted Emission

The measurement uncertainty (with a 95% confidence level) for this test is ±1.3dB.  
The data listed in this test report has enough margin, more than the site margin.

Spurious Emission (Radiated)

The measurement uncertainty (with a 95% confidence level) for this test using Biconical antenna is ±4.5dB(3m)/ ±4.7dB(10m).  
The measurement uncertainty (with a 95% confidence level) for this test using Logperiodic antenna is ±5.2dB(3m)/ ±3.8dB(10m).  
The measurement uncertainty (with a 95% confidence level) for this test using Horn antenna is ±6.6dB.  
The data listed in this report meets the limits unless the uncertainty is taken into consideration.

Other test except Conducted Emission and Spurious Emission (Radiated)

The measurement uncertainty (with a 95% confidence level) for this test is ±3.0dB.

\*These tests were also referred to "Guidance on Measurement for Digital Transmission Systems Section15.247".

\*These tests were performed without any deviations from test procedure except for additions or exclusions.

**UL Apex Co., Ltd.**

**Head Office EMC Lab.**

4383-326 Asama-cho, Ise-shi, Mie-ken 516-0021 JAPAN

Telephone : +81 596 24 8116

Facsimile : +81 596 24 8124

MF060b(01.06.05)

### 3.3 Addition to standards

No.	Item	Test Procedure	Specification	Remarks	Deviation	Worst margin	Results
1	99% Occupied Band Width	RSS-210 (issue 5): 2001 + Amendment:2002 + Amendment2:2003 + Amendment3:2004 + Amendment4: 2004	RSS-210 (issue 5): 2001 + Amendment:2002 + Amendment2:2003 + Amendment3:2004 + Amendment4: 2004	Conducted	N/A	N/A	N/A

### 3.4 Test Location

UL Apex Co., Ltd. Head Office EMC Lab. \*NVLAP Lab. code: 200572-0  
4383-326 Asama-cho, Ise-shi, Mie-ken 516-0021 JAPAN  
Telephone : +81 596 24 8116  
Facsimile : +81 596 24 8124

	FCC Registration Number	IC Registration Number	Width x Depth x Height (m)	Size of reference ground plane (m) / horizontal conducting plane	Other rooms
No.1 semi-anechoic chamber	313583	IC4247A	19.2 x 11.2 x 7.7m	7.0 x 6.0m	Preparation room
No.2 semi-anechoic chamber	846015	IC4247A-2	7.5 x 5.8 x 5.2m	4.0 x 4.0m	-
No.3 shielded room	-	-	4.7 x 7.5 x 2.7m	4.7 x 7.5m	-
No.4 measurement room	-	-	3.1 x 5.0 x 2.7m	N/A	-

\* Size of vertical conducting plane (for Conducted Emission test) : 2.0 x 2.0m for No.1 and No.2 semi-anechoic and No.3 shielded room.

### 3.5 Test set up, Test instruments and Data of EMI

Refer to APPENDIX 1 to 3.

## SECTION 4: Operation of E.U.T. during testing

### 4.1 Operating Modes

The mode is used :  
1) Wireless LAN Printing mode for Configuration 1 (for Conducted emission test)  
2) The following modes are for Configuration 2 (for other tests)

**IEEE 802.11b : CCK (QPSK, 11Mbps)**

-Transmitting mode

Low channel : 2412MHz  
Middle channel : 2437MHz  
High channel : 2462MHz

**IEEE 802.11g : OFDM(64QAM, 54Mbps)**

-Transmitting mode

Low channel : 2412MHz  
Middle channel : 2437MHz  
High channel : 2462MHz

### 4.2 Configuration and peripherals

【Configuration 1 (for Conducted emission test)】

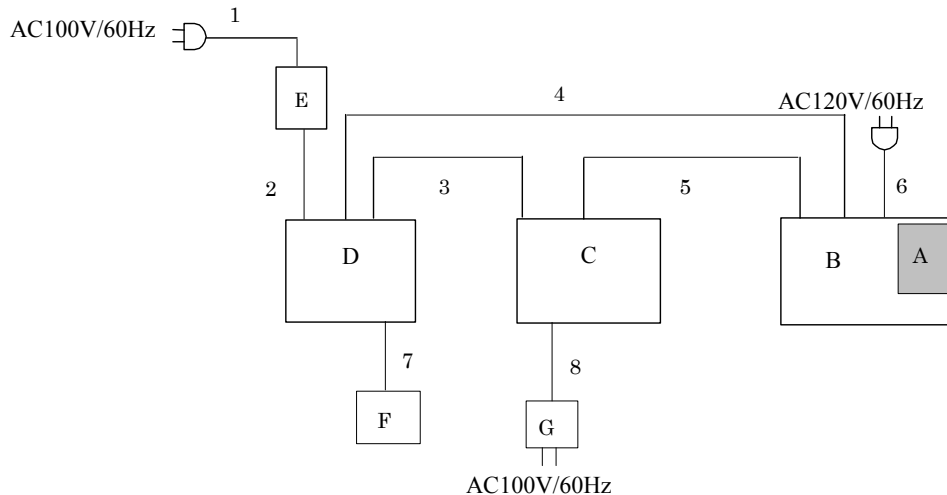

\* Cabling was taken into consideration and test data was taken under worse case conditions.

**UL Apex Co., Ltd.**

**Head Office EMC Lab.**

4383-326 Asama-cho, Ise-shi, Mie-ken 516-0021 JAPAN

Telephone : +81 596 24 8116

Facsimile : +81 596 24 8124

MF060b(01.06.05)

【Configuration 2 (for other tests)】

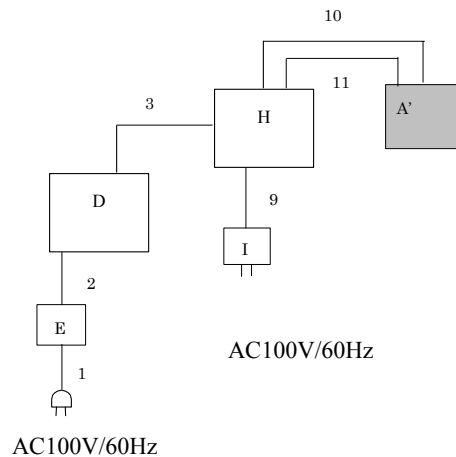

\* Cabling was taken into consideration and test data was taken under worse case conditions.  
\* In Radiated Spurious Emission testing, D,E,1,2,3 was removed after radio parameter setting, and then a plug was connected with I (AC Adapter).

**Description of EUT and Support equipment**

No.	Item	Model number	Serial number	Manufacturer	FCC ID
A	WLAN for printer (EUT)	K30254	08F2F2	CANON	AZDK30254
A'	WLAN for printer (EUT)	K30254	08F2E2	CANON	AZDK30254
B	Ink Jet Printer	K10253	0001	CANON	
C	Access Point	WLBAR-54GT	0056710030606085	Corega	
D	Notebook PC	FMVMG10 AC	R2600274	FUJITSU	
E	AC Adapter	FMV-AC311S	025455874A	FUJITSU	
F	Headphone microphone	-	-	-	
G	AC Adapter	UL110-1210	CFB	Unifive	
H	Jig	-	-		
I	AC Adapter	NT24-ISO540	01103	Go Forwarded Enterprise	

**List of cables used**

No.	Name	Length (m)	Shield	Backshell Material
1	AC Cable	2.0	N	Polyvinyl chloride
2	DC Cable	1.8	N	Polyvinyl chloride
3	LAN Cable	3.0	N	Polyvinyl chloride
4	USB Cable	1.0	Y	Polyvinyl chloride
5	LAN Cable	1.0	N	Polyvinyl chloride
6	AC Cable	1.7	N	Polyvinyl chloride
7	Headphone Cable	1.8	N	Polyvinyl chloride
8	DC Cable	1.85	N	Polyvinyl chloride
9	DC Cable	1.6	N	Polyvinyl chloride
10	DC and Signal cable	0.2	N	Polyvinyl chloride
11	DC and Signal cable	0.2	N	Polyvinyl chloride

**UL Apex Co., Ltd.**

**Head Office EMC Lab.**

4383-326 Asama-cho, Ise-shi, Mie-ken 516-0021 JAPAN

Telephone : +81 596 24 8116

Facsimile : +81 596 24 8124

MF060b(01.06.05)



## **SECTION 5: Conducted Emission**

### **Test Procedure and conditions**

EUT was placed on a platform of nominal size, 1m by 1.5m, raised 80cm above the conducting ground plane. The rear of tabletop was located 40cm to the vertical conducting plane. The rear of EUT, including peripherals aligned and flushed with rear of tabletop. All other surfaces of tabletop were at least 80cm from any other grounded conducting surface. EUT was located 80cm from a Line Impedance Stabilization Network (LISN)/ Artificial mains Network (AMN) and excess AC cable was bundled in center.

#### **1) For the tests on EUT with other peripherals (as a whole system)**

I/O cable and AC cables that were connected to the peripherals were bundled in center. They were folded back and forth forming a bundle 30cm to 40cm long and were hanged at a 40cm height to the ground plane.

#### **2) For the tests on EUT itself (as a stand alone equipment)**

Each EUT current-carrying power lead, except the ground (safety) lead, was individually connected through a LISN/(AMN) to the input power source. All unused 50ohm connectors of the LISN(AMN) were resistivity terminated in 50ohm when not connected to the measuring equipment.

The AC Mains Terminal Continuous disturbance Voltage has been measured with the EUT in a Semi Anechoic Chamber or a Measurement Room.

The EUT was connected to a LISN (AMN).

An overview sweep with peak detection has been performed.

**Detector** : CISPR quasi-peak and average detector (IF BW 9 kHz)  
**Measurement range** : 0.15-30MHz  
**Test data** : APPENDIX 3  
**Test result** : Pass

---

**UL Apex Co., Ltd.**

**Head Office EMC Lab.**

4383-326 Asama-cho, Ise-shi, Mie-ken 516-0021 JAPAN

Telephone : +81 596 24 8116

Facsimile : +81 596 24 8124

MF060b(01.06.05)

## **SECTION 6: Spurious Emission**

**[Conducted]**

### **Test Procedure**

The Out of Band Emission was measured with a spectrum analyzer connected to the antenna port.

**Test data** : APPENDIX 3  
**Test result** : Pass

**[Radiated]**

### **Test Procedure**

EUT was placed on a platform of nominal size, 0.5m by 1.0m, raised 80cm above the conducting ground plane. The Radiated Electric Field Strength intensity has been measured in a Semi Anechoic Chamber with a ground plane and at a distance of 3m(Below 10GHz) and 1m(Upper 10GHz).

The height of the measuring varied between 1 and 4m and EUT was rotated a full revolution in order to obtain the maximum value of the electric field intensity.

The measurements were performed for both vertical and horizontal antenna polarization with the Test Receiver, or the Spectrum Analyzer (in linear mode).

The test was made with the detector (RBW/VBW) in the following table.

When using Spectrum analyzer, the test was made with adjusting span to zero by using peak hold.

In any 100kHz bandwidth outside the frequency band in which the spread spectrum intentional radiator is operating, the radio frequency power that is produced by the intentional radiator confirmed 20dB below that in the 100kHz bandwidth within the band that contains the highest level of the desired power, based on a radiated measurement.

### **20dBc was applied to the frequency over the limit of FCC 15.209 and outside the restricted band of 15.205.**

Frequency	Below 1GHz	Above 1GHz
Instrument used	Test Receiver / Spectrum Analyzer	Spectrum Analyzer
Detector	QP: BW 120kHz(T/R)	PK: RBW:1MHz/VBW: 1MHz
IF Bandwidth	20dBc : RBW: 100kHz VBW: 300kHz (S/A)	AV: RBW:1MHz/VBW:10Hz 20dBc : RBW:100kHz/VBW:300kHz

**Test data** : APPENDIX 3  
**Test result** : Pass

- The carrier level and noise levels were confirmed at each position of X, Y and Z axes of EUT to see the position of maximum noise, and the test was made at the position that has the maximum noise.

---

**UL Apex Co., Ltd.**

**Head Office EMC Lab.**

4383-326 Asama-cho, Ise-shi, Mie-ken 516-0021 JAPAN

Telephone : +81 596 24 8116

Facsimile : +81 596 24 8124

MF060b(01.06.05)

## **SECTION 7: 6dB Bandwidth**

### **Test Procedure**

The bandwidth was measured with a spectrum analyzer connected to the antenna port.

**Test data** : APPENDIX 3  
**Test result** : Pass

## **SECTION 8: Maximum Peak Output Power**

### **Test Procedure**

The test was made with the spectrum analyzer that has a function of channel-power measurements.  
The Maximum Peak Output Power was measured with a spectrum analyzer connected to the antenna port.

**Test data** : APPENDIX 3  
**Test result** : Pass

## **SECTION 9: Peak Power Density**

[Conducted]

### **Test Procedure**

The Peak Power Density was measured with a spectrum analyzer connected to the antenna port.

**Test data** : APPENDIX 3  
**Test result** : Pass

---

**UL Apex Co., Ltd.**

**Head Office EMC Lab.**

4383-326 Asama-cho, Ise-shi, Mie-ken 516-0021 JAPAN

Telephone : +81 596 24 8116

Facsimile : +81 596 24 8124

MF060b(01.06.05)

**APPENDIX 1: Photographs of test setup**

**Conducted Emission**

This page has been submitted for a separate exhibit.

**Spurious Emission (Radiated)**

This page has been submitted for a separate exhibit.

**Worst Case Position (Z-axis:Horizontal / Z-axis:Vertical)**

This page has been submitted for a separate exhibit.

## APPENDIX 2: Test instruments

### EMI test equipment

Control No.	Instrument	Manufacturer	Model No	Test Item	Calibration Date * Interval(month)
MAEC-02	Anechoic Chamber	TDK	Semi Anechoic Chamber 3m	1,2	2005/04/11 * 12
MRENT-14	Spectrum Analyzer	Advantest	R3273	2	2005/02/21 * 12
MHA-06	Horn Antenna	Schwarzbeck	BBHA9120D	2	2005/01/10 * 12
MCC-04	Microwave Cable 1G-50GHz	Storm	421-011 ( 90-1394-079 )	2	2005/01/05 * 12
MCC-19	Microwave Cable 1G-26.5GHz	Suhner	SUCOFLEX 104	2	2005/02/03 * 12
MPA-01	Pre Amplifier	Agilent	8449B	2	2005/02/05 * 12
MHF-02	High Pass Filter	Tokimec	TF323DCA	2	2004/09/18 * 12
MAEC-01	Anechoic Chamber	TDK	Semi Anechoic Chamber 10m	1,2	2004/11/13 * 12
MCC-01	Coaxial Cable 0.1-3000MHz	Suhner/storm/Agilent/TSJ	-	2	2004/12/19 * 12
MTR-01	Test Receiver	Rohde & Schwarz	ESI40	1,2	2004/11/12 * 12
MPA-04	Pre Amplifier	Agilent	8447D	2	2005/05/24 * 12
MBA-01	Biconical Antenna	Schwarzbeck	BBA9106	2	2004/10/14 * 12
MLA-01	Logperiodic Antenna	Schwarzbeck	USLP9143	2	2004/10/14 * 12
MAT-06	Attenuator(6dB)	Weinschel Corp	2	2	2004/12/16 * 12
MHA-02	Horn Antenna	EMCO	3160-09	2	2005/01/10 * 12
MSA-03	Spectrum Analyzer	Agilent	E4448A	3 to 6	2005/06/03 * 12
MAT-22	Attenuator(10dB)(above 1GHz)	Orient Microwave	BX10-0476-00	3 to 6	2005/03/16 * 12
MCC-15	Microwave Cable	Suhner	SUCOFLEX 104	3 to 6	2005/02/03 * 12
MDPS-04	DC Power Supply	KENWOOD TMI	PW18-1.3AT	5	Pre Check
MLS-02	LISN(AMN)	Schwarzbeck	NSLK8127	1(EUT)	2004/11/10 * 12
MLS-03	LISN(AMN)	Schwarzbeck	NSLK8127	1	2004/11/10 * 12
MCC-03	Coaxial Cable	Fujikura/Suhner/Agilent/TSJ	-	1	2004/12/24 * 12
MTA-01	Termination	TME	CT-01	1	2005/02/03 * 12

All equipment is calibrated with traceable calibrations. Each calibration is traceable to the national or international standards.

#### Test Item:

- 1: AC Main Conducted Emission
- 2: Radiated Spurious Emission
- 3: Maximum Peak Output Power
- 4: 6dB Bandwidth [DSSS]
- 5: Peak Output Power Density [DSSS]
- 6: Antenna Terminal Conducted Spurious Emission

**UL Apex Co., Ltd.**

**Head Office EMC Lab.**

4383-326 Asama-cho, Ise-shi, Mie-ken 516-0021 JAPAN

Telephone : +81 596 24 8116

Facsimile : +81 596 24 8124

MF060b(01.06.05)

**APPENDIX 3: Data of EMI test**

**Conducted Emission**

**DATA OF CONDUCTED EMISSION TEST**

UL Apex Co., Ltd. Head Office EMC Lab. No.1 Semi Anechoic Chamber  
Date : 2005/06/20 15:41:20

Applicant : CANON INC  
Kind of EUT : WLAN module for printer  
Model No. : K30254  
Serial No. : 08F2F2

Report No. : 25IE0087-HO  
Power : AC120V/60Hz (EUT DC3.35V)  
Temp°C/Humi% : 26deg. C / 54%  
Operator : Makoto Kosaka

Mode / Remarks : Wireless LAN Printing

LIMIT : FCC15C § 15.207 (QP)  
FCC15C § 15.207 (AV)

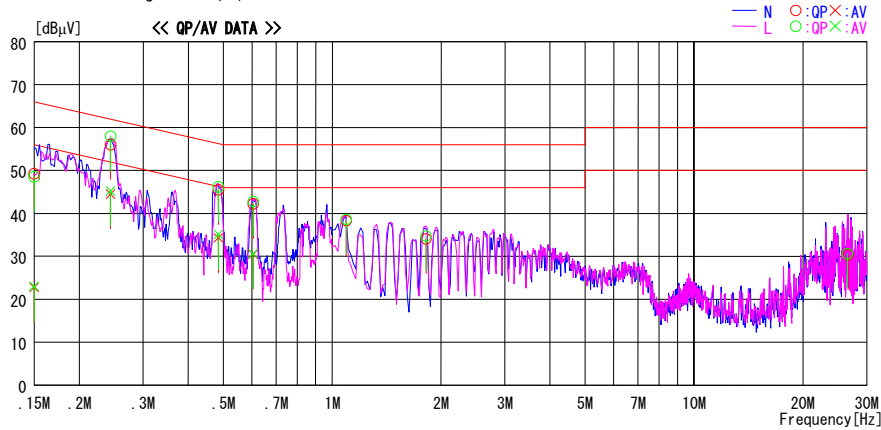

NO	FREQ [MHz]	READING		C. F [dB]	RESULT		LIMIT		MARGIN		PHASE
		QP [dBµV]	AV [dBµV]		QP [dBµV]	AV [dBµV]	QP [dB]	AV [dB]	QP [dB]	AV [dB]	
1	0.1500	48.9	22.5	0.3	49.2	22.8	66.0	56.0	16.8	33.2	N
2	0.2440	55.5	44.0	0.5	56.0	44.5	62.0	52.0	6.0	7.5	N
3	0.4842	45.1	33.9	0.4	45.5	34.3	56.3	46.3	10.8	12.0	N
4	0.6045	41.7	29.9	0.6	42.3	30.5	56.0	46.0	13.7	15.5	N
5	1.0922	37.8	---	0.5	38.3	---	56.0	---	17.7	---	N
6	1.8156	33.5	---	0.6	34.1	---	56.0	---	21.9	---	N
7	26.6152	27.6	---	2.7	30.3	---	60.0	---	29.7	---	N
8	0.1500	48.3	22.7	0.3	48.6	23.0	66.0	56.0	17.4	33.0	L
9	0.2440	57.5	44.7	0.5	58.0	45.2	62.0	52.0	4.0	6.8	L
10	0.4842	45.8	34.7	0.4	46.2	35.1	56.3	46.3	10.1	11.2	L
11	0.6045	42.2	30.0	0.6	42.8	30.6	56.0	46.0	13.2	15.4	L
12	1.0922	38.1	---	0.5	38.6	---	56.0	---	17.4	---	L
13	1.8156	34.1	---	0.6	34.7	---	56.0	---	21.3	---	L
14	26.6130	27.9	---	2.7	30.6	---	60.0	---	29.4	---	L

CHART: WITH FACTOR, Peak hold data. Data is uncorrected. CALCURATION: RESULT=READING+C. F (LISN LOSS+CABLE LOSS)  
Except for the above table : adequate margin data below the limits.



**[DSSS and other forms of modulation]**

**6dB Bandwidth(DSSS and other forms of modulation)**

UL Apex Co., Ltd.  
Head Office EMC Lab. No.3 Measurement Room

Company	: CANON INC.	REPORT NO	: 25IE0087-HO
Equipment	: WLAN module for printer	REGULATION	: Fcc Part15 Subpart C 15.247(a)(2)
Model	: K30254	TEST DISTANCE	: -
Sample No.	: 08F2E2	DATE	: 06/15/2005
Power	: DC 3.35V (AC adapter input AC120V/60Hz)	TEMPERATURE	: 25 deg.C.
Mode	: Tx(ch1,6,11)	HUMIDITY	: 51%
		ENGINEER	: Kenichi Adachi

**[IEEE802.11b] (11Mbps)**

Ch	Freq. [MHz]	6dB Bandwidth [MHz]	Limit [kHz]
Low	2412.0	11.557	500.0
Mid	2437.0	11.560	500.0
High	2462.0	11.555	500.0

**[IEEE802.11g] (54Mbps)**

Ch	Freq. [MHz]	6dB Bandwidth [MHz]	Limit [kHz]
Low	2412.0	16.517	500.0
Mid	2437.0	16.517	500.0
High	2462.0	16.510	500.0

**6dB Bandwidth(DSSS and other forms of modulation)**  
**11b, 11Mbps**

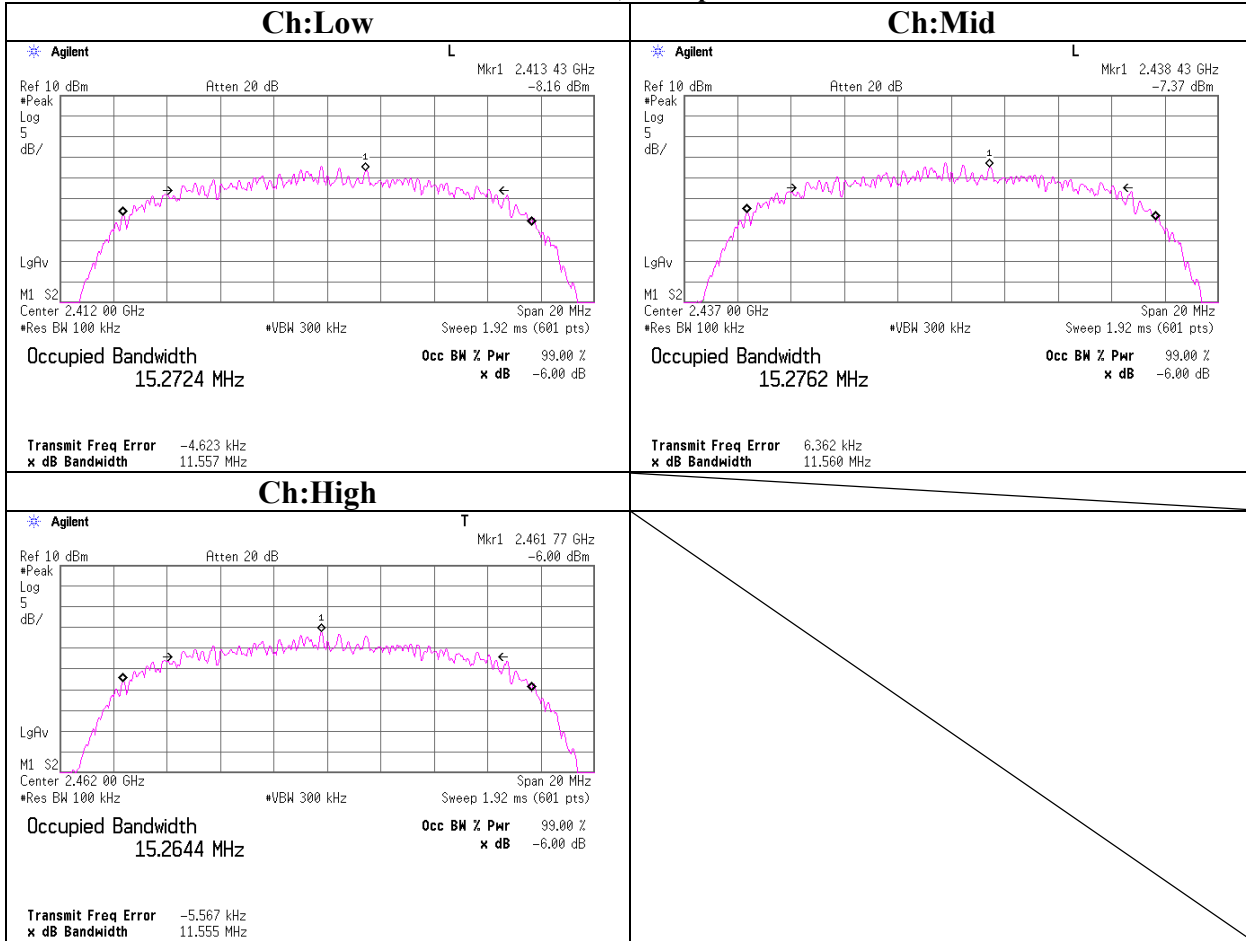

**6dB Bandwidth(DSSS and other forms of modulation)**  
**11g, 54Mbps**

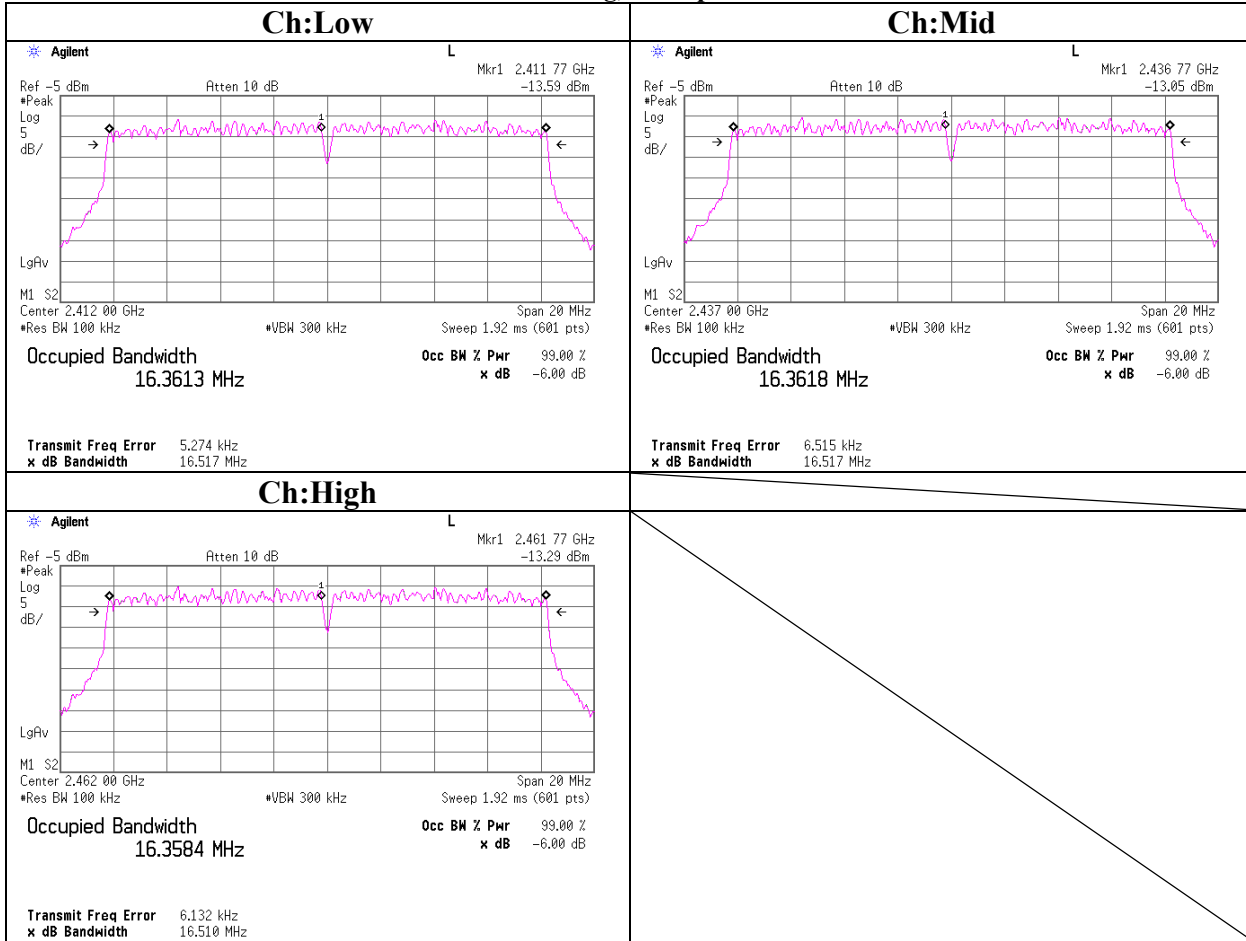

**Maximum Peak OutPut Power (DSSS and other forms of modulation)**

UL Apex Co., Ltd.  
Head Office EMC Lab. No.3 Measurement Room

Company	: CANON INC.	REPORT NO	: 25IE0087-HO
Equipment	: WLAN module for printer	REGULATION	: Fcc Part15 Subpart C 15.247(b)(3)
Model	: K30254	TEST DISTANCE	: -
Sample No.	: 08F2E2	DATE	: 06/15/2005
Power	: DC 3.35V (AC adapter input AC120V/60Hz)	TEMPERATURE	: 25 deg.C.
Mode	: Tx(ch1,6,11)	HUMIDITY	: 51%
		ENGINEER	: Kenichi Adachi

**[IEEE802.11b] (11Mbps)**

Ch	Freq. [MHz]	S/A Reading [dBm]	Cable Loss [dB]	Atten. [dB]	Result [dBm]	Limit (1W) [dBm]	Margin [dB]
Low	2412.0	8.46	0.93	9.91	19.30	30.00	10.70
Mid	2437.0	8.89	0.93	9.91	19.73	30.00	10.27
High	2462.0	9.26	0.93	9.91	20.10	30.00	9.90

Sample Calculation:

Result = Reading + Cable Loss (supplied by customer) + Attenuator

\* In the above table, factor 0.0dB represents no use of Atten. and/or Filter.

**[IEEE802.11g] (54Mbps)**

Ch	Freq. [MHz]	S/A Reading [dBm]	Cable Loss [dB]	Atten. [dB]	Result [dBm]	Limit (1W) [dBm]	Margin [dB]
Low	2412.0	9.53	0.93	9.91	20.37	30.00	9.63
Mid	2437.0	10.58	0.93	9.91	21.42	30.00	8.58
High	2462.0	10.70	0.93	9.91	21.54	30.00	8.46

Sample Calculation:

Result = Reading + Cable Loss (supplied by customer) + Attenuator

\* In the above table, factor 0.0dB represents no use of Atten. and/or Filter.

**UL Apex Co., Ltd.**

**Head Office EMC Lab.**

4383-326 Asama-cho, Ise-shi, Mie-ken 516-0021 JAPAN

Telephone : +81 596 24 8116

Facsimile : +81 596 24 8124

**Maximum Peak OutPut Power (DSSS and other forms of modulation)**  
**11b, 11Mbps**

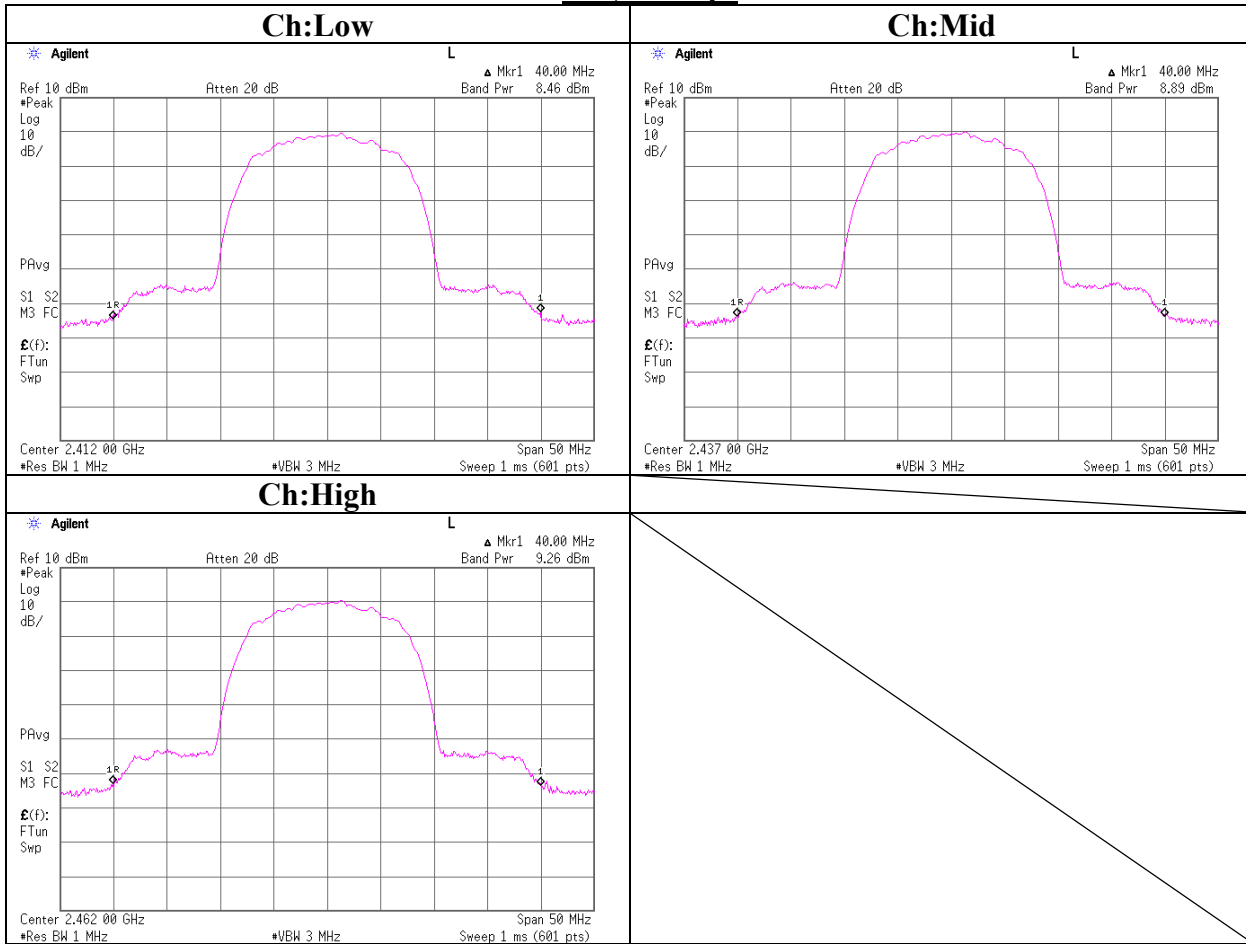

**Maximum Peak OutPut Power (DSSS and other forms of modulation)**  
**11g, 54Mbps**

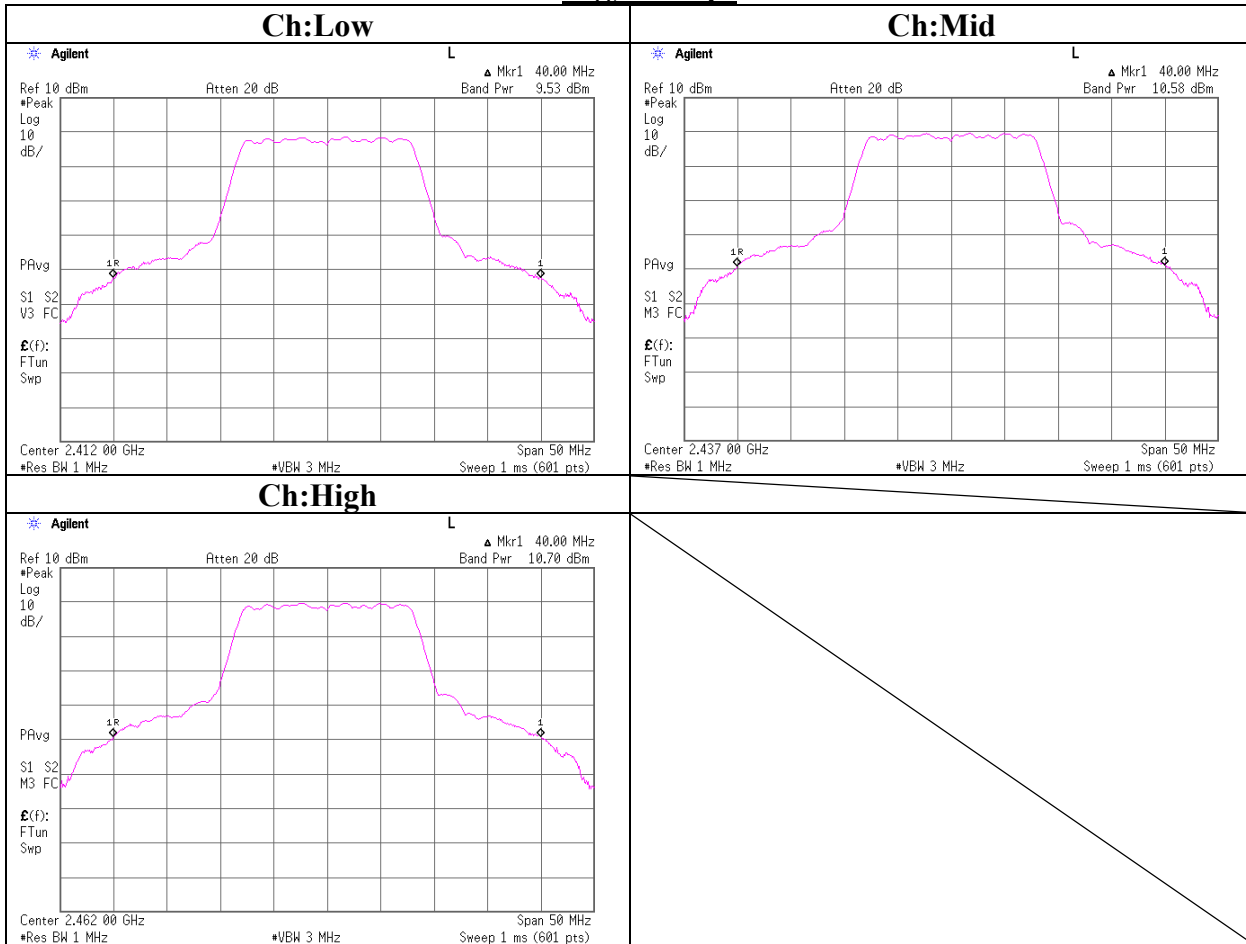

**Radiated Spurious Emission(DSSS and other forms of modulation ) (below 1GHz)**

\* The result is rounded off to the second decimal place. Therefore, there may be 0.1 difference for the result.

**DATA OF RADIATED EMISSION TEST**

UL Apex Co., Ltd. Head Office EMC Lab. No.1 Semi Anechoic Chamber

Applicant : CANON INC. Report No. : 25IE0087-HO  
Kind of EUT : WLAN module for printer Power : DC 3.35V  
Model No. : K30254 Temp°C/Humi% : 22deg.C / 52%  
Serial No. : 08F2E2 Operator : Norihisa Hashimoto

Mode / Remarks : IEEE802.11b 2412MHz Continuous Transmitting / 11Mbps / MAX-axis(Hor:Z VER:Z)

LIMIT : FCC15C §15.247(d) 3m, below 1GHz:QP, above 1GHz:AV  
Except for the data below : adequate margin data below the limits.

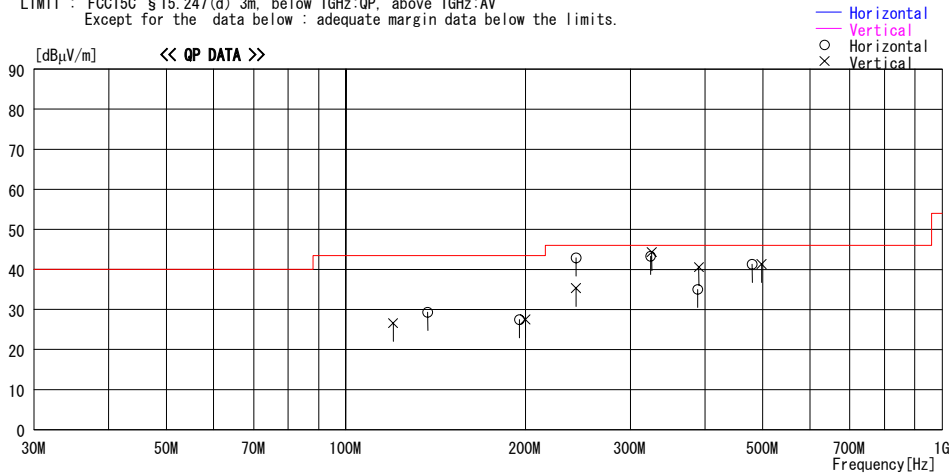

No.	FREQ [MHz]	READING QP [dBµV]	ANT FACTOR [dB/m]	LOSS [dB]	GAIN [dB]	RESULT [dBµV/m]	LIMIT [dBµV/m]	MARGIN [dB]	ANTENNA [cm]	TABLE [DEG]
----- Horizontal -----										
1	137.078	34.2	14.2	8.5	27.6	29.3	43.5	14.2	273	308
2	195.433	28.9	17.0	8.9	27.3	27.5	43.5	16.0	250	300
3	243.010	43.0	17.4	9.6	27.1	42.9	46.0	3.1	146	0
4	324.032	44.9	15.4	10.2	27.2	43.3	46.0	2.7	100	356
5	388.835	34.4	17.6	10.7	27.7	35.0	46.0	11.0	100	107
6	479.768	40.0	18.5	11.1	28.3	41.3	46.0	4.7	100	152
----- Vertical -----										
7	120.009	32.9	13.0	8.4	27.7	26.6	43.5	16.9	107	351
8	200.012	28.5	17.1	9.2	27.3	27.5	43.5	16.0	100	318
9	243.019	35.4	17.4	9.6	27.1	35.3	46.0	10.7	101	290
10	325.716	45.8	15.5	10.2	27.2	44.3	46.0	1.7	100	206
11	390.877	39.9	17.7	10.7	27.7	40.6	46.0	5.4	100	187
12	497.804	39.8	18.6	11.3	28.4	41.3	46.0	4.7	100	143

CHART: WITH FACTOR ANT TYPE : -30MHz LOOP, 30-300MHz BICONICAL, 300MHz-1000MHz LOGPERIODIC, 1000MHz- HORN  
CALCULATION : READING + ANT FACTOR + LOSS(CABLE+ATTEN.) - AMP. GAIN Page:

**Radiated Spurious Emission(DSSS and other forms of modulation) (below 1GHz)**

\* The result is rounded off to the second decimal place. Therefore, there may be 0.1 difference for the result.

**DATA OF RADIATED EMISSION TEST**

UL Apex Co., Ltd. Head Office EMC Lab. No.1 Semi Anechoic Chamber

Applicant : CANON INC. Report No. : 251E0087-HO  
Kind of EUT : WLAN module for printer Power : DC 3.35V  
Model No. : K30254 Temp°C/Humi% : 22deg. C / 52%  
Serial No. : 08F2E2 Operator : Norihisa Hashimoto

Mode / Remarks : IEEE802.11b 2437MHz Continuous Transmitting / 11Mbps / MAX-axis(Hor:Z VER:Z)

LIMIT : FCC15C §15.247(d) 3m, below 1GHz:QP, above 1GHz:AV  
Except for the data below : adequate margin data below the limits.

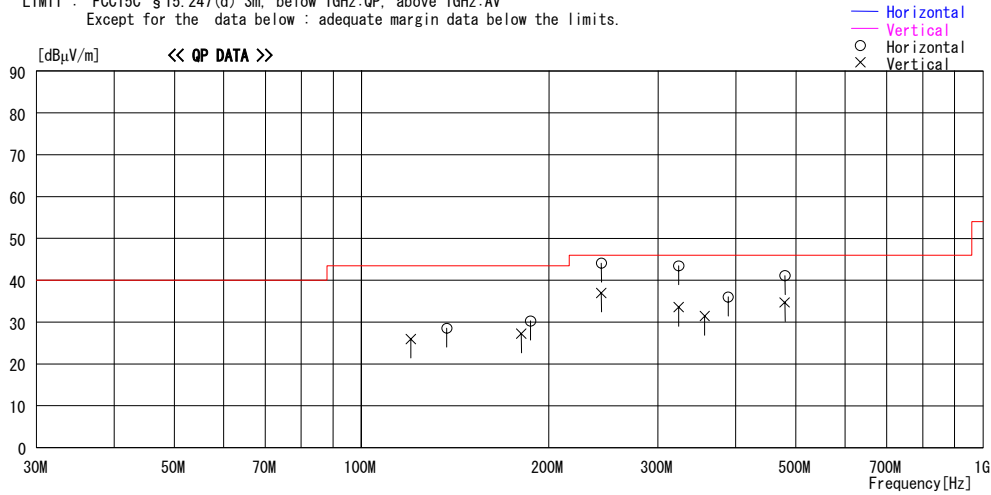

No.	FREQ [MHz]	READING QP [dBµV]	ANT FACTOR [dB/m]	LOSS [dB]	GAIN [dB]	RESULT [dBµV/m]	LIMIT [dBµV/m]	MARGIN [dB]	ANTENNA [cm]	TABLE [DEG]
----- Horizontal -----										
1	137.073	33.5	14.2	8.5	27.6	28.6	43.5	14.9	234	312
2	186.946	31.9	16.8	8.9	27.3	30.3	43.5	13.2	152	264
3	243.018	44.2	17.4	9.6	27.1	44.1	46.0	1.9	136	3
4	324.023	45.1	15.4	10.2	27.2	43.5	46.0	2.5	100	14
5	388.820	35.4	17.6	10.7	27.7	36.0	46.0	10.0	251	149
6	479.768	39.8	18.5	11.1	28.3	41.1	46.0	4.9	100	160
----- Vertical -----										
7	120.002	32.3	13.0	8.4	27.7	26.0	43.5	17.5	100	354
8	180.683	29.0	16.7	8.9	27.4	27.2	43.5	16.3	100	301
9	243.020	37.1	17.4	9.6	27.1	37.0	46.0	9.0	190	277
10	324.014	35.2	15.4	10.2	27.2	33.6	46.0	12.4	100	150
11	356.443	31.9	16.5	10.5	27.5	31.4	46.0	14.6	114	203
12	479.828	33.4	18.5	11.1	28.3	34.7	46.0	11.3	104	259

CHART:WITH FACTOR ANT TYPE : -30MHz LOOP, 30-300MHz BICONICAL, 300MHz-1000MHz LOGPERIODIC, 1000MHz- HORN  
CALCULATION : READING + ANT FACTOR + LOSS(CABLE+ATTEN.) - AMP. GAIN Page:



## Radiated Spurious Emission(DSSS and other forms of modulation) (below 1GHz)

\* The result is rounded off to the second decimal place. Therefore, there may be 0.1 difference for the result.

### DATA OF RADIATED EMISSION TEST

UL Apex Co., Ltd. Head Office EMC Lab. No.1 Semi Anechoic Chamber

Applicant : CANON INC.	Report No. : 25IE0087-HO
Kind of EUT : WLAN module for printer	Power : DC 3.35V
Model No. : K30254	Temp°C/Humi% : 22deg. C / 52%
Serial No. : 08F2E2	Operator : Norihisa Hashimoto

Mode / Remarks : IEEE802.11b 2462MHz Continuous Transmitting / 11Mbps / MAX-axis(Hor:Z VER:Z)

LIMIT : FCC15C §15.247(d) 3m. below 1GHz:QP. above 1GHz:AV  
Except for the data below : adequate margin data below the limits.

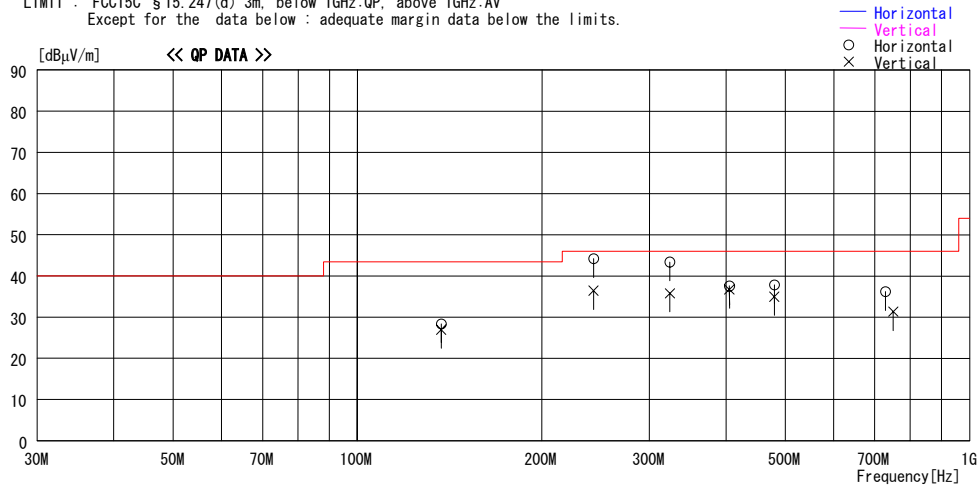

No.	FREQ [MHz]	READING QP [dBµV]	ANT FACTOR [dB/m]	LOSS [dB]	GAIN [dB]	RESULT [dBµV/m]	LIMIT [dBµV/m]	MARGIN [dB]	ANTENNA [cm]	TABLE [DEG]
----- Horizontal -----										
1	137.083	33.3	14.2	8.5	27.6	28.4	43.5	15.1	238	283
2	243.015	44.3	17.4	9.6	27.1	44.2	46.0	1.8	131	0
3	324.015	45.0	15.4	10.2	27.2	43.4	46.0	2.6	100	357
4	405.018	36.7	18.0	10.7	27.8	37.6	46.0	8.4	100	97
5	479.828	36.5	18.5	11.1	28.3	37.8	46.0	8.2	100	154
6	729.033	31.5	20.9	12.4	28.6	36.2	46.0	9.8	124	174
----- Vertical -----										
7	137.081	31.9	14.2	8.5	27.6	27.0	43.5	16.5	100	357
8	243.017	36.5	17.4	9.6	27.1	36.4	46.0	9.6	100	296
9	324.022	37.4	15.4	10.2	27.2	35.8	46.0	10.2	153	164
10	405.020	35.8	18.0	10.7	27.8	36.7	46.0	9.3	131	356
11	479.826	33.7	18.5	11.1	28.3	35.0	46.0	11.0	111	263
12	750.034	26.4	21.0	12.5	28.6	31.3	46.0	14.7	100	359

CHART: WITH FACTOR ANT TYPE : -30MHz LOOP, 30-300MHz BICONICAL, 300MHz-1000MHz LOGPERIODIC, 1000MHz- HORN  
CALCULATION : READING + ANT FACTOR + LOSS (CABLE+ATTEN.) - AMP. GAIN Page:

## Radiated Spurious Emission(DSSS and other forms of modulation) (below 1GHz)

\* The result is rounded off to the second decimal place. Therefore, there may be 0.1 difference for the result.

### DATA OF RADIATED EMISSION TEST

UL Apex Co., Ltd. Head Office EMC Lab. No.1 Semi Anechoic Chamber

Applicant : CANON INC.	Report No. : 251E0087-HO
Kind of EUT : WLAN module for printer	Power : DC 3.35V
Model No. : K30254	Temp°C/Humi% : 22deg. C / 52%
Serial No. : 08F2E2	Operator : Norihisa Hashimoto

Mode / Remarks : IEEE802.11g 2412MHz Continuous Transmitting / 54Mbps / MAX-axis(Hor:Z VER:Z)

LIMIT : FCC15C §15.247(d) 3m, below 1GHz:QP, above 1GHz:AV  
Except for the data below : adequate margin data below the limits.

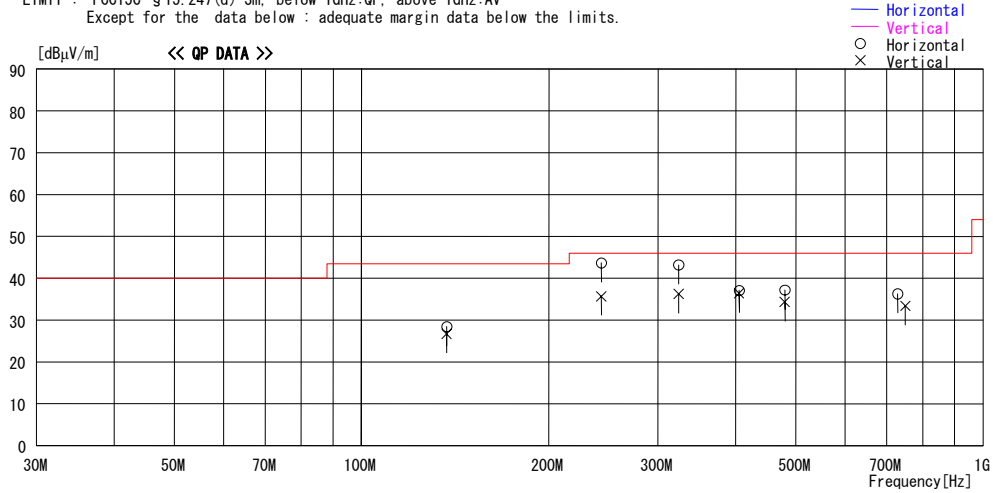

No.	FREQ [MHz]	READING QP [dBµV]	ANT FACTOR [dB/m]	LOSS [dB]	GAIN [dB]	RESULT [dBµV/m]	LIMIT [dBµV/m]	MARGIN [dB]	ANTENNA [cm]	TABLE [DEG]
----- Horizontal -----										
1	137.082	33.4	14.2	8.5	27.6	28.5	43.5	15.0	232	292
2	243.014	43.8	17.4	9.6	27.1	43.7	46.0	2.3	148	359
3	324.021	44.8	15.4	10.2	27.2	43.2	46.0	2.8	100	359
4	405.023	36.2	18.0	10.7	27.8	37.1	46.0	8.9	100	95
5	479.830	35.9	18.5	11.1	28.3	37.2	46.0	8.8	100	148
6	729.041	31.6	20.9	12.4	28.6	36.3	46.0	9.7	119	176
----- Vertical -----										
7	137.085	31.6	14.2	8.5	27.6	26.7	43.5	16.8	100	359
8	243.019	35.8	17.4	9.6	27.1	35.7	46.0	10.3	100	292
9	324.017	37.8	15.4	10.2	27.2	36.2	46.0	9.8	163	189
10	405.024	35.5	18.0	10.7	27.8	36.4	46.0	9.6	143	358
11	479.824	33.0	18.5	11.1	28.3	34.3	46.0	11.7	108	273
12	750.014	28.5	21.0	12.5	28.6	33.4	46.0	12.6	100	358

CHART: WITH FACTOR ANT TYPE : -30MHz- LOOP, 30-300MHz BICONICAL, 300MHz-1000MHz LOGPERIODIC, 1000MHz- HORN  
CALCULATION : READING + ANT FACTOR + LOSS(CABLE+ATTEN.) - AMP. GAIN Page:

**Radiated Spurious Emission(DSSS and other forms of modulation) (below 1GHz)**

\* The result is rounded off to the second decimal place. Therefore, there may be 0.1 difference for the result.

**DATA OF RADIATED EMISSION TEST**

UL Apex Co., Ltd. Head Office EMC Lab. No.1 Semi Anechoic Chamber

Applicant : CANON INC. Report No. : 25IE0087-HO  
Kind of EUT : WLAN module for printer Power : DC 3.35V  
Model No. : K30254 Temp/C/Humi% : 22deg. C / 52%  
Serial No. : 08F2E2 Operator : Norihisa Hashimoto

Mode / Remarks : IEEE802.11g 2437MHz Continuous Transmitting / 54Mbps / MAX-axis(Hor:Z VER:Z)

LIMIT : FCC15C §15.247(d) 3m, below 1GHz:QP, above 1GHz:AV  
Except for the data below : adequate margin data below the limits.

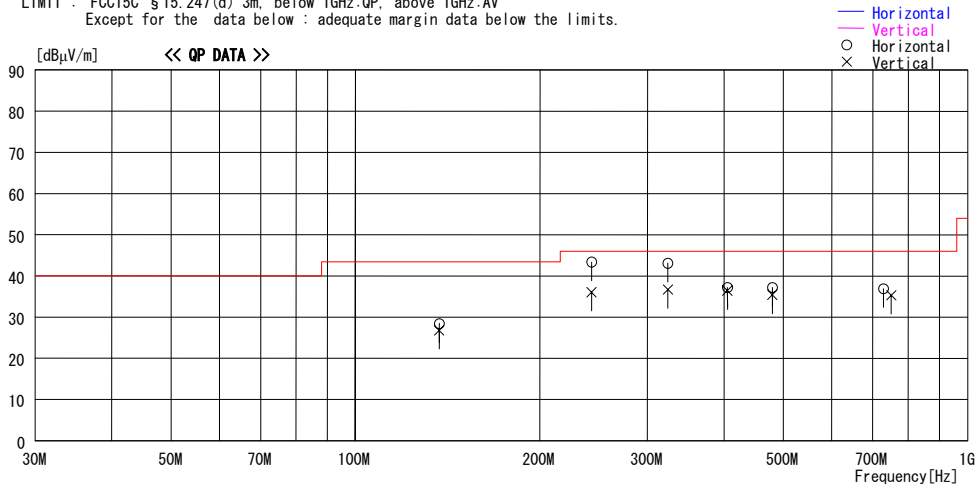

No.	FREQ [MHz]	READING QP [dBμV]	ANT FACTOR [dB/m]	LOSS	GAIN	RESULT	LIMIT	MARGIN	ANTENNA	TABLE
				[dB]	[dB]	[dBμV/m]	[dBμV/m]	[dB]	[cm]	[DEG]
----- Horizontal -----										
1	137.074	33.4	14.2	8.5	27.6	28.5	43.5	15.0	250	297
2	243.012	43.5	17.4	9.6	27.1	43.4	46.0	2.6	134	0
3	324.014	44.7	15.4	10.2	27.2	43.1	46.0	2.9	100	0
4	405.018	36.3	18.0	10.7	27.8	37.2	46.0	8.8	100	101
5	479.829	35.9	18.5	11.1	28.3	37.2	46.0	8.8	100	146
6	729.035	32.2	20.9	12.4	28.6	36.9	46.0	9.1	122	197
----- Vertical -----										
7	137.079	31.7	14.2	8.5	27.6	26.8	43.5	16.7	100	357
8	243.016	36.2	17.4	9.6	27.1	36.1	46.0	9.9	214	283
9	324.018	38.3	15.4	10.2	27.2	36.7	46.0	9.3	142	192
10	405.022	35.5	18.0	10.7	27.8	36.4	46.0	9.6	128	356
11	479.823	34.1	18.5	11.1	28.3	35.4	46.0	10.6	106	262
12	750.008	30.4	21.0	12.5	28.6	35.3	46.0	10.7	103	359

CHART: WITH FACTOR ANT TYPE : -30MHz LOOP, 30-300MHz BICONICAL, 300MHz-1000MHz LOGPERIODIC, 1000MHz- HORN  
CALCULATION : READING + ANT FACTOR + LOSS (CABLE+ATTEN.) - AMP. GAIN Page:

## Radiated Spurious Emission(DSSS and other forms of modulation) (below 1GHz)

\* The result is rounded off to the second decimal place. Therefore, there may be 0.1 difference for the result.

### DATA OF RADIATED EMISSION TEST

UL Apex Co., Ltd. Head Office EMC Lab. No.1 Semi Anechoic Chamber

Applicant : CANON INC.	Report No. : 25IE0087-H0
Kind of EUT : WLAN module for printer	Power : DC 3.35V
Model No. : K30254	Temp°C/Humi% : 22deg. C / 52%
Serial No. : 08F2E2	Operator : Norihisa Hashimoto

Mode / Remarks : IEEE802.11g 2462MHz Continuous Transmitting / 54Mbps / MAX-axis(Hor:Z VER:Z)

LIMIT : FCC15C §15.247(d) 3m. below 1GHz:QP. above 1GHz:AV  
Except for the data below : adequate margin data below the limits.

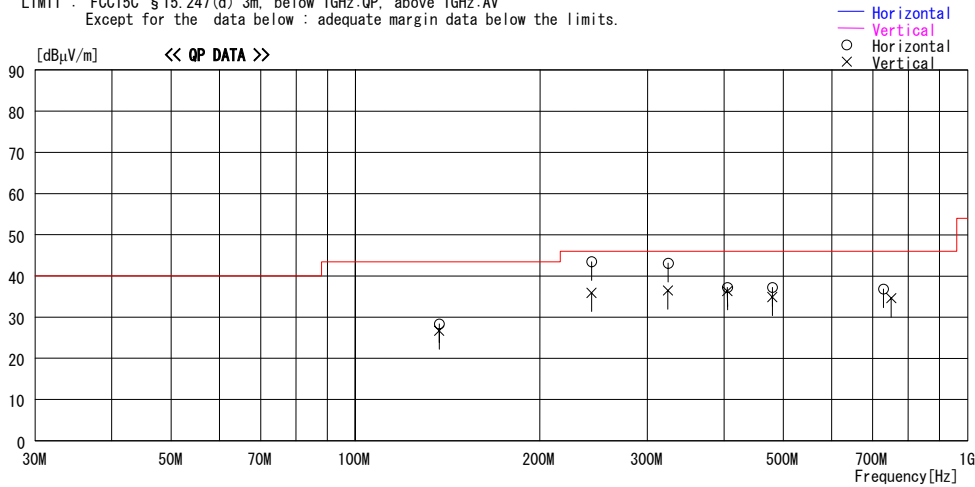

No.	FREQ [MHz]	READING QP [dBµV]	ANT FACTOR [dB/m]	LOSS	GAIN	RESULT	LIMIT	MARGIN	ANTENNA	TABLE
				[dB]	[dB]	[dBµV/m]	[dBµV/m]	[dB]	[cm]	[DEG]
----- Horizontal -----										
1	137.083	33.3	14.2	8.5	27.6	28.4	43.5	15.1	243	291
2	243.019	43.6	17.4	9.6	27.1	43.5	46.0	2.5	146	358
3	324.085	44.7	15.4	10.2	27.2	43.1	46.0	2.9	100	0
4	405.021	36.3	18.0	10.7	27.8	37.2	46.0	8.8	100	99
5	479.870	35.9	18.5	11.1	28.3	37.2	46.0	8.8	100	152
6	729.026	32.1	20.9	12.4	28.6	36.8	46.0	9.2	120	183
----- Vertical -----										
7	137.061	31.6	14.2	8.5	27.6	26.7	43.5	16.8	100	0
8	243.019	36.0	17.4	9.6	27.1	35.9	46.0	10.1	213	289
9	324.019	38.1	15.4	10.2	27.2	36.5	46.0	9.5	153	191
10	405.021	35.4	18.0	10.7	27.8	36.3	46.0	9.7	129	359
11	479.826	33.6	18.5	11.1	28.3	34.9	46.0	11.1	110	269
12	750.012	29.7	21.0	12.5	28.6	34.6	46.0	11.4	100	0

CHART: WITH FACTOR ANT TYPE : -30MHz LOOP, 30-300MHz BICONICAL, 300MHz-1000MHz LOGPERIODIC, 1000MHz- HORN  
CALCULATION : READING + ANT FACTOR + LOSS (CABLE+ATTEN.) - AMP. GAIN Page:

**Radiated Spurious Emission(DSSS and other forms of modulation) (above 1GHz)**

UL Apex Co., Ltd.  
Head Office EMC Lab. No.2 Semi Anechoic Chamber

Company	: CANON INC.	REPORT NO	: 25IE0087-HO
Equipment	: WLAN module for printer	REGULATION	: Fcc Part15 Subpart C 15.247(d)
Model	: K30254	TEST DISTANCE	: 3/1m
Sample No.	: 08F2E2	DATE	: 06/09/2005
Power	: DC 3.35V	TEMPERATURE	: 25.9deg.C
Mode	: 11b 11Mbps, Tx 2412MHz	HUMIDITY	: 49%
Remarks	: Hor Z-axis , Ver Z-axis	ENGINEER	: Norihisa Hashimoto

**PK DETECT (RBW: 1MHz, VBW: 1MHz)**

No.	FREQ [MHz]	S/A READING		ANT Factor [dB/m]	AMP GAIN [dB]	CABLE LOSS [dB]	Hi-Pass or ATT [dB]	RESULT		Limit PK [dBuV/m]	MARGIN	
		HOR [dBuV]	VER [dBuV]					HOR [dBuV/m]	VER [dBuV/m]		HOR [dB]	VER [dB]
<b>Test distance 3meters RESULT=Reading + ANT Factor - Amp Gain + Cable Loss + Filter Loss</b>												
1	2390.0	59.0	57.5	30.5	36.4	3.7	0.0	56.8	55.3	74.0	17.2	18.7
2*	2400.0	68.6	62.1	30.5	36.4	3.7	0.0	66.4	59.9	74.0	7.6	14.1
3	4824.2	43.0	42.6	35.2	36.0	5.3	1.0	48.5	48.1	74.0	25.5	25.9
4	7235.6	41.5	42.2	37.7	36.0	6.6	0.4	50.2	50.9	74.0	23.8	23.1
5	9648.6	43.3	42.9	37.0	36.4	7.9	0.2	52.0	51.6	74.0	22.0	22.4
<b>Test distance 1meters RESULT=Reading + ANT Factor - Amp Gain + Cable Loss + Filter Loss - Dfac</b>												
6	12060.0	45.3	45.0	41.6	36.1	14.3	0.0	55.6	55.3	74.0	18.4	18.7
7	14472.0	44.4	45.5	41.8	34.6	15.2	0.0	57.3	58.4	74.0	16.7	15.6
8	16884.0	45.6	45.6	45.2	35.0	16.6	0.0	62.9	62.9	74.0	11.1	11.1
9	19296.0	44.8	44.7	41.6	34.1	12.8	0.0	55.6	55.5	74.0	18.4	18.5
10	21708.0	45.5	44.4	40.4	34.7	13.0	0.0	54.7	53.6	74.0	19.3	20.4
11	24120.0	44.4	45.2	41.0	35.6	15.0	0.0	55.3	56.1	74.0	18.7	17.9

**AV DETECT (RBW: 1MHz, VBW: 10Hz)**

No.	FREQ [MHz]	S/A READING		ANT Factor [dB/m]	AMP GAIN [dB]	CABLE LOSS [dB]	Hi-Pass Filter [dB]	RESULT		Limit AV [dBuV/m]	MARGIN	
		HOR [dBuV]	VER [dBuV]					HOR [dBuV/m]	VER [dBuV/m]		HOR [dB]	VER [dB]
<b>Test distance 3meters RESULT=Reading + ANT Factor - Amp Gain + Cable Loss + Filter Loss</b>												
1	2390.0	32.7	36.1	30.5	36.4	3.7	0.0	30.5	33.9	54.0	23.5	20.1
2*	2400.0	57.8	51.5	30.5	36.4	3.7	0.0	55.6	49.3	54.0	-	-
3	4824.2	30.3	29.9	35.2	36.0	5.3	1.0	35.8	35.4	54.0	18.2	18.6
4	7235.6	29.5	29.5	37.7	36.0	6.6	0.4	38.2	38.2	54.0	15.8	15.8
5	9648.6	30.5	30.5	37.0	36.4	7.9	0.2	39.2	39.2	54.0	14.8	14.8
<b>Test distance 1meters RESULT=Reading + ANT Factor - Amp Gain + Cable Loss + Filter Loss - Dfac</b>												
6	12060.0	33.1	32.9	41.6	39.5	9.5	0.2	35.4	35.2	54.0	18.6	18.8
7	14472.0	32.7	32.6	41.8	41.2	9.7	0.1	33.6	33.5	54.0	20.4	20.5
8	16884.0	33.4	33.5	45.2	41.3	10.8	1.1	39.7	39.8	54.0	14.3	14.2
9	19296.0	31.7	31.7	40.2	39.9	12.0	0.0	34.5	34.5	54.0	19.5	19.5
10	21708.0	31.8	32.0	39.8	40.0	12.0	0.0	34.1	34.3	54.0	19.9	19.7
11	24120.0	32.0	32.0	40.4	38.3	13.9	0.0	38.5	38.5	54.0	15.5	15.5

\* Reference data

**20dBc(Fundamental 2402MHz) (RBW: 100kHz, VBW: 300kHz)**

No.	FREQ [MHz]	S/A READING		ANT Factor [dB/m]	AMP GAIN [dB]	CABLE LOSS [dB]	Hi-Pass Filter [dB]	RESULT		Limit 20dBc [dBuV/m]	MARGIN	
		HOR [dBuV]	VER [dBuV]					HOR [dBuV/m]	VER [dBuV/m]		HOR [dB]	VER [dB]
<b>Test distance 3meters RESULT=Reading + ANT Factor - Amp Gain + Cable Loss + Filter Loss</b>												
0	2413.3	97.3	98.0	30.5	36.4	3.7	0.0	95.1	95.8	-	-	-
2	2400.0	61.7	57.6	30.5	36.4	3.7	0.0	59.5	55.4	Funda-20dB	15.6	20.4

Test Distance 1.0m : Distance Factor(Dfac) = 20log(3/1.0) = 9.5dB

\*Except for the above table : All other spurious emissions were less than 20dB for the limit.

\*In the frequency over the fifth harmonic, the noise from the EUT was not seen. The data above is its base noise.

\*The result is rounded off to the second decimal place. Therefore, there may be 0.1 difference for the result.

\*Hi-Pass Filter was not used for factor 0.0dB of the above table.

**Radiated Spurious Emission(DSSS and other forms of modulation) (above 1GHz)**

UL Apex Co., Ltd.  
Head Office EMC Lab. No.2 Semi Anechoic Chamber

Company	: CANON INC.	REPORT NO	: 25IE0087-HO
Equipment	: WLAN module for printer	REGULATION	: Fcc Part15 Subpart C 15.247(d)
Model	: K30254	TEST DISTANCE	: 3/1m
Sample No.	: 08F2E2	DATE	: 06/09/2005
Power	: DC 3.35V	TEMPERATURE	: 25.9deg.C
Mode	: 11b 11Mbps, Tx 2437MHz	HUMIDITY	: 49%
Remarks	: Hor Z-axis , Ver Z-axis	ENGINEER	: Norihisa Hashimoto

**PK DETECT** (RBW: 1MHz, VBW: 1MHz)

No.	FREQ [MHz]	S/A READING		ANT Factor [dB/m]	AMP GAIN [dB]	CABLE LOSS [dB]	Hi-Pass or ATT [dB]	RESULT		Limit PK [dBuV/m]	MARGIN	
		HOR	VER					HOR	VER		HOR	VER
<b>Test distance 3meters RESULT=Reading + ANT Factor - Amp Gain + Cable Loss + Filter Loss</b>												
1	4874.5	42.0	42.2	35.5	36.0	5.3	1.0	47.8	48.0	74.0	26.2	26.0
2	7311.1	42.7	42.2	37.9	36.0	6.6	0.5	51.7	51.2	74.0	22.3	22.8
3	9747.4	42.8	42.3	36.9	36.4	8.1	0.2	51.6	51.1	74.0	22.4	22.9
<b>Test distance 1meters RESULT=Reading + ANT Factor - Amp Gain + Cable Loss + Filter Loss - Dfac</b>												
4	12185.0	45.4	45.0	41.6	39.6	9.5	0.3	47.7	47.3	74.0	26.3	26.7
5	14622.0	45.8	45.6	42.1	41.1	9.8	0.2	47.3	47.1	74.0	26.7	26.9
6	17059.0	45.8	46.5	45.3	41.3	10.8	1.1	52.2	52.9	74.0	21.8	21.1
7	19496.0	45.0	44.0	40.3	39.8	12.1	0.0	48.1	47.1	74.0	25.9	26.9
8	21933.0	45.3	45.4	39.8	40.1	12.0	0.0	47.5	47.6	74.0	26.5	26.4
9	24370.0	43.7	45.1	40.4	38.5	14.0	0.0	50.1	51.5	74.0	23.9	22.5

**AV DETECT** (RBW: 1MHz, VBW: 10Hz)

No.	FREQ [MHz]	S/A READING		ANT Factor [dB/m]	AMP GAIN [dB]	CABLE LOSS [dB]	Hi-Pass Filter [dB]	RESULT		Limit AV [dBuV/m]	MARGIN	
		HOR	VER					HOR	VER		HOR	VER
<b>Test distance 3meters RESULT=Reading + ANT Factor - Amp Gain + Cable Loss + Filter Loss</b>												
1	4874.5	29.8	29.8	35.5	36.0	5.3	1.0	35.6	35.6	54.0	18.4	18.4
2	7311.1	29.7	29.6	37.9	36.0	6.6	0.5	38.7	38.6	54.0	15.3	15.4
3	9747.4	30.3	30.3	36.9	36.4	8.1	0.2	39.1	39.1	54.0	14.9	14.9
<b>Test distance 1meters RESULT=Reading + ANT Factor - Amp Gain + Cable Loss + Filter Loss - Dfac</b>												
4	12185.0	32.7	33.0	41.6	39.6	9.5	0.3	35.0	35.3	54.0	19.0	18.7
5	14622.0	33.2	33.4	42.1	41.1	9.8	0.2	34.7	34.9	54.0	19.3	19.1
6	17059.0	34.0	34.0	45.3	41.3	10.8	1.1	40.4	40.4	54.0	13.6	13.6
7	19496.0	32.4	31.8	40.3	39.8	12.1	0.0	35.5	34.9	54.0	18.5	19.1
8	21933.0	32.5	32.2	39.8	40.1	12.0	0.0	34.7	34.4	54.0	19.3	19.6
9	24370.0	31.4	31.1	40.4	38.5	14.0	0.0	37.8	37.5	54.0	16.2	16.5

Test Distance 1.0m ; Distance Factor(Dfac) = 20log(3/1.0) = 9.5dB  
\*Except for the above table : All other spurious emissions were less than 20dB for the limit.  
\*In the frequency over the fifth harmonic, the noise from the EUT was not seen.The data above is its base noise.  
\*The result is rounded off to the second decimal place. Therefore, there may be 0.1 difference for the result.  
\*Hi-Pass Fiter was not used for factor 0.0dB of the above table.

**Radiated Spurious Emission(DSSS and other forms of modulation) (above 1GHz)**

UL Apex Co., Ltd.  
Head Office EMC Lab. No.2 Semi Anechoic Chamber

Company	: CANON INC.	REPORT NO	: 25IE0087-HO
Equipment	: WLAN module for printer	REGULATION	: Fcc Part15 Subpart C 15.247(d)
Model	: K30254	TEST DISTANCE	: 3/1m
Sample No.	: 08F2E2	DATE	: 06/09/2005
Power	: DC 3.35V	TEMPERATURE	: 25.9deg.C
Mode	: 11b 11Mbps, Tx 2462MHz	HUMIDITY	: 49%
Remarks	: Hor Z-axis , Ver Z-axis	ENGINEER	: Norihisa Hashimoto

**PK DETECT (RBW: 1MHz, VBW: 1MHz)**

No.	FREQ [MHz]	S/A READING		ANT Factor [dB/m]	AMP GAIN [dB]	CABLE LOSS [dB]	Hi-Pass or ATT [dB]	RESULT		Limit PK [dBuV/m]	MARGIN	
		HOR [dBuV]	VER					HOR	VER		HOR	VER
<b>Test distance 3meters RESULT=Reading + ANT Factor - Amp Gain + Cable Loss + Filter Loss</b>												
1	2483.5	55.2	56.0	30.5	36.4	3.7	0.0	53.0	53.8	74.0	21.0	20.2
2	4923.2	42.2	43.4	35.8	35.9	5.3	1.0	48.4	49.6	74.0	25.6	24.4
3	7383.6	43.1	41.3	38.0	36.0	6.6	0.6	52.3	50.5	74.0	21.7	23.5
4	9348.5	41.2	42.9	37.0	36.3	7.9	0.1	49.9	51.6	74.0	24.1	22.4
<b>Test distance 1meters RESULT=Reading + ANT Factor - Amp Gain + Cable Loss + Filter Loss - Dfac</b>												
5	12310.0	44.9	45.8	41.7	39.8	9.5	0.4	47.2	48.1	74.0	26.8	25.9
6	14772.0	45.4	44.6	42.4	41.1	9.9	0.4	47.5	46.7	74.0	26.5	27.3
7	17234.0	46.4	46.0	44.9	41.3	10.9	1.0	52.4	52.0	74.0	21.6	22.0
8	19696.0	43.7	44.9	40.3	39.6	12.2	0.0	47.1	48.3	74.0	26.9	25.7
9	22158.0	45.0	45.6	39.8	39.9	12.1	0.0	47.5	48.1	74.0	26.5	25.9
10	24620.0	44.0	44.0	40.5	38.8	14.0	0.0	50.2	50.2	74.0	23.8	23.8

**AV DETECT (RBW: 1MHz, VBW: 10Hz)**

No.	FREQ [MHz]	S/A READING		ANT Factor [dB/m]	AMP GAIN [dB]	CABLE LOSS [dB]	Hi-Pass Filter [dB]	RESULT		Limit AV [dBuV/m]	MARGIN	
		HOR [dBuV]	VER					HOR	VER		HOR	VER
<b>Test distance 3meters RESULT=Reading + ANT Factor - Amp Gain + Cable Loss + Filter Loss</b>												
1	2483.5	42.4	42.7	30.5	36.4	3.7	0.0	40.2	40.5	54.0	13.8	13.5
2	4923.2	29.5	30.0	35.8	35.9	5.3	1.0	35.7	36.2	54.0	18.3	17.8
3	7383.6	29.6	29.5	38.0	36.0	6.6	0.6	38.8	38.7	54.0	15.2	15.3
4	9348.5	30.1	30.1	37.0	36.3	7.9	0.1	38.8	38.8	54.0	15.2	15.2
<b>Test distance 1meters RESULT=Reading + ANT Factor - Amp Gain + Cable Loss + Filter Loss - Dfac</b>												
5	12310.0	33.2	33.3	41.7	39.8	9.5	0.4	35.5	35.6	54.0	18.5	18.4
6	14772.0	32.5	32.5	42.4	41.1	9.9	0.4	34.6	34.6	54.0	19.4	19.4
7	17234.0	33.9	33.9	44.9	41.3	10.9	1.0	39.9	39.9	54.0	14.1	14.1
8	19696.0	32.0	32.4	40.3	39.6	12.2	0.0	35.4	35.8	54.0	18.6	18.2
9	22158.0	32.6	32.8	39.8	39.9	12.1	0.0	35.1	35.3	54.0	18.9	18.7
10	24620.0	31.0	31.1	40.5	38.8	14.0	0.0	37.2	37.3	54.0	16.8	16.7

Test Distance 1.0m : Distance Factor(Dfac) = 20log(3/1.0) = 9.5dB  
\*Except for the above table : All other spurious emissions were less than 20dB for the limit.  
\*In the frequency over the fifth harmonic, the noise from the EUT was not seen.The data above is its base noise.  
\*The result is rounded off to the second decimal place. Therefore, there may be 0.1 difference for the result.  
\*Hi-Pass Fiter was not used for factor 0.0dB of the above table.

**Radiated Spurious Emission(DSSS and other forms of modulation) (above 1GHz)**

UL Apex Co., Ltd.  
Head Office EMC Lab. No.2 Semi Anechoic Chamber

Company	: CANON INC.	REPORT NO	: 25IE0087-HO
Equipment	: WLAN module for printer	REGULATION	: Fcc Part15 Subpart C 15.247(d)
Model	: K30254	TEST DISTANCE	: 3/1m
Sample No.	: 08F2E2	DATE	: 06/09/2005
Power	: DC 3.35V	TEMPERATURE	: 25.9deg.C
Mode	: 11g 54Mbps, Tx 2412MHz	HUMIDITY	: 49%
Remarks	: Hor Z-axis, Ver Z-axis	ENGINEER	: Norihisa Hashimoto

**PK DETECT (RBW: 1MHz, VBW: 1MHz)**

No.	FREQ [MHz]	S/A READING		ANT Factor [dB/m]	AMP GAIN [dB]	CABLE LOSS [dB]	Hi-Pass or ATT [dB]	RESULT		Limit PK [dBuV/m]	MARGIN	
		HOR [dBuV]	VER [dBuV]					HOR [dBuV/m]	VER [dBuV/m]		HOR [dB]	VER [dB]
<b>Test distance 3meters RESULT=Reading + ANT Factor - Amp Gain + Cable Loss + Filter Loss</b>												
1	2390.0	54.8	68.4	30.5	36.4	3.7	0.0	52.6	66.2	74.0	21.4	7.8
2*	2400.0	81.4	81.5	30.5	36.4	3.7	0.0	79.2	79.3	74.0	-	-
3	4824.1	42.8	41.8	35.2	36.0	5.3	1.0	48.3	47.3	74.0	25.7	26.7
4	7236.0	42.1	42.2	37.7	36.0	6.6	0.4	50.8	50.9	74.0	23.2	23.1
5	9648.1	42.8	42.7	37.0	36.4	7.9	0.2	51.5	51.4	74.0	22.5	22.6
<b>Test distance 1meters RESULT=Reading + ANT Factor - Amp Gain + Cable Loss + Filter Loss - Dfac</b>												
6	12060.0	45.3	46.0	41.6	39.5	9.5	0.2	47.6	48.3	74.0	26.4	25.7
7	14472.0	45.1	46.1	41.8	41.2	9.7	0.1	46.0	47.0	74.0	28.0	27.0
8	16884.0	45.1	45.6	45.2	41.3	10.8	1.1	51.4	51.9	74.0	22.6	22.1
9	19296.0	43.8	48.7	40.2	39.9	12.0	0.0	46.6	51.5	74.0	27.4	22.5
10	21708.0	45.4	45.4	39.8	40.0	12.0	0.0	47.7	47.7	74.0	26.3	26.3
11	24120.0	47.7	45.9	40.4	38.3	13.9	0.0	54.2	52.4	74.0	19.8	21.6

**AV DETECT (RBW: 1MHz, VBW: 10Hz)**

No.	FREQ [MHz]	S/A READING		ANT Factor [dB/m]	AMP GAIN [dB]	CABLE LOSS [dB]	Hi-Pass Filter [dB]	RESULT		Limit AV [dBuV/m]	MARGIN	
		HOR [dBuV]	VER [dBuV]					HOR [dBuV/m]	VER [dBuV/m]		HOR [dB]	VER [dB]
<b>Test distance 3meters RESULT=Reading + ANT Factor - Amp Gain + Cable Loss + Filter Loss</b>												
1	2390.0	42.0	52.5	30.5	36.4	3.7	0.0	39.8	50.3	54.0	14.2	3.7
2*	2400.0	66.6	65.9	30.5	36.4	3.7	0.0	64.4	63.7	54.0	-	-
3	4824.1	30.0	29.9	35.2	36.0	5.3	1.0	35.5	35.4	54.0	18.5	18.6
4	7236.0	29.8	29.9	37.7	36.0	6.6	0.4	38.5	38.6	54.0	15.5	15.4
5	9648.1	31.0	30.7	37.0	36.4	7.9	0.2	39.7	39.4	54.0	14.3	14.6
<b>Test distance 1meters RESULT=Reading + ANT Factor - Amp Gain + Cable Loss + Filter Loss - Dfac</b>												
6	12060.0	33.7	33.5	41.6	39.5	9.5	0.2	36.0	35.8	54.0	18.0	18.2
7	14472.0	33.3	33.3	41.8	41.2	9.7	0.1	34.2	34.2	54.0	19.8	19.8
8	16884.0	33.7	33.4	45.2	41.3	10.8	1.1	40.0	39.7	54.0	14.0	14.3
9	19296.0	31.8	35.6	40.2	39.9	12.0	0.0	34.6	38.4	54.0	19.4	15.6
10	21708.0	32.2	32.3	39.8	40.0	12.0	0.0	34.5	34.6	54.0	19.5	19.4
11	24120.0	36.2	32.3	40.4	38.3	13.9	0.0	42.7	38.8	54.0	11.3	15.2

\* Reference data

**20dBc(Fundamental 2402MHz) (RBW: 100kHz, VBW: 300kHz)**

No.	FREQ [MHz]	S/A READING		ANT Factor [dB/m]	AMP GAIN [dB]	CABLE LOSS [dB]	Hi-Pass Filter [dB]	RESULT		Limit 20dBc [dBuV/m]	MARGIN	
		HOR [dBuV]	VER [dBuV]					HOR [dBuV/m]	VER [dBuV/m]		HOR [dB]	VER [dB]
<b>Test distance 3meters RESULT=Reading + ANT Factor - Amp Gain + Cable Loss + Filter Loss</b>												
0	2413.8	99.1	97.1	30.5	36.4	3.7	0.0	96.9	94.9	-	-	-
2	2400.0	66.4	66.0	30.5	36.4	3.7	0.0	64.2	63.8	Funda-20dB	12.7	11.1

Test Distance 1.0m : Distance Factor(Dfac) = 20log(3/1.0) = 9.5dB

\*Except for the above table : All other spurious emissions were less than 20dB for the limit.

\*In the frequency over the fifth harmonic, the noise from the EUT was not seen. The data above is its base noise.

\*The result is rounded off to the second decimal place. Therefore, there may be 0.1 difference for the result.

\*Hi-Pass Filter was not used for factor 0.0dB of the above table.



**Radiated Spurious Emission(DSSS and other forms of modulation) (above 1GHz)**

UL Apex Co., Ltd.  
Head Office EMC Lab. No.2 Semi Anechoic Chamber

Company	: CANON INC.	REPORT NO	: 25IE0087-HO
Equipment	: WLAN module for printer	REGULATION	: Fcc Part15 Subpart C 15.247(d)
Model	: K30254	TEST DISTANCE	: 3/1m
Sample No.	: 08F2E2	DATE	: 06/09/2005
Power	: DC 3.35V	TEMPERATURE	: 25.9deg.C
Mode	: 11g 54Mbps, Tx 2437MHz	HUMIDITY	: 49%
Remarks	: Hor Z-axis , Ver Z-axis	ENGINEER	: Norihisa Hashimoto

**PK DETECT (RBW: 1MHz, VBW: 1MHz)**

No.	FREQ [MHz]	S/A READING		ANT Factor [dB/m]	AMP GAIN [dB]	CABLE LOSS [dB]	Hi-Pass or ATT [dB]	RESULT		Limit PK [dBuV/m]	MARGIN	
		HOR	VER					HOR	VER		HOR	VER
<b>Test distance 3meters RESULT=Reading + ANT Factor - Amp Gain + Cable Loss + Filter Loss</b>												
1	4873.0	42.3	42.6	35.5	36.0	5.3	1.0	48.1	48.4	74.0	25.9	25.6
2	7320.0	42.6	41.2	37.9	36.0	6.6	0.5	51.6	50.2	74.0	22.4	23.8
3	9718.1	42.9	41.3	36.9	36.4	8.1	0.2	51.7	50.1	74.0	22.3	23.9
<b>Test distance 1meters RESULT=Reading + ANT Factor - Amp Gain + Cable Loss + Filter Loss - Dfac</b>												
4	12185.0	46.0	45.4	41.6	39.6	9.5	0.3	48.3	47.7	74.0	25.7	26.3
5	14622.0	44.8	44.9	42.1	41.1	9.8	0.2	46.3	46.4	74.0	27.7	27.6
6	17059.0	44.7	46.9	45.3	41.3	10.8	1.1	51.1	53.3	74.0	22.9	20.7
7	19496.0	45.0	45.9	40.3	39.8	12.1	0.0	48.1	49.0	74.0	25.9	25.0
8	21933.0	45.9	44.6	39.8	40.1	12.0	0.0	48.1	46.8	74.0	25.9	27.2
9	24370.0	44.7	43.7	40.4	38.5	14.0	0.0	51.1	50.1	74.0	22.9	23.9

**AV DETECT (RBW: 1MHz, VBW: 10Hz)**

No.	FREQ [MHz]	S/A READING		ANT Factor [dB/m]	AMP GAIN [dB]	CABLE LOSS [dB]	Hi-Pass Filter [dB]	RESULT		Limit AV [dBuV/m]	MARGIN	
		HOR	VER					HOR	VER		HOR	VER
<b>Test distance 3meters RESULT=Reading + ANT Factor - Amp Gain + Cable Loss + Filter Loss</b>												
1	4873.0	29.7	30.3	35.5	36.0	5.3	1.0	35.5	36.1	54.0	18.5	17.9
2	7320.0	29.7	29.9	37.9	36.0	6.6	0.5	38.7	38.9	54.0	15.3	15.1
3	9718.1	30.2	30.5	36.9	36.4	8.1	0.2	39.0	39.3	54.0	15.0	14.7
<b>Test distance 1meters RESULT=Reading + ANT Factor - Amp Gain + Cable Loss + Filter Loss - Dfac</b>												
4	12185.0	33.2	33.4	41.6	39.6	9.5	0.3	35.5	35.7	54.0	18.5	18.3
5	14622.0	32.4	32.8	42.1	41.1	9.8	0.2	33.9	34.3	54.0	20.1	19.7
6	17059.0	34.1	34.1	45.3	41.3	10.8	1.1	40.5	40.5	54.0	13.5	13.5
7	19496.0	32.5	31.9	40.3	39.8	12.1	0.0	35.6	35.0	54.0	18.4	19.0
8	21933.0	32.6	32.5	39.8	40.1	12.0	0.0	34.8	34.7	54.0	19.2	19.3
9	24370.0	31.7	31.2	40.4	38.5	14.0	0.0	38.1	37.6	54.0	15.9	16.4

Test Distance 1.0m : Distance Factor(Dfac) = 20log(3/1.0) = 9.5dB  
\*Except for the above table : All other spurious emissions were less than 20dB for the limit.  
\*In the frequency over the fifth harmonic, the noise from the EUT was not seen.The data above is its base noise.  
\*The result is rounded off to the second decimal place. Therefore, there may be 0.1 difference for the result.  
\*Hi-Pass Fiter was not used for factor 0.0dB of the above table.

**Radiated Spurious Emission(DSSS and other forms of modulation) (above 1GHz)**

UL Apex Co., Ltd.  
Head Office EMC Lab. No.2 Semi Anechoic Chamber

Company	: CANON INC.	REPORT NO	: 25IE0087-HO
Equipment	: WLAN module for printer	REGULATION	: Fcc Part15 Subpart C 15.247(d)
Model	: K30254	TEST DISTANCE	: 3/1m
Sample No.	: 08F2E2	DATE	: 06/09/2005
Power	: DC 3.35V	TEMPERATURE	: 25.9deg.C
Mode	: 11g 54Mbps, Tx 2462MHz	HUMIDITY	: 49%
Remarks	: Hor Z-axis , Ver Z-axis	ENGINEER	: Norihisa Hashimoto

**PK DETECT (RBW: 1MHz, VBW: 1MHz)**

No.	FREQ [MHz]	S/A READING		ANT Factor [dB/m]	AMP GAIN [dB]	CABLE LOSS [dB]	Hi-Pass or ATT [dB]	RESULT		Limit PK [dBuV/m]	MARGIN	
		HOR [dBuV]	VER					HOR	VER		HOR	VER
<b>Test distance 3meters RESULT=Reading + ANT Factor - Amp Gain + Cable Loss + Filter Loss</b>												
1	2483.5	62.9	65.6	30.5	36.4	3.7	0.0	60.7	63.4	74.0	13.3	10.6
2	4924.0	41.5	40.9	35.8	35.9	5.3	1.0	47.7	47.1	74.0	26.3	26.9
3	7386.0	41.2	40.7	38.0	36.0	6.6	0.6	50.4	49.9	74.0	23.6	24.1
4	9348.0	42.2	41.3	37.0	36.3	7.9	0.1	50.9	50.0	74.0	23.1	24.0
<b>Test distance 1meters RESULT=Reading + ANT Factor - Amp Gain + Cable Loss + Filter Loss - Dfac</b>												
5	12310.0	45.7	46.0	41.7	39.8	9.5	0.4	48.0	48.3	74.0	26.0	25.7
6	14772.0	44.7	45.0	42.4	41.1	9.9	0.4	46.8	47.1	74.0	27.2	26.9
7	17234.0	46.0	46.3	44.9	41.3	10.9	1.0	52.0	52.3	74.0	22.0	21.7
8	19696.0	44.7	45.8	40.3	39.6	12.2	0.0	48.1	49.2	74.0	25.9	24.8
9	22158.0	46.0	45.2	39.8	39.9	12.1	0.0	48.5	47.7	74.0	25.5	26.3
10	24620.0	43.7	44.2	40.5	38.8	14.0	0.0	49.9	50.4	74.0	24.1	23.6

**AV DETECT (RBW: 1MHz, VBW: 10Hz)**

No.	FREQ [MHz]	S/A READING		ANT Factor [dB/m]	AMP GAIN [dB]	CABLE LOSS [dB]	Hi-Pass Filter [dB]	RESULT		Limit AV [dBuV/m]	MARGIN	
		HOR [dBuV]	VER					HOR	VER		HOR	VER
<b>Test distance 3meters RESULT=Reading + ANT Factor - Amp Gain + Cable Loss + Filter Loss</b>												
1	2483.5	44.6	48.5	30.5	36.4	3.7	0.0	42.4	46.3	54.0	11.6	7.7
2	4924.0	29.5	29.5	35.8	35.9	5.3	1.0	35.7	35.7	54.0	18.3	18.3
3	7386.0	29.6	30.0	38.0	36.0	6.6	0.6	38.8	39.2	54.0	15.2	14.8
4	9348.0	30.6	30.3	37.0	36.3	7.9	0.1	39.3	39.0	54.0	14.7	15.0
<b>Test distance 1meters RESULT=Reading + ANT Factor - Amp Gain + Cable Loss + Filter Loss - Dfac</b>												
5	12310.0	33.0	33.4	41.7	39.8	9.5	0.4	35.3	35.7	54.0	18.7	18.3
6	14772.0	32.3	32.3	42.4	41.1	9.9	0.4	34.4	34.4	54.0	19.6	19.6
7	17234.0	33.6	33.6	44.9	41.3	10.9	1.0	39.6	39.6	54.0	14.4	14.4
8	19696.0	31.8	32.2	40.3	39.6	12.2	0.0	35.2	35.6	54.0	18.8	18.4
9	22158.0	32.6	32.5	39.8	39.9	12.1	0.0	35.1	35.0	54.0	18.9	19.0
10	24620.0	31.0	31.2	40.5	38.8	14.0	0.0	37.2	37.4	54.0	16.8	16.6

Test Distance 1.0m : Distance Factor(Dfac) = 20log(3/1.0) = 9.5dB  
\*Except for the above table : All other spurious emissions were less than 20dB for the limit.  
\*In the frequency over the fifth harmonic, the noise from the EUT was not seen.The data above is its base noise.  
\*The result is rounded off to the second decimal place. Therefore, there may be 0.1 difference for the result.  
\*Hi-Pass Fiter was not used for factor 0.0dB of the above table.

**Conducted Spurious Emission(DSSS and other forms of modulation)**  
**11b, 11Mbps, Ch : Low**

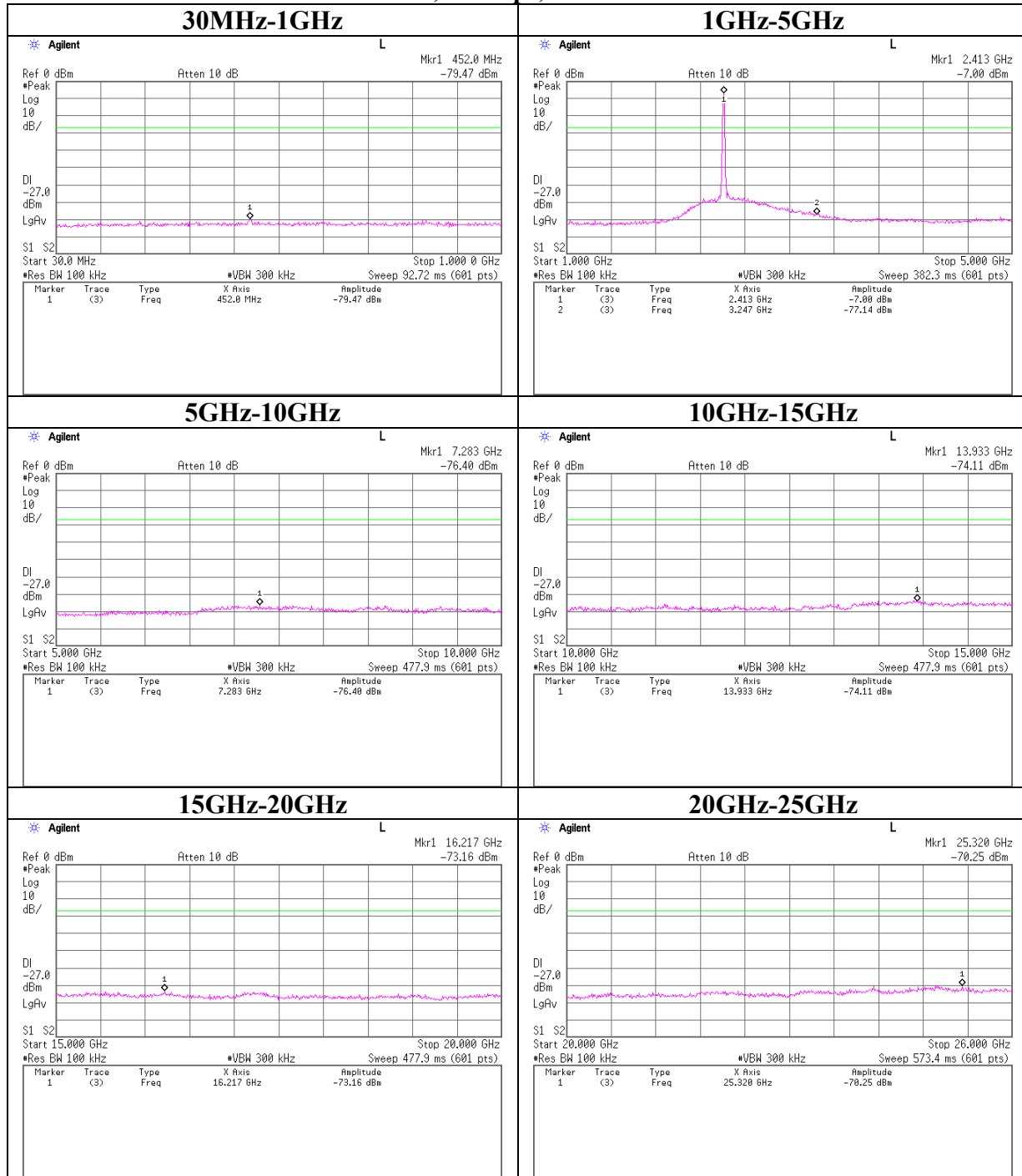

**Conducted Spurious Emission(DSSS and other forms of modulation)**  
**11b, 11Mbps, Ch : Mid**

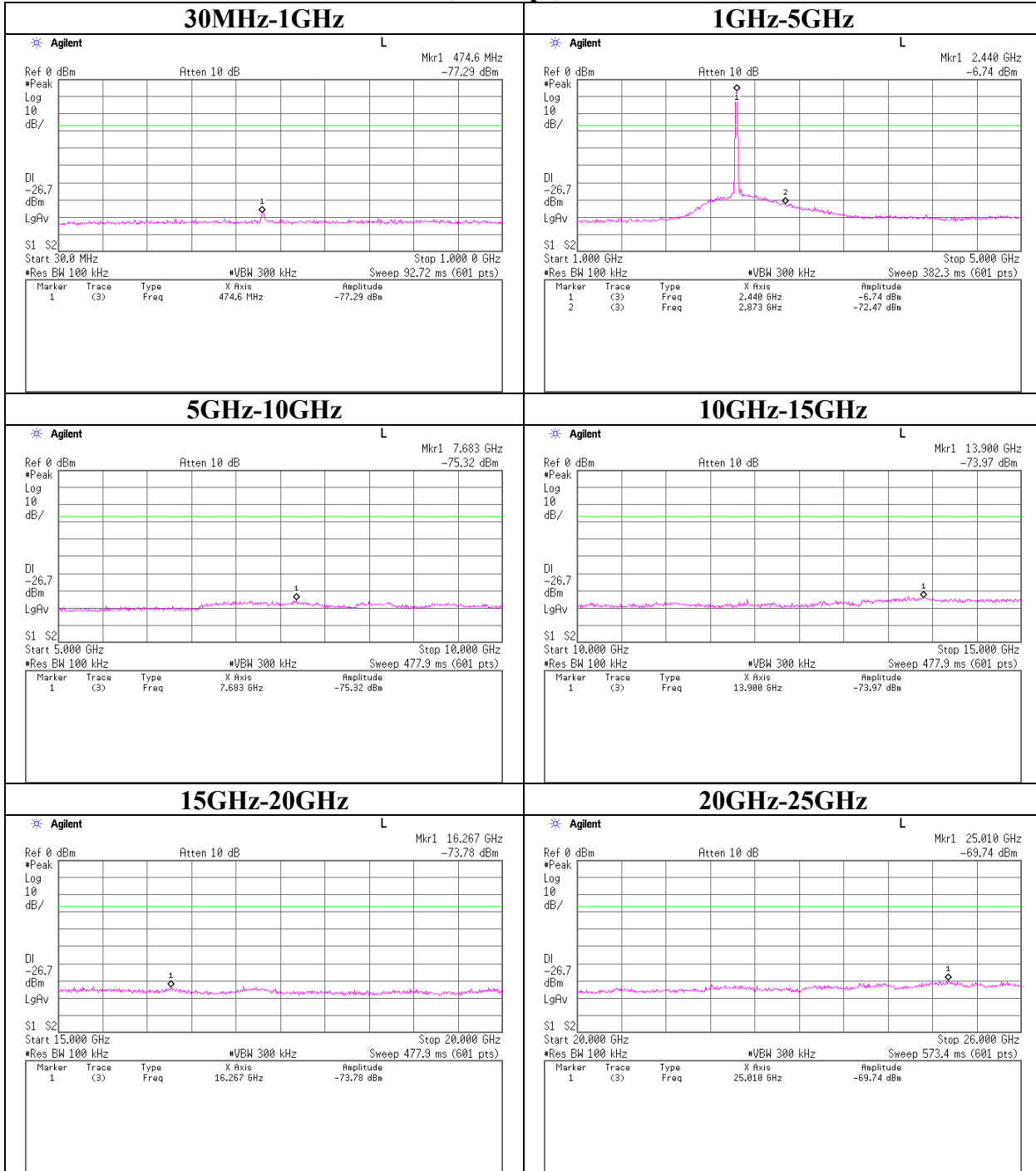

**Conducted Spurious Emission(DSSS and other forms of modulation)**  
**11b, 11Mbps, Ch : High**

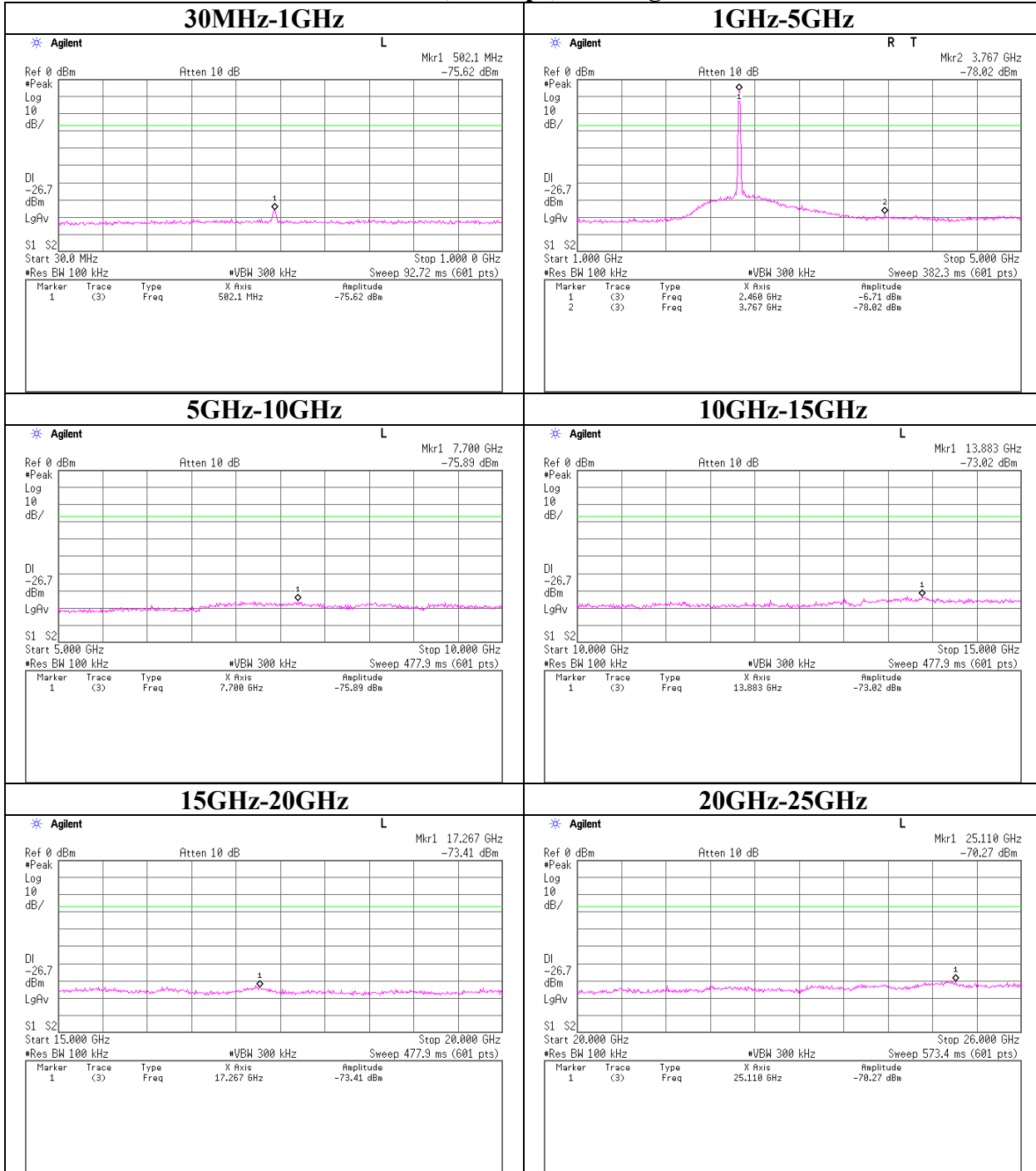

**Conducted Spurious Emission(DSSS and other forms of modulation)**  
**11g, 54Mbps, Ch : Low**

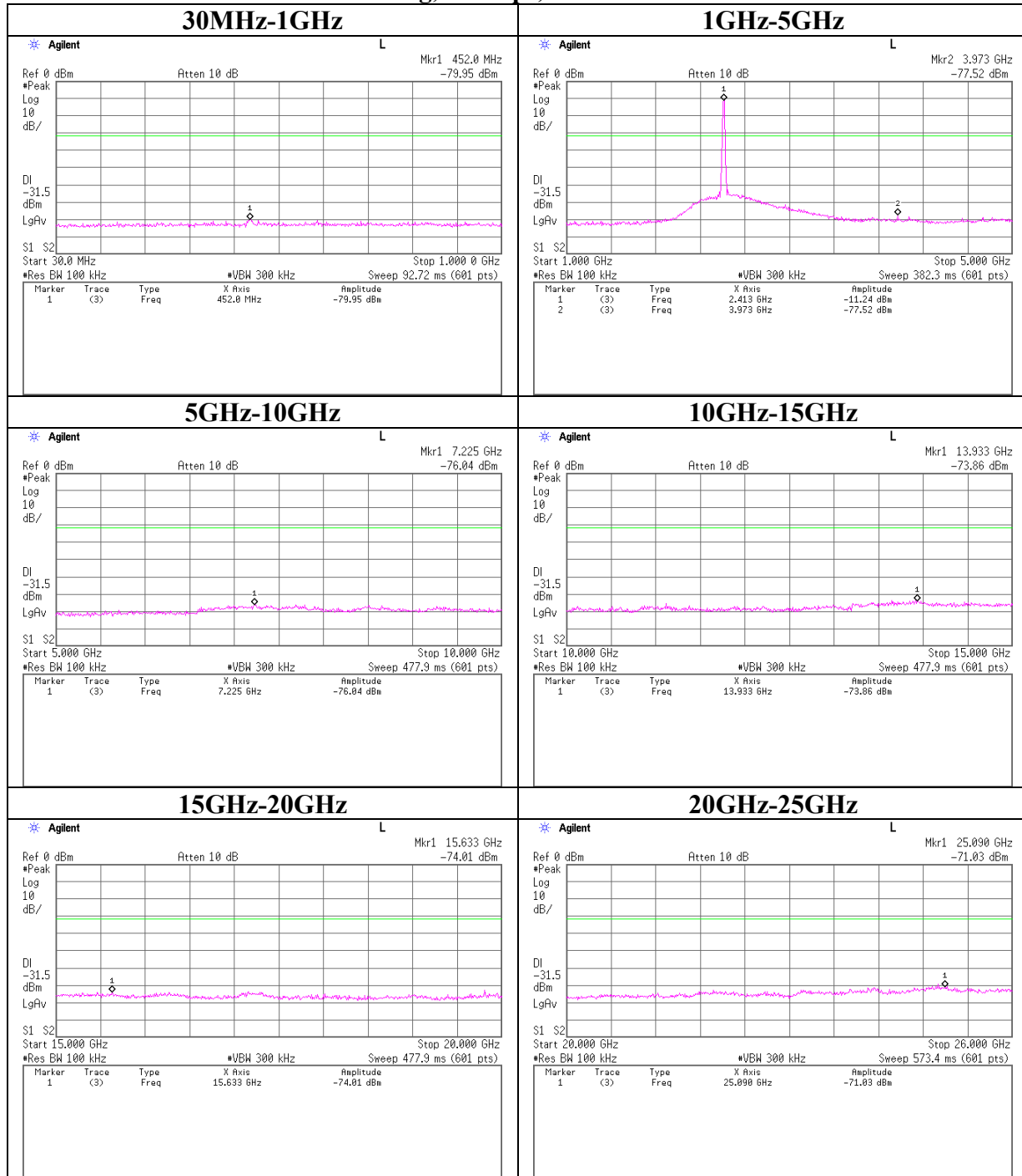

**Conducted Spurious Emission(DSSS and other forms of modulation)**  
**11g, 54Mbps, Ch : Mid**

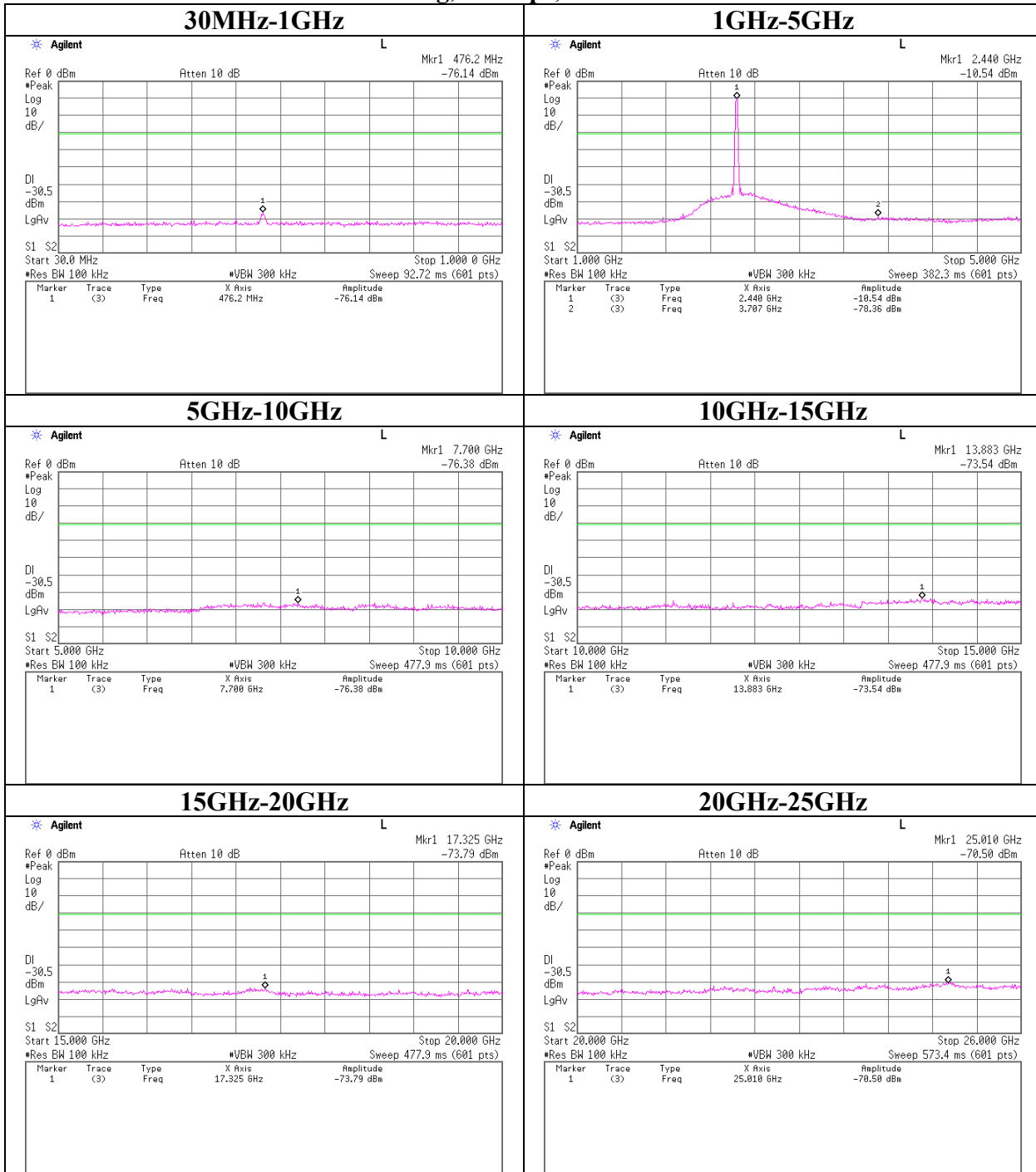

**Conducted Spurious Emission(DSSS and other forms of modulation)**  
**11g, 54Mbps, Ch : High**

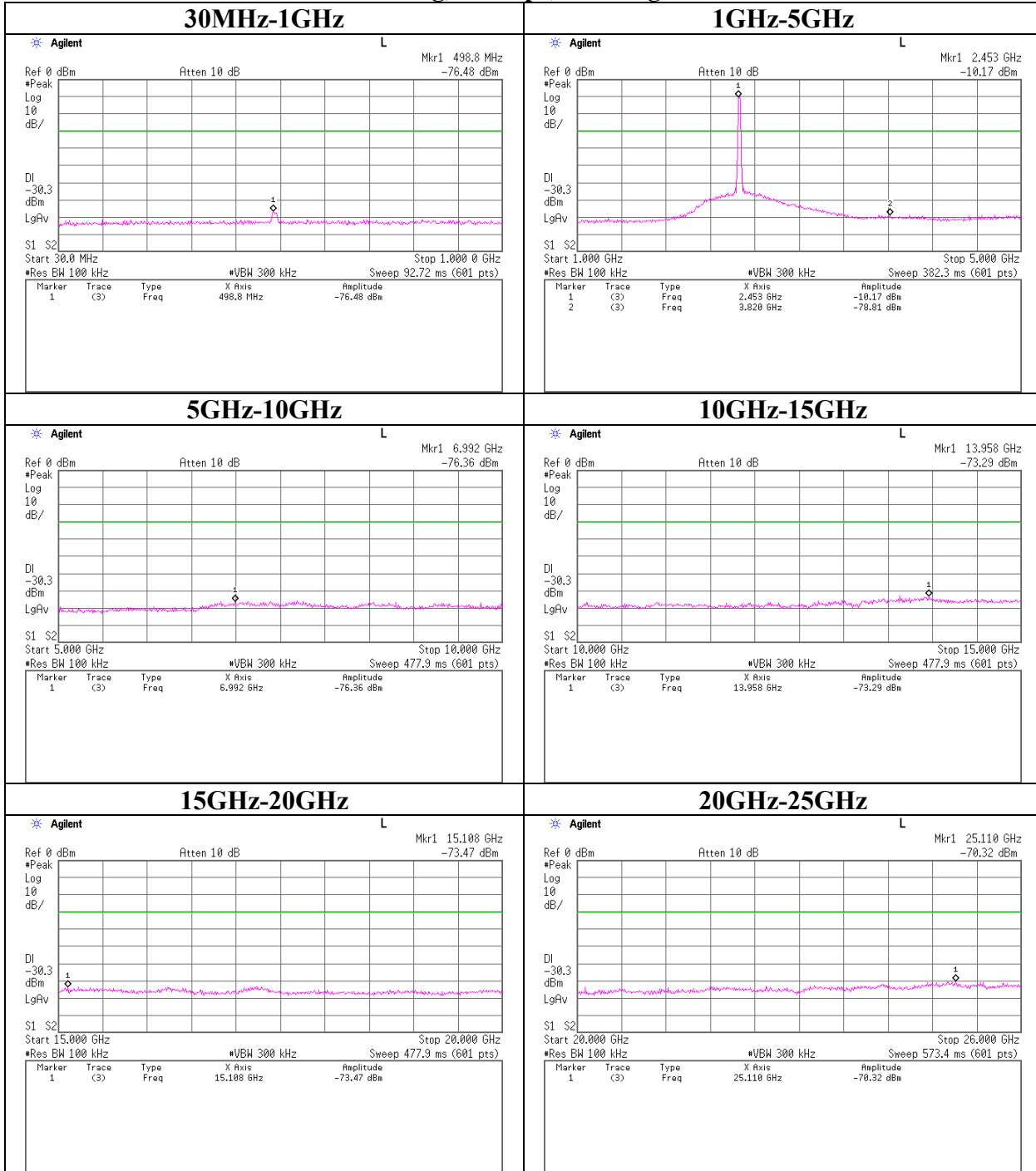



**Conducted emission Band Edge compliance (DSSS and other forms of modulation)**  
**11b, 11Mbps**

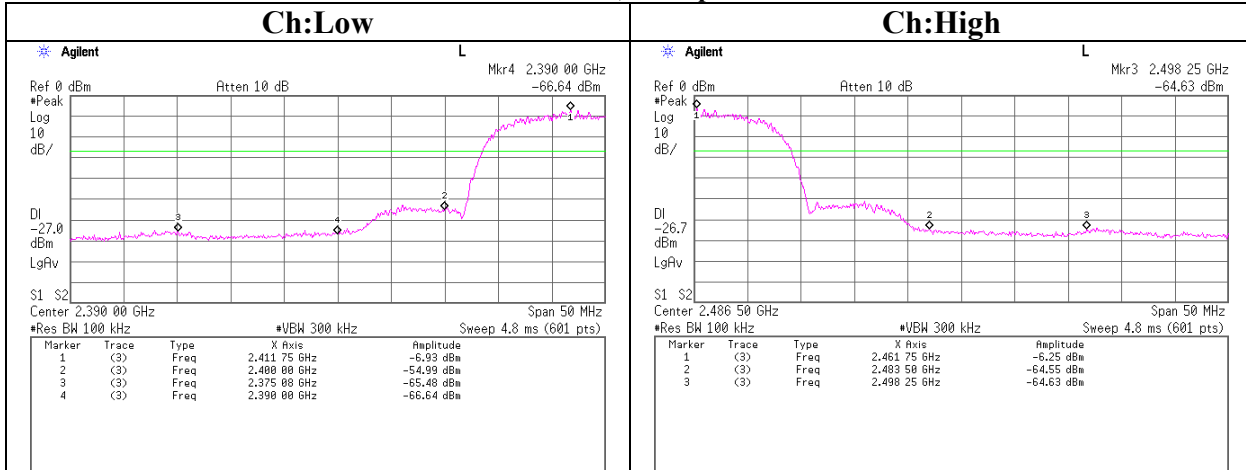

**11g, 54Mbps**

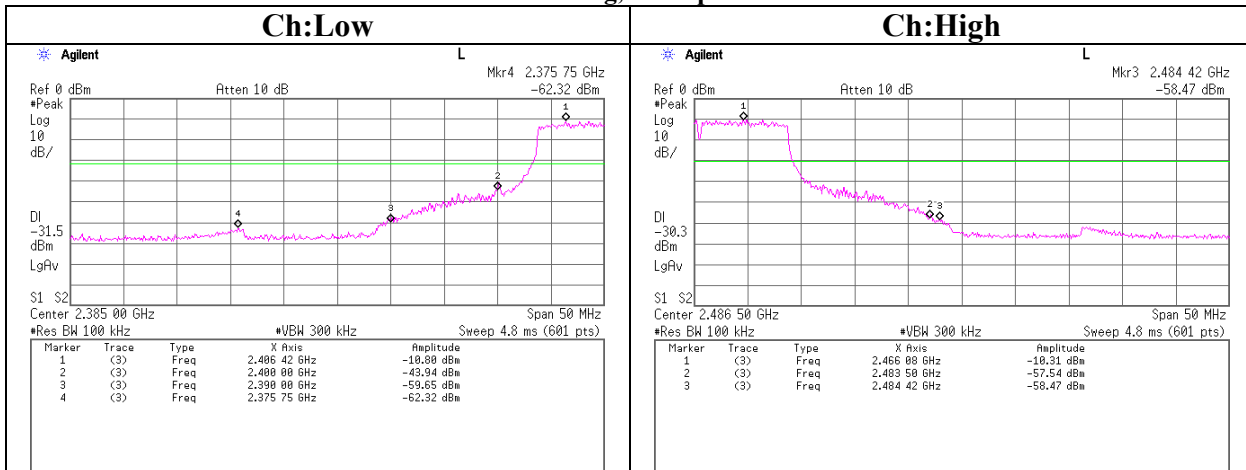

**Power Density (DSSS and other forms of modulation )**

UL Apex Co., Ltd.  
 Head Office EMC Lab. No.3 Measurement Room

Company	: CANON INC.	REPORT NO	: 25IE0087-HO
Equipment	: WLAN module for printer	REGULATION	: FCC Part15 Subpart C 15.247(e)
Model	: K30254	TEST DISTANCE	: -
Sample No.	: 08F2E2	DATE	: 06/15/2005
Power	: DC 3.35V (AC adapter input AC120V/60Hz)	TEMPERATURE	: 25 deg.C.
Mode	: Tx(ch1,6,11)	HUMIDITY	: 51%
		ENGINEER	: Kenichi Adachi

[IEEE802.11b] (11Mbps)

Ch	Freq. [MHz]	Reading [dBm]	Cable Loss [dB]	Atten. [dB]	Result [dBm]	Limit [dBm]	Margin [dB]
Low	2412.7	-21.73	0.93	9.91	-10.89	8.0	18.9
Mid	2437.7	-20.95	0.93	9.91	-10.11	8.0	18.1
High	2462.4	-20.83	0.93	9.91	-9.99	8.0	18.0

Sample Calculation:

Result = Reading + Cable Loss (spplied by customer) + Attenuator

[IEEE802.11g] (54Mbps)

Ch	Freq. [MHz]	Reading [dBm]	Cable Loss [dB]	Atten. [dB]	Result [dBm]	Limit [dBm]	Margin [dB]
Low	2412.4	-25.79	0.93	9.91	-14.95	8.0	23.0
Mid	2437.6	-25.39	0.93	9.91	-14.55	8.0	22.6
High	2461.4	-24.74	0.93	9.91	-13.90	8.0	21.9

Sample Calculation:

Result = Reading + Cable Loss (supplied by customer)+ Attenuator

**Power Density(DSSS and other forms of modulation)**  
**11b, 11Mbps**

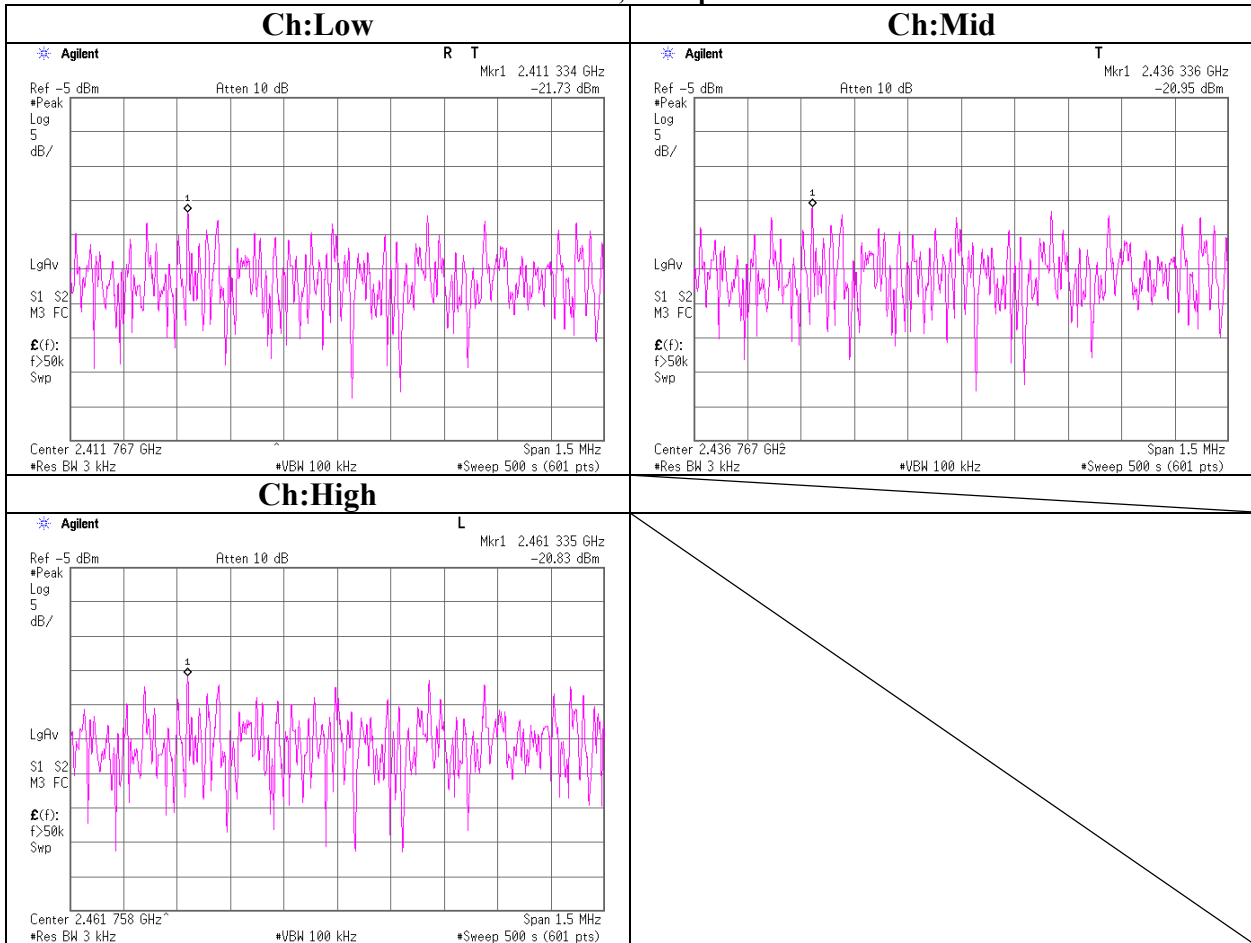

**Power Density(DSSS and other forms of modulation)**  
**11g, 54Mbps**

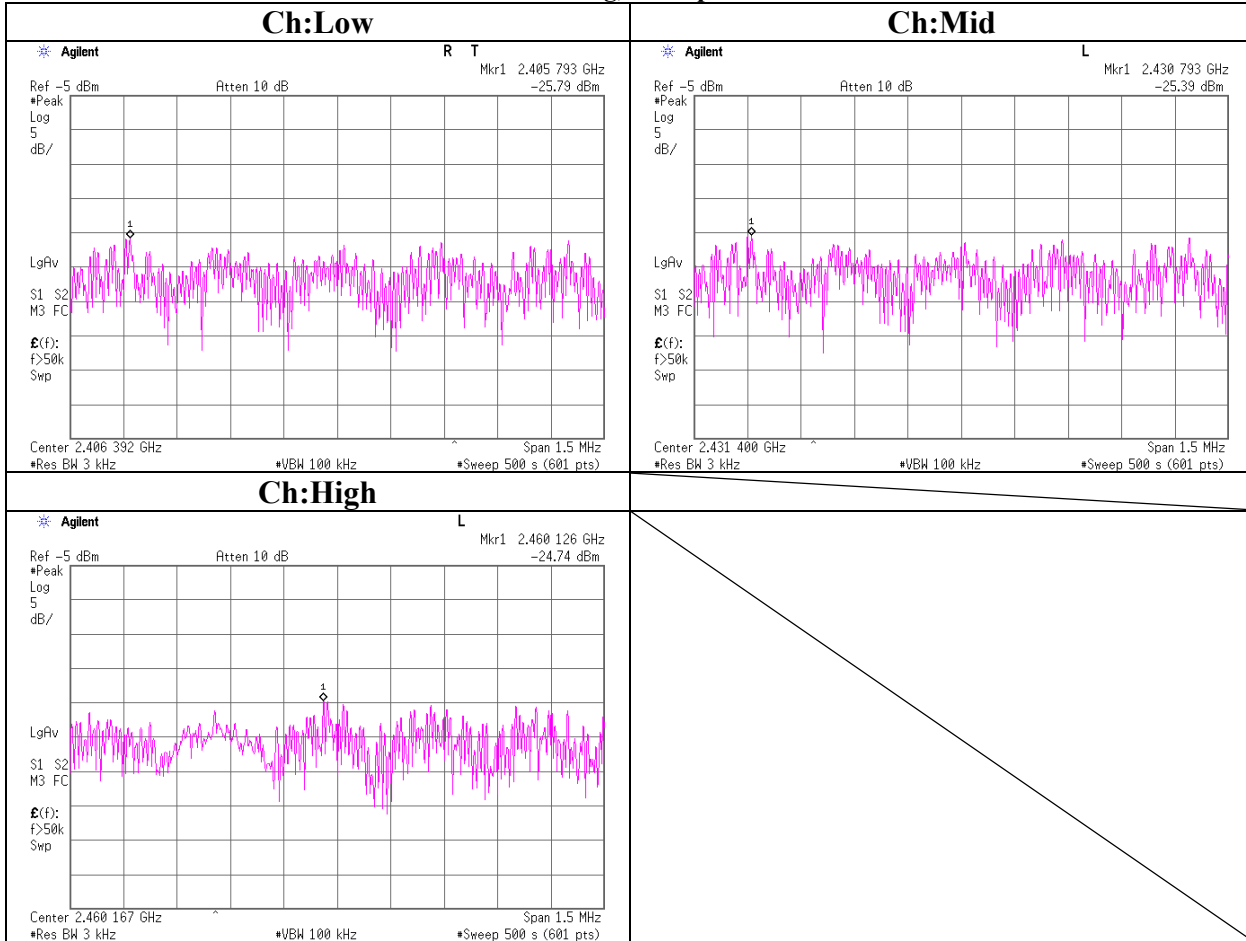

**99%Occupied Bandwidth(DSSS and other forms of modulation)**  
**11b, 11Mbps**

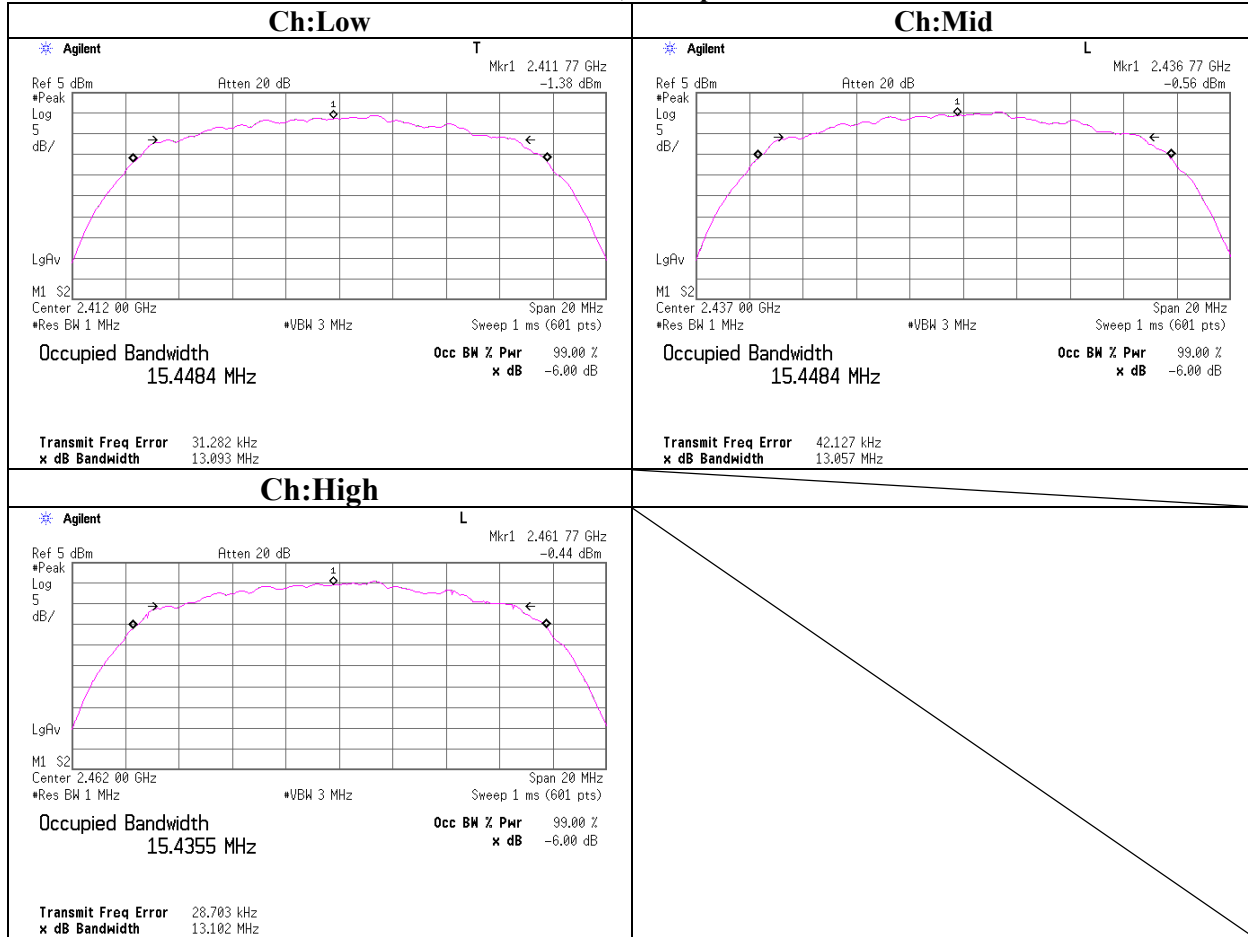

**99% Occupied Bandwidth(DSSS and other forms of modulation)**

**11g, 54Mbps**

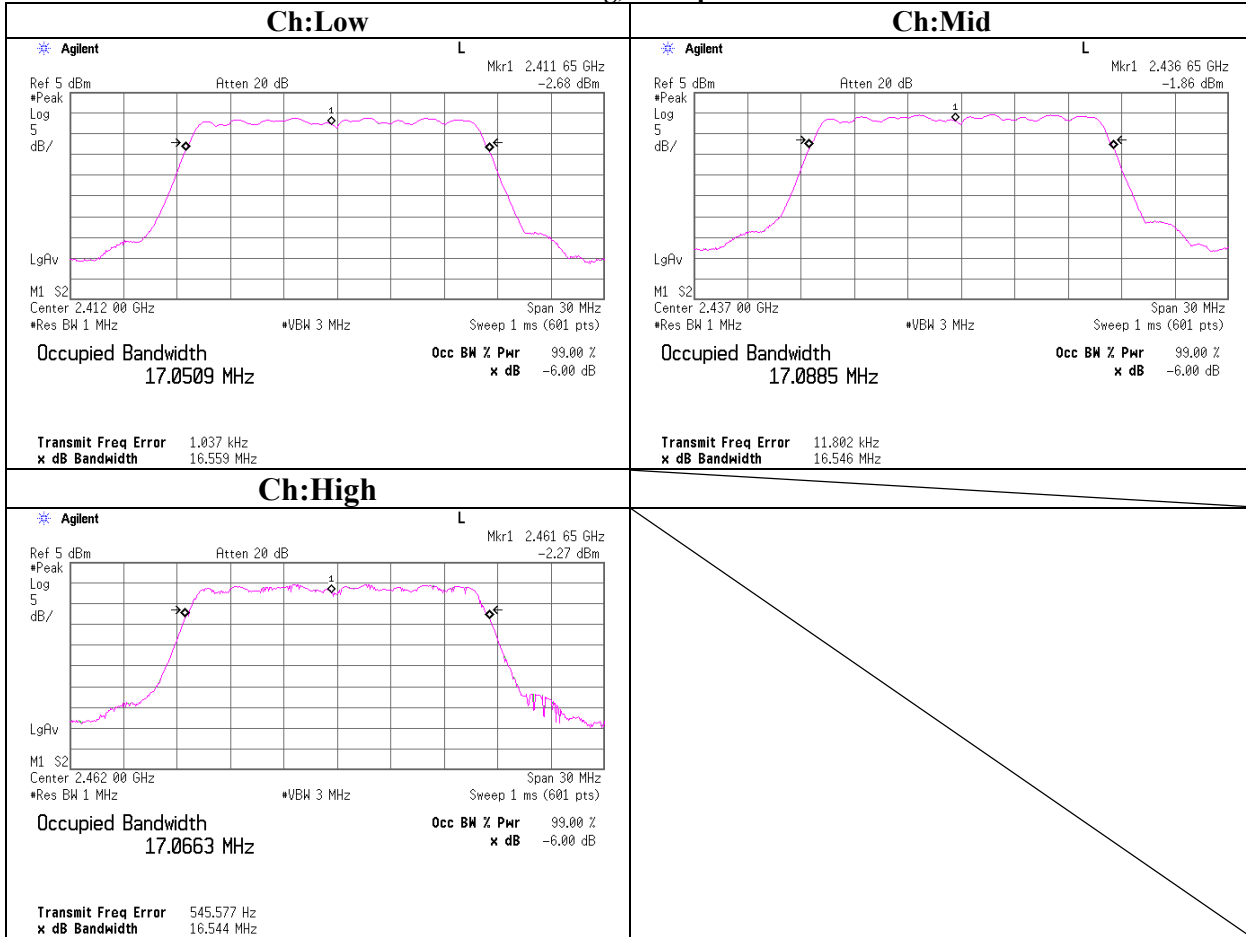

#### **APPENDIX 4: Reference data [Characteristic and destructive tests]**

The module has a voltage regulator circuit inside and the regulated voltage is provided with IC chip and the circuit which determines RF characteristics.

However, only RF power amplifier is operated with the voltage (+3.35V) supplied from outside directly.

We performed tests with the following conditions,

- Low threshold voltage ; until transmission stops
- High voltage: +5V (50% up of rated voltage +3.35V),

Then we confirmed that there were no changes in the transmission bandwidth, the transmission power, and the spurious emission of

frequencies adjacent to carrier by supply voltage.

In addition, we found no abnormal signal.

See the following data:

---

**UL Apex Co., Ltd.**

**Head Office EMC Lab.**

4383-326 Asama-cho, Ise-shi, Mie-ken 516-0021 JAPAN

Telephone : +81 596 24 8116

Facsimile : +81 596 24 8124

MF060b(01.06.05)

**Maximum Peak OutPut Power and 20dB Band Width**  
**Characteristic and destructive tests**  
**IEEE802.11g 54Mbps (Worst Case)**

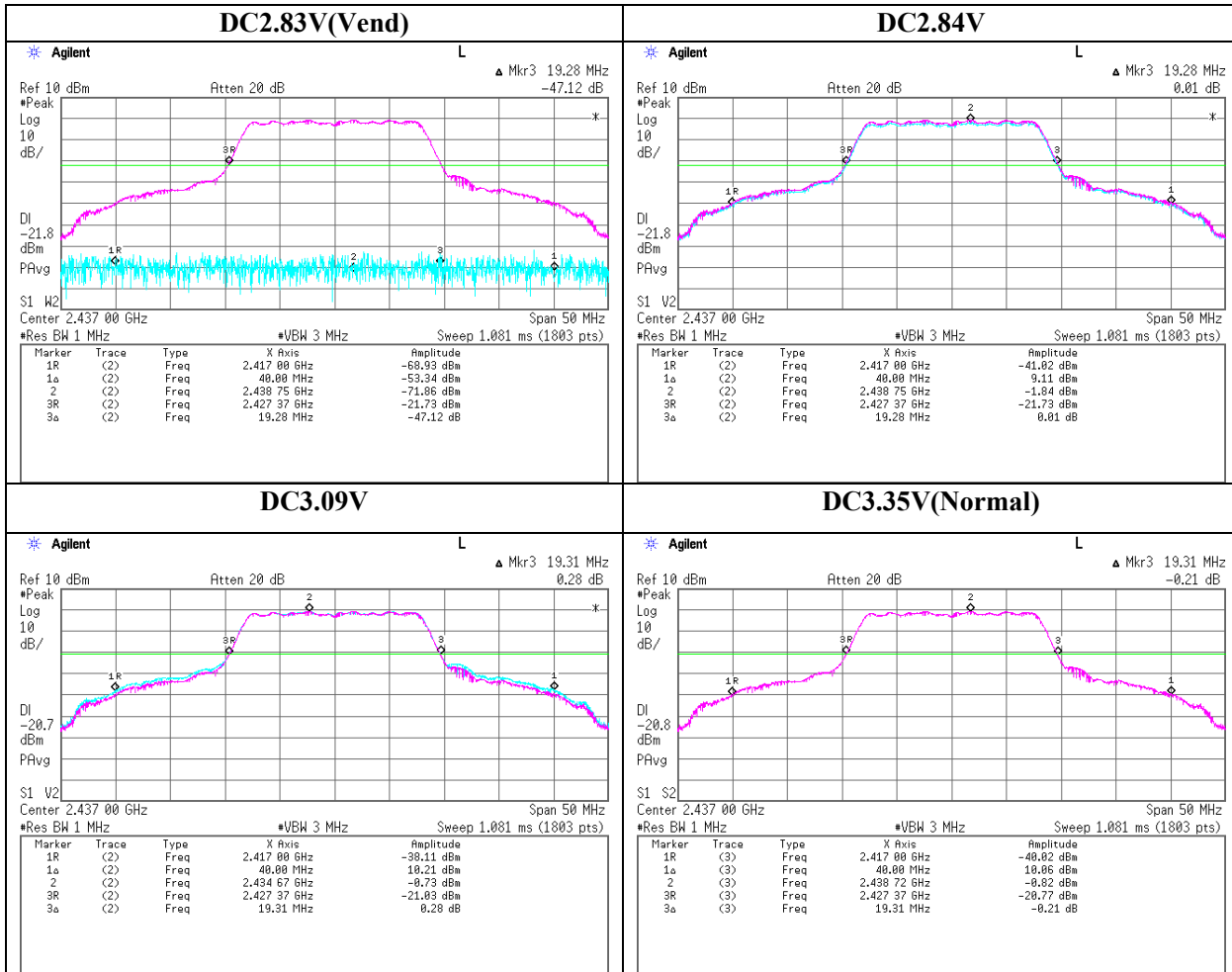



**Maximum Peak OutPut Power and 20dB Band Width**  
**Characteristic and destructive tests**  
**IEEE802.11g 54Mbps (Worst Case)**

