





# RADIO TEST REPORT

## Test Report No. 14615663S-C

Customer	CANON INC.
Description of EUT	Wireless LAN Module
Model Number of EUT	FM3-L998
FCC ID	AZDFM3L998
Test Regulation	FCC Part 15 Subpart E
Test Result	Complied
Issue Date	September 6, 2023
Remarks	WLAN (5 GHz band) part DFS test only (* Client without radar detection)

Representative Test Engineer	Approved By
	
Kenichi Adachi Engineer	Toyokazu Imamura Leader
 	
CERTIFICATE 1266.03	
<input type="checkbox"/> The testing in which "Non-accreditation" is displayed is outside the accreditation scopes in UL Japan, Inc.	
<input checked="" type="checkbox"/> There is no testing item of "Non-accreditation".	

Report Cover Page - Form-ULID-003532 (DCS:13-EM-F0429) Issue# 22.0

---

## **ANNOUNCEMENT**

- This test report shall not be reproduced in full or partial, without the written approval of UL Japan, Inc.
- The results in this report apply only to the sample tested. (Laboratory was not involved in sampling.)
- This sample tested is in compliance with the limits of the above regulation.
- The test results in this test report are traceable to the national or international standards.
- This test report must not be used by the customer to claim product certification, approval, or endorsement by the A2LA accreditation body.
- This test report covers Radio technical requirements.  
It does not cover administrative issues such as Manual or non-Radio test related Requirements. (if applicable)
- The all test items in this test report are conducted by UL Japan, Inc. Shonan EMC Lab.
- The opinions and the interpretations to the result of the description in this report are outside scopes where UL Japan, Inc. has been accredited.
- The information provided from the customer for this report is identified in Section 1.
- For test report(s) referred in this report, the latest version (including any revisions) is always referred.

## **REVISION HISTORY**

### **Original Test Report No. 14615663S-C**

Revision	Test Report No.	Date	Page Revised Contents
- (Original)	14615663S-C	September 6, 2023	-

## Reference: Abbreviations (Including words undescribed in this report)

A2LA	The American Association for Laboratory Accreditation	ICES	Interference-Causing Equipment Standard
AC	Alternating Current	IEC	International Electrotechnical Commission
AFH	Adaptive Frequency Hopping	IEEE	Institute of Electrical and Electronics Engineers
AM	Amplitude Modulation	IF	Intermediate Frequency
Amp, AMP	Amplifier	ILAC	International Laboratory Accreditation Conference
ANSI	American National Standards Institute	ISED	Innovation, Science and Economic Development Canada
Ant, ANT	Antenna	ISO	International Organization for Standardization
AP	Access Point	JAB	Japan Accreditation Board
ASK	Amplitude Shift Keying	LAN	Local Area Network
Atten., ATT	Attenuator	LIMS	Laboratory Information Management System
AV	Average	MCS	Modulation and Coding Scheme
BPSK	Binary Phase-Shift Keying	MRA	Mutual Recognition Arrangement
BR	Bluetooth Basic Rate	N/A	Not Applicable
BT	Bluetooth	NIST	National Institute of Standards and Technology
BT LE	Bluetooth Low Energy	NS	No signal detect.
BW	BandWidth	NSA	Normalized Site Attenuation
Cal Int	Calibration Interval	NVLAP	National Voluntary Laboratory Accreditation Program
CCK	Complementary Code Keying	OBW	Occupied Band Width
Ch., CH	Channel	OFDM	Orthogonal Frequency Division Multiplexing
CISPR	Comite International Special des Perturbations Radioelectriques	P/M	Power meter
CW	Continuous Wave	PCB	Printed Circuit Board
DBPSK	Differential BPSK	PER	Packet Error Rate
DC	Direct Current	PHY	Physical Layer
D-factor	Distance factor	PK	Peak
DFS	Dynamic Frequency Selection	PN	Pseudo random Noise
DQPSK	Differential QPSK	PRBS	Pseudo-Random Bit Sequence
DSSS	Direct Sequence Spread Spectrum	PSD	Power Spectral Density
EDR	Enhanced Data Rate	QAM	Quadrature Amplitude Modulation
EIRP, e.i.r.p.	Equivalent Isotropically Radiated Power	QP	Quasi-Peak
EMC	ElectroMagnetic Compatibility	QPSK	Quadrature -Phase Shift Keying
EMI	ElectroMagnetic Interference	RBW	Resolution Band Width
EN	European Norm	RDS	Radio Data System
ERP, e.r.p.	Effective Radiated Power	RE	Radio Equipment
EU	European Union	RF	Radio Frequency
EUT	Equipment Under Test	RMS	Root Mean Square
Fac.	Factor	RSS	Radio Standards Specifications
FCC	Federal Communications Commission	Rx	Receiving
FHSS	Frequency Hopping Spread Spectrum	SA, S/A	Spectrum Analyzer
FM	Frequency Modulation	SG	Signal Generator
Freq.	Frequency	SVSWR	Site-Voltage Standing Wave Ratio
FSK	Frequency Shift Keying	TR	Test Receiver
GFSK	Gaussian Frequency-Shift Keying	Tx	Transmitting
GNSS	Global Navigation Satellite System	VBW	Video BandWidth
GPS	Global Positioning System	Vert.	Vertical
Hori.	Horizontal	WLAN	Wireless LAN

---

<b>CONTENTS</b>	<b>PAGE</b>
<b>SECTION 1: Customer Information</b> .....	<b>5</b>
<b>SECTION 2: Equipment Under Test (EUT)</b> .....	<b>5</b>
<b>SECTION 3: Scope of Report</b> .....	<b>7</b>
<b>SECTION 4: Test specification, Procedures &amp; Results</b> .....	<b>7</b>
<b>SECTION 5: Operation of EUT during testing</b> .....	<b>12</b>
<b>SECTION 6: Channel Move Time, Channel Closing Transmission Time</b> .....	<b>18</b>
<b>SECTION 7: Non-Occupancy Period</b> .....	<b>20</b>
<b>APPENDIX 1: Test Instruments</b> .....	<b>22</b>
<b>APPENDIX 2: Photographs of Test Setup</b> .....	<b>23</b>
DFS tests .....	<b>23</b>

## **SECTION 1: Customer Information**

Company Name	CANON INC.
Address	16-1, Shimonoge 3-chome, Takatsu-ku, Kawasaki-shi, Kanagawa 213-8512, Japan
Telephone Number	+81 3-3758-2111
Contact Person	Yoshihiro Funamizu

The information provided from the customer is as follows;

- Customer, Description of EUT, Model Number of EUT, FCC ID on the cover and other relevant pages
- Operating/Test Mode(s) (Mode(s)) on all the relevant pages
- SECTION 1: Customer Information
- SECTION 2: Equipment Under Test (EUT) other than the Receipt Date and Test Date
- SECTION 5: Operation of EUT during testing

\* The laboratory is exempted from liability of any test results affected from the above information in SECTION 2 and 5.

## **SECTION 2: Equipment Under Test (EUT)**

### **2.1 Identification of EUT**

Description	Wireless LAN Module
Model Number	FM3-L998
Serial Number	Refer to SECTION 4.2
Condition	Production prototype (Not for Sale: This sample is equivalent to mass-produced items.)
Modification	No Modification by the test lab
Receipt Date	January 23, 2023
Test Date	April 27, 2023

### **2.2 Product Description**

#### **General Specification**

Rating	DC 5.0 V
Operating temperature	10 deg. C to 50 deg. C

**Radio Specification**

**WLAN (IEEE802.11b/11g/11n-20/11ax-20)**

Equipment Type	Transceiver
Frequency of Operation	2412 MHz to 2462 MHz
Type of Modulation	DSSS, OFDM, OFDMA
Antenna Type	Monopole Antenna
Antenna Gain	Ant A: -0.75 dBi Ant B: -0.26 dBi
Directional Gain *1)	2.51 dBi

**WLAN (IEEE802.11a/11n-20/11ac-20/11ax-20)**

Equipment Type	Transceiver	
Frequency of Operation	20 MHz Band:	5180 MHz to 5240 MHz 5260 MHz to 5320 MHz 5500 MHz to 5700 MHz 5745 MHz to 5825 MHz
Type of Modulation	OFDM, OFDMA	
Antenna Type	Monopole Antenna	
Antenna Gain	W52 5150 MHz to 5250 MHz:	Ant A: 0.67 dBi (W52) Ant B: 0.91 dBi (W52)
	W53 5250 MHz to 5350 MHz	Ant A: 0.85 dBi (W53) Ant B: 1.50 dBi (W53)
	W56 5470 MHz to 5725 MHz:	Ant A: 0.97 dBi (W56) Ant B: 1.59 dBi (W56)
	W58 5725 MHz to 5850 MHz:	Ant A: 1.15 dBi (W58) Ant B: 1.50 dBi (W58)
Directional Gain *1)	W52 5150 MHz to 5250 MHz:	3.81 dBi
	W53 5250 MHz to 5350 MHz	4.20 dBi
	W56 5470 MHz to 5725 MHz:	4.30 dBi
	W58 5725 MHz to 5850 MHz:	4.34 dBi

\*1) Directional Antenna Gain =  $10 \log\left\{\left(10^{\frac{G_{ANT1}}{20}} + 10^{\frac{G_{ANT2}}{20}}\right)^2 / 2\right\}$

\* Following channels are not used.  
- 20 MHz Bandwidth (5600 MHz - 5640 MHz)

---

### **SECTION 3: Scope of Report**

This report only covers DFS requirement, as specified by the following referenced procedures.

### **SECTION 4: Test specification, Procedures & Results**

#### **4.1 Test Specification**

Test Specification	FCC Part 15 Subpart E The latest version on the first day of the testing period
Title	FCC 47 CFR Part 15 Radio Frequency Device Subpart E Unlicensed National Information Infrastructure Devices Section 15.407 General technical requirements

Test Specification	KDB 905462 D02 UNII DFS Compliance Procedure New Rules v02
Title	COMPLIANCE MEASUREMENT PROCEDURES FOR UNLICENSED-NATIONAL INFORMATION INFRASTRUCTURE DEVICES OPERATING IN THE 5250-5350MHz AND 5470-5725MHz BANDS INCORPORATING DYNAMIC FREQUENCY SELECTION

Test Specification	KDB905462 D03 Client Without DFS New Rules v01r02
Title	U-NII CLIENT DEVICES WITHOUT RADAR DETECTION CAPABILITY

Test Specification	KDB905462 D04 Operational Modes for DFS Testing New Rules v01
Title	OPERATIONAL MODES SUGGESTED FOR DFS TESTING

#### **FCC Part 15.31 (e)**

The RF Module has its own regulator. The RF Module is constantly provided voltage through the regulator regardless of input voltage. Therefore, this EUT complies with the requirement.

#### **FCC Part 15.203 Antenna requirement**

The antenna is not removable from the EUT. Therefore, the equipment complies with the antenna requirement of Section 15.203.

4.2 Procedures and Results

Table 1: Applicability of DFS Requirements

< Client mode >

Requirement	Operating Mode	Test Procedures & Limits	Deviation	Results
	Client without Radar Detection			
U-NII Detection Bandwidth	Not required	KDB905462 D02 UNII DFS Compliance Procedures New Rules v02	N/A	N/A
Initial Channel Availability Check Time	Not required	FCC15.407 (h)	N/A	N/A
		KDB905462 D02 UNII DFS Compliance Procedures New Rules v02		
		RSS-247 6.3		
Radar Burst at the Beginning of the Channel Availability Check Time	Not required	FCC15.407 (h)	N/A	N/A
		KDB905462 D02 UNII DFS Compliance Procedures New Rules v02		
		RSS-247 6.3		
Radar Burst at the End of the Channel Availability Check Time	Not required	FCC15.407 (h)	N/A	N/A
		KDB905462 D02 UNII DFS Compliance Procedures New Rules v02		
		RSS-247 6.3		
In-Service Monitoring for Channel Move Time, Channel Closing Transmission Time	Yes	FCC15.407 (h)	N/A	Complied
		KDB905462 D02 UNII DFS Compliance Procedures New Rules v02		
		RSS-247 6.3		
In-Service Monitoring for Non-Occupancy period	Yes *	FCC15.407 (h)	N/A	Complied
		KDB905462 D02 UNII DFS Compliance Procedures New Rules v02		
		RSS-247 6.3		
Statistical Performance Check	Not required	FCC15.407 (h)	N/A	N/A
		KDB905462 D02 UNII DFS Compliance Procedures New Rules v02		
Note: UL Japan, Inc.'s EMI Work Procedures: Work Instructions-ULID-003591 and Work Instructions-ULID-003593.				

\*Although this test was not required in FCC, KDB 905462 D02, it was performed as additional test.



**Table 2 DFS Detection Thresholds for Master Devices and Client Devices With Radar Detection**

Maximum Transmit Power	Value (See Notes 1,2, and 3)
≥ 200 milliwatt	-64 dBm
< 200 milliwatt and power spectral density < 10 dBm/MHz	-62 dBm
< 200 milliwatt that do not meet the power spectral density requirement	-64 dBm
<p>Note 1: This is the level at the input of the receiver assuming a 0 dBi receive antenna.            Note 2: Throughout these test procedures an additional 1 dB has been added to the amplitude of the test transmission waveforms to account for variations in measurement equipment. This will ensure that the test signal is at or above the detection threshold level to trigger a DFS response.            Note 3: EIRP is based on the highest antenna gain. For MIMO devices refer to KDB Publication 662911 D01.</p>	

**Table 3 DFS Response Requirement Values**

Parameter	Value
Non-occupancy period	Minimum 30 minutes
Channel Availability Check Time	60 seconds
Channel Move Time	10 seconds See Note 1
Channel Closing Transmission Time	200 milliseconds + an aggregate of 60 milliseconds over remaining 10 second period. See Notes 1 and 2
U-NII Detection Bandwidth	Minimum 100 % of the U-NII 99 % transmission power bandwidth See Note 3
<p><b>Note 1:</b> Channel Move Time and the Channel Closing Transmission Time should be performed with Radar Type 0. The measurement timing begins at the end of the Radar Type 0 burst.  <b>Note 2:</b> The Channel Closing Transmission Time is comprised of 200 milliseconds starting at the beginning of the Channel Move Time plus any additional intermittent control signals required to facilitate a Channel move (an aggregate of 60 milliseconds) during the remainder of the 10 second period. The aggregate duration of control signal will not count quiet periods in between transmissions.  <b>Note 3:</b> During the U-NII Detection Bandwidth detection test, radar type 0 should be used. For each frequency step the minimum percentage of detection is 90 percent. Measurements are performed with no data traffic.</p>	

**Table 4 Short Pulse Radar Test Waveform**

Radar Type	Pulse Width (μs)	PRI (μs)	Number of Pulses	Minimum Percentage of Successful Detection	Minimum Number of Trials
0	1	1428	18	See Note 1	See Note 1
1	1	Test A: 15 unique PRI values randomly selected from the list of 23 PRI values in Table 5a	Roundup $\{((1/3 \cdot 60) \cdot (19 \cdot 10^6 / \text{PRI}_{\mu\text{s}}))\}$	60 %	30
		Test B: 15 unique PRI values randomly selected within the range of 518-3066 μs, with a minimum increment of 1 μs, excluding PRI values selected in Test A			
2	1-5	150-230	23-29	60 %	30
3	6-10	200-500	16-18	60 %	30
4	11-20	200-500	12-16	60 %	30
Aggregate (Rader Types 1-4)				80 %	120
Note 1: Short Pulse Radar Type 0 should be used for the detection bandwidth test, channel move time, and channel closing time tests.					

**Table 5 Long Pulse Radar Test Waveform**

Radar Type	Pulse Width (μs)	Chip Width (MHz)	PRI (μs)	Number of Pulses per Burst	Number of Burst	Minimum Percentage of Successful Detection	Minimum Number of Trials
5	50-100	5 - 20	1000-2000	1-3	8-20	80 %	30

**Table 6 Frequency Hopping Radar Test Waveform**

Radar Type	Pulse Width (μs)	PRI (μs)	Pulse per Hop (kHz)	Hopping Rate (kHz)	Hopping Sequence Length (ms)	Minimum Percentage of Successful Detection	Minimum Number of Trials
6	1	333	9	0.333	300	70 %	30

#### 4.3 Addition to Standard

No addition, exclusion nor deviation has been made from the standard.

#### 4.4 Uncertainty

Measurement uncertainty is not taken into account when stating conformity with a specified requirement.  
Note: When margins obtained from test results are less than the measurement uncertainty, the test results may exceed the limit.

The following uncertainties have been calculated to provide a confidence level of 95 % using a coverage factor  $k=2$ .

Time Measurement uncertainty for this test was:  $(\pm) 0.012\%$

#### 4.5 Test Location

UL Japan, Inc. Shonan EMC Lab.  
1-22-3, Megumigaoka, Hiratsuka-shi, Kanagawa-ken 259-1220 Japan  
Telephone: +81 463 50 6400  
A2LA Certificate Number: 1266.03  
(FCC test firm registration number: 626366, ISED lab company number: 2973D / CAB identifier: JP0001)

Test site	IC Registration Number	Width x Depth x Height (m)	Size of reference ground plane (m) / horizontal conducting plane	Maximum measurement distance
No.1 Semi-anechoic chamber	2973D-1	20.6 x 11.3 x 7.65	20.6 x 11.3	10 m
No.2 Semi-anechoic chamber	2973D-2	20.6 x 11.3 x 7.65	20.6 x 11.3	10 m
No.3 Semi-anechoic chamber	2973D-3	12.7 x 7.7 x 5.35	12.7 x 7.7	5 m
No.4 Semi-anechoic chamber	-	8.1 x 5.1 x 3.55	8.1 x 5.1	-
No.1 Shielded room	-	6.8 x 4.1 x 2.7	6.8 x 4.1	-
No.2 Shielded room	-	6.8 x 4.1 x 2.7	6.8 x 4.1	-
No.3 Shielded room	-	6.3 x 4.7 x 2.7	6.3 x 4.7	-
No.4 Shielded room	-	4.4 x 4.7 x 2.7	4.4 x 4.7	-
No.5 Shielded room	-	7.8 x 6.4 x 2.7	7.8 x 6.4	-
No.6 Shielded room	-	7.8 x 6.4 x 2.7	7.8 x 6.4	-
No.8 Shielded room	-	3.45 x 5.5 x 2.4	3.45 x 5.5	-
No.1 Measurement room	-	2.55 x 4.1 x 2.5	-	-

#### 4.6 Test Data, Test Instruments, and Test Set Up

Refer to APPENDIX.

## **SECTION 5: Operation of EUT during testing**

### **5.1 Operating Mode(s)**

The EUT, which is a Client Device without Radar detection capability, operates over the W53 and W56 Band.

The channel-loading of approximately 17 % or greater was used for testing, and its test data was transferred from the Master Device to the Client Device for all test configurations.

WLAN traffic is generated random data by ExPing program from the Master to the Client.

The EUT utilizes the 802.11a/n/ac/ax architecture, with a 20 MHz channel bandwidth.

The FCC ID for the Master Device used with EUT for DFS testing is LDK102087.

The lowest antenna assembly gain of all available antenna assemblies is 0.67 dBi

The rated output power of the Master unit is >200 mW (23 dBm). Therefore the required interference threshold level is -64 dBm. After correction for antenna gain and procedural adjustments, the required conducted threshold at the antenna port is  $-64 + 1 + 0 = -63.0$  dBm (threshold level + additional 1 dB + antenna gain).

It is impossible for users to change DFS control, because the DFS function is written on the firmware and users cannot access it.

The EUT was set by the software as follows:

Software name & version: ExPing.exe, version 1.33

## 5.2 Configuration and peripherals

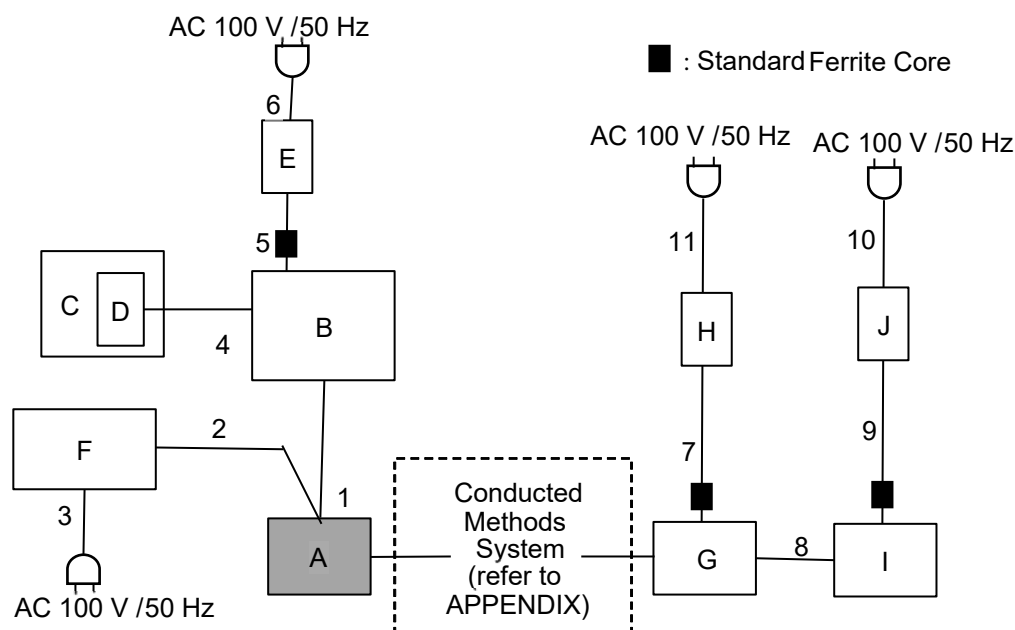

### Description of EUT and Support Equipment

No.	Item	Model Number	Serial Number	Manufacturer	Remarks
A	Wireless LAN Module	FM3-L998	2	CANON	EUT
B	Laptop Computer	7666-77J	LV-B8RC7 08/05	Lenovo	-
C	Portable HDD case	LGB-PBSU3	27A674402225 A	Logitec	-
D	Portable HDD	MQ01ABD100	4675S689S 13B HDKGB13A1A01	Toshiba	-
E	AC Adapter	42T4422	11S42T4422Z1ZF3D9C51LT	Lenovo	-
F	Power Supply(DC)	PW18-2ATP	19050351	TEXIO	-
G	Wireless LAN access point (master device)	AIR-CAP3702E-A-K9	FTX18227609	Cisco systems	-
H	AC Adapter	EADP-18MB	DAB1528MANP	Cisco systems	-
I	Laptop Computer	Type 20H1-CT01WW	PF-0UU34A	Lenovo	-
J	AC Adapter	ADLX45DLC2A	8SSA10E75792L1CZ75Z0W0R	Lenovo	-

### List of Cables Used

No.	Name	Length (m)	Shield		Remarks
			Cable	Connector	
1	USB	1.0	Shielded	Shielded	-
2	DC	2.0	Unshielded	Unshielded	-
3	AC	2.0	Unshielded	Unshielded	-
4	USB	1.0	Shielded	Shielded	-
5	DC	1.8	Unshielded	Unshielded	-
6	AC	0.9	Unshielded	Unshielded	-
7	DC	1.8	Unshielded	Unshielded	-
8	LAN	1.0	Unshielded	Unshielded	-
9	DC	1.8	Unshielded	Unshielded	-
10	AC	0.9	Unshielded	Unshielded	-
11	AC	0.9	Unshielded	Unshielded	-

### 5.3 Test and Measurement System

#### SYSTEM OVERVIEW

The measurement system is based on a conducted test method.

The software selects waveform parameters from within the bounds of the signal type on a random basis using uniform distribution. The short pulse types 1, 2, 3, and 4, the long pulse type 5, and the frequency hopping type 6 parameters are randomized at run-time.

The signal monitoring equipment consists of a spectrum analyzer with the capacity to display 8001 bins on the horizontal axis. A time-domain resolution of 2 ms/bin is achievable with a 16 second sweep time, meeting the 10 seconds short pulse reporting criteria. The aggregate ON time is calculated by multiplying the number of bins above a threshold during a particular observation period by the dwell time per bin, with the analyzer set to peak detection.

#### FREQUENCY HOPPING RADAR WAVEFORM GENERATING SUBSYSTEM

The first 100 frequencies are selected out of the hopping sequence of the randomized 475 hop frequencies.

Only a *Burst* that has the frequency falling within the receiver bandwidth of the tested U-NII device is selected among those frequencies. (Frequency-domain simulation). The radar waveform generated at the start time of the selected *Burst* (Time-domain simulation) is download to the Signal Generator. If all of the randomly selected 100 frequencies do not fall within the receiver bandwidth of the U-NII device, the radar waveform is not used for the test.

**CONDUCTED METHODS SYSTEM BLOCK DIAGRAM**

<Client mode>

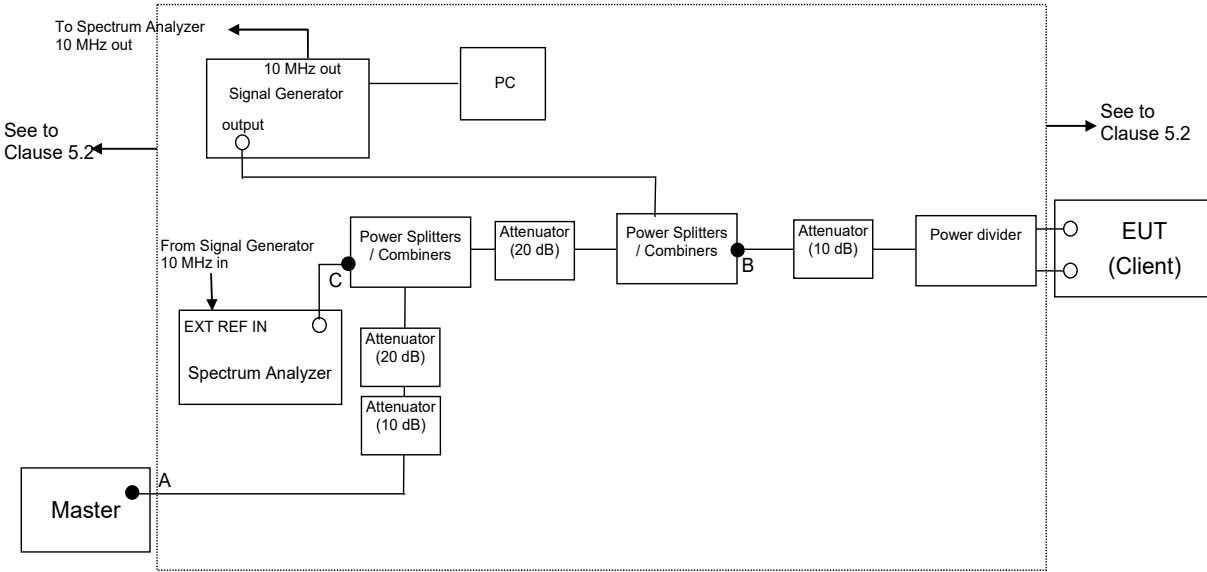

**MEASUREMENT SYSTEM FREQUENCY REFERENCE**

Lock the signal generator and the spectrum analyzer to the same reference sources as follows: Connect the 10 MHz OUT on the signal generator to the EXT REF IN on the spectrum analyzer and set the spectrum analyzer Ext to On.

## **SYSTEM CALIBRATION**

**Step 1:** Set the system as shown in Figure 3 of KDB905462 D02, 7.2.2.

**Step 2:** Adjust each attenuator to fulfill the following three conditions:

- WLAN can be communicated, and
- Rader detection threshold level is bigger than Client Device traffic level on the spectrum analyzer, and
- Master Device traffic level is not displayed on the spectrum analyzer.

**Step 3:** Terminate 50 ohm at B and C points, and connect the spectrum analyzer to the point A. (See the figure on before page of Clause 5.3)

At the point A, adjust the signal generator and spectrum analyzer to the center frequency of the channel to be measured.

Download the applicable radar waveforms to the signal generator. Select the radar waveform, trigger a burst manually and measure the amplitude on the spectrum analyzer. Readjust the amplitude of the signal generator as required so that the peak level of the waveform is at a displayed level equal to the required or desired interference detection threshold.

Separate signal generator amplitude settings are determined as required for each radar type.

**Step 4:** Without changing any of the instrument settings, restore the system setting to Step 2 and adjust the Reference Level Offset of the spectrum analyzer to the level at Step 3.

By taking the above steps 1 to 4, the spectrum analyzer displays the level of the signal generator as received at the antenna ports of the Master Device.

See Clause 5.4 for Plots of Noise, Rader Waveforms, and WLAN signals.



5.4 Plots of Noise, Rader Waveforms, and WLAN signals

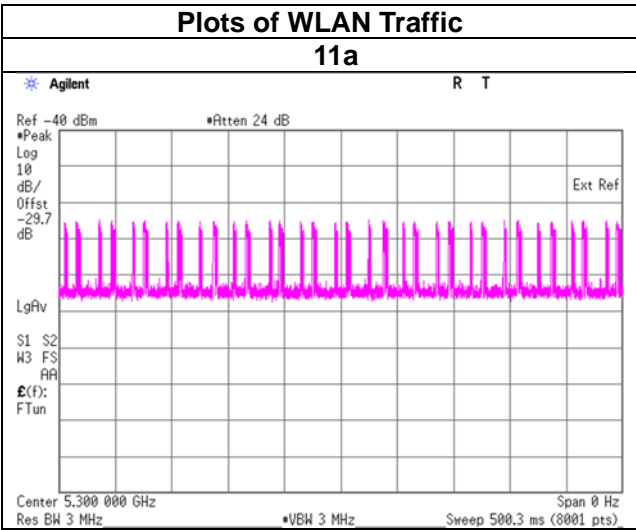
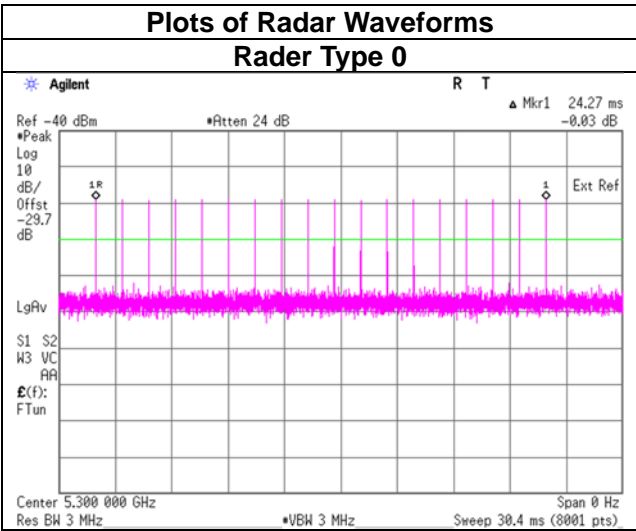
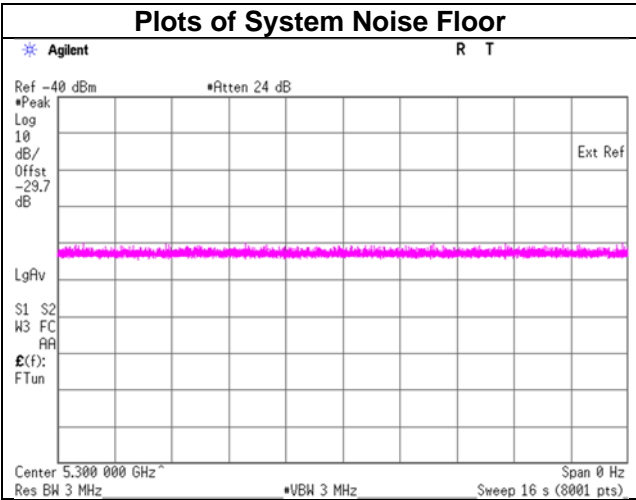

---

## **SECTION 6: Channel Move Time, Channel Closing Transmission Time**

### **6.1 Operating environment**

Test place                      Shonan EMC Lab. No.5 Shielded Room  
Date                              April 27, 2023  
Temperature/ Humidity        26 deg. C / 41 % RH  
Engineer                        Kenichi Adachi  
Mode                              11a

### **6.2 Test Procedure**

Transmit the data from the Master Device to the Client Device on the test Channel for the entire period of the test.

The Radar Waveform generator sends a Burst of pulses for one of the Radar Types 0 at levels defined on the Operating Channel. An additional 1 dB is added to the radar test signal to ensure it is at or above the DFS Detection Threshold, accounting for equipment variations/errors.

Observe the transmissions of the EUT at the end of the radar Burst on the Operating Channel for duration greater than 10 seconds.

### **6.3 Test data**

#### **11a**

Test Item	Unit	Measurement Time	Limit	Results
Channel Move Time *1)	[s]	0.090	10.000	Pass
Channel Closing Transmission Time *2)	[ms]	0	60	Pass

\*1) Channel Move Time is calculated as follows:

$$(\text{Channel Move Time}) = (\text{End of Transmission}) - (\text{End of Burst}) = 0.996 - 0.906$$

\*2) Channel Closing Transmission Time is calculated from (End of Burst + 200 ms) to (End of Burst + 10 s )

$$(\text{Channel Closing Transmission Time}) = (\text{Number of analyzer bins showing transmission}) \times (\text{dwell time per bin}) \\ = 0 \times 2 [\text{ms}]$$

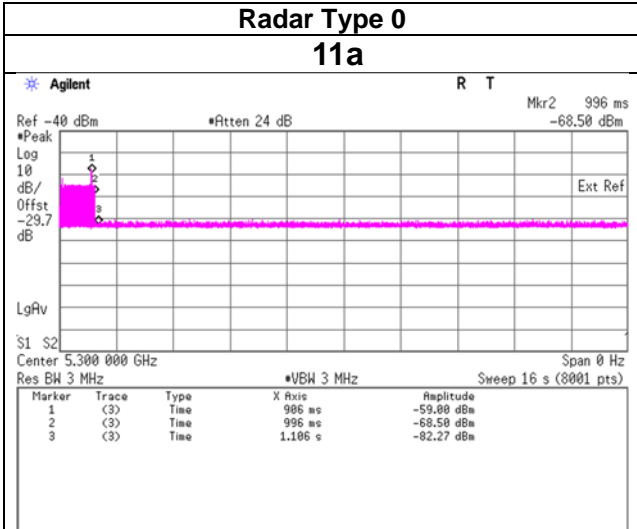

**Marker 1 : End of Burst**  
**Marker 2 : End of Transmission**

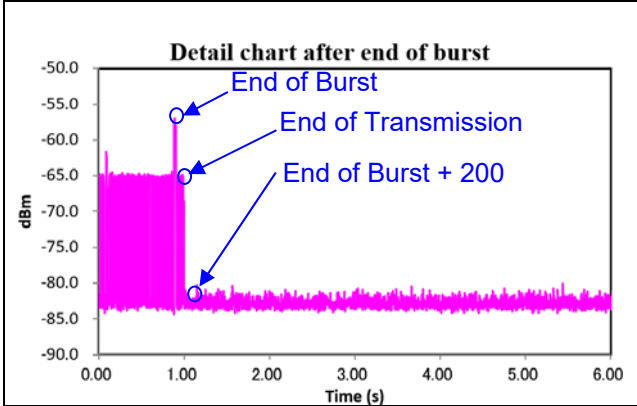

**6.4 Test result**

Test result: Pass

## **SECTION 7: Non-Occupancy Period**

### **7.1 Operating environment**

Test place	Shonan EMC Lab. No.5 Shielded Room
Date	April 27, 2023
Temperature/ Humidity	26 deg. C / 41 % RH
Engineer	Kenichi Adachi
Mode	11a

### **7.2 Test Procedure**

The following two tests are performed:

1). Transmit the data from the Master Device to the Client Device on the test Channel for the entire period of the test.

The Radar Waveform generator sends a Burst of pulses for one of the Radar Types 0-4(Master Device) or the Radar Types 0(Client Device) at levels defined on the Operating Channel. An additional 1 dB is added to the radar test signal to ensure it is at or above the DFS Detection Threshold, accounting for equipment variations/errors.

Observe the transmissions of the EUT after the Channel Move Time on the Operating Channel for duration greater than 30 minutes.

2). Transmit the data from the Master Device to the Client Device on the test Channel for the entire period of the test.

Observe the transmissions of the EUT on the Operating Channel for duration greater than 30 minutes after the Master Device is shut off.

7.3 Test data

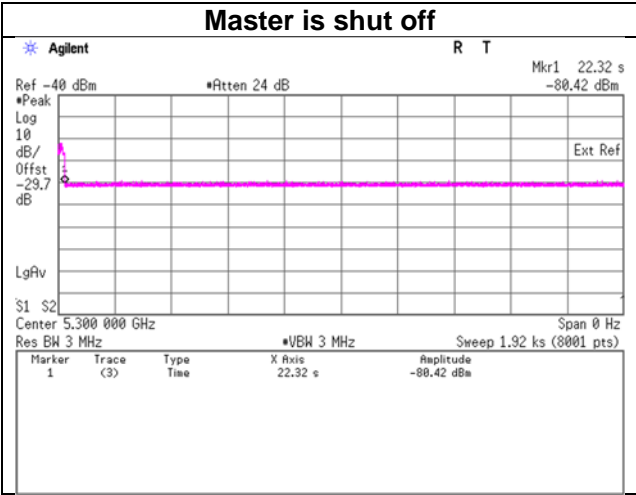
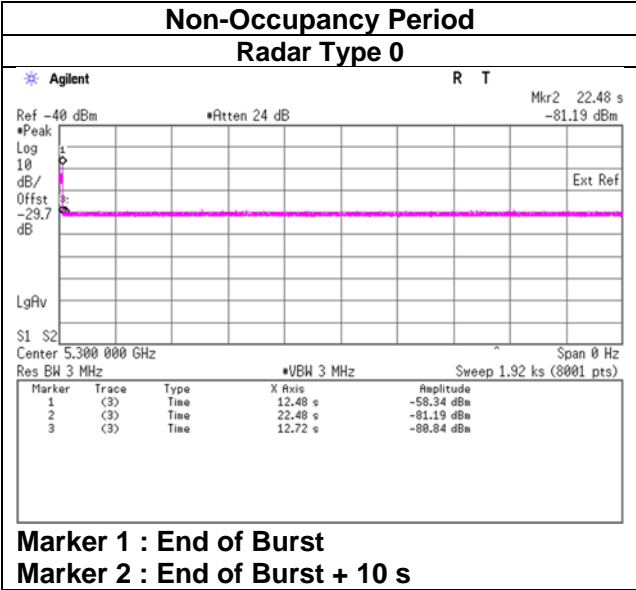

7.4 Test result

Test result: Pass

## APPENDIX 1: Test Instruments

### Test Equipment

Test Item	Local ID	LIMS ID	Description	Manufacturer	Model	Serial	Last Calibration Date	Cal Int
DFS	COTS-SDFS-03	176615	Signal Studio for DFS Rader Profiles	EMC Instruments Corporation	N7607C	-	-	-
DFS	CSG-12	143677	Signal Generator	Keysight Technologies Inc	N5182B	MY53050599	2022/06/15	12
DFS	SAT10-21	204925	Attenuator	Weinschel Corp.	54A-10	109970	2023/02/10	12
DFS	SAT10-22	204926	Attenuator	Weinschel Corp.	54A-10	109971	2023/02/10	12
DFS	SAT20-12	160495	Attenuator	Weinschel Corp.	54A-20	86752	2022/12/02	12
DFS	SAT20-13	160496	Attenuator	Weinschel Corp.	54A-20	87636	2022/12/02	12
DFS	SRE-157	145693	Wireless LAN access point	Cisco Systems, Inc.	AIR-CAP3702E-A-K9	FTX18227609	-	-
DFS	SCC-G13	145166	Coaxial Cable	Suhner	SUCOFLEX 102	31599/2	2022/12/01	12
DFS	SCC-G14	145175	Coaxial Cable	Suhner	SUCOFLEX 102	31600/2	2022/12/01	12
DFS	SCC-G25	145182	Coaxial Cable	Suhner	141PE	-	2022/07/05	12
DFS	SCC-G60	196941	Coaxial Cable	Huber+Suhner	SUCOFLEX 102	803093/2	2023/03/02	12
DFS	SOS-27	191845	Thermo-Hygrometer	CUSTOM. Inc	CTH-201	-	2022/08/08	12
DFS	SPD-01	146261	Power Divider	Keysight Technologies Inc	11636B	56998	2023/04/05	12
DFS	SPSC-14	157772	Power Splitters/Combiners	Mini-Circuits	ZFSC-2-10G-S+	-	2022/08/23	12
DFS	SPSC-15	157774	Power Splitters/Combiners	Mini-Circuits	ZFSC-2-10G-S+	-	2022/08/23	12
DFS	SSA-02	145800	Spectrum Analyzer	Keysight Technologies Inc	E4448A	MY48250106	2023/03/01	12
DFS	STS-05	146212	Digital Hitester	HIOKI E.E. CORPORATION	3805-50	80997828	2022/09/20	12

\*Hyphens for Last Calibration Date and Cal Int (month) are instruments that Calibration is not required (e.g. software), or instruments checked in advance before use.

The expiration date of the calibration is the end of the expired month.

As for some calibrations performed after the tested dates, those test equipment have been controlled by means of an unbroken chains of calibrations.

All equipment is calibrated with valid calibrations. Each measurement data is traceable to the national or international standards.

Test item:

DFS: Dynamic Frequency Selection