

APPENDIX 1 : Photographs of test setup

1. Photograph of EUT

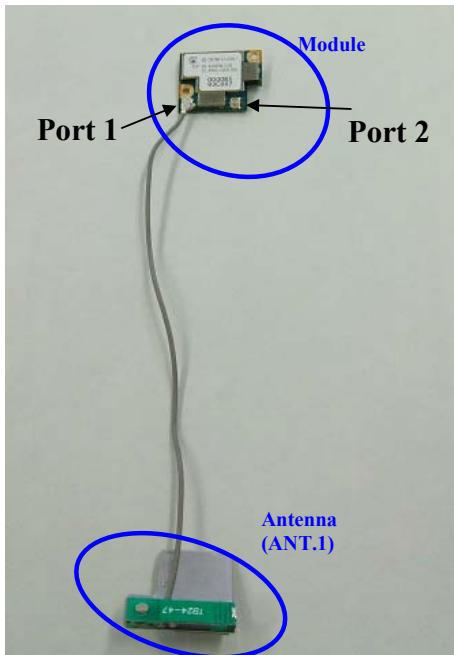

As for the transmitter (M/N: DS585762), the Ant.1 is connected with port 1 of the WLAN module unit. The antenna port2 and film antenna are not used in the transmitter (M/N: DS585762).

Photograph of Transmitter



2. Host device (Transmitter & Digital Camera)

a). Information of host device (Transmitter)

Type of Equipment	WLAN Transmitter for Digital Camera	
Model No.	DS585762	
Serial No.	No.472	
Manufacture	Canon	
Battery	Type :	Li-ion Battery
	Model Name :	LP-E6
	Rating :	DC7.2V/ 1800mAh
	Manufacturer	Canon
	Option Battery	N/A
Rating	DC8.1V(Supply from battery)	
Size of EUT	149.1(W)*45.3(H)*76.1(D) mm	
Condition of EUT	Production prototype	
The shortest distance between surface of host device and antenna	2.695 mm	

b). Information of host device (Digital Camera)

Type of Equipment	Digital SLR Camera	
Model No.	DS126201	
Serial No.	No.345	
Manufacture	Canon	
Battery	Type :	Li-ion Battery
	Model Name :	LP-E6
	Rating :	DC7.2V/ 1800mAh
	Manufacturer	Canon
	Option Battery	N/A
Size of EUT	152.2(W)*113.5(H)*74.9(D) mm	
Condition of EUT	Production prototype	

UL Japan, Inc.

Head Office EMC Lab.

4383-326 Asama-cho, Ise-shi, Mie-ken 516-0021 JAPAN

Telephone : +81 596 24 8116

Facsimile : +81 596 24 8124

3. Photograph of Host device

Right Side



Front



Rear



Bottom



4. Position of antenna

Minmum distance: 2.695mm
Between cabinet (Front surface) and antenna

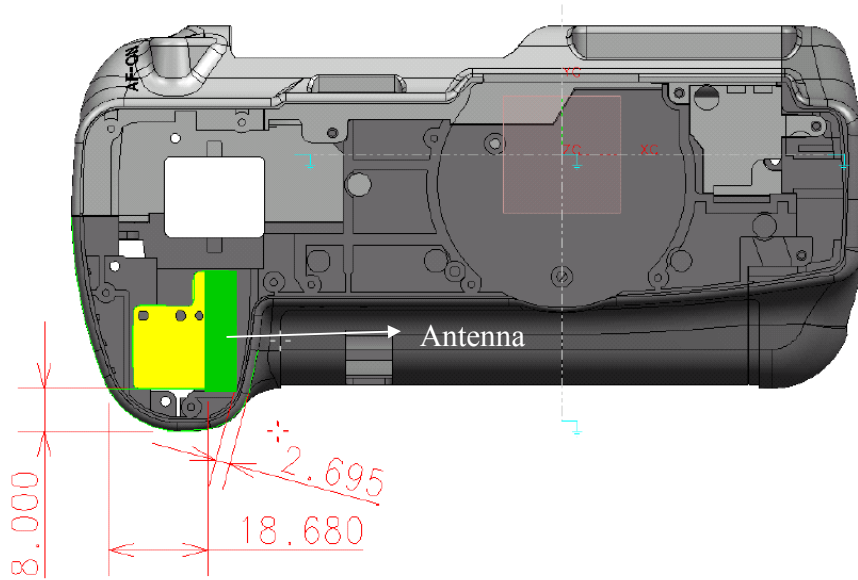

5. Photograph of test setup

(1) Front



(2) Rear



(3) Bottom



(4) Right side



(5) Front (5mm)



(6) Front (10mm)



(7) Front (15mm)

