



RADIO TEST REPORT

Test Report No. : 13707587S-A-R2

Applicant : Canon Inc.
Type of EUT : Z-Wave PCB Unit
Model Number of EUT : NCP01A
FCC ID : AZD247
Test regulation : FCC Part 15 Subpart C: 2021
Test Result : Complied (Refer to SECTION 3)

1. This test report shall not be reproduced in full or partial, without the written approval of UL Japan, Inc.
2. The results in this report apply only to the sample tested.
3. This sample tested is in compliance with the limits of the above regulation.
4. The test results in this test report are traceable to the national or international standards.
5. This test report must not be used by the customer to claim product certification, approval, or endorsement by the A2LA accreditation body.
6. This test report covers Radio technical requirements.
It does not cover administrative issues such as Manual or non-Radio test related Requirements. (if applicable)
7. The all test items in this test report are conducted by UL Japan, Inc. Shonan EMC Lab.
8. The opinions and the interpretations to the result of the description in this report are outside scopes where UL Japan has been accredited.
9. The information provided from the customer for this report is identified in SECTION 1.
10. This report is a revised version of 13707587S-A-R1. 13707587S-A-R1 is replaced with this report.

Date of test: March 20 to 22, 2021

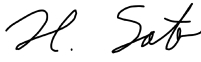
Representative test engineer: 
Hiromasa Sato
Engineer
Consumer Technology Division

Approved by: 
Toyokazu Imamura
Leader
Consumer Technology Division



CERTIFICATE 1266.03

- The testing in which "Non-accreditation" is displayed is outside the accreditation scopes in UL Japan.
 There is no testing item of "Non-accreditation".

UL Japan, Inc.
Shonan EMC Lab.

1-22-3 Megumigaoka, Hiratsuka-shi, Kanagawa-ken, 259-1220 JAPAN
Telephone : +81 463 50 6400
Facsimile : +81 463 50 6401

REVISION HISTORY

Original Test Report No.: 13707587S-A

Revision	Test report No.	Date	Page revised	Contents
- (Original)	13707587S-A	April 2, 2021	-	-
1	13707587S-A-R1	April 7, 2021	P 15	Corrected the average limit line from a solid line to a dashed line.
			P 21	Added spurious emission data of 1 GHz or less to the plot data.
2	13707587S-A-R2	April 12, 2021	P 15	Corrected the average limit line from a solid line to a dashed line.

UL Japan, Inc.

Shonan EMC Lab.

1-22-3 Megumigaoka, Hiratsuka-shi, Kanagawa-ken, 259-1220 JAPAN

Telephone : +81 463 50 6400

Facsimile : +81 463 50 6401

Reference: Abbreviations (Including words undescribed in this report)

A2LA	The American Association for Laboratory Accreditation	MCS	Modulation and Coding Scheme
AC	Alternating Current	MRA	Mutual Recognition Arrangement
AFH	Adaptive Frequency Hopping	N/A	Not Applicable
AM	Amplitude Modulation	NIST	National Institute of Standards and Technology
Amp, AMP	Amplifier	NS	No signal detect.
ANSI	American National Standards Institute	NSA	Normalized Site Attenuation
Ant, ANT	Antenna	NVLAP	National Voluntary Laboratory Accreditation Program
AP	Access Point	OBW	Occupied Band Width
ASK	Amplitude Shift Keying	OFDM	Orthogonal Frequency Division Multiplexing
Atten., ATT	Attenuator	P/M	Power meter
AV	Average	PCB	Printed Circuit Board
BPSK	Binary Phase-Shift Keying	PER	Packet Error Rate
BR	Bluetooth Basic Rate	PHY	Physical Layer
BT	Bluetooth	PK	Peak
BT LE	Bluetooth Low Energy	PN	Pseudo random Noise
BW	BandWidth	PRBS	Pseudo-Random Bit Sequence
Cal Int	Calibration Interval	PSD	Power Spectral Density
CCK	Complementary Code Keying	QAM	Quadrature Amplitude Modulation
Ch., CH	Channel	QP	Quasi-Peak
CISPR	Comite International Special des Perturbations Radioelectriques	QPSK	Quadri-Phase Shift Keying
CW	Continuous Wave	RBW	Resolution Band Width
DBPSK	Differential BPSK	RDS	Radio Data System
DC	Direct Current	RE	Radio Equipment
D-factor	Distance factor	RF	Radio Frequency
DFS	Dynamic Frequency Selection	RMS	Root Mean Square
DQPSK	Differential QPSK	RSS	Radio Standards Specifications
DSSS	Direct Sequence Spread Spectrum	Rx	Receiving
EDR	Enhanced Data Rate	SA, S/A	Spectrum Analyzer
EIRP, e.i.r.p.	Equivalent Isotropically Radiated Power	SG	Signal Generator
EMC	ElectroMagnetic Compatibility	SVSWR	Site-Voltage Standing Wave Ratio
EMI	ElectroMagnetic Interference	TR	Test Receiver
EN	European Norm	Tx	Transmitting
ERP, e.r.p.	Effective Radiated Power	VBW	Video BandWidth
EU	European Union	Vert.	Vertical
EUT	Equipment Under Test	WLAN	Wireless LAN
Fac.	Factor		
FCC	Federal Communications Commission		
FHSS	Frequency Hopping Spread Spectrum		
FM	Frequency Modulation		
Freq.	Frequency		
FSK	Frequency Shift Keying		
GFSK	Gaussian Frequency-Shift Keying		
GNSS	Global Navigation Satellite System		
GPS	Global Positioning System		
Hori.	Horizontal		
ICES	Interference-Causing Equipment Standard		
IEC	International Electrotechnical Commission		
IEEE	Institute of Electrical and Electronics Engineers		
IF	Intermediate Frequency		
ILAC	International Laboratory Accreditation Conference		
ISED	Innovation, Science and Economic Development Canada		
ISO	International Organization for Standardization		
JAB	Japan Accreditation Board		
LAN	Local Area Network		
LIMS	Laboratory Information Management System		

UL Japan, Inc.

Shonan EMC Lab.

1-22-3 Megumigaoka, Hiratsuka-shi, Kanagawa-ken, 259-1220 JAPAN

Telephone : +81 463 50 6400

Facsimile : +81 463 50 6401

CONTENTS	PAGE
SECTION 1: Customer information.....	5
SECTION 2: Equipment under test (EUT).....	5
SECTION 3: Test specification, procedures & results.....	6
SECTION 4: Operation of EUT during testing.....	9
SECTION 5: Conducted Emission.....	10
SECTION 6: Radiated Spurious Emission	11
SECTION 7: Bandwidth and Duty Cycle.....	13
APPENDIX 1: Test data	14
Conducted Emission	14
Duty Cycle	16
20 dB Bandwidth and 99 % Occupied Bandwidth.....	17
Radiated Spurious Emission	18
APPENDIX 2: Test instruments	22
APPENDIX 3: Photographs of test setup	24
Conducted Emission	24
Radiated Spurious Emission	25
Pre-Check Worst Case Position	26
Antenna Terminal Conducted Tests.....	27

SECTION 1: Customer information

Company Name : Canon Inc.
Address : 16-1, Shimonoge 3-chome, Takatsu-ku, Kawasaki-shi, Kanagawa 213-8512, Japan
Telephone Number : +81-44-330-6818
Facsimile Number : +81-44-844-3938
Contact Person : Yoshihiro Funamizu

The information provided from the customer is as follows;

- Applicant, Type of EUT, Model Number of EUT, FCC ID on the cover and other relevant pages
- Operating/Test Mode(s) (Mode(s)) on all the relevant pages
- SECTION 1: Customer information
- SECTION 2: Equipment under test (EUT) other than the Receipt Date
- SECTION 4: Operation of EUT during testing

* The laboratory is exempted from liability of any test results affected from the above information in SECTION 2 and 4.

SECTION 2: Equipment under test (EUT)

2.1 Identification of EUT

Type : Z-Wave PCB Unit
Model Number : NCP01A
Serial Number : Refer to SECTION 4.2
Rating : DC 3.3 V
Receipt Date : February 10, 2021
Country of Mass-production : Taiwan
Condition : Production prototype
(Not for Sale: This sample is equivalent to mass-produced items.)
Modification : No Modification by the test lab.

2.2 Product Description

Model: NCP01A (referred to as the EUT in this report) is Z-Wave PCB Unit.

Radio Specification

Radio Type : Transceiver
Frequency of Operation : 908.4 MHz - 916 MHz
Modulation : GFSK
Antenna type : Monopole
Antenna Gain : -0.9 dBi
Clock frequency (Maximum) : 39 MHz

SECTION 3: Test specification, procedures & results

3.1 Test Specification

Test Specification : FCC Part 15 Subpart C
FCC Part 15 final revised on January 12, 2021 and effective February 11, 2021

Title : FCC 47CFR Part15 Radio Frequency Device Subpart C Intentional Radiators
Section 15.207 Conducted limits
Section 15.249 Operation within the bands 902-928 MHz, 2400-2483.5 MHz,
5725-5875 MHz, and 24.0-24.25 GHz.

3.2 Procedures and results

Item	Test Procedure	Specification	Worst margin	Results	Remarks
Conducted emission	FCC: ANSI C63.10:2013 ISED: RSS-Gen 8.8	FCC 15.207(a) ISED: RSS-Gen 8.8	38.9 dB (18.07707 MHz, N, AV, Tx 908.4 MHz)	Complied a)	*1)
Electric field strength of fundamental emission	FCC: ANSI C63.10:2013 ISED: RSS-Gen 6.6, 6.12	FCC 15.249(a)(e) ISED: RSS-210 B.10	3.3 dB (916.000 MHz, Horizontal, QP, Tx 916 MHz)	Complied# b)	-
Electric field strength of spurious emission	FCC: ANSI C63.10:2013 ISED: RSS-Gen 6.5,6.6, 6.13	FCC 15.205(a)(b) FCC 15.209(a) FCC 15.249(a)(d)(e) ISED: RSS-210 B.10	4.4 dB (3633.600 MHz, Horizontal, AV, Tx 908.4 MHz)	Complied# b)	-
20 dB bandwidth	FCC: ANSI C63.10:2013 ISED: -	FCC 15.215 ISED: -	-	Complied c)	-
Frequency tolerance	FCC: ANSI C63.10:2013 ISED: RSS-Gen 6.11, 8.11	FCC 15.249(b) ISED: -	-	-	*1)

Note: UL Japan's Work Procedures No. 13-EM-W0420 and 13-EM-W0422

*1) The test is not required since this EUT does not operate with 24.05 GHz to 24.25 GHz.

a) Refer to APPENDIX 1 (data of Conducted Emission)

b) Refer to APPENDIX 1 (data of Radiated Emission)

c) Refer to APPENDIX 1 (data of 20dB Bandwidth, 99% Occupied Bandwidth)

Symbols:

Complied The data of this test item has enough margin, more than the measurement uncertainty.

Complied# The data of this test item meets the limits unless the measurement uncertainty is taken into consideration.

* In case any questions arise about test procedure, ANSI C63.10: 2013 is also referred.

FCC Part 15.31 (e)

This EUT is provided the stable voltage constantly from the host device. Therefore, this EUT complies with the requirement.

FCC Part 15.203 Antenna requirement

It is impossible for end users to replace the antenna, because the antenna is mounted inside of the EUT. Therefore, the equipment complies with the antenna requirement of Section 15.203.

UL Japan, Inc.

Shonan EMC Lab.

1-22-3 Megumigaoka, Hiratsuka-shi, Kanagawa-ken, 259-1220 JAPAN

Telephone : +81 463 50 6400

Facsimile : +81 463 50 6401

3.3 Addition to standard

Item	Test Procedure	Specification	Worst margin	Results	Remarks
99% Occupied Bandwidth	ISED: RSS-Gen 6.7	ISED: -	N/A	- a)	Conducted
a) Refer to APPENDIX 1 (data of 20 dB Bandwidth and 99 % Occupied Bandwidth)					

Other than above, no addition, exclusion nor deviation has been made from the standard.

3.4 Uncertainty

There is no applicable rule of uncertainty in this applied standard. Therefore, the results are derived depending on whether or not laboratory uncertainty is applied.

The following uncertainties have been calculated to provide a confidence level of 95 % using a coverage factor $k=2$.

Shonan EMC Lab.

Item	Frequency range	Uncertainty (+/-)			
		No. 1 SAC / SR	No. 2 SAC / SR	No. 3 SAC / SR	No. 4,5,6,8 SR
Conducted emission (AC Mains) LISN	150 kHz-30 MHz	2.6 dB	2.6 dB	2.56dB	2.9 dB
Radiated emission (Measurement distance: 3 m)	9 kHz-30 MHz	3.0 dB	2.7 dB	2.7 dB	-
	30 MHz-200 MHz	4.6 dB	4.6 dB	4.6 dB	-
	200 MHz-1 GHz	6.0 dB	6.0 dB	6.0 dB	-
	1 GHz-6 GHz	4.8 dB	4.8 dB	4.8 dB	-
	6 GHz-18 GHz	5.4 dB	5.4 dB	5.4 dB	-
	18 GHz-40 GHz	5.3 dB	5.3 dB	5.3 dB	-
Radiated emission (Measurement distance: 1 m)	1 GHz-18 GHz	5.7 dB	5.7 dB	5.7 dB	-
	18 GHz-40 GHz	5.6 dB	5.6 dB	5.6 dB	-

SAC=Semi-Anechoic Chamber

SR= Shielded Room is applied besides radiated emission

Antenna terminal test	Uncertainty (+/-)
Power Measurement above 1 GHz (Average Detector)_SPM-06	1.4 dB
Power Measurement above 1 GHz (Peak Detector)_SPM-06	1.6 dB
Power Measurement above 1 GHz (Average Detector)_SPM-07	0.89 dB
Power Measurement above 1 GHz (Peak Detector)_SPM-07	1.2 dB
Power Measurement above 1 GHz (Average Detector)_SPM-13	0.91 dB
Power Measurement above 1 GHz (Peak Detector)_SPM-13	1.2 dB
Spurious emission (Conducted) below 1GHz	0.87 dB
Spurious emission (Conducted) 1 GHz-3 GHz	0.96 dB
Spurious emission (Conducted) 3 GHz-18 GHz	3.0 dB
Spurious emission (Conducted) 18 GHz-26.5 GHz	2.6 dB
Spurious emission (Conducted) 26.5 GHz-40 GHz	2.2 dB
Bandwidth Measurement	0.012 %
Duty cycle and Time Measurement	0.27 %
Temperature_SCH-01	0.95 deg.C.
Humidity_SCH-01	0.83 %
Temperature_SCH-02	2.0 deg.C.
Humidity_SCH-02	6.6 %
Voltage	0.86 %

UL Japan, Inc.

Shonan EMC Lab.

1-22-3 Megumigaoka, Hiratsuka-shi, Kanagawa-ken, 259-1220 JAPAN

Telephone : +81 463 50 6400

Facsimile : +81 463 50 6401

3.5 Test Location

UL Japan, Inc. Shonan EMC Lab.

1-22-3, Megumigaoka, Hiratsuka-shi, Kanagawa-ken 259-1220 JAPAN

Telephone: +81 463 50 6400, Facsimile: +81 463 50 6401

A2LA Certificate Number: 1266.03

(FCC test firm registration number: 626366, ISED lab company number: 2973D / CAB identifier: JP0001)

Test site	IC Registration Number	Width x Depth x Height (m)	Size of reference ground plane (m) / horizontal conducting plane	Maximum measurement distance
No.1 Semi-anechoic chamber	2973D-1	20.6 x 11.3 x 7.65	20.6 x 11.3	10 m
No.2 Semi-anechoic chamber	2973D-2	20.6 x 11.3 x 7.65	20.6 x 11.3	10 m
No.3 Semi-anechoic chamber	2973D-3	12.7 x 7.7 x 5.35	12.7 x 7.7	5 m
No.4 Semi-anechoic chamber	-	8.1 x 5.1 x 3.55	8.1 x 5.1	-
No.1 Shielded room	-	6.8 x 4.1 x 2.7	6.8 x 4.1	-
No.2 Shielded room	-	6.8 x 4.1 x 2.7	6.8 x 4.1	-
No.3 Shielded room	-	6.3 x 4.7 x 2.7	6.3 x 4.7	-
No.4 Shielded room	-	4.4 x 4.7 x 2.7	4.4 x 4.7	-
No.5 Shielded room	-	7.8 x 6.4 x 2.7	7.8 x 6.4	-
No.6 Shielded room	-	7.8 x 6.4 x 2.7	7.8 x 6.4	-
No.8 Shielded room	-	3.45 x 5.5 x 2.4	3.45 x 5.5	-
No.1 Measurement room	-	2.55 x 4.1 x 2.5	-	-

3.6 Test data, Test instruments, and Test set up

Refer to APPENDIX.

SECTION 4: Operation of EUT during testing

4.1 Operating Mode(s)

Test Item	Mode	Tested frequency
Electric Field Strength of Fundamental Emission Electric Field Strength of Spurious Emission Bandwidth Duty cycle	Transmitting	908.4 MHz, 908.42 MHz, 916 MHz
<p>The system was configured in typical fashion (as a customer would normally use it) for testing.</p> <p>*EUT has the power settings by the software as follows; - Power Setting: 13 dBm - Software: Tera Term Ver.4.96</p> <p>*This setting of software is the worst case. Any conditions under the normal use do not exceed the condition of setting.</p>		

4.2 Configuration and peripherals

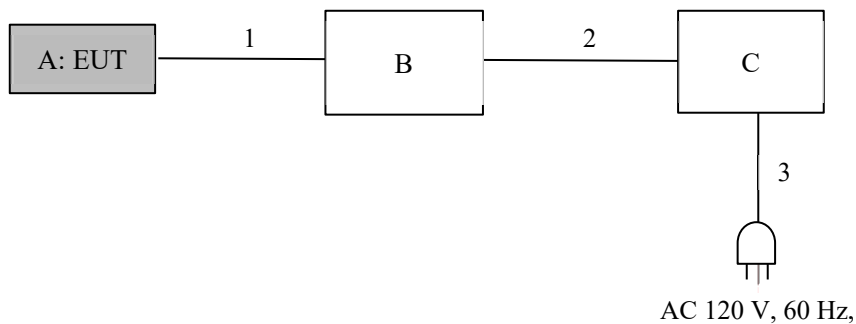

* Cabling and setup(s) were taken into consideration and test data was taken under worse case conditions.

Description of EUT and Support equipment

No.	Item	Model number	Serial number	Manufacturer	Remarks
A	Z-Wave PCB Unit	NCP01A	30	Canon	EUT
B	Jig Board	PCB4001 Rev A03	190750418	SILICON LABS	-
C	Power Supply (DC)	PAN60-10A	NL002383	KIKUSUI	-

List of cables used

No.	Name	Length (m)	Shield		Remarks
			Cable	Connector	
1	Signal Cable	0.15	Unshielded	Unshielded	-
2	DC	0.07 + 1.9	Unshielded	Unshielded	-
3	AC	3.0	Unshielded	Unshielded	-

UL Japan, Inc.

Shonan EMC Lab.

1-22-3 Megumigaoka, Hiratsuka-shi, Kanagawa-ken, 259-1220 JAPAN

Telephone : +81 463 50 6400

Facsimile : +81 463 50 6401

SECTION 5: Conducted Emission

Test Procedure and conditions

EUT was placed on a wooden table of nominal size, 0.8 m by 1.6 m, raised 0.8 m above the conducting ground plane. The rear of tabletop was located 40 cm to the vertical conducting plane. The rear of EUT, including peripherals aligned and flushed with rear of tabletop. All other surfaces of tabletop were at least 80cm from any other grounded conducting surface. EUT was located 80 cm from a Line Impedance Stabilization Network (LISN) / Artificial mains Network (AMN) and excess AC cable was bundled in center.

For the tests on EUT with other peripherals (as a whole system)

I/O cables that were connected to the peripherals were bundled in center. They were folded back and forth forming a bundle 30 cm to 40 cm long and were hanged at a 40 cm height to the ground plane.

The AC Mains Terminal Continuous disturbance Voltage has been measured with the EUT in a Semi Anechoic Chamber. The EUT was connected to a LISN (AMN).

An overview sweep with peak detection has been performed.

The test results and limit are rounded off to one decimal place, so some differences might be observed.

Detector	: QP and CISPR AV
Measurement range	: 0.15 MHz - 30 MHz
Test data	: APPENDIX
Test result	: Pass

Figure 1. Test Setup

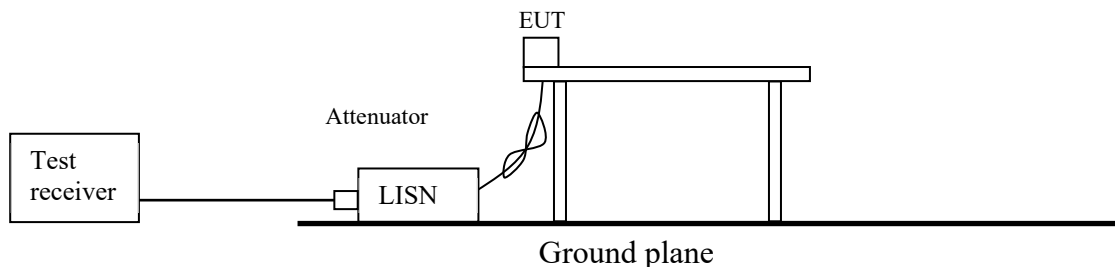

SECTION 6: Radiated Spurious Emission

Test Procedure

[For below 1 GHz]

EUT was placed on a urethane platform of nominal size, 0.5 m by 0.5 m, raised 0.8 m above the conducting ground plane. The Radiated Electric Field Strength has been measured in a Semi Anechoic Chamber with a ground plane.

[For above 1 GHz]

EUT was placed on a urethane platform of nominal size, 0.5 m by 0.5 m, raised 1.5 m above the conducting ground plane. The Radiated Electric Field Strength has been measured in a Semi Anechoic Chamber with absorbent materials lined on a ground plane.

Although these tests were performed other than open area test site, adequate comparison measurements were confirmed against 30 m open area test site. Therefore sufficient tests were made to demonstrate that the alternative site produces results that correlate with the ones of tests made in an open field based on KDB 414788. These tests were performed in semi anechoic chamber. Therefore the measured level of emissions may be higher than if measurements were made without a ground plane. However test results were confirmed to pass against standard limit.

Frequency: From 9 kHz to 30 MHz at distance 3 m (Refer to Figure 2)

The EUT was rotated a full revolution in order to obtain the maximum value of the electric field intensity.

The measurements were performed for vertical polarization (antenna angle: 0 deg., 45 deg., 90 deg. and 135 deg.) and horizontal polarization. Drawing of the antenna direction is shown in Figure 1.

Frequency: From 30 MHz to 26.5 GHz at distance 3 m (Refer to Figure 2).

The measuring antenna height was varied between 1 m and 4 m and EUT was rotated a full revolution in order to obtain the maximum value of the electric field intensity.

The measurements were performed for both vertical and horizontal antenna polarization.

Measurements were performed with QP, PK, and AV detector.

Test Antennas are used as below;

Frequency	Below 30 MHz	30 MHz to 200 MHz	200 MHz to 1 GHz	Above 1 GHz
Antenna Type	Loop	Biconical	Logperiodic	Horn

	9 kHz to 90 kHz & 110 kHz to 150 kHz	90 kHz to 110 kHz	150 kHz to 490 kHz	490 kHz to 30 MHz	30 MHz to 1 GHz
Detector Type	PK/AV	QP	PK/AV	QP	QP
IF Bandwidth	200 Hz	200 Hz	10 kHz	9 kHz	120 kHz
Distance factor *1)	-80 dB	-80 dB	-80 dB	-40 dB	-

*1) FCC 15.31 (f)(2) (9kHz-30MHz)

Distance Factor: $40 \times \log(3 \text{ m} / 300 \text{ m}) = -80 \text{ dB}$

Distance Factor: $40 \times \log(3 \text{ m} / 30 \text{ m}) = -40 \text{ dB}$

	above 1 GHz	
Detector Type	PK	AV *2)
IF Bandwidth	RBW: 1 MHz VBW: 3 MHz	Reduced VBW Method <u>11.12.2.5.3</u> RBW: 1 MHz VBW: 10 Hz Detector: Peak Trace: max hold

*2) Average Power Measurement was performed based on ANSI C63.10-2013.

UL Japan, Inc.

Shonan EMC Lab.

1-22-3 Megumigaoka, Hiratsuka-shi, Kanagawa-ken, 259-1220 JAPAN

Telephone : +81 463 50 6400

Facsimile : +81 463 50 6401

Figure 2. Direction of the Loop Antenna

Side View (Vertical)

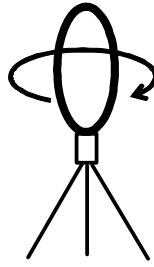
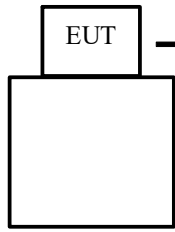

Front side: 0 deg.
 Forward direction: clockwise

Top View (Vertical)

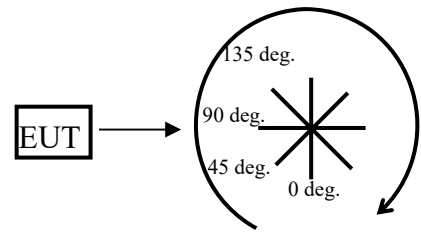

Front side: 0 deg.
 Forward direction: clockwise

Top View (Horizontal)

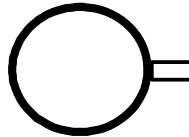
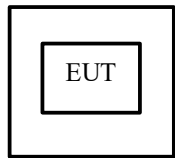

Antenna was not rotated.

Figure 3. Test Setup

Below 1 GHz

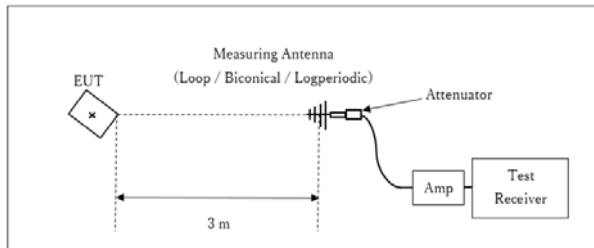

* : Center of turn table

Test Distance: 3 m

1 GHz - 10 GHz

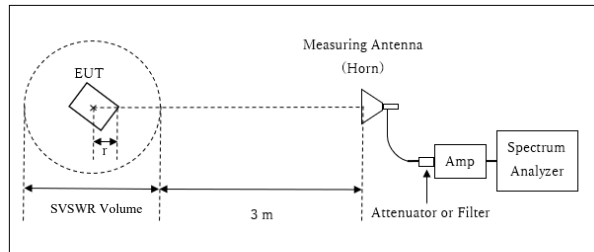

r : Radius of an outer periphery of EUT
 * : Center of turn table

Distance Factor: $20 \times \log(3.98 \text{ m} / 3.0 \text{ m}) = 2.46 \text{ dB}$

* Test Distance: $(3 + \text{SVSWR Volume} / 2) - r = 3.98 \text{ m}$

SVSWR Volume : 2.0 m

(SVSWR Volume has been calibrated based on CISPR 16-1-4.)

$r = 0.02 \text{ m}$

- The carrier level and noise levels were confirmed at each position of X, Y and Z axes of EUT to see the position of maximum noise, and the test was made at the position that has the maximum noise.

Antenna polarization	Carrier	Spurious (Below 1 GHz)	Spurious (1 GHz -10 GHz)
Horizontal	Y	X	X
Vertical	Z	X	Y

The test results and limit are rounded off to one decimal place, so some differences might be observed.

Measurement range : 30 MHz - 10 GHz
Test data : APPENDIX
Test result : Pass

SECTION 7: Bandwidth and Duty Cycle

Test Procedure

Test	Span	RBW	VBW	Sweep	Detector	Trace	Instrument used
Duty Cycle	zero span	8 MHz	50 MHz	100 msec	Peak	Single	Spectrum Analyzer
20 dB Bandwidth	2 to 5 time of OBW.	1 to 5 % of OBW	Three times of RBW	Auto	Peak	Max Hold	Spectrum Analyzer
99 % Occupied Bandwidth	Enough width to display emission skirts	1 to 5 % of OBW	Three times of RBW	Auto	Peak	Max Hold *1)	Spectrum Analyzer

*1) Peak hold was applied as Worst-case measurement.

Test data : APPENDIX 1
Test result : Pass

APPENDIX 1: Test data

Conducted Emission

DATA OF CONDUCTED EMISSION TEST

UL Japan, Inc. Shonan EMC Lab. No.6 Shielded Room
Date : 2021/03/22

Mode : Tx 908.4 MHz
Power : AC 120 V / 60 Hz
Temp./Humi. : 21 deg.C / 45 %RH

Remarks : -

Limit : FCC_Part 15 Subpart C(15.207)

Engineer : Toshinori Yamada

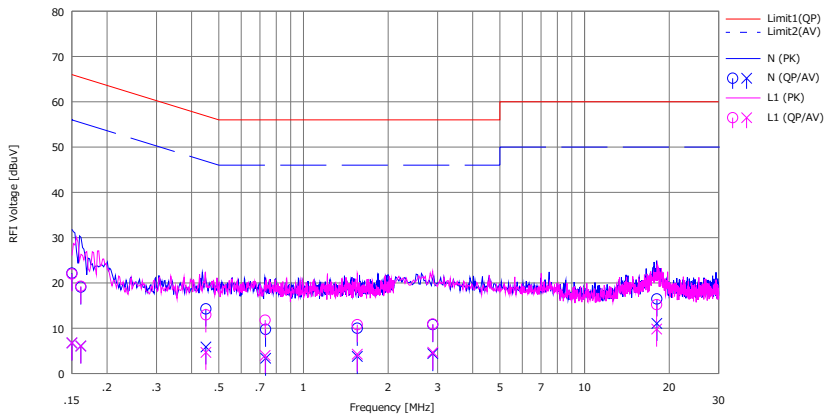

No.	Freq. [MHz]	Reading		C.Fac	Results		Limit		Margin		Phase	Comment
		(QP) [dBuV]	(AV) [dBuV]		(QP) [dBuV]	(AV) [dBuV]	(QP) [dB]	(AV) [dB]	(QP) [dB]	(AV) [dB]		
1	0.15000	9.80	-5.60	12.37	22.17	6.77	66.00	56.00	43.8	49.2	N	
2	0.16146	6.70	-6.30	12.38	19.08	6.08	65.39	55.39	46.3	49.3	N	
3	0.44973	1.90	-6.50	12.37	14.27	5.87	56.88	46.88	42.6	41.0	N	
4	0.73340	-2.60	-9.00	12.37	9.77	3.37	56.00	46.00	46.2	42.6	N	
5	1.55423	-2.40	-8.60	12.39	9.99	3.79	56.00	46.00	46.0	42.2	N	
6	2.88391	-1.60	-8.00	12.41	10.81	4.41	56.00	46.00	45.1	41.5	N	
7	18.07707	3.50	-1.90	12.98	16.48	11.08	60.00	50.00	43.5	38.9	N	
8	0.15000	9.60	-5.60	12.39	21.99	6.79	66.00	56.00	44.0	49.2	L1	
9	0.16142	6.90	-6.30	12.38	19.28	6.08	65.39	55.39	46.1	49.3	L1	
10	0.44960	0.60	-7.70	12.37	12.97	4.67	56.88	46.88	43.9	42.2	L1	
11	0.73095	-0.60	-8.40	12.39	11.79	3.99	56.00	46.00	44.2	42.0	L1	
12	1.55413	-1.60	-8.10	12.39	10.79	4.29	56.00	46.00	45.2	41.7	L1	
13	2.88305	-1.50	-7.70	12.42	10.92	4.72	56.00	46.00	45.0	41.2	L1	
14	18.05217	2.50	-2.90	12.72	15.22	9.82	60.00	50.00	44.7	40.1	L1	

Calculation: Result[dBuV]=Reading[dBuV]+C.Fac(LISN(AMN)+Cable+ATT)[dB]
LISN(AMN):SLS-03

Conducted Emission

Report No.	13707587S-A-R2
Test place	Shonan EMC Lab. No.6 Shielded Room
Date	March 22, 2021
Temperature / Humidity	21 deg. C / 45 % RH
Engineer	Toshinori Yamada
Mode	Tx

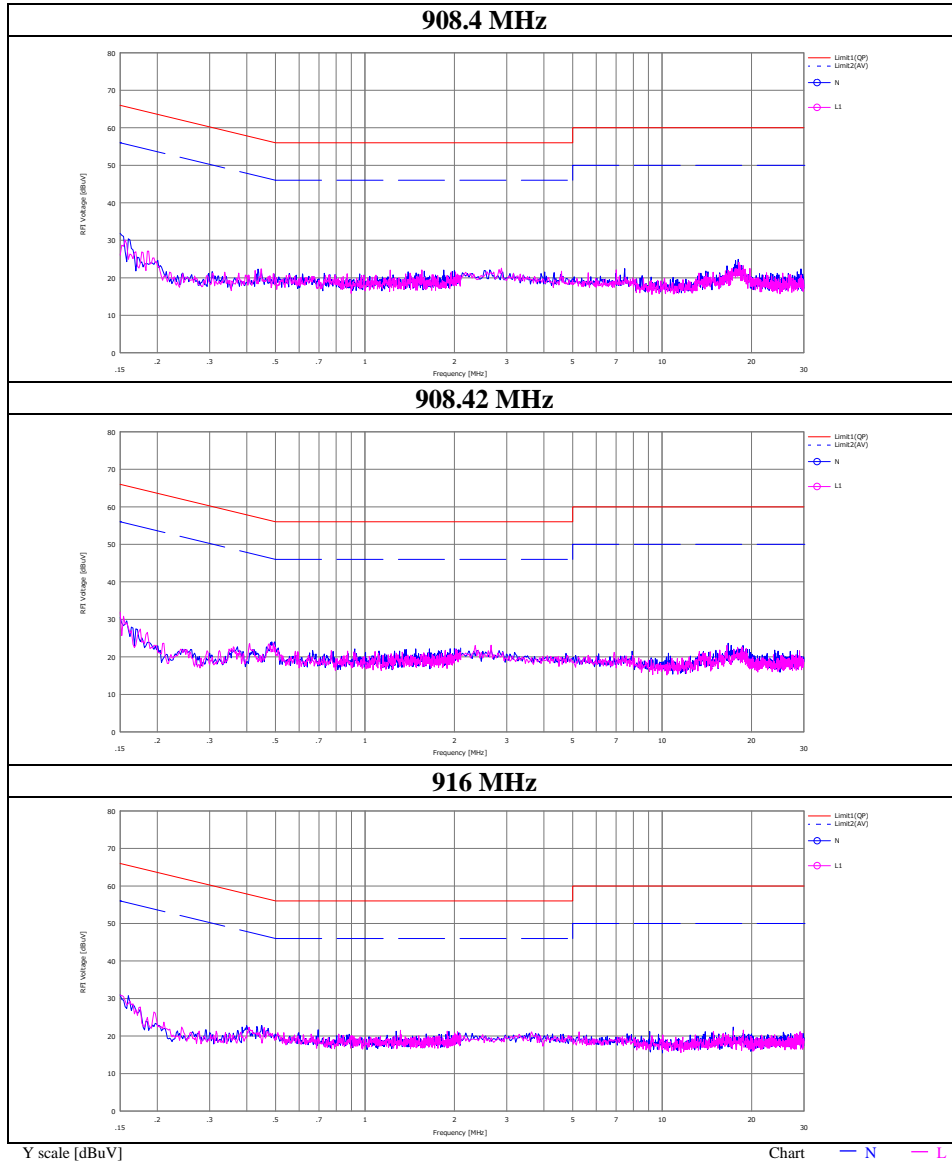

UL Japan, Inc.

Shonan EMC Lab.

1-22-3 Megumigaoka, Hiratsuka-shi, Kanagawa-ken, 259-1220 JAPAN

Telephone : +81 463 50 6400

Facsimile : +81 463 50 6401

Duty Cycle

Report No. 13707587S-A-R2
 Test place Shonan EMC Lab. No.6 Shielded Room
 Date March 22, 2021
 Temperature / Humidity 21 deg. C / 45 % RH
 Engineer Toshinori Yamada
 Mode Tx 908.42 MHz

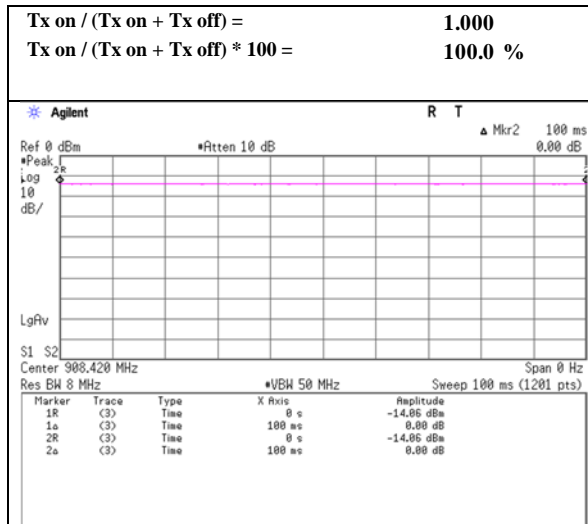

20 dB Bandwidth and 99 % Occupied Bandwidth

Report No.	13707587S-A-R2
Test place	Shonan EMC Lab. No.6 Shielded Room
Date	March 22, 2021
Temperature / Humidity	21 deg. C / 45 % RH
Engineer	Toshinori Yamada
Mode	Tx 908.42 MHz

Freq. [MHz]	20dB Bandwidth [MHz]	99% Occupied Bandwidth [kHz]
908.40	91.488	92.522
908.42	98.999	94.334
916.00	123.583	113.872

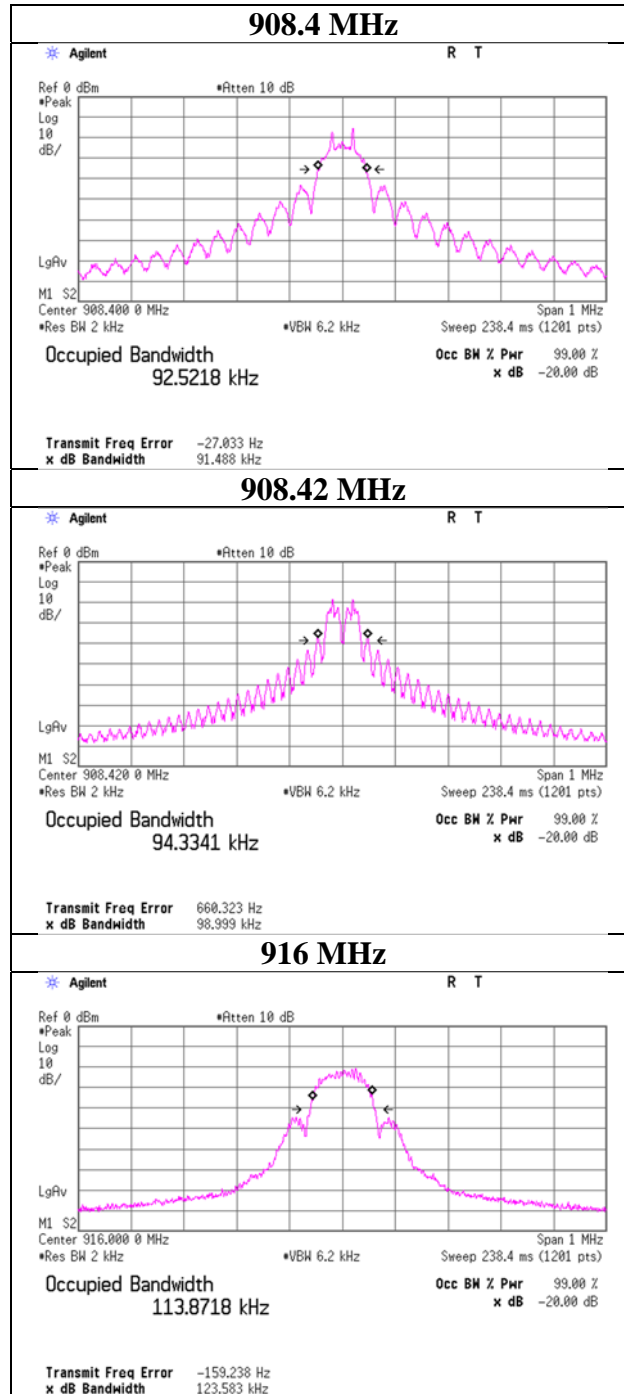

Radiated Spurious Emission

Report No. 13707587S-A-R2
Test place Shonan EMC Lab.
Semi Anechoic Chamber No.2
Date March 20, 2021
Temperature / Humidity 22 deg. C / 41 % RH
Engineer Hiromasa Sato
Mode Tx 908.4 MHz

(* PK: Peak, AV: Average, QP: Quasi-Peak)

Polarity	Frequency [MHz]	Detector	Reading [dBuV]	Ant. Fac. [dB/m]	Loss [dB]	Gain [dB]	Distance Factor [dB]	Result [dBuV/m]	Limit [dBuV/m]	Margin [dB]	Height [cm]	Angle [deg]	Remark
Hori.	902.000	QP	20.87	22.12	9.48	30.84	0.00	21.63	46.0	24.3	100	275	-
Hori.	908.400	QP	88.21	22.15	9.51	30.80	0.00	89.07	93.9	4.8	100	275	Carrier
Hori.	1816.800	PK	45.62	25.81	4.51	38.96	2.46	39.44	73.9	34.4	120	112	-
Hori.	2725.200	PK	44.43	28.43	5.04	38.53	2.46	41.83	73.9	32.0	201	181	-
Hori.	3633.600	PK	52.74	29.76	5.74	38.16	2.46	52.54	73.9	21.3	151	132	-
Hori.	4542.000	PK	43.90	31.06	6.35	38.55	2.46	45.22	73.9	28.6	150	0	-
Hori.	5450.400	PK	48.24	32.47	7.06	38.80	2.46	51.43	73.9	22.4	164	146	-
Hori.	6358.800	PK	44.64	34.34	7.66	39.01	2.46	50.09	73.9	23.8	150	0	-
Hori.	7267.200	PK	45.45	37.66	8.08	39.21	2.46	54.44	73.9	19.4	150	0	-
Hori.	8175.600	PK	44.57	37.85	8.45	39.37	2.46	53.96	73.9	19.9	150	0	-
Hori.	9084.000	PK	45.77	38.06	9.21	39.70	2.46	55.80	73.9	18.1	150	0	-
Hori.	1816.800	AV	33.49	25.81	4.51	38.96	2.46	27.31	53.9	26.5	120	112	VBW:10 Hz
Hori.	2725.200	AV	33.58	28.43	5.04	38.53	2.46	30.98	53.9	22.9	201	181	VBW:10 Hz
Hori.	3633.600	AV	49.69	29.76	5.74	38.16	2.46	49.49	53.9	4.4	151	132	VBW:10 Hz
Hori.	4542.000	AV	32.34	31.06	6.35	38.55	2.46	33.66	53.9	20.2	150	0	VBW:10 Hz
Hori.	5450.400	AV	40.97	32.47	7.06	38.80	2.46	44.16	53.9	9.7	164	146	VBW:10 Hz
Hori.	6358.800	AV	33.27	34.34	7.66	39.01	2.46	38.72	53.9	15.1	150	0	VBW:10 Hz
Hori.	7267.200	AV	33.21	37.66	8.08	39.21	2.46	42.20	53.9	11.7	150	0	VBW:10 Hz
Hori.	8175.600	AV	33.58	37.85	8.45	39.37	2.46	42.97	53.9	10.9	150	0	VBW:10 Hz
Hori.	9084.000	AV	33.60	38.06	9.21	39.70	2.46	43.63	53.9	10.2	150	0	VBW:10 Hz
Vert.	902.000	QP	20.34	22.12	9.48	30.84	0.00	21.10	46.0	24.9	131	179	VBW:10 Hz
Vert.	908.400	QP	86.05	22.15	9.51	30.80	0.00	86.91	93.9	6.9	131	179	-
Vert.	1816.800	PK	45.08	25.81	4.51	38.96	2.46	38.90	73.9	35.0	116	200	Carrier
Vert.	2725.200	PK	45.25	28.43	5.04	38.53	2.46	42.65	73.9	31.2	142	274	-
Vert.	3633.600	PK	50.99	29.76	5.74	38.16	2.46	50.79	73.9	23.1	282	245	-
Vert.	4542.000	PK	43.74	31.06	6.35	38.55	2.46	45.06	73.9	28.8	150	0	-
Vert.	5450.400	PK	47.11	32.47	7.06	38.80	2.46	50.30	73.9	23.6	109	273	-
Vert.	6358.800	PK	45.13	34.34	7.66	39.01	2.46	50.58	73.9	23.3	150	0	-
Vert.	7267.200	PK	45.04	37.66	8.08	39.21	2.46	54.03	73.9	19.8	150	0	-
Vert.	8175.600	PK	45.67	37.85	8.45	39.37	2.46	55.06	73.9	18.8	150	0	-
Vert.	9084.000	PK	45.41	38.06	9.21	39.70	2.46	55.44	73.9	18.4	150	0	-
Vert.	1816.800	AV	33.17	25.81	4.51	38.96	2.46	26.99	53.9	26.9	116	200	VBW:10 Hz
Vert.	2725.200	AV	32.84	28.43	5.04	38.53	2.46	30.24	53.9	23.6	142	274	VBW:10 Hz
Vert.	3633.600	AV	47.07	29.76	5.74	38.16	2.46	46.87	53.9	7.0	282	245	VBW:10 Hz
Vert.	4542.000	AV	32.85	31.06	6.35	38.55	2.46	34.17	53.9	19.7	150	0	VBW:10 Hz
Vert.	5450.400	AV	38.70	32.47	7.06	38.80	2.46	41.89	53.9	12.0	109	273	VBW:10 Hz
Vert.	6358.800	AV	33.65	34.34	7.66	39.01	2.46	39.10	53.9	14.8	150	0	VBW:10 Hz
Vert.	7267.200	AV	33.67	37.66	8.08	39.21	2.46	42.66	53.9	11.2	150	0	VBW:10 Hz
Vert.	8175.600	AV	34.24	37.85	8.45	39.37	2.46	43.63	53.9	10.2	150	0	VBW:10 Hz
Vert.	9084.000	AV	34.11	38.06	9.21	39.70	2.46	44.14	53.9	9.7	150	0	VBW:10 Hz

Result = Reading + Ant. Fac. + Loss (Cable+(Attenuator or Filter)(below 18 GHz)) - Gain(Amplifier) + Distance factor

Distance factor : 1 GHz - 10 GHz : 20log(3.98 m / 3.0 m) = 2.46 dB

UL Japan, Inc.

Shonan EMC Lab.

1-22-3 Megumigaoka, Hiratsuka-shi, Kanagawa-ken, 259-1220 JAPAN

Telephone : +81 463 50 6400

Facsimile : +81 463 50 6401

Radiated Spurious Emission

Report No. 13707587S-A-R2
Test place Shonan EMC Lab.
Semi Anechoic Chamber No.2
Date March 20, 2021
Temperature / Humidity 22 deg. C / 41 % RH
Engineer Hiromasa Sato
Mode Tx 908.42 MHz

(* PK: Peak, AV: Average, QP: Quasi-Peak)

Polarity	Frequency [MHz]	Detector	Reading [dBuV]	Ant. Fac. [dB/m]	Loss [dB]	Gain [dB]	Distance Factor [dB]	Result [dBuV/m]	Limit [dBuV/m]	Margin [dB]	Height [cm]	Angle [deg]	Remark
Hori.	908.420	QP	87.84	22.15	9.51	30.80	0.00	88.70	93.9	5.2	101	164	Carrier
Hori.	1816.840	PK	44.51	25.81	4.51	38.96	2.46	38.33	73.9	35.5	224	267	-
Hori.	2725.260	PK	44.54	28.43	5.04	38.53	2.46	41.94	73.9	31.9	154	114	-
Hori.	3633.680	PK	53.04	29.76	5.74	38.16	2.46	52.84	73.9	21.0	156	36	-
Hori.	4542.100	PK	44.22	31.06	6.35	38.55	2.46	45.54	73.9	28.3	150	0	-
Hori.	5450.520	PK	48.87	32.47	7.06	38.80	2.46	52.06	73.9	21.8	177	143	-
Hori.	6358.940	PK	44.71	34.34	7.66	39.01	2.46	50.16	73.9	23.7	150	0	-
Hori.	7267.360	PK	44.73	37.66	8.08	39.21	2.46	53.72	73.9	20.1	150	0	-
Hori.	8175.780	PK	45.42	37.85	8.45	39.37	2.46	54.81	73.9	19.0	150	0	-
Hori.	9084.200	PK	44.60	38.06	9.21	39.70	2.46	54.63	73.9	19.2	150	0	-
Hori.	1816.840	AV	33.73	25.81	4.51	38.96	2.46	27.55	53.9	26.3	224	267	VBW:10 Hz
Hori.	2725.260	AV	33.22	28.43	5.04	38.53	2.46	30.62	53.9	23.2	154	114	VBW:10 Hz
Hori.	3633.680	AV	49.26	29.76	5.74	38.16	2.46	49.06	53.9	4.8	156	36	VBW:10 Hz
Hori.	4542.100	AV	32.88	31.06	6.35	38.55	2.46	34.20	53.9	19.7	150	0	VBW:10 Hz
Hori.	5450.520	AV	41.45	32.47	7.06	38.80	2.46	44.64	53.9	9.2	177	143	VBW:10 Hz
Hori.	6358.940	AV	33.18	34.34	7.66	39.01	2.46	38.63	53.9	15.2	150	0	VBW:10 Hz
Hori.	7267.360	AV	33.63	37.66	8.08	39.21	2.46	42.62	53.9	11.2	150	0	VBW:10 Hz
Hori.	8175.780	AV	33.78	37.85	8.45	39.37	2.46	43.17	53.9	10.7	150	0	VBW:10 Hz
Hori.	9084.200	AV	34.18	38.06	9.21	39.70	2.46	44.21	53.9	9.6	150	0	VBW:10 Hz
Vert.	908.420	QP	85.82	22.15	9.51	30.80	0.00	86.68	93.9	7.2	127	180	Carrier
Vert.	1816.840	PK	45.12	25.81	4.51	38.96	2.46	38.94	73.9	34.9	119	218	-
Vert.	2725.260	PK	44.44	28.43	5.04	38.53	2.46	41.84	73.9	32.0	165	211	-
Vert.	3633.680	PK	51.78	29.76	5.74	38.16	2.46	51.58	73.9	22.3	374	170	-
Vert.	4542.100	PK	44.23	31.06	6.35	38.55	2.46	45.55	73.9	28.3	150	0	-
Vert.	5450.520	PK	47.09	32.47	7.06	38.80	2.46	50.28	73.9	23.6	104	299	-
Vert.	6358.940	PK	44.86	34.34	7.66	39.01	2.46	50.31	73.9	23.5	150	0	-
Vert.	7267.360	PK	43.30	37.66	8.08	39.21	2.46	52.29	73.9	21.6	150	0	-
Vert.	8175.780	PK	44.26	37.85	8.45	39.37	2.46	53.65	73.9	20.2	150	0	-
Vert.	9084.200	PK	45.41	38.06	9.21	39.70	2.46	55.44	73.9	18.4	150	0	-
Vert.	1816.840	AV	33.29	25.81	4.51	38.96	2.46	27.11	53.9	26.7	119	218	VBW:10 Hz
Vert.	2725.260	AV	32.59	28.43	5.04	38.53	2.46	29.99	53.9	23.9	165	211	VBW:10 Hz
Vert.	3633.680	AV	47.45	29.76	5.74	38.16	2.46	47.25	53.9	6.6	374	170	VBW:10 Hz
Vert.	4542.100	AV	32.83	31.06	6.35	38.55	2.46	34.15	53.9	19.7	150	0	VBW:10 Hz
Vert.	5450.520	AV	39.08	32.47	7.06	38.80	2.46	42.27	53.9	11.6	104	299	VBW:10 Hz
Vert.	6358.940	AV	33.66	34.34	7.66	39.01	2.46	39.11	53.9	14.7	150	0	VBW:10 Hz
Vert.	7267.360	AV	33.65	37.66	8.08	39.21	2.46	42.64	53.9	11.2	150	0	VBW:10 Hz
Vert.	8175.780	AV	34.19	37.85	8.45	39.37	2.46	43.58	53.9	10.3	150	0	VBW:10 Hz
Vert.	9084.200	AV	34.20	38.06	9.21	39.70	2.46	44.23	53.9	9.6	150	0	VBW:10 Hz

Result = Reading + Ant. Fac. + Loss (Cable+(Attenuator or Filter)(below 18 GHz)) - Gain(Amplifier) + Distance factor

Distance factor : 1 GHz - 10 GHz : 20log(3.98 m / 3.0 m) = 2.46 dB

UL Japan, Inc.

Shonan EMC Lab.

1-22-3 Megumigaoka, Hiratsuka-shi, Kanagawa-ken, 259-1220 JAPAN

Telephone : +81 463 50 6400

Facsimile : +81 463 50 6401

Radiated Spurious Emission

Report No. 13707587S-A-R2
Test place Shonan EMC Lab.
Semi Anechoic Chamber No.2
Date March 20, 2021
Temperature / Humidity 22 deg. C / 41 % RH
Engineer Hiromasa Sato
Mode Tx 916 MHz

(* PK: Peak, AV: Average, QP: Quasi-Peak)

Polarity	Frequency [MHz]	Detector	Reading [dBuV]	Ant.Fac. [dB/m]	Loss [dB]	Gain [dB]	Distance Factor [dB]	Result [dBuV/m]	Limit [dBuV/m]	Margin [dB]	Height [cm]	Angle [deg]	Remark
Hori.	916.000	QP	89.75	22.05	9.54	30.74	0.00	90.60	93.9	3.3	109	193	Carrier
Hori.	928.000	QP	20.68	21.97	9.59	30.65	0.00	21.59	46.0	24.4	109	193	-
Hori.	1832.000	PK	44.52	25.85	4.50	38.95	2.46	38.38	73.9	35.5	225	110	-
Hori.	2748.000	PK	44.72	28.49	5.05	38.52	2.46	42.20	73.9	31.7	143	211	-
Hori.	3664.000	PK	52.93	29.83	5.76	38.16	2.46	52.82	73.9	21.0	100	83	-
Hori.	4580.000	PK	44.51	31.15	6.38	38.55	2.46	45.95	73.9	27.9	150	0	-
Hori.	5496.000	PK	50.35	32.61	7.09	38.83	2.46	53.68	73.9	20.2	169	203	-
Hori.	6412.000	PK	43.93	34.60	7.70	39.00	2.46	49.69	73.9	24.2	150	0	-
Hori.	7328.000	PK	44.37	37.75	8.10	39.29	2.46	53.39	73.9	20.5	150	0	-
Hori.	8244.000	PK	44.60	37.55	8.50	39.41	2.46	53.70	73.9	20.2	150	0	-
Hori.	9160.000	PK	44.17	38.35	9.25	39.71	2.46	54.52	73.9	19.3	150	0	-
Hori.	1832.000	AV	33.17	25.85	4.50	38.95	2.46	27.03	53.9	26.8	225	110	VBW:10 Hz
Hori.	2748.000	AV	33.56	28.49	5.05	38.52	2.46	31.04	53.9	22.8	143	211	VBW:10 Hz
Hori.	3664.000	AV	49.42	29.83	5.76	38.16	2.46	49.31	53.9	4.5	100	83	VBW:10 Hz
Hori.	4580.000	AV	33.38	31.15	6.38	38.55	2.46	34.82	53.9	19.0	150	0	VBW:10 Hz
Hori.	5496.000	AV	45.19	32.61	7.09	38.83	2.46	48.52	53.9	5.3	169	203	VBW:10 Hz
Hori.	6412.000	AV	33.02	34.60	7.70	39.00	2.46	38.78	53.9	15.1	150	0	VBW:10 Hz
Hori.	7328.000	AV	33.23	37.75	8.10	39.29	2.46	42.25	53.9	11.6	150	0	VBW:10 Hz
Hori.	8244.000	AV	33.29	37.55	8.50	39.41	2.46	42.39	53.9	11.5	150	0	VBW:10 Hz
Hori.	9160.000	AV	33.10	38.35	9.25	39.71	2.46	43.45	53.9	10.4	150	0	VBW:10 Hz
Vert.	916.000	QP	87.84	22.05	9.54	30.74	0.00	88.69	93.9	5.2	129	144	Carrier
Vert.	928.000	QP	20.87	21.97	9.59	30.65	0.00	21.78	46.0	24.2	129	144	-
Vert.	1832.000	PK	45.01	25.85	4.50	38.95	2.46	38.87	73.9	35.0	103	191	-
Vert.	2748.000	PK	45.17	28.49	5.05	38.52	2.46	42.65	73.9	31.2	156	246	-
Vert.	3664.000	PK	51.24	29.83	5.76	38.16	2.46	51.13	73.9	22.7	369	153	-
Vert.	4580.000	PK	43.89	31.15	6.38	38.55	2.46	45.33	73.9	28.5	150	0	-
Vert.	5496.000	PK	47.03	32.61	7.09	38.83	2.46	50.36	73.9	23.5	100	311	-
Vert.	6412.000	PK	44.26	34.60	7.70	39.00	2.46	50.02	73.9	23.8	150	0	-
Vert.	7328.000	PK	44.53	37.75	8.10	39.29	2.46	53.55	73.9	20.3	150	0	-
Vert.	8244.000	PK	44.69	37.55	8.50	39.41	2.46	53.79	73.9	20.1	150	0	-
Vert.	9160.000	PK	44.67	38.35	9.25	39.71	2.46	55.02	73.9	18.8	150	0	-
Vert.	1832.000	AV	33.22	25.85	4.50	38.95	2.46	27.08	53.9	26.8	103	191	VBW:10 Hz
Vert.	2748.000	AV	32.43	28.49	5.05	38.52	2.46	29.91	53.9	23.9	156	246	VBW:10 Hz
Vert.	3664.000	AV	47.18	29.83	5.76	38.16	2.46	47.07	53.9	6.8	369	153	VBW:10 Hz
Vert.	4580.000	AV	32.81	31.15	6.38	38.55	2.46	34.25	53.9	19.6	150	0	VBW:10 Hz
Vert.	5496.000	AV	38.95	32.61	7.09	38.83	2.46	42.28	53.9	11.6	100	311	VBW:10 Hz
Vert.	6412.000	AV	33.39	34.60	7.70	39.00	2.46	39.15	53.9	14.7	150	0	VBW:10 Hz
Vert.	7328.000	AV	33.85	37.75	8.10	39.29	2.46	42.87	53.9	11.0	150	0	VBW:10 Hz
Vert.	8244.000	AV	34.11	37.55	8.50	39.41	2.46	43.21	53.9	10.6	150	0	VBW:10 Hz
Vert.	9160.000	AV	34.02	38.35	9.25	39.71	2.46	44.37	53.9	9.5	150	0	VBW:10 Hz

Result = Reading + Ant.Fac. + Loss (Cable+(Attenuator or Filter)(below 18 GHz)) - Gain(Amplifier) + Distance factor

Distance factor : 1 GHz - 10 GHz : 20log(3.98 m / 3.0 m) = 2.46 dB

UL Japan, Inc.

Shonan EMC Lab.

1-22-3 Megumigaoka, Hiratsuka-shi, Kanagawa-ken, 259-1220 JAPAN

Telephone : +81 463 50 6400

Facsimile : +81 463 50 6401

Radiated Spurious Emission (Plot data)

Report No. 13707587S-A-R2
 Test place Shonan EMC Lab.
 Semi Anechoic Chamber No.2
 Date March 20, 2021
 Temperature / Humidity 22 deg. C / 41 % RH
 Engineer Hiromasa Sato

Tx 908.4 MHz

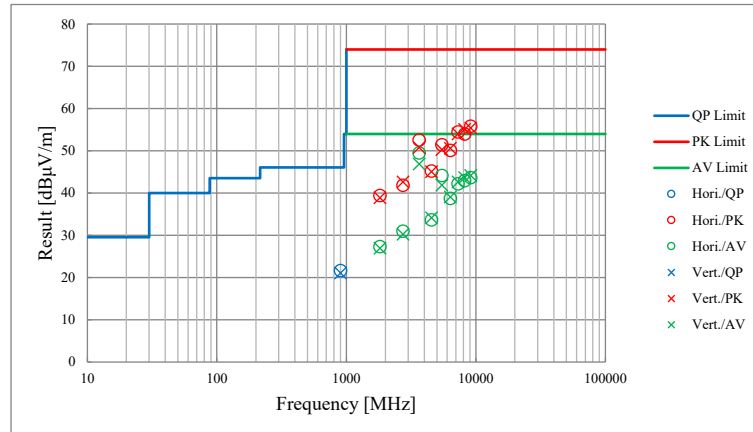

Tx 908.42 MHz

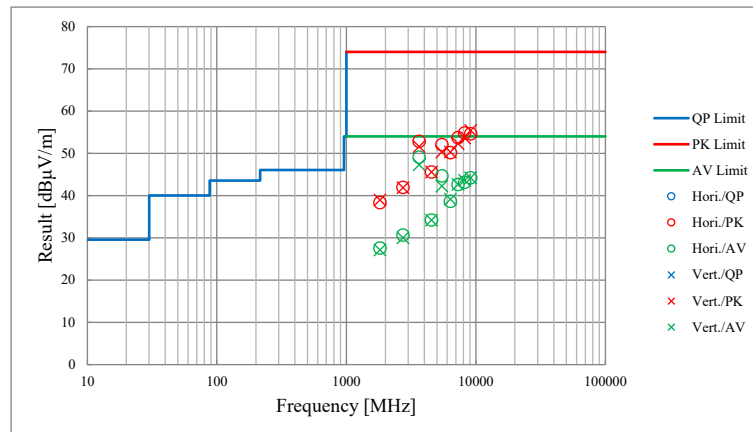

Tx 916 MHz

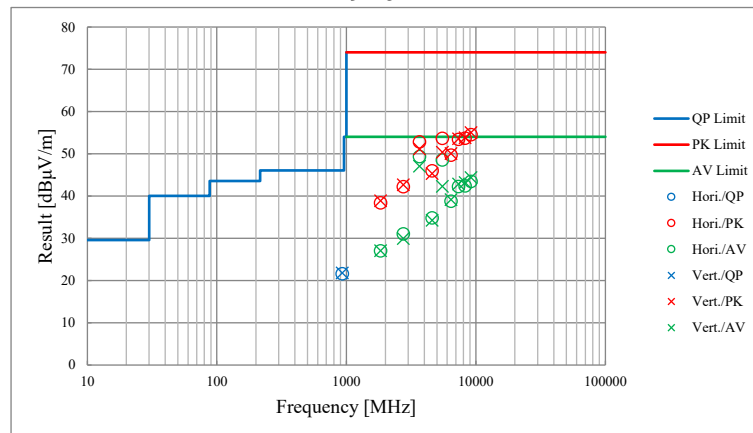

*These plots data contains sufficient number to show the trend of characteristic features for EUT.

APPENDIX 2: Test instruments

Test equipment (1 / 2)

Test Name	Local ID	LIMS ID	Description	Manufacturer	Model	Serial	Last Calibration Date	Calibration Interval (Month)
AT	KSA-08	145089	Spectrum Analyzer	Keysight Technologies Inc	E4446A	MY46180525	2020/11/24	12
AT	SAT10-05	145136	Attenuator(above 1GHz)	Keysight Technologies Inc	8493C-010	74864	2020/10/05	12
AT	SCC-G65	196942	Coaxial Cable	HUBER+SUNER	SUCOFLEX 102	803416/2	2020/03/10	12
AT,CE	KTS-06	145110	Digital Tester	SANWA	PC500	7019240	2020/04/09	12
AT,CE	SOS-05	146293	Humidity Indicator	A&D	AD-5681	4062518	2020/09/30	12
CE	KAT3-12	144896	Attenuator	JFW IND. INC.	50HF-003N	-	2020/07/16	12
CE	SCC-05	145033	Coaxial Cable	Fujikura,HP,Mini-Circuits,Fujikura	5D2W	-	2020/04/17	12
CE	SJM-18	147480	Measure	ASKUL	-	-	-	-
CE	SLS-03	145540	LISN	Rohde & Schwarz	ENV216	100513	2021/02/12	12
CE	STR-06	146208	Test Receiver	Rohde & Schwarz	ESCI	101259	2020/04/01	12
RE	COTS-SEMI-5	170932	EMI Software	TSJ	TEPTO-DV3(RE,CE,ME,PE)	-	-	-
RE	SAEC-02(NSA)	145563	Semi-Anechoic Chamber	TDK	SAEC-02(NSA)	2	2020/03/20	12
RE	SAEC-02(SVSWR)	145598	Semi-Anechoic Chamber	TDK	SAEC-02(SVSWR)	2	2020/05/07	12
RE	SAF-02	145004	Pre Amplifier	SONOMA	310N	290212	2021/02/10	12
RE	SAF-05	145128	Pre Amplifier	Toyo Corporation	TPA0118-36	1440490	2020/06/03	12
RE	SAT10-06	145137	Attenuator	Keysight Technologies Inc	8493C-010	74865	2020/10/05	12
RE	SAT3-11	150921	Attenuator	JFW	50HF-003N	-	2021/01/26	12
RE	SAT6-14	167095	Attenuator	JFW	50HF-006N	-	2021/02/10	12
RE	SAT6-15	167096	Attenuator	JFW	50HF-006N	-	2021/02/10	12
RE	SBA-02	145022	Biconical Antenna	Schwarzbeck	BBA9106	91032665	2020/04/04	12

Test equipment (2 / 2)

Test Name	Local ID	LIMS ID	Description	Manufacturer	Model	Serial	Last Calibration Date	Calibration Interval (Month)
RE	SCC-B1/B3/B5/B7/B8/B13/SRSE-02	144975	Coaxial Cable&RF Selector	Fujikura/Fujikura/Suhner/Suhner/TOYO	8D2W/12DSFA/141PE/141PE/141PE/141PE/NS4906	-/0901-270(RF Selector)	2020/04/17	12
RE	SCC-B2/B4/B6/B7/B8/B13/SRSE-02	144976	Coaxial Cable&RF Selector	Fujikura/Fujikura/Suhner/Suhner/TOYO	8D2W/12DSFA/141PE/141PE/141PE/141PE/NS4906	-/0901-270(RF Selector)	2020/04/17	12
RE	SCC-G41	151617	Coaxial Cable	Junkosha	MWX221-01000NFSNMS/B	1612S006	2021/01/19	12
RE	SCC-G50	178573	Coaxial Cable	HUBER+SUNER	SUCOFLEX_104 E	MY13407/4E	2020/03/09	12
RE	SCC-G51	178572	Coaxial Cable	HUBER+SUNER	SUCOFLEX 104	800288 /4A	2020/03/09	12
RE	SCC-M1	194601	Coaxial Cable	Fjikura	5D-2W	-	2020/12/10	12
RE	SFL-22	168802	Highpass Filter	MICRO-TRONICS	HPM50114	G035	2020/04/02	12
RE	SHA-02	145384	Horn Antenna	Schwarzbeck	BBHA9120D	9120D-726	2020/06/15	12
RE	SJM-09	145336	Measure	PROMART	SEN1935	-	-	-
RE	SLA-06	145528	Logperiodic Antenna	Schwarzbeck	VUSLP9111B	195	2020/04/04	12
RE	SLP-02	145536	Loop Antenna	Rohde & Schwarz	HFH2-Z2	100218	2020/04/15	12
RE	SOS-21	191838	Humidity Indicator	CUSTOM	CTH-201	-	2020/09/28	12
RE	STR-07	146209	Test Receiver	Rohde & Schwarz	ESU26	100484	2020/09/07	12
RE	STS-02	145793	Digital Hitester	HIOKI	3805-50	80997819	2020/04/09	12

*Hyphens for Last Calibration Date and Cal Int (month) are instruments that Calibration is not required (e.g. software), or instruments checked in advance before use.

The expiration date of the calibration is the end of the expired month.

As for some calibrations performed after the tested dates, those test equipment have been controlled by means of an unbroken chains of calibrations.

All equipment is calibrated with valid calibrations. Each measurement data is traceable to the national or international standards.

Test item: CE: Conducted Emission test
RE: Radiated Emission test
AT: Antenna Terminal Conducted test