

APPENDIX 1: Photographs of test setup

Appendix 1-1: Photograph of EUT, Platform, antenna position

EUT



Antenna position

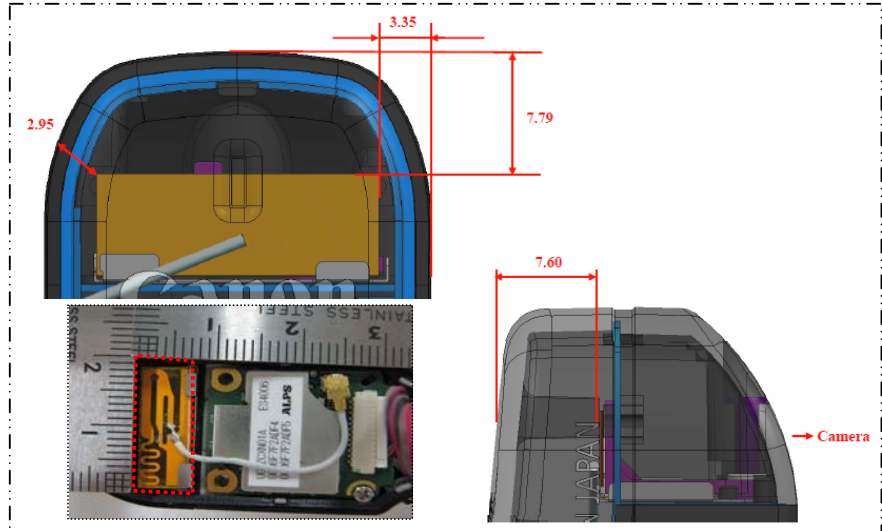

Platform

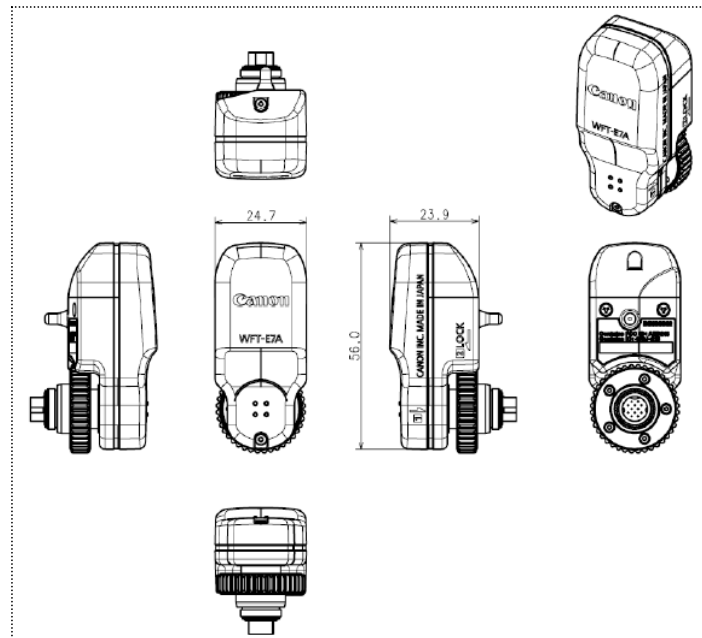
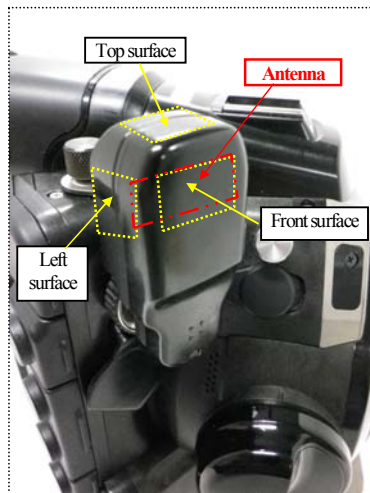

Appendix 1-2: Photograph of host device

Host device:
HD camcorder

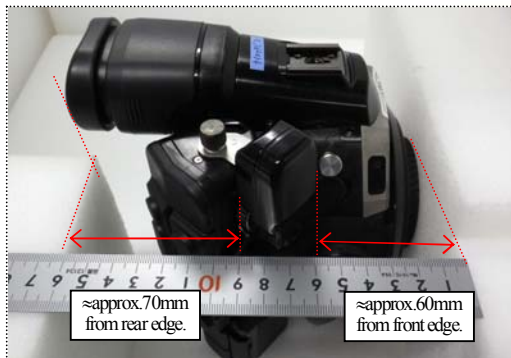

Information of the HD camcorder

The Wireless File transmitter equipped with the EUT is installed only on a limited HD camcorder that specified in below.

Type of Equipment:	HD camcorder
Model:	DV0001
Size:	133 (W) × 179 (H) × 171 (D) (mm)

Appendix 1-3: EUT configuration









Description of EUT and Support Equipment

No.	Item	Model number	Serial number	Manufacturer	Remark
A	Wireless Module	CH9-1214	06	Canon	EUT.
B	Wireless File transmitter	DS585862	06	Canon	Platform
C	HD camcorder	DV0001	DD No.29	Canon	Host device.
D1	Battery Pack	BP-955	01	Canon	Support equipment, Battery No."1".
D2			02		Support equipment, Battery No."2".
E	Compact power adaptor	CA-930	31	Canon	Support equipment.
F	I/F PCB	RS232C TO USB	123	Canon	Support equipment.
G	Note PC	PC-LG15FCNGJ	0000A6D7-03C0-4751-81D4-DB7332809C4F	NEC	Support equipment.
H	AC Adaptor (for note PC)	ADP-60JH	4902593DA	NEC	Support equipment.





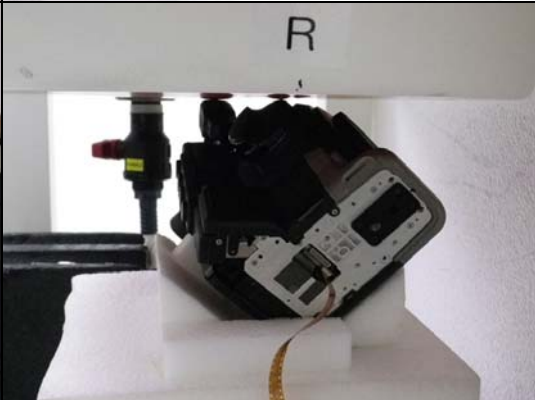

List of cables used

No.	Name	Length (m)	Shield	Shell type	Remark
①	Ribbon flat cable	0.2	Unshielded	None	-
②	USB cable	1.5	Shielded	Metal	-
③	DC cable (AC adaptor)	1.8	Unshielded	None	-
④	AC cable (AC adaptor)	1.8	Unshielded	None	-
⑤	AC cable (Battery charger)	1.5	Unshielded	None	-

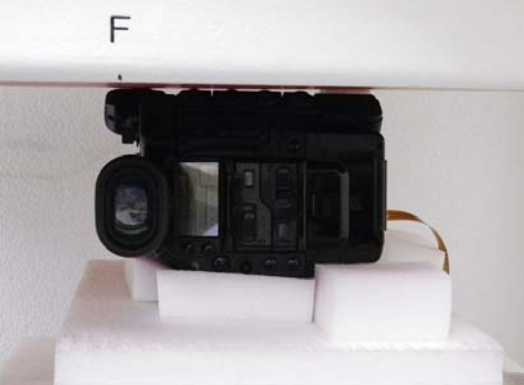
Appendix 1-4: Photograph of test setup

Position	Setup photograph	Setup photograph
Top & touch	<p style="text-align: center;">F</p> 	
	<p style="text-align: center;">L</p> 	<p style="text-align: center;">R</p> 
Front & touch	<p style="text-align: center;">F</p> 	
	<p style="text-align: center;">L</p> 	<p style="text-align: center;">R</p> 

Appendix 1-4: Photograph of test setup (cont'd)

Position	Setup photograph	Setup photograph
Left-front & touch	 A black camera is mounted on a white foam block. The letter 'F' is written on the white surface above the camera.	 A close-up view of the camera setup, showing the lens and the camera body resting on the white foam block.
	 A camera is mounted on a white foam block. The letter 'L' is written on the white surface above the camera.	 A close-up view of the camera setup, showing the lens and the camera body resting on the white foam block.
	 A camera is mounted on a white foam block. The letter 'R' is written on the white surface above the camera.	 A close-up view of the camera setup, showing the lens and the camera body resting on the white foam block.