

 <b>MOTOROLA SOLUTIONS</b>	    <p>MS ISO/IEC 17025 TESTING SAMM No. 0826 <b>CERTIFICATE 2518.05</b></p>
---	---

**DECLARATION OF COMPLIANCE: MPE ASSESSMENT**

<p><b>Motorola Solutions Inc. EME Test Laboratory</b> Motorola Solutions Malaysia Sdn Bhd Plot 2A, Medan Bayan Lepas, Mukim 12 SWD 11900 Bayan Lepas Penang, Malaysia.</p>	<p><b>Date of Report:</b> 08/04/2022 <b>Report Revision:</b> B</p>
--	--

<b>Responsible Engineer:</b>	Saw Sun Hock (EME Engineer)
<b>Report author:</b>	Sin Keng LEE (EME Engineer)
<b>Date(s) Tested:</b>	1/25/2021 - 1/31/2021
<b>Manufacturer:</b>	Motorola Solutions Inc.
<b>Date submitted for test:</b>	1/22/2021
<b>DUT Description:</b>	APX 6500 8/900MHz - Multiple HW Encryption WiFi Interoperability Data Modem Tethering via WiFi or Cable
<b>Test TX mode(s):</b>	CW
<b>Max. Power output:</b>	Refer to Table 6
<b>TX Frequency Bands:</b>	Refer to Table 6
<b>Signaling type:</b>	FM, TDMA, FHSS (Bluetooth / Bluetooth LE), 802.11b/g/n (WLAN 2.4 GHz), 802.11 a/n/ac (WLAN 5 GHz)
<b>Model(s) Tested:</b>	M25VRS9PW1CN (PMUF1980A)
<b>Model(s) Certified:</b>	M25VRS9PW1CN (PMUF1980A), M22VRS9PW1CN (PMUF1980A)
<b>Serial Number(s):</b>	471TX81927
<b>Classification:</b>	Occupational/Controlled Environment
<b>Applicant Name:</b>	Motorola Solutions Inc.
<b>Applicant Address:</b>	8000 West Sunrise Boulevard, Fort Lauderdale, Florida 33322
<b>FCC ID:</b>	AZ492FT7141 LMR 806-824 MHz, 851-869 MHz, 896-901 MHz, 935-940 MHz, Bluetooth 2402-2480 MHz, WLAN 2412-2462 MHz; WLAN 5180-5825 MHz This report contains results that are immaterial for FCC equipment approval, which are clearly identified.
<b>IC:</b>	109U-92FT7141 This report contains results that are immaterial for ISED Canada equipment approval, which are clearly identified.

The MPE results clearly demonstrate compliance with FCC Occupational/Controlled RF Exposure limits. FCC rules require compliance for Passengers and Bystanders to the FCC General Population/Uncontrolled limits. The test results clearly demonstrate compliance with ICNIRP Guidelines for limiting exposure in time-varying electric, magnetic, and electromagnetic fields (up to 300 GHz) and Health Canada Safety Code 6 (2015). Limits of Human Exposure to Radio frequency Electromagnetic Energy in the Frequency Range from 3 kHz to 300 GHz.

Based on the information and the testing results provided herein, the undersigned certifies that when used as stated in the operating instructions supplied, said product complies with the national and international reference standards and guidelines listed in section 4.0 of this report (no deviation from standard methods). This report shall not be reproduced without written approval from an officially designated representative of the Motorola Solutions Inc. EME Laboratory. I attest to the accuracy of the data and assume full responsibility for the completeness of these measurements. This reporting format is consistent with the suggested guidelines of the TIA TSB-159 April 2006. The results and statements contained in this report pertain only to the device(s) evaluated herein.

 <b>Saw Sun Hock (Approved Signatory) Approval Date: 8/9/2022</b>	
---	--

**Document Revision History**

<b>Date</b>	<b>Revision</b>	<b>Comments</b>
04/21/2022	A	Initial release
08/04/2022	B	Update the Model Name

**Table of Contents**

1.0 Introduction ..... 4

2.0 FCC MPE Summary..... 4

3.0 Abbreviations / Definitions ..... 4

4.0 Referenced Standards and Guidelines..... 5

5.0 Power Density Limits ..... 5

6.0 N<sub>c</sub> Test Channels ..... 7

7.0 Measurement Equipment ..... 7

8.0 Measurement System Uncertainty Levels ..... 7

9.0 Product and System Description ..... 8

10.0 Additional Options and Accessories..... 9

11.0 Test Set-Up Description ..... 9

12.0 Method of Measurement with trunk mounted antenna(s)..... 9

    12.1 External/Bystander vehicle MPE measurements ..... 9

    12.2 Internal/Passenger vehicle MPE measurements ..... 10

13.0 Method of Measurement with roof mounted antenna(s) ..... 11

    13.1 External/Bystander vehicle MPE measurements ..... 11

    13.2 Internal/Passenger vehicle MPE measurements ..... 11

14.0 MPE Variability Requirement for External/Bystander vehicle MPE measurement..... 12

15.0 MPE Calculations..... 12

16.0 Antenna Summary ..... 13

17.0 Test Results Summary ..... 14

    17.1 MPE Test Results Summary for LMR..... 14

    17.2 MPE Test Results for Bluetooth and WLAN ..... 26

    17.3 Simultaneous Transmission..... 28

18.0 Conclusion ..... 29

19.0 User Instructions Considerations ..... 29

Appendix A - Antenna Locations, Test Distances, and Cable Losses ..... 30

Appendix B - Probe Calibration Certificates ..... 35

Appendix C - Photos of Assessed Antennas..... 39

Appendix D - MPE Measurement Results ..... 40

### 1.0 Introduction

This report details the test setup, test equipment and test results of Maximum Permissible Exposure (MPE) performed at Motorola Solutions’ outside test site for product model M25VRS9PW1CN (PMUF1980A).

### 2.0 FCC MPE Summary

**Table 1**

Equipment Class	Frequency band (MHz)	Trunk Mounted Antennas				Roof Mounted Antennas			
		Passenger		Bystander		Passenger		Bystander	
		Power Density (mW/cm <sup>2</sup> )	Percentage of Limit (%)	Power Density (mW/cm <sup>2</sup> )	Percentage of Limit (%)	Power Density (mW/cm <sup>2</sup> )	Percentage of Limit (%)	Power Density (mW/cm <sup>2</sup> )	Percentage of Limit (%)
TNB	806-824, 851-869, 896-901, 935-940 (LMR 8/900)	0.211	38.9	0.107	19.9	0.035	6.40	0.067	12.5
DTS	2412 – 2462 (WLAN 2.4 GHz)	0.018	1.77	0.018	1.77	0.018	1.77	0.018	1.77
NII	5180 - 5825 (WLAN 5 GHz)	0.007	0.67	0.007	0.67	0.007	0.67	0.007	0.67
DSS	2402-2480 (Bluetooth)	0.005	0.50	0.005	0.50	0.005	0.50	0.005	0.50
Simultaneous (Highest Combined Percentage of Limit)			40.7		21.7		8.2		14.3

### 3.0 Abbreviations / Definitions

- BT: Bluetooth
- CNR: Calibration Not Required
- CW: Continuous Wave
- DUT: Device Under Test
- EME: Electromagnetic Energy
- FHSS: Frequency Hopping Spread Spectrum
- FM: Frequency Modulation
- MPE: Maximum Permissible Exposure
- GPS: Global Positioning System
- LMR: Land Mobile Radio
- NA: Not Applicable
- BS: Bystander
- PB: Passenger Back seat
- PF: Passenger Front seat
- PTT: Push to Talk
- WLAN: Wireless Local Area Network
- TDMA: Time Division Multiple Access

#### 4.0 Referenced Standards and Guidelines

This product is designed to comply with the following applicable national and international standards and guidelines.

- United States Federal Communications Commission, Code of Federal Regulations; Rule Part 47CFR § 1.1310, § 2.1091 (d) and § 2.1093 for RF Exposure, where applicable.
- Federal Communications Commission, “Evaluating Compliance with FCC Guidelines for Human Exposure to Radio frequency Electromagnetic Fields”, OET Bulletin 65 (Edition 97-01), FCC, Washington, D.C.: August 1997.
- Institute of Electrical and Electronics Engineers (IEEE) C95. 1-2019
- American National Standards Institute (ANSI) / Institute of Electrical and Electronics Engineers (IEEE) C95. 1-1992. Specific to FCC rules and regulations.
- Institute of Electrical and Electronics Engineers (IEEE) C95.3-2002
- International Commission on Non-Ionizing Radiation Protection (ICNIRP) 1998
- Ministry of Health (Canada) Safety Code 6 (2015), Limits of Human Exposure to Radio frequency Electromagnetic Fields in the Frequency Range from 3 kHz to 300 GHz
- RSS-102 (Issue 5) – Radio Frequency (RF) Exposure Compliance of Radio communication Apparatus (All Frequency Bands)
- FCC KDB – 447498 D01 General RF Exposure Guidance v06
- FCC KDB – 865664 D02 RF Exposure Reporting v01r02
- EN 62311:2008 Assessment of electronic and electrical equipment related to human exposure restrictions for electromagnetic fields (0 Hz – 300 GHz).

#### 5.0 Power Density Limits

**Table 2 – Occupational / Controlled Exposure Limits**

Frequency Range (MHz)	FCC OET Bulletin 65/ 47CFR § 1.1310	ICNIRP	IEEE C95.1 2019	RSS-102 Issue 5 2015
	mW/cm <sup>2</sup>	W/m <sup>2</sup>	W/m <sup>2</sup>	W/m <sup>2</sup>
10 – 20				10.0
20 – 48				$44.72 / f^{0.5}$
30 – 300	1.0			
48 – 100				6.455
10 – 400		10.0		
100 – 400			10.0	
100 – 6,000				$0.6455 f^{0.5}$
300 – 1,500	f/300			

**Table 2 – Occupational / Controlled Exposure Limits (Con’t.)**

Frequency Range (MHz)	FCC OET Bulletin 65/ 47CFR § 1.1310	ICNIRP	IEEE C95.1 2019	RSS-102 Issue 5 2015
	mW/cm <sup>2</sup>			
400 – 2,000		f/40	f/40	
1,500 – 100,000	5.0			
2,000 – 300,000		50.0	50.0	
6,000 – 15,000				50.0
15000 – 150,000				50.0
150000 – 300,000				$3.33 \times 10^{-4} f$

**Table 3 – General Population / Uncontrolled Exposure Limits**

Frequency Range (MHz)	FCC OET Bulletin 65/ 47CFR § 1.1310	ICNIRP	IEEE C95.1 2019	RSS-102 Issue 5 2015
	mW/cm <sup>2</sup>			
10 – 20				2.0
20 – 48				$8.944 / f^{0.5}$
30 – 300	0.2			
48 – 300				1.291
10 – 400		2.0		
100 – 300				
100 – 400			2.0	
300 – 1,500	f/1,500			
300 – 6000				$0.02619 f^{0.6834}$
400 – 2,000		f/200	f/200	
1,500 – 100,000	1.0			
2,000 – 300,000		10.0	10.0	
6,000 – 15,000				10.0
15,000 – 150,000				10.0
150,000 – 300,000				$6.67 \times 10^{-5} f$

### 6.0 $N_c$ Test Channels

The number of test channels is determined by using Equation 1 below. This equation is available in FCC’s KDB 447498. The test channels are appropriately spaced across the antenna’s frequency range.

#### Equation 1 – Number of test channels

$$N_c = \text{Round} \{ [100(f_{\text{high}} - f_{\text{low}})/f_c]^{0.5} \times (f_c / 100)^{0.2} \}$$

where  $N_c$  is the number of test channels,  $f_{\text{high}}$  and  $f_{\text{low}}$  are the highest and lowest frequencies within the transmission band,  $f_c$  is the mid-band frequency, and frequencies are in MHz.

### 7.0 Measurement Equipment

**Table 4 – Equipment**

Equipment Type	Model #	SN	Calibration Date	Calibration Due Date
Automobile	Volvo 240-1988	NA	NA	NA
Survey Meter Probe – E-Field	ETS Model HI-2200 ETS Model E100	00086887 00224511	05/06/2020	05/06/2021

E-field measurements are in mW/cm<sup>2</sup>.

### 8.0 Measurement System Uncertainty Levels

**Table 5 – Uncertainty Budget for Near Field Probe Measurements**

	Tol. (± %)	Prob. Dist.	Divisor	$u_i$ (± %)		$v_i$
<b>Measurement System</b>						
Probe Calibration	7.1	N	1.00	7.1	50.4	∞
Survey Meter Calibration	0.0	N	1.00	0.0	0.0	¥
Hemispherical Isotropy	8.0	R	1.73	4.6	21.33	∞
Linearity	5.0	R	1.73	2.9	8.33	∞
Pulse Response	1.0	R	1.73	0.6	0.33	∞
RF Ambient Noise	3.0	R	1.73	1.7	3.00	∞
RF Reflections	8.0	R	1.73	4.6	21.33	∞
Probe Positioning	10.0	R	1.73	5.8	33.333	∞
<b>Test sample Related</b>					0.00	
Antenna Positioning	3.0	N	1.00	3.0	9.0	∞
Power drift	5.0	R	1.73	2.9	8.33	∞
Bystander measurement uncertainty	4.8	N	1.00	4.8	23.04	∞
Passenger measurement uncertainty	8.1	N	1.00	8.1	65.61	∞
<b>Combined Standard Uncertainty</b>		RSS		15.6	15.6	∞
<b>Expanded Uncertainty</b> (95% CONFIDENCE LEVEL)		$k=2$		31	31	

### 9.0 Product and System Description

This mobile device operates in the LMR bands using either frequency modulation (FM) with 100% transmit duty cycle or TDMA signals with maximum of 50% transmit duty cycle. For conservative assessment, FM signal was tested. A duty factor of 50% applies for PTT operation mode.

This device also incorporates a Class 1 Bluetooth device which is a Frequency Hopping Spread Spectrum (FHSS) technology. The Bluetooth radio modem is used to wireless link audio accessories. The maximum actual transmission duty cycle is imposed by the Bluetooth standard. The maximum duty cycle for BT is 100%. Bluetooth Low Energy (BT LE) intended to reduce power consumption.

This device also contains WLAN technology for data capabilities over 802.11b/g/n 2.4 GHz and 802.11 a/n/ac 5 GHz wireless networks.

Table 6 below summarizes the technologies, bands, maximum duty cycles and maximum output powers. Maximum output powers are defined as upper limit of the production line final test station.

**Table 6**

Technologies	Bands (MHz)	Duty Cycle (%)	Max Power
LMR	806-825, 851-870	50 (PTT)	42W
	896-901; 935-940		36W
	901-902; 940-941		4W
BT	2402-2480	100	11.2mW
BT LE	2402-2480	100	6.3mW
WLAN	2412 – 2462 (802.11b/g/n)	100	39.8mW (802.11b)
			7.079mW (802.11g – Channel 1 and 11), 15.8mW (802.11g – Channel 2-10)
			7.079mW (802.11n – Channel 1 and 11), 12.58mW (802.11n – Channel 2-10)
	5180-5825 (802.11 a/n/ac)	100	15.84mW

This device will be marketed to and used by employees solely for work-related operations, such as public safety agencies, e.g. police, fire and emergency medical. User training is the responsibility of these agencies which can be expected to employ the usage instructions, safety information and operational cautions set forth in the user's manual, instructional sessions or other means.

Accordingly this product is classified as Occupational/Controlled Exposure. However, in accordance with FCC requirements, the passengers inside the vehicle and the bystanders external to the vehicle are evaluated to the General Population/Uncontrolled Exposure Limits.

(Note that “Bystanders” as used herein are people other than operator)



## 10.0 Additional Options and Accessories

Not available.

## 11.0 Test Set-Up Description

Assessments were performed with mobile radio installed in the test vehicle, at the specified distances and test locations indicated in Sections 12.0, 13.0 and Appendix A.

All antennas described in Table 7 were considered in order to develop the test plan for this product. Antennas were installed and tested per their appropriate mount locations (Roof / Trunk) and defined test channels.

The system was tested using a low-loss 16' Teflon RG58A/U cable attaching the radio to the transmit antenna. This cable is shorter and lower attenuation than the 17' RG58A/U cables supplied in the customer kits for connecting the radio to the transmit antenna. The cable used in the test setup also has lower attenuation over the test frequency range than the cable provided in the customer kits. The use of a shorter cable with lower attenuation in the test setup ensures that the test data is more conservative with regards to the actual installation. Cable losses are reported in Appendix A.

## 12.0 Method of Measurement with trunk mounted antenna(s)

### 12.1 External/Bystander vehicle MPE measurements

Initially the antenna is located at the center of the trunk. Refer to Appendix A for antenna location and distance.

MPE measurements for bystander (BS) conditions are determined by taking the average of (10) measurements in a 2m vertical line for each of the (3) bystander test locations indicated in Appendix A with 20cm height increments, with the distance between the antenna and the geometric center of the probe sensor equal to 60cm (for 8/900MHz band). The measurement probe is positioned orthogonal to antenna (typically parallel to ground with a vertically mounted antenna) and aimed directly at the antenna's axis. These measurements are representative of persons other than the operator standing next to the vehicle.

Each of the offered antennas mounted at the center of the trunk were assessed at the rear of the vehicle while maintaining a minimum of twenty (20) centimeter separation distance between the probe sensor and vehicle body. The worst case antenna was then tested at a 45° radial at the corner of the trunk, and 90° radial at the side of the trunk.

Tests for the 90° radial direction were conducted with the antenna displaced towards the "bystander on the side of the trunk" test location in order to attain 60cm (42cm antenna displacement) distances from that test location. In this way, the antenna is closer to the test location, and the MPE is higher, than it would be if the antenna was left at the center of the trunk.

## 12.2 Internal/Passenger vehicle MPE measurements

Antenna is located toward the center of the trunk at a minimum 85cm from backseat passenger. Users are instructed, per installation manual, to mount antennas on the roof only if a minimum 85cm cannot be achieved. Refer to Appendix A for antenna location and distance.

MPE measurements for passenger front seat (PF) and backseat (PB) conditions are determined by taking the average of the (3) measurements (Head, Chest, and Lower Trunk) inside the vehicle for both the front and back seats.

The backseat is a bench seat and therefore each position (Head, Chest & Lower Trunk) were scanned across (horizontally) the seat starting from the middle of the seat to the edge of the seat stopping 20cm from the vehicle door. Similar process was used in the front bucket seat.

The probe handle is oriented parallel (horizontal) to the ground and pointed towards the back of the vehicle. The probe handle is not oriented normal to the seat surface. The probe head (incorporating the field sensors) is scanned continuously (using the max-hold function available in the meter) along three test axes which are parallel to the seat angle (intended as the line determined by the intersection of the plane of the seat and the plane of the backrest) and are 20cm from the seat surface. One test axis is at the Head height, another is at the Chest height, and another is at the Lower Trunk height. The maximum field level value recorded for each test axis is logged. The MPE is determined by averaging these three maximum values regardless of the geometrical location where they were observed. For instance, the locations of the three maxima may lie on different vertical (relative to ground) lines.

This approach leads to results that are representative of the exposure of vehicle occupants since it is based on an average across the body portions closest to the antenna for both trunk and roof mount positions, and is conservatively biased because the highest results for each test axis are combined, e.g. the highest head exposure could be in the middle of the seat while the highest lower trunk exposure could be closer to the door.

### **13.0 Method of Measurement with roof mounted antenna(s)**

#### **13.1 External/Bystander vehicle MPE measurements**

Antenna is located at the center of the roof. Refer to Appendix A for antenna location and distance.

MPE measurements for bystander (BS) conditions are determined by taking the average of (10) measurements in a 2m vertical line for the test location indicated in Appendix A with 20cm height increments, with the distance between the antenna and the geometric center of the probe sensor equal to 60cm (for 8/900MHz band). The measurement probe is positioned orthogonal to antenna (typically parallel to ground with a vertically mounted antenna) and aimed directly at the antenna's axis. These measurements are representative of persons other than the operator standing next to the vehicle.

#### **13.2 Internal/Passenger vehicle MPE measurements**

Antenna is located at the center of the roof. Refer to Appendix A for antenna location and distance.

MPE measurements for passenger front seat (PF) and backseat (PB) conditions are determined by taking the average of the (3) measurements (Head, Chest, and Lower Trunk) inside the vehicle for both the front and back seats.

The backseat is a bench seat and therefore each position (Head, Chest & Lower Trunk) were scanned across (horizontally) the seat starting from the middle of the seat to the edge of the seat stopping 20cm from the vehicle door. Similar process was used in the front bucket seat.

The probe handle is oriented parallel (horizontal) to the ground and pointed towards the back of the vehicle. The probe handle is not oriented normal to the seat surface. The probe head (incorporating the field sensors) is scanned continuously (using the max-hold function available in the meter) along three test axes which are parallel to the seat angle (intended as the line determined by the intersection of the plane of the seat and the plane of the backrest) and are 20cm from the seat surface. One test axis is at the Head height, another is at the Chest height, and another is at the Lower Trunk height. The maximum field level value recorded for each test axis is logged. The MPE is determined by averaging these three maximum values regardless of the geometrical location where they were observed. For instance, the locations of the three maxima may lie on different vertical (relative to ground) lines.

This approach leads to results that are representative of the exposure of vehicle occupants since it is based on an average across the body portions closest to the antenna for both trunk and roof mount positions, and is conservatively biased because the highest results for each test axis are combined, e.g. the highest head exposure could be in the middle of the seat while the highest lower trunk exposure could be closer to the door.

#### 14.0 MPE Variability Requirement for External/Bystander vehicle MPE measurement

If all the MPE bystander measurements for a particular antenna are below 50% of the FCC MPE limit, no variability testing for that antenna is required.

If one or more MPE bystander measurements for a particular is between 50-80% of the FCC MPE limit, with no results > 80%, variability testing shall be done on the single worst case for that antenna.

For any MPE bystander measurement above 80% of the MPE limit, variability testing shall be done for all of such configuration. When SAR simulation is performed for a particular antenna configuration to determine compliance, variability measurements are not required for that antenna configuration.

#### 15.0 MPE Calculations

The final MPE results for this mobile radio are presented in Section 16.0. These results are based on 50% duty cycle for PTT for LMR bands.

Below is an explanation of how the MPE results are calculated. Refer to Appendix D for MPE measurement results and calculations for LMR band.

External to vehicle (Bystander) - 10 measurements are averaged over the body (*Avg\_over\_body*).  
Internal to vehicle (Passengers) - 3 measurements are averaged over the body (*Avg\_over\_body*).

The Average over Body test methodology is consistent with IEEE/ANSI C95.3-2002 guidelines.

Therefore;

##### Equation 2 – Power Density Calculation (*Calc. P.D.*)

$$\text{Calc. P.D.} = (\text{Avg\_over\_body}) * (\text{probe\_frequency\_cal\_factor}) * (\text{duty\_cycle})$$

*Note 1: The highest “average” cal factors from the calibration certificates were selected for the applicable frequency range. Linear interpretation was used to determine “probe\_frequency\_cal\_factor” for the specific test frequencies.*

*Note 2: The E-field probe calibration certificate’s frequency cal factors were determined by measuring V/m. The survey meter’s results were measured in power density (mW/cm<sup>2</sup>) and therefore the “probe\_frequency\_cal\_factor” was squared in equation 2 to account for these results.*

*Note 3: The H-field probe calibration certificate’s frequency cal factors were determined by measuring A/m. The survey meter’s results were measured in A/m and therefore the “Avg\_over\_body” A/m results were converted to power density (mW/cm<sup>2</sup>) using the equation 3. H-field measurements are only applicable to frequencies below 300MHz.*

##### Equation 3 – Converting A/m to mW/cm<sup>2</sup>

$$\text{mW/cm}^2 = (\text{A/m})^2 * 37.699$$

**Equation 4 – Power Density Maximum Calculation**

$$Max\_Calc.\_P.D. = P.D.\_calc * \frac{max\_output\_power}{initial\_output\_power}$$

Note 4: For initial output power > max\_output\_power; max\_output\_power / initial output power = 1

**16.0 Antenna Summary**

Table below summarizes the tested or evaluated antennas and their descriptions, mount location (roof/trunk), overlap of FCC bands, number of test channels per FCC KDB 447498 (FCC N<sub>c</sub>) and actual number of tested channels (Actual N<sub>c</sub>). This information was used to determine the test configurations presented in this report.

**Table 7**

Antenna No.	Antenna Model	Frequency Range (MHz)	Physical Length (cm)	Gain (dBi)	Remarks	Mount Location (Roof/ Trunk)	Overlap FCC Bands (MHz)	FCC N <sub>c</sub>	Actual N <sub>c</sub>
1	HAF4013A	806 - 941	6.1	5.15	1/4 wave	R/T	806-941	14	14
2	HAF4036A	806 - 941	8.4	2.14	1/4 wave	R/T	806-941	14	14
3	HAF4037A	806 - 941	28.5	3.00	1/2 wave	R/T	806-941	14	14
<b>BT/WLAN</b>									
4	PMAN5100A	2400-2500	5.7 (L) x 1.9 (W)	3.0		Glass mount	2412-2462	3	3
5	PMAN5101A	2400-2500 / 4900-5900	5.4 (L) x 1.32 (W)	2.7 / 0.2		Glass mount	2412-2462 ; 5180-5825	3	3
6	AN000163A01	2400-2500 / 4900-5900	7	3.5 / 3.3	Monopole	Roof/ Trunk	2412-2462 ; 5180-5825	3	3
7	AN000163A05	2400-2500 / 4900-5900	7	2.5 / 1.6	Monopole	Roof/ Trunk	2412-2462 ; 5180-5825	3	3

### 17.0 Test Results Summary

#### 17.1 MPE Test Results Summary for LMR

**Table 8**

MPE assessment for LMR 8/900MHz - trunk mounted antenna – Bystander

Trunk/ Roof	Test Position	E/H Field	Angle (Degree)	Antenna Model	Max Pwr (W)	Initial Pwr (W)	Tx Freq (MHz)	Max Calc. P.D. (mW/ cm <sup>2</sup> )	FCC Limit	% To FCC Spec Limit	ICNIRP Limit	% To ICNIRP Spec Limit	ISED Limit	% To ISED Spec Limit
Trunk	BS	E	0	HAF4013A, 806-941MHz	42	42	806.0000	0.102	0.54	18.9	0.40	25.2	0.25	40.1
						42	815.0000	0.096	0.54	17.7	0.41	23.6	0.26	37.7
						42	824.0000	0.092	0.55	16.7	0.41	22.2	0.26	35.6
						42	851.0000	0.093	0.57	16.4	0.43	21.9	0.26	35.3
						42	860.0000	0.093	0.57	16.3	0.43	21.7	0.27	35.2
						42	869.0000	0.088	0.58	15.2	0.43	20.2	0.27	32.9
					36	36	896.0000	0.066	0.60	11.0	0.45	14.7	0.27	24.2
						36	898.5000	0.060	0.60	10.0	0.45	13.4	0.27	22.0
						36	900.0000	0.059	0.60	9.9	0.45	13.2	0.27	21.7
						36	935.0000	0.062	0.62	9.9	0.47	13.3	0.28	22.1
		36	937.5000	0.056		0.63	8.9	0.47	11.9	0.28	19.9			
		4	4	939.0000	0.056	0.63	8.9	0.47	11.9	0.28	19.8			
			4	901.5000	0.006	0.60	1.0	0.45	1.3	0.27	2.2			
		4	940.5000	0.006	0.63	0.9	0.47	1.2	0.28	2.0				
		E	0	HAF4036A, 806-941MHz	42	42	806.0000	0.100	0.54	18.6	0.40	24.8	0.25	39.4
						42	815.0000	0.090	0.54	16.5	0.41	22.0	0.26	35.1
						42	824.0000	0.080	0.55	14.6	0.41	19.5	0.26	31.2
						42	851.0000	0.077	0.57	13.5	0.43	18.0	0.26	29.1
						42	860.0000	0.076	0.57	13.3	0.43	17.7	0.27	28.7
						42	869.0000	0.073	0.58	12.6	0.43	16.8	0.27	27.3
36	36				896.0000	0.051	0.60	8.5	0.45	11.3	0.27	18.5		
	36				898.5000	0.046	0.60	7.7	0.45	10.3	0.27	16.9		
	36				900.0000	0.047	0.60	7.9	0.45	10.5	0.27	17.2		
	36				935.0000	0.049	0.62	7.9	0.47	10.5	0.28	17.5		
	36				937.5000	0.044	0.63	7.1	0.47	9.5	0.28	15.8		
	36				939.0000	0.043	0.63	6.8	0.47	9.1	0.28	15.2		
4	4				901.5000	0.005	0.60	0.8	0.45	1.1	0.27	1.9		
	4				940.5000	0.005	0.63	0.7	0.47	1.0	0.28	1.6		

**Table 8 (Continued)**

MPE assessment for LMR 8900MHz - trunk mounted antenna – Bystander

Results highlight in Bold are configurations with highest percentage of limits

Trunk/ Roof	Test Position	E/H Field	Angle (Degree)	Antenna Model	Max Pwr (W)	Initial Pwr (W)	Tx Freq (MHz)	Max Calc. P.D. (mW/ cm <sup>2</sup> )	FCC Limit	% To FCC Spec Limit	ICNIRP Limit	% To ICNIRP Spec Limit	ISED Limit	% To ISED Spec Limit					
Trunk	BS	E	0	HAF4037A, 806-941MHz	42	42	806.0000	0.107	0.54	<b>19.9</b>	0.40	<b>26.5</b>	0.25	<b>42.2</b>					
						42	815.0000	0.089	0.54	16.3	0.41	21.8	0.26	34.7					
						42	824.0000	0.088	0.55	16.0	0.41	21.3	0.26	34.0					
						42	851.0000	0.091	0.57	16.1	0.43	21.5	0.26	34.7					
						42	860.0000	0.085	0.57	14.9	0.43	19.8	0.27	32.2					
						42	869.0000	0.093	0.58	16.1	0.43	21.5	0.27	35.0					
					36	36	896.0000	0.058	0.60	9.8	0.45	13.0	0.27	21.4					
						36	898.5000	0.054	0.60	8.9	0.45	11.9	0.27	19.6					
						36	900.0000	0.054	0.60	9.0	0.45	11.9	0.27	19.6					
						36	935.0000	0.081	0.62	13.0	0.47	17.3	0.28	28.8					
						36	937.5000	0.077	0.63	12.3	0.47	16.4	0.28	27.4					
						36	939.0000	0.074	0.63	11.8	0.47	15.7	0.28	26.2					
					4	4	901.5000	0.006	0.60	0.9	0.45	1.3	0.27	2.1					
						4	940.5000	0.009	0.63	1.4	0.47	1.9	0.28	3.0					
							45		HAF4037A, 806-941MHz	42	42.0	806.0000	0.089	0.54	16.6	0.40	22.1	0.25	35.1
		90		HAF4037A, 806-941MHz	42	42.0	806.0000	0.106	0.54	19.7	0.40	26.2	0.25	41.7					

**Table 9**

MPE assessment for LMR 8900MHz - roof mounted antenna – Bystander

Trunk/ Roof	Test Position	E/H Field	Angle (Degree)	Antenna Model	Max Pwr (W)	Initial Pwr (W)	Tx Freq (MHz)	Max Calc. P.D. (mW/ cm <sup>2</sup> )	FCC Limit	% To FCC Spec Limit	ICNIRP Limit	% To ICNIRP Spec Limit	ISED Limit	% To ISED Spec Limit
Roof	BS	E	0	HAF4013A, 806-941MHz	42	42	806.0000	0.051	0.54	9.6	0.40	12.7	0.25	20.2
						42	815.0000	0.045	0.54	8.4	0.41	11.1	0.26	17.8
						42	824.0000	0.050	0.55	9.1	0.41	12.1	0.26	19.3
						42	851.0000	0.047	0.57	8.3	0.43	11.1	0.26	18.0
						42	860.0000	0.041	0.57	7.2	0.43	9.6	0.27	15.6
						42	869.0000	0.044	0.58	7.6	0.43	10.1	0.27	16.5
					36	36	896.0000	0.033	0.60	5.6	0.45	7.4	0.27	12.2
						36	898.5000	0.030	0.60	4.9	0.45	6.6	0.27	10.8
						36	900.0000	0.031	0.60	5.2	0.45	6.9	0.27	11.4
						36	935.0000	0.026	0.62	4.2	0.47	5.6	0.28	9.4
						36	937.5000	0.028	0.63	4.5	0.47	5.9	0.28	9.9
						36	939.0000	0.029	0.63	4.6	0.47	6.1	0.28	10.1
					4	4	901.5000	0.003	0.60	0.5	0.45	0.7	0.27	1.2
						4	940.5000	0.003	0.63	0.5	0.47	0.6	0.28	1.0
			0	HAF4036A, 806-941MHz	42	42	806.0000	0.050	0.54	9.2	0.40	12.3	0.25	19.6
						42	815.0000	0.044	0.54	8.0	0.41	10.7	0.26	17.1
						42	824.0000	0.048	0.55	8.8	0.41	11.7	0.26	18.8
						42	851.0000	0.040	0.57	7.1	0.43	9.4	0.26	15.3
						42	860.0000	0.042	0.57	7.3	0.43	9.7	0.27	15.7
						42	869.0000	0.038	0.58	6.6	0.43	8.8	0.27	14.4
					36	36	896.0000	0.028	0.60	4.7	0.45	6.2	0.27	10.2
						36	898.5000	0.025	0.60	4.1	0.45	5.5	0.27	9.0
						36	900.0000	0.025	0.60	4.2	0.45	5.6	0.27	9.3
						36	935.0000	0.023	0.62	3.6	0.47	4.8	0.28	8.0
36	937.5000	0.023				0.63	3.7	0.47	4.9	0.28	8.1			
36	939.0000	0.022				0.63	3.6	0.47	4.8	0.28	8.0			
4	4	901.5000			0.002	0.60	0.4	0.45	0.5	0.27	0.9			
	4	940.5000			0.002	0.63	0.4	0.47	0.5	0.28	0.9			



**Table 9 (Continued)**

MPE assessment for LMR 8/900MHz - roof mounted antenna – Bystander

Results highlight in Bold are configurations with highest percentage of limits

Trunk/ Roof	Test Position	E/H Field	Angle (Degree)	Antenna Model	Max Pwr (W)	Initial Pwr (W)	Tx Freq (MHz)	Max Calc. P.D. (mW/ cm <sup>2</sup> )	FCC Limit	% To FCC Spec Limit	ICNIRP Limit	% To ICNIRP Spec Limit	ISED Limit	% To ISED Spec Limit
Trunk	BS	E	0	HAF4037A, 806-941MHz	42	42	806.0000	0.067	0.54	<b>12.5</b>	0.40	<b>16.7</b>	0.25	<b>26.5</b>
						42	815.0000	0.057	0.54	10.4	0.41	13.9	0.26	22.2
						42	824.0000	0.062	0.55	11.4	0.41	15.2	0.26	24.3
						42	851.0000	0.054	0.57	9.5	0.43	12.6	0.26	20.4
						42	860.0000	0.055	0.57	9.6	0.43	12.8	0.27	20.8
						42	869.0000	0.052	0.58	8.9	0.43	11.9	0.27	19.3
					36	36	896.0000	0.044	0.60	7.4	0.45	9.9	0.27	16.2
						36	898.5000	0.035	0.60	5.8	0.45	7.7	0.27	12.7
						36	900.0000	0.039	0.60	6.5	0.45	8.7	0.27	14.2
						36	935.0000	0.038	0.62	6.1	0.47	8.1	0.28	13.5
						36	937.5000	0.039	0.63	6.3	0.47	8.4	0.28	14.0
					4	4	939.0000	0.039	0.63	6.2	0.47	8.2	0.28	13.7
						4	901.5000	0.005	0.60	0.9	0.45	1.2	0.27	2.0
					4	940.5000	0.005	0.63	0.8	0.47	1.0	0.28	1.7	

**Table 10**

MPE assessment for LMR 8900MHz - trunk mounted antenna – Passenger Back

Trunk/ Roof	Test Position	E/H Field	Angle (Degree)	Antenna Model	Max Pwr (W)	Initial Pwr (W)	Tx Freq (MHz)	Max Calc. P.D. (mW/ cm <sup>2</sup> )	FCC Limit	% To FCC Spec Limit	ICNIRP Limit	% To ICNIRP Spec Limit	ISED Limit	% To ISED Spec Limit
Trunk	PB	E	0	HAF4013A, 806-941MHz	42	42	806.0000	0.096	0.54	17.9	0.40	23.9	0.25	38.0
						42	815.0000	0.107	0.54	19.7	0.41	26.3	0.26	42.0
						42	824.0000	0.074	0.55	13.5	0.41	17.9	0.26	28.7
						42	851.0000	0.055	0.57	9.6	0.43	12.8	0.26	20.7
						42	860.0000	0.059	0.57	10.4	0.43	13.8	0.27	22.4
						42	869.0000	0.044	0.58	7.5	0.43	10.1	0.27	16.4
					36	36	896.0000	0.038	0.60	6.3	0.45	8.5	0.27	13.9
						36	898.5000	0.031	0.60	5.1	0.45	6.8	0.27	11.2
						36	900.0000	0.030	0.60	5.0	0.45	6.7	0.27	11.1
						36	935.0000	0.029	0.62	4.6	0.47	6.2	0.28	10.3
						36	937.5000	0.025	0.63	3.9	0.47	5.2	0.28	8.7
					4	4	939.0000	0.033	0.63	5.3	0.47	7.0	0.28	11.7
						4	901.5000	0.002	0.60	0.4	0.45	0.5	0.27	0.8
					4	940.5000	0.003	0.63	0.4	0.47	0.6	0.28	0.9	
			0	HAF4036A, 806-941MHz	42	42	806.0000	0.117	0.54	21.7	0.40	28.9	0.25	46.0
						42	815.0000	0.097	0.54	17.8	0.41	23.7	0.26	37.8
						42	824.0000	0.057	0.55	10.3	0.41	13.7	0.26	22.0
						42	851.0000	0.049	0.57	8.6	0.43	11.5	0.26	18.6
						42	860.0000	0.023	0.57	4.0	0.43	5.3	0.27	8.6
						42	869.0000	0.016	0.58	2.8	0.43	3.8	0.27	6.1
36	36	896.0000			0.019	0.60	3.2	0.45	4.3	0.27	7.0			
	36	898.5000			0.024	0.60	4.1	0.45	5.4	0.27	8.9			
	36	900.0000			0.023	0.60	3.9	0.45	5.2	0.27	8.5			
	36	935.0000			0.021	0.62	3.4	0.47	4.5	0.28	7.5			
	36	937.5000			0.022	0.63	3.6	0.47	4.8	0.28	8.0			
4	4	939.0000			0.018	0.63	2.9	0.47	3.8	0.28	6.4			
	4	901.5000			0.002	0.60	0.3	0.45	0.4	0.27	0.6			
4	940.5000	0.001			0.63	0.2	0.47	0.3	0.28	0.5				

**Table 10 (Continued)**

MPE assessment for LMR 8900MHz - trunk mounted antenna – Passenger Back

Results highlight in Bold are configurations with highest percentage of limits

Trunk/ Roof	Test Position	E/H Field	Angle (Degree)	Antenna Model	Max Pwr (W)	Initial Pwr (W)	Tx Freq (MHz)	Max Calc. P.D. (mW/ cm^2)	FCC Limit	% To FCC Spec Limit	ICNIRP Limit	% To ICNIRP Spec Limit	ISED Limit	% To ISED Spec Limit
Trunk	PB	E	0	HAF4037A, 806-941MHz	42	42	806.0000	0.188	0.54	34.9	0.40	46.6	0.25	73.9
						42	815.0000	0.211	0.54	<b>38.9</b>	0.41	<b>51.8</b>	0.26	<b>82.6</b>
						42	824.0000	0.177	0.55	32.2	0.41	43.0	0.26	68.7
						42	851.0000	0.101	0.57	17.7	0.43	23.6	0.26	38.2
						42	860.0000	0.121	0.57	21.0	0.43	28.1	0.27	45.5
						42	869.0000	0.078	0.58	13.4	0.43	17.9	0.27	29.1
					36	36	896.0000	0.045	0.60	7.6	0.45	10.1	0.27	16.6
						36	898.5000	0.067	0.60	11.3	0.45	15.0	0.27	24.7
						36	900.0000	0.059	0.60	9.9	0.45	13.2	0.27	21.6
						36	935.0000	0.076	0.62	12.2	0.47	16.2	0.28	27.0
						36	937.5000	0.093	0.63	14.8	0.47	19.8	0.28	33.0
					4	4	939.0000	0.083	0.63	13.3	0.47	17.8	0.28	29.6
						4	901.5000	0.006	0.60	1.0	0.45	1.4	0.27	2.3
					4	940.5000	0.010	0.63	1.5	0.47	2.0	0.28	3.3	

**Table 11**

MPE assessment for LMR 8900MHz - roof mounted antenna – Passenger Back

Trunk/ Roof	Test Position	E/H Field	Angle (Degree)	Antenna Model	Max Pwr (W)	Initial Pwr (W)	Tx Freq (MHz)	Max Calc. P.D. (mW/ cm <sup>2</sup> )	FCC Limit	% To FCC Spec Limit	ICNIRP Limit	% To ICNIRP Spec Limit	ISED Limit	% To ISED Spec Limit
Roof	PB	E	0	HAF4013A, 806-941MHz	42	42	806.0000	0.015	0.54	2.8	0.40	3.7	0.25	5.9
						42	815.0000	0.011	0.54	1.9	0.41	2.6	0.26	4.1
						42	824.0000	0.005	0.55	0.8	0.41	1.1	0.26	1.8
						42	851.0000	0.006	0.57	1.1	0.43	1.5	0.26	2.4
						42	860.0000	0.009	0.57	1.6	0.43	2.1	0.27	3.4
						42	869.0000	0.007	0.58	1.2	0.43	1.6	0.27	2.6
					36	36	896.0000	0.008	0.60	1.3	0.45	1.7	0.27	2.8
						36	898.5000	0.006	0.60	1.1	0.45	1.4	0.27	2.3
						36	900.0000	0.007	0.60	1.1	0.45	1.5	0.27	2.5
						36	935.0000	0.004	0.62	0.7	0.47	0.9	0.28	1.5
						36	937.5000	0.004	0.63	0.6	0.47	0.8	0.28	1.3
						36	939.0000	0.003	0.63	0.5	0.47	0.7	0.28	1.2
	4	4	901.5000	0.001	0.60	0.1	0.45	0.2	0.27	0.3				
		4	940.5000	0.001	0.63	0.1	0.47	0.1	0.28	0.2				
	E	0	HAF4036A, 806-941MHz	42	42	806.0000	0.015	0.54	2.8	0.40	3.7	0.25	5.9	
					42	815.0000	0.015	0.54	2.8	0.41	3.7	0.26	6.0	
					42	824.0000	0.010	0.55	1.8	0.41	2.3	0.26	3.7	
					42	851.0000	0.007	0.57	1.3	0.43	1.7	0.26	2.8	
					42	860.0000	0.010	0.57	1.7	0.43	2.3	0.27	3.7	
					42	869.0000	0.009	0.58	1.5	0.43	2.0	0.27	3.3	
				36	36	896.0000	0.008	0.60	1.3	0.45	1.8	0.27	2.9	
					36	898.5000	0.007	0.60	1.2	0.45	1.6	0.27	2.7	
					36	900.0000	0.008	0.60	1.3	0.45	1.8	0.27	2.9	
					36	935.0000	0.006	0.62	0.9	0.47	1.3	0.28	2.1	
36					937.5000	0.004	0.63	0.6	0.47	0.8	0.28	1.3		
36					939.0000	0.003	0.63	0.5	0.47	0.6	0.28	1.0		
4	4	901.5000	0.001	0.60	0.1	0.45	0.1	0.27	0.2					
	4	940.5000	0.001	0.63	0.1	0.47	0.1	0.28	0.2					

**Table 11 (Continued)**

**MPE assessment for LMR 8900MHz - roof mounted antenna – Passenger Back**

Results highlight in Bold are configurations with highest percentage of limits

Trunk/ Roof	Test Position	E/H Field	Angle (Degree)	Antenna Model	Max Pwr (W)	Initial Pwr (W)	Tx Freq (MHz)	Max Calc. P.D. (mW/ cm <sup>2</sup> )	FCC Limit	% To FCC Spec Limit	ICNIRP Limit	% To ICNIRP Spec Limit	ISED Limit	% To ISED Spec Limit
Roof	PB	E	0	HAF4037A, 806-941MHz	42	42	806.0000	0.035	0.54	<b>6.4</b>	0.40	<b>8.6</b>	0.25	<b>13.6</b>
						42	815.0000	0.025	0.54	4.6	0.41	6.2	0.26	9.9
						42	824.0000	0.017	0.55	3.1	0.41	4.2	0.26	6.6
						42	851.0000	0.018	0.57	3.2	0.43	4.2	0.26	6.8
						42	860.0000	0.021	0.57	3.6	0.43	4.8	0.27	7.7
						42	869.0000	0.027	0.58	4.7	0.43	6.2	0.27	10.1
					36	36	896.0000	0.017	0.60	2.8	0.45	3.8	0.27	6.2
						36	898.5000	0.017	0.60	2.9	0.45	3.8	0.27	6.3
						36	900.0000	0.018	0.60	3.0	0.45	4.0	0.27	6.6
						36	935.0000	0.017	0.62	2.8	0.47	3.7	0.28	6.2
						36	937.5000	0.011	0.63	1.8	0.47	2.4	0.28	4.0
					4	4	939.0000	0.009	0.63	1.4	0.47	1.8	0.28	3.1
						4	901.5000	0.001	0.60	0.2	0.45	0.3	0.27	0.5
					4	940.5000	0.001	0.63	0.2	0.47	0.2	0.28	0.4	

**Table 12**

MPE assessment for LMR 8900MHz - trunk mounted antenna – Passenger Front

Trunk/ Roof	Test Position	E/H Field	Angle (Degree)	Antenna Model	Max Pwr (W)	Initial Pwr (W)	Tx Freq (MHz)	Max Calc. P.D. (mW/ cm <sup>2</sup> )	FCC Limit	% To FCC Spec Limit	ICNIRP Limit	% To ICNIRP Spec Limit	ISED Limit	% To ISED Spec Limit
Trunk	PF	E	0	HAF4013A, 806-941MHz	42	42	806.0000	0.053	0.54	9.9	0.40	13.2	0.25	21.0
						42	815.0000	0.056	0.54	10.3	0.41	13.7	0.26	21.8
						42	824.0000	0.055	0.55	10.1	0.41	13.5	0.26	21.5
						42	851.0000	0.039	0.57	6.8	0.43	9.1	0.26	14.6
						42	860.0000	0.043	0.57	7.4	0.43	9.9	0.27	16.0
						42	869.0000	0.023	0.58	3.9	0.43	5.2	0.27	8.5
					36	36	896.0000	0.033	0.60	5.5	0.45	7.4	0.27	12.1
						36	898.5000	0.035	0.60	5.9	0.45	7.8	0.27	12.9
						36	900.0000	0.030	0.60	5.0	0.45	6.7	0.27	11.1
						36	935.0000	0.026	0.62	4.2	0.47	5.6	0.28	9.3
						36	937.5000	0.019	0.63	3.0	0.47	4.0	0.28	6.6
						36	939.0000	0.021	0.63	3.4	0.47	4.5	0.28	7.5
					4	4	901.5000	0.002	0.60	0.4	0.45	0.5	0.27	0.8
						4	940.5000	0.001	0.63	0.2	0.47	0.3	0.28	0.4
			0	HAF4036A, 806-941MHz	42	42	806.0000	0.052	0.54	9.7	0.40	13.0	0.25	20.6
						42	815.0000	0.051	0.54	9.4	0.41	12.5	0.26	19.9
						42	824.0000	0.061	0.55	11.0	0.41	14.7	0.26	23.5
						42	851.0000	0.038	0.57	6.8	0.43	9.0	0.26	14.6
						42	860.0000	0.034	0.57	5.9	0.43	7.9	0.27	12.8
						42	869.0000	0.034	0.58	5.8	0.43	7.7	0.27	12.6
36	36	896.0000			0.034	0.60	5.8	0.45	7.7	0.27	12.6			
	36	898.5000			0.036	0.60	6.1	0.45	8.1	0.27	13.3			
	36	900.0000			0.026	0.60	4.3	0.45	5.8	0.27	9.5			
	36	935.0000			0.017	0.62	2.7	0.47	3.5	0.28	5.9			
	36	937.5000			0.017	0.63	2.7	0.47	3.7	0.28	6.1			
	36	939.0000			0.012	0.63	2.0	0.47	2.6	0.28	4.4			
4	4	901.5000			0.002	0.60	0.3	0.45	0.4	0.27	0.7			
	4	940.5000			0.001	0.63	0.1	0.47	0.2	0.28	0.3			

**Table 12 (continued)**

MPE assessment for LMR 8900MHz - trunk mounted antenna – Passenger Front

Results highlight in Bold are configurations with highest percentage of limits

Trunk/ Roof	Test Position	E/H Field	Angle (Degree)	Antenna Model	Max Pwr (W)	Initial Pwr (W)	Tx Freq (MHz)	Max Calc. P.D. (mW/ cm <sup>2</sup> )	FCC Limit	% To FCC Spec Limit	ICNIRP Limit	% To ICNIRP Spec Limit	ISED Limit	% To ISED Spec Limit
Trunk	PF	E	0	HAF4037A, 806-941MHz	42	42	806.0000	0.107	0.54	20.0	0.40	26.7	0.25	42.3
						42	815.0000	0.116	0.54	21.3	0.41	28.4	0.26	45.2
						42	824.0000	0.133	0.55	<b>24.2</b>	0.41	<b>32.3</b>	0.26	<b>51.7</b>
						42	851.0000	0.059	0.57	10.4	0.43	13.9	0.26	22.4
						42	860.0000	0.047	0.57	8.2	0.43	11.0	0.27	17.8
						42	869.0000	0.043	0.58	7.3	0.43	9.8	0.27	15.9
					36	36	896.0000	0.049	0.60	8.2	0.45	10.9	0.27	17.9
						36	898.5000	0.051	0.60	8.6	0.45	11.4	0.27	18.8
						36	900.0000	0.050	0.60	8.3	0.45	11.0	0.27	18.1
						36	935.0000	0.047	0.62	7.6	0.47	10.1	0.28	16.9
						36	937.5000	0.039	0.63	6.2	0.47	8.2	0.28	13.7
						36	939.0000	0.040	0.63	6.3	0.47	8.4	0.28	14.1
					4	4	901.5000	0.004	0.60	0.7	0.45	1.0	0.27	1.7
						4	940.5000	0.003	0.63	0.5	0.47	0.7	0.28	1.1

**Table 13**

MPE assessment for LMR 8900MHz - roof mounted antenna – Passenger Front

Trunk/ Roof	Test Position	E/H Field	Angle (Degree)	Antenna Model	Max Pwr (W)	Initial Pwr (W)	Tx Freq (MHz)	Max Calc. P.D. (mW/ cm <sup>2</sup> )	FCC Limit	% To FCC Spec Limit	ICNIRP Limit	% To ICNIRP Spec Limit	ISED Limit	% To ISED Spec Limit
Roof	PF	E	0	HAF4013A, 806-941MHz	42	42	806.0000	0.011	0.54	2.0	0.40	2.7	0.25	4.3
						42	815.0000	0.006	0.54	1.2	0.41	1.6	0.26	2.5
						42	824.0000	0.006	0.55	1.1	0.41	1.5	0.26	2.4
						42	851.0000	0.004	0.57	0.8	0.43	1.0	0.26	1.7
						42	860.0000	0.004	0.57	0.7	0.43	0.9	0.27	1.4
						42	869.0000	0.004	0.58	0.7	0.43	0.9	0.27	1.5
					36	36	896.0000	0.007	0.60	1.2	0.45	1.6	0.27	2.6
						36	898.5000	0.004	0.60	0.7	0.45	0.9	0.27	1.5
						36	900.0000	0.006	0.60	0.9	0.45	1.2	0.27	2.0
						36	935.0000	0.004	0.62	0.6	0.47	0.8	0.28	1.4
						36	937.5000	0.002	0.63	0.4	0.47	0.5	0.28	0.9
						36	939.0000	0.003	0.63	0.4	0.47	0.6	0.28	0.9
					4	4	901.5000	0.000	0.60	0.1	0.45	0.1	0.27	0.1
						4	940.5000	0.000	0.63	0.0	0.47	0.0	0.28	0.1
			0	HAF4036A, 806-941MHz	42	42	806.0000	0.014	0.54	2.5	0.40	3.4	0.25	5.4
						42	815.0000	0.008	0.54	1.4	0.41	1.9	0.26	3.0
						42	824.0000	0.006	0.55	1.1	0.41	1.4	0.26	2.3
						42	851.0000	0.003	0.57	0.5	0.43	0.7	0.26	1.2
						42	860.0000	0.005	0.57	0.8	0.43	1.1	0.27	1.8
						42	869.0000	0.003	0.58	0.5	0.43	0.7	0.27	1.1
36	36	896.0000			0.007	0.60	1.1	0.45	1.5	0.27	2.4			
	36	898.5000			0.003	0.60	0.6	0.45	0.7	0.27	1.2			
	36	900.0000			0.004	0.60	0.7	0.45	0.9	0.27	1.5			
	36	935.0000			0.002	0.62	0.4	0.47	0.5	0.28	0.8			
	36	937.5000			0.004	0.63	0.6	0.47	0.8	0.28	1.3			
	36	939.0000			0.002	0.63	0.3	0.47	0.4	0.28	0.6			
4	4	901.5000			0.000	0.60	0.0	0.45	0.0	0.27	0.1			
	4	940.5000			0.000	0.63	0.0	0.47	0.0	0.28	0.1			



**Table 13 (continued)**

**MPE assessment for LMR 8900MHz - trunk mounted antenna – Passenger Front**

Results highlight in Bold are configurations with highest percentage of limits

Trunk/ Roof	Test Position	E/H Field	Angle (Degree)	Antenna Model	Max Pwr (W)	Initial Pwr (W)	Tx Freq (MHz)	Max Calc. P.D. (mW/ cm^2)	FCC Limit	% To FCC Spec Limit	ICNIRP Limit	% To ICNIRP Spec Limit	ISED Limit	% To ISED Spec Limit
Roof	PF	E	0	HAF4037A, 806-941MHz	42	42	806.0000	0.025	0.54	<b>4.6</b>	0.40	<b>6.2</b>	0.25	<b>9.8</b>
						42	815.0000	0.021	0.54	3.9	0.41	5.3	0.26	8.4
						42	824.0000	0.013	0.55	2.4	0.41	3.2	0.26	5.1
						42	851.0000	0.011	0.57	2.0	0.43	2.6	0.26	4.2
						42	860.0000	0.017	0.57	3.0	0.43	4.0	0.27	6.5
						42	869.0000	0.013	0.58	2.2	0.43	2.9	0.27	4.8
					36	36	896.0000	0.015	0.60	2.5	0.45	3.4	0.27	5.6
						36	898.5000	0.013	0.60	2.1	0.45	2.8	0.27	4.6
						36	900.0000	0.012	0.60	1.9	0.45	2.6	0.27	4.2
						36	935.0000	0.011	0.62	1.8	0.47	2.4	0.28	3.9
						36	937.5000	0.008	0.63	1.3	0.47	1.7	0.28	2.9
					4	4	939.0000	0.010	0.63	1.7	0.47	2.2	0.28	3.7
						4	901.5000	0.001	0.60	0.1	0.45	0.2	0.27	0.3
					4	940.5000	0.001	0.63	0.1	0.47	0.2	0.28	0.3	

## 17.2 MPE Test Results for Bluetooth and WLAN

Antenna PMAN5100A and PMAN5101A was intended for mounting on the windshield of the vehicle. These antennas should be installed close to the top, and on the front windshield only. Antennas AN000163A01 and AN000163A05 support WLAN 2.4 GHz / 5 GHz should be installed at roof or trunk of the vehicle. WLAN 2.4 GHz and 5 GHz will not transmit simultaneously.

MPE calculation was use to determine power density for these transmitters due to lower power. According to FCC's OET Bulletin 65 Edition 97-01 Section 2, calculations can be made to predict RF field strength and power density levels around typical RF sources. Equation (5) is generally accurate in far-field of an antenna.

$$S = \frac{P_t G}{4\pi d^2} F \quad (5)$$

Equation (5) accounts for the maximum duty cycle of the signal, and the factor, F, to provide a conservative power density prediction per FCC OET Bulletin 65, Edition 97-01 1997.

Where:

- S = power density
- $P_t$  = maximum output power scaled by the maximum duty cycle of the signal
- G = power gain of the antenna in the direction of interest relative to an isotropic radiator
- d = distance from antenna
- F = Enhancement factor [1 or 2.56 for predicting ground-level field strength]

Table 14 summarized the MPE calculation for each standalone transmitter bands, Bluetooth and WLAN.

**Table 14**

Antenna #	Max Power (W)	Duty Cycle (%)	Tx Frequency (MHz)	Antenna Gain (dBi)	Cable Loss, L (dB)	Dist., d (cm)	<sup>(4)</sup> Enhance Factor, F	Max Calc. MPE (mW/cm <sup>2</sup> )	MPE Spec Limit (mW/cm <sup>2</sup> )					
									FCC	% To FCC Spec Limit	ICNIRP	% To ICNIRP Spec Limit	ISED limit	% To ISED Spec Limit
<b>WLAN 2.4 GHz</b>														
AN000163A01	0.040	100%	2412.0	3.50	0.00	20	1.00	0.018	1.00	1.77	1.00	1.77	0.54	3.30
AN000163A01	0.040	100%	2437.0	3.50	0.00	20	1.00	0.018	1.00	1.77	1.00	1.77	0.54	3.28
AN000163A01	0.040	100%	2462.0	3.50	0.00	20	1.00	0.018	1.00	1.77	1.00	1.77	0.54	3.26
AN000163A05	0.040	100%	2412.0	2.50	0.00	20	1.00	0.014	1.00	1.41	1.00	1.41	0.54	2.62
AN000163A05	0.040	100%	2437.0	2.50	0.00	20	1.00	0.014	1.00	1.41	1.00	1.41	0.54	2.61
AN000163A05	0.040	100%	2462.0	2.50	0.00	20	1.00	0.014	1.00	1.41	1.00	1.41	0.54	2.59
PMAN5100A	0.040	100%	2412.0	3.00	0.00	20	1.00	0.016	1.00	1.58	1.00	1.58	0.54	2.94
PMAN5100A	0.040	100%	2437.0	3.00	0.00	20	1.00	0.016	1.00	1.58	1.00	1.58	0.54	2.92
PMAN5100A	0.040	100%	2462.0	3.00	0.00	20	1.00	0.016	1.00	1.58	1.00	1.58	0.54	2.90
PMAN5101A	0.040	100%	2412.0	2.70	0.00	20	1.00	0.015	1.00	1.47	1.00	1.47	0.54	2.75
PMAN5101A	0.040	100%	2437.0	2.70	0.00	20	1.00	0.015	1.00	1.47	1.00	1.47	0.54	2.73
PMAN5101A	0.040	100%	2462.0	2.70	0.00	20	1.00	0.015	1.00	1.47	1.00	1.47	0.54	2.71
<b>WLAN 5 GHz</b>														
AN000163A01	0.016	100%	5180.0	3.30	0.00	20	1.00	0.007	1.00	0.67	1.00	0.67	0.90	0.75
AN000163A01	0.016	100%	5502.5	3.30	0.00	20	1.00	0.007	1.00	0.67	1.00	0.67	0.94	0.71
AN000163A01	0.016	100%	5825.0	3.30	0.00	20	1.00	0.007	1.00	0.67	1.00	0.67	0.98	0.69
AN000163A05	0.016	100%	5180.0	1.60	0.00	20	1.00	0.005	1.00	0.46	1.00	0.46	0.90	0.50
AN000163A05	0.016	100%	5502.5	1.60	0.00	20	1.00	0.005	1.00	0.46	1.00	0.46	0.94	0.48
AN000163A05	0.016	100%	5825.0	1.60	0.00	20	1.00	0.005	1.00	0.46	1.00	0.46	0.98	0.46
PMAN5101A	0.016	100%	5180.0	0.20	0.00	20	1.00	0.003	1.00	0.33	1.00	0.33	0.90	0.36
PMAN5101A	0.016	100%	5502.5	0.20	0.00	20	1.00	0.003	1.00	0.33	1.00	0.33	0.94	0.35
PMAN5101A	0.016	100%	5825.0	0.20	0.00	20	1.00	0.003	1.00	0.33	1.00	0.33	0.98	0.34
<b>Bluetooth 2.4 GHz</b>														
AN000163A01	0.011	100%	2402.0	3.50	0.00	20	1.00	0.005	1.00	0.50	1.00	0.50	0.54	0.93
AN000163A01	0.011	100%	2441.0	3.50	0.00	20	1.00	0.005	1.00	0.50	1.00	0.50	0.54	0.92
AN000163A01	0.011	100%	2480.0	3.50	0.00	20	1.00	0.005	1.00	0.50	1.00	0.50	0.55	0.91
AN000163A05	0.011	100%	2402.0	2.50	0.00	20	1.00	0.004	1.00	0.40	1.00	0.40	0.54	0.74
AN000163A05	0.011	100%	2441.0	2.50	0.00	20	1.00	0.004	1.00	0.40	1.00	0.40	0.54	0.73
AN000163A05	0.011	100%	2480.0	2.50	0.00	20	1.00	0.004	1.00	0.40	1.00	0.40	0.55	0.73
PMAN5100A	0.011	100%	2402.0	3.00	0.00	20	1.00	0.004	1.00	0.45	1.00	0.45	0.54	0.83
PMAN5100A	0.011	100%	2441.0	3.00	0.00	20	1.00	0.004	1.00	0.45	1.00	0.45	0.54	0.82
PMAN5100A	0.011	100%	2480.0	3.00	0.00	20	1.00	0.004	1.00	0.45	1.00	0.45	0.55	0.81
PMAN5101A	0.011	100%	2402.0	2.70	0.00	20	1.00	0.004	1.00	0.42	1.00	0.42	0.54	0.78
PMAN5101A	0.011	100%	2441.0	2.70	0.00	20	1.00	0.004	1.00	0.42	1.00	0.42	0.54	0.77
PMAN5101A	0.011	100%	2480.0	2.70	0.00	20	1.00	0.004	1.00	0.42	1.00	0.42	0.55	0.76

Notes:

- 1) Distance from antenna (d), 20cm for more conservative estimation.
- 2) Cable loss (L), all cable loss include in antenna gain, so should be 0 dB.
- 3) Enhancement Factor (F), 1 (Ground reflection already factor in during antenna characterization)

### 17.3 Simultaneous Transmission

LMR bands can transmit simultaneously with Bluetooth or WLAN 2.4 GHz or WLAN 5 GHz. Bluetooth and WLAN 2.4 GHz or WLAN 5 GHz transmitters cannot transmit at the same time.

The highest percentage of limit for each standalone transmitters indicated in Table 15.

**Table 15**

Transmitters	Frequency Band (MHz)	Highest Percentage of Limit (%)		
		Passenger, Front Seat (PF)	Passenger, Back Seat (PB)	Bystander (BS)
<b>FCC US</b>				
LMR 8/900MHz	806-824, 851-869, 896-901, 935-940	24.2 %	38.9 %	19.9 %
Bluetooth	2402 - 2480	0.50 %	0.50 %	0.50 %
WLAN 2.4 GHz	2412 - 2462	1.77 %	1.77 %	1.77 %
WLAN 5 GHz	5180 - 5825	0.67 %	0.67 %	0.67 %
<b>ISED Canada</b>				
LMR 8/900MHz	806-824, 851-869, 896-901, 935-940	51.7 %	82.6 %	42.2 %
Bluetooth	2402 - 2480	0.93 %	0.93 %	0.93 %
WLAN 2.4 GHz	2412 - 2462	3.30 %	3.30 %	3.30 %
WLAN 5 GHz	5180 - 5825	0.75 %	0.75 %	0.75 %
<b>ICNIRP</b>				
LMR 8/900MHz	806-825, 851-870, 896-901, 935-940	32.3 %	51.8 %	26.5 %
Bluetooth	2402 - 2480	0.50 %	0.50 %	0.50 %
WLAN 2.4 GHz	2412 - 2462	1.77 %	1.77 %	1.77 %
WLAN 5 GHz	5180 - 5825	0.67 %	0.67 %	0.67 %

Per KDB 447498 D01, simultaneous transmission MPE test exclusion applies when the sum of MPE ratios for all simultaneous transmitting antennas incorporated in a host device is  $\leq 1.0$ , according to calculated/estimated, numerically modeled, or measured field strengths or power density.

Calculated Maximum Power density for WLAN 2.4 GHz is greater than WLAN 5 GHz and Bluetooth. WLAN 2.4 GHz, WLAN 5 GHz and Bluetooth transmitters cannot transmit at the same time. Thus, WLAN 2.4 GHz will be used to evaluate simultaneous transmission test exclusion. The highest combined power density percentage for simultaneous transmission indicated in Table 16.

**Table 16**

Designator	Simultaneous Transmission Scenario	Highest Combined Percentage of Limit (%)		
		Passenger, Front Seat (PF)	Passenger, Back Seat (PB)	Bystander (BS)
FCC US	LMR 8/900MHz and WLAN	26.0 %	40.7 %	21.7 %
ISED Canada	LMR 8/900MHz and WLAN	55.0 %	85.9 %	45.5 %
ICNIRP	LMR 8/900MHz and WLAN	34.1 %	53.6 %	28.3 %

**18.0 Conclusion**

The assessments for this device were performed with an output power range as indicated in Section 17.1 (for LMR) and 17.2 (for BT/WLAN). The maximum allowable output power is equal to the upper limit of the final test factory transmit power specification listed in Table 6. The highest power density results for LMR and BT/WLAN transmitters scaled to maximum allowable power output are indicated in Table 17 and 18 for internal/passenger to the vehicle, and external/bystander to the vehicle.

**Table 17: Maximum MPE RF Exposure Summary (LMR)**

Designator	Transmitters	Frequency Band (MHz)	Passenger (mW/cm <sup>2</sup> )	Bystander (mW/cm <sup>2</sup> )
FCC US	LMR 8/900MHz	806-824, 851-869, 896-901, 935-940	0.211	0.107
ISED Canada	LMR 8/900MHz	806-824, 851-869, 896-901, 935-940	0.211	0.107
ICNIRP	LMR 8/900MHz	806-825, 851-870, 896-901, 935-940	0.211	0.107

**Table 18: Maximum MPE RF Exposure Summary (BT/WLAN)**

Designator	Transmitters	Frequency Band (MHz)	Passenger (mW/cm <sup>2</sup> )	Bystander (mW/cm <sup>2</sup> )
FCC US / ISED Canada / ICNIRP	Bluetooth	2402-2480	0.005	0.005
	WLAN	2412-2462	0.018	0.018
	WLAN	5180-5825	0.007	0.007

These MPE results herein demonstrate compliance to the FCC US, ISED Canada and ICNIRP Occupational/Controlled Exposure limit. FCC rules require compliance for Passengers and Bystanders to the FCC General Population/Uncontrolled limits.

**19.0 User Instructions Considerations**

In order to facilitate the task of professional users, the Safety Manual for this radio requires that bystanders be kept at least 2 ft (60 cm) from the vehicle Body.

### Appendix A - Antenna Locations, Test Distances, and Cable Losses

Antenna locations

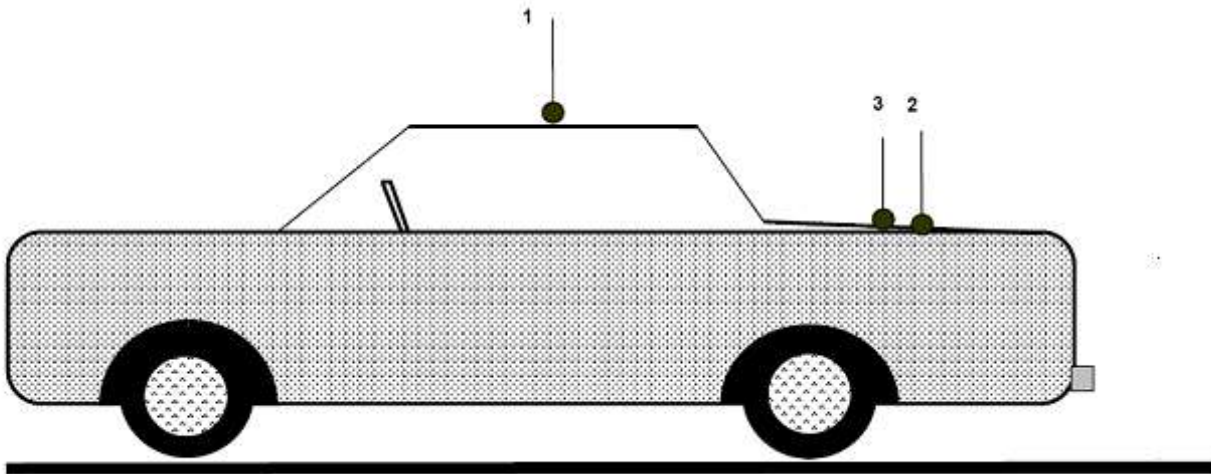

1. Roof (20cm from center)
2. Trunk (85cm from back of the back seat)
3. Trunk (center)

### Passenger Antenna mounting (8/900MHz)

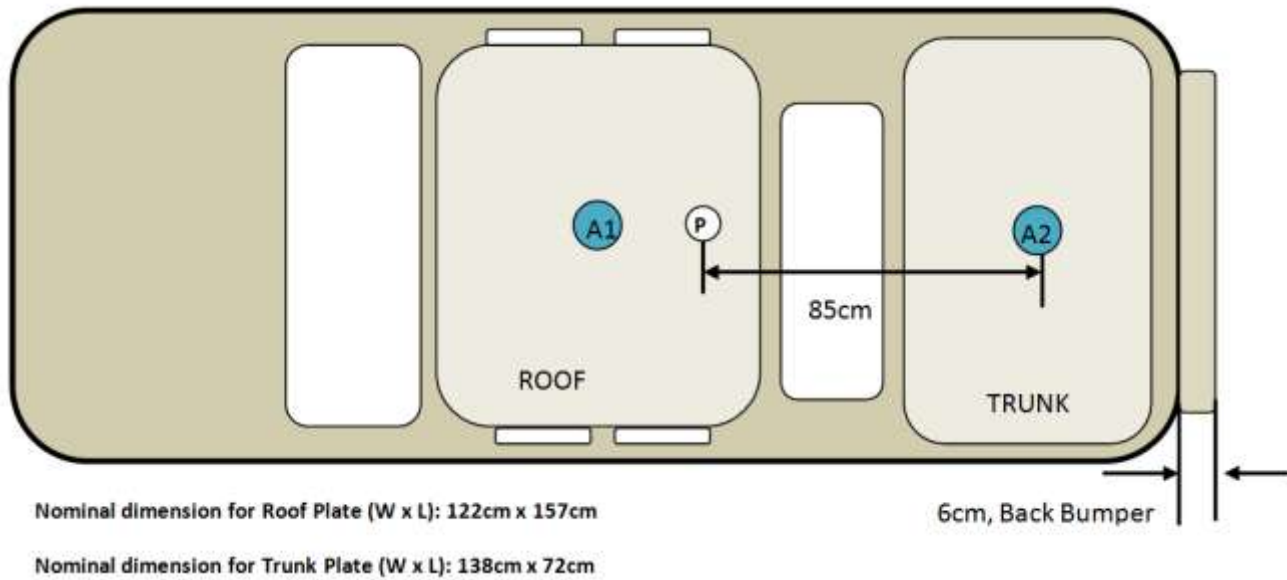

Notes:

- 1.) Antenna location A1: APX 6500 mobile radio roof antenna mounting locations for front and back passenger testing (8/900MHz)
- 2.) Antenna location A2: APX 6500 mobile trunk antenna mounting locations for front and back passenger testing (8/900MHz)
- 3.) Total distance between trunk mount antenna and rear passenger is 85cm.

### Bystander Antenna mounting (8/900MHz)

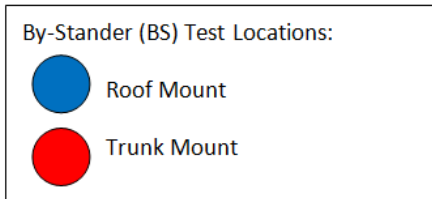
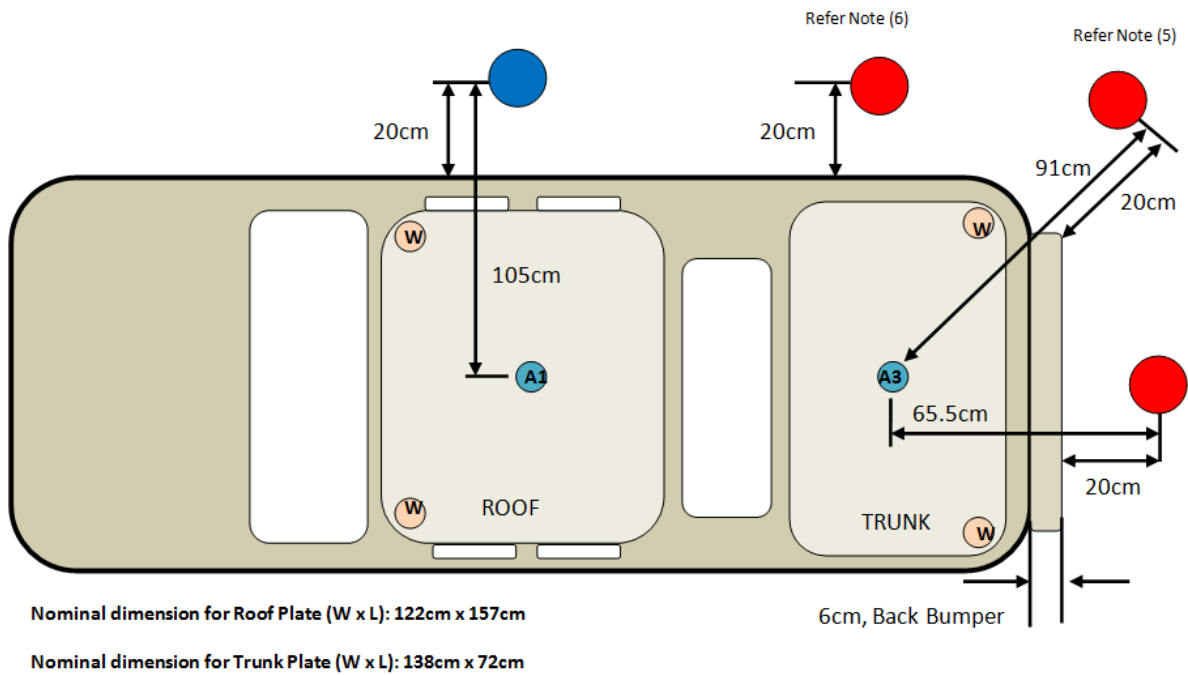

Notes:

- 1) Antenna location A1: APX 6500 mobile radio roof antenna mounting location.
- 2) Antenna location A3: APX 6500 mobile radio trunk antenna mounting location for bystander testing.
- 3) Antenna locations W: Four total locations identified for BT/WLAN/WWAN antenna mounting. (if LMR antennas installed at trunk, BT/WLAN/WWAN antennas should be installed on the roof and vice versa).
- 4) Total distance between Bystander 45 degree angles from the centered-trunk mount antenna is 91cm to maintain a minimum 20cm separation between probe sensor and vehicle body.
- 5) Total distance between Bystander 90 degree angle from the centered-trunk mount antenna is 60cm (by moving antenna location A3 42cm from center of the trunk).



### Seat scan areas (Applicable to both front and back seats)

Meter - Probe

 Probe diameter is 5.5cm

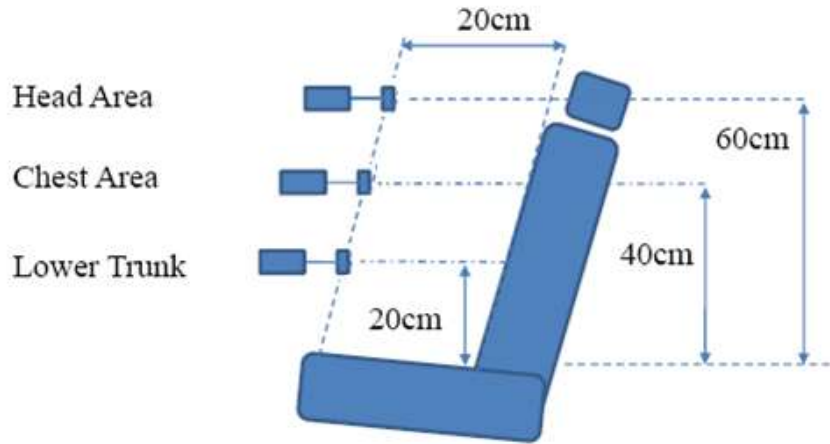

## Cable Losses

### **Test Cable**

#### Teflon RG58A/U Loss Per 100 Feet

160 MHz - 5 dB

450 MHz - 9 dB

1 GHz - 13.8 dB

### **Customer Cable**

#### RG-58A/U Loss Per 100 Feet (For LMR)

136 MHz – 5.5 dB

450 MHz – 9.6 dB

900 MHz – 13.9 dB

#### PFP 240 Loss Per 100 Feet (For BT/WLAN)

2500 MHz - 12.9 dB

5800 MHz -20.4 dB

### Appendix B - Probe Calibration Certificates

**Service Test Report**  
QAF 1126, 03/11  
Report ID: 134653



#### Certificate of Test Conformance Page 1 of 1

**Reference:** S 000048638

**Customer:** Motorola Solutions Malaysia Sdn Bhd - Plot 2A, Medan Bayan Lepas, Mukim 12  
S.W.D. - Bayan Lepas - Penang 11900 - Malaysia

The instrument listed below has been tested and verified to Internal Quality Standards. Test data is Attached. Equipment used during instrument testing is controlled by laboratory compliance with ISO/IEC 17025-2017 and ANSI/NCSL Z540-1-1994 using ETS-Lindgren Quality Management System internal procedures.

<b><u>Manufacturer</u></b>	ETS-Lindgren	<b><u>Status In</u></b>	In Tolerance
<b><u>Instrument Type</u></b>	RF Survey Meter	<b><u>Date Completed</u></b>	06-May-20
<b><u>Model</u></b>	HI-2200	<b><u>Status Out</u></b>	Compliant with Internal Quality Standards
<b><u>Serial Number/ID</u></b>	00086887		

**Remarks**

Performed functional test with E100 sn 00224511 and H200 sn 00224521. Unit had Firmware #2.32 Upgrade. Alt ID: MS10201.

I would like to take this opportunity to express our appreciation for using ETS-Lindgren for your EMI test equipment services and I am looking forward to continued business with your organization. Please feel free to contact our offices at (512) 531-6400, if you have any questions regarding this report.

Sincerely,  
  
George Cisneros  
Calibration Supervisor

**Date Attested:** 06-May-20



Cert I.D.: 134651

Certificate of Calibration Conformance

Page 1 of 3

The instrument identified below has been individually calibrated in compliance with the following standard(s):

IEEE 1309 - 2013, Institute of Electrical and Electronics Engineers, Standard for Calibration of Electromagnetic Field Sensors and Probes, Excluding Antennas from 9 kHz to 40 GHz

Environment: Laboratory MTE is maintained in a temperature controlled environment with ambient conditions from 18 to 28 C, relative humidity less than 90%. The instrument under test has been calibrated in a suitable environment using an EMCO TEM Cell 5101C, GTEM 5305/5402 and an RF Shielded EMC Chamber which is conducive to maintaining accurate and reliable measurement quality.

Manufacturer: ETS-Lindgren Operating Range: 100kHz - 5GHz
Model Number: E100 Instrument Type: Isotropic Probe > 1 GHz
Serial Number/ ID: 00224511 Date Code:
Tracking Number: S 000048638 Alternate ID: MS10428
Date Completed: 06-May-20 Customer: Motorola Solutions Malaysia Sdn Bhd - Plot 2A, Medan Bayan Lepas, Mukim 12 S.W.D. - Bayan Lepas - Penang 11900 - Malaysia
Test Type: Standard Field, Field Strength

Calibration Uncertainty: Std Field Method 100kHz - 6 GHz, +/-0.64 dB, Linearity +/- 0.95 dB, isotropicity +/- 0.86
k=2, (95% Confidence Level)

Test Remarks: Probe received in tolerance thus before and after data are the same. Calibration performed with customer's HI-2200 sn 00066887.

Calibration Traceability: All Measuring and Test Equipment (M/TE) identified below are traceable to the SI units through the National Institute for Standards and Technology (NIST) or other recognized National Metrology Institute. Calibration Laboratory and Quality System controls are compliant with ISO/IEC 17025:2017 and ANSI/NCSL Z540-1-1994.

Standards and Equipment Used:

Table with columns: Make / Model / Name / S/N / Calibration Date. Lists various equipment including HP, Keysight, Hewlett Packard, Agilent, Rohde & Schwarz, Marconi, and Keysight with their respective S/N and calibration dates.

Condition of Instrument

Upon Receipt: In Tolerance to Internal Quality Standards
On Release: In Tolerance to Internal Quality Standards

Calibration Completed By: Julio A. Aquino, Calibration Technician

Attested and Issued on 06-May-20
George Camero, Calibration Supervisor

This document provides traceability of measurements to recognized national standards using controlled processes at the ETS-Lindgren Calibration Laboratory. Uncertainties listed are derived from the methods described by NIST Tech Note 1297. This certificate and report may not be reproduced, except in full, without the written approval of ETS-Lindgren Calibration Laboratory in accordance with ISO/IEC 17025:2017 and ANSI/NCSL Z540-1-1994. The results in this document relate only to the item(s) listed and should not be considered representative of a population unless otherwise noted. QAF 1127 (03/11)

### CALIBRATION REPORT

**Electric Field Sensor**

<i>Model</i>	<i>S/N</i>
E100	00224511
HI-2200	00086887

Date: 06 May 2020

- New Instrument
- Other
- Out of Tolerance
- Within Tolerance

**Frequency Response**

<i>Frequency Response</i>	<i>MHz</i>	<i>Nominal Field</i> <i>V/m</i>	<i>Cal Factor*</i> <i>(Applied/Indicated)</i>	<i>Deviation</i> <i>dB</i>
1	0.1	20	1.45	-3.22
2	0.5	20	1.12	-1.01
3	1	20	1.05	-0.43
4	3	20	1.00	-0.03
5	15	20	1.00	0.00
6	27.12	20	1.01	-0.05
7	30	20	1.00	-0.04
8	75	20	1.01	-0.07
9	100	20	1.01	-0.11
10	150	20	1.01	-0.10
11	200	20	1.00	-0.03
12	250	20	1.00	-0.04
13	300	20	0.99	0.08
14	400	20	1.01	-0.05
15	500	20	1.05	-0.46
16	600	20	1.05	-0.43
17	700	20	1.08	-0.65
18	800	20	1.10	-0.81
19	900	20	1.05	-0.39
20	1000	20	1.00	0.00
21	2000	20	1.04	-0.32
22	2450	20	1.04	-0.38
23	3000	20	0.96	0.39
24	3500	20	0.90	0.91
25	4000	20	0.99	0.10
26	5000	20	1.01	-0.08
27	5500	20	1.25	-1.93
28	6000	20	1.33	-2.47

\* Corrected electric field values (V/m) can be obtained by multiplying the Cal Factor with the indicated E field readings.

**Linearity**

maximum linearity deviation is 0.42 dB  
(measurements taken from 0.3 V/m to 800 V/m at 27.12 MHz)

**Test Conditions**

Calibration performed at ambient room temperature: 23 ±3°C



### PROBE ROTATIONAL RESPONSE

Model E100  
S/N 00224511  
Report S00048638  
Date Date of Calibration 06 May 2020  
Time 08:45:13 AM  
Isotropy \* + 0.308 dB / -0.308 dB

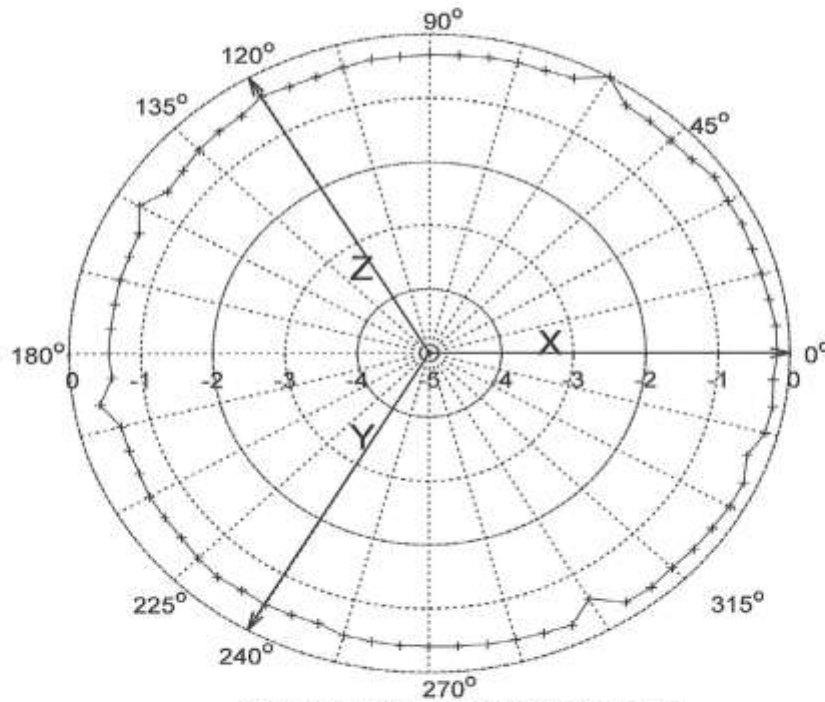

Figure 1: Probe Isotropic Response Chart.

Isotropic response is measured in a 20 V/m field at 400 MHz

\*Isotropy is the maximum deviation from the geometric mean as defined by IEEE 1309-2013.

**Appendix C - Photos of Assessed Antennas**  
(Refer to Exhibit 7B)

**Appendix D - MPE Measurement Results**



**Table D.1**  
**MPE Measurement Data for Bystander**

D.U.T. Info.										Probe Info.		MPE Measurements										DUT Max. TX Factor	Avg. over Body (mW/cm <sup>2</sup> )	Calc. P.D. (mW/cm <sup>2</sup> )	Max Calc. P.D. (mW/cm <sup>2</sup> )
Ant Loc.	Ant. Model/ Desc.	Ant. Gain (dBi)	Tx Freq (MHz)	Max Pwr (W)	Initial Pwr (W)	Test Mode	E/H Field	Probe Cal. Factor	Test Pos.	Bystander (BS) Positions															
										20 cm	40 cm	60 cm	80 cm	100 cm	120 cm	140 cm	160 cm	180 cm	200 cm						
Trunk	HAF4013A, 806-941MHz	5.15	806.0000	42.0	42	CW	E	1.20	BS	0.015	0.027	0.017	0.138	0.223	0.402	0.404	0.248	0.131	0.090	0.5	0.203	0.102	0.102		
Trunk	HAF4013A, 806-941MHz	5.15	815.0000	42.0	42	CW	E	1.19	BS	0.013	0.027	0.021	0.122	0.236	0.382	0.357	0.241	0.138	0.081	0.5	0.193	0.096	0.096		
Trunk	HAF4013A, 806-941MHz	5.15	824.0000	42.0	42	CW	E	1.18	BS	0.013	0.021	0.020	0.122	0.244	0.341	0.333	0.233	0.151	0.074	0.5	0.183	0.092	0.092		
Trunk	HAF4013A, 806-941MHz	5.15	851.0000	42.0	42	CW	E	1.15	BS	0.017	0.017	0.030	0.165	0.268	0.435	0.344	0.165	0.109	0.068	0.5	0.186	0.093	0.093		
Trunk	HAF4013A, 806-941MHz	5.15	860.0000	42.0	42	CW	E	1.14	BS	0.018	0.022	0.039	0.165	0.290	0.437	0.341	0.176	0.087	0.065	0.5	0.187	0.093	0.093		
Trunk	HAF4013A, 806-941MHz	5.15	869.0000	42.0	42	CW	E	1.14	BS	0.019	0.014	0.038	0.146	0.240	0.478	0.340	0.148	0.063	0.055	0.5	0.176	0.088	0.088		
Trunk	HAF4013A, 806-941MHz	5.15	896.0000	36.0	36	CW	E	1.11	BS	0.008	0.002	0.037	0.093	0.179	0.359	0.288	0.148	0.064	0.010	0.5	0.132	0.066	0.066		
Trunk	HAF4013A, 806-941MHz	5.15	898.5000	36.0	36	CW	E	1.10	BS	0.006	0.004	0.029	0.088	0.151	0.326	0.244	0.171	0.064	0.009	0.5	0.120	0.060	0.060		
Trunk	HAF4013A, 806-941MHz	5.15	900.0000	36.0	36	CW	E	1.10	BS	0.006	0.005	0.028	0.089	0.160	0.305	0.255	0.162	0.062	0.008	0.5	0.119	0.059	0.059		
Trunk	HAF4013A, 806-941MHz	5.15	935.0000	36.0	36	CW	E	1.07	BS	0.008	0.011	0.033	0.109	0.208	0.321	0.258	0.123	0.063	0.025	0.5	0.124	0.062	0.062		
Trunk	HAF4013A, 806-941MHz	5.15	937.5000	36.0	36	CW	E	1.06	BS	0.008	0.008	0.038	0.097	0.177	0.303	0.230	0.118	0.054	0.021	0.5	0.112	0.056	0.056		
Trunk	HAF4013A, 806-941MHz	5.15	939.0000	36.0	36	CW	E	1.06	BS	0.007	0.008	0.030	0.099	0.180	0.304	0.233	0.116	0.050	0.025	0.5	0.112	0.056	0.056		
Trunk	HAF4013A, 806-941MHz	5.15	901.5000	4.0	4	CW	E	1.10	BS	0.000	0.000	0.003	0.011	0.015	0.028	0.027	0.019	0.005	0.002	0.5	0.012	0.006	0.006		
Trunk	HAF4013A, 806-941MHz	5.15	940.5000	4.0	4	CW	E	1.06	BS	0.001	0.001	0.003	0.010	0.020	0.029	0.023	0.011	0.005	0.002	0.5	0.011	0.006	0.006		

MPE calculations are defined in Section 15.0

**Table D.1 (Continued)**  
**MPE Measurement Data for Bystander**

D.U.T. Info.							Probe Info.		MPE Measurements											DUT Max. TX Factor	Avg. over Body (mW/cm <sup>2</sup> )	Calc. P.D. (mW/cm <sup>2</sup> )	Max Calc. P.D. (mW/cm <sup>2</sup> )
Ant Loc.	Ant. Model/ Desc.	Ant. Gain (dBi)	Tx Freq (MHz)	Max Pwr (W)	Initial Pwr (W)	Test Mode	E/H Field	Probe Cal. Factor	Test Pos.	Bystander (BS) Positions													
										20 cm	40 cm	60 cm	80 cm	100 cm	120 cm	140 cm	160 cm	180 cm	200 cm				
Trunk	HAF4036A, 806-941MHz	2.14	806.0000	42.0	42	CW	E	1.20	BS	0.011	0.028	0.024	0.125	0.279	0.407	0.381	0.220	0.108	0.083	0.5	0.200	0.100	0.100
Trunk	HAF4036A, 806-941MHz	2.14	815.0000	42.0	42	CW	E	1.19	BS	0.016	0.028	0.023	0.131	0.242	0.352	0.327	0.211	0.113	0.066	0.5	0.180	0.090	0.090
Trunk	HAF4036A, 806-941MHz	2.14	824.0000	42.0	42	CW	E	1.18	BS	0.013	0.022	0.020	0.128	0.219	0.297	0.298	0.190	0.122	0.053	0.5	0.161	0.080	0.080
Trunk	HAF4036A, 806-941MHz	2.14	851.0000	42.0	42	CW	E	1.15	BS	0.013	0.016	0.032	0.129	0.225	0.362	0.296	0.134	0.074	0.050	0.5	0.153	0.077	0.077
Trunk	HAF4036A, 806-941MHz	2.14	860.0000	42.0	42	CW	E	1.14	BS	0.016	0.024	0.039	0.152	0.216	0.343	0.298	0.136	0.067	0.046	0.5	0.152	0.076	0.076
Trunk	HAF4036A, 806-941MHz	2.14	869.0000	42.0	42	CW	E	1.14	BS	0.017	0.010	0.033	0.138	0.214	0.371	0.301	0.115	0.042	0.036	0.5	0.146	0.073	0.073
Trunk	HAF4036A, 806-941MHz	2.14	896.0000	36.0	36	CW	E	1.11	BS	0.005	0.004	0.023	0.083	0.139	0.280	0.236	0.104	0.032	0.004	0.5	0.101	0.051	0.051
Trunk	HAF4036A, 806-941MHz	2.14	898.5000	36.0	36	CW	E	1.10	BS	0.004	0.004	0.028	0.085	0.138	0.231	0.189	0.120	0.037	0.005	0.5	0.093	0.046	0.046
Trunk	HAF4036A, 806-941MHz	2.14	900.0000	36.0	36	CW	E	1.10	BS	0.003	0.005	0.026	0.095	0.135	0.261	0.193	0.098	0.035	0.006	0.5	0.094	0.047	0.047
Trunk	HAF4036A, 806-941MHz	2.14	935.0000	36.0	36	CW	E	1.07	BS	0.007	0.011	0.030	0.094	0.166	0.282	0.204	0.078	0.036	0.012	0.5	0.098	0.049	0.049
Trunk	HAF4036A, 806-941MHz	2.14	937.5000	36.0	36	CW	E	1.06	BS	0.007	0.009	0.028	0.084	0.155	0.256	0.179	0.075	0.031	0.013	0.5	0.089	0.044	0.044
Trunk	HAF4036A, 806-941MHz	2.14	939.0000	36.0	36	CW	E	1.06	BS	0.007	0.007	0.030	0.086	0.147	0.245	0.173	0.071	0.028	0.013	0.5	0.086	0.043	0.043
Trunk	HAF4036A, 806-941MHz	2.14	901.5000	4.0	4	CW	E	1.10	BS	0.000	0.001	0.003	0.010	0.015	0.028	0.021	0.013	0.004	0.001	0.5	0.011	0.005	0.005
Trunk	HAF4036A, 806-941MHz	2.14	940.5000	4.0	4	CW	E	1.06	BS	0.001	0.001	0.003	0.009	0.019	0.026	0.019	0.003	0.003	0.001	0.5	0.009	0.005	0.005

MPE calculations are defined in Section 15.0

**Table D.1 (Continued)**  
**MPE Measurement Data for Bystander**

D.U.T. Info.							Probe Info.			MPE Measurements											DUT Max. TX Factor	Avg. over Body (mW/cm <sup>2</sup> )	Calc. P.D. (mW/cm <sup>2</sup> )	Max Calc. P.D. (mW/cm <sup>2</sup> )
Ant Loc.	Ant. Model/ Desc.	Ant. Gain (dBi)	Tx Freq (MHz)	Max Pwr (W)	Initial Pwr (W)	Test Mode	E/H Field	Probe Cal. Factor	Test Pos.	Bystander (BS) Positions														
										20 cm	40 cm	60 cm	80 cm	100 cm	120 cm	140 cm	160 cm	180 cm	200 cm					
Trunk	HAF4037A, 806-941MHz	3	806.0000	42.0	42	CW	E	1.20	BS	0.036	0.071	0.062	0.241	0.541	0.396	0.069	0.104	0.148	0.115	0.5	0.214	0.107	0.107	
Trunk	HAF4037A, 806-941MHz	3	815.0000	42.0	42	CW	E	1.19	BS	0.027	0.052	0.070	0.232	0.451	0.343	0.062	0.064	0.106	0.083	0.5	0.177	0.089	0.089	
Trunk	HAF4037A, 806-941MHz	3	824.0000	42.0	42	CW	E	1.18	BS	0.027	0.051	0.045	0.236	0.440	0.368	0.074	0.077	0.090	0.078	0.5	0.175	0.088	0.088	
Trunk	HAF4037A, 806-941MHz	3	851.0000	42.0	42	CW	E	1.15	BS	0.023	0.027	0.041	0.214	0.497	0.541	0.119	0.021	0.056	0.049	0.5	0.183	0.091	0.091	
Trunk	HAF4037A, 806-941MHz	3	860.0000	42.0	42	CW	E	1.14	BS	0.025	0.032	0.047	0.226	0.415	0.510	0.139	0.013	0.029	0.060	0.5	0.171	0.085	0.085	
Trunk	HAF4037A, 806-941MHz	3	869.0000	42.0	42	CW	E	1.14	BS	0.029	0.019	0.030	0.238	0.492	0.578	0.165	0.011	0.032	0.045	0.5	0.187	0.093	0.093	
Trunk	HAF4037A, 806-941MHz	3	896.0000	36.0	36	CW	E	1.11	BS	0.012	0.006	0.057	0.147	0.319	0.384	0.106	0.015	0.003	0.003	0.5	0.117	0.058	0.058	
Trunk	HAF4037A, 806-941MHz	3	898.5000	36.0	36	CW	E	1.10	BS	0.010	0.006	0.053	0.144	0.291	0.367	0.076	0.021	0.004	0.002	0.5	0.107	0.054	0.054	
Trunk	HAF4037A, 806-941MHz	3	900.0000	36.0	36	CW	E	1.10	BS	0.008	0.007	0.048	0.167	0.292	0.351	0.082	0.014	0.007	0.001	0.5	0.107	0.054	0.054	
Trunk	HAF4037A, 806-941MHz	3	935.0000	36.0	36	CW	E	1.07	BS	0.016	0.026	0.066	0.237	0.463	0.543	0.134	0.006	0.015	0.007	0.5	0.162	0.081	0.081	
Trunk	HAF4037A, 806-941MHz	3	937.5000	36.0	36	CW	E	1.06	BS	0.017	0.018	0.062	0.203	0.449	0.530	0.144	0.009	0.011	0.009	0.5	0.154	0.077	0.077	
Trunk	HAF4037A, 806-941MHz	3	939.0000	36.0	36	CW	E	1.06	BS	0.015	0.016	0.062	0.208	0.428	0.491	0.143	0.011	0.011	0.008	0.5	0.148	0.074	0.074	
Trunk	HAF4037A, 806-941MHz	3	901.5000	4.0	4	CW	E	1.10	BS	0.001	0.001	0.005	0.020	0.032	0.038	0.007	0.002	0.001	0.000	0.5	0.012	0.006	0.006	
Trunk	HAF4037A, 806-941MHz	3	940.5000	4.0	4	CW	E	1.06	BS	0.002	0.001	0.006	0.024	0.053	0.060	0.015	0.000	0.000	0.000	0.5	0.017	0.009	0.009	

MPE calculations are defined in Section 15.0

**Table D.1 (Continued)**  
**MPE measurement data for Bystander**

D.U.T. Info.							Probe Info.		MPE Measurements											DUT Max. TX Factor	Avg. over Body (mW/cm <sup>2</sup> )	Calc. P.D. (mW/cm <sup>2</sup> )	Max Calc. P.D. (mW/cm <sup>2</sup> )						
Ant Loc.	Ant. Model/ Desc.	Ant. Gain (dBi)	Tx Freq (MHz)	Max Pwr (W)	Initial Pwr (W)	Test Mode	E/H Field	Probe Cal. Factor	Test Pos.	Bystander (BS) Positions																			
										20 cm	40 cm	60 cm	80 cm	100 cm	120 cm	140 cm	160 cm	180 cm	200 cm										
<b>45 Degree</b>																													
Trunk	HAF4037A, 806-941MHz	3	806.0000	42.0	42	CW	E	1.20	BS	0.016	0.036	0.068	0.290	0.435	0.426	0.132	0.035	0.019	0.026	0.5	0.178	0.089	0.089						
<b>90 Degree</b>																													
Trunk	HAF4037A, 806-941MHz	3	806.0000	42.0	42	CW	E	1.20	BS	0.020	0.067	0.106	0.338	0.515	0.460	0.066	0.090	0.069	0.031	0.5	0.211	0.106	0.106						

MPE calculations are defined in Section 15.0

**Table D.1 (Continued)**  
**MPE measurement data for Bystander**

D.U.T. Info.							Probe Info.			MPE Measurements											DUT Max. TX Factor	Avg. over Body (mW/cm <sup>2</sup> )	Calc. P.D. (mW/cm <sup>2</sup> )	Max Calc. P.D. (mW/cm <sup>2</sup> )
Ant Loc.	Ant. Model/ Desc.	Ant. Gain (dBi)	Tx Freq (MHz)	Max Pwr (W)	Initial Pwr (W)	Test Mode	E/H Field	Probe Cal. Factor	Test Pos.	Bystander (BS) Positions														
										20 cm	40 cm	60 cm	80 cm	100 cm	120 cm	140 cm	160 cm	180 cm	200 cm					
Roof	HAF4013A, 806-941MHz	5.15	806.0000	42.0	42	CW	E	1.20	BS	0.003	0.004	0.008	0.012	0.020	0.039	0.093	0.215	0.278	0.184	0.5	0.103	0.051	0.051	
Roof	HAF4013A, 806-941MHz	5.15	815.0000	42.0	42	CW	E	1.19	BS	0.002	0.002	0.007	0.013	0.016	0.031	0.101	0.198	0.236	0.157	0.5	0.091	0.045	0.045	
Roof	HAF4013A, 806-941MHz	5.15	824.0000	42.0	42	CW	E	1.18	BS	0.003	0.004	0.008	0.010	0.014	0.052	0.112	0.216	0.231	0.194	0.5	0.100	0.050	0.050	
Roof	HAF4013A, 806-941MHz	5.15	851.0000	42.0	42	CW	E	1.15	BS	0.003	0.005	0.006	0.009	0.016	0.048	0.088	0.203	0.256	0.188	0.5	0.095	0.047	0.047	
Roof	HAF4013A, 806-941MHz	5.15	860.0000	42.0	42	CW	E	1.14	BS	0.003	0.004	0.006	0.011	0.019	0.038	0.091	0.197	0.226	0.130	0.5	0.083	0.041	0.041	
Roof	HAF4013A, 806-941MHz	5.15	869.0000	42.0	42	CW	E	1.14	BS	0.005	0.004	0.003	0.008	0.024	0.038	0.100	0.209	0.211	0.171	0.5	0.088	0.044	0.044	
Roof	HAF4013A, 806-941MHz	5.15	896.0000	36.0	36	CW	E	1.11	BS	0.002	0.004	0.006	0.006	0.011	0.027	0.079	0.152	0.180	0.132	0.5	0.066	0.033	0.033	
Roof	HAF4013A, 806-941MHz	5.15	898.5000	36.0	36	CW	E	1.10	BS	0.001	0.003	0.006	0.007	0.012	0.021	0.060	0.106	0.175	0.147	0.5	0.059	0.030	0.030	
Roof	HAF4013A, 806-941MHz	5.15	900.0000	36.0	36	CW	E	1.10	BS	0.001	0.004	0.005	0.008	0.011	0.022	0.057	0.135	0.180	0.143	0.5	0.062	0.031	0.031	
Roof	HAF4013A, 806-941MHz	5.15	935.0000	36.0	36	CW	E	1.07	BS	0.001	0.001	0.004	0.003	0.009	0.018	0.066	0.093	0.150	0.148	0.5	0.053	0.026	0.026	
Roof	HAF4013A, 806-941MHz	5.15	937.5000	36.0	36	CW	E	1.06	BS	0.001	0.002	0.004	0.005	0.011	0.029	0.077	0.096	0.165	0.135	0.5	0.056	0.028	0.028	
Roof	HAF4013A, 806-941MHz	5.15	939.0000	36.0	36	CW	E	1.06	BS	0.001	0.002	0.003	0.005	0.012	0.028	0.088	0.116	0.153	0.131	0.5	0.057	0.029	0.029	
Roof	HAF4013A, 806-941MHz	5.15	901.5000	4.0	4	CW	E	1.10	BS	0.000	0.000	0.000	0.001	0.001	0.002	0.006	0.013	0.019	0.017	0.5	0.006	0.003	0.003	
Roof	HAF4013A, 806-941MHz	5.15	940.5000	4.0	4	CW	E	1.06	BS	0.000	0.000	0.000	0.000	0.001	0.003	0.009	0.014	0.016	0.012	0.5	0.006	0.003	0.003	

MPE calculations are defined in Section 15.0

**Table D.1 (Continued)**  
**MPE measurement data for Bystander**

D.U.T. Info.										Probe Info.		MPE Measurements										DUT Max. TX Factor	Avg. over Body (mW/cm <sup>2</sup> )	Calc. P.D. (mW/cm <sup>2</sup> )	Max Calc. P.D. (mW/cm <sup>2</sup> )
Ant Loc.	Ant. Model/ Desc.	Ant. Gain (dBi)	Tx Freq (MHz)	Max Pwr (W)	Initial Pwr (W)	Test Mode	E/H Field	Probe Cal. Factor	Test Pos.	Bystander (BS) Positions															
										20 cm	40 cm	60 cm	80 cm	100 cm	120 cm	140 cm	160 cm	180 cm	200 cm						
Roof	HAF4036A, 806-941MHz	2.14	806.0000	42.0	42	CW	E	1.20	BS	0.003	0.004	0.008	0.012	0.017	0.042	0.089	0.202	0.263	0.188	0.5	0.099	0.050	0.050		
Roof	HAF4036A, 806-941MHz	2.14	815.0000	42.0	42	CW	E	1.19	BS	0.003	0.002	0.007	0.017	0.015	0.030	0.104	0.190	0.224	0.143	0.5	0.087	0.044	0.044		
Roof	HAF4036A, 806-941MHz	2.14	824.0000	42.0	42	CW	E	1.18	BS	0.003	0.003	0.008	0.010	0.016	0.050	0.127	0.203	0.224	0.176	0.5	0.097	0.048	0.048		
Roof	HAF4036A, 806-941MHz	2.14	851.0000	42.0	42	CW	E	1.15	BS	0.002	0.004	0.004	0.009	0.014	0.043	0.082	0.173	0.214	0.154	0.5	0.080	0.040	0.040		
Roof	HAF4036A, 806-941MHz	2.14	860.0000	42.0	42	CW	E	1.14	BS	0.003	0.003	0.006	0.009	0.016	0.048	0.093	0.195	0.215	0.143	0.5	0.083	0.042	0.042		
Roof	HAF4036A, 806-941MHz	2.14	869.0000	42.0	42	CW	E	1.14	BS	0.004	0.003	0.003	0.007	0.021	0.033	0.098	0.192	0.172	0.141	0.5	0.077	0.038	0.038		
Roof	HAF4036A, 806-941MHz	2.14	896.0000	36.0	36	CW	E	1.11	BS	0.001	0.003	0.005	0.006	0.009	0.025	0.073	0.125	0.148	0.108	0.5	0.056	0.028	0.028		
Roof	HAF4036A, 806-941MHz	2.14	898.5000	36.0	36	CW	E	1.10	BS	0.001	0.002	0.004	0.006	0.009	0.018	0.049	0.103	0.138	0.118	0.5	0.049	0.025	0.025		
Roof	HAF4036A, 806-941MHz	2.14	900.0000	36.0	36	CW	E	1.10	BS	0.001	0.003	0.004	0.008	0.008	0.018	0.048	0.110	0.145	0.116	0.5	0.051	0.025	0.025		
Roof	HAF4036A, 806-941MHz	2.14	935.0000	36.0	36	CW	E	1.07	BS	0.001	0.001	0.004	0.003	0.008	0.018	0.056	0.093	0.124	0.114	0.5	0.045	0.023	0.023		
Roof	HAF4036A, 806-941MHz	2.14	937.5000	36.0	36	CW	E	1.06	BS	0.001	0.002	0.003	0.004	0.008	0.024	0.062	0.096	0.131	0.100	0.5	0.046	0.023	0.023		
Roof	HAF4036A, 806-941MHz	2.14	939.0000	36.0	36	CW	E	1.06	BS	0.001	0.001	0.002	0.003	0.009	0.023	0.067	0.097	0.121	0.099	0.5	0.045	0.022	0.022		
Roof	HAF4036A, 806-941MHz	2.14	901.5000	4.0	4	CW	E	1.10	BS	0.000	0.000	0.000	0.001	0.001	0.001	0.005	0.010	0.015	0.013	0.5	0.005	0.003	0.003		
Roof	HAF4036A, 806-941MHz	2.14	940.5000	4.0	4	CW	E	1.06	BS	0.000	0.000	0.000	0.000	0.001	0.002	0.008	0.011	0.013	0.009	0.5	0.005	0.002	0.002		

MPE calculations are defined in Section 15.0

**Table D.1 (Continued)**  
**MPE measurement data for Bystander**

D.U.T. Info.							Probe Info.			MPE Measurements											DUT Max. TX Factor	Avg. over Body (mW/cm <sup>2</sup> )	Calc. P.D. (mW/cm <sup>2</sup> )	Max Calc. P.D. (mW/cm <sup>2</sup> )
Ant Loc.	Ant. Model/ Desc.	Ant. Gain (dBi)	Tx Freq (MHz)	Max Pwr (W)	Initial Pwr (W)	Test Mode	E/H Field	Probe Cal. Factor	Test Pos.	Bystander (BS) Positions														
										20 cm	40 cm	60 cm	80 cm	100 cm	120 cm	140 cm	160 cm	180 cm	200 cm					
Roof	HAF4037A, 806-941MHz	3	806.0000	42.0	42	CW	E	1.20	BS	0.008	0.009	0.016	0.032	0.043	0.134	0.259	0.413	0.177	0.029	0.5	0.134	0.067	0.067	
Roof	HAF4037A, 806-941MHz	3	815.0000	42.0	42	CW	E	1.19	BS	0.006	0.006	0.014	0.026	0.038	0.086	0.266	0.343	0.141	0.027	0.5	0.113	0.057	0.057	
Roof	HAF4037A, 806-941MHz	3	824.0000	42.0	42	CW	E	1.18	BS	0.006	0.008	0.017	0.020	0.038	0.129	0.295	0.332	0.176	0.038	0.5	0.125	0.062	0.062	
Roof	HAF4037A, 806-941MHz	3	851.0000	42.0	42	CW	E	1.15	BS	0.004	0.009	0.007	0.020	0.035	0.099	0.180	0.312	0.202	0.066	0.5	0.107	0.054	0.054	
Roof	HAF4037A, 806-941MHz	3	860.0000	42.0	42	CW	E	1.14	BS	0.006	0.006	0.015	0.017	0.031	0.075	0.214	0.341	0.205	0.059	0.5	0.110	0.055	0.055	
Roof	HAF4037A, 806-941MHz	3	869.0000	42.0	42	CW	E	1.14	BS	0.008	0.006	0.009	0.014	0.048	0.072	0.179	0.312	0.189	0.069	0.5	0.103	0.052	0.052	
Roof	HAF4037A, 806-941MHz	3	896.0000	36.0	36	CW	E	1.11	BS	0.003	0.007	0.012	0.020	0.020	0.069	0.160	0.247	0.195	0.065	0.5	0.089	0.044	0.044	
Roof	HAF4037A, 806-941MHz	3	898.5000	36.0	36	CW	E	1.10	BS	0.003	0.006	0.013	0.016	0.020	0.056	0.132	0.203	0.135	0.048	0.5	0.070	0.035	0.035	
Roof	HAF4037A, 806-941MHz	3	900.0000	36.0	36	CW	E	1.10	BS	0.003	0.005	0.011	0.014	0.020	0.051	0.134	0.226	0.192	0.052	0.5	0.078	0.039	0.039	
Roof	HAF4037A, 806-941MHz	3	935.0000	36.0	36	CW	E	1.07	BS	0.004	0.003	0.016	0.006	0.027	0.045	0.162	0.242	0.161	0.042	0.5	0.076	0.038	0.038	
Roof	HAF4037A, 806-941MHz	3	937.5000	36.0	36	CW	E	1.06	BS	0.002	0.004	0.009	0.010	0.024	0.059	0.159	0.238	0.185	0.054	0.5	0.079	0.039	0.039	
Roof	HAF4037A, 806-941MHz	3	939.0000	36.0	36	CW	E	1.06	BS	0.004	0.005	0.008	0.010	0.026	0.053	0.139	0.250	0.164	0.070	0.5	0.077	0.039	0.039	
Roof	HAF4037A, 806-941MHz	3	901.5000	4.0	4	CW	E	1.10	BS	0.000	0.000	0.001	0.001	0.002	0.004	0.013	0.052	0.019	0.006	0.5	0.011	0.005	0.005	
Roof	HAF4037A, 806-941MHz	3	940.5000	4.0	4	CW	E	1.06	BS	0.000	0.000	0.000	0.001	0.003	0.007	0.021	0.032	0.021	0.00	0.5	0.009	0.005	0.005	

MPE calculations are defined in Section 15.0

**Table D.2**  
**MPE measurement data for Passenger**

D.U.T. Info.							Probe Info.			MPE Measurements			DUT Max. TX Factor	Avg. over Body (mW/cm <sup>2</sup> )	Calc. P.D. (mW/cm <sup>2</sup> )	Max Calc. P.D. (mW/cm <sup>2</sup> )
Ant Loc.	Ant. Model/ Desc.	Ant. Gain (dBi)	Tx Freq (MHz)	Max Pwr (W)	Initial Pwr (W)	Test Mode	E/H Field	Probe Cal. Factor	Test Pos.	Passenger/Operator (MC) Positions						
										Head/ Top 1/3	Chest/ Middle 1/3	Lower Trunk/ Bottom 1/3				
Trunk	HAF4013A, 806-941MHz	5.15	806.0000	42.0	42	CW	E	1.20	PB	0.174	0.165	0.143	0.5	0.193	0.096	0.096
Trunk	HAF4013A, 806-941MHz	5.15	815.0000	42.0	42	CW	E	1.19	PB	0.233	0.203	0.105	0.5	0.215	0.107	0.107
Trunk	HAF4013A, 806-941MHz	5.15	824.0000	42.0	42	CW	E	1.18	PB	0.152	0.135	0.089	0.5	0.148	0.074	0.074
Trunk	HAF4013A, 806-941MHz	5.15	851.0000	42.0	42	CW	E	1.15	PB	0.140	0.066	0.079	0.5	0.109	0.055	0.055
Trunk	HAF4013A, 806-941MHz	5.15	860.0000	42.0	42	CW	E	1.14	PB	0.135	0.092	0.086	0.5	0.119	0.059	0.059
Trunk	HAF4013A, 806-941MHz	5.15	869.0000	42.0	42	CW	E	1.14	PB	0.109	0.064	0.057	0.5	0.087	0.044	0.044
Trunk	HAF4013A, 806-941MHz	5.15	896.0000	36.0	36	CW	E	1.11	PB	0.109	0.063	0.033	0.5	0.076	0.038	0.038
Trunk	HAF4013A, 806-941MHz	5.15	898.5000	36.0	36	CW	E	1.10	PB	0.093	0.043	0.031	0.5	0.061	0.031	0.031
Trunk	HAF4013A, 806-941MHz	5.15	900.0000	36.0	36	CW	E	1.10	PB	0.093	0.042	0.03	0.5	0.061	0.030	0.030
Trunk	HAF4013A, 806-941MHz	5.15	935.0000	36.0	36	CW	E	1.07	PB	0.060	0.050	0.052	0.5	0.058	0.029	0.029
Trunk	HAF4013A, 806-941MHz	5.15	937.5000	36.0	36	CW	E	1.06	PB	0.055	0.043	0.041	0.5	0.049	0.025	0.025
Trunk	HAF4013A, 806-941MHz	5.15	939.0000	36.0	36	CW	E	1.06	PB	0.075	0.052	0.06	0.5	0.066	0.033	0.033
Trunk	HAF4013A, 806-941MHz	5.15	901.5000	4.0	4	CW	E	1.10	PB	0.007	0.002	0.003	0.5	0.004	0.002	0.002
Trunk	HAF4013A, 806-941MHz	5.15	940.5000	4.0	4	CW	E	1.06	PB	0.006	0.005	0.004	0.5	0.005	0.003	0.003

MPE calculations are defined in Section 15.0



**Table D.2 (Continued)**  
**MPE measurement data for Passenger**

D.U.T. Info.							Probe Info.			MPE Measurements			DUT Max. TX Factor	Avg. over Body (mW/cm <sup>2</sup> )	Calc. P.D. (mW/cm <sup>2</sup> )	Max Calc. P.D. (mW/cm <sup>2</sup> )
Ant Loc.	Ant. Model/ Desc.	Ant. Gain (dBi)	Tx Freq (MHz)	Max Pwr (W)	Initial Pwr (W)	Test Mode	E/H Field	Probe Cal. Factor	Test Pos.	Passenger/Operator (MC) Positions						
										Head/ Top 1/3	Chest/ Middle 1/3	Lower Trunk/ Bottom 1/3				
Trunk	HAF4036A, 806-941MHz	2.14	806.0000	42.0	42	CW	E	1.20	PB	0.240	0.197	0.146	0.5	0.233	0.117	0.117
Trunk	HAF4036A, 806-941MHz	2.14	815.0000	42.0	42	CW	E	1.19	PB	0.224	0.163	0.100	0.5	0.193	0.097	0.097
Trunk	HAF4036A, 806-941MHz	2.14	824.0000	42.0	42	CW	E	1.18	PB	0.143	0.070	0.075	0.5	0.113	0.057	0.057
Trunk	HAF4036A, 806-941MHz	2.14	851.0000	42.0	42	CW	E	1.15	PB	0.123	0.051	0.082	0.5	0.098	0.049	0.049
Trunk	HAF4036A, 806-941MHz	2.14	860.0000	42.0	42	CW	E	1.14	PB	0.051	0.042	0.027	0.5	0.046	0.023	0.023
Trunk	HAF4036A, 806-941MHz	2.14	869.0000	42.0	42	CW	E	1.14	PB	0.043	0.026	0.017	0.5	0.033	0.016	0.016
Trunk	HAF4036A, 806-941MHz	2.14	896.0000	36.0	36	CW	E	1.11	PB	0.065	0.020	0.018	0.5	0.038	0.019	0.019
Trunk	HAF4036A, 806-941MHz	2.14	898.5000	36.0	36	CW	E	1.10	PB	0.09	0.025	0.018	0.5	0.049	0.024	0.024
Trunk	HAF4036A, 806-941MHz	2.14	900.0000	36.0	36	CW	E	1.10	PB	0.077	0.025	0.025	0.5	0.047	0.023	0.023
Trunk	HAF4036A, 806-941MHz	2.14	935.0000	36.0	36	CW	E	1.07	PB	0.054	0.024	0.040	0.5	0.042	0.021	0.021
Trunk	HAF4036A, 806-941MHz	2.14	937.5000	36.0	36	CW	E	1.06	PB	0.063	0.030	0.034	0.5	0.045	0.022	0.022
Trunk	HAF4036A, 806-941MHz	2.14	939.0000	36.0	36	CW	E	1.06	PB	0.039	0.025	0.038	0.5	0.036	0.018	0.018
Trunk	HAF4036A, 806-941MHz	2.14	901.5000	4.0	4	CW	E	1.10	PB	0.005	0.002	0.002	0.5	0.003	0.002	0.002
Trunk	HAF4036A, 806-941MHz	2.14	940.5000	4.0	4	CW	E	1.06	PB	0.003	0.003	0.002	0.5	0.003	0.001	0.001

MPE calculations are defined in Section 15.0

**Table D.2 (Continued)**  
**MPE measurement data for Passenger**

D.U.T. Info.							Probe Info.			MPE Measurements			DUT Max. TX Factor	Avg. over Body (mW/cm <sup>2</sup> )	Calc. P.D. (mW/cm <sup>2</sup> )	Max Calc. P.D. (mW/cm <sup>2</sup> )
Ant Loc.	Ant. Model/ Desc.	Ant. Gain (dBi)	Tx Freq (MHz)	Max Pwr (W)	Initial Pwr (W)	Test Mode	E/H Field	Probe Cal. Factor	Test Pos.	Passenger/Operator (MC) Positions						
										Head/ Top 1/3	Chest/ Middle 1/3	Lower Trunk/ Bottom 1/3				
Trunk	HAF4037A, 806-941MHz	3	806.0000	42.0	42	CW	E	1.20	PB	0.381	0.265	0.292	0.5	0.375	0.188	0.188
Trunk	HAF4037A, 806-941MHz	3	815.0000	42.0	42	CW	E	1.19	PB	0.495	0.320	0.250	0.5	0.422	0.211	0.211
Trunk	HAF4037A, 806-941MHz	3	824.0000	42.0	42	CW	E	1.18	PB	0.361	0.323	0.216	0.5	0.354	0.177	0.177
Trunk	HAF4037A, 806-941MHz	3	851.0000	42.0	42	CW	E	1.15	PB	0.345	0.113	0.067	0.5	0.201	0.101	0.101
Trunk	HAF4037A, 806-941MHz	3	860.0000	42.0	42	CW	E	1.14	PB	0.217	0.187	0.231	0.5	0.241	0.121	0.121
Trunk	HAF4037A, 806-941MHz	3	869.0000	42.0	42	CW	E	1.14	PB	0.154	0.167	0.088	0.5	0.155	0.078	0.078
Trunk	HAF4037A, 806-941MHz	3	896.0000	36.0	36	CW	E	1.11	PB	0.097	0.078	0.070	0.5	0.091	0.045	0.045
Trunk	HAF4037A, 806-941MHz	3	898.5000	36.0	36	CW	E	1.10	PB	0.212	0.094	0.062	0.5	0.135	0.067	0.067
Trunk	HAF4037A, 806-941MHz	3	900.0000	36.0	36	CW	E	1.10	PB	0.187	0.081	0.055	0.5	0.118	0.059	0.059
Trunk	HAF4037A, 806-941MHz	3	935.0000	36.0	36	CW	E	1.07	PB	0.172	0.131	0.122	0.5	0.152	0.076	0.076
Trunk	HAF4037A, 806-941MHz	3	937.5000	36.0	36	CW	E	1.06	PB	0.219	0.173	0.133	0.5	0.186	0.093	0.093
Trunk	HAF4037A, 806-941MHz	3	939.0000	36.0	36	CW	E	1.06	PB	0.163	0.18	0.129	0.5	0.167	0.083	0.083
Trunk	HAF4037A, 806-941MHz	3	901.5000	4.0	4	CW	E	1.10	PB	0.018	0.007	0.010	0.5	0.013	0.006	0.006
Trunk	HAF4037A, 806-941MHz	3	940.5000	4.0	4	CW	E	1.06	PB	0.02	0.019	0.013	0.5	0.018	0.009	0.009

MPE calculations are defined in Section 15.

**Table D.2 (Continued)**  
**MPE measurement data for Passenger**

D.U.T. Info.										Probe Info.			MPE Measurements			
Ant Loc.	Ant. Model/ Desc.	Ant. Gain (dBi)	Tx Freq (MHz)	Max Pwr (W)	Initial Pwr (W)	Test Mode	E/H Field	Probe Cal. Factor	Test Pos.	Passenger/Operator (MC) Positions			DUT Max. TX Factor	Avg. over Body (mW/cm <sup>2</sup> )	Calc. P.D. (mW/cm <sup>2</sup> )	Max Calc. P.D. (mW/cm <sup>2</sup> )
										Head/ Top 1/3	Chest/ Middle 1/3	Lower Trunk/ Bottom 1/3				
Trunk	HAF4013A, 806-941MHz	5.15	806.0000	42.0	42	CW	E	1.20	PF	0.152	0.076	0.038	0.5	0.106	0.053	0.053
Trunk	HAF4013A, 806-941MHz	5.15	815.0000	42.0	42	CW	E	1.19	PF	0.149	0.045	0.087	0.5	0.111	0.056	0.056
Trunk	HAF4013A, 806-941MHz	5.15	824.0000	42.0	42	CW	E	1.18	PF	0.16	0.037	0.085	0.5	0.111	0.055	0.055
Trunk	HAF4013A, 806-941MHz	5.15	851.0000	42.0	42	CW	E	1.15	PF	0.133	0.025	0.043	0.5	0.077	0.039	0.039
Trunk	HAF4013A, 806-941MHz	5.15	860.0000	42.0	42	CW	E	1.14	PF	0.143	0.034	0.047	0.5	0.085	0.043	0.043
Trunk	HAF4013A, 806-941MHz	5.15	869.0000	42.0	42	CW	E	1.14	PF	0.071	0.018	0.03	0.5	0.045	0.023	0.023
Trunk	HAF4013A, 806-941MHz	5.15	896.0000	36.0	36	CW	E	1.11	PF	0.118	0.041	0.020	0.5	0.066	0.033	0.033
Trunk	HAF4013A, 806-941MHz	5.15	898.5000	36.0	36	CW	E	1.10	PF	0.138	0.037	0.017	0.5	0.070	0.035	0.035
Trunk	HAF4013A, 806-941MHz	5.15	900.0000	36.0	36	CW	E	1.10	PF	0.115	0.032	0.018	0.5	0.061	0.030	0.030
Trunk	HAF4013A, 806-941MHz	5.15	935.0000	36.0	36	CW	E	1.07	PF	0.078	0.038	0.030	0.5	0.052	0.026	0.026
Trunk	HAF4013A, 806-941MHz	5.15	937.5000	36.0	36	CW	E	1.06	PF	0.053	0.027	0.025	0.5	0.037	0.019	0.019
Trunk	HAF4013A, 806-941MHz	5.15	939.0000	36.0	36	CW	E	1.06	PF	0.062	0.033	0.024	0.5	0.042	0.021	0.021
Trunk	HAF4013A, 806-941MHz	5.15	901.5000	4.0	4	CW	E	1.10	PF	0.008	0.003	0.001	0.5	0.004	0.002	0.002
Trunk	HAF4013A, 806-941MHz	5.15	940.5000	4.0	4	CW	E	1.06	PF	0.005	0.001	0.001	0.5	0.002	0.001	0.001

MPE calculations are defined in Section 15.0

**Table D.2 (Continued)**  
**MPE measurement data for Passenger**

D.U.T. Info.							Probe Info.		Test Pos.	MPE Measurements			DUT Max. TX Factor	Avg. over Body (mW/cm <sup>2</sup> )	Calc. P.D. (mW/cm <sup>2</sup> )	Max Calc. P.D. (mW/cm <sup>2</sup> )
Ant Loc.	Ant. Model/ Desc.	Ant. Gain (dBi)	Tx Freq (MHz)	Max Pwr (W)	Initial Pwr (W)	Test Mode	E/H Field	Probe Cal. Factor		Passenger/Operator (MC) Positions						
										Head/ Top 1/3	Chest/ Middle 1/3	Lower Trunk/ Bottom 1/3				
Trunk	HAF4036A, 806-941MHz	2.14	806.0000	42.0	42	CW	E	1.20	PF	0.146	0.068	0.047	0.5	0.104	0.052	0.052
Trunk	HAF4036A, 806-941MHz	2.14	815.0000	42.0	42	CW	E	1.19	PF	0.129	0.046	0.082	0.5	0.102	0.051	0.051
Trunk	HAF4036A, 806-941MHz	2.14	824.0000	42.0	42	CW	E	1.18	PF	0.162	0.048	0.098	0.5	0.121	0.061	0.061
Trunk	HAF4036A, 806-941MHz	2.14	851.0000	42.0	42	CW	E	1.15	PF	0.134	0.023	0.043	0.5	0.077	0.038	0.038
Trunk	HAF4036A, 806-941MHz	2.14	860.0000	42.0	42	CW	E	1.14	PF	0.104	0.027	0.047	0.5	0.068	0.034	0.034
Trunk	HAF4036A, 806-941MHz	2.14	869.0000	42.0	42	CW	E	1.14	PF	0.123	0.017	0.037	0.5	0.067	0.034	0.034
Trunk	HAF4036A, 806-941MHz	2.14	896.0000	36.0	36	CW	E	1.11	PF	0.128	0.040	0.018	0.5	0.069	0.034	0.034
Trunk	HAF4036A, 806-941MHz	2.14	898.5000	36.0	36	CW	E	1.10	PF	0.144	0.03	0.024	0.5	0.073	0.036	0.036
Trunk	HAF4036A, 806-941MHz	2.14	900.0000	36.0	36	CW	E	1.10	PF	0.103	0.023	0.016	0.5	0.052	0.026	0.026
Trunk	HAF4036A, 806-941MHz	2.14	935.0000	36.0	36	CW	E	1.07	PF	0.047	0.033	0.013	0.5	0.033	0.017	0.017
Trunk	HAF4036A, 806-941MHz	2.14	937.5000	36.0	36	CW	E	1.06	PF	0.050	0.036	0.011	0.5	0.034	0.017	0.017
Trunk	HAF4036A, 806-941MHz	2.14	939.0000	36.0	36	CW	E	1.06	PF	0.036	0.026	0.008	0.5	0.025	0.012	0.012
Trunk	HAF4036A, 806-941MHz	2.14	901.5000	4.0	4	CW	E	1.10	PF	0.008	0.002	0.001	0.5	0.004	0.002	0.002
Trunk	HAF4036A, 806-941MHz	2.14	940.5000	4.0	4	CW	E	1.06	PF	0.002	0.002	0.001	0.5	0.002	0.001	0.001

MPE calculations are defined in Section 15.

**Table D.2 (Continued)**  
**MPE measurement data for Passenger**

D.U.T. Info.							Probe Info.			MPE Measurements			DUT Max. TX Factor	Avg. over Body (mW/cm <sup>2</sup> )	Calc. P.D. (mW/cm <sup>2</sup> )	Max Calc. P.D. (mW/cm <sup>2</sup> )
Ant Loc.	Ant. Model/ Desc.	Ant. Gain (dBi)	Tx Freq (MHz)	Max Pwr (W)	Initial Pwr (W)	Test Mode	E/H Field	Probe Cal. Factor	Test Pos.	Passenger/Operator (MC) Positions						
										Head/ Top 1/3	Chest/ Middle 1/3	Lower Trunk/ Bottom 1/3				
Trunk	HAF4037A, 806-941MHz	3	806.0000	42.0	42	CW	E	1.20	PF	0.295	0.138	0.104	0.5	0.215	0.107	0.107
Trunk	HAF4037A, 806-941MHz	3	815.0000	42.0	42	CW	E	1.19	PF	0.275	0.136	0.172	0.5	0.231	0.116	0.116
Trunk	HAF4037A, 806-941MHz	3	824.0000	42.0	42	CW	E	1.18	PF	0.325	0.140	0.212	0.5	0.266	0.133	0.133
Trunk	HAF4037A, 806-941MHz	3	851.0000	42.0	42	CW	E	1.15	PF	0.171	0.058	0.079	0.5	0.118	0.059	0.059
Trunk	HAF4037A, 806-941MHz	3	860.0000	42.0	42	CW	E	1.14	PF	0.148	0.066	0.034	0.5	0.094	0.047	0.047
Trunk	HAF4037A, 806-941MHz	3	869.0000	42.0	42	CW	E	1.14	PF	0.136	0.040	0.048	0.5	0.085	0.043	0.043
Trunk	HAF4037A, 806-941MHz	3	896.0000	36.0	36	CW	E	1.11	PF	0.188	0.053	0.023	0.5	0.098	0.049	0.049
Trunk	HAF4037A, 806-941MHz	3	898.5000	36.0	36	CW	E	1.10	PF	0.218	0.034	0.028	0.5	0.103	0.051	0.051
Trunk	HAF4037A, 806-941MHz	3	900.0000	36.0	36	CW	E	1.10	PF	0.209	0.037	0.024	0.5	0.099	0.050	0.050
Trunk	HAF4037A, 806-941MHz	3	935.0000	36.0	36	CW	E	1.07	PF	0.110	0.096	0.060	0.5	0.095	0.047	0.047
Trunk	HAF4037A, 806-941MHz	3	937.5000	36.0	36	CW	E	1.06	PF	0.104	0.056	0.058	0.5	0.077	0.039	0.039
Trunk	HAF4037A, 806-941MHz	3	939.0000	36.0	36	CW	E	1.06	PF	0.086	0.097	0.041	0.5	0.079	0.040	0.040
Trunk	HAF4037A, 806-941MHz	3	901.5000	4.0	4	CW	E	1.10	PF	0.019	0.003	0.003	0.5	0.009	0.005	0.005
Trunk	HAF4037A, 806-941MHz	3	940.5000	4.0	4	CW	E	1.06	PF	0.007	0.006	0.004	0.5	0.006	0.003	0.003

MPE calculations are defined in Section 15.0

**Table D.2 (Continued)**  
**MPE measurement data for Passenger**

D.U.T. Info.							Probe Info.			MPE Measurements			DUT Max. TX Factor	Avg. over Body (mW/cm <sup>2</sup> )	Calc. P.D. (mW/cm <sup>2</sup> )	Max Calc. P.D. (mW/cm <sup>2</sup> )
Ant Loc.	Ant. Model/ Desc.	Ant. Gain (dBi)	Tx Freq (MHz)	Max Pwr (W)	Initial Pwr (W)	Test Mode	E/H Field	Probe Cal. Factor	Test Pos.	Passenger/Operator (MC) Positions						
										Head/ Top 1/3	Chest/ Middle 1/3	Lower Trunk/ Bottom 1/3				
Roof	HAF4013A, 806-941MHz	5.15	806.0000	42.0	42	CW	E	1.20	PB	0.026	0.022	0.027	0.5	0.030	0.015	0.015
Roof	HAF4013A, 806-941MHz	5.15	815.0000	42.0	42	CW	E	1.19	PB	0.015	0.014	0.024	0.5	0.021	0.011	0.011
Roof	HAF4013A, 806-941MHz	5.15	824.0000	42.0	42	CW	E	1.18	PB	0.009	0.006	0.008	0.5	0.009	0.005	0.005
Roof	HAF4013A, 806-941MHz	5.15	851.0000	42.0	42	CW	E	1.15	PB	0.012	0.008	0.013	0.5	0.013	0.006	0.006
Roof	HAF4013A, 806-941MHz	5.15	860.0000	42.0	42	CW	E	1.14	PB	0.026	0.007	0.015	0.5	0.018	0.009	0.009
Roof	HAF4013A, 806-941MHz	5.15	869.0000	42.0	42	CW	E	1.14	PB	0.021	0.005	0.011	0.5	0.014	0.007	0.007
Roof	HAF4013A, 806-941MHz	5.15	896.0000	36.0	36	CW	E	1.11	PB	0.020	0.011	0.011	0.5	0.016	0.008	0.008
Roof	HAF4013A, 806-941MHz	5.15	898.5000	36.0	36	CW	E	1.10	PB	0.016	0.012	0.007	0.5	0.013	0.006	0.006
Roof	HAF4013A, 806-941MHz	5.15	900.0000	36.0	36	CW	E	1.10	PB	0.017	0.008	0.012	0.5	0.014	0.007	0.007
Roof	HAF4013A, 806-941MHz	5.15	935.0000	36.0	36	CW	E	1.07	PB	0.005	0.006	0.013	0.5	0.009	0.004	0.004
Roof	HAF4013A, 806-941MHz	5.15	937.5000	36.0	36	CW	E	1.06	PB	0.004	0.004	0.012	0.5	0.007	0.004	0.004
Roof	HAF4013A, 806-941MHz	5.15	939.0000	36.0	36	CW	E	1.06	PB	0.004	0.005	0.010	0.5	0.007	0.003	0.003
Roof	HAF4013A, 806-941MHz	5.15	901.5000	4.0	4	CW	E	1.10	PB	0.002	0.001	0.001	0.5	0.001	0.001	0.001
Roof	HAF4013A, 806-941MHz	5.15	940.5000	4.0	4	CW	E	1.06	PB	0.001	0.001	0.001	0.5	0.001	0.001	0.001

MPE calculations are defined in Section 15.0

**Table D.2 (Continued)**  
**MPE measurement data for Passenger**

D.U.T. Info.							Probe Info.			MPE Measurements			DUT Max. TX Factor	Avg. over Body (mW/cm <sup>2</sup> )	Calc. P.D. (mW/cm <sup>2</sup> )	Max Calc. P.D. (mW/cm <sup>2</sup> )
Ant Loc.	Ant. Model/ Desc.	Ant. Gain (dBi)	Tx Freq (MHz)	Max Pwr (W)	Initial Pwr (W)	Test Mode	E/H Field	Probe Cal. Factor	Test Pos.	Passenger/Operator (MC) Positions						
										Head/ Top 1/3	Chest/ Middle 1/3	Lower Trunk/ Bottom 1/3				
Roof	HAF4036A, 806-941MHz	2.14	806.0000	42.0	42	CW	E	1.20	PB	0.027	0.022	0.026	0.5	0.030	0.015	0.015
Roof	HAF4036A, 806-941MHz	2.14	815.0000	42.0	42	CW	E	1.19	PB	0.023	0.014	0.040	0.5	0.031	0.015	0.015
Roof	HAF4036A, 806-941MHz	2.14	824.0000	42.0	42	CW	E	1.18	PB	0.012	0.007	0.03	0.5	0.019	0.010	0.010
Roof	HAF4036A, 806-941MHz	2.14	851.0000	42.0	42	CW	E	1.15	PB	0.015	0.009	0.014	0.5	0.015	0.007	0.007
Roof	HAF4036A, 806-941MHz	2.14	860.0000	42.0	42	CW	E	1.14	PB	0.023	0.014	0.015	0.5	0.020	0.010	0.010
Roof	HAF4036A, 806-941MHz	2.14	869.0000	42.0	42	CW	E	1.14	PB	0.018	0.014	0.014	0.5	0.017	0.009	0.009
Roof	HAF4036A, 806-941MHz	2.14	896.0000	36.0	36	CW	E	1.11	PB	0.018	0.011	0.014	0.5	0.016	0.008	0.008
Roof	HAF4036A, 806-941MHz	2.14	898.5000	36.0	36	CW	E	1.10	PB	0.018	0.011	0.011	0.5	0.015	0.007	0.007
Roof	HAF4036A, 806-941MHz	2.14	900.0000	36.0	36	CW	E	1.10	PB	0.018	0.012	0.014	0.5	0.016	0.008	0.008
Roof	HAF4036A, 806-941MHz	2.14	935.0000	36.0	36	CW	E	1.07	PB	0.006	0.006	0.021	0.5	0.012	0.006	0.006
Roof	HAF4036A, 806-941MHz	2.14	937.5000	36.0	36	CW	E	1.06	PB	0.004	0.003	0.013	0.5	0.007	0.004	0.004
Roof	HAF4036A, 806-941MHz	2.14	939.0000	36.0	36	CW	E	1.06	PB	0.003	0.003	0.01	0.5	0.006	0.003	0.003
Roof	HAF4036A, 806-941MHz	2.14	901.5000	4.0	4	CW	E	1.10	PB	0.001	0.001	0.001	0.5	0.001	0.001	0.001
Roof	HAF4036A, 806-941MHz	2.14	940.5000	4.0	4	CW	E	1.06	PB	0.001	0.001	0.001	0.5	0.001	0.001	0.001

MPE calculations are defined in Section 15.0

**Table D.2 (Continued)**  
**MPE measurement data for Passenger**

D.U.T. Info.							Probe Info.			MPE Measurements			DUT Max. TX Factor	Avg. over Body (mW/cm <sup>2</sup> )	Calc. P.D. (mW/cm <sup>2</sup> )	Max Calc. P.D. (mW/cm <sup>2</sup> )
Ant Loc.	Ant. Model/ Desc.	Ant. Gain (dBi)	Tx Freq (MHz)	Max Pwr (W)	Initial Pwr (W)	Test Mode	E/H Field	Probe Cal. Factor	Test Pos.	Passenger/Operator (MC) Positions						
										Head/ Top 1/3	Chest/ Middle 1/3	Lower Trunk/ Bottom 1/3				
Roof	HAF4037A, 806-941MHz	3	806.0000	42.0	42	CW	E	1.20	PB	0.065	0.049	0.059	0.5	0.069	0.035	0.035
Roof	HAF4037A, 806-941MHz	3	815.0000	42.0	42	CW	E	1.19	PB	0.051	0.041	0.035	0.5	0.050	0.025	0.025
Roof	HAF4037A, 806-941MHz	3	824.0000	42.0	42	CW	E	1.18	PB	0.026	0.03	0.031	0.5	0.034	0.017	0.017
Roof	HAF4037A, 806-941MHz	3	851.0000	42.0	42	CW	E	1.15	PB	0.041	0.022	0.031	0.5	0.036	0.018	0.018
Roof	HAF4037A, 806-941MHz	3	860.0000	42.0	42	CW	E	1.14	PB	0.049	0.020	0.039	0.5	0.041	0.021	0.021
Roof	HAF4037A, 806-941MHz	3	869.0000	42.0	42	CW	E	1.14	PB	0.068	0.038	0.036	0.5	0.054	0.027	0.027
Roof	HAF4037A, 806-941MHz	3	896.0000	36.0	36	CW	E	1.11	PB	0.047	0.024	0.020	0.5	0.034	0.017	0.017
Roof	HAF4037A, 806-941MHz	3	898.5000	36.0	36	CW	E	1.10	PB	0.041	0.024	0.029	0.5	0.034	0.017	0.017
Roof	HAF4037A, 806-941MHz	3	900.0000	36.0	36	CW	E	1.10	PB	0.042	0.027	0.030	0.5	0.036	0.018	0.018
Roof	HAF4037A, 806-941MHz	3	935.0000	36.0	36	CW	E	1.07	PB	0.017	0.023	0.058	0.5	0.035	0.017	0.017
Roof	HAF4037A, 806-941MHz	3	937.5000	36.0	36	CW	E	1.06	PB	0.015	0.024	0.025	0.5	0.023	0.011	0.011
Roof	HAF4037A, 806-941MHz	3	939.0000	36.0	36	CW	E	1.06	PB	0.012	0.009	0.028	0.5	0.017	0.009	0.009
Roof	HAF4037A, 806-941MHz	3	901.5000	4.0	4	CW	E	1.10	PB	0.004	0.001	0.002	0.5	0.003	0.001	0.001
Roof	HAF4037A, 806-941MHz	3	940.5000	4.0	4	CW	E	1.06	PB	0.001	0.002	0.003	0.5	0.002	0.001	0.001

MPE calculations are defined in Section 15.0



**Table D.2 (Continued)**  
**MPE measurement data for Passenger**

D.U.T. Info.							Probe Info.		Test Pos.	MPE Measurements			DUT Max. TX Factor	Avg. over Body (mW/cm <sup>2</sup> )	Calc. P.D. (mW/cm <sup>2</sup> )	Max Calc. P.D. (mW/cm <sup>2</sup> )
Ant Loc.	Ant. Model/ Desc.	Ant. Gain (dBi)	Tx Freq (MHz)	Max Pwr (W)	Initial Pwr (W)	Test Mode	E/H Field	Probe Cal. Factor		Passenger/Operator (MC) Positions						
										Head/ Top 1/3	Chest/ Middle 1/3	Lower Trunk/ Bottom 1/3				
Roof	HAF4013A, 806-941MHz	5.15	806.0000	42.0	42	CW	E	1.20	PF	0.021	0.013	0.020	0.5	0.022	0.011	0.011
Roof	HAF4013A, 806-941MHz	5.15	815.0000	42.0	42	CW	E	1.19	PF	0.006	0.010	0.016	0.5	0.013	0.006	0.006
Roof	HAF4013A, 806-941MHz	5.15	824.0000	42.0	42	CW	E	1.18	PF	0.013	0.005	0.013	0.5	0.012	0.006	0.006
Roof	HAF4013A, 806-941MHz	5.15	851.0000	42.0	42	CW	E	1.15	PF	0.009	0.008	0.006	0.5	0.009	0.004	0.004
Roof	HAF4013A, 806-941MHz	5.15	860.0000	42.0	42	CW	E	1.14	PF	0.004	0.008	0.008	0.5	0.008	0.004	0.004
Roof	HAF4013A, 806-941MHz	5.15	869.0000	42.0	42	CW	E	1.14	PF	0.004	0.004	0.013	0.5	0.008	0.004	0.004
Roof	HAF4013A, 806-941MHz	5.15	896.0000	36.0	36	CW	E	1.11	PF	0.010	0.008	0.021	0.5	0.014	0.007	0.007
Roof	HAF4013A, 806-941MHz	5.15	898.5000	36.0	36	CW	E	1.10	PF	0.003	0.005	0.015	0.5	0.008	0.004	0.004
Roof	HAF4013A, 806-941MHz	5.15	900.0000	36.0	36	CW	E	1.10	PF	0.006	0.006	0.018	0.5	0.011	0.006	0.006
Roof	HAF4013A, 806-941MHz	5.15	935.0000	36.0	36	CW	E	1.07	PF	0.007	0.011	0.004	0.5	0.008	0.004	0.004
Roof	HAF4013A, 806-941MHz	5.15	937.5000	36.0	36	CW	E	1.06	PF	0.004	0.005	0.005	0.5	0.005	0.002	0.002
Roof	HAF4013A, 806-941MHz	5.15	939.0000	36.0	36	CW	E	1.06	PF	0.004	0.005	0.006	0.5	0.005	0.003	0.003
Roof	HAF4013A, 806-941MHz	5.15	901.5000	4.0	4	CW	E	1.10	PF	0.000	0.001	0.001	0.5	0.001	0.000	0.000
Roof	HAF4013A, 806-941MHz	5.15	940.5000	4.0	4	CW	E	1.06	PF	0.001	0	0	0.5	0.000	0.000	0.000

MPE calculations are defined in Section 15.0

**Table D.2 (Continued)**  
**MPE measurement data for Passenger**

D.U.T. Info.							Probe Info.			MPE Measurements			DUT Max. TX Factor	Avg. over Body (mW/cm <sup>2</sup> )	Calc. P.D. (mW/cm <sup>2</sup> )	Max Calc. P.D. (mW/cm <sup>2</sup> )
Ant Loc.	Ant. Model/ Desc.	Ant. Gain (dBi)	Tx Freq (MHz)	Max Pwr (W)	Initial Pwr (W)	Test Mode	E/H Field	Probe Cal. Factor	Test Pos.	Passenger/Operator (MC) Positions						
										Head/ Top 1/3	Chest/ Middle 1/3	Lower Trunk/ Bottom 1/3				
Roof	HAF4036A, 806-941MHz	2.14	806.0000	42.0	42	CW	E	1.20	PF	0.025	0.014	0.029	0.5	0.027	0.014	0.014
Roof	HAF4036A, 806-941MHz	2.14	815.0000	42.0	42	CW	E	1.19	PF	0.008	0.014	0.017	0.5	0.015	0.008	0.008
Roof	HAF4036A, 806-941MHz	2.14	824.0000	42.0	42	CW	E	1.18	PF	0.011	0.006	0.013	0.5	0.012	0.006	0.006
Roof	HAF4036A, 806-941MHz	2.14	851.0000	42.0	42	CW	E	1.15	PF	0.004	0.006	0.006	0.5	0.006	0.003	0.003
Roof	HAF4036A, 806-941MHz	2.14	860.0000	42.0	42	CW	E	1.14	PF	0.014	0.005	0.006	0.5	0.010	0.005	0.005
Roof	HAF4036A, 806-941MHz	2.14	869.0000	42.0	42	CW	E	1.14	PF	0.004	0.004	0.008	0.5	0.006	0.003	0.003
Roof	HAF4036A, 806-941MHz	2.14	896.0000	36.0	36	CW	E	1.11	PF	0.004	0.010	0.022	0.5	0.013	0.007	0.007
Roof	HAF4036A, 806-941MHz	2.14	898.5000	36.0	36	CW	E	1.10	PF	0.004	0.009	0.005	0.5	0.007	0.003	0.003
Roof	HAF4036A, 806-941MHz	2.14	900.0000	36.0	36	CW	E	1.10	PF	0.002	0.007	0.014	0.5	0.008	0.004	0.004
Roof	HAF4036A, 806-941MHz	2.14	935.0000	36.0	36	CW	E	1.07	PF	0.004	0.005	0.004	0.5	0.005	0.002	0.002
Roof	HAF4036A, 806-941MHz	2.14	937.5000	36.0	36	CW	E	1.06	PF	0.007	0.011	0.003	0.5	0.007	0.004	0.004
Roof	HAF4036A, 806-941MHz	2.14	939.0000	36.0	36	CW	E	1.06	PF	0.003	0.004	0.003	0.5	0.004	0.002	0.002
Roof	HAF4036A, 806-941MHz	2.14	901.5000	4.0	4	CW	E	1.10	PF	0.000	0.000	0.001	0.5	0.000	0.000	0.000
Roof	HAF4036A, 806-941MHz	2.14	940.5000	4.0	4	CW	E	1.06	PF	0	0	0.001	0.5	0.000	0.000	0.000

MPE calculations are defined in Section 15.0

**Table D.2 (Continued)**  
**MPE measurement data for Passenger**

D.U.T. Info.										Probe Info.			MPE Measurements			
Ant Loc.	Ant. Model/ Desc.	Ant. Gain (dBi)	Tx Freq (MHz)	Max Pwr (W)	Initial Pwr (W)	Test Mode	E/H Field	Probe Cal. Factor	Test Pos.	Passenger/Operator (MC) Positions			DUT Max. TX Factor	Avg. over Body (mW/cm <sup>2</sup> )	Calc. P.D. (mW/cm <sup>2</sup> )	Max Calc. P.D. (mW/cm <sup>2</sup> )
										Head/ Top 1/3	Chest/ Middle 1/3	Lower Trunk/ Bottom 1/3				
Roof	HAF4037A, 806-941MHz	3	806.0000	42.0	42	CW	E	1.20	PF	0.038	0.027	0.059	0.5	0.050	0.025	0.025
Roof	HAF4037A, 806-941MHz	3	815.0000	42.0	42	CW	E	1.19	PF	0.039	0.035	0.034	0.5	0.043	0.021	0.021
Roof	HAF4037A, 806-941MHz	3	824.0000	42.0	42	CW	E	1.18	PF	0.027	0.02	0.02	0.5	0.026	0.013	0.013
Roof	HAF4037A, 806-941MHz	3	851.0000	42.0	42	CW	E	1.15	PF	0.022	0.014	0.022	0.5	0.022	0.011	0.011
Roof	HAF4037A, 806-941MHz	3	860.0000	42.0	42	CW	E	1.14	PF	0.052	0.022	0.017	0.5	0.035	0.017	0.017
Roof	HAF4037A, 806-941MHz	3	869.0000	42.0	42	CW	E	1.14	PF	0.015	0.019	0.033	0.5	0.025	0.013	0.013
Roof	HAF4037A, 806-941MHz	3	896.0000	36.0	36	CW	E	1.11	PF	0.026	0.016	0.040	0.5	0.030	0.015	0.015
Roof	HAF4037A, 806-941MHz	3	898.5000	36.0	36	CW	E	1.10	PF	0.019	0.016	0.034	0.5	0.025	0.013	0.013
Roof	HAF4037A, 806-941MHz	3	900.0000	36.0	36	CW	E	1.10	PF	0.011	0.024	0.028	0.5	0.023	0.012	0.012
Roof	HAF4037A, 806-941MHz	3	935.0000	36.0	36	CW	E	1.07	PF	0.021	0.026	0.015	0.5	0.022	0.011	0.011
Roof	HAF4037A, 806-941MHz	3	937.5000	36.0	36	CW	E	1.06	PF	0.016	0.02	0.01	0.5	0.016	0.008	0.008
Roof	HAF4037A, 806-941MHz	3	939.0000	36.0	36	CW	E	1.06	PF	0.026	0.02	0.013	0.5	0.021	0.010	0.010
Roof	HAF4037A, 806-941MHz	3	901.5000	4.0	4	CW	E	1.10	PF	0.001	0.002	0.002	0.5	0.002	0.001	0.001
Roof	HAF4037A, 806-941MHz	3	940.5000	4.0	4	CW	E	1.06	PF	0.002	0.001	0.001	0.5	0.001	0.001	0.001

MPE calculations are defined in Section 15.0

**Table D.3**  
**LMR 8/900MHz MPE Results for FCC**

Pmax (W) 42/36/4		P initial (W)																
FCC Limit (mW/cm <sup>2</sup> )		42	42	42	42	42	42	36	36	36	36	36	36	4	4			
Test Pos	Angle (deg)	Trunk/ Roof	E/H Field	Antenna no.	f1	f2	f3	f4	f5	f6	f7	f8	f9	f10	f11	f12	f13	f14
					806.0000	815.0000	824.0000	851.0000	860.0000	869.0000	896.0000	896.5000	900.0000	935.0000	937.5000	939.0000	901.5000	940.5000
B5	0	Roof	E	1	0.051	0.045	0.050	0.047	0.041	0.044	0.033	0.030	0.031	0.026	0.028	0.029	0.003	0.003
B5	0	Roof	E	2	0.050	0.044	0.048	0.040	0.042	0.038	0.028	0.025	0.025	0.023	0.023	0.022	0.003	0.002
B5	0	Roof	E	3	0.067	0.057	0.062	0.054	0.055	0.052	0.044	0.035	0.039	0.038	0.039	0.039	0.005	0.005
B5	0	Trunk	E	1	0.102	0.096	0.092	0.093	0.093	0.088	0.066	0.060	0.059	0.062	0.056	0.056	0.006	0.006
B5	0	Trunk	E	2	0.100	0.090	0.080	0.077	0.076	0.073	0.051	0.046	0.047	0.049	0.044	0.043	0.005	0.005
B5	0	Trunk	E	3	0.107	0.089	0.088	0.091	0.085	0.093	0.058	0.054	0.054	0.081	0.077	0.074	0.006	0.009
B5	45	Trunk	E	3	0.089													
B5	90	Trunk	E	3	0.106													
PB	0	Roof	E	1	0.015	0.011	0.005	0.006	0.009	0.007	0.008	0.006	0.007	0.004	0.004	0.003	0.001	0.001
PB	0	Roof	E	2	0.015	0.015	0.010	0.007	0.010	0.009	0.008	0.007	0.008	0.006	0.004	0.003	0.001	0.001
PB	0	Roof	E	3	0.035	0.025	0.017	0.018	0.021	0.027	0.017	0.017	0.018	0.017	0.011	0.009	0.001	0.001
PB	0	Trunk	E	1	0.096	0.107	0.074	0.055	0.059	0.044	0.038	0.031	0.030	0.029	0.025	0.033	0.002	0.003
PB	0	Trunk	E	2	0.117	0.097	0.057	0.049	0.023	0.016	0.019	0.024	0.023	0.021	0.022	0.018	0.002	0.001
PB	0	Trunk	E	3	0.188	0.211	0.177	0.101	0.121	0.078	0.045	0.067	0.059	0.076	0.093	0.083	0.006	0.009
PF	0	Roof	E	1	0.011	0.006	0.006	0.004	0.004	0.004	0.007	0.004	0.006	0.004	0.002	0.003	0.000	0.000
PF	0	Roof	E	2	0.014	0.008	0.006	0.003	0.005	0.003	0.007	0.003	0.004	0.002	0.004	0.002	0.000	0.000
PF	0	Roof	E	3	0.025	0.021	0.013	0.011	0.017	0.013	0.015	0.013	0.012	0.011	0.008	0.010	0.001	0.001
PF	0	Trunk	E	1	0.053	0.056	0.055	0.039	0.043	0.023	0.033	0.035	0.030	0.026	0.019	0.021	0.002	0.001
PF	0	Trunk	E	2	0.052	0.051	0.061	0.038	0.034	0.034	0.034	0.036	0.026	0.017	0.017	0.012	0.002	0.001
PF	0	Trunk	E	3	0.107	0.116	0.133	0.059	0.047	0.043	0.049	0.051	0.050	0.047	0.039	0.040	0.005	0.003