



DECLARATION OF COMPLIANCE: MPE ASSESSMENT Part 1 of 2

**Motorola Solutions Inc.
EME Test Laboratory**

Motorola Solutions Malaysia Sdn Bhd
Plot 2A, Medan Bayan Lepas,
Mukim 12 SWD 11900 Bayan Lepas Penang, Malaysia.

Date of Report: 08/04/2022
Report Revision: B

Responsible Engineer: Saw Sun Hock (EME Engineer)
Report author: Sin Keng LEE (EME Engineer)
Date(s) Tested: 2/17/2017-3/17/2017, 1/25/2021 - 2/4/2021
Manufacturer: Futurecom Systems Group (DVR), Motorola Solutions. Inc (Mobile)
Date submitted for test: 01/13/2017; 01/22/2021
DUT Description: **APX 6500 8/900MHz:** Multiple HW Encryption WiFi Interoperability Data Modem Tethering via WiFi or Cable
Companion Device: DVR 700 (764-776 MHz; 794-806MHz), Digital Vehicular Repeater CW
Test TX mode(s):
Max. Power output: Refer to Table 6
TX Frequency Bands: Refer to Table 6
Signaling type: FM, TDMA, FHSS (Bluetooth), 802.11b/g/n (WLAN 2.4 GHz), 802.11 a/n/ac (WLAN 5 GHz)
Model(s) Tested: **APX 6500 8/900MHz:** M25VRS9PW1CN (PMUF1980A)
Companion Device: MOBEXCOM DVRS 700 (DQPM DVRS7000P)
Model(s) Certified: M25VRS9PW1CN (PMUF1980A), M22VRS9PW1CN (PMUF1980A), MOBEXCOM DVRS 700 (DQPM DVRS7000P)
Serial Number(s): 471TX81927 (APX 6500 8/900MHz) , 16092663 (DVR 700)
Classification: Occupational/Controlled Environment
Applicant Name: Motorola Solutions Inc.
Applicant Address: 8000 West Sunrise Boulevard, Fort Lauderdale, Florida 33322
FCC ID: **APX 6500 8/900MHz:** AZ492FT7141 (806-824 MHz, 851-869 MHz, 896-901 MHz, 935-940 MHz, Bluetooth 2402-2480 MHz, WLAN 2412-2462 MHz; WLAN 5180-5825 MHz)
Companion Device: LO6-DVRS700 (769-775 MHz; 799-806MHz)
IC: **APX 6500 8/900MHz:** 109U-92FT7141
Companion Device: 2098B-DVRS700
This report contains results that are immaterial for FCC equipment approval, which are clearly identified.
This report contains results that are immaterial for ISED Canada equipment approval, which are clearly identified.

The MPE results clearly demonstrate compliance with FCC Occupational/Controlled RF Exposure limits. FCC rules require compliance for Passengers and Bystanders to the FCC General Population/Uncontrolled limits. The test results clearly demonstrate compliance with Health Canada Safety Code 6 (2015). Limits of Human Exposure to Radio frequency Electromagnetic Energy in the Frequency Range from 3 kHz to 300 GHz.

Based on the information and the testing results provided herein, the undersigned certifies that when used as stated in the operating instructions supplied, said product complies with the national and international reference standards and guidelines listed in section 4.0 of this report (no deviation from standard methods). This report shall not be reproduced without written approval from an officially designated representative of the Motorola Solutions Inc. EME Laboratory. I attest to the accuracy of the data and assume full responsibility for the completeness of these measurements. This reporting format is consistent with the suggested guidelines of the TIA TSB-159 April 2006. The results and statements contained in this report pertain only to the device(s) evaluated herein.

Saw Sun Hock (Approved Signatory)
Approval Date: 8/9/2022

Document Revision History

Date	Revision	Comments
04/24/2022	A	Initial release
08/04/2022	B	Update the Model Name

Table of Contents

Part 1 of 2

1.0 Introduction 5

2.0 FCC MPE Summary..... 5

3.0 Abbreviations / Definitions 5

4.0 Referenced Standards and Guidelines..... 6

5.0 Power Density Limits 6

6.0 N_c Test Channels 9

7.0 Measurement Equipment 9

8.0 Measurement System Uncertainty Levels 9

9.0 Product and System Description 10

10.0 Additional Options and Accessories..... 11

11.0 Test Set-Up Description 11

12.0 Method of Measurement with trunk mounted antenna(s)..... 12

 12.1 External/Bystander vehicle MPE measurements 12

 12.2 Internal/Passenger vehicle MPE measurements 12

13.0 Method of Measurement APX 6500 8/900MHz Mobile radio with roof mounted antenna(s)..... 13

 13.1 External/Bystander vehicle MPE measurements 13

 13.2 Internal/Passenger vehicle MPE measurements 13

14.0 MPE Variability Requirement for External/Bystander vehicle MPE measurement..... 14

15.0 MPE Calculations..... 14

16.0 Antenna Summary 15

17.0 Test Results Summary 16

 17.1 MPE Test Results Summary for APX 6500 8/900MHz Mobile radio and DVR 700 16

 17.2 MPE Test Results for Bluetooth and WLAN 17

 17.3 Simultaneous Transmission..... 19

18.0 Conclusion 21

19.0 User Instructions Considerations 22

Appendix A - Antenna Locations, Test Distances, and Cable Losses 23

Appendix B - Probe Calibration Certificates 29

Appendix C - Photos of Assessed Antennas..... 39

Part 2 of 2

Appendices

Appendix D – MPE Test Results Summary for APX 6500 8/900MHz..... 2
Appendix E – MPE Test Results Summary for Companion Device (DVR 700) 16
Appendix F – MPE Measurement Results for APX 6500 8900MHz 20
Appendix G – MPE Measurement Results for Companion Device (DVR 700)..... 35

1.0 Introduction

This report details the test setup, test equipment and test results of Maximum Permissible Exposure (MPE) performed at Motorola Solutions’ outside test site for APX 6500 8/900MHz M25VRS9PW1CN (PMUF1980A) and Companion Device DVRS 700 (FCC ID: LO6-DVRS700).

2.0 FCC MPE Summary

Table 1

APX 6500 8/900MHz (FCC ID: AZ492FT7141)					
Roof Mounted Antenna					
Equipment Class	Frequency Band (MHz)	Passenger		Bystander	
		Power Density (mw/cm²)	Highest % of Limit	Power Density (mw/cm²)	Highest % of Limit
TNB	LMR 8/900MHz (806-824, 851-869; 896-901, 935-940)	0.035	6.40%	0.033	6.20%
DTS	WLAN (2412-2462)	0.018	1.77%	0.018	1.77%
NII	WLAN (5180-5825)	0.007	0.67%	0.007	0.67%
DSS	BT (2402-2480)	0.005	0.50%	0.005	0.50%
Companion Device DVRS 700 (FCC ID: LO6-DVRS700)					
Trunk Mounted Antenna					
Equipment Class	Frequency Band (MHz)	Passenger		Bystander	
		Power Density (mw/cm²)	Highest % of Limit	Power Density (mw/cm²)	Highest % of Limit
TNB	769-775; 799-806	0.038	7.3%	0.020	3.9%
Simultaneous Transmissions					
Simultaneous Transmissions conditions		Passenger		Bystander	
		Highest Combine % of limit		Highest Combine % of limit	
APX 6500 (8/900MHz) + WLAN + DVR 700		15.47%		11.87%	

3.0 Abbreviations / Definitions

- CNR: Calibration Not Required
- CW: Continuous Wave
- DUT: Device Under Test
- EME: Electromagnetic Energy
- FHSS: Frequency Hopping Spread Spectrum
- FM: Frequency Modulation
- MPE: Maximum Permissible Exposure
- GPS: Global Positioning System
- LMR: Land Mobile Radio
- SAR: Specific Absorption Rate
- NA: Not Applicable

BS: Bystander
 PB: Passenger Back seat
 PF: Passenger Front seat
 PTT: Push to Talk
 WLAN: Wireless Local Area Network
 TDMA: Time Division Multiple Access

4.0 Referenced Standards and Guidelines

This product is designed to comply with the following applicable national and international standards and guidelines.

- United States Federal Communications Commission, Code of Federal Regulations; Rule Part 47CFR § 1.1310, § 2.1091 (d) and § 2.1093 for RF Exposure, where applicable.
- Federal Communications Commission, “Evaluating Compliance with FCC Guidelines for Human Exposure to Radio frequency Electromagnetic Fields”, OET Bulletin 65 (Edition 97-01), FCC, Washington, D.C.: August 1997.
- Institute of Electrical and Electronics Engineers (IEEE) C95.1-2019
- American National Standards Institute (ANSI) / Institute of Electrical and Electronics Engineers (IEEE) C95. 1-1992. Specific to FCC rules and regulations.
- Institute of Electrical and Electronics Engineers (IEEE) C95.3-2002
- International Commission on Non-Ionizing Radiation Protection (ICNIRP) 1998
- Ministry of Health (Canada) Safety Code 6 (2015), Limits of Human Exposure to Radio frequency Electromagnetic Fields in the Frequency Range from 3 kHz to 300 GHz
- RSS-102 (Issue 5) – Radio Frequency (RF) Exposure Compliance of Radio communication Apparatus (All Frequency Bands)
- FCC KDB – 447498 D01 General RF Exposure Guidance v06
- FCC KDB – 865664 D02 RF Exposure Reporting v01r02

5.0 Power Density Limits

Table 2 – Occupational / Controlled Exposure Limits

Frequency Range (MHz)	FCC OET Bulletin 65/ 47CFR § 1.1310	ICNIRP	IEEE C95.1 2019	RSS-102 Issue 5 2015
	mW/cm ²			
10 – 20				10.0
20 – 48				44.72 / f ^{0.5}
30 – 300	1.0			
48 – 100				6.455
10 – 400		10.0		
100 – 400			10.0	
100 – 6,000				0.6455 f ^{0.5}
300 – 1,500	f/300			

Table 2 – Occupational / Controlled Exposure Limits (Con’t.)

Frequency Range (MHz)	FCC OET Bulletin 65/ 47CFR § 1.1310	ICNIRP	IEEE C95.1 2019	RSS-102 Issue 5 2015
	mW/cm ²	W/m ²	W/m ²	W/m ²
400 – 2,000		f/40	f/40	
1,500 – 100,000	5.0			
2,000 – 300,000		50.0	50.0	
6,000 – 15,000				50.0
15000 – 150,000				50.0
150000 – 300,000				$3.33 \times 10^{-4} f$

Table 3 – General Population / Uncontrolled Exposure Limits

Frequency Range (MHz)	FCC OET Bulletin 65/ 47CFR § 1.1310	ICNIRP	IEEE C95.1 2019	RSS-102 Issue 5 2015
	mW/cm ²	W/m ²	W/m ²	W/m ²
10 – 20				2.0
20 – 48				$8.944 / f^{0.5}$
30 – 300	0.2			
48 – 300				1.291
10 – 400		2.0		
100 – 300				
100 – 400			2.0	
300 – 1,500	f/1,500			
300 – 6000				$0.02619 f^{0.6834}$
400 – 2,000		f/200	f/200	
1,500 – 100,000	1.0			
2,000 – 300,000		10.0	10.0	
6,000 – 15,000				10.0
15,000 – 150,000				10.0
150,000 – 300,000				$6.67 \times 10^{-5} f$

6.0 N_c Test Channels

The number of test channels is determined by using Equation 1 below. This equation is available in FCC’s KDB 447498. The test channels are appropriately spaced across the antenna’s frequency range.

Equation 1 – Number of test channels

$$N_c = \text{Round} \{ [100(f_{\text{high}} - f_{\text{low}})/f_c]^{0.5} \times (f_c / 100)^{0.2} \}$$

where N_c is the number of test channels, f_{high} and f_{low} are the highest and lowest frequencies within the transmission band, f_c is the mid-band frequency, and frequencies are in MHz.

7.0 Measurement Equipment

Table 4 – Equipment

Equipment Type	Model #	SN	Calibration Date	Calibration Due Date
Automobile	Volvo 240-1988	NA	NA	NA
Survey Meter (LMR test)	ETS Model HI-2200	00086887	05/06/2020	05/06/2021
Probe – E-Field (LMR test)	ETS Model E100	00224511	05/06/2020	05/06/2021
Survey Meter (DVR test)	ETS Model HI-2200	00086316	05/16/2016	05/16/2017
Probe – E-Field (DVR test)	ETS Model E100	00153632	05/16/2016	05/16/2017
Probe – H-Field (DVR test)	ETS Model H200	00206937	05/16/2016	05/16/2017

E-field measurements are in mW/cm².

H field measurements are in A/m.

8.0 Measurement System Uncertainty Levels

Table 5 – Uncertainty Budget for Near Field Probe Measurements

	Tol. (± %)	Prob. Dist.	Divisor	u_i (±%)		v_i
Measurement System						
Probe Calibration	7.1	N	1.00	7.1	50.4	∞
Survey Meter Calibration	0.0	N	1.00	0.0	0.0	∞
Hemispherical Isotropy	8.0	R	1.73	4.6	21.33	∞
Linearity	5.0	R	1.73	2.9	8.33	∞
Pulse Response	1.0	R	1.73	0.6	0.33	∞
RF Ambient Noise	3.0	R	1.73	1.7	3.00	∞
RF Reflections	8.0	R	1.73	4.6	21.33	∞
Probe Positioning	10.0	R	1.73	5.8	33.333	∞
Test sample Related					0.00	
Antenna Positioning	3.0	N	1.00	3.0	9.0	∞
Power drift	5.0	R	1.73	2.9	8.33	∞
Bystander measurement uncertainty	4.8	N	1.00	4.8	23.04	∞
Passenger measurement uncertainty	8.1	N	1.00	8.1	65.61	∞
Combined Standard Uncertainty		RSS		15.6	15.6	∞
Expanded Uncertainty (95% CONFIDENCE LEVEL)		$k=2$		31	31	

9.0 Product and System Description

APX 6500 8/900MHz operates in the LMR bands using either frequency modulation (FM) with 100% transmit duty cycle or TDMA signals with maximum of 50% transmit duty cycle. For conservative assessment, FM signal was tested. A duty factor of 50% applies for PTT operation mode.

This device also incorporates a Class 1 Bluetooth device which is a Frequency Hopping Spread Spectrum (FHSS) technology. The Bluetooth radio modem is used to wireless link audio accessories. The maximum actual transmission duty cycle is imposed by the Bluetooth standard. The maximum duty cycle for BT is 100%. Bluetooth Low Energy (BT LE) intended to reduce power consumption.

This device also contains WLAN technology for data capabilities over 802.11b/g/n 2.4 GHz and 802.11 a/n/ac 5 GHz wireless networks.

MOBEXCOM DVR 700 is Digital Vehicular Repeater (DVR) manufactured by Futurecom System Group. At standalone the DVR operates at a maximum power up to 20W, but when the DVR is interfaced to the APX 6500 8/900MHz Mobile radio, the maximum power is 5W as listed in Table 6. For more detailed information refer to the Product Safety and RF Energy Exposure Booklet for DVR.

Table 6 below summarizes the technologies, bands, maximum duty cycles and maximum output powers. Maximum output powers are defined as upper limit of the production line final test station.

Table 6 – Bands, Duty Cycle and Maximum Power

Technologies	Bands (MHz)	Duty Cycle (%)	Max Power (W)
APX 6500 (8/900MHz)	806-825, 851-870	50 (PTT)	42W
	896-901; 935-940	50 (PTT)	36W
	901-902; 940-941	50 (PTT)	4W
	BT 2402-2480	100	11.2mW
	BT LE 2402-2480	100	6.3mW
	WLAN 2412 – 2462 (802.11b/g/n)	100	39.8mW (802.11b)
			7.079mW (802.11g – Channel 1 and 11), 15.8mW (802.11g – Channel 2-10)
			7.079mW (802.11n – Channel 1 and 11), 12.58mW (802.11n – Channel 2-10)
WLAN 5180-5825 (802.11 a/n/ac)	100	15.84mW	
DVR 700	764-776; 794-806	100	5

This test report covers the RF exposure performance of the APX 6500 8/900MHz FCC ID: AZ492FT7141 interfaced with, and transmitting simultaneously with Companion device (DVR 700) FCC ID: LO6-DVRS700. DVR operate in repeater; transmit with duty cycle up to 100%. A duty factor of 50% applies for APX 6500 8/900MHz with PTT operating mode.

Table 7 lists the simultaneous transmission conditions.

Table 7 – Simultaneous transmission conditions

Simultaneous transmission conditions	APX 6500 8/900MHz	DVR 700
APX 6500 8/900MHz + DVR 700	x	x

Note: 'x' Simultaneous transmitting antennas

This device will be marketed to and used by employees solely for work-related operations. User training is the responsibility of the organizations that employ the individuals using the occupational device. The Product Safety and RF Energy Exposure Booklet for Digital Vehicular Repeater Systems (DVRS) contains all the information necessary to inform the organization and its employees in safe usage and for creating training materials or conducting instructional sessions for those employees.

Accordingly this product is classified as Occupational/Controlled Exposure. However, in accordance with FCC requirements, the passengers inside the vehicle and the bystanders external to the vehicle are evaluated to the General Population/Uncontrolled Exposure Limits.

(Note that “Bystanders” as used herein are people other than operator)

10.0 Additional Options and Accessories

Not available.

11.0 Test Set-Up Description

Assessments were performed with APX 6500 8/900MHz Mobile radio and Companion device (DVR 700) installed in the test vehicle, at the specified distances and test locations indicated in sections 12.0, 13.0 and Appendix A.

All antennas described in Table 8 were considered in order to develop the test plan for this product. Antennas were installed and tested per their appropriate mount locations (Roof / Trunk) and defined test channels. The DVR antenna mounted at center of the trunk (for external/bystander measurement) or toward the center of the trunk at a minimum 85 cm from backseat passenger (for Internal/passenger measurement), and the APX 6500 8/900MHz Mobile radio antennas are mounted at the center of the roof.

The system was tested using a low-loss 16’ Teflon RG58A/U cable attaching the radio to the transmit antenna. This cable is shorter and lower attenuation than the 17’ RG58A/U cables supplied in the customer kits for connecting the radio to the transmit antenna. The cable used in the test setup also has lower attenuation over the test frequency range than the cable provided in the customer kits. The use of a shorter cable with lower attenuation in the test setup ensures that the test data is more conservative with regards to the actual installation. Cable losses are reported in Appendix A.

12.0 Method of Measurement with trunk mounted antenna(s)

12.1 External/Bystander vehicle MPE measurements

Initially the DVR antenna is located at the center of the trunk. Refer to Appendix A for antenna location and distance.

MPE measurements for bystander (BS) conditions are determined by taking the average of (10) measurements in a 2 m vertical line for each of the (5) bystander test locations indicated in Appendix A with 20 cm height increments, with the distance of 90cm from the test vehicle's body, as stated in the user manual. The measurement probe is positioned orthogonal to antenna (typically parallel to ground with a vertically mounted antenna) and aimed directly at the antenna's axis. These measurements are representative of persons other than the operator standing next to the vehicle.

12.2 Internal/Passenger vehicle MPE measurements

The DVR antenna is located toward the center of the trunk at a minimum 85 cm from backseat passenger. Refer to Appendix A for antenna location and distance.

MPE measurements for passenger front seat (PF) and backseat (PB) conditions are determined by taking the average of the (3) measurements (Head, Chest, and Lower Trunk) inside the vehicle for both the front and back seats.

The backseat is a bench seat and therefore each position (Head, Chest & Lower Trunk) were scanned across (horizontally) the seat starting from the middle of the seat to the edge of the seat stopping 20 cm from the vehicle door. Similar process was used in the front bucket seat.

The probe handle is oriented parallel (horizontal) to the ground and pointed towards the back of the vehicle. The probe handle is not oriented normal to the seat surface. The probe head (incorporating the field sensors) is scanned continuously (using the max-hold function available in the meter) along three test axes which are parallel to the seat angle (intended as the line determined by the intersection of the plane of the seat and the plane of the backrest) and are 20 cm from the seat surface. One test axis is at the Head height, another is at the Chest height, and another is at the Lower Trunk height. The maximum field level value recorded for each test axis is logged. The MPE is determined by averaging these three maximum values regardless of the geometrical location where they were observed. For instance, the locations of the three maxima may lie on different vertical (relative to ground) lines.

This approach leads to results that are representative of the exposure of vehicle occupants since it is based on an average across the body portions closest to the antenna for trunk mount positions, and is conservatively biased because the highest results for each test axis are combined, e.g. the highest head exposure could be in the middle of the seat while the highest lower trunk exposure could be closer to the door.

13.0 Method of Measurement APX 6500 8/900MHz Mobile radio with roof mounted antenna(s)

The installation requirements for this radio indicate that in multiple single-band antenna configurations and the antennas should be installed at the center of the roof.

13.1 External/Bystander vehicle MPE measurements

Antenna is located at the center of the roof. (Refer to Appendix A for antenna location and distance)

MPE measurements for bystander (BS) conditions are determined by taking the average of (10) measurements in a 2m vertical line for each of the (5) bystander test locations indicated in Appendix A with 20 cm height increments at the test distance of 90cm from the test vehicle body.

The measurement probe is positioned orthogonal to antenna (typically parallel to ground with a vertically mounted antenna) and aimed directly at the antenna's axis. These measurements are representative of persons other than the operator standing next to the vehicle.

13.2 Internal/Passenger vehicle MPE measurements

Antenna is located at the center of the roof. (Refer to Appendix A for antenna location and distance)

MPE measurements for passenger front seat (PF) and backseat (PB) conditions are determined by taking the average of the (3) measurements (Head, Chest, and Lower Trunk) inside the vehicle for both the front and back seats.

The backseat is a bench seat and therefore each position (Head, Chest & Lower Trunk) were scanned across (horizontally) the seat starting from the middle of the seat to the edge of the seat stopping 20 cm from the vehicle door. Similar process was used in the front bucket seat.

The probe handle is oriented parallel (horizontal) to the ground and pointed towards the back of the vehicle. The probe handle is not oriented normal to the seat surface. The probe head (incorporating the field sensors) is scanned continuously (using the max-hold function available in the meter) along three test axes which are parallel to the seat angle (intended as the line determined by the intersection of the plane of the seat and the plane of the backrest) and are 20 cm from the seat surface. One test axis is at the Head height, another is at the Chest height, and another is at the Lower Trunk height. The maximum field level value recorded for each test axis is logged. The MPE is determined by averaging these three maximum values regardless of the geometrical location where they were observed. For instance, the locations of the three maxima may lie on different vertical (relative to ground) lines.

This approach leads to results that are representative of the exposure of vehicle occupants since it is based on an average across the body portions closest to the antenna for both trunk and roof mount positions, and is conservatively biased because the highest results for each test axis are combined, e.g. the highest head exposure could be in the middle of the seat while the highest lower trunk exposure could be closer to the door.

14.0 MPE Variability Requirement for External/Bystander vehicle MPE measurement

If all the MPE bystander measurements for a particular antenna are below 50% of the FCC MPE limit, no variability testing for that antenna is required.

If one or more MPE bystander measurements for a particular is between 50-80% of the FCC MPE limit, with no results > 80%, variability testing shall be done on the single worst case for that antenna.

For any MPE bystander measurement above 80% of the FCC MPE limit, variability testing shall be done for all of such configuration. When SAR simulation is performed for a particular antenna configuration to determine compliance, variability measurements are not required for that antenna configuration.

15.0 MPE Calculations

The final MPE results for APX 6500 8/900MHz Mobile radio and Companion device (DVR 700) are presented in section 17.0. These results are based on 50% duty cycle for APX 6500 8/900MHz (PTT operation) and 100% duty cycle for DVR 700 (repeater operation).

Below is an explanation of how the MPE results are calculated. Refer to Appendix F for APX 6500 8/900MHz; Appendix G for Companion device (DVR 700).

External to vehicle (Bystander) - 10 measurements are averaged over the body (*Avg_over_body*).
Internal to vehicle (Passengers) - 3 measurements are averaged over the body (*Avg_over_body*).

The Average over Body test methodology is consistent with IEEE/ANSI C95.3-2002 guidelines.

Therefore;

Equation 2 – Power Density Calculation (*Calc. P.D.*)

$$\text{Calc. P.D.} = (\text{Avg_over_body}) * (\text{probe_frequency_cal_factor}) * (\text{duty_cycle})$$

Note 1: The highest “average” cal factors from the calibration certificates were selected for the applicable frequency range. Linear interpretation was used to determine “probe_frequency_cal_factor” for the specific test frequencies.

Note 2: The E-field probe calibration certificate’s frequency cal factors were determined by measuring V/m. The survey meter’s results were measured in power density (mW/cm²) and therefore the “probe_frequency_cal_factor” was squared in equation 2 to account for these results.

Note 3: The H-field probe calibration certificate’s frequency cal factors were determined by measuring A/m. The survey meter’s results were measured in A/m and therefore the “Avg_over_body” A/m results were converted to power density (mW/cm²) using the equation 3. H-field measurements are only applicable to frequencies below 300MHz.

Equation 3 – Converting A/m to mW/cm²

$$mW/cm^2 = (A/m)^2 * 37.699$$

Equation 4 – Power Density Maximum Calculation

$$Max_Calc_P.D. = P.D._calc * \frac{max_output_power}{initial_output_power}$$

Note 4: For initial output power > max_output_power; max_output_power / initial output power = 1

16.0 Antenna Summary

Table below summarizes the tested or evaluated antennas and their descriptions, mount location (roof/trunk), overlap of FCC bands, number of test channels per FCC KDB 447498 (FCC N_c). This information was used to determine the test configurations presented in this report.

Table 8

Antenna No.	Antenna Model	Frequency Range (MHz)	Physical Length (cm)	Gain (dBi)	Remarks	Mount Location (Roof/ Trunk)	Overlap FCC Bands (MHz)	FCC N _c
APX 6500 8/900MHz								
1	HAF4013A	806 - 941	6.1	5.15	1/4 wave	R/T	806-941	14
2	HAF4036A	806 - 941	8.4	2.14	1/4 wave	R/T	806-941	14
3	HAF4037A	806 - 941	28.5	3.00	1/2 wave	R/T	806-941	14
BT/WLAN								
4	PMAN5100A	2400-2500	5.7 (L) x 1.9 (W)	3.0		Glass mount	2412-2462	3
5	PMAN5101A	2400-2500 / 4900-5900	5.4 (L) x 1.32 (W)	2.7 / 0.2		Glass mount	2412-2462 ; 5180-5825	3
6	AN000163A01	2400-2500 / 4900-5900	7	3.5 / 3.3	Monopole	Roof/ Trunk	2412-2462 ; 5180-5825	3
7	AN000163A05	2400-2500 / 4900-5900	7	2.5 / 1.6	Monopole	Roof/ Trunk	2412-2462 ; 5180-5825	3
DVR 700								
8	HAF4016A	764-870	9	2.15	1/4 wave	Trunk	769-775; 799-806	4

17.0 Test Results Summary

17.1 MPE Test Results Summary for APX 6500 8/900MHz Mobile radio and DVR 700

Refer to the following appendices for MPE test results for each test configuration: antenna location, test positions (BS1-Bystander test location #1, BS2-Bystander test location #2, BS3-Bystander test location #3, BS4-Bystander test location #4, BS5-Bystander test location #5, PB-Passenger Backseat, PF-Passenger Front seat), E/H field measurements, antenna model & freq. range, maximum output power, initial power, TX frequency, max calculated power density results, applicable specification limits and % of the applicable specification limits.

- Appendix D for APX 6500 8/900MHz
- Appendix E for Companion Device (DVR 700)

Table 9 summarized the highest maximum calculated power density and highest % of the applicable specification limit for each standalone transmitters (APX 6500 8/900MHz Mobile radio and DVR 700).

Table 9

Test Positions	APX 6500 8/900MHz (FCC ID: AZ492FT7141)		DVR 700 (FCC ID: LO6-DVRS700)	
	Power Density (mw/cm ²)	Highest % of Limit	Power Density (mw/cm ²)	Highest % of Limit
FCC US				
Passenger, Front Seat (PF)	0.025	4.6%	0.03	6.1%
Passenger, Back Seat (PB)	0.035	6.4%	0.04	7.3%
Bystander #1 (BS-1)	0.033	6.2%	0.004	0.8%
Bystander #2 (BS-2)	0.028	5.2%	0.01	2.1%
Bystander #3 (BS-3)	0.023	4.3%	0.02	3.6%
Bystander #4 (BS-4)	0.020	3.6%	0.02	3.3%
Bystander #5 (BS-5)	0.019	3.5%	0.02	3.9%
ISED Canada				
Passenger, Front Seat (PF)	0.025	9.8%	0.03	12.7%
Passenger, Back Seat (PB)	0.035	13.6%	0.04	15.4%
Bystander #1 (BS-1)	0.033	13.1%	0.004	1.6%
Bystander #2 (BS-2)	0.028	10.9%	0.01	4.5%
Bystander #3 (BS-3)	0.023	9.1%	0.02	7.5%
Bystander #4 (BS-4)	0.020	7.7%	0.02	6.9%
Bystander #5 (BS-5)	0.019	7.4%	0.02	8.1%

17.2 MPE Test Results for Bluetooth and WLAN

Antenna PMAN5100A and PMAN5101A was intended for mounting on the windshield of the vehicle. These antennas should be installed close to the top, and on the front windshield only. Antennas AN000163A01 and AN000163A05 support WLAN 2.4 GHz / 5 GHz should be installed at roof or trunk of the vehicle. WLAN 2.4 GHz and 5 GHz will not transmit simultaneously.

MPE calculation was use to determine power density for these transmitters due to lower power. According to FCC's OET Bulletin 65 Edition 97-01 Section 2, calculations can be made to predict RF field strength and power density levels around typical RF sources. Equation (5) is generally accurate in far-field of an antenna.

Equation 5 – Power Density Calculation

$$S = \frac{P_t G}{4\pi d^2} F$$

Equation (5) accounts for the maximum duty cycle of the signal, and the factor, F, to provide a worst-case prediction of power density per FCC OET Bulletin 65, Edition 97-01 1997.

Where:

- S = power density
- P_t = maximum output power scaled by the maximum duty cycle of the signal
- G = power gain of the antenna in the direction of interest relative to an isotropic radiator
- d = distance from antenna
- F = Enhancement factor [1 or 2.56 for predicting ground-level field strength]

Table 10 summarized the MPE calculation for each standalone transmitter bands, Bluetooth and WLAN.

Table 10

Antenna #	Max Power (W)	Duty Cycle (%)	Tx Frequency (MHz)	Antenna Gain (dBi)	Cable Loss, L (dB)	Dist., d (cm)	⁽⁴⁾ Enhance Factor, F	Max Calc. MPE (mW/cm ²)	MPE Spec Limit (mW/cm ²)					
									FCC	% To FCC Spec Limit	ICNIRP	% To ICNIRP Spec Limit	ISED limit	% To ISED Spec Limit
WLAN 2.4 GHz														
AN000163A01	0.040	100%	2412.0	3.50	0.00	20	1.00	0.018	1.00	1.77	1.00	1.77	0.54	3.30
AN000163A01	0.040	100%	2437.0	3.50	0.00	20	1.00	0.018	1.00	1.77	1.00	1.77	0.54	3.28
AN000163A01	0.040	100%	2462.0	3.50	0.00	20	1.00	0.018	1.00	1.77	1.00	1.77	0.54	3.26
AN000163A05	0.040	100%	2412.0	2.50	0.00	20	1.00	0.014	1.00	1.41	1.00	1.41	0.54	2.62
AN000163A05	0.040	100%	2437.0	2.50	0.00	20	1.00	0.014	1.00	1.41	1.00	1.41	0.54	2.61
AN000163A05	0.040	100%	2462.0	2.50	0.00	20	1.00	0.014	1.00	1.41	1.00	1.41	0.54	2.59
PMAN5100A	0.040	100%	2412.0	3.00	0.00	20	1.00	0.016	1.00	1.58	1.00	1.58	0.54	2.94
PMAN5100A	0.040	100%	2437.0	3.00	0.00	20	1.00	0.016	1.00	1.58	1.00	1.58	0.54	2.92
PMAN5100A	0.040	100%	2462.0	3.00	0.00	20	1.00	0.016	1.00	1.58	1.00	1.58	0.54	2.90
PMAN5101A	0.040	100%	2412.0	2.70	0.00	20	1.00	0.015	1.00	1.47	1.00	1.47	0.54	2.75
PMAN5101A	0.040	100%	2437.0	2.70	0.00	20	1.00	0.015	1.00	1.47	1.00	1.47	0.54	2.73
PMAN5101A	0.040	100%	2462.0	2.70	0.00	20	1.00	0.015	1.00	1.47	1.00	1.47	0.54	2.71
WLAN 5 GHz														
AN000163A01	0.016	100%	5180.0	3.30	0.00	20	1.00	0.007	1.00	0.67	1.00	0.67	0.90	0.75
AN000163A01	0.016	100%	5502.5	3.30	0.00	20	1.00	0.007	1.00	0.67	1.00	0.67	0.94	0.71
AN000163A01	0.016	100%	5825.0	3.30	0.00	20	1.00	0.007	1.00	0.67	1.00	0.67	0.98	0.69
AN000163A05	0.016	100%	5180.0	1.60	0.00	20	1.00	0.005	1.00	0.46	1.00	0.46	0.90	0.50
AN000163A05	0.016	100%	5502.5	1.60	0.00	20	1.00	0.005	1.00	0.46	1.00	0.46	0.94	0.48
AN000163A05	0.016	100%	5825.0	1.60	0.00	20	1.00	0.005	1.00	0.46	1.00	0.46	0.98	0.46
PMAN5101A	0.016	100%	5180.0	0.20	0.00	20	1.00	0.003	1.00	0.33	1.00	0.33	0.90	0.36
PMAN5101A	0.016	100%	5502.5	0.20	0.00	20	1.00	0.003	1.00	0.33	1.00	0.33	0.94	0.35
PMAN5101A	0.016	100%	5825.0	0.20	0.00	20	1.00	0.003	1.00	0.33	1.00	0.33	0.98	0.34
Bluetooth 2.4 GHz														
AN000163A01	0.011	100%	2402.0	3.50	0.00	20	1.00	0.005	1.00	0.50	1.00	0.50	0.54	0.93
AN000163A01	0.011	100%	2441.0	3.50	0.00	20	1.00	0.005	1.00	0.50	1.00	0.50	0.54	0.92
AN000163A01	0.011	100%	2480.0	3.50	0.00	20	1.00	0.005	1.00	0.50	1.00	0.50	0.55	0.91
AN000163A05	0.011	100%	2402.0	2.50	0.00	20	1.00	0.004	1.00	0.40	1.00	0.40	0.54	0.74
AN000163A05	0.011	100%	2441.0	2.50	0.00	20	1.00	0.004	1.00	0.40	1.00	0.40	0.54	0.73
AN000163A05	0.011	100%	2480.0	2.50	0.00	20	1.00	0.004	1.00	0.40	1.00	0.40	0.55	0.73
PMAN5100A	0.011	100%	2402.0	3.00	0.00	20	1.00	0.004	1.00	0.45	1.00	0.45	0.54	0.83
PMAN5100A	0.011	100%	2441.0	3.00	0.00	20	1.00	0.004	1.00	0.45	1.00	0.45	0.54	0.82
PMAN5100A	0.011	100%	2480.0	3.00	0.00	20	1.00	0.004	1.00	0.45	1.00	0.45	0.55	0.81
PMAN5101A	0.011	100%	2402.0	2.70	0.00	20	1.00	0.004	1.00	0.42	1.00	0.42	0.54	0.78
PMAN5101A	0.011	100%	2441.0	2.70	0.00	20	1.00	0.004	1.00	0.42	1.00	0.42	0.54	0.77
PMAN5101A	0.011	100%	2480.0	2.70	0.00	20	1.00	0.004	1.00	0.42	1.00	0.42	0.55	0.76

Notes:

- 1) Distance from antenna (d), 20cm for more conservative estimation.
- 2) Cable loss (L), all cable loss include in antenna gain, so should be 0 dB.
- 3) Enhancement Factor (F), 1 (Ground reflection already factor in during antenna characterization)

17.3 Simultaneous Transmission

APX 6500 8/900MHz will transmit simultaneously with Companion device (DVR 700); refer to Table 7 for all simultaneous transmission conditions.

The combine MPE results for APX 6500 8/900MHz and Companion device (DVR 700) were calculated base on the percent of MPE limit for each applicable test channels according to the formula below. This is due to the signals emitted by each individual transmitter are statistically uncorrelated; the collective compliance of the transmitters is determined by summing the individual ratios between actual measured power density (S) and maximum allowed MPE exposure. Compliance is achieved if the total exposure (T) is less than one.

Formula:

$$T = \frac{S_1}{MPE_1} + \frac{S_2}{MPE_2} + \dots < 1$$

The highest combined power density percentage of the applicable specification limits are indicating in table 11.

Table 11- Highest Combine MPE % of limits

Test Positions	APX 6500 8/900MHz (FCC ID: AZ492FT7141)		DVR 700 (FCC ID: LO6-DVRS700)	APX 6500 + WLAN + DVR 700	
	806-941 MHz	WLAN	700 MHz Band		
	[1] Highest % of Limit	[2] Highest % of Limit	[3] Highest % of Limit	[1]+[2]+[3] Combine % of Limit	Table No.
FCC US					
Passenger, Front Seat (PF)	4.60%	1.77%	6.1%	12.47%	-
Passenger, Back Seat (PB)	6.40%	1.77%	7.3%	15.47%	-
Bystander #1 (BS-1)	6.20%	1.77%	0.8%	8.77%	-
Bystander #2 (BS-2)	5.20%	1.77%	2.1%	9.07%	-
Bystander #3 (BS-3)	4.30%	1.77%	3.6%	9.67%	-
Bystander #4 (BS-4)	3.60%	1.77%	3.3%	8.67%	-
Bystander #5 (BS-5)	3.50%	1.77%	3.9%	9.17%	-
ISED Canada					
Passenger, Front Seat (PF)	9.8%	3.3%	12.7%	25.80%	-
Passenger, Back Seat (PB)	13.6%	3.3%	15.4%	32.30%	-
Bystander #1 (BS-1)	13.1%	3.3%	1.6%	18.00%	-
Bystander #2 (BS-2)	10.9%	3.3%	4.5%	18.70%	-
Bystander #3 (BS-3)	9.1%	3.3%	7.5%	19.90%	-
Bystander #4 (BS-4)	7.7%	3.3%	6.9%	17.90%	-
Bystander #5 (BS-5)	7.4%	3.3%	8.1%	18.80%	-

18.0 Conclusion

The assessment for APX 6500 8/900MHz and Companion device (DVR 700) were performed as indicates in section 17.1 with an output power range listed in Table 6. The maximum allowable output power is equal to the upper limit of the final test factory transmit power specification listed in Table 6. The highest power density results for APX 6500 8/900MHz and Companion device (DVR 700) scaled to maximum allowable power output are indicated in Table 14 (FCC US) and Table 15 (ISED Canada) for internal/passenger of to the vehicle, and external/bystander to the vehicle.

These MPE results herein demonstrate compliance to FCC Occupation/Controlled Exposure limit. However, FCC rules required compliance for Passengers and Bystanders to FCC General Population / Uncontrolled limits. Maximum Combined MPE percentage in bold exceed General Population / Uncontrolled limit.

Table 12 – Maximum MPE RF Exposure Summary (FCC US)

APX 6500 8/900MHz (FCC ID: AZ492FT7141)					
Roof Mounted Antenna					
Equipment Class	Frequency Band (MHz)	Passenger		Bystander	
		Power Density (mw/cm²)	Highest % of Limit	Power Density (mw/cm²)	Highest % of Limit
TNB	LMR 8/900MHz (806-824, 851-869; 896-901, 935-940)	0.035	6.40%	0.033	6.20%
DTS	WLAN (2412-2462)	0.018	1.77%	0.018	1.77%
NII	WLAN (5180-5825)	0.007	0.67%	0.007	0.67%
DSS	BT (2402-2480)	0.005	0.50%	0.005	0.50%
Companion Device DVR 700 (FCC ID: LO6-DVRS700)					
Trunk Mounted Antenna					
Equipment Class	Frequency Band (MHz)	Passenger		Bystander	
		Power Density (mw/cm²)	Highest % of Limit	Power Density (mw/cm²)	Highest % of Limit
TNB	769-775; 799-806	0.038	7.3%	0.020	3.9%
Simultaneous Transmissions					
Simultaneous Transmissions conditions		Passenger		Bystander	
		Highest Combine % of limit		Highest Combine % of limit	
APX 6500 (8/900MHz) + WLAN + DVR 700		15.47%		11.87%	

Table 13 – Maximum MPE RF Exposure Summary (ISED Canada)

APX 6500 8/900MHz band (IC: 109U-92FT7141)				
Roof Mounted Antenna				
Frequency Band (MHz)	Passenger		Bystander	
	Power Density (mw/cm²)	Highest % of Limit	Power Density (mw/cm²)	Highest % of Limit
LMR 8/900MHz (806-824, 851-869; 896-901, 935-940)	0.035	13.6%	0.033	13.1%
2.4GHz WLAN (2412-2462)	0.018	3.3%	0.018	3.3%
5GHz WLAN (5180 - 5825)	0.007	0.8%	0.007	0.8%
BT (2402-2480)	0.005	0.9%	0.005	0.9%
Companion Device DVR 700 (IC: 2098B-DVRS700)				
Trunk Mounted Antenna				
Frequency Band (MHz)	Passenger		Bystander	
	Power Density (mw/cm²)	Highest % of Limit	Power Density (mw/cm²)	Highest % of Limit
768-775; 798-806	0.038	15.4%	0.020	8.1%
Simultaneous Transmissions				
Simultaneous Transmissions conditions	Passenger		Bystander	
	Highest Combine % of limit		Highest Combine % of limit	
APX 6500 (8900MHz) + WLAN + DVR 700	32.3%		24.5%	

19.0 User Instructions Considerations

In order to facilitate the requirements for occupational exposure limits, the Safety Manual for this radio requires the radio operator to maintain 90 cm in all directions between the vehicle and external persons while transmitting.

Appendix A - Antenna Locations, Test Distances, and Cable Losses

Antenna locations

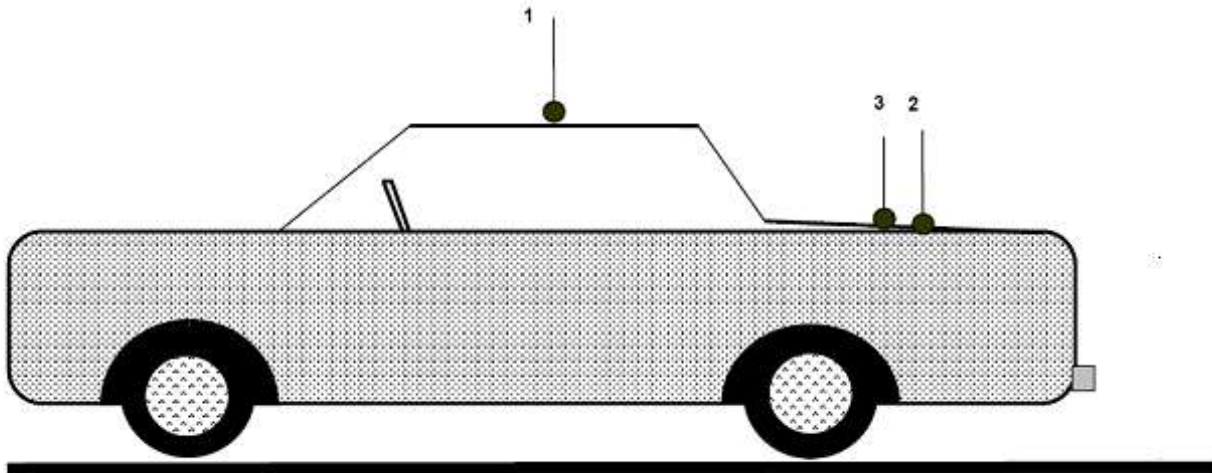

1. Roof (center)
2. Trunk (85cm from back of the back seat)
3. Trunk (center)

Passenger Antenna mounting

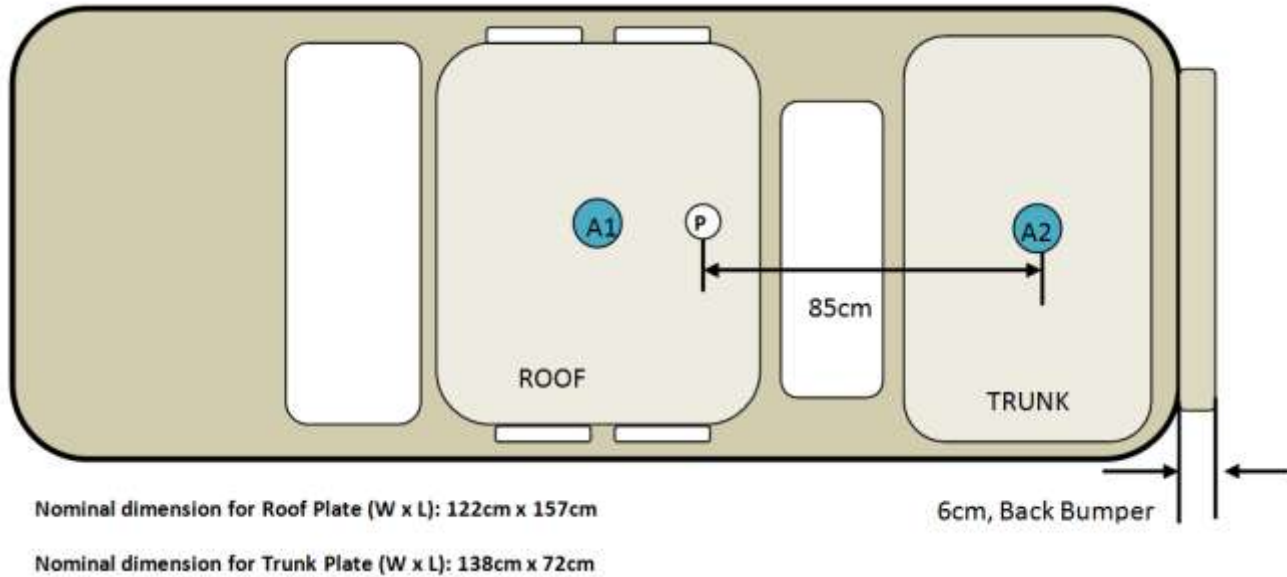

Notes:

- 1.) Antenna location A1: Mobile radio roof antenna mounting locations for front and back passenger testing.
- 2.) Antenna location A2: DVR trunk antenna mounting locations for front and back passenger testing.
- 3.) Total distance between trunk mount antenna and rear passenger is 85cm.

Bystander Antenna mounting

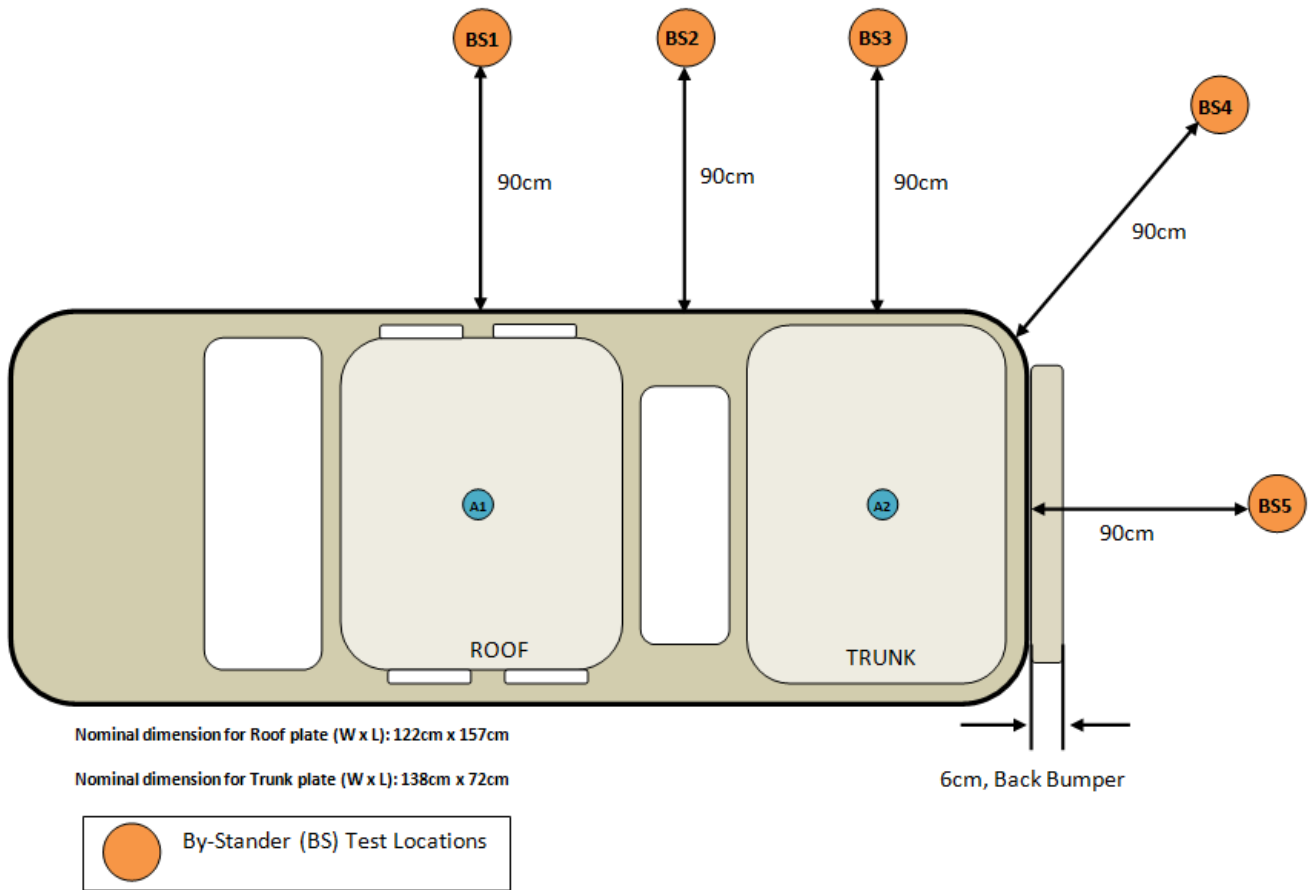

Note:

- 1.) Antenna location A1: Mobile radio roof antenna mounting locations for passenger and bystander testing
- 2.) Antenna location A2: DVR trunk antenna mounting locations for bystander testing
- 3.) Bystander location BS2: Center point of the bystander test location BS1 and test location BS3
- 4.) Bystander location BS (1-5): 90cm away from the vehicle body. Apply for both roof and trunk testing

Seat scan areas (Applicable to both front and back seats)

Meter - Probe

 Probe diameter is 5.5cm

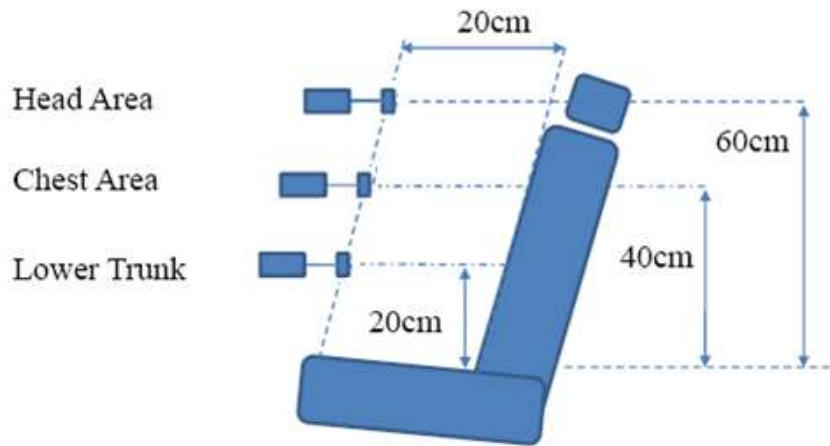

MPE Test Configuration

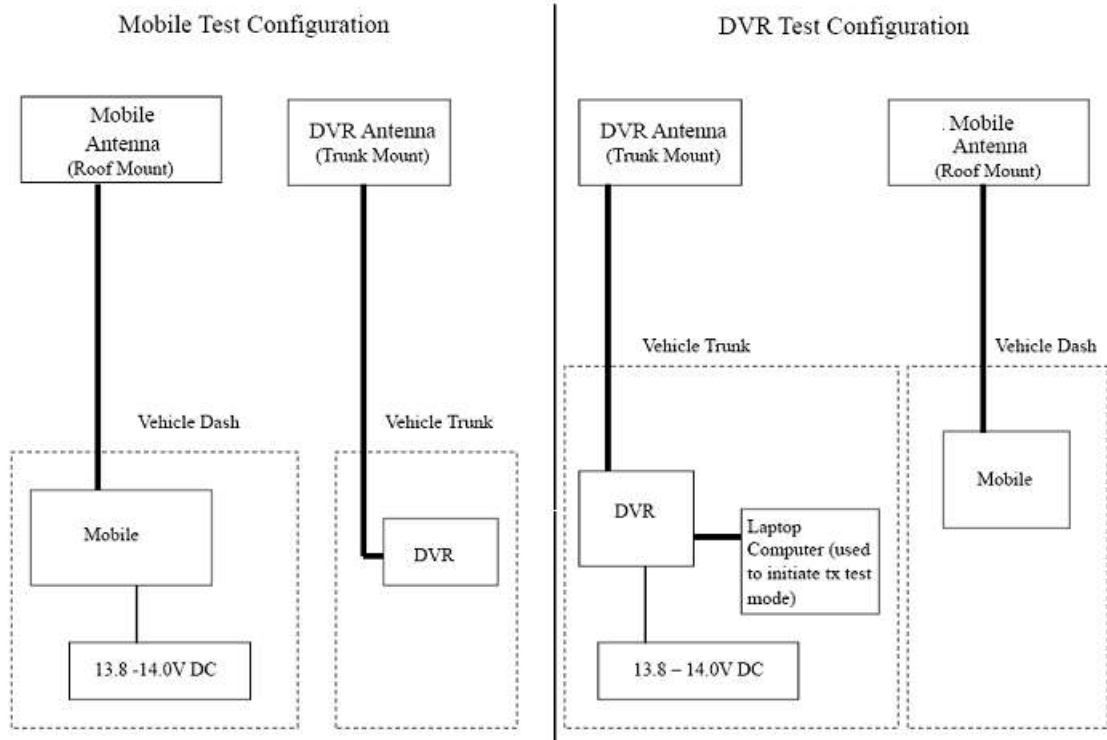

Cable Losses

Test Cable

Teflon RG58A/U Loss Per 100 Feet

160 MHz - 5 dB

450 MHz - 9 dB

1 GHz - 13.8 dB

Customer Cable

RG-58A/U Loss Per 100 Feet (For LMR)

136 MHz – 5.5 dB

450 MHz – 9.6 dB

900 MHz – 13.9 dB

PFP 240 Loss Per 100 Feet (For BT/WLAN)

2500 MHz - 12.9 dB

5800 MHz -20.4 dB

Appendix B - Probe Calibration Certificates

Service Test Report
QAF 1126, 03/11
Report ID: 134653



Certificate of Test Conformance Page 1 of 1

Reference: S 000048638

Customer: Motorola Solutions Malaysia Sdn Bhd - Plot 2A, Medan Bayan Lepas, Mukim 12
S.W.D. - Bayan Lepas - Penang 11900 - Malaysia

The instrument listed below has been tested and verified to Internal Quality Standards. Test data is Attached. Equipment used during instrument testing is controlled by laboratory compliance with ISO/IEC 17025-2017 and ANSI/NCSL Z540-1-1994 using ETS-Lindgren Quality Management System internal procedures.

<u>Manufacturer</u>	ETS-Lindgren	<u>Status In</u>	In Tolerance
<u>Instrument Type</u>	RF Survey Meter	<u>Date Completed</u>	06-May-20
<u>Model</u>	HI-2200	<u>Status Out</u>	Compliant with Internal Quality Standards
<u>Serial Number/ID</u>	00086887		

Remarks

Performed functional test with E100 sn 00224511 and H200 sn 00224521. Unit had Firmware #2.32 Upgrade. Alt ID: MS10201.

I would like to take this opportunity to express our appreciation for using ETS-Lindgren for your EMI test equipment services and I am looking forward to continued business with your organization. Please feel free to contact our offices at (512) 531-6400, if you have any questions regarding this report.

Sincerely,

George Cisneros
Calibration Supervisor

Date Attested: 06-May-20



Cert I.D.: 134651

Certificate of Calibration Conformance

Page 1 of 3

The instrument identified below has been individually calibrated in compliance with the following standard(s):

IEEE 1309 - 2013, Institute of Electrical and Electronics Engineers, Standard for Calibration of Electromagnetic Field Sensors and Probes, Excluding Antennas from 9 kHz to 40 GHz

Environment: Laboratory MTE is maintained in a temperature controlled environment with ambient conditions from 18 to 28 C, relative humidity less than 90%. The instrument under test has been calibrated in a suitable environment using an EMCO TEM Cell 5101C, GTEM 5305/5402 and an RF Shielded EMC Chamber which is conducive to maintaining accurate and reliable measurement quality.

Manufacturer:	ETS-Lindgren	Operating Range:	100kHz - 5GHz
Model Number:	E100	Instrument Type:	Isotropic Probe > 1 GHz
Serial Number/ ID:	00224511	Date Code:	
Tracking Number:	S 000048638	Alternate ID:	MS10428
Date Completed:	06-May-20	Customer:	Motorola Solutions Malaysia Sdn Bhd - Plot 2A, Medan Bayan Lepas, Mukim 12 S.W.D. - Bayan Lepas - Penang 11900 - Malaysia
Test Type:	Standard Field, Field Strength		

Calibration Uncertainty: Std Field Method 100kHz - 6 GHz, +/-0.64 dB, Linearity +/- 0.95 dB, isotropicity +/- 0.86 k=2, (95% Confidence Level)

Test Remarks: Probe received in tolerance thus before and after data are the same. Calibration performed with customer's HI-2200 sn 00066887.

Calibration Traceability: All Measuring and Test Equipment (M/TE) identified below are traceable to the SI units through the National Institute for Standards and Technology (NIST) or other recognized National Metrology Institute. Calibration Laboratory and Quality System controls are compliant with ISO/IEC 17025:2017 and ANSI/NCSL Z540-1-1994.

Standards and Equipment Used:

Make / Model / Name / S/N / Calibration Date				
HP 8648C	Signal Generator	3836U02236	04-May-21	
Keysight E9304A	Power Sensor	MY56100039	16-Apr-21	
Hewlett Packard E4422B	Signal Generator	US40050591	09-Aug-20	
Agilent E9304A	Power Sensor	MY41499013	16-Apr-21	
Agilent E9304A	Power Sensor	MY41499012	16-Apr-21	
Rohde & Schwarz NRP-Z91	Power Sensor	100733	06-Mar-21	
Agilent E4419B	Power Meter	MY40510693	08-Aug-20	
Agilent N1913A	Power Meter	MY50000415	16-Mar-21	
Marconi 2024	Signal Generator	112343/043	04-May-21	
Rohde & Schwarz NRVD	Power Meter	828110/019	09-Jan-21	
Hewlett Packard E4419B	Power Meter	US39250717	14-Aug-20	
Keysight E9304A	Power Sensor	MY56100005	16-Apr-21	
Rohde & Schwarz NRV-Z55	Thermal Power Sensor	100352	20-Sep-20	
Rohde & Schwarz NRV-Z55	Thermal Power Sensor	100037	22-Oct-20	
Rohde & Schwarz NRP-Z91	Power Sensor	100734	01-Aug-20	
Keysight N5183B	MXG Analog Signal Gener	MY53270785	08-Feb-21	

Condition of Instrument

Upon Receipt:
In Tolerance to Internal Quality Standards

On Release:
In Tolerance to Internal Quality Standards

Calibration Completed By
Julio A. Aquino, Calibration Technician

Attested and Issued on 06-May-20
George Camero, Calibration Supervisor

This document provides traceability of measurements to recognized national standards using controlled processes at the ETS-Lindgren Calibration Laboratory. Uncertainties listed are derived from the methods described by NIST Tech Note 1297. This certificate and report may not be reproduced, except in full, without the written approval of ETS-Lindgren Calibration Laboratory in accordance with ISO/IEC 17025:2017 and ANSI/NCSL Z540-1-1994. The results in this document relate only to the item(s) listed and should not be considered representative of a population unless otherwise noted. QAF 1127 (03/11)

CALIBRATION REPORT

Electric Field Sensor

<i>Model</i>	<i>S/N</i>
E100	00224511
HI-2200	00086887

Date: 06 May 2020

- New Instrument
- _ Other
- _ Out of Tolerance
- X Within Tolerance

Frequency Response

<i>Frequency Response</i>	<i>Nominal Field</i>	<i>Cal Factor*</i>	<i>Deviation</i>	
<i>MHz</i>	<i>V/m</i>	<i>(Applied/Indicated)</i>	<i>dB</i>	
1	0.1	20	1.45	-3.22
2	0.5	20	1.12	-1.01
3	1	20	1.05	-0.43
4	3	20	1.00	-0.03
5	15	20	1.00	0.00
6	27.12	20	1.01	-0.05
7	30	20	1.00	-0.04
8	75	20	1.01	-0.07
9	100	20	1.01	-0.11
10	150	20	1.01	-0.10
11	200	20	1.00	-0.03
12	250	20	1.00	-0.04
13	300	20	0.99	0.08
14	400	20	1.01	-0.05
15	500	20	1.05	-0.46
16	600	20	1.05	-0.43
17	700	20	1.08	-0.65
18	800	20	1.10	-0.81
19	900	20	1.05	-0.39
20	1000	20	1.00	0.00
21	2000	20	1.04	-0.32
22	2450	20	1.04	-0.38
23	3000	20	0.96	0.39
24	3500	20	0.90	0.91
25	4000	20	0.99	0.10
26	5000	20	1.01	-0.08
27	5500	20	1.25	-1.93
28	6000	20	1.33	-2.47

* Corrected electric field values (V/m) can be obtained by multiplying the Cal Factor with the indicated E field readings.

Linearity

maximum linearity deviation is 0.42 dB
 (measurements taken from 0.3 V/m to 800 V/m at 27.12 MHz)

Test Conditions

Calibration performed at ambient room temperature: 23 ±3°C



PROBE ROTATIONAL RESPONSE

Model E100
S/N 00224511
Report S00048638
Date Date of Calibration 06 May 2020
Time 08:45:13 AM
Isotropy * + 0.308 dB/ -0.308 dB

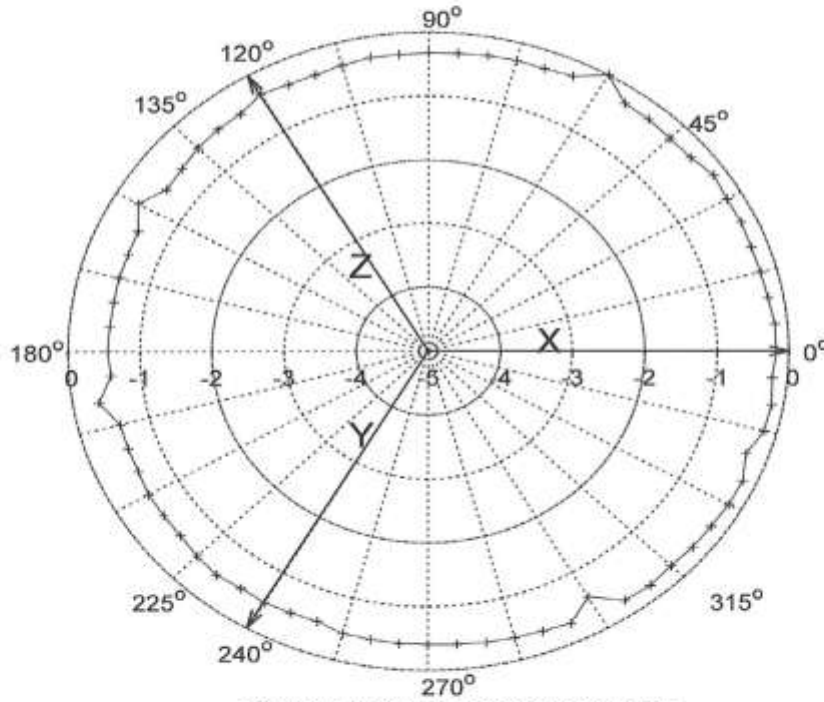

Figure 1: Probe Isotropic Response Chart.

Isotropic response is measured in a 20 V/m field at 400 MHz

*Isotropy is the maximum deviation from the geometric mean as defined by IEEE 1309-2013.

Service Test Report
QAF 1126, 03/11
Report ID: 114201



Certificate of Test Conformance
Page 1 of 1

Reference: S 000035042

Customer: Keysight Cal Lab C/O Motrola Solutions - 8000 West Sunrise Blvd. Plantation, FL. 33322

The instrument listed below has been tested and verified to Internal Quality Standards. Test data is Not Applicable. Equipment used during instrument testing is controlled by laboratory compliance with ISO/IEC 17025-2005 and ANSI/NCCL Z540-1-1994 using ETS-Lindgren Quality Management System internal procedures.

<u>Manufacturer</u>	ETS-Lindgren	<u>Status In</u>	In Tolerance
<u>Instrument Type</u>	RF Survey Meter	<u>Date Completed</u>	16-May-16
<u>Model</u>	HI-2200	<u>Status Out</u>	Compliant with Internal Quality Standards
<u>Serial Number/ID</u>	00086316		

Remarks

Functional test performed with customer's probe S/N 00153632.

I would like to take this opportunity to express our appreciation for using ETS-Lindgren for your EMI test equipment services and I am looking forward to continued business with your organization. Please feel free to contact our offices at (512) 531-6400, if you have any questions regarding this report.

Sincerely,

George Cisneros
Calibration Supervisor

Date Attested: 16-May-16



Cert I.D.: 114197

Certificate of Calibration Conformance

Page 1 of 3

The instrument identified below has been individually calibrated in compliance with the following standard(s):
 IEEE 1309 - 2013, Institute of Electrical and Electronics Engineers, Standard for Calibration of Electromagnetic Field Sensors and Probes, Excluding Antennas from 9 kHz to 40 GHz.

Environment: Laboratory MTE is maintained in a temperature controlled environment with ambient conditions from 18 to 28 C, relative humidity less than 90%. The instrument under test has been calibrated in a suitable environment using an EMCO TEM Cell 5101C, GTEM1 5305 and an RF Shielded EMC Chamber which is conducive to maintaining accurate and reliable measurement quality.

Manufacturer:	ETS-Lindgren	Operating Range:	100kHz - 5GHz
Model Number:	E100	Instrument Type:	Isotropic Probe > 1 GHz
Serial Number/ ID:	00153632	Date Code:	
Tracking Number:	S 000035042	Alternate ID:	
Date Completed:	16-May-16	Customer:	Keysight Cal Lab C/O Motorola Solutions - 8000 West Sunrise Blvd. Plantation, FL 33322
Test Type:	Standard Field, Field Strength		

Calibration Uncertainty: Std Field Method 100kHz - 6 GHz, +/-0.7 dB, Isotropy +/- 0.85
 k=2, (95% Confidence Level)

Test Remarks: Probe received in tolerance thus before and after data are the same.

Calibration Traceability: All Measuring and Test Equipment (MTE) identified below are traceable to the SI units through the National Institute for Standards and Technology (NIST) or other recognized National Metrology Institute. Calibration Laboratory and Quality System controls are compliant with ISO/IEC 17025-2005 and ANSI/NCSL Z540-1-1994.

Standards and Equipment Used:

Make / Model / Name / S/N / Recall Date	Condition of Instrument Upon Receipt:
HP 8648C Signal Generator 3836U02236 25-Feb-17	In Tolerance to Internal Quality Standards
Marconi 2024 Signal Generator 112343/043 02-Feb-17	
Hewlett Packard E4422B Signal Generator US40050591 22-Jul-16	On Release:
Rohde & Schwarz SMB 100A Signal Generator 101558 17-Aug-16	In Tolerance to Internal Quality Standards
Keysight E9304A Power Sensor MY56100005 18-Mar-17	
Agilent E9304A Power Sensor MY41499013 01-Mar-17	
Agilent E9304A Power Sensor MY41499012 17-Jun-16	
Agilent E4419B Power Meter MY40510693 22-Jan-17	
Agilent E4419B Power Meter GB40202754 22-Oct-16	
Agilent U2004A USB Power Sensor MY50000280 08-Oct-16	
Rohde & Schwarz 857.8008.02 Power Meter NRVD 100451 17-Jul-16	
Hewlett Packard 83650L Synthesized Sweep Gen 3844A00422 21-Jan-17	
Rohde & Schwarz NRV-Z55 Thermal Power Sensor 100037 16-Jul-16	
Rohde & Schwarz NRV-Z55 Thermal Power Sensor 100362 14-Nov-16	
Rohde & Schwarz NRV-Z55 Thermal Power Sensor 100363 18-Aug-16	
Rohde & Schwarz NRP-Z91 Power Sensor 100733 16-Jul-16	
Rohde & Schwarz NRP-Z91 Power Sensor 100732 16-Jul-16	

Francisco D Maldonado
 Calibration Completed By
 Francisco D Maldonado, Calibration Technician

George Cisneros
 Attested and Issued on 16-May-16
 George Cisneros, Calibration Supervisor

This document provides traceability of measurements to recognized national standards using controlled processes at the ETS-Lindgren Calibration Laboratory. Uncertainties listed are derived from the methods described by NIST Tech Note 1297. This certificate and report may not be reproduced, except in full, without the written approval of ETS-Lindgren Calibration Laboratory in accordance with ISO/IEC 17025-2005 and ANSI/NCSL Z540-1-1994. The results in this document relate only to the item(s) listed and should not be considered representative of a population unless otherwise noted. DAF 1127 (09/11)

CALIBRATION REPORT

Electric Field Sensor

<i>Model</i>	<i>S/N</i>
E100	00153632
HI-2200	00086316

Date: 16 May 2016

- New Instrument
- Other
- Out of Tolerance
- Within Tolerance

Frequency Response

<i>Frequency Response</i>	<i>MHz</i>	<i>Nominal Field</i>	<i>Cal Factor*</i>	<i>Deviation</i>
		<i>V/m</i>	<i>(Applied/Indicated)</i>	<i>dB</i>
1	0.1	20	1.30	-2.26
2	0.5	20	1.08	-0.64
3	1	20	1.08	-0.64
4	3	20	1.01	-0.12
5	15	20	1.00	-0.02
6	27.12	20	1.00	-0.04
7	100	20	1.02	-0.15
8	200	20	1.00	0.03
9	1	20	1.08	-0.64
10	15	20	1.00	-0.02
11	30	20	1.00	-0.04
12	75	20	1.01	-0.11
13	100	20	1.02	-0.15
14	150	20	1.01	-0.06
15	200	20	1.00	0.03
16	250	20	0.99	0.12
17	300	20	0.99	0.10
18	400	20	0.99	0.08
19	500	20	1.03	-0.25
20	600	20	1.04	-0.36
21	700	20	1.07	-0.55
22	800	20	1.08	-0.69
23	900	20	1.03	-0.24
24	1000	20	0.99	0.13
25	2000	20	1.05	-0.40
26	2450	20	1.08	-0.69
27	3000	20	1.06	-0.54
28	3500	20	1.01	-0.12
29	4000	20	1.03	-0.24
30	5000	20	1.32	-2.41
31	5500	20	1.45	-3.25
32	6000	20	1.41	-3.00

* Corrected electric field values (V/m) can be obtained by multiplying the Cal Factor with the indicated E field readings.

Linearity

maximum linearity deviation is 0.34 dB
 (measurements taken from 0.3 V/m to 800 V/m at 27.12 MHz)

Test Conditions

Calibration performed at ambient room temperature: 23 ±0.3°C



PROBE ROTATIONAL RESPONSE

Model E100
S/N 00153632
Report S000035042
Date Date of Calibration 16 May 2016
Time 01:40:27 PM
Isotropy * + 0.270 dB/ -0.270 dB

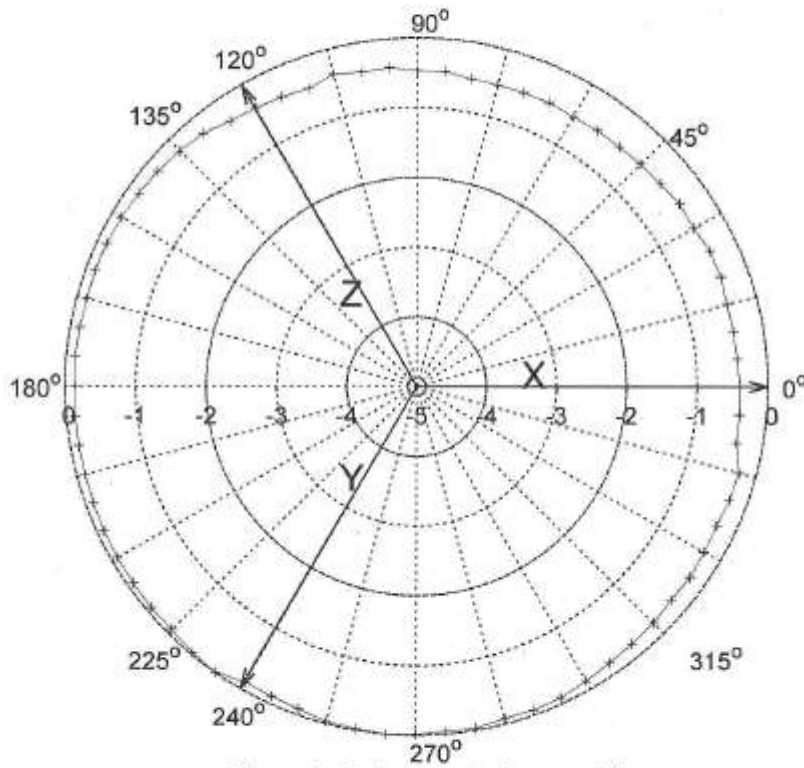

Figure 1: Probe Isotropic Response Chart.

Isotropic response is measured in a 20 V/m field at 400 MHz

*Isotropy is the maximum deviation from the geometric mean as defined by IEEE 1309-2013.



An ESCO Technologies Company
 1301 Arrow Point Drive
 Cedar Park, Texas 78613
 (512) 531-6400



Cert I.D.: 114199

Certificate of Calibration Conformance

Page 1 of 2

The instrument identified below has been individually calibrated in compliance with the following standard(s):
 IEEE 1309 - 2013, Institute of Electrical and Electronics Engineers, Standard for Calibration of Electromagnetic Field Sensors and Probes, Excluding Antennas from 9 kHz to 40 GHz

Environment: Laboratory MTE is maintained in a temperature controlled environment with ambient conditions from 18 to 28 C, relative humidity less than 90%. The instrument under test has been calibrated in a suitable environment using an EMCO TEM Cell 5101C, GTEM! 5305 and an RF Shielded EMC Chamber which is conducive to maintaining accurate and reliable measurement quality.

Manufacturer:	ETS-Lindgren	Operating Range:	6-300MHz / 30mA/m-10A/m
Model Number:	H200	Instrument Type:	Isotropic Magnetic Field Probe (2)
Serial Number / ID:	00206937		
Date Completed:	16-May-16		
Test Type:	Standard Field, Field Strength		
Calibration Uncertainty:	Direct Field Method	1.15dB	

k=2, (95% Confidence Level)

Test Remarks:

Calibration Traceability: All Measuring and Test Equipment (MTE) identified below are traceable to the SI units through the National Institute for Standards and Technology (NIST) or other recognized National Metrology Institute. Calibration Laboratory and Quality System controls are compliant with ISO/IEC 17025-2005 and ANSI/NCSL Z540-1-1994.

Standards and Equipment Used: Make / Model / Name / S/N / Recall Date					Condition of Instrument On Release:
HP	8648C	Signal Generator	3836U02236	25-Feb-17	In Tolerance to Internal Quality Standards
Marconi	2024	Signal Generator	112343/043	02-Feb-17	
Hewlett Packard	E4422B	Signal Generator	US40050591	22-Jul-16	
Rohde & Schwarz	SMB 100A	Signal Generator	101558	17-Aug-16	
Keysight	E9304A	Power Sensor	MY56100005	18-Mar-17	
Agilent	E9304A	Power Sensor	MY41499013	01-Mar-17	
Agilent	E9304A	Power Sensor	MY41499012	17-Jun-16	
Agilent	E4419B	Power Meter	MY40510693	22-Jan-17	
Agilent	E4419B	Power Meter	GB40202754	22-Oct-16	
Agilent	U2004A	USB Power Sensor	MY50000280	08-Oct-16	

Calibration Completed By
 Francisco D Maldonado, Calibration Technician

Attested and Issued on 16-May-16
 George Cisneros, Calibration Supervisor

This document provides traceability of measurements to recognized national standards using controlled processes of the ETS-Lindgren Calibration Laboratory. Uncertainties listed are derived from the methods described by NIST Tech Note 1297. This certificate and report may not be reproduced, except in full, without the written approval of ETS-Lindgren Calibration Laboratory in accordance with ISO/IEC 17025-2005 and ANSI/NCSL Z540-1-1994. The results in this document relate only to the item(s) listed and should not be considered representative of a population unless otherwise noted. QAF 1127 (03/11)

CALIBRATION REPORT

Magnetic Field Sensor

<i>Model</i>	<i>S/N</i>
H200	00206937
HI-2200	00086316

Date: 16 May 2016

- New Instrument
- Other
- Out of Tolerance
- Within Tolerance

Frequency Response

<i>Frequency Response</i>	<i>MHz</i>	<i>Nominal Field</i> <i>A/m</i>	<i>Cal Factor*</i> <i>(Applied/Indicated)</i>	<i>Deviation</i> <i>dB</i>
1	10	30	1.07	-0.58
2	15	30	1.05	-0.42
3	30	30	1.01	-0.09
4	50	30	0.99	0.05
5	75	30	0.96	0.33
6	100	30	0.90	0.94
7	150	30	0.87	1.18
8	175	30	0.84	1.53
9	200	30	0.80	1.94
10	250	30	0.70	3.12
11	300	30	0.56	5.09

* Corrected magnetic field values (A/m) can be obtained by multiplying the Cal Factor with the indicated H field readings.

Linearity

maximum linearity deviation is 0.06 dB
(measurements taken from 30 mA/m to 8 A/m at 27.12 MHz)

Test Conditions

Calibration performed at ambient room temperature: 23 ±3°C
The above sensor was calibrated to factory specifications. This calibration is performed per IEEE 1309 standard. All equipment used are traceable to US National Institute of Standards and Technology (NIST).

Appendix C - Photos of Assessed Antennas
(All antennas mounted to the vehicle with magnetic mount base)

APX 6500 8/900MHz

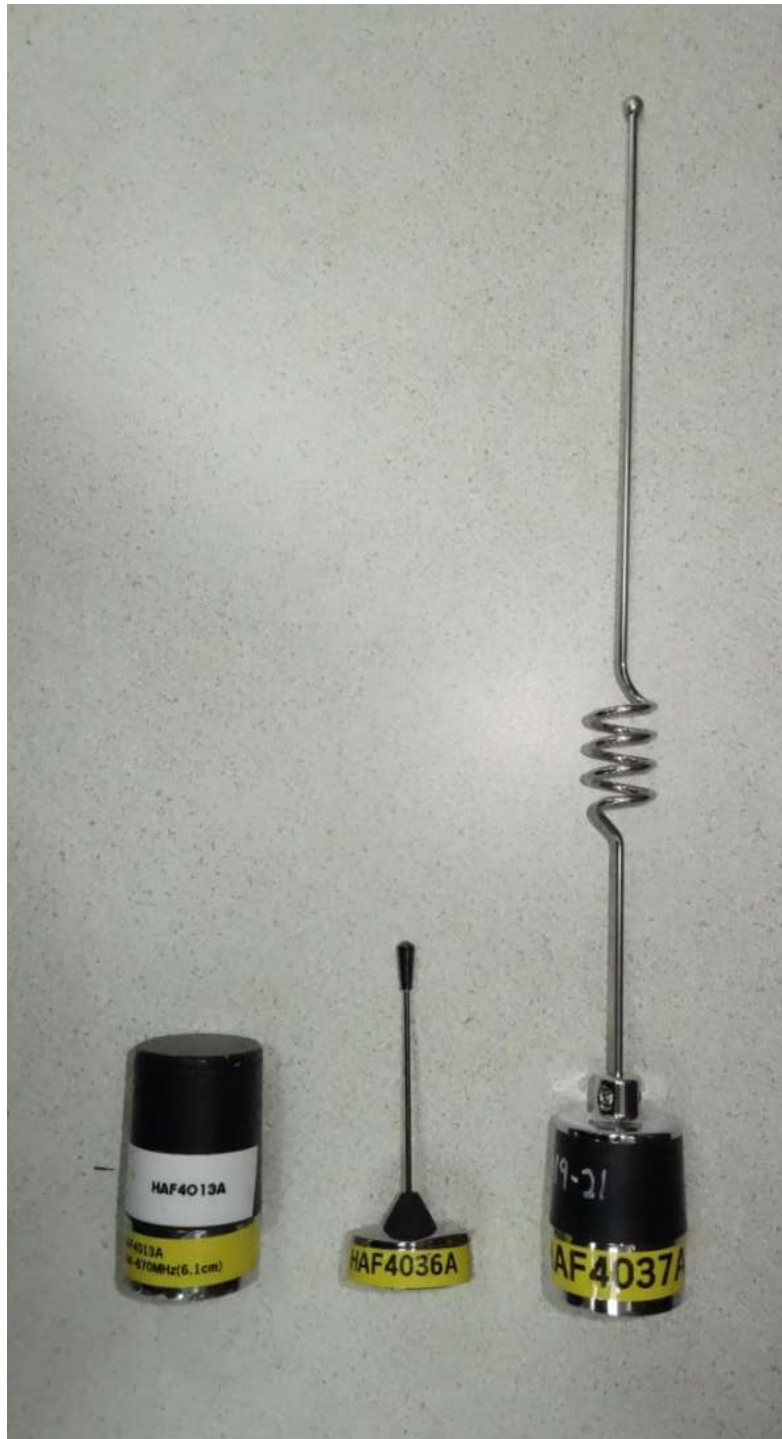

Antenna kit numbers: (From Left to Right)
HAF4013A, HAF4036A, HAF4037A

Companion Device (DVR 700)



Antenna kit number
HAF4016A