



DECLARATION OF COMPLIANCE: MPE ASSESSMENT

<p>Motorola Solutions Inc. EME Test Laboratory Motorola Solutions Malaysia Sdn Bhd Plot 2A, Medan Bayan Lepas, Mukim 12 SWD 11900 Bayan Lepas Penang, Malaysia.</p>	<p>Date of Report: 3/5/2021 Report Revision: B</p>
--	--

Responsible Engineer: Goh Jue Yie (EME Engineer)
Report author: Goh Jue Yie (EME Engineer)
Date(s) Tested: 12/4/2020,12/6/2020,12/7/2020,12/8/2020,12/9/2020,12/10/2020,12/11/2020, 12/22/2020, 1/18/2021
Manufacturer: Motorola Solutions Inc.
Date submitted for test: 11/26/2020
DUT Description: XPR 5550e 403-470M 40W GOB BT/GNSS/WiFi CD / XPR 5350e 403-470M 40W GOB BT/GNSS/WIFI ND
Test TX mode(s): CW
Max. Power output: 48W (403-470 MHz); 3.16mW (Bluetooth); 3.98mW (Bluetooth LE); 17.8 mW (WLAN 2.4GHz 802.11b), 13.2mW (WLAN 2.4GHz 802.11g), 8.3mW (WLAN 2.4GHz 802.11n)
TX Frequency Bands: 403-470 MHz; WLAN 2412-2462 MHz; BT 2402-2480 MHz
Signaling type: FM, TDMA, FHSS (Bluetooth), 802.11b/g/n (WLAN 2.4 GHz)
Model(s) Tested: AAM28QPN9RA1AN (PMUE3649C) (IC MODEL: PMUE3649CBMNAA)
Model(s) Certified: AAM28QPN9RA1AN (PMUE3649C) (IC MODEL: PMUE3649CBMNAA), AAM28QPC9RA1AN (PMUE3649C) (IC MODEL: PMUE3649CBLNAA) and AAM28QPN9WA1AN (PMUE3649C) (IC MODEL: PMUE3649CBMNKA)
Serial Number(s): 511TWX2288
Classification: Occupational/Controlled Environment
Applicant Name: Motorola Solutions Inc.
Applicant Address: 8000 West Sunrise Boulevard, Fort Lauderdale, Florida 33322
FCC ID: AZ492FT7140
 406.1-470 MHz, 2402-2480 MHz, 2412-2462 MHz
 This report contains results that are immaterial for FCC equipment approval, which are clearly identified.
IC: 109U-92FT7140
 This report contains results that are immaterial for ISED Canada equipment approval, which are clearly identified.
FCC Test Firm Registration Number: 823256
ISED Test Site registration: 24843

The MPE results clearly demonstrate compliance with FCC Occupational/Controlled RF Exposure limits. FCC rules require compliance for Passengers and Bystanders to the FCC General Population/Uncontrolled limits. The test results clearly demonstrate compliance with ICNIRP Guidelines for limiting exposure in time-varying electric, magnetic, and electromagnetic fields (up to 300 GHz).

Based on the information and the testing results provided herein, the undersigned certifies that when used as stated in the operating instructions supplied, said product complies with the national and international reference standards and guidelines listed in section 4.0 of this report (no deviation from standard methods). This report shall not be reproduced without written approval from an officially designated representative of the Motorola Solutions Inc. EME Laboratory.
 I attest to the accuracy of the data and assume full responsibility for the completeness of these measurements.
 This reporting format is consistent with the suggested guidelines of the TIA TSB-159 April 2006
 The results and statements contained in this report pertain only to the device(s) evaluated herein.

<p>Saw Sun Hock (Approved Signatory) Approval Date: 3/5/2021</p>	
---	---

Document Revision History

Date	Revision	Comments
1/19/2021	A	Initial release
3/5/2021	B	Update the MPE Summary and WiFi/BT MPE Calculation Result

Table of Contents

1.0 Introduction..... 4

2.0 FCC MPE Summary 4

3.0 Abbreviations / Definitions..... 4

4.0 Referenced Standards and Guidelines..... 5

5.0 Power Density Limits..... 5

6.0 N_c Test Channels..... 7

7.0 Measurement Equipment 7

8.0 Measurement System Uncertainty Levels..... 7

9.0 Product and System Description 8

10.0 Additional Options and Accessories 9

11.0 Test Set-Up Description..... 9

12.0 Method of Measurement with trunk mounted antenna(s)..... 10

 12.1 External/Bystander vehicle MPE measurements..... 10

 12.2 Internal/Passenger vehicle MPE measurements 11

13.0 Method of Measurement with roof mounted antenna(s)..... 12

 13.1 External/Bystander vehicle MPE measurements..... 12

 13.2 Internal/Passenger vehicle MPE measurements 12

14.0 MPE Variability Requirement for External/Bystander vehicle MPE measurement 13

15.0 MPE Calculations 13

16.0 Antenna Summary..... 14

17.0 Test Results Summary 15

 17.1 MPE Test Results Summary for LMR 15

17.2 Assessment of Bluetooth / WLAN Radio and Simultaneous Transmission..... 30

 17.3 Simultaneous Transmission..... 32

18.0 Conclusion 33

19.0 User Instructions Considerations 34

Appendix A - Antenna Locations, Test Distances, and Cable Losses 35

Appendix B - Probe Calibration Certificates 40

Appendix C - Photos of Assessed Antennas..... 46

Appendix D - MPE Measurement Results..... 47

1.0 Introduction

This report details the test setup, test equipment and test results of Maximum Permissible Exposure (MPE) performed at Motorola Solutions’ outside test site for product model AAM28QPN9RA1AN (PMUE3649C) (IC MODEL: PMUE3649CBMNA).

2.0 FCC MPE Summary

Table 1

Equipment Class	Frequency band (MHz)	Trunk Mounted Antennas				Roof Mounted Antennas			
		Passenger		Bystander		Passenger		Bystander	
		Power Density (mW/cm ²)	Percentage of Limit (%)	Power Density (mW/cm ²)	Percentage of Limit (%)	Power Density (mW/cm ²)	Percentage of Limit (%)	Power Density (mW/cm ²)	Percentage of Limit (%)
TNB	406.1-470 (LMR UHF)	0.259	92.5	0.149	49.7	0.065	24.2	0.088	31.5
DTS	2412 – 2462 (WLAN 2.4 GHz)	0.009	0.89	0.009	0.89	0.009	0.89	0.009	0.89
DSS	2402-2480 (Bluetooth)	0.002	0.15	0.002	0.15	0.002	0.15	0.002	0.15
Simultaneous (Highest Combined Percentage of Limit)		NA	93.39	NA	50.59	NA	25.09	NA	32.39

3.0 Abbreviations / Definitions

- BT: Bluetooth
- CNR: Calibration Not Required
- CW: Continuous Wave
- DUT: Device Under Test
- EME: Electromagnetic Energy
- FHSS: Frequency Hopping Spread Spectrum
- FM: Frequency Modulation
- MPE: Maximum Permissible Exposure
- GPS: Global Positioning System
- LMR: Land Mobile Radio
- NA: Not Applicable
- BS: Bystander
- PB: Passenger Back seat
- PF: Passenger Front seat
- PTT: Push to Talk
- WLAN: Wireless Local Area Network
- TDMA: Time Division Multiple Access

4.0 Referenced Standards and Guidelines

This product is designed to comply with the following applicable national and international standards and guidelines.

- United States Federal Communications Commission, Code of Federal Regulations; Rule Part 47CFR § 1.1310, § 2.1091 (d) and § 2.1093 for RF Exposure, where applicable.
- Federal Communications Commission, “Evaluating Compliance with FCC Guidelines for Human Exposure to Radio frequency Electromagnetic Fields”, OET Bulletin 65 (Edition 97-01), FCC, Washington, D.C.: August 1997.
- Institute of Electrical and Electronics Engineers (IEEE) C95. 1-2019
- American National Standards Institute (ANSI) / Institute of Electrical and Electronics Engineers (IEEE) C95. 1-1992. Specific to FCC rules and regulations.
- Institute of Electrical and Electronics Engineers (IEEE) C95.3-2002
- International Commission on Non-Ionizing Radiation Protection (ICNIRP) 1998
- Ministry of Health (Canada) Safety Code 6 (2015), Limits of Human Exposure to Radio frequency Electromagnetic Fields in the Frequency Range from 3 kHz to 300 GHz
- RSS-102 (Issue 5) – Radio Frequency (RF) Exposure Compliance of Radio communication Apparatus (All Frequency Bands)
- FCC KDB – 447498 D01 General RF Exposure Guidance v06
- FCC KDB – 865664 D02 RF Exposure Reporting v01r02
- EN 62311:2008 Assessment of electronic and electrical equipment related to human exposure restrictions for electromagnetic fields (0 Hz – 300 GHz).

5.0 Power Density Limits

Table 2 – Occupational / Controlled Exposure Limits

Frequency Range (MHz)	FCC OET Bulletin 65/ 47CFR § 1.1310	ICNIRP	IEEE C95.1 2019	RSS-102 Issue 5 2015
	mW/cm ²			W/m ²
10 – 20				10.0
20 – 48				$44.72 / f^{0.5}$
30 – 300	1.0			
48 – 100				6.455
10 – 400		10.0		
100 – 400			10.0	
100 – 6,000				$0.6455 f^{0.5}$
300 – 1,500	f/300			

Table 2 – Occupational / Controlled Exposure Limits (Con't.)

Frequency Range (MHz)	FCC OET Bulletin 65/ 47CFR § 1.1310	ICNIRP	IEEE C95.1 2019	RSS-102 Issue 5 2015
	mW/cm ²			
400 – 2,000		f/40	f/40	
1,500 – 100,000	5.0			
2,000 – 300,000		50.0	50.0	
6,000 – 15,000				50.0
15000 – 150,000				50.0
150000 – 300,000				$3.33 \times 10^{-4} f$

Table 3 – General Population / Uncontrolled Exposure Limits

Frequency Range (MHz)	FCC OET Bulletin 65/ 47CFR § 1.1310	ICNIRP	IEEE C95.1 2019	RSS-102 Issue 5 2015
	mW/cm ²			
10 – 20				2.0
20 – 48				$8.944 / f^{0.5}$
30 – 300	0.2			
48 – 300				1.291
10 – 400		2.0		
100 – 300				
100 – 400			2.0	
300 – 1,500	f/1,500			
300 – 6000				$0.02619 f^{0.6834}$
400 – 2,000		f/200	f/200	
1,500 – 100,000	1.0			
2,000 – 300,000		10.0	10.0	
6,000 – 15,000				10.0
15,000 – 150,000				10.0
150,000 – 300,000				$6.67 \times 10^{-5} f$

6.0 N_c Test Channels

The number of test channels is determined by using Equation 1 below. This equation is available in FCC’s KDB 447498. The test channels are appropriately spaced across the antenna’s frequency range.

Equation 1 – Number of test channels

$$N_c = \text{Round} \{ [100(f_{\text{high}} - f_{\text{low}})/f_c]^{0.5} \times (f_c / 100)^{0.2} \}$$

where N_c is the number of test channels, f_{high} and f_{low} are the highest and lowest frequencies within the transmission band, f_c is the mid-band frequency, and frequencies are in MHz.

7.0 Measurement Equipment

Table 4 – Equipment

Equipment Type	Model #	SN	Calibration Date	Calibration Due Date
Automobile	Volvo 240-1988	NA	NA	NA
Survey Meter	ETS Model HI-2200	00206805	04/01/2019	04/01/2020
Probe – E-Field	ETS Model E100	00126277		

E-field measurements are in mW/cm².

8.0 Measurement System Uncertainty Levels

Table 5 – Uncertainty Budget for Near Field Probe Measurements

	Tol. (± %)	Prob. Dist.	Divisor	u_i (±%)		v_i
Measurement System						
Probe Calibration	7.1	N	1.00	7.1	50.4	∞
Survey Meter Calibration	0.0	N	1.00	0.0	0.0	¥
Hemispherical Isotropy	8.0	R	1.73	4.6	21.33	∞
Linearity	5.0	R	1.73	2.9	8.33	∞
Pulse Response	1.0	R	1.73	0.6	0.33	∞
RF Ambient Noise	3.0	R	1.73	1.7	3.00	∞
RF Reflections	8.0	R	1.73	4.6	21.33	∞
Probe Positioning	10.0	R	1.73	5.8	33.333	∞
Test sample Related					0.00	
Antenna Positioning	3.0	N	1.00	3.0	9.0	∞
Power drift	5.0	R	1.73	2.9	8.33	∞
Bystander measurement uncertainty	4.8	N	1.00	4.8	23.04	∞
Passenger measurement uncertainty	8.1	N	1.00	8.1	65.61	∞
Combined Standard Uncertainty		RSS		15.6	15.6	∞
Expanded Uncertainty (95% CONFIDENCE LEVEL)		$k=2$		31	31	

9.0 Product and System Description

This mobile device operates in the LMR bands using either frequency modulation (FM) with 100% transmit duty cycle or TDMA signals with maximum of 50% transmit duty cycle. For conservative assessment, FM signal was tested. A duty factor of 50% applies for PTT operation mode.

This device also incorporates a Class 1 Bluetooth device which is a Frequency Hopping Spread Spectrum (FHSS) technology. The Bluetooth radio modem is used to wireless link audio accessories. The maximum actual transmission duty cycle is imposed by the Bluetooth standard. The maximum duty cycle for BT is 77%. Bluetooth Low Energy (BT LE) intended to reduce power consumption.

This device also contains WLAN technology for data capabilities over 802.11b/g/n 2.4 GHz wireless networks.

Table 6 below summarizes the technologies, bands, maximum duty cycles and maximum output powers. Maximum output powers are defined as upper limit of the production line final test station.

Table 6

Technologies	Bands (MHz)	Duty Cycle (%)	Max Power (W)
LMR	403-470 (UHF)	50 (PTT)	48
BT	2402-2480	77	0.00316
BT LE	2402-2480	77	0.00398
WLAN	2412 – 2484 (802.11b/g/n)	99.8	0.0178 (802.11b)
		99.2	0.0132 (802.11g)
		99.1	0.0083 (802.11n)

This device will be marketed to and used by employees solely for work-related operations, such as public safety agencies, e.g. police, fire and emergency medical. User training is the responsibility of these agencies which can be expected to employ the usage instructions, safety information and operational cautions set forth in the user's manual, instructional sessions or other means.

Accordingly this product is classified as Occupational/Controlled Exposure. However, in accordance with FCC requirements, the passengers inside the vehicle and the bystanders external to the vehicle are evaluated to the General Population/Uncontrolled Exposure Limits.

(Note that “Bystanders” as used herein are people other than operator)

10.0 Additional Options and Accessories

Below are additional antenna kits which include the tested antennas and GPS base.

HAE6019A – Identical to tested antenna HAE6029A with GPS base
PMAE4030A - Identical to tested antenna PMAE4039A with GPS base
PMAE4031A - Identical to tested antenna PMAE4041A with GPS base
PMAE4032A – Identical to tested antenna PMAE4040A with GPS base
PMAE4033A – Identical to tested antenna PMAE4042A with GPS base
PMAE4034A – Identical to tested antenna PMAE4043A with GPS base

Below are additional antenna kits that are electrically identical to the tested antennas but have a BNC connector instead of the mini-U connector (tested) and / or a GPS base:

RAE4151A -Identical to tested antenna PMAE4039A with BNC connector
RAE4152A - Identical to tested antenna PMAE4041A with BNC connector
RAE4154A - Identical to tested antenna PMAE4043A with BNC connector
RAE4158A - Identical to tested antenna PMAE4010A with BNC connector
HAE6017A - Identical to tested antenna HAE6029A with GPS base and BNC connector
HAE6021A - Identical to tested antenna HAE6029A with BNC connector
PMAE4035A - Identical to tested antenna PMAE4039A with GPS base and BNC connector
PMAE4036A- Identical to tested antenna PMAE4040A with GPS base and BNC connector
PMAE4037A- Identical to tested antenna PMAE4041A with GPS base and BNC connector
PMAE4038A- Identical to tested antenna PMAE4043A with GPS base and BNC connector

11.0 Test Set-Up Description

Assessments were performed with mobile radio installed in the test vehicle, at the specified distances and test locations indicated in sections 12.0, 13.0 and Appendix A.

All antennas described in Table 7 were considered in order to develop the test plan for this product. Antennas were installed and tested per their appropriate mount locations (Roof / Trunk) and defined test channels.

The system was tested using a low-loss 16' Teflon RG58A/U cable attaching the radio to the transmit antenna. This cable is shorter and lower attenuation than the 17' RG58A/U cables supplied in the customer kits for connecting the radio to the transmit antenna. The cable used in the test setup also has lower attenuation over the test frequency range than the cable provided in the customer kits. The use of a shorter cable with lower attenuation in the test setup ensures that the test data is more conservative with regards to the actual installation. Cable losses are reported in Appendix A.

12.0 Method of Measurement with trunk mounted antenna(s)

12.1 External/Bystander vehicle MPE measurements

Initially the antenna is located at the center of the trunk. Refer to Appendix A for antenna location and distance.

MPE measurements for bystander (BS) conditions are determined by taking the average of (10) measurements in a 2 m vertical line for each of the (3) bystander test locations indicated in Appendix A with 20 cm height increments, with the distance between the antenna and the geometric center of the probe sensor equal to 90 cm (for VHF band). The measurement probe is positioned orthogonal to antenna (typically parallel to ground with a vertically mounted antenna) and aimed directly at the antenna's axis. These measurements are representative of persons other than the operator standing next to the vehicle.

Each of the offered antennas mounted at the center of the trunk were assessed at the rear of the vehicle while maintaining a minimum of twenty (20) centimeter separation distance between the probe sensor and vehicle body. The worst case antenna was then tested at a 45° radial at the corner of the trunk, and 90° radial at the side of the trunk.

Tests for the 90° radial direction were conducted with the antenna displaced towards the "bystander on the side of the trunk" test location in order to attain 90 cm (12 cm antenna displacement) distances from that test location. In this way, the antenna is closer to the test location, and the MPE is higher, than it would be if the antenna was left at the center of the trunk

12.2 Internal/Passenger vehicle MPE measurements

Antenna is located toward the center of the trunk at a minimum 85 cm from backseat passenger. Users are instructed, per installation manual, to mount antennas on the roof only if a minimum 85cm cannot be achieved. Refer to Appendix A for antenna location and distance.

MPE measurements for passenger front seat (PF) and backseat (PB) conditions are determined by taking the average of the (3) measurements (Head, Chest, and Lower Trunk) inside the vehicle for both the front and back seats.

The backseat is a bench seat and therefore each position (Head, Chest & Lower Trunk) were scanned across (horizontally) the seat starting from the middle of the seat to the edge of the seat stopping 20 cm from the vehicle door. Similar process was used in the front bucket seat.

The probe handle is oriented parallel (horizontal) to the ground and pointed towards the back of the vehicle. The probe handle is not oriented normal to the seat surface. The probe head (incorporating the field sensors) is scanned continuously (using the max-hold function available in the meter) along three test axes which are parallel to the seat angle (intended as the line determined by the intersection of the plane of the seat and the plane of the backrest) and are 20 cm from the seat surface. One test axis is at the Head height, another is at the Chest height, and another is at the Lower Trunk height. The maximum field level value recorded for each test axis is logged. The MPE is determined by averaging these three maximum values regardless of the geometrical location where they were observed. For instance, the locations of the three maxima may lie on different vertical (relative to ground) lines.

This approach leads to results that are representative of the exposure of vehicle occupants since it is based on an average across the body portions closest to the antenna for both trunk and roof mount positions, and is conservatively biased because the highest results for each test axis are combined, e.g. the highest head exposure could be in the middle of the seat while the highest lower trunk exposure could be closer to the door.

13.0 Method of Measurement with roof mounted antenna(s)

13.1 External/Bystander vehicle MPE measurements

Antenna is located at the center of the roof. Refer to Appendix A for antenna location and distance.

MPE measurements for bystander (BS) conditions are determined by taking the average of (10) measurements in a 2m vertical line for the test location indicated in Appendix A with 20 cm height increments, with the distance between the antenna and the geometric center of the probe sensor equal to 90 cm (for VHF band). The measurement probe is positioned orthogonal to antenna (typically parallel to ground with a vertically mounted antenna) and aimed directly at the antenna's axis. These measurements are representative of persons other than the operator standing next to the vehicle.

13.2 Internal/Passenger vehicle MPE measurements

Antenna is located at the center of the roof. Refer to Appendix A for antenna location and distance.

MPE measurements for passenger front seat (PF) and backseat (PB) conditions are determined by taking the average of the (3) measurements (Head, Chest, and Lower Trunk) inside the vehicle for both the front and back seats.

The backseat is a bench seat and therefore each position (Head, Chest & Lower Trunk) were scanned across (horizontally) the seat starting from the middle of the seat to the edge of the seat stopping 20 cm from the vehicle door. Similar process was used in the front bucket seat.

The probe handle is oriented parallel (horizontal) to the ground and pointed towards the back of the vehicle. The probe handle is not oriented normal to the seat surface. The probe head (incorporating the field sensors) is scanned continuously (using the max-hold function available in the meter) along three test axes which are parallel to the seat angle (intended as the line determined by the intersection of the plane of the seat and the plane of the backrest) and are 20 cm from the seat surface. One test axis is at the Head height, another is at the Chest height, and another is at the Lower Trunk height. The maximum field level value recorded for each test axis is logged. The MPE is determined by averaging these three maximum values regardless of the geometrical location where they were observed. For instance, the locations of the three maxima may lie on different vertical (relative to ground) lines.

This approach leads to results that are representative of the exposure of vehicle occupants since it is based on an average across the body portions closest to the antenna for both trunk and roof mount positions, and is conservatively biased because the highest results for each test axis are combined, e.g. the highest head exposure could be in the middle of the seat while the highest lower trunk exposure could be closer to the door.

14.0 MPE Variability Requirement for External/Bystander vehicle MPE measurement

If all the MPE bystander measurements for a particular antenna are below 50% of the FCC MPE limit, no variability testing for that antenna is required.

If one or more MPE bystander measurements for a particular is between 50-80% of the FCC MPE limit, with no results > 80%, variability testing shall be done on the single worst case for that antenna.

For any MPE bystander measurement above 80% of the MPE limit, variability testing shall be done for all of such configuration. When SAR simulation is performed for a particular antenna configuration to determine compliance, variability measurements are not required for that antenna configuration.

15.0 MPE Calculations

The final MPE results for this mobile radio are presented in section 16.0. These results are based on 50% duty cycle for PTT for LMR bands.

Below is an explanation of how the MPE results are calculated. Refer to Appendix D for MPE measurement results and calculations for LMR band.

External to vehicle (Bystander) - 10 measurements are averaged over the body (*Avg_over_body*).
Internal to vehicle (Passengers) - 3 measurements are averaged over the body (*Avg_over_body*).

The Average over Body test methodology is consistent with IEEE/ANSI C95.3-2002 guidelines.

Therefore;

Equation 2 – Power Density Calculation (*Calc. _P.D.*)

$$\text{Calc. _P.D.} = (\text{Avg_over_body}) * (\text{probe_frequency_cal_factor}) * (\text{duty_cycle})$$

Note 1: The highest “average” cal factors from the calibration certificates were selected for the applicable frequency range. Linear interpretation was used to determine “probe_frequency_cal_factor” for the specific test frequencies.

Note 2: The E-field probe calibration certificate’s frequency cal factors were determined by measuring V/m. The survey meter’s results were measured in power density (mW/cm²) and therefore the “probe_frequency_cal_factor” was squared in equation 2 to account for these results.

Note 3: The H-field probe calibration certificate’s frequency cal factors were determined by measuring A/m. The survey meter’s results were measured in A/m and therefore the “Avg_over_body” A/m results were converted to power density (mW/cm²) using the equation 3. H-field measurements are only applicable to frequencies below 300MHz.

Equation 3 – Converting A/m to mW/cm²

$$\text{mW/cm}^2 = (\text{A/m})^2 * 37.699$$

Equation 4 – Power Density Maximum Calculation

$$Max_Calc._P.D. = P.D._calc * \frac{max_output_power}{initial_output_power}$$

Note 4: For initial output power > max_output_power; max_output_power / initial output power = 1

16.0 Antenna Summary

Table below summarizes the tested or evaluated antennas and their descriptions, mount location (roof/trunk), overlap of FCC bands, number of test channels per FCC KDB 447498 (FCC N_c) and actual number of tested channels (Actual N_c). This information was used to determine the test configurations presented in this report.

Table 7

Antenna No.	Antenna Model	Frequency Range (MHz)	Physical Length (cm)	Gain (dBi)	Remarks	Mount Location (Roof/Trunk)	Overlap FCC Bands (MHz)	FCC N _c	Actual N _c
1	HAE4002A	403-430	17.7	2.15	1/4 WAVE	R	NA	3	4
2	HAE4003A	450-470	16.0	2.15	1/4 WAVE	R	450-470	3	3
3	HAE4010A	406-420	84.3	5.65	5/8 WAVE	R/T	406.1-420	3	3
4	HAE4011A	450-470	73.2	5.65	1/2 WAVE	R/T	450-470	3	3
5	HAE6022A	403-527	27.7	4.15	1/2 WAVE	R/T	406.1-470	5	6
6	HAE6029A	403-527	28.0	4.15	1/2 WAVE	R/T	406.1-470	5	6
7	PMAE4039A	403-430	14.9	2.15	1/4WAVE	R	NA	3	4
8	PMAE4040A	406-420	36.0	5.65	1/4WAVE	R/T	406.1-420	3	3
9	PMAE4041A	450-470	12.5	2.15	1/4 WAVE	R	450-470	3	3
10	PMAE4042A	450-470	31.0	5.65	5/8 WAVE	R/T	450-470	3	3
11	PMAE4043A	450-470	76.8	7.15	5/8 WAVE	R/T	450-470	3	3
12	RAE4004ARB*	445-470	95.5 (445.0125MHz) 93.9 (450.0125MHz) 91.5 (457.5MHz) 90.7 (460.0125MHz) 89 (469.9875MHz)	7.15	5/8 WAVE	R/T	445-470	5	5

Note:* Antenna length trimmed to frequency.

17.0 Test Results Summary

17.1 MPE Test Results Summary for LMR

Table 8

MPE assessment for LMR UHF - trunk mounted antenna – Bystander

Results in **BOLD** are configurations with highest percentage of limits

Trunk/ Roof	Test Position	E/H Field	Angle (Degree)	Antenna No.	Antenna Model	Max Pwr (W)	Initial Pwr (W)	Tx Freq (MHz)	Max Calc. P.D. (mW/cm ²)	FCC Limit	% To FCC Spec Limit	ICNIRP Limit	% To ICNIRP Spec Limit	ISED Limit	% To ISED Spec Limit
Trunk	BS	E	0	10	PMAE4042A, 5/8 Wave (450-470 MHz)	48.0	47.4	450.0125	0.14	0.30	44.9	0.23	59.8	0.17	79.0
							47.6	460.0125	0.13	0.31	43.0	0.23	57.3	0.17	76.3
							47.7	469.9875	0.13	0.31	40.1	0.23	53.4	0.18	71.6
				11	PMAE4043A, 5/8 Wave (450-470 MHz)	48.0	47.4	450.0125	0.15	0.30	49.7	0.23	66.2	0.17	87.5
							47.6	460.0125	0.14	0.31	44.7	0.23	59.6	0.17	79.3
							47.7	469.9875	0.11	0.31	35.8	0.23	47.8	0.18	64.0
							47.4	450.0125	0.15	0.30	49.7	0.23	66.2	0.17	87.5
							47.4	450.0125	0.15	0.30	49.7	0.23	66.2	0.17	87.5
				11	PMAE4043A, 5/8 Wave (450-470 MHz)	48.0	47.4	450.0125	0.12	0.30	40.8	0.23	54.4	0.17	71.8
				11	PMAE4043A, 5/8 Wave (450-470 MHz)	48.0	47.4	450.0125	0.11	0.30	37.2	0.23	49.6	0.17	65.5
				12	RAE4004ARB 5/8 Wave (445-470 MHz)	48.0	47.1	445.0125	0.11	0.30	36.2	0.22	48.3	0.17	63.5
							47.4	450.0125	0.11	0.30	37.2	0.23	49.6	0.17	65.5
							47.6	457.5000	0.12	0.31	40.5	0.23	54.0	0.17	71.7
							47.6	460.0125	0.11	0.31	35.9	0.23	47.9	0.17	63.7
							47.7	469.9875	0.10	0.31	32.8	0.23	43.8	0.18	58.6
				3	HAE4010A, 5/8 Wave (406-420 MHz)	48.0	46.6	406.1250	0.08	0.27	30.7	0.20	40.9	0.16	52.3
							47.2	413.0125	0.07	0.28	23.8	0.21	31.7	0.16	40.7
							46.8	419.9875	0.04	0.28	14.6	0.21	19.4	0.16	25.1

Table 8 (continued)

MPE assessment for LMR UHF - trunk mounted antenna – Bystander

Blue fonts: Frequencies not regulated by FCC.

Trunk/ Roof	Test Position	E/H Field	Angle (Degree)	Antenna No.	Antenna Model	Max Pwr (W)	Initial Pwr (W)	Tx Freq (MHz)	Max Calc. P.D. (mW/cm ²)	FCC Limit	% To FCC Spec Limit	ICNIRP Limit	% To ICNIRP Spec Limit	ISED Limit	% To ISED Spec Limit
Trunk	BS	E	0	4	HAE4011A, 1/2 Wave (450-470 MHz)	48.0	47.4	450.0125	0.11	0.30	37.0	0.23	49.3	0.17	65.1
							47.6	460.0125	0.07	0.31	24.1	0.23	32.1	0.17	42.7
							47.7	469.9875	0.04	0.31	13.0	0.23	17.3	0.18	23.2
				5	HAE6022A, 1/2 Wave (403-527 MHz)	48.0	46.7	403.0125	0.12	0.27	44.6	0.20	59.5	0.16	75.8
							46.6	406.1250	0.11	0.27	41.0	0.20	54.7	0.16	69.9
							46.8	419.9875	0.10	0.28	35.4	0.21	47.3	0.16	61.1
							47.0	436.5000	0.09	0.29	29.8	0.22	39.7	0.17	51.9
							47.5	453.0125	0.13	0.30	42.6	0.23	56.8	0.17	75.2
							47.7	469.9875	0.12	0.31	36.8	0.23	49.0	0.18	65.6
				6	HAE6029A, 1/2 Wave (403-527 MHz)	48.0	46.7	403.0125	0.12	0.27	44.1	0.20	58.8	0.16	75.0
							46.6	406.1250	0.12	0.27	42.5	0.20	56.6	0.16	72.4
							46.8	419.9875	0.10	0.28	35.8	0.21	47.8	0.16	61.7
							47.0	436.5000	0.08	0.29	28.1	0.22	37.5	0.17	49.1
							47.5	453.0125	0.12	0.30	40.1	0.23	53.5	0.17	70.8
							47.7	469.9875	0.12	0.31	36.6	0.23	48.9	0.18	65.4
				8	PMAE4040A, 1/4 Wave (406-420 MHz)	48.0	46.6	406.1250	0.09	0.27	34.5	0.20	46.0	0.16	58.8
							47.2	413.0125	0.10	0.28	35.2	0.21	46.9	0.16	60.3
							46.8	419.9875	0.09	0.28	33.3	0.21	44.4	0.16	57.3

Table 9

MPE assessment for LMR UHF - roof mounted antenna – Bystander

Blue fonts: Frequencies not regulated by FCC

Trunk/ Roof	Test Position	E/H Field	Antenna No.	Antenna Model	Max Pwr (W)	Initial Pwr (W)	Tx Freq (MHz)	Max Calc. F.D. (mW/cm ²)	FCC Limit	% To FCC Spec Limit	ICNIRP Limit	% To ICNIRP Spec Limit	ISED Limit	% To ISED Spec Limit
Roof	BS	E	1	HAE4002A, 1/4 Wave (403-430 MHz)	48.0	46.7	403.0125	0.08	0.27	28.5	0.20	38.0	0.16	48.4
						46.6	406.1250	0.07	0.27	27.1	0.20	36.2	0.16	46.3
						47.0	416.5000	0.08	0.28	29.0	0.21	38.6	0.16	49.8
						47.1	429.9875	0.08	0.29	28.2	0.21	37.6	0.17	48.9
			10	PMAE4042A, 5/8 Wave (450-470 MHz)	48.0	47.4	450.0125	0.07	0.30	22.8	0.23	30.4	0.17	40.1
						47.6	460.0125	0.09	0.31	27.7	0.23	37.0	0.17	49.2
						47.7	469.9875	0.09	0.31	27.3	0.23	36.4	0.18	48.7
			11	PMAE4043A, 5/8 Wave (450-470 MHz)	48.0	47.4	450.0125	0.08	0.30	26.5	0.23	35.3	0.17	46.7
						47.6	460.0125	0.09	0.31	28.5	0.23	38.0	0.17	50.5
						47.7	469.9875	0.08	0.31	24.0	0.23	32.0	0.18	42.9
			12	RAE4004ARB 5/8 Wave (445-470 MHz)	48.0	47.1	445.0125	0.05	0.30	17.3	0.22	23.1	0.17	30.4
						47.4	450.0125	0.06	0.30	20.1	0.23	26.7	0.17	35.3
						47.6	457.5000	0.07	0.31	23.5	0.23	31.3	0.17	41.6
						47.6	460.0125	0.07	0.31	21.6	0.23	28.8	0.17	38.3
						47.7	469.9875	0.06	0.31	18.9	0.23	25.2	0.18	33.8
			2	HAE4003A, 1/4 Wave (450-470 MHz)	48.0	47.4	450.0125	0.08	0.30	26.3	0.23	35.0	0.17	46.3
						47.6	460.0125	0.09	0.31	30.5	0.23	40.7	0.17	54.1
						47.7	469.9875	0.08	0.31	25.7	0.23	34.2	0.18	45.8

Table 9 (Continued)

MPE assessment for LMR UHF - roof mounted antenna – Bystander

Blue fonts: Frequencies not regulated by FCC.

Results in **BOLD** are configurations with highest percentage of limits

Trunk/ Roof	Test Position	E/H Field	Antenna No.	Antenna Model	Max Pwr (W)	Initial Pwr (W)	Tx Freq (MHz)	Max Calc. P.D. (mW/cm ²)	FCC Limit	% To FCC Spec Limit	ICNIRP Limit	% To ICNIRP Spec Limit	ISED Limit	% To ISED Spec Limit			
Roof	BS	E	3	HAE4010A, 5/8 Wave (406-420 MHz)	48.0	46.6	406.1250	0.04	0.27	16.2	0.20	21.6	0.16	27.7			
						47.2	413.0125	0.04	0.28	15.0	0.21	20.0	0.16	25.7			
						46.8	419.9875	0.03	0.28	9.5	0.21	12.6	0.16	16.3			
			4	HAE4011A, 1/2 Wave (450-470 MHz)	48.0	47.4	450.0125	0.07	0.30	21.8	0.23	29.1	0.17	38.4			
						47.6	460.0125	0.05	0.31	16.3	0.23	21.8	0.17	29.0			
						47.7	469.9875	0.03	0.31	9.7	0.23	12.9	0.18	17.3			
			5	HAE6022A, 1/2 Wave (403-527 MHz)	48.0	46.7	403.0125	0.09	0.27	32.1	0.20	42.8	0.16	54.6			
						46.6	406.1250	0.08	0.27	29.3	0.20	39.1	0.16	50.0			
						46.8	419.9875	0.09	0.28	31.5	0.21	42.0	0.16	54.3			
						47.0	436.5000	0.08	0.29	28.5	0.22	38.0	0.17	49.7			
						47.5	453.0125	0.08	0.30	26.5	0.23	35.3	0.17	46.7			
						47.7	469.9875	0.08	0.31	26.9	0.23	35.9	0.18	48.1			
			6	HAE6029A, 1/2 Wave (403-527 MHz)	48.0	46.7	403.0125	0.08	0.27	30.7	0.20	40.9	0.16	52.2			
						46.6	406.1250	0.08	0.27	28.5	0.20	38.0	0.16	48.5			
						46.8	419.9875	0.09	0.28	31.1	0.21	41.4	0.16	53.6			
						47.0	436.5000	0.08	0.29	28.7	0.22	38.2	0.17	50.0			
						47.5	453.0125	0.08	0.30	26.6	0.23	35.4	0.17	46.9			
						47.7	469.9875	0.09	0.31	27.2	0.23	36.3	0.18	48.6			

Table 9 (Continued)

MPE assessment for LMR UHF - roof mounted antenna – Bystander

Blue fonts: Frequencies not regulated by FCC.

Trunk/ Roof	Test Position	E/H Field	Antenna No.	Antenna Model	Max Pwr (W)	Initial Pwr (W)	Tx Freq (MHz)	Max Calc. P.D. (mW/cm ²)	FCC Limit	% To FCC Spec Limit	ICNIRP Limit	% To ICNIRP Spec Limit	ISED Limit	% To ISED Spec Limit
Roof	BS	E	7	PMAE4039A, 1/4 Wave (403-430 MHz)	48.0	46.7	403.0125	0.01	0.27	4.7	0.20	6.2	0.16	7.9
						46.6	406.1250	0.01	0.27	4.6	0.20	6.1	0.16	7.8
						47.0	416.5000	0.03	0.28	9.4	0.21	12.5	0.16	16.1
						47.1	429.9875	0.04	0.29	14.9	0.21	19.8	0.17	25.8
			8	PMAE4040A, 1/4 Wave (406-420 MHz)	48.0	46.6	406.1250	0.07	0.27	23.9	0.20	31.9	0.16	40.8
						47.2	413.0125	0.08	0.28	27.9	0.21	37.3	0.16	47.9
						46.8	419.9875	0.08	0.28	28.9	0.21	38.6	0.16	49.8
			9	PMAE4041A, 1/4 Wave (450-470 MHz)	48.0	47.4	450.0125	0.02	0.30	5.4	0.23	7.2	0.17	9.5
						47.6	460.0125	0.02	0.31	7.6	0.23	10.1	0.17	13.4
						47.7	469.9875	0.04	0.31	11.8	0.23	15.7	0.18	21.0

Table 10

MPE assessment for LMR UHF - trunk mounted antenna – Passenger Back

* Results required SAR simulation to demonstrate compliance to the basic requirements

Trunk/ Roof	Test Position	E/H Field	Antenna No.	Antenna Model	Max Pwr (W)	Initial Pwr (W)	Tx Freq (MHz)	Max Calc. P.D. (mW/cm ²)	FCC Limit	% To FCC Spec Limit	ICNIRP Limit	% To ICNIRP Spec Limit	ISED Limit	% To ISED Spec Limit
Trunk	PB	E	10	PMAE4042A, 5/8 Wave (450-470 MHz)	48.0	47.4	450.0125	0.22	0.30	72.0	0.23	96.0	0.17	*126.9
						47.6	460.0125	0.19	0.31	61.9	0.23	82.6	0.17	*109.8
						47.7	469.9875	0.21	0.31	67.5	0.23	90.0	0.18	*120.5
			11	PMAE4043A, 5/8 Wave (450-470 MHz)	48.0	47.4	450.0125	0.14	0.30	47.2	0.23	63.0	0.17	83.2
						47.6	460.0125	0.17	0.31	56.1	0.23	74.7	0.17	99.4
						47.7	469.9875	0.17	0.31	55.4	0.23	73.9	0.18	99.0
			12	RAE4004ARB 5/8 Wave (445-470 MHz)	48.0	47.1	445.0125	0.04	0.30	13.1	0.22	17.5	0.17	23.0
						47.4	450.0125	0.06	0.30	20.2	0.23	27.0	0.17	35.6
						47.6	457.5000	0.10	0.31	31.5	0.23	42.1	0.17	55.8
						47.6	460.0125	0.10	0.31	33.4	0.23	44.6	0.17	59.3
						47.7	469.9875	0.12	0.31	39.4	0.23	52.5	0.18	70.3
			3	HAE4010A, 5/8 Wave (406-420 MHz)	48.0	46.6	406.1250	0.07	0.27	27.3	0.20	36.4	0.16	46.5
						47.2	413.0125	0.05	0.28	16.4	0.21	21.9	0.16	28.1
						46.8	419.9875	0.03	0.28	11.3	0.21	15.1	0.16	19.5
			4	HAE4011A, 1/2 Wave (450-470 MHz)	48.0	47.4	450.0125	0.15	0.30	50.8	0.23	67.7	0.17	89.5
47.6	460.0125	0.12				0.31	37.5	0.23	50.0	0.17	66.6			
47.7	469.9875	0.07				0.31	23.8	0.23	31.7	0.18	42.4			

Table 10 (Continued)

MPE assessment for LMR UHF - trunk mounted antenna – Passenger Back

Blue fonts: Frequencies not regulated by FCC.

Results in **BOLD** are configurations with highest percentage of limits

* Results required SAR simulation to demonstrate compliance to the basic requirements

Trunk/ Roof	Test Position	E/H Field	Antenna No.	Antenna Model	Max Pwr (W)	Initial Pwr (W)	Tx Freq (MHz)	Max Calc. P.D. (mW/cm ²)	FCC Limit	% To FCC Spec Limit	ICNIRP Limit	% To ICNIRP Spec Limit	ISED Limit	% To ISED Spec Limit
Trunk	PB	E	5	HAE6022A, 1/2 Wave (403-527 MHz)	48.0	46.7	403.0125	0.17	0.27	62.6	0.20	83.5	0.16	*106.5
						46.6	406.1250	0.20	0.27	72.2	0.20	96.2	0.16	*123
						46.8	419.9875	0.21	0.28	74.9	0.21	99.9	0.16	*129.1
						47.0	436.5000	0.24	0.29	81.7	0.22	*108.9	0.17	*142.5
						47.5	453.0125	0.27	0.30	89.6	0.23	*119.5	0.17	*158.2
						47.7	469.9875	0.26	0.31	82.4	0.23	*109.8	0.18	*147.1
			6	HAE6029A, 1/2 Wave (403-527 MHz)	48.0	46.7	403.0125	0.17	0.27	62.4	0.20	83.2	0.16	*106.1
						46.6	406.1250	0.22	0.27	81.2	0.20	*108.2	0.16	*138.4
						46.8	419.9875	0.26	0.28	92.5	0.21	*123.3	0.16	*159.4
						47.0	436.5000	0.26	0.29	89.4	0.22	*119.1	0.17	*155.9
						47.5	453.0125	0.21	0.30	70.6	0.23	94.1	0.17	*124.6
						47.7	469.9875	0.27	0.31	84.6	0.23	*112.8	0.18	*151
			8	PMAE4040A, 1/4 Wave (406-420 MHz)	48.0	46.6	406.1250	0.22	0.27	81.1	0.20	*108.2	0.16	*138.3
						47.2	413.0125	0.22	0.28	78.5	0.21	*104.7	0.16	*134.5
						46.8	419.9875	0.26	0.28	91.6	0.21	*122.2	0.16	*157.9

Table 11

MPE assessment for LMR UHF - roof mounted antenna – Passenger Back

Blue fonts: Frequencies not regulated by FCC.

Results in **BOLD** are configurations with highest percentage of limits

Trunk/ Roof	Test Position	E/H Field	Antenna No.	Antenna Model	Max Pwr (W)	Initial Pwr (W)	Tx Freq (MHz)	Max Calc. P.D. (mW/cm ²)	FCC Limit	% To FCC Spec Limit	ICNIRP Limit	% To ICNIRP Spec Limit	ISED Limit	% To ISED Spec Limit
Roof	PB	E	1	HAE4002A, 1/4 Wave (403-430 MHz)	48.0	46.7	403.0125	0.05	0.27	17.0	0.20	22.7	0.16	29.0
						46.6	406.1250	0.04	0.27	15.9	0.20	21.2	0.16	27.2
						47.0	416.5000	0.03	0.28	12.1	0.21	16.2	0.16	20.8
						47.1	429.9875	0.04	0.29	13.9	0.21	18.6	0.17	24.2
			10	PMAE4042A, 5/8 Wave (450-470 MHz)	48.0	47.4	450.0125	0.05	0.30	15.9	0.23	21.1	0.17	27.9
						47.6	460.0125	0.05	0.31	16.3	0.23	21.7	0.17	28.9
						47.7	469.9875	0.04	0.31	13.5	0.23	18.0	0.18	24.2
			11	PMAE4043A, 5/8 Wave (450-470 MHz)	48.0	47.4	450.0125	0.02	0.30	7.0	0.23	9.4	0.17	12.4
						47.6	460.0125	0.02	0.31	5.6	0.23	7.5	0.17	10.0
						47.7	469.9875	0.02	0.31	5.1	0.23	6.9	0.18	9.2
			12	RAE4004ARB 5/8 Wave (445-470 MHz)	48.0	47.1	445.0125	0.01	0.30	1.8	0.22	2.3	0.17	3.1
						47.4	450.0125	0.01	0.30	2.1	0.23	2.8	0.17	3.7
						47.6	457.5000	0.01	0.31	3.2	0.23	4.3	0.17	5.7
						47.6	460.0125	0.01	0.31	2.7	0.23	3.6	0.17	4.8
						47.7	469.9875	0.01	0.31	2.4	0.23	3.2	0.18	4.2
			2	HAE4003A, 1/4 Wave (450-470 MHz)	48.0	47.4	450.0125	0.06	0.30	20.1	0.23	26.8	0.17	35.4
						47.6	460.0125	0.05	0.31	16.7	0.23	22.2	0.17	29.5
						47.7	469.9875	0.04	0.31	12.9	0.23	17.3	0.18	23.1

Table 11 (Continued)

MPE assessment for LMR UHF - roof mounted antenna – Passenger Back

Blue fonts: Frequencies not regulated by FCC.

Trunk/ Roof	Test Position	E/H Field	Antenna No.	Antenna Model	Max Pwr (W)	Initial Pwr (W)	Tx Freq (MHz)	Max Calc. P.D. (mW/cm ²)	FCC Limit	% To FCC Spec Limit	ICNIRP Limit	% To ICNIRP Spec Limit	ISED Limit	% To ISED Spec Limit			
Roof	PB	E	3	HAE4010A, 5/8 Wave (406-420 MHz)	48.0	46.6	406.1250	0.00	0.27	0.7	0.20	1.0	0.16	1.2			
						47.2	413.0125	0.00	0.28	1.0	0.21	1.3	0.16	1.6			
						46.8	419.9875	0.00	0.28	0.6	0.21	0.8	0.16	1.0			
			4	HAE4011A, 1/2 Wave (450-470 MHz)	48.0	47.4	450.0125	0.02	0.30	5.3	0.23	7.1	0.17	9.3			
						47.6	460.0125	0.01	0.31	2.1	0.23	2.7	0.17	3.6			
						47.7	469.9875	0.01	0.31	2.0	0.23	2.7	0.18	3.6			
			5	HAE6022A, 1/2 Wave (403-527 MHz)	48.0	46.7	403.0125	0.05	0.27	17.4	0.20	23.2	0.16	29.5			
						46.6	406.1250	0.04	0.27	15.0	0.20	19.9	0.16	25.5			
						46.8	419.9875	0.03	0.28	11.7	0.21	15.6	0.16	20.1			
						47.0	436.5000	0.04	0.29	12.5	0.22	16.6	0.17	21.7			
						47.5	453.0125	0.05	0.30	15.8	0.23	21.0	0.17	27.9			
						47.7	469.9875	0.03	0.31	10.5	0.23	14.0	0.18	18.8			
			6	HAE6029A, 1/2 Wave (403-527 MHz)	48.0	46.7	403.0125	0.03	0.27	12.6	0.20	16.7	0.16	21.3			
						46.6	406.1250	0.04	0.27	14.4	0.20	19.2	0.16	24.5			
						46.8	419.9875	0.03	0.28	9.6	0.21	12.8	0.16	16.5			
						47.0	436.5000	0.03	0.29	9.0	0.22	12.0	0.17	15.6			
						47.5	453.0125	0.05	0.30	15.1	0.23	20.2	0.17	26.7			
						47.7	469.9875	0.04	0.31	13.7	0.23	18.3	0.18	24.5			

Table 11 (Continued)

MPE assessment for LMR UHF - roof mounted antenna – Passenger Back

Blue fonts: Frequencies not regulated by FCC.

Trunk/ Roof	Test Position	E/H Field	Antenna No.	Antenna Model	Max Pwr (W)	Initial Pwr (W)	Tx Freq (MHz)	Max Calc. P.D. (mW/cm ²)	FCC Limit	% To FCC Spec Limit	ICNIRP Limit	% To ICNIRP Spec Limit	ISED Limit	% To ISED Spec Limit
Roof	PB	E	7	PMAE4039A, 1/4 Wave (403-430 MHz)	48.0	46.7	403.0125	0.01	0.27	2.5	0.20	3.4	0.16	4.3
						46.6	406.1250	0.01	0.27	1.7	0.20	2.3	0.16	2.9
						47.0	416.5000	0.01	0.28	3.2	0.21	4.2	0.16	5.4
						47.1	429.9875	0.01	0.29	4.1	0.21	5.5	0.17	7.2
			8	PMAE4040A, 1/4 Wave (406-420 MHz)	48.0	46.6	406.1250	0.04	0.27	13.0	0.20	17.3	0.16	22.2
						47.2	413.0125	0.04	0.28	12.7	0.21	16.9	0.16	21.7
						46.8	419.9875	0.02	0.28	8.2	0.21	10.9	0.16	14.1
			9	PMAE4041A, 1/4 Wave (450-470 MHz)	48.0	47.4	450.0125	0.00	0.30	1.4	0.23	1.8	0.17	2.4
						47.6	460.0125	0.01	0.31	2.1	0.23	2.8	0.17	3.7
						47.7	469.9875	0.01	0.31	1.9	0.23	2.5	0.18	3.4

Table 12
MPE assessment for LMR UHF - trunk mounted antenna – Passenger Front

Trunk/ Roof	Test Position	E/H Field	Antenna No.	Antenna Model	Max Pwr (W)	Initial Pwr (W)	Tx Freq (MHz)	Max Calc. P.D. (mW/cm ²)	FCC Limit	% To FCC Spec Limit	ICNIRP Limit	% To ICNIRP Spec Limit	ISED Limit	% To ISED Spec Limit
Trunk	PF	E	10	PMAE4042A, 5/8 Wave (450-470 MHz)	48.0	47.4	450.0125	0.14	0.30	46.3	0.23	61.7	0.17	81.5
						47.6	460.0125	0.10	0.31	33.4	0.23	44.5	0.17	59.2
						47.7	469.9875	0.10	0.31	32.9	0.23	43.9	0.18	58.7
			11	PMAE4043A, 5/8 Wave (450-470 MHz)	48.0	47.4	450.0125	0.11	0.30	36.6	0.23	48.7	0.17	64.4
						47.6	460.0125	0.09	0.31	28.7	0.23	38.2	0.17	50.9
						47.7	469.9875	0.09	0.31	29.4	0.23	39.2	0.18	52.4
			12	RAE4004ARB 5/8 Wave (445-470 MHz)	48.0	47.1	445.0125	0.02	0.30	7.3	0.22	9.8	0.17	12.9
						47.4	450.0125	0.04	0.30	12.9	0.23	17.2	0.17	22.7
						47.6	457.5000	0.05	0.31	14.7	0.23	19.6	0.17	26.0
						47.6	460.0125	0.04	0.31	12.8	0.23	17.0	0.17	22.7
						47.7	469.9875	0.03	0.31	9.3	0.23	12.4	0.18	16.6
			3	HAE4010A, 5/8 Wave (406-420 MHz)	48.0	46.6	406.1250	0.03	0.27	11.2	0.20	15.0	0.16	19.2
						47.2	413.0125	0.03	0.28	10.8	0.21	14.4	0.16	18.5
						46.8	419.9875	0.02	0.28	5.2	0.21	6.9	0.16	9.0
			4	HAE4011A, 1/2 Wave (450-470 MHz)	48.0	47.4	450.0125	0.07	0.30	21.6	0.23	28.8	0.17	38.0
						47.6	460.0125	0.06	0.31	17.9	0.23	23.8	0.17	31.7
						47.7	469.9875	0.04	0.31	11.6	0.23	15.5	0.18	20.7

Table 12 (Continued)

MPE assessment for LMR UHF - trunk mounted antenna – Passenger Front

Blue fonts: Frequencies not regulated by FCC.

Results in **BOLD** are configurations with highest percentage of limits

Trunk/ Roof	Test Position	E/H Field	Antenna No.	Antenna Model	Max Pwr (W)	Initial Pwr (W)	Tx Freq (MHz)	Max Calc. P.D. (mW/cm ²)	FCC Limit	% To FCC Spec Limit	ICNIRP Limit	% To ICNIRP Spec Limit	ISED Limit	% To ISED Spec Limit
Trunk	PF	E	5	HAE6022A, 1/2 Wave (403-527 MHz)	48.0	46.7	403.0125	0.08	0.27	28.7	0.20	38.2	0.16	48.8
						46.6	406.1250	0.07	0.27	26.7	0.20	35.6	0.16	45.5
						46.8	419.9875	0.07	0.28	25.7	0.21	34.2	0.16	44.2
						47.0	436.5000	0.09	0.29	31.4	0.22	41.8	0.17	54.7
						47.5	453.0125	0.15	0.30	50.8	0.23	67.7	0.17	89.6
						47.7	469.9875	0.11	0.31	33.4	0.23	44.6	0.18	59.7
			6	HAE6029A, 1/2 Wave (403-527 MHz)	48.0	46.7	403.0125	0.09	0.27	32.9	0.20	43.9	0.16	56.0
						46.6	406.1250	0.08	0.27	29.9	0.20	39.9	0.16	51.0
						46.8	419.9875	0.07	0.28	26.0	0.21	34.6	0.16	44.7
						47.0	436.5000	0.08	0.29	28.9	0.22	38.6	0.17	50.5
						47.5	453.0125	0.17	0.30	54.7	0.23	72.9	0.17	96.5
						47.7	469.9875	0.11	0.31	34.6	0.23	46.2	0.18	61.8
			8	PMAE4040A, 1/4 Wave (406-420 MHz)	48.0	46.6	406.1250	0.07	0.27	24.3	0.20	32.4	0.16	41.4
						47.2	413.0125	0.08	0.28	28.7	0.21	38.3	0.16	49.2
						46.8	419.9875	0.07	0.28	24.0	0.21	32.0	0.16	41.4

Table 13

MPE assessment for LMR UHF - roof mounted antenna – Passenger Front

Blue fonts: Frequencies not regulated by FCC.

Trunk/ Roof	Test Position	E/H Field	Antenna No.	Antenna Model	Max Pwr (W)	Initial Pwr (W)	Tx Freq (MHz)	Max Calc. P.D. (mW/cm ²)	FCC Limit	% To FCC Spec Limit	ICNIRP Limit	% To ICNIRP Spec Limit	ISED Limit	% To ISED Spec Limit
Roof	PF	E	1	HAE4002A, 1/4 Wave (403-430 MHz)	48.0	46.7	403.0125	0.05	0.27	17.1	0.20	22.8	0.16	29.1
						46.6	406.1250	0.05	0.27	19.5	0.20	26.0	0.16	33.3
						47.0	416.5000	0.05	0.28	16.9	0.21	22.6	0.16	29.1
						47.1	429.9875	0.04	0.29	13.8	0.21	18.4	0.17	24.0
			10	PMAE4042A, 5/8 Wave (450-470 MHz)	48.0	47.4	450.0125	0.03	0.30	9.7	0.23	12.9	0.17	17.0
						47.6	460.0125	0.03	0.31	10.5	0.23	14.0	0.17	18.6
						47.7	469.9875	0.03	0.31	10.5	0.23	14.0	0.18	18.7
			11	PMAE4043A, 5/8 Wave (450-470 MHz)	48.0	47.4	450.0125	0.01	0.30	4.2	0.23	5.6	0.17	7.5
						47.6	460.0125	0.01	0.31	3.8	0.23	5.1	0.17	6.8
						47.7	469.9875	0.01	0.31	4.0	0.23	5.4	0.18	7.2
			12	RAE4004ARB 5/8 Wave (445-470 MHz)	48.0	47.1	445.0125	0.00	0.30	0.6	0.22	0.8	0.17	1.1
						47.4	450.0125	0.00	0.30	0.9	0.23	1.2	0.17	1.6
						47.6	457.5000	0.01	0.31	2.3	0.23	3.1	0.17	4.1
						47.6	460.0125	0.01	0.31	1.8	0.23	2.4	0.17	3.2
						47.7	469.9875	0.01	0.31	2.1	0.23	2.8	0.18	3.7
			2	HAE4003A, 1/4 Wave (450-470 MHz)	48.0	47.4	450.0125	0.03	0.30	10.0	0.23	13.4	0.17	17.6
						47.6	460.0125	0.02	0.31	7.6	0.23	10.1	0.17	13.4
						47.7	469.9875	0.02	0.31	7.5	0.23	10.0	0.18	13.4

Table 13 (Continued)

MPE assessment for LMR UHF - roof mounted antenna – Passenger Front

Blue fonts: Frequencies not regulated by FCC.

Results in **BOLD** are configurations with highest percentage of limits

Trunk/ Roof	Test Position	E/H Field	Antenna No.	Antenna Model	Max Pwr (W)	Initial Pwr (W)	Tx Freq (MHz)	Max Calc. P.D. (mW/cm ²)	FCC Limit	% To FCC Spec Limit	ICNIRP Limit	% To ICNIRP Spec Limit	ISED Limit	% To ISED Spec Limit
Roof	PF	E	3	HAE4010A, 5/8 Wave (406-420 MHz)	48.0	46.6	406.1250	0.00	0.27	1.6	0.20	2.2	0.16	2.8
						47.2	413.0125	0.00	0.28	1.5	0.21	2.0	0.16	2.6
						46.8	419.9875	0.00	0.28	1.4	0.21	1.9	0.16	2.4
			4	HAE4011A, 1/2 Wave (450-470 MHz)	48.0	47.4	450.0125	0.01	0.30	3.0	0.23	4.1	0.17	5.4
						47.6	460.0125	0.01	0.31	2.4	0.23	3.2	0.17	4.3
						47.7	469.9875	0.01	0.31	2.3	0.23	3.0	0.18	4.0
			5	HAE6022A, 1/2 Wave (403-527 MHz)	48.0	46.7	403.0125	0.05	0.27	19.6	0.20	26.1	0.16	33.3
						46.6	406.1250	0.06	0.27	22.0	0.20	29.3	0.16	37.5
						46.8	419.9875	0.06	0.28	22.0	0.21	29.4	0.16	38.0
						47.0	436.5000	0.02	0.29	7.9	0.22	10.5	0.17	13.7
						47.5	453.0125	0.03	0.30	10.8	0.23	14.3	0.17	19.0
						47.7	469.9875	0.03	0.31	9.5	0.23	12.6	0.18	16.9
			6	HAE6029A, 1/2 Wave (403-527 MHz)	48.0	46.7	403.0125	0.05	0.27	19.7	0.20	26.3	0.16	33.5
						46.6	406.1250	0.07	0.27	24.2	0.20	32.2	0.16	41.2
						46.8	419.9875	0.06	0.28	21.5	0.21	28.7	0.16	37.1
						47.0	436.5000	0.02	0.29	8.1	0.22	10.8	0.17	14.1
						47.5	453.0125	0.03	0.30	11.0	0.23	14.7	0.17	19.4
						47.7	469.9875	0.04	0.31	11.2	0.23	14.9	0.18	19.9

Table 13 (Continued)

MPE assessment for LMR UHF - roof mounted antenna – Passenger Front

Blue fonts: Frequencies not regulated by FCC.

Trunk/ Roof	Test Position	E/H Field	Antenna No.	Antenna Model	Max Pwr (W)	Initial Pwr (W)	Tx Freq (MHz)	Max Calc. P.D. (mW/cm ²)	FCC Limit	% To FCC Spec Limit	ICNIRP Limit	% To ICNIRP Spec Limit	ISED Limit	% To ISED Spec Limit
Roof	PF	E	7	PMAE4039A, 1/4 Wave (403-430 MHz)	48.0	46.7	403.0125	0.01	0.27	3.0	0.20	4.0	0.16	5.1
						46.6	406.1250	0.01	0.27	3.2	0.20	4.3	0.16	5.5
						47.0	416.5000	0.02	0.28	7.1	0.21	9.4	0.16	12.2
						47.1	429.9875	0.02	0.29	5.2	0.21	7.0	0.17	9.1
			8	PMAE4040A, 1/4 Wave (406-420 MHz)	48.0	46.6	406.1250	0.04	0.27	16.4	0.20	21.9	0.16	27.9
						47.2	413.0125	0.05	0.28	19.0	0.21	25.3	0.16	32.5
						46.8	419.9875	0.05	0.28	17.8	0.21	23.7	0.16	30.6
			9	PMAE4041A, 1/4 Wave (450-470 MHz)	48.0	47.4	450.0125	0.00	0.30	1.0	0.23	1.3	0.17	1.7
						47.6	460.0125	0.00	0.31	1.2	0.23	1.6	0.17	2.2
						47.7	469.9875	0.00	0.31	1.4	0.23	1.8	0.18	2.5

17.2 Assessment of Bluetooth / WLAN Radio and Simultaneous Transmission

MPE calculation was used to determine power density for these transmitters due to lower power. According to FCC’s OET Bulletin 65 Edition 97-01 Section 2, calculations can be made to predict RF field strength and power density levels around typical RF sources. Equation (5) is generally accurate in far-field of an antenna.

Equation 5 – Power Density Calculation

$$S = \frac{P_t G}{4\pi d^2} F$$

Equation (5) accounts for the maximum duty cycle of the signal, and the factor, F, to provide a worst-case prediction of power density per FCC OET Bulletin 65, Edition 97-01 1997.

- Where:
- S = power density
 - P_t = maximum output power scaled by the maximum duty cycle of the signal
 - G = power gain of the antenna in the direction of interest relative to an isotropic radiator
 - d = distance from antenna
 - F = Enhancement factor [1 or 2.56 for predicting ground-level field strength]

Table 14 summarized the MPE calculation for each standalone transmitter bands, Bluetooth and WLAN.

**Table 14
(FCC/ISED)**

Antenna #	Max Power (W)	Duty Cycle (%)	Tx Frequency (MHz)	Antenna Gain (dBi)	Cable Loss, L (dB)	Dist., d (cm)	⁽⁴⁾ Enhance Factor, F	Max Calc. MPE (mW/cm ²)	MPE Spec Limit (mW/cm ²)			
									FCC limit	% To FCC Spec Limit	ISED limit	% To ISED Spec Limit
WLAN 2.4 GHz												
<u>NA Regions</u>												
Internal Antenna	0.018	99.80%	2412.0	4.00	0.00	20	1.00	0.009	1.00	0.89	0.54	1.65
Internal Antenna	0.018	99.80%	2437.0	4.00	0.00	20	1.00	0.009	1.00	0.89	0.54	1.64
Internal Antenna	0.018	99.80%	2462.0	4.00	0.00	20	1.00	0.009	1.00	0.89	0.54	1.63
Bluetooth												
<u>NA Regions</u>												
Internal Antenna	0.004	77.00%	2402.0	4.00	0.00	20	1.00	0.002	1.00	0.15	0.54	0.29
Internal Antenna	0.004	77.00%	2441.0	4.00	0.00	20	1.00	0.002	1.00	0.15	0.54	0.28
Internal Antenna	0.004	77.00%	2480.0	4.00	0.00	20	1.00	0.002	1.00	0.15	0.55	0.28

(ICNIRP)

Antenna #	Max Power (W)	Duty Cycle (%)	Tx Frequency (MHz)	Antenna Gain (dBi)	Cable Loss, L (dB)	Dist., d (cm)	⁽⁴⁾ Enhance Factor, F	Max Calc. MPE (mW/cm ²)	MPE Spec Limit (mW/cm ²)	
									ICNIRP limit	% To ICNIRP Spec Limit
<u>WLAN 2.4 GHz</u>										
<u>Other Regions</u>										
Internal Antenna	0.030	99.80%	2412.0	4.00	0.00	20	1.00	0.015	1.00	1.51
Internal Antenna	0.030	99.80%	2437.0	4.00	0.00	20	1.00	0.015	1.00	1.51
Internal Antenna	0.030	99.80%	2462.0	4.00	0.00	20	1.00	0.015	1.00	1.51
<u>Bluetooth</u>										
<u>Other Regions</u>										
Internal Antenna	0.003	77.00%	2402.0	4.00	0.00	20	1.00	0.001	1.00	0.12
Internal Antenna	0.003	77.00%	2441.0	4.00	0.00	20	1.00	0.001	1.00	0.12
Internal Antenna	0.003	77.00%	2480.0	4.00	0.00	20	1.00	0.001	1.00	0.12

Notes:

- 1) Distance from antenna (d), 20cm for more conservative estimation.
- 2) Cable loss (L), all cable loss include in antenna gain, so should be 0 dB.
- 3) Enhancement Factor (F), 1 (Ground reflection already factor in during antenna characterization)

17.3 Simultaneous Transmission

LMR bands can transmit simultaneously with Bluetooth or WLAN 2.4 GHz. The highest percentage of limit for each standalone transmitters indicated in Table 15.

Table 15

Transmitters	Frequency Band (MHz)	Highest Percentage of Limit (%)		
		Passenger, Front Seat (PF)	Passenger, Back Seat (PB)	Bystander (BS)
FCC US				
LMR UHF	406.1-470	54.7 %	92.5 %	49.7 %
Bluetooth	2402 - 2480	0.15 %	0.15 %	0.15 %
WLAN 2.4 GHz	2412 - 2462	0.89 %	0.89 %	0.89 %
ISED Canada				
LMR UHF	406.1-430, 450-470	96.5 %	159.4 %	87.5 %
Bluetooth	2402 - 2480	0.29 %	0.29 %	0.29 %
WLAN 2.4 GHz	2412 - 2462	1.65 %	1.65 %	1.65 %
ICNIRP				
LMR UHF	403-470	72.9 %	123.3 %	66.2 %
Bluetooth	2402 - 2480	0.12 %	0.12 %	0.12 %
WLAN 2.4 GHz	2412 - 2484	1.51 %	1.51 %	1.51 %

Per KDB 447498 D01, simultaneous transmission MPE test exclusion applies when the sum of MPE ratios for all simultaneous transmitting antennas incorporated in a host device is ≤ 1.0 , according to calculated/estimated, numerically modeled, or measured field strengths or power density.

Calculated Maximum Power density for WLAN 2.4 and Bluetooth. WLAN 2.4 GHz and Bluetooth transmitters cannot transmit at the same time. Thus, WLAN 2.4 GHz will be used to evaluate simultaneous transmission test exclusion. The highest combined power density percentage for simultaneous transmission indicated in Table 16.

Table 16

Designator	Simultaneous Transmission Scenario	Highest Combined Percentage of Limit (%)		
		Passenger, Front Seat (PF)	Passenger, Back Seat (PB)	Bystander (BS)
FCC	LMR and WLAN	55.59 %	93.39 %	50.59 %
ISED Canada	LMR and WLAN	98.15 %	161.05 %	89.15 %
ICNIRP	LMR and WLAN	74.41 %	124.80 %	67.71 %

18.0 Conclusion

The assessments for this device were performed with an output power range as indicated in section 17.1. The maximum allowable output power is equal to the upper limit of the final test factory transmit power specification listed in Table 6. The highest power density results for LMR transmitters scaled to maximum allowable power output are indicated in Table 14 for internal/passenger to the vehicle, and external/bystander to the vehicle.

Table 17: Maximum MPE RF Exposure Summary (LMR)

Designator	Transmitters	Frequency Band (MHz)	Passenger (mW/cm ²)	Bystander (mW/cm ²)
FCC	LMR UHF	406.1-470	0.26	0.15
ISED Canada	LMR UHF	406.1-430, 450-470	0.26	0.15
ICNIRP	LMR UHF	403-470	0.26	0.15

Table 18: Maximum MPE RF Exposure Summary (BT/WLAN)

Designator	Transmitters	Frequency Band (MHz)	Passenger (mW/cm ²)	Bystander (mW/cm ²)
FCC / ISED Canada	Bluetooth	2402 – 2480	0.002	0.002
ICNIRP	Bluetooth	2402 – 2480	0.001	0.001
FCC / ISED Canada	2.4 GHz WLAN	2412-2462	0.009	0.009
ICNIRP	2.4 GHz WLAN	2412-2484	0.015	0.015

These MPE results herein demonstrate compliance to the FCC US, ISED Canada and ICNIRP Occupational/Controlled Exposure limit. FCC rules require compliance for Passengers and Bystanders to the FCC General Population/Uncontrolled limits.

Although MPE is a convenient method of demonstrating RF Exposure requirements, SAR is recognized as the “basic restriction”. For those configurations in Table 8-13 with ‘*’, compliance to the General Population / Uncontrolled SAR 1g limit of 1.6 W/kg is demonstrated through SAR computational analysis.

The computational results show that this device, when used with the offered antennas in accordance with the user manual instructions, exhibits the maximum peak average SAR values indicated in the Table below for the configurations requiring SAR analysis.

Table 19

Designator	Exposure Conditions	Maximum peak average SAR (1g)
ISED Canada	Passenger	0.63 W/kg
ICNIRP	Passenger	0.46 W/kg

19.0 User Instructions Considerations

In order to facilitate the task of professional users, the Safety Manual for this radio requires that bystanders be kept at least 3 ft (90 cm) from the vehicle Body.

Appendix A - Antenna Locations, Test Distances, and Cable Losses

Antenna locations

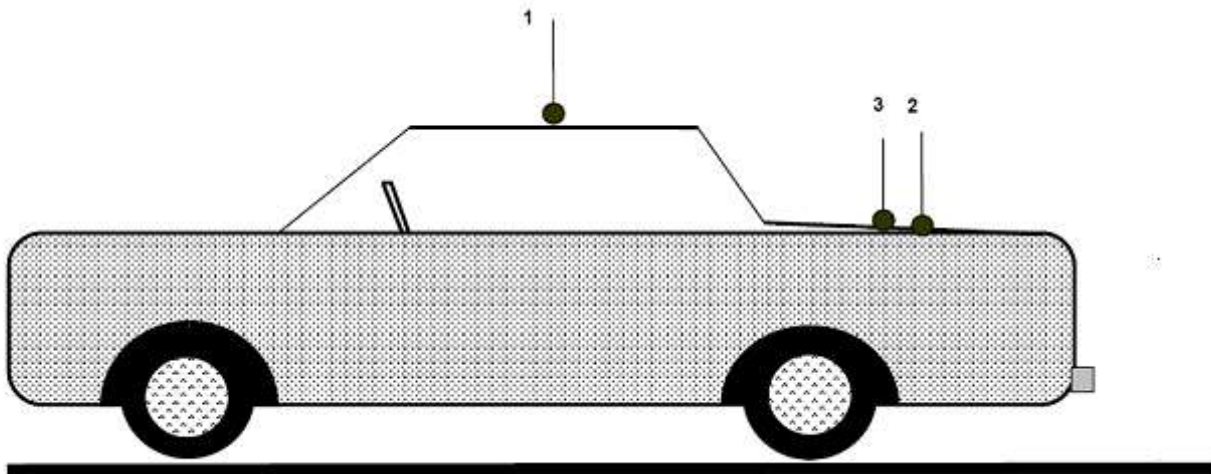

1. Roof (20cm from center)
2. Trunk (85cm from back of the back seat)
3. Trunk (center)

Passenger Antenna mounting

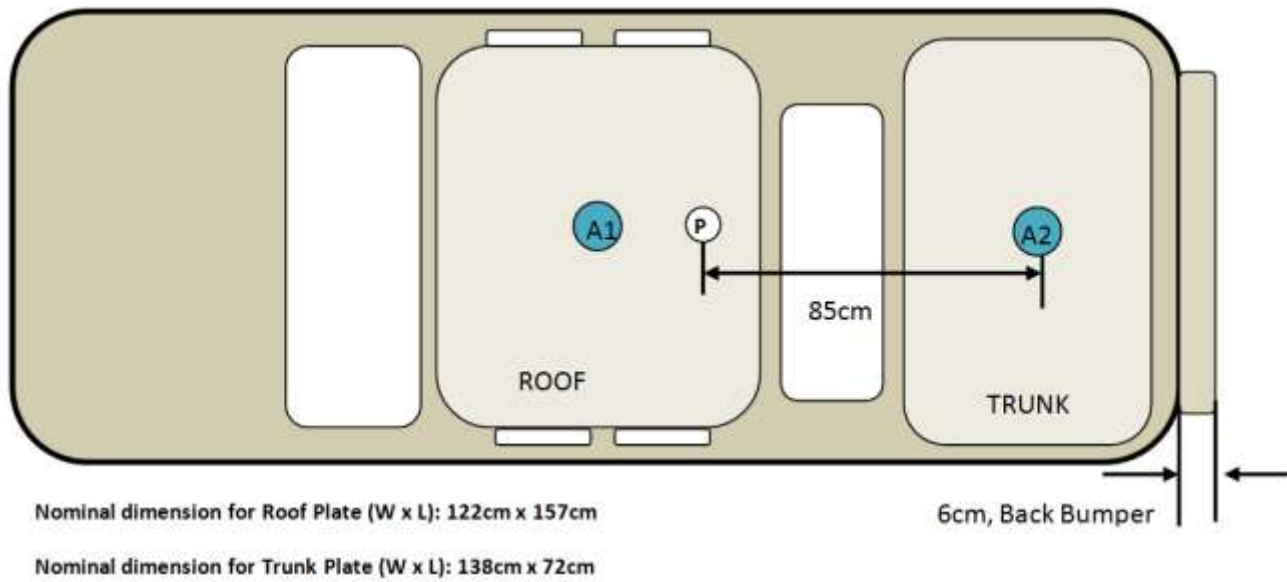

Notes:

- 1.) Antenna location A1: Mobile radio roof antenna mounting locations for front and back passenger testing
- 2.) Antenna location A2: Mobile radio trunk antenna mounting locations for front and back passenger testing
- 3.) Total distance between trunk mount antenna and rear passenger is 85cm

Bystander Antenna mounting

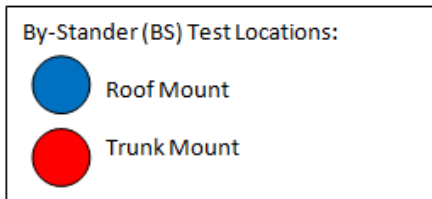
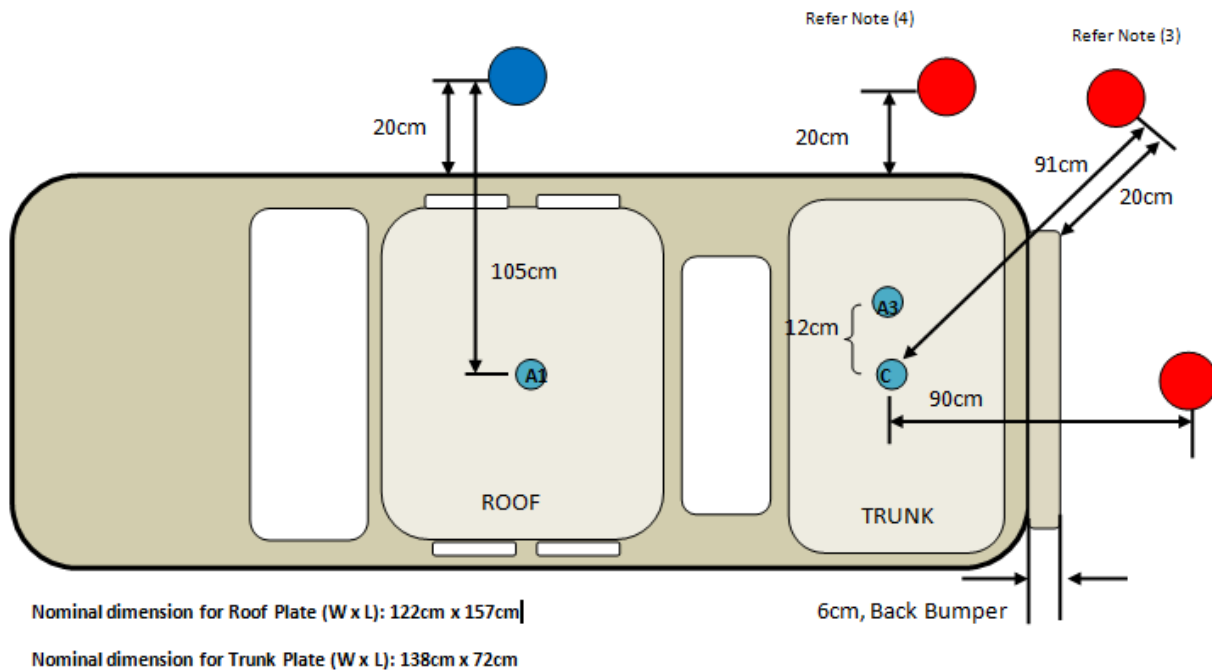

Notes:

- 1) Antenna location A1: Mobile radio roof antenna mounting location
- 2) Antenna location A3: Mobile radio trunk antenna mounting location for bystander testing. (12cm away from the center)
- 3) Total distance between Bystander 45 degree angles from the centered-trunk mount antenna is 91cm to maintain a minimum 20cm separation between probe sensor and vehicle body.
- 4) Total distance between Bystander 90 degree angle from the centered-trunk mount antenna is 90cm (by moving antenna location A3 12 cm from center of the trunk)

Seat scan areas (Applicable to both front and back seats)

Meter - Probe

 Probe diameter is 5.5cm

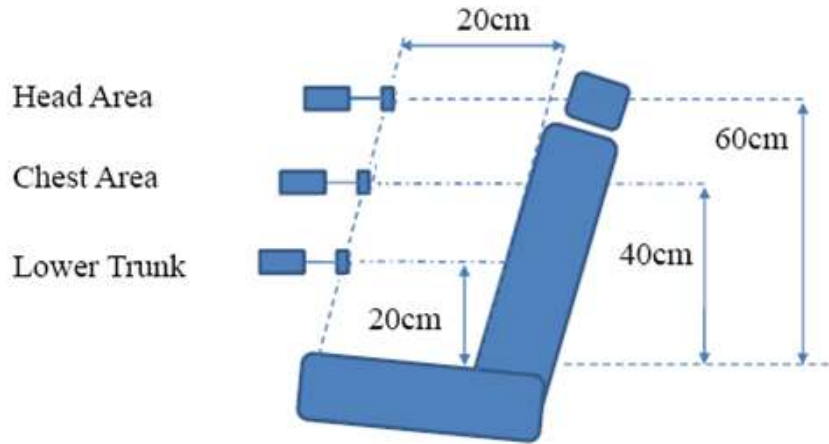

Cable Losses

Test Cable

Teflon RG58A/U Loss Per 100 Feet

160 MHz - 5 dB

450 MHz - 9 dB

1 GHz - 13.8 dB

Customer Cable

RG-58A/U Loss Per 100 Feet (For LMR)

136 MHz – 5.5 dB

450 MHz – 9.6 dB

900 MHz – 13.9 dB

PPF 240 Loss Per 100 Feet (For BT/WLAN)

2500 MHz - 12.9 dB

5800 MHz -20.4 dB

Appendix B - Probe Calibration Certificates

Service Test Report
QAF 1126, 03/11
Report ID: 134653



Certificate of Test Conformance Page 1 of 1

Reference: S 000048638

Customer: Motorola Solutions Malaysia Sdn Bhd - Plot 2A, Medan Bayan Lepas, Mukim 12
S.W.D. - Bayan Lepas - Penang 11900 - Malaysia

The instrument listed below has been tested and verified to Internal Quality Standards. Test data is Attached. Equipment used during instrument testing is controlled by laboratory compliance with ISO/IEC 17025-2017 and ANSI/NCSL Z540-1-1994 using ETS-Lindgren Quality Management System internal procedures.

<u>Manufacturer</u>	ETS-Lindgren	<u>Status In</u>	In Tolerance
<u>Instrument Type</u>	RF Survey Meter	<u>Date Completed</u>	06-May-20
<u>Model</u>	HI-2200	<u>Status Out</u>	Compliant with Internal Quality Standards
<u>Serial Number/ID</u>	00086887		

Remarks

Performed functional test with E100 sn 00224511 and H200 sn 00224521. Unit had Firmware #2.32 Upgrade. Alt ID: MS10201.

I would like to take this opportunity to express our appreciation for using ETS-Lindgren for your EMI test equipment services and I am looking forward to continued business with your organization. Please feel free to contact our offices at (512) 531-6400, if you have any questions regarding this report.

Sincerely,

 George Cisneros
 Calibration Supervisor

Date Attested: 06-May-20



1301 Arrow Point Drive
Cedar Park, Texas 78613
(512) 531-6400



Cert I.D.: 134651

Certificate of Calibration Conformance

Page 1 of 3

The instrument identified below has been individually calibrated in compliance with the following standard(s):

IEEE 1309 - 2013, Institute of Electrical and Electronics Engineers, Standard for Calibration of Electromagnetic Field Sensors and Probes, Excluding Antennas from 9 kHz to 40 GHz.

Environment: Laboratory MTE is maintained in a temperature controlled environment with ambient conditions from 18 to 28 C, relative humidity less than 90%. The instrument under test has been calibrated in a suitable environment using an EMCO TEM Cell 5101C, GTEM 5305/5402 and an RF Shielded EMC Chamber which is conducive to maintaining accurate and reliable measurement quality.

Manufacturer:	ETS-Lindgren	Operating Range:	100kHz - 5GHz
Model Number:	E100	Instrument Type:	Isotropic Probe > 1 GHz
Serial Number ID:	00224511	Date Code:	
Tracking Number:	S 000048636	Alternate ID:	MS10428
Date Completed:	06-May-20	Customer:	Motorola Solutions Malaysia Sdn Bhd - Plot 2A, Medan Bayan Lepas, Mukim 12 S.W.D. - Bayan Lepas - Penang 11900 - Malaysia
Test Type:	Standard Field, Field Strength		

Calibration Uncertainty: Std Field Method 100kHz - 6 GHz, +/-0.64 dB, Linearity +/- 0.95 dB, Isotropically +/- 0.86
k=2, (95% Confidence Level)

Test Remarks: Probe received in tolerance thus before and after data are the same. Calibration performed with customer's HI-2200 sn 00066887.

Calibration Traceability: All Measuring and Test Equipment (MTE) identified below are traceable to the SI units through the National Institute for Standards and Technology (NIST) or other recognized National Metrology Institute. Calibration Laboratory and Quality System controls are compliant with ISO/IEC 17025-2017 and ANSI/NCSL Z540-1-1994.

Standards and Equipment Used:

Make / Model / Name / S/N / Calibration Date	Condition of Instrument Upon Receipt:
HP 8648C Signal Generator 3836U02236 04-May-21	In Tolerance to Internal Quality Standards
Keysight E9304A Power Sensor MY56100039 16-Apr-21	On Release: In Tolerance to Internal Quality Standards
Hewlett Packard E4422B Signal Generator US40050591 09-Aug-20	
Agilent E9304A Power Sensor MY41499013 16-Apr-21	
Agilent E9304A Power Sensor MY41499012 16-Apr-21	
Rohde & Schwarz NRP-Z91 Power Sensor 100733 06-Mar-21	
Agilent E4419B Power Meter MY40510693 08-Aug-20	
Agilent N1913A Power Meter MY50000415 16-Mar-21	
Marconi 2024 Signal Generator 112343/043 04-May-21	
Rohde & Schwarz NRVD Power Meter 828110/019 09-Jan-21	
Hewlett Packard E4419B Power Meter US39250717 14-Aug-20	
Keysight E9304A Power Sensor MY56100005 16-Apr-21	
Rohde & Schwarz NRV-Z55 Thermal Power Sensor 100352 20-Sep-20	
Rohde & Schwarz NRV-Z55 Thermal Power Sensor 100037 22-Oct-20	
Rohde & Schwarz NRP-Z91 Power Sensor 100734 01-Aug-20	
Keysight N5183B MXG Analog Signal Gener MY53270789 08-Feb-21	

Julio Aquino
 Calibration Completed By
 Julio A. Aquino, Calibration Technician

George Chimeros
 Attested and Issued on 06-May-20
 George Chimeros, Calibration Supervisor

This document provides traceability of measurements to recognized national standards using controlled processes at the ETS-Lindgren Calibration Laboratory. Uncertainties listed are derived from the methods described by NIST Tech Note 1297. This certificate and report may not be reproduced, except in full, without the written approval of ETS-Lindgren Calibration Laboratory in accordance with ISO/IEC 17025-2017 and ANSI/NCSL Z540-1-1994. The results in this document relate only to the item(s) listed and should not be considered representative of a population unless otherwise noted. QAF 1127 (02/11)

CALIBRATION REPORT

Electric Field Sensor

Model	S/N
E100	00224511
HI-2200	00086887

Date: 06 May 2020

- New Instrument
- Other
- Out of Tolerance
- Within Tolerance

Frequency Response

Frequency Response	MHz	Nominal Field V/m	Cal Factor* (Applied/Indicated)	Deviation dB
1	0.1	20	1.45	-3.22
2	0.5	20	1.12	-1.01
3	1	20	1.05	-0.43
4	3	20	1.00	-0.03
5	15	20	1.00	0.00
6	27.12	20	1.01	-0.05
7	30	20	1.00	-0.04
8	75	20	1.01	-0.07
9	100	20	1.01	-0.11
10	150	20	1.01	-0.10
11	200	20	1.00	-0.03
12	250	20	1.00	-0.04
13	300	20	0.99	0.08
14	400	20	1.01	-0.05
15	500	20	1.05	-0.46
16	600	20	1.05	-0.43
17	700	20	1.08	-0.65
18	800	20	1.10	-0.81
19	900	20	1.05	-0.39
20	1000	20	1.00	0.00
21	2000	20	1.04	-0.32
22	2450	20	1.04	-0.38
23	3000	20	0.96	0.39
24	3500	20	0.90	0.91
25	4000	20	0.99	0.10
26	5000	20	1.01	-0.08
27	5500	20	1.25	-1.93
28	6000	20	1.33	-2.47

* Corrected electric field values (V/m) can be obtained by multiplying the Cal Factor with the indicated E field readings.

Linearity

maximum linearity deviation is 0.42 dB
(measurements taken from 0.3 V/m to 800 V/m at 27.12 MHz)

Test Conditions

Calibration performed at ambient room temperature: 23 ±3°C



PROBE ROTATIONAL RESPONSE

Model E100
S/N 00224511
Report S00048638
Date Date of Calibration 06 May 2020
Time 08:45:13 AM
Isotropy * + 0.308 dB/ -0.308 dB

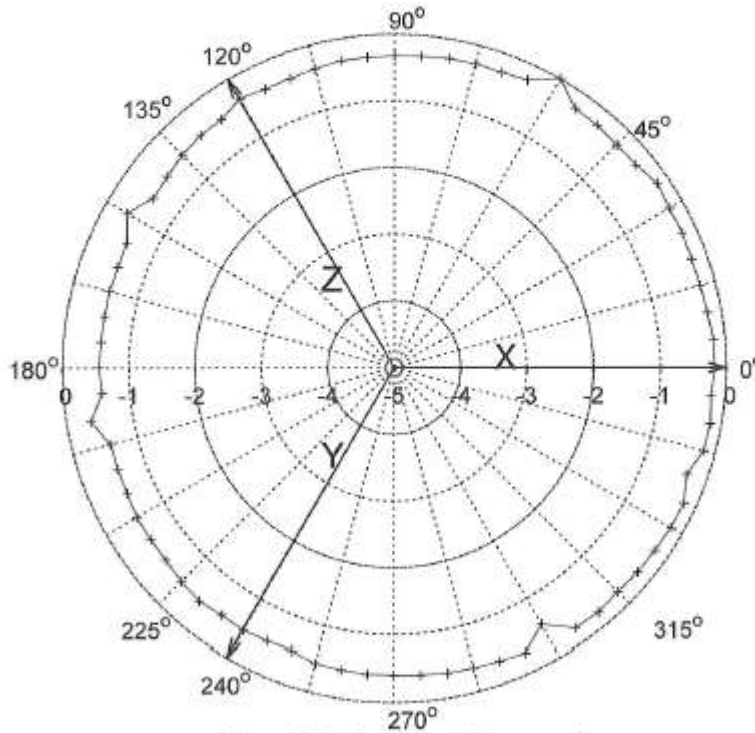

Figure 1: Probe Isotropic Response Chart.

Isotropic response is measured in a 20 V/m field at 400 MHz.
*Isotropy is the maximum deviation from the geometric mean as defined by IEEE 1309-2013.



Cert I.D.: 134652

Certificate of Calibration Conformance

Page 1 of 2

The instrument identified below has been individually calibrated in compliance with the following standard(s):

IEEE 1309 - 2013, Institute of Electrical and Electronics Engineers, Standard for Calibration of Electromagnetic Field Sensors and Probes, Excluding Antennas from 9 kHz to 40 GHz

Environment: Laboratory MTE is maintained in a temperature controlled environment with ambient conditions from 18 to 28 C, relative humidity less than 90%. The instrument under test has been calibrated in a suitable environment using an EMCO TEM Cell 5101C, GTEM 5305/5402 and an RF Shielded EMC Chamber which is conducive to maintaining accurate and reliable measurement quality.

Manufacturer:	ETS-Lindgren	Operating Range:	5-300MHz / 30mA/m-10A/m
Model Number:	H200	Instrument Type:	Isotropic Magnetic Field Probe (2)
Serial Number/ ID:	00224521	Date Code:	
Tracking Number:	S 000048638	Alternate ID:	MS10429
Date Completed:	06-May-20	Customer:	Motorola Solutions Malaysia Sdn Bhd - Plot 2A, Medan Bayan Lepas, Mukim 12 S.W.D. - Bayan Lepas - Penang 11900 - Malaysia
Test Type:	Standard Field, Field Strength		

Calibration Uncertainty: Direct Field Method 1.15dB
k=2, (95% Confidence Level)

Test Remarks: Probe received in tolerance thus before and after data are the same. Probe was tested with customer's HI-2200 sn 00086887.

Calibration Traceability: All Measuring and Test Equipment (MTE) identified below are traceable to the SI units through the National Institute for Standards and Technology (NIST) or other recognized National Metrology Institute. Calibration Laboratory and Quality System controls are compliant with ISO/IEC 17025-2017 and ANSI/NCSL Z540-1-1994.

Standards and Equipment Used:

Make / Model / Name / S/N / Calibration Date				Condition of Instrument Upon Receipt:
HP	8648C	Signal Generator	3836U02236 04-May-21	In Tolerance to Internal Quality Standards
Keysight	E9304A	Power Sensor	MY56100039 16-Apr-21	On Release: In Tolerance to Internal Quality Standards
Hewlett Packard	E4422B	Signal Generator	US40050591 09-Aug-20	
Agilent	E9304A	Power Sensor	MY41489013 16-Apr-21	
Agilent	E9304A	Power Sensor	MY41489012 16-Apr-21	
Rohde & Schwarz	NRP-Z91	Power Sensor	100733 06-Mar-21	
Agilent	E4419B	Power Meter	MY40510893 08-Aug-20	
Agilent	N1913A	Power Meter	MY50000415 16-Mar-21	

Julio A. Aquino
 Calibration Completed By
 Julio A. Aquino, Calibration Technician

George Cameros
 Attested and Issued on 06-May-20
 George Cameros, Calibration Supervisor

This document provides traceability of measurements to recognized national standards using controlled processes at the ETS-Lindgren Calibration Laboratory. Uncertainties listed are derived from the methods described by NIST Tech Note 1597. This certificate and report may not be reproduced, except in full, without the written approval of ETS-Lindgren Calibration Laboratory in accordance with ISO/IEC 17025-2017 and ANSI/NCSL Z540-1-1994. The results in this document relate only to the item(s) listed and should not be considered representative of a population unless otherwise noted. QAF 1127 (03/11)

CALIBRATION REPORT

Magnetic Field Sensor

Model	S/N
H200	00224521
HI-2200	00086887

Date: 06 May 2020

- New Instrument
- Other
- Out of Tolerance
- X Within Tolerance

Frequency Response

Frequency Response	Nominal Field	Cal Factor*	Deviation
MHz	A/m	(Applied/Indicated)	dB
1	5	1.20	-1.57
2	6	1.14	-1.12
3	7	1.10	-0.83
4	8	1.08	-0.63
5	9	1.06	-0.48
6	10	1.04	-0.38
7	13.6	1.02	-0.17
8	15	1.02	-0.13
9	20	1.00	-0.04
10	27.1	1.00	0.04
11	30	0.99	0.06
12	40	0.98	0.14
13	50	0.98	0.16
14	60	0.97	0.27
15	70	0.97	0.27
16	75	0.97	0.28
17	80	0.96	0.32
18	90	0.96	0.31
19	100	0.94	0.53
20	150	0.84	1.53
21	175	0.79	2.00
22	200	0.73	2.73
23	250	0.54	5.41
24	300	0.34	9.44

* Corrected magnetic field values (A/m) can be obtained by multiplying the Cal Factor with the indicated H field readings.

Linearity

maximum linearity deviation is 0.32 dB
 (measurements taken from 30 mA/m to 9 A/m at 27.12 MHz)

Test Conditions

Calibration performed at ambient room temperature: 23 ±3°C
 The above sensor was calibrated to factory specifications. This calibration is performed per IEEE 1309 standard. All equipment used are traceable to US National Institute of Standards and Technology (NIST).

Appendix C - Photos of Assessed Antennas
(Refer to Exhibit 7B)

Appendix D - MPE Measurement Results

Table D.1
MPE Measurement Data for Bystander

D.U.T. Info.										Probe Info.		MPE Measurements										DUT Max. TX Factor	Avg. over Body (mW/cm2)	Calc. P.D. (mW/cm2)	Max Calc. P.D. (mW/cm2)
⁽²⁾ Ant Loc.	Ant. Model/ Desc.	Ant. Gain (dBi)	Ant. Meas. Dist. (cm)	Tx Freq (MHz)	⁽³⁾ Max Pwr (W)	Initial Pwr (W)	Test Mode	E/H Field	⁽⁴⁾ Probe Cal. Factor	⁽⁵⁾ Test Pos.	⁽⁶⁾ Meas. Unit	Bystander (BS) Positions													
												20 cm	40 cm	60 cm	80 cm	100 cm	120 cm	140 cm	160 cm	180 cm	200 cm				
Roof	HAE4002A, 1/4 Wave (403-430 MHz)	2.15	90	403.0125	48.0	46.7	CW	E	1.020	BS	2	0.010	0.012	0.023	0.031	0.069	0.097	0.164	0.283	0.395	0.375	0.5	0.149	0.074	0.076
Roof	HAE4002A, 1/4 Wave (403-430 MHz)	2.15	90	406.1250	48.0	46.6	CW	E	1.030	BS	2	0.008	0.008	0.019	0.025	0.059	0.094	0.201	0.309	0.347	0.315	0.5	0.143	0.071	0.073
Roof	HAE4002A, 1/4 Wave (403-430 MHz)	2.15	90	416.5000	48.0	47.0	CW	E	1.030	BS	2	0.005	0.008	0.016	0.035	0.078	0.127	0.222	0.349	0.369	0.321	0.5	0.158	0.079	0.080
Roof	HAE4002A, 1/4 Wave (403-430 MHz)	2.15	90	429.9875	48.0	47.1	CW	E	1.040	BS	2	0.009	0.009	0.022	0.052	0.078	0.105	0.168	0.333	0.395	0.353	0.5	0.158	0.079	0.081
Roof	HAE4003A, 1/4 Wave (450-470 MHz)	2.15	90	450.0125	48.0	47.4	CW	E	1.060	BS	2	0.007	0.013	0.014	0.037	0.050	0.083	0.224	0.281	0.376	0.383	0.5	0.156	0.078	0.079
Roof	HAE4003A, 1/4 Wave (450-470 MHz)	2.15	90	460.0125	48.0	47.6	CW	E	1.070	BS	2	0.004	0.012	0.023	0.052	0.073	0.134	0.268	0.382	0.423	0.364	0.5	0.186	0.093	0.094
Roof	HAE4003A, 1/4 Wave (450-470 MHz)	2.15	90	469.9875	48.0	47.7	CW	E	1.080	BS	2	0.006	0.008	0.015	0.036	0.061	0.141	0.250	0.320	0.347	0.295	0.5	0.160	0.080	0.080
Roof	HAE4010A, 5/8 Wave (406-420 MHz)	5.65	90	406.1250	48.0	46.6	CW	E	1.030	BS	2	0.000	0.001	0.001	0.002	0.005	0.013	0.058	0.182	0.299	0.267	0.5	0.085	0.043	0.044
Roof	HAE4010A, 5/8 Wave (406-420 MHz)	5.65	90	413.0125	48.0	47.2	CW	E	1.030	BS	2	0.000	0.001	0.001	0.003	0.007	0.012	0.065	0.182	0.282	0.234	0.5	0.081	0.041	0.041
Roof	HAE4010A, 5/8 Wave (406-420 MHz)	5.65	90	419.9875	48.0	46.8	CW	E	1.040	BS	2	0.001	0.001	0.003	0.003	0.005	0.008	0.033	0.110	0.176	0.157	0.5	0.052	0.026	0.027
Roof	HAE4011A, 1/2 Wave (450-470 MHz)	5.65	90	450.0125	48.0	47.4	CW	E	1.060	BS	2	0.001	0.002	0.005	0.022	0.014	0.029	0.096	0.258	0.386	0.405	0.5	0.129	0.065	0.065
Roof	HAE4011A, 1/2 Wave (450-470 MHz)	5.65	90	460.0125	48.0	47.6	CW	E	1.070	BS	2	0.001	0.001	0.003	0.006	0.028	0.019	0.094	0.212	0.305	0.259	0.5	0.099	0.050	0.050
Roof	HAE4011A, 1/2 Wave (450-470 MHz)	5.65	90	469.9875	48.0	47.7	CW	E	1.080	BS	2	0.001	0.001	0.001	0.004	0.006	0.018	0.054	0.126	0.181	0.167	0.5	0.060	0.030	0.030

MPE calculations are defined in section 15.0

Table D.1 (Continued)
MPE Measurement Data for Bystander

D.U.T. Info.										Probe Info.		MPE Measurements										DUT Max. TX Factor	Avg. over Body (mW/cm ²)	Calc. P.D. (mW/cm ²)	Max Calc. P.D. (mW/cm ²)
⁽²⁾ Ant Loc.	Ant. Model/ Desc.	Ant. Gain (dBi)	Ant. Meas. Dist. (cm)	Tx Freq (MHz)	⁽³⁾ Max Pwr (W)	Initial Pwr (W)	Test Mode	E/H Field	⁽⁴⁾ Probe Cal. Factor	⁽⁵⁾ Test Pos.	⁽⁶⁾ Meas. Unit	Bystander (BS) Positions													
												20 cm	40 cm	60 cm	80 cm	100 cm	120 cm	140 cm	160 cm	180 cm	200 cm				
Roof	HAE6022A, 1/2 Wave (403-527 MHz)	4.15	90	403.0125	48.0	46.7	CW	E	1.020	BS	2	0.011	0.012	0.022	0.032	0.066	0.105	0.194	0.347	0.459	0.399	0.5	0.168	0.084	0.086
Roof	HAE6022A, 1/2 Wave (403-527 MHz)	4.15	90	406.1250	48.0	46.6	CW	E	1.030	BS	2	0.006	0.006	0.015	0.028	0.070	0.102	0.213	0.340	0.393	0.324	0.5	0.154	0.077	0.079
Roof	HAE6022A, 1/2 Wave (403-527 MHz)	4.15	90	419.9875	48.0	46.8	CW	E	1.040	BS	2	0.007	0.013	0.045	0.057	0.087	0.137	0.205	0.413	0.390	0.301	0.5	0.172	0.086	0.088
Roof	HAE6022A, 1/2 Wave (403-527 MHz)	4.15	90	436.5000	48.0	47.0	CW	E	1.050	BS	2	0.013	0.011	0.020	0.049	0.058	0.094	0.213	0.360	0.390	0.337	0.5	0.162	0.081	0.083
Roof	HAE6022A, 1/2 Wave (403-527 MHz)	4.15	90	453.0125	48.0	47.5	CW	E	1.060	BS	2	0.004	0.009	0.015	0.038	0.063	0.128	0.239	0.375	0.359	0.262	0.5	0.158	0.079	0.080
Roof	HAE6022A, 1/2 Wave (403-527 MHz)	4.15	90	469.9875	48.0	47.7	CW	E	1.080	BS	2	0.007	0.014	0.020	0.038	0.055	0.135	0.256	0.359	0.370	0.299	0.5	0.168	0.084	0.084
Roof	HAE6029A, 1/2 Wave (403-527 MHz)	4.15	90	403.0125	48.0	46.7	CW	E	1.020	BS	2	0.010	0.010	0.016	0.027	0.073	0.101	0.181	0.345	0.435	0.376	0.5	0.161	0.080	0.083
Roof	HAE6029A, 1/2 Wave (403-527 MHz)	4.15	90	406.1250	48.0	46.6	CW	E	1.030	BS	2	0.009	0.008	0.010	0.025	0.058	0.097	0.201	0.341	0.386	0.318	0.5	0.150	0.075	0.077
Roof	HAE6029A, 1/2 Wave (403-527 MHz)	4.15	90	419.9875	48.0	46.8	CW	E	1.040	BS	2	0.008	0.010	0.028	0.057	0.096	0.133	0.235	0.373	0.394	0.298	0.5	0.170	0.085	0.087
Roof	HAE6029A, 1/2 Wave (403-527 MHz)	4.15	90	436.5000	48.0	47.0	CW	E	1.050	BS	2	0.015	0.012	0.020	0.042	0.056	0.101	0.215	0.364	0.399	0.332	0.5	0.163	0.082	0.083
Roof	HAE6029A, 1/2 Wave (403-527 MHz)	4.15	90	453.0125	48.0	47.5	CW	E	1.060	BS	2	0.006	0.011	0.021	0.040	0.064	0.128	0.244	0.373	0.352	0.259	0.5	0.159	0.079	0.080
Roof	HAE6029A, 1/2 Wave (403-527 MHz)	4.15	90	469.9875	48.0	47.7	CW	E	1.080	BS	2	0.009	0.014	0.021	0.031	0.059	0.147	0.257	0.366	0.376	0.290	0.5	0.170	0.085	0.085

MPE calculations are defined in section 15.0.

Table D.1 (Continued)
MPE measurement data for Bystander

D.U.T. Info.											Probe Info.		MPE Measurements										DUT Max. TX Factor	Avg. over Body (mW/cm2)	Calc. P.D. (mW/cm2)	Max Calc. P.D. (mW/cm2)
⁽²⁾ Ant Loc.	Ant. Model/ Desc.	Ant. Gain (dBi)	Ant. Meas. Dist. (cm)	Tx Freq (MHz)	⁽³⁾ Max Pwr (W)	Initial Pwr (W)	Test Mode	E/H Field	⁽⁴⁾ Probe Cal. Factor	⁽⁵⁾ Test Pos.	⁽⁶⁾ Meas. Unit	Bystander (BS) Positions														
												20 cm	40 cm	60 cm	80 cm	100 cm	120 cm	140 cm	160 cm	180 cm	200 cm					
Roof	PMAE4039A, 1/4 Wave (403-430 MHz)	2.15	90	403.0125	48.0	46.7	CW	E	1.020	BS	2	0.001	0.001	0.004	0.003	0.012	0.015	0.028	0.046	0.065	0.064	0.5	0.024	0.012	0.013	
Roof	PMAE4039A, 1/4 Wave (403-430 MHz)	2.15	90	406.1250	48.0	46.6	CW	E	1.030	BS	2	0.001	0.001	0.003	0.004	0.010	0.017	0.032	0.053	0.058	0.056	0.5	0.024	0.012	0.012	
Roof	PMAE4039A, 1/4 Wave (403-430 MHz)	2.15	90	416.5000	48.0	47.0	CW	E	1.030	BS	2	0.002	0.003	0.005	0.012	0.025	0.037	0.072	0.109	0.123	0.107	0.5	0.051	0.025	0.026	
Roof	PMAE4039A, 1/4 Wave (403-430 MHz)	3.15	90	429.9875	48.0	47.1	CW	E	1.040	BS	2	0.001	0.004	0.011	0.027	0.039	0.050	0.091	0.173	0.216	0.193	0.5	0.084	0.042	0.043	
Roof	PMAE4040A, 1/4 Wave (406-420 MHz)	4.65	90	406.1250	48.0	46.6	CW	E	1.030	BS	2	0.011	0.008	0.012	0.018	0.060	0.100	0.188	0.287	0.317	0.219	0.5	0.126	0.063	0.065	
Roof	PMAE4040A, 1/4 Wave (406-420 MHz)	4.65	90	413.0125	48.0	47.2	CW	E	1.030	BS	2	0.007	0.007	0.009	0.028	0.078	0.114	0.230	0.365	0.376	0.255	0.5	0.151	0.076	0.077	
Roof	PMAE4040A, 1/4 Wave (406-420 MHz)	4.65	90	419.9875	48.0	46.8	CW	E	1.040	BS	2	0.006	0.012	0.023	0.059	0.096	0.146	0.222	0.348	0.352	0.254	0.5	0.158	0.079	0.081	
Roof	PMAE4041A, 1/4 Wave (450-470 MHz)	2.15	90	450.0125	48.0	47.4	CW	E	1.060	BS	2	0.001	0.001	0.004	0.005	0.006	0.012	0.036	0.063	0.076	0.096	0.5	0.032	0.016	0.016	
Roof	PMAE4041A, 1/4 Wave (450-470 MHz)	2.15	90	460.0125	48.0	47.6	CW	E	1.070	BS	2	0.001	0.001	0.003	0.007	0.013	0.016	0.070	0.089	0.120	0.111	0.5	0.046	0.023	0.023	
Roof	PMAE4041A, 1/4 Wave (450-470 MHz)	2.15	90	469.9875	48.0	47.7	CW	E	1.080	BS	2	0.002	0.003	0.005	0.008	0.011	0.014	0.088	0.166	0.199	0.183	0.5	0.073	0.037	0.037	

MPE calculations are defined in section 15.0.

Table D.1 (Continued)
MPE measurement data for Bystander

D.U.T. Info.										Probe Info.		MPE Measurements										DUT Max. TX Factor	Avg. over Body (mW/cm2)	Calc. P.D. (mW/cm2)	Max. Calc. P.D. (mW/cm2)
⁽²⁾ Ant Loc.	Ant. Model/ Desc.	Ant. Gain (dBi)	Ant. Meas. Dist. (cm)	Tx Freq (MHz)	⁽³⁾ Max Pwr (W)	Initial Pwr (W)	Test Mode	E/H Field	⁽⁴⁾ Probe Cal. Factor	⁽⁵⁾ Test Pos.	⁽⁶⁾ Meas. Unit	Bystander (BS) Positions													
												20 cm	40 cm	60 cm	80 cm	100 cm	120 cm	140 cm	160 cm	180 cm	200 cm				
Roof	PMAE4042A, 5/8 Wave (450-470 MHz)	5.65	90	450.0125	48.0	47.4	CW	E	1.060	BS	2	0.005	0.013	0.018	0.033	0.058	0.101	0.201	0.294	0.300	0.250	0.5	0.135	0.067	0.068
Roof	PMAE4042A, 5/8 Wave (450-470 MHz)	5.65	90	460.0125	48.0	47.6	CW	E	1.070	BS	2	0.007	0.013	0.021	0.058	0.075	0.133	0.253	0.382	0.375	0.259	0.5	0.169	0.084	0.085
Roof	PMAE4042A, 5/8 Wave (450-470 MHz)	5.65	90	469.9875	48.0	47.7	CW	E	1.080	BS	2	0.008	0.012	0.022	0.038	0.064	0.156	0.293	0.362	0.354	0.263	0.5	0.170	0.085	0.085
Roof	PMAE4043A, 5/8 Wave (450-470 MHz)	7.15	90	450.0125	48.0	47.4	CW	E	1.060	BS	2	0.003	0.004	0.007	0.015	0.020	0.070	0.148	0.342	0.489	0.383	0.5	0.157	0.078	0.079
Roof	PMAE4043A, 5/8 Wave (450-470 MHz)	7.15	90	460.0125	48.0	47.6	CW	E	1.070	BS	2	0.001	0.005	0.006	0.016	0.024	0.057	0.183	0.412	0.523	0.391	0.5	0.173	0.087	0.087
Roof	PMAE4043A, 5/8 Wave (450-470 MHz)	7.15	90	469.9875	48.0	47.7	CW	E	1.080	BS	2	0.001	0.002	0.006	0.010	0.021	0.053	0.167	0.329	0.447	0.350	0.5	0.150	0.075	0.075
Roof	RAE4004ARB 5/8 Wave (445-470 MHz)	7.15	90	445.0125	48.0	47.1	CW	E	1.060	BS	2	0.001	0.002	0.003	0.007	0.007	0.005	0.023	0.146	0.360	0.397	0.5	0.101	0.050	0.051
Roof	RAE4004ARB 5/8 Wave (445-470 MHz)	7.15	90	450.0125	48.0	47.4	CW	E	1.060	BS	2	0.003	0.003	0.005	0.007	0.008	0.006	0.036	0.190	0.423	0.440	0.5	0.119	0.059	0.060
Roof	RAE4004ARB 5/8 Wave (445-470 MHz)	7.15	90	457.5000	48.0	47.6	CW	E	1.070	BS	2	0.003	0.002	0.005	0.010	0.010	0.019	0.102	0.280	0.475	0.421	0.5	0.142	0.071	0.072
Roof	RAE4004ARB 5/8 Wave (445-470 MHz)	7.15	90	460.0125	48.0	47.6	CW	E	1.070	BS	2	0.004	0.003	0.004	0.010	0.012	0.021	0.100	0.267	0.421	0.387	0.5	0.132	0.066	0.066
Roof	RAE4004ARB 5/8 Wave (445-470 MHz)	7.15	90	469.9875	48.0	47.7	CW	E	1.080	BS	2	0.004	0.005	0.005	0.010	0.014	0.025	0.099	0.234	0.365	0.329	0.5	0.118	0.059	0.059

MPE calculations are defined in section 15.0.

Table D.1 (Continued)
MPE measurement data for Bystander

D.U.T. Info.										Probe Info.		MPE Measurements										DUT Max. TX Factor	Avg. over Body (mW/cm ²)	Calc. P.D. (mW/cm ²)	Max Calc. P.D. (mW/cm ²)
⁽²⁾ Ant Loc.	Ant. Model/ Desc.	Ant. Gain (dBi)	Ant. Meas. Dist. (cm)	Tx Freq (MHz)	⁽³⁾ Max Pwr (W)	Initial Pwr (W)	Test Mode	E/H Field	⁽⁴⁾ Probe Cal. Factor	⁽⁵⁾ Test Pos.	⁽⁶⁾ Meas. Unit	Bystander (BS) Positions													
												20 cm	40 cm	60 cm	80 cm	100 cm	120 cm	140 cm	160 cm	180 cm	200 cm				
Trunk	HAE4010A, 5/8 Wave (406-420 MHz)	5.65	90	406.1250	48.0	46.6	CW	E	1.030	BS	2	0.014	0.007	0.007	0.034	0.159	0.414	0.470	0.234	0.095	0.131	0.5	0.161	0.081	0.083
Trunk	HAE4010A, 5/8 Wave (406-420 MHz)	5.65	90	413.0125	48.0	47.2	CW	E	1.030	BS	2	0.020	0.010	0.012	0.030	0.119	0.289	0.362	0.204	0.097	0.106	0.5	0.129	0.064	0.065
Trunk	HAE4010A, 5/8 Wave (406-420 MHz)	5.65	90	419.9875	48.0	46.8	CW	E	1.040	BS	2	0.013	0.010	0.010	0.019	0.078	0.199	0.214	0.115	0.046	0.060	0.5	0.079	0.040	0.041
Trunk	HAE4011A, 1/2 Wave (450-470 MHz)	5.65	90	450.0125	48.0	47.4	CW	E	1.060	BS	2	0.021	0.030	0.029	0.059	0.226	0.546	0.646	0.364	0.084	0.062	0.5	0.219	0.110	0.111
Trunk	HAE4011A, 1/2 Wave (450-470 MHz)	5.65	90	460.0125	48.0	47.6	CW	E	1.070	BS	2	0.011	0.014	0.017	0.028	0.174	0.374	0.418	0.236	0.043	0.055	0.5	0.147	0.073	0.074
Trunk	HAE4011A, 1/2 Wave (450-470 MHz)	5.65	90	469.9875	48.0	47.7	CW	E	1.080	BS	2	0.005	0.004	0.005	0.019	0.096	0.218	0.235	0.112	0.030	0.024	0.5	0.081	0.040	0.041
Trunk	HAE6022A, 1/2 Wave (403-527 MHz)	4.15	90	403.0125	48.0	46.7	CW	E	1.020	BS	2	0.142	0.114	0.161	0.147	0.184	0.369	0.370	0.356	0.272	0.171	0.5	0.233	0.117	0.120
Trunk	HAE6022A, 1/2 Wave (403-527 MHz)	4.15	90	406.1250	48.0	46.6	CW	E	1.030	BS	2	0.113	0.097	0.152	0.125	0.188	0.326	0.364	0.315	0.251	0.162	0.5	0.216	0.108	0.111
Trunk	HAE6022A, 1/2 Wave (403-527 MHz)	4.15	90	419.9875	48.0	46.8	CW	E	1.040	BS	2	0.085	0.067	0.099	0.118	0.231	0.382	0.347	0.271	0.171	0.090	0.5	0.194	0.097	0.099
Trunk	HAE6022A, 1/2 Wave (403-527 MHz)	4.15	90	436.5000	48.0	47.0	CW	E	1.050	BS	2	0.081	0.063	0.093	0.134	0.248	0.353	0.288	0.195	0.100	0.061	0.5	0.170	0.085	0.087
Trunk	HAE6022A, 1/2 Wave (403-527 MHz)	4.15	90	453.0125	48.0	47.5	CW	E	1.060	BS	2	0.096	0.070	0.100	0.122	0.298	0.561	0.551	0.360	0.170	0.075	0.5	0.255	0.127	0.129
Trunk	HAE6022A, 1/2 Wave (403-527 MHz)	4.15	90	469.9875	48.0	47.7	CW	E	1.080	BS	2	0.059	0.044	0.073	0.129	0.328	0.494	0.478	0.297	0.158	0.060	0.5	0.229	0.114	0.115

MPE calculations are defined in section 15.0.

Table D.1 (Continued)
MPE measurement data for Bystander

D.U.T. Info.										Probe Info.		MPE Measurements										DUT Max. TX Factor	Avg. over Body (mW/cm ²)	Calc. P.D. (mW/cm ²)	Max. Calc. P.D. (mW/cm ²)
⁽²⁾ Ant Loc.	Ant. Model/ Desc.	Ant. Gain (dBi)	Ant. Meas. Dist. (cm)	Tx Freq (MHz)	⁽³⁾ Max Pwr (W)	Initial Pwr (W)	Test Mode	E/H Field	⁽⁴⁾ Probe Cal. Factor	⁽⁵⁾ Test Pos.	⁽⁶⁾ Meas. Unit	Bystander (BS) Positions													
												20 cm	40 cm	60 cm	80 cm	100 cm	120 cm	140 cm	160 cm	180 cm	200 cm				
Trunk	HAE6029A, 1/2 Wave (403-527 MHz)	4.15	90	403.0125	48.0	46.7	CW	E	1.020	BS	2	0.105	0.108	0.164	0.145	0.222	0.334	0.399	0.354	0.262	0.166	0.5	0.230	0.115	0.118
Trunk	HAE6029A, 1/2 Wave (403-527 MHz)	4.15	90	406.1250	48.0	46.6	CW	E	1.030	BS	2	0.103	0.101	0.143	0.144	0.212	0.342	0.368	0.309	0.256	0.189	0.5	0.223	0.112	0.115
Trunk	HAE6029A, 1/2 Wave (403-527 MHz)	4.15	90	419.9875	48.0	46.8	CW	E	1.040	BS	2	0.083	0.064	0.092	0.139	0.274	0.358	0.340	0.272	0.171	0.088	0.5	0.196	0.098	0.100
Trunk	HAE6029A, 1/2 Wave (403-527 MHz)	4.15	90	436.5000	48.0	47.0	CW	E	1.050	BS	2	0.077	0.066	0.087	0.116	0.239	0.302	0.291	0.188	0.098	0.063	0.5	0.160	0.080	0.082
Trunk	HAE6029A, 1/2 Wave (403-527 MHz)	4.15	90	453.0125	48.0	47.5	CW	E	1.060	BS	2	0.092	0.064	0.087	0.114	0.303	0.456	0.556	0.349	0.166	0.074	0.5	0.240	0.120	0.121
Trunk	HAE6029A, 1/2 Wave (403-527 MHz)	4.15	90	469.9875	48.0	47.7	CW	E	1.080	BS	2	0.058	0.035	0.071	0.114	0.349	0.511	0.469	0.294	0.146	0.066	0.5	0.228	0.114	0.115
Trunk	PMAE4040A, 1/4 Wave (406-420 MHz)	4.65	90	406.1250	48.0	46.6	CW	E	1.030	BS	2	0.115	0.109	0.178	0.147	0.150	0.273	0.306	0.241	0.152	0.088	0.5	0.181	0.091	0.093
Trunk	PMAE4040A, 1/4 Wave (406-420 MHz)	4.65	90	413.0125	48.0	47.2	CW	E	1.030	BS	2	0.105	0.114	0.155	0.148	0.204	0.315	0.364	0.246	0.132	0.066	0.5	0.190	0.095	0.097
Trunk	PMAE4040A, 1/4 Wave (406-420 MHz)	4.65	90	419.9875	48.0	46.8	CW	E	1.040	BS	2	0.087	0.075	0.107	0.134	0.285	0.350	0.319	0.216	0.136	0.038	0.5	0.182	0.091	0.093
Trunk	PMAE4042A, 5/8 Wave (450-470 MHz)	5.65	90	450.0125	48.0	47.4	CW	E	1.060	BS	2	0.101	0.066	0.111	0.164	0.453	0.545	0.544	0.322	0.136	0.067	0.5	0.266	0.133	0.135
Trunk	PMAE4042A, 5/8 Wave (450-470 MHz)	5.65	90	460.0125	48.0	47.6	CW	E	1.070	BS	2	0.085	0.056	0.101	0.180	0.452	0.547	0.505	0.326	0.137	0.056	0.5	0.262	0.131	0.132
Trunk	PMAE4042A, 5/8 Wave (450-470 MHz)	5.65	90	469.9875	48.0	47.7	CW	E	1.080	BS	2	0.057	0.050	0.091	0.174	0.387	0.504	0.460	0.306	0.192	0.090	0.5	0.250	0.125	0.126

MPE calculations are defined in section 15.0.

Table D.1 (Continued)
MPE measurement data for Bystander

D.U.T. Info.										Probe Info.		MPE Measurements										DUT Max. TX Factor	Avg. over Body (mW/cm ²)	Calc. P.D. (mW/cm ²)	Max Calc. P.D. (mW/cm ²)
⁽²⁾ Ant Loc.	Ant. Model/ Desc.	Ant. Gain (dBi)	Ant. Meas. Dist. (cm)	Tx Freq (MHz)	⁽³⁾ Max Pwr (W)	Initial Pwr (W)	Test Mode	E/H Field	⁽⁴⁾ Probe Cal. Factor	⁽⁵⁾ Test Pos.	⁽⁶⁾ Meas. Unit	Bystander (BS) Positions													
												20 cm	40 cm	60 cm	80 cm	100 cm	120 cm	140 cm	160 cm	180 cm	200 cm				
Trunk	PMAE4043A, 5/8 Wave (450-470 MHz)	7.15	90	450.0125	48.0	47.4	CW	E	1.060	BS	2	0.048	0.047	0.082	0.094	0.329	0.722	0.836	0.449	0.105	0.064	0.5	0.294	0.147	0.149
Trunk	PMAE4043A, 5/8 Wave (450-470 MHz)	7.15	90	460.0125	48.0	47.6	CW	E	1.070	BS	2	0.035	0.026	0.045	0.091	0.329	0.712	0.790	0.378	0.079	0.057	0.5	0.272	0.136	0.137
Trunk	PMAE4043A, 5/8 Wave (450-470 MHz)	7.15	90	469.9875	48.0	47.7	CW	E	1.080	BS	2	0.017	0.014	0.027	0.056	0.233	0.604	0.642	0.347	0.089	0.038	0.5	0.223	0.112	0.112
Trunk	RAE4004ARB 5/8 Wave (445-470 MHz)	7.15	90	445.0125	48.0	47.1	CW	E	1.060	BS	2	0.034	0.032	0.029	0.048	0.065	0.268	0.509	0.457	0.273	0.273	0.5	0.211	0.105	0.107
Trunk	RAE4004ARB 5/8 Wave (445-470 MHz)	7.15	90	450.0125	48.0	47.4	CW	E	1.060	BS	2	0.047	0.034	0.036	0.054	0.135	0.315	0.524	0.475	0.254	0.205	0.5	0.220	0.110	0.112
Trunk	RAE4004ARB 5/8 Wave (445-470 MHz)	7.15	90	457.5000	48.0	47.6	CW	E	1.070	BS	2	0.042	0.035	0.038	0.076	0.214	0.485	0.602	0.467	0.203	0.127	0.5	0.245	0.122	0.123
Trunk	RAE4004ARB 5/8 Wave (445-470 MHz)	7.15	90	460.0125	48.0	47.6	CW	E	1.070	BS	2	0.038	0.031	0.036	0.096	0.225	0.473	0.582	0.370	0.124	0.068	0.5	0.219	0.109	0.110
Trunk	RAE4004ARB 5/8 Wave (445-470 MHz)	7.15	90	469.9875	48.0	47.7	CW	E	1.080	BS	2	0.032	0.033	0.030	0.108	0.212	0.463	0.535	0.351	0.082	0.048	0.5	0.205	0.102	0.103
Trunk	PMAE4043A, 5/8 Wave (450-470 MHz)	7.15	90	450.0125	48.0	47.4	CW	E	1.060	BS	2	0.048	0.047	0.082	0.094	0.329	0.722	0.836	0.449	0.105	0.064	0.5	0.294	0.147	0.149
Trunk	PMAE4043A, 5/8 Wave (450-470 MHz)	7.15	90	450.0125	48.0	47.4	CW	E	1.060	BS	2	0.048	0.047	0.082	0.094	0.329	0.722	0.836	0.449	0.105	0.064	0.5	0.294	0.147	0.149

MPE calculations are defined in section 15.0.

Table D.2
MPE measurement data for Passenger

D.U.T. Info.								Probe Info.		(5) Test Pos.	(6) Meas. Unit			DUT Max. TX Factor	Avg. over Body (mW/cm2)	Calc. P.D. (mW/cm2)	Max Calc. P.D. (mW/cm2)	
(2) Ant Loc.	Ant. Model/ Desc.	Ant. Gain (dBi)	Ant. Meas. Dist. (cm)	Tx Freq (MHz)	(3) Max Pwr (W)	Initial Pwr (W)	Test Mode	E/H Field	(4) Probe Cal. Factor		MPE Measurements							
												Head/ Top 1/3	Chest/ Middle 1/3					Lower Trunk/ Bottom 1/3
Roof	HAE4002A, 1/4 Wave (403-430 MHz)	2.15	NA	403.0125	48.0	46.7	CW	E	1.020	PB	2	0.052	0.090	0.120	0.5	0.089	0.045	0.046
Roof	HAE4002A, 1/4 Wave (403-430 MHz)	2.15	NA	406.1250	48.0	46.6	CW	E	1.030	PB	2	0.048	0.098	0.098	0.5	0.084	0.042	0.043
Roof	HAE4002A, 1/4 Wave (403-430 MHz)	2.15	NA	416.5000	48.0	47.0	CW	E	1.030	PB	2	0.038	0.078	0.076	0.5	0.066	0.033	0.034
Roof	HAE4002A, 1/4 Wave (403-430 MHz)	2.15	NA	429.9875	48.0	47.1	CW	E	1.040	PB	3	0.034	0.048	0.048	0.5	0.078	0.039	0.040
Roof	HAE4003A, 1/4 Wave (450-470 MHz)	2.15	NA	450.0125	48.0	47.4	CW	E	1.060	PB	2	0.078	0.107	0.152	0.5	0.119	0.060	0.060
Roof	HAE4003A, 1/4 Wave (450-470 MHz)	2.15	NA	460.0125	48.0	47.6	CW	E	1.070	PB	2	0.074	0.069	0.141	0.5	0.101	0.051	0.051
Roof	HAE4003A, 1/4 Wave (450-470 MHz)	2.15	NA	469.9875	48.0	47.7	CW	E	1.080	PB	2	0.059	0.086	0.079	0.5	0.081	0.040	0.041
Roof	HAE4010A, 5/8 Wave (406-420 MHz)	5.65	NA	406.1250	48.0	46.6	CW	E	1.030	PB	2	0.004	0.002	0.005	0.5	0.004	0.002	0.002
Roof	HAE4010A, 5/8 Wave (406-420 MHz)	5.65	NA	413.0125	48.0	47.2	CW	E	1.030	PB	2	0.007	0.003	0.005	0.5	0.005	0.003	0.003
Roof	HAE4010A, 5/8 Wave (406-420 MHz)	5.65	NA	419.9875	48.0	46.8	CW	E	1.040	PB	2	0.004	0.002	0.003	0.5	0.003	0.002	0.002
Roof	HAE4011A, 1/2 Wave (450-470 MHz)	5.65	NA	450.0125	48.0	47.4	CW	E	1.060	PB	2	0.022	0.030	0.037	0.5	0.031	0.016	0.016
Roof	HAE4011A, 1/2 Wave (450-470 MHz)	5.65	NA	460.0125	48.0	47.6	CW	E	1.070	PB	2	0.014	0.014	0.007	0.5	0.012	0.006	0.006
Roof	HAE4011A, 1/2 Wave (450-470 MHz)	5.65	NA	469.9875	48.0	47.7	CW	E	1.080	PB	2	0.014	0.013	0.008	0.5	0.013	0.006	0.006

MPE calculations are defined in section 15.0.

Table D.2 (Continued)
MPE measurement data for Passenger

⁽²⁾ Ant Loc.	D.U.T. Info.							Probe Info.		⁽⁵⁾ Test Pos.	MPE Measurements	⁽⁶⁾ Meas. Unit			DUT Max. TX Factor	Avg. over Body (mW/cm ²)	Calc. P.D. (mW/cm ²)	Max Calc. P.D. (mW/cm ²)
	Ant. Model/ Desc.	Ant. Gain (dBi)	Ant. Meas. Dist. (cm)	Tx Freq (MHz)	⁽³⁾ Max Pwr (W)	Initial Pwr (W)	Test Mode	E/H Field	⁽⁴⁾ Probe Cal. Factor									
												Head/ Top 1/3	Chest/ Middle 1/3	Lower Trunk/ Bottom 1/3				
Roof	HAE6022A, 1/2 Wave (403-527 MHz)	4.15	NA	403.0125	48.0	46.7	CW	E	1.020	PB	2	0.060	0.075	0.132	0.5	0.091	0.045	0.047
Roof	HAE6022A, 1/2 Wave (403-527 MHz)	4.15	NA	406.1250	48.0	46.6	CW	E	1.030	PB	2	0.049	0.084	0.096	0.5	0.079	0.039	0.040
Roof	HAE6022A, 1/2 Wave (403-527 MHz)	4.15	NA	419.9875	48.0	46.8	CW	E	1.040	PB	2	0.066	0.062	0.056	0.5	0.064	0.032	0.033
Roof	HAE6022A, 1/2 Wave (403-527 MHz)	4.15	NA	436.5000	48.0	47.0	CW	E	1.050	PB	2	0.063	0.073	0.067	0.5	0.071	0.036	0.036
Roof	HAE6022A, 1/2 Wave (403-527 MHz)	4.15	NA	453.0125	48.0	47.5	CW	E	1.060	PB	2	0.064	0.078	0.125	0.5	0.094	0.047	0.048
Roof	HAE6022A, 1/2 Wave (403-527 MHz)	4.15	NA	469.9875	48.0	47.7	CW	E	1.080	PB	2	0.066	0.057	0.059	0.5	0.066	0.033	0.033
Roof	HAE6029A, 1/2 Wave (403-527 MHz)	4.15	NA	403.0125	48.0	46.7	CW	E	1.020	PB	2	0.057	0.048	0.088	0.5	0.066	0.033	0.034
Roof	HAE6029A, 1/2 Wave (403-527 MHz)	4.15	NA	406.1250	48.0	46.6	CW	E	1.030	PB	2	0.042	0.086	0.092	0.5	0.076	0.038	0.039
Roof	HAE6029A, 1/2 Wave (403-527 MHz)	4.15	NA	419.9875	48.0	46.8	CW	E	1.040	PB	2	0.060	0.051	0.040	0.5	0.052	0.026	0.027
Roof	HAE6029A, 1/2 Wave (403-527 MHz)	4.15	NA	436.5000	48.0	47.0	CW	E	1.050	PB	2	0.048	0.062	0.036	0.5	0.051	0.026	0.026
Roof	HAE6029A, 1/2 Wave (403-527 MHz)	4.15	NA	453.0125	48.0	47.5	CW	E	1.060	PB	2	0.064	0.084	0.108	0.5	0.090	0.045	0.046
Roof	HAE6029A, 1/2 Wave (403-527 MHz)	4.15	NA	469.9875	48.0	47.7	CW	E	1.080	PB	2	0.067	0.082	0.088	0.5	0.085	0.043	0.043

MPE calculations are defined in section 15.0.

Table D.2 (Continued)
MPE measurement data for Passenger

D.U.T. Info.										Probe Info.		⁽⁶⁾ Meas. Unit			DUT Max. TX Factor	Avg. over Body (mW/cm ²)	Calc. P.D. (mW/cm ²)	Max Calc. P.D. (mW/cm ²)
⁽²⁾ Ant Loc.	Ant. Model/ Desc.	Ant. Gain (dBi)	Ant. Meas. Dist. (cm)	Tx Freq (MHz)	⁽³⁾ Max Pwr (W)	Initial Pwr (W)	Test Mode	E/H Field	⁽⁴⁾ Probe Cal. Factor	⁽⁵⁾ Test Pos.	MPE Measurements							
												Head/ Top 1/3	Chest/ Middle 1/3	Lower Trunk/ Bottom 1/3				
Roof	PMAE4039A, 1/4 Wave (403-430 MHz)	2.15	NA	403.0125	48.0	46.7	CW	E	1.020	PB	2	0.006	0.014	0.019	0.5	0.013	0.007	0.007
Roof	PMAE4039A, 1/4 Wave (403-430 MHz)	2.15	NA	406.1250	48.0	46.6	CW	E	1.030	PB	2	0.007	0.009	0.010	0.5	0.009	0.004	0.005
Roof	PMAE4039A, 1/4 Wave (403-430 MHz)	2.15	NA	416.5000	48.0	47.0	CW	E	1.030	PB	2	0.011	0.013	0.026	0.5	0.017	0.009	0.009
Roof	PMAE4039A, 1/4 Wave (403-430 MHz)	3.15	NA	429.9875	48.0	47.1	CW	E	1.040	PB	2	0.011	0.033	0.023	0.5	0.023	0.012	0.012
Roof	PMAE4040A, 1/4 Wave (406-420 MHz)	4.65	NA	406.1250	48.0	46.6	CW	E	1.030	PB	2	0.037	0.068	0.094	0.5	0.068	0.034	0.035
Roof	PMAE4040A, 1/4 Wave (406-420 MHz)	4.65	NA	413.0125	48.0	47.2	CW	E	1.030	PB	2	0.045	0.068	0.087	0.5	0.069	0.034	0.035
Roof	PMAE4040A, 1/4 Wave (406-420 MHz)	4.65	NA	419.9875	48.0	46.8	CW	E	1.040	PB	2	0.039	0.030	0.060	0.5	0.045	0.022	0.023
Roof	PMAE4041A, 1/4 Wave (450-470 MHz)	2.15	NA	450.0125	48.0	47.4	CW	E	1.060	PB	2	0.005	0.006	0.012	0.5	0.008	0.004	0.004
Roof	PMAE4041A, 1/4 Wave (450-470 MHz)	2.15	NA	460.0125	48.0	47.6	CW	E	1.070	PB	2	0.007	0.013	0.016	0.5	0.013	0.006	0.006
Roof	PMAE4041A, 1/4 Wave (450-470 MHz)	2.15	NA	469.9875	48.0	47.7	CW	E	1.080	PB	2	0.008	0.011	0.014	0.5	0.012	0.006	0.006

MPE calculations are defined in section 15.0.

Table D.2 (Continued)

MPE measurement data for Passenger

D.U.T. Info.										Probe Info.		⁽⁶⁾ Meas. Unit			DUT Max. TX Factor	Avg. over Body (mW/cm ²)	Calc. P.D. (mW/cm ²)	Max Calc. P.D. (mW/cm ²)
⁽²⁾ Ant Loc.	Ant. Model/ Desc.	Ant. Gain (dBi)	Ant. Meas. Dist. (cm)	Tx Freq (MHz)	⁽³⁾ Max Pwr (W)	Initial Pwr (W)	Test Mode	E/H Field	⁽⁴⁾ Probe Cal. Factor	⁽⁵⁾ Test Pos.	MPE Measurements							
												Head/ Top 1/3	Chest/ Middle 1/3	Lower Trunk/ Bottom 1/3				
Roof	PMAE4042A, 5/8 Wave (450-470 MHz)	5.65	NA	450.0125	48.0	47.4	CW	E	1.060	PB	2	0.075	0.082	0.109	0.5	0.094	0.047	0.048
Roof	PMAE4042A, 5/8 Wave (450-470 MHz)	5.65	NA	460.0125	48.0	47.6	CW	E	1.070	PB	2	0.059	0.087	0.132	0.5	0.099	0.050	0.050
Roof	PMAE4042A, 5/8 Wave (450-470 MHz)	5.65	NA	469.9875	48.0	47.7	CW	E	1.080	PB	2	0.059	0.087	0.088	0.5	0.084	0.042	0.042
Roof	PMAE4043A, 5/8 Wave (450-470 MHz)	7.15	NA	450.0125	48.0	47.4	CW	E	1.060	PB	2	0.043	0.038	0.037	0.5	0.042	0.021	0.021
Roof	PMAE4043A, 5/8 Wave (450-470 MHz)	7.15	NA	460.0125	48.0	47.6	CW	E	1.070	PB	2	0.021	0.038	0.037	0.5	0.034	0.017	0.017
Roof	PMAE4043A, 5/8 Wave (450-470 MHz)	7.15	NA	469.9875	48.0	47.7	CW	E	1.080	PB	2	0.030	0.039	0.020	0.5	0.032	0.016	0.016
Roof	RAE4004ARB 5/8 Wave (445-470 MHz)	7.15	NA	445.0125	48.0	47.1	CW	E	1.060	PB	2	0.006	0.009	0.014	0.5	0.010	0.005	0.005
Roof	RAE4004ARB 5/8 Wave (445-470 MHz)	7.15	NA	450.0125	48.0	47.4	CW	E	1.060	PB	2	0.008	0.009	0.018	0.5	0.012	0.006	0.006
Roof	RAE4004ARB 5/8 Wave (445-470 MHz)	7.15	NA	457.5000	48.0	47.6	CW	E	1.070	PB	2	0.011	0.017	0.027	0.5	0.020	0.010	0.010
Roof	RAE4004ARB 5/8 Wave (445-470 MHz)	7.15	NA	460.0125	48.0	47.6	CW	E	1.070	PB	2	0.011	0.015	0.020	0.5	0.016	0.008	0.008
Roof	RAE4004ARB 5/8 Wave (445-470 MHz)	7.15	NA	469.9875	48.0	47.7	CW	E	1.080	PB	2	0.013	0.013	0.015	0.5	0.015	0.007	0.007

MPE calculations are defined in section 15.0.

Table D.2 (Continued)
MPE measurement data for Passenger

D.U.T. Info.										Probe Info.		⁽⁶⁾ Meas. Unit			DUT Max. TX Factor	Avg. over Body (mW/cm ²)	Calc. P.D. (mW/cm ²)	Max Calc. P.D. (mW/cm ²)
⁽²⁾ Ant Loc.	Ant. Model/ Desc.	Ant. Gain (dBi)	Ant. Meas. Dist. (cm)	Tx Freq (MHz)	⁽³⁾ Max Pwr (W)	Initial Pwr (W)	Test Mode	E/H Field	⁽⁴⁾ Probe Cal. Factor	⁽⁵⁾ Test Pos.	MPE Measurements							
												Head/ Top 1/3	Chest/ Middle 1/3	Lower Trunk/ Bottom 1/3				
Trunk	HAE4010A, 5/8 Wave (406-420 MHz)	5.65	NA	406.1250	48.0	46.6	CW	E	1.030	PB	2	0.136	0.216	0.066	0.5	0.144	0.072	0.074
Trunk	HAE4010A, 5/8 Wave (406-420 MHz)	5.65	NA	413.0125	48.0	47.2	CW	E	1.030	PB	2	0.086	0.112	0.061	0.5	0.089	0.044	0.045
Trunk	HAE4010A, 5/8 Wave (406-420 MHz)	5.65	NA	419.9875	48.0	46.8	CW	E	1.040	PB	2	0.059	0.073	0.046	0.5	0.062	0.031	0.032
Trunk	HAE4011A, 1/2 Wave (450-470 MHz)	5.65	NA	450.0125	48.0	47.4	CW	E	1.060	PB	2	0.471	0.200	0.181	0.5	0.301	0.151	0.152
Trunk	HAE4011A, 1/2 Wave (450-470 MHz)	5.65	NA	460.0125	48.0	47.6	CW	E	1.070	PB	2	0.340	0.134	0.166	0.5	0.228	0.114	0.115
Trunk	HAE4011A, 1/2 Wave (450-470 MHz)	5.65	NA	469.9875	48.0	47.7	CW	E	1.080	PB	2	0.241	0.073	0.097	0.5	0.148	0.074	0.074
Trunk	HAE6022A, 1/2 Wave (403-527 MHz)	4.15	NA	403.0125	48.0	46.7	CW	E	1.020	PB	2	0.339	0.422	0.202	0.5	0.327	0.164	0.168
Trunk	HAE6022A, 1/2 Wave (403-527 MHz)	4.15	NA	406.1250	48.0	46.6	CW	E	1.030	PB	2	0.331	0.637	0.137	0.5	0.379	0.190	0.195
Trunk	HAE6022A, 1/2 Wave (403-527 MHz)	4.15	NA	419.9875	48.0	46.8	CW	E	1.040	PB	2	0.384	0.522	0.274	0.5	0.409	0.205	0.210
Trunk	HAE6022A, 1/2 Wave (403-527 MHz)	4.15	NA	436.5000	48.0	47.0	CW	E	1.050	PB	2	0.672	0.223	0.435	0.5	0.466	0.233	0.238
Trunk	HAE6022A, 1/2 Wave (403-527 MHz)	4.15	NA	453.0125	48.0	47.5	CW	E	1.060	PB	2	0.928	0.354	0.234	0.5	0.536	0.268	0.271
Trunk	HAE6022A, 1/2 Wave (403-527 MHz)	4.15	NA	469.9875	48.0	47.7	CW	E	1.080	PB	2	0.822	0.251	0.352	0.5	0.513	0.257	0.258

MPE calculations are defined in section 15.0.

Table D.2 (Continued)
MPE measurement data for Passenger

D.U.T. Info.								Probe Info.			⁽⁶⁾ Meas. Unit			DUT Max. TX Factor	Avg. over Body (mW/cm ²)	Calc. P.D. (mW/cm ²)	Max Calc. P.D. (mW/cm ²)		
⁽²⁾ Ant Loc.	Ant. Model/ Desc.	Ant. Gain (dBi)	Ant. Meas. Dist. (cm)	Tx Freq (MHz)	⁽³⁾ Max Pwr (W)	Initial Pwr (W)	Test Mode	E/H Field	⁽⁴⁾ Probe Cal. Factor		⁽⁵⁾ Test Pos.	MPE Measurements							
													Head/ Top 1/3					Chest/ Middle 1/3	Lower Trunk/ Bottom 1/3
Trunk	HAE6029A, 1/2 Wave (403-527 MHz)	4.15	NA	403.0125	48.0	46.7	CW	E	1.020	PB	2	0.400	0.353	0.206	0.5	0.326	0.163	0.168	
Trunk	HAE6029A, 1/2 Wave (403-527 MHz)	4.15	NA	406.1250	48.0	46.6	CW	E	1.030	PB	2	0.377	0.562	0.304	0.5	0.427	0.213	0.220	
Trunk	HAE6029A, 1/2 Wave (403-527 MHz)	4.15	NA	419.9875	48.0	46.8	CW	E	1.040	PB	2	0.459	0.559	0.439	0.5	0.505	0.253	0.259	
Trunk	HAE6029A, 1/2 Wave (403-527 MHz)	4.15	NA	436.5000	48.0	47.0	CW	E	1.050	PB	2	0.751	0.221	0.483	0.5	0.509	0.255	0.260	
Trunk	HAE6029A, 1/2 Wave (403-527 MHz)	4.15	NA	453.0125	48.0	47.5	CW	E	1.060	PB	2	0.469	0.322	0.403	0.5	0.422	0.211	0.213	
Trunk	HAE6029A, 1/2 Wave (403-527 MHz)	4.15	NA	469.9875	48.0	47.7	CW	E	1.080	PB	2	0.789	0.261	0.413	0.5	0.527	0.263	0.265	
Trunk	PMAE4040A, 1/4 Wave (406-420 MHz)	4.65	NA	406.1250	48.0	46.6	CW	E	1.030	PB	2	0.363	0.637	0.242	0.5	0.426	0.213	0.220	
Trunk	PMAE4040A, 1/4 Wave (406-420 MHz)	4.65	NA	413.0125	48.0	47.2	CW	E	1.030	PB	2	0.316	0.667	0.255	0.5	0.425	0.213	0.216	
Trunk	PMAE4040A, 1/4 Wave (406-420 MHz)	4.65	NA	419.9875	48.0	46.8	CW	E	1.040	PB	2	0.382	0.592	0.469	0.5	0.500	0.250	0.257	
Trunk	PMAE4042A, 5/8 Wave (450-470 MHz)	5.65	NA	450.0125	48.0	47.4	CW	E	1.060	PB	2	0.585	0.286	0.337	0.5	0.427	0.213	0.216	
Trunk	PMAE4042A, 5/8 Wave (450-470 MHz)	5.65	NA	460.0125	48.0	47.6	CW	E	1.070	PB	2	0.583	0.238	0.235	0.5	0.377	0.188	0.190	
Trunk	PMAE4042A, 5/8 Wave (450-470 MHz)	5.65	NA	469.9875	48.0	47.7	CW	E	1.080	PB	2	0.640	0.181	0.346	0.5	0.420	0.210	0.211	

MPE calculations are defined in section 15.0.

Table D.2 (Continued)
MPE measurement data for Passenger

⁽²⁾ Ant Loc.	D.U.T. Info.							Probe Info.			⁽⁵⁾ Test Pos.	⁽⁶⁾ Meas. Unit			DUT Max. TX Factor	Avg. over Body (mW/cm ²)	Calc. P.D. (mW/cm ²)	Max Calc. P.D. (mW/cm ²)
	Ant. Model/ Desc.	Ant. Gain (dBi)	Ant. Meas. Dist. (cm)	Tx Freq (MHz)	⁽³⁾ Max Pwr (W)	Initial Pwr (W)	Test Mode	E/H Field	⁽⁴⁾ Probe Cal. Factor	MPE Measurements								
												Head/ Top 1/3	Chest/ Middle 1/3	Lower Trunk/ Bottom 1/3				
Trunk	PMAE4043A, 5/8 Wave (450-470 MHz)	7.15	NA	450.0125	48.0	47.4	CW	E	1.060	PB	2	0.333	0.244	0.215	0.5	0.280	0.140	0.142
Trunk	PMAE4043A, 5/8 Wave (450-470 MHz)	7.15	NA	460.0125	48.0	47.6	CW	E	1.070	PB	2	0.417	0.264	0.275	0.5	0.341	0.170	0.172
Trunk	PMAE4043A, 5/8 Wave (450-470 MHz)	7.15	NA	469.9875	48.0	47.7	CW	E	1.080	PB	2	0.564	0.187	0.208	0.5	0.345	0.173	0.174
Trunk	RAE4004ARB 5/8 Wave (445-470 MHz)	7.15	NA	445.0125	48.0	47.1	CW	E	1.060	PB	2	0.139	0.018	0.059	0.5	0.076	0.038	0.039
Trunk	RAE4004ARB 5/8 Wave (445-470 MHz)	7.15	NA	450.0125	48.0	47.4	CW	E	1.060	PB	2	0.179	0.045	0.115	0.5	0.120	0.060	0.061
Trunk	RAE4004ARB 5/8 Wave (445-470 MHz)	7.15	NA	457.5000	48.0	47.6	CW	E	1.070	PB	2	0.291	0.098	0.146	0.5	0.191	0.095	0.096
Trunk	RAE4004ARB 5/8 Wave (445-470 MHz)	7.15	NA	460.0125	48.0	47.6	CW	E	1.070	PB	2	0.341	0.090	0.139	0.5	0.203	0.102	0.103
Trunk	RAE4004ARB 5/8 Wave (445-470 MHz)	7.15	NA	469.9875	48.0	47.7	CW	E	1.080	PB	2	0.446	0.095	0.140	0.5	0.245	0.123	0.123

MPE calculations are defined in section 15.0.

Table D.2 (Continued)
MPE measurement data for Passenger

D.U.T. Info.										Probe Info.		⁽⁶⁾ Meas. Unit			DUT Max. TX Factor	Avg. over Body (mW/cm ²)	Calc. P.D. (mW/cm ²)	Max Calc. P.D. (mW/cm ²)
⁽²⁾ Ant Loc.	Ant. Model/ Desc.	Ant. Gain (dBi)	Ant. Meas. Dist. (cm)	Tx Freq (MHz)	⁽³⁾ Max Pwr (W)	Initial Pwr (W)	Test Mode	E/H Field	⁽⁴⁾ Probe Cal. Factor	⁽⁵⁾ Test Pos.	MPE Measurements							
												Head/ Top 1/3	Chest/ Middle 1/3	Lower Trunk/ Bottom 1/3				
Roof	HAE4002A, 1/4 Wave (403-430 MHz)	2.15	NA	403.0125	48.0	46.7	CW	E	1.020	PF	2	0.109	0.088	0.066	0.5	0.089	0.045	0.046
Roof	HAE4002A, 1/4 Wave (403-430 MHz)	2.15	NA	406.1250	48.0	46.6	CW	E	1.030	PF	2	0.117	0.107	0.075	0.5	0.103	0.051	0.053
Roof	HAE4002A, 1/4 Wave (403-430 MHz)	2.15	NA	416.5000	48.0	47.0	CW	E	1.030	PF	2	0.103	0.097	0.068	0.5	0.092	0.046	0.047
Roof	HAE4002A, 1/4 Wave (403-430 MHz)	2.15	NA	429.9875	48.0	47.1	CW	E	1.040	PF	3	0.058	0.041	0.026	0.5	0.078	0.039	0.040
Roof	HAE4003A, 1/4 Wave (450-470 MHz)	2.15	NA	450.0125	48.0	47.4	CW	E	1.060	PF	2	0.031	0.056	0.081	0.5	0.059	0.030	0.030
Roof	HAE4003A, 1/4 Wave (450-470 MHz)	2.15	NA	460.0125	48.0	47.6	CW	E	1.070	PF	2	0.010	0.039	0.080	0.5	0.046	0.023	0.023
Roof	HAE4003A, 1/4 Wave (450-470 MHz)	2.15	NA	469.9875	48.0	47.7	CW	E	1.080	PF	2	0.030	0.030	0.070	0.5	0.047	0.023	0.024
Roof	HAE4010A, 5/8 Wave (406-420 MHz)	5.65	NA	406.1250	48.0	46.6	CW	E	1.030	PF	2	0.012	0.007	0.006	0.5	0.009	0.004	0.004
Roof	HAE4010A, 5/8 Wave (406-420 MHz)	5.65	NA	413.0125	48.0	47.2	CW	E	1.030	PF	2	0.015	0.004	0.005	0.5	0.008	0.004	0.004
Roof	HAE4010A, 5/8 Wave (406-420 MHz)	5.65	NA	419.9875	48.0	46.8	CW	E	1.040	PF	2	0.010	0.006	0.006	0.5	0.008	0.004	0.004
Roof	HAE4011A, 1/2 Wave (450-470 MHz)	5.65	NA	450.0125	48.0	47.4	CW	E	1.060	PF	2	0.008	0.024	0.019	0.5	0.018	0.009	0.009
Roof	HAE4011A, 1/2 Wave (450-470 MHz)	5.65	NA	460.0125	48.0	47.6	CW	E	1.070	PF	2	0.006	0.017	0.018	0.5	0.015	0.007	0.007
Roof	HAE4011A, 1/2 Wave (450-470 MHz)	5.65	NA	469.9875	48.0	47.7	CW	E	1.080	PF	2	0.006	0.012	0.021	0.5	0.014	0.007	0.007

MPE calculations are defined in section 15.0.

Table D.2 (Continued)
MPE measurement data for Passenger

(2) Ant Loc.	D.U.T. Info.							Probe Info.		(5) Test Pos.	MPE Measurements	(6) Meas. Unit			DUT Max. TX Factor	Avg. over Body (mW/cm2)	Calc. P.D. (mW/cm2)	Max Calc. P.D. (mW/cm2)
	Ant. Model/ Desc.	Ant. Gain (dBi)	Ant. Meas. Dist. (cm)	Tx Freq (MHz)	(3) Max Pwr (W)	Initial Pwr (W)	Test Mode	E/H Field	(4) Probe Cal. Factor			Head/ Top 1/3	Chest/ Middle 1/3	Lower Trunk/ Bottom 1/3				
Roof	HAE6022A, 1/2 Wave (403-527 MHz)	4.15	NA	403.0125	48.0	46.7	CW	E	1.020	PF	2	0.139	0.069	0.093	0.5	0.102	0.051	0.053
Roof	HAE6022A, 1/2 Wave (403-527 MHz)	4.15	NA	406.1250	48.0	46.6	CW	E	1.030	PF	2	0.175	0.081	0.081	0.5	0.116	0.058	0.060
Roof	HAE6022A, 1/2 Wave (403-527 MHz)	4.15	NA	419.9875	48.0	46.8	CW	E	1.040	PF	2	0.187	0.092	0.068	0.5	0.120	0.060	0.062
Roof	HAE6022A, 1/2 Wave (403-527 MHz)	4.15	NA	436.5000	48.0	47.0	CW	E	1.050	PF	2	0.046	0.030	0.052	0.5	0.045	0.022	0.023
Roof	HAE6022A, 1/2 Wave (403-527 MHz)	4.15	NA	453.0125	48.0	47.5	CW	E	1.060	PF	2	0.039	0.082	0.061	0.5	0.064	0.032	0.032
Roof	HAE6022A, 1/2 Wave (403-527 MHz)	4.15	NA	469.9875	48.0	47.7	CW	E	1.080	PF	2	0.049	0.074	0.041	0.5	0.059	0.030	0.030
Roof	HAE6029A, 1/2 Wave (403-527 MHz)	4.15	NA	403.0125	48.0	46.7	CW	E	1.020	PF	2	0.152	0.063	0.088	0.5	0.103	0.052	0.053
Roof	HAE6029A, 1/2 Wave (403-527 MHz)	4.15	NA	406.1250	48.0	46.6	CW	E	1.030	PF	2	0.188	0.088	0.094	0.5	0.127	0.064	0.065
Roof	HAE6029A, 1/2 Wave (403-527 MHz)	4.15	NA	419.9875	48.0	46.8	CW	E	1.040	PF	2	0.181	0.085	0.073	0.5	0.118	0.059	0.060
Roof	HAE6029A, 1/2 Wave (403-527 MHz)	4.15	NA	436.5000	48.0	47.0	CW	E	1.050	PF	2	0.058	0.025	0.049	0.5	0.046	0.023	0.024
Roof	HAE6029A, 1/2 Wave (403-527 MHz)	4.15	NA	453.0125	48.0	47.5	CW	E	1.060	PF	2	0.050	0.065	0.071	0.5	0.066	0.033	0.033
Roof	HAE6029A, 1/2 Wave (403-527 MHz)	4.15	NA	469.9875	48.0	47.7	CW	E	1.080	PF	2	0.030	0.050	0.113	0.5	0.069	0.035	0.035

MPE calculations are defined in section 15.0.

Table D.2 (Continued)
MPE measurement data for Passenger

⁽²⁾ Ant Loc.	D.U.T. Info.							Probe Info.			⁽⁵⁾ Test Pos.	⁽⁶⁾ Meas. Unit			DUT Max. TX Factor	Avg. over Body (mW/cm ²)	Calc. P.D. (mW/cm ²)	Max Calc. P.D. (mW/cm ²)
	Ant. Model/ Desc.	Ant. Gain (dBi)	Ant. Meas. Dist. (cm)	Tx Freq (MHz)	⁽³⁾ Max Pwr (W)	Initial Pwr (W)	Test Mode	E/H Field	⁽⁴⁾ Probe Cal. Factor	MPE Measurements								
												Head/ Top 1/3	Chest/ Middle 1/3	Lower Trunk/ Bottom 1/3				
Roof	PMAE4039A, 1/4 Wave (403-430 MHz)	2.15	NA	403.0125	48.0	46.7	CW	E	1.020	PF	2	0.019	0.015	0.012	0.5	0.016	0.008	0.008
Roof	PMAE4039A, 1/4 Wave (403-430 MHz)	2.15	NA	406.1250	48.0	46.6	CW	E	1.030	PF	2	0.019	0.018	0.012	0.5	0.017	0.008	0.009
Roof	PMAE4039A, 1/4 Wave (403-430 MHz)	2.15	NA	416.5000	48.0	47.0	CW	E	1.030	PF	2	0.060	0.031	0.021	0.5	0.038	0.019	0.020
Roof	PMAE4039A, 1/4 Wave (403-430 MHz)	3.15	NA	429.9875	48.0	47.1	CW	E	1.040	PF	2	0.036	0.026	0.023	0.5	0.029	0.015	0.015
Roof	PMAE4040A, 1/4 Wave (406-420 MHz)	4.65	NA	406.1250	48.0	46.6	CW	E	1.030	PF	2	0.108	0.076	0.067	0.5	0.086	0.043	0.044
Roof	PMAE4040A, 1/4 Wave (406-420 MHz)	4.65	NA	413.0125	48.0	47.2	CW	E	1.030	PF	2	0.159	0.070	0.070	0.5	0.103	0.051	0.052
Roof	PMAE4040A, 1/4 Wave (406-420 MHz)	4.65	NA	419.9875	48.0	46.8	CW	E	1.040	PF	2	0.137	0.079	0.064	0.5	0.097	0.049	0.050
Roof	PMAE4041A, 1/4 Wave (450-470 MHz)	2.15	NA	450.0125	48.0	47.4	CW	E	1.060	PF	2	0.004	0.005	0.007	0.5	0.006	0.003	0.003
Roof	PMAE4041A, 1/4 Wave (450-470 MHz)	2.15	NA	460.0125	48.0	47.6	CW	E	1.070	PF	2	0.003	0.006	0.012	0.5	0.007	0.004	0.004
Roof	PMAE4041A, 1/4 Wave (450-470 MHz)	2.15	NA	469.9875	48.0	47.7	CW	E	1.080	PF	2	0.004	0.005	0.015	0.5	0.009	0.004	0.004

MPE calculations are defined in section 15.0.

Table D.2 (Continued)

MPE measurement data for Passenger

D.U.T. Info.										Probe Info.		⁽⁶⁾ Meas. Unit			DUT Max. TX Factor	Avg. over Body (mW/cm ²)	Calc. P.D. (mW/cm ²)	Max Calc. P.D. (mW/cm ²)
⁽²⁾ Ant Loc.	Ant. Model/ Desc.	Ant. Gain (dBi)	Ant. Meas. Dist. (cm)	Tx Freq (MHz)	⁽³⁾ Max Pwr (W)	Initial Pwr (W)	Test Mode	E/H Field	⁽⁴⁾ Probe Cal. Factor	⁽⁵⁾ Test Pos.	MPE Measurements							
												Head/ Top 1/3	Chest/ Middle 1/3	Lower Trunk/ Bottom 1/3				
Roof	PMAE4042A, 5/8 Wave (450-470 MHz)	5.65	NA	450.0125	48.0	47.4	CW	E	1.060	PF	2	0.044	0.050	0.068	0.5	0.057	0.029	0.029
Roof	PMAE4042A, 5/8 Wave (450-470 MHz)	5.65	NA	460.0125	48.0	47.6	CW	E	1.070	PF	2	0.027	0.072	0.080	0.5	0.064	0.032	0.032
Roof	PMAE4042A, 5/8 Wave (450-470 MHz)	5.65	NA	469.9875	48.0	47.7	CW	E	1.080	PF	2	0.043	0.053	0.085	0.5	0.065	0.033	0.033
Roof	PMAE4043A, 5/8 Wave (450-470 MHz)	7.15	NA	450.0125	48.0	47.4	CW	E	1.060	PF	2	0.011	0.021	0.039	0.5	0.025	0.013	0.013
Roof	PMAE4043A, 5/8 Wave (450-470 MHz)	7.15	NA	460.0125	48.0	47.6	CW	E	1.070	PF	2	0.006	0.029	0.030	0.5	0.023	0.012	0.012
Roof	PMAE4043A, 5/8 Wave (450-470 MHz)	7.15	NA	469.9875	48.0	47.7	CW	E	1.080	PF	2	0.012	0.024	0.034	0.5	0.025	0.013	0.013
Roof	RAE4004ARB 5/8 Wave (445-470 MHz)	7.15	NA	445.0125	48.0	47.1	CW	E	1.060	PF	2	0.003	0.004	0.003	0.5	0.004	0.002	0.002
Roof	RAE4004ARB 5/8 Wave (445-470 MHz)	7.15	NA	450.0125	48.0	47.4	CW	E	1.060	PF	2	0.003	0.006	0.006	0.5	0.005	0.003	0.003
Roof	RAE4004ARB 5/8 Wave (445-470 MHz)	7.15	NA	457.5000	48.0	47.6	CW	E	1.070	PF	2	0.004	0.022	0.013	0.5	0.014	0.007	0.007
Roof	RAE4004ARB 5/8 Wave (445-470 MHz)	7.15	NA	460.0125	48.0	47.6	CW	E	1.070	PF	2	0.004	0.017	0.010	0.5	0.011	0.006	0.006
Roof	RAE4004ARB 5/8 Wave (445-470 MHz)	7.15	NA	469.9875	48.0	47.7	CW	E	1.080	PF	2	0.006	0.016	0.014	0.5	0.013	0.006	0.007

MPE calculations are defined in section 15.0.

Table D.2 (Continued)

MPE measurement data for Passenger

D.U.T. Info.										Probe Info.		⁽⁶⁾ Meas. Unit			DUT Max. TX Factor	Avg. over Body (mW/cm ²)	Calc. P.D. (mW/cm ²)	Max Calc. P.D. (mW/cm ²)
⁽²⁾ Ant Loc.	Ant. Model/ Desc.	Ant. Gain (dBi)	Ant. Meas. Dist. (cm)	Tx Freq (MHz)	⁽³⁾ Max Pwr (W)	Initial Pwr (W)	Test Mode	E/H Field	⁽⁴⁾ Probe Cal. Factor	⁽⁵⁾ Test Pos.	MPE Measurements							
												Head/ Top 1/3	Chest/ Middle 1/3	Lower Trunk/ Bottom 1/3				
Trunk	HAE4010A, 5/8 Wave (406-420 MHz)	5.65	NA	406.1250	48.0	46.6	CW	E	1.030	PF	2	0.091	0.062	0.019	0.5	0.059	0.030	0.030
Trunk	HAE4010A, 5/8 Wave (406-420 MHz)	5.65	NA	413.0125	48.0	47.2	CW	E	1.030	PF	2	0.086	0.064	0.020	0.5	0.058	0.029	0.030
Trunk	HAE4010A, 5/8 Wave (406-420 MHz)	5.65	NA	419.9875	48.0	46.8	CW	E	1.040	PF	2	0.038	0.028	0.016	0.5	0.028	0.014	0.015
Trunk	HAE4011A, 1/2 Wave (450-470 MHz)	5.65	NA	450.0125	48.0	47.4	CW	E	1.060	PF	2	0.116	0.093	0.153	0.5	0.128	0.064	0.065
Trunk	HAE4011A, 1/2 Wave (450-470 MHz)	5.65	NA	460.0125	48.0	47.6	CW	E	1.070	PF	2	0.121	0.106	0.078	0.5	0.109	0.054	0.055
Trunk	HAE4011A, 1/2 Wave (450-470 MHz)	5.65	NA	469.9875	48.0	47.7	CW	E	1.080	PF	2	0.085	0.071	0.045	0.5	0.072	0.036	0.036
Trunk	HAE6022A, 1/2 Wave (403-527 MHz)	4.15	NA	403.0125	48.0	46.7	CW	E	1.020	PF	2	0.170	0.138	0.133	0.5	0.150	0.075	0.077
Trunk	HAE6022A, 1/2 Wave (403-527 MHz)	4.15	NA	406.1250	48.0	46.6	CW	E	1.030	PF	2	0.180	0.126	0.103	0.5	0.140	0.070	0.072
Trunk	HAE6022A, 1/2 Wave (403-527 MHz)	4.15	NA	419.9875	48.0	46.8	CW	E	1.040	PF	2	0.160	0.155	0.089	0.5	0.140	0.070	0.072
Trunk	HAE6022A, 1/2 Wave (403-527 MHz)	4.15	NA	436.5000	48.0	47.0	CW	E	1.050	PF	2	0.248	0.133	0.130	0.5	0.179	0.089	0.091
Trunk	HAE6022A, 1/2 Wave (403-527 MHz)	4.15	NA	453.0125	48.0	47.5	CW	E	1.060	PF	2	0.380	0.153	0.326	0.5	0.304	0.152	0.153
Trunk	HAE6022A, 1/2 Wave (403-527 MHz)	4.15	NA	469.9875	48.0	47.7	CW	E	1.080	PF	2	0.233	0.160	0.185	0.5	0.208	0.104	0.105

MPE calculations are defined in section 15.0.

Table D.2 (Continued)
MPE measurement data for Passenger

D.U.T. Info.								Probe Info.			⁽⁶⁾ Meas. Unit			DUT Max. TX Factor	Avg. over Body (mW/cm ²)	Calc. P.D. (mW/cm ²)	Max Calc. P.D. (mW/cm ²)		
⁽²⁾ Ant Loc.	Ant. Model/ Desc.	Ant. Gain (dBi)	Ant. Meas. Dist. (cm)	Tx Freq (MHz)	⁽³⁾ Max Pwr (W)	Initial Pwr (W)	Test Mode	E/H Field	⁽⁴⁾ Probe Cal. Factor		⁽⁵⁾ Test Pos.	MPE Measurements							
													Head/ Top 1/3					Chest/ Middle 1/3	Lower Trunk/ Bottom 1/3
Trunk	HAE6029A, 1/2 Wave (403-527 MHz)	4.15	NA	403.0125	48.0	46.7	CW	E	1.020	PF	2	0.175	0.138	0.193	0.5	0.172	0.086	0.088	
Trunk	HAE6029A, 1/2 Wave (403-527 MHz)	4.15	NA	406.1250	48.0	46.6	CW	E	1.030	PF	2	0.168	0.143	0.147	0.5	0.157	0.079	0.081	
Trunk	HAE6029A, 1/2 Wave (403-527 MHz)	4.15	NA	419.9875	48.0	46.8	CW	E	1.040	PF	2	0.193	0.118	0.098	0.5	0.142	0.071	0.073	
Trunk	HAE6029A, 1/2 Wave (403-527 MHz)	4.15	NA	436.5000	48.0	47.0	CW	E	1.050	PF	2	0.225	0.103	0.143	0.5	0.165	0.082	0.084	
Trunk	HAE6029A, 1/2 Wave (403-527 MHz)	4.15	NA	453.0125	48.0	47.5	CW	E	1.060	PF	2	0.372	0.160	0.393	0.5	0.327	0.163	0.165	
Trunk	HAE6029A, 1/2 Wave (403-527 MHz)	4.15	NA	469.9875	48.0	47.7	CW	E	1.080	PF	2	0.259	0.138	0.202	0.5	0.216	0.108	0.108	
Trunk	PMAE4040A, 1/4 Wave (406-420 MHz)	4.65	NA	406.1250	48.0	46.6	CW	E	1.030	PF	2	0.126	0.130	0.116	0.5	0.128	0.064	0.066	
Trunk	PMAE4040A, 1/4 Wave (406-420 MHz)	4.65	NA	413.0125	48.0	47.2	CW	E	1.030	PF	2	0.194	0.177	0.082	0.5	0.156	0.078	0.079	
Trunk	PMAE4040A, 1/4 Wave (406-420 MHz)	4.65	NA	419.9875	48.0	46.8	CW	E	1.040	PF	2	0.187	0.110	0.081	0.5	0.131	0.066	0.067	
Trunk	PMAE4042A, 5/8 Wave (450-470 MHz)	5.65	NA	450.0125	48.0	47.4	CW	E	1.060	PF	2	0.321	0.153	0.302	0.5	0.274	0.137	0.139	
Trunk	PMAE4042A, 5/8 Wave (450-470 MHz)	5.65	NA	460.0125	48.0	47.6	CW	E	1.070	PF	2	0.192	0.119	0.258	0.5	0.203	0.101	0.102	
Trunk	PMAE4042A, 5/8 Wave (450-470 MHz)	5.65	NA	469.9875	48.0	47.7	CW	E	1.080	PF	2	0.250	0.160	0.159	0.5	0.205	0.102	0.103	

MPE calculations are defined in section 15.0.

Table D.2 (Continued)
MPE measurement data for Passenger

D.U.T. Info.								Probe Info.			⁽⁶⁾ Meas. Unit			DUT Max. TX Factor	Avg. over Body (mW/cm ²)	Calc. P.D. (mW/cm ²)	Max Calc. P.D. (mW/cm ²)	
⁽²⁾ Ant Loc.	Ant. Model/ Desc.	Ant. Gain (dBi)	Ant. Meas. Dist. (cm)	Tx Freq (MHz)	⁽³⁾ Max Pwr (W)	Initial Pwr (W)	Test Mode	E/H Field	⁽⁴⁾ Probe Cal. Factor	⁽⁵⁾ Test Pos.	MPE Measurements							
												Head/ Top 1/3	Chest/ Middle 1/3					Lower Trunk/ Bottom 1/3
Trunk	PMAE4043A, 5/8 Wave (450-470 MHz)	7.15	NA	450.0125	48.0	47.4	CW	E	1.060	PF	2	0.256	0.159	0.198	0.5	0.217	0.108	0.110
Trunk	PMAE4043A, 5/8 Wave (450-470 MHz)	7.15	NA	460.0125	48.0	47.6	CW	E	1.070	PF	2	0.213	0.116	0.160	0.5	0.174	0.087	0.088
Trunk	PMAE4043A, 5/8 Wave (450-470 MHz)	7.15	NA	469.9875	48.0	47.7	CW	E	1.080	PF	2	0.225	0.165	0.118	0.5	0.183	0.091	0.092
Trunk	RAE4004ARB 5/8 Wave (445-470 MHz)	7.15	NA	445.0125	48.0	47.1	CW	E	1.060	PF	2	0.049	0.019	0.053	0.5	0.043	0.021	0.022
Trunk	RAE4004ARB 5/8 Wave (445-470 MHz)	7.15	NA	450.0125	48.0	47.4	CW	E	1.060	PF	2	0.081	0.065	0.070	0.5	0.076	0.038	0.039
Trunk	RAE4004ARB 5/8 Wave (445-470 MHz)	7.15	NA	457.5000	48.0	47.6	CW	E	1.070	PF	2	0.106	0.047	0.096	0.5	0.089	0.044	0.045
Trunk	RAE4004ARB 5/8 Wave (445-470 MHz)	7.15	NA	460.0125	48.0	47.6	CW	E	1.070	PF	2	0.089	0.054	0.075	0.5	0.078	0.039	0.039
Trunk	RAE4004ARB 5/8 Wave (445-470 MHz)	7.15	NA	469.9875	48.0	47.7	CW	E	1.080	PF	2	0.061	0.047	0.053	0.5	0.058	0.029	0.029

MPE calculations are defined in section 15.0.

Table D.3
LMR UHF MPE Results for FCC

Note:
Blue fonts: Frequencies not regulated by FCC.

Test Pos	Angle	Trunk/ Roof	E/H Field	Antenna no.	P initial (W)													
					f1	f2	f3	f4	f5	f6	f7	f8	f9	f10	f11	f12	f13	
Pmax (W) 48					46.7	46.6	47.2	47	46.8	47.1	47	47.1	47.4	47.5	47.6	47.7		
FCC Limit (mW/cm ²)					0.3	0.3	0.3	0.3	0.3	0.3	0.3	0.3	0.3	0.3	0.3	0.3	0.3	0.3
					403.0125	406.1250	413.0125	416.5000	419.9875	429.9875	436.5000	445.0125	450.0125	453.0125	457.5000	460.0125	469.9875	
BS	0	Roof	E	1	0.076	0.073		0.08		0.081								
BS	0	Roof	E	2									0.079			0.094	0.08	
BS	0	Roof	E	3		0.044	0.041		0.027									
BS	0	Roof	E	4									0.065			0.05	0.03	
BS	0	Roof	E	5	0.086	0.079			0.088		0.083			0.08				
BS	0	Roof	E	6	0.083	0.077			0.087		0.083			0.08				
BS	0	Roof	E	7	0.013	0.012		0.026		0.043								
BS	0	Roof	E	8		0.065	0.077		0.081									
BS	0	Roof	E	9									0.016			0.023	0.037	
BS	0	Roof	E	10									0.068			0.085	0.085	
BS	0	Roof	E	11									0.079			0.087	0.075	
BS	0	Roof	E	12								0.051	0.06		0.072	0.066	0.059	
BS	0	Trunk	E	3		0.083	0.065		0.041									
BS	0	Trunk	E	4									0.111			0.074	0.041	
BS	0	Trunk	E	5	0.12	0.111			0.099		0.087			0.129				
BS	0	Trunk	E	6	0.118	0.115			0.1		0.082			0.121				
BS	0	Trunk	E	8		0.093	0.097		0.093									
BS	0	Trunk	E	10									0.135			0.132	0.126	
BS	0	Trunk	E	11									0.149			0.137	0.112	
BS	45	Trunk	E	11									0.122					
BS	90	Trunk	E	11									0.112					
BS	0	Trunk	E	12								0.107	0.112		0.123	0.11	0.103	
PB	0	Roof	E	1	0.046	0.043		0.034		0.04								
PB	0	Roof	E	2									0.06			0.051	0.041	
PB	0	Roof	E	3		0.002	0.003		0.002									
PB	0	Roof	E	4									0.016			0.006	0.006	
PB	0	Roof	E	5	0.047	0.04			0.033		0.036			0.048			0.033	
PB	0	Roof	E	6	0.034	0.039			0.027		0.026			0.046			0.043	
PB	0	Roof	E	7	0.007	0.005		0.009		0.012								
PB	0	Roof	E	8		0.035	0.035		0.023									
PB	0	Roof	E	9									0.004			0.006	0.006	
PB	0	Roof	E	10									0.048			0.05	0.042	
PB	0	Roof	E	11									0.021			0.017	0.016	
PB	0	Roof	E	12								0.005	0.006		0.01	0.008	0.007	
PB	0	Trunk	E	3		0.074	0.045		0.032									
PB	0	Trunk	E	4									0.152			0.115	0.074	
PB	0	Trunk	E	5	0.168	0.195			0.21		0.238			0.271			0.258	
PB	0	Trunk	E	6	0.168	0.22			0.259		0.26			0.213			0.265	
PB	0	Trunk	E	8		0.22	0.216		0.257									
PB	0	Trunk	E	10									0.216			0.19	0.211	
PB	0	Trunk	E	11									0.142			0.172	0.174	
PB	0	Trunk	E	12								0.039	0.061		0.096	0.103	0.123	
PF	0	Roof	E	1	0.046	0.053		0.047		0.04								
PF	0	Roof	E	2									0.03			0.023	0.024	
PF	0	Roof	E	3		0.004	0.004		0.004									
PF	0	Roof	E	4									0.009			0.007	0.007	
PF	0	Roof	E	5	0.053	0.06			0.062		0.023			0.032			0.03	
PF	0	Roof	E	6	0.053	0.065			0.06		0.024			0.033			0.035	
PF	0	Roof	E	7	0.008	0.009		0.02		0.015								
PF	0	Roof	E	8		0.044	0.052		0.05									
PF	0	Roof	E	9									0.003			0.004	0.004	
PF	0	Roof	E	10									0.029			0.032	0.033	
PF	0	Roof	E	11									0.013			0.012	0.013	
PF	0	Roof	E	12								0.002	0.003		0.007	0.006	0.007	
PF	0	Trunk	E	3		0.03	0.03		0.015									
PF	0	Trunk	E	4									0.065			0.055	0.036	
PF	0	Trunk	E	5	0.077	0.072			0.072		0.091			0.153			0.105	
PF	0	Trunk	E	6	0.088	0.081			0.073		0.084			0.165			0.108	
PF	0	Trunk	E	8		0.066	0.079		0.067									
PF	0	Trunk	E	10									0.139			0.102	0.103	
PF	0	Trunk	E	11									0.11			0.088	0.092	
PF	0	Trunk	E	12								0.022	0.039		0.045	0.039	0.029	