



CERTIFICATE 2518.05

DECLARATION OF COMPLIANCE: MPE ASSESSMENT Part 1 of 2

**Motorola Solutions Inc.
EME Test Laboratory**

Motorola Solutions Malaysia Sdn Bhd
Plot 2A, Medan Bayan Lepas,
Mukim 12 SWD 11900 Bayan Lepas Penang, Malaysia.

Date of Report: 4/13/2020
Report Revision: A

Responsible Engineer: Goh Jue Yie (EME Engineer)
Report author: Goh Jue Yie (EME Engineer)
Date(s) Tested: 3/8/2017-3/20/2017; 3/25/2020 - 3/27/2020
Manufacturer: Futurecom Systems Group (DVR), Motorola Solutions. Inc (Mobile)
Date submitted for test: 01/13/2017; 03/25/2020
DUT Description: **APX6500 VHF:** Multiple HW Encryption WiFi Interoperability Data Modem Tethering via WiFi or Cable
Companion Device: DVR 800 (806-824 MHz; 851-869MHz), Digital Vehicular Repeater
Test TX mode(s): CW
Max. Power output: **APX6500 VHF:** 60W (136-174 MHz); 11.2 mW (Bluetooth); 6.3 mW (Bluetooth LE);
(WLAN 2.4GHz 802.11b), 15.8 mW (WLAN 2.4GHz 802.11g), 12.6mW (WLAN 2.4GHz 802.11n);
15.8mW (WLAN 5GHz 802.11a/n/ac)
Companion Device: 10W (DVR 800)
TX Frequency Bands: **APX6500 VHF:** 136-174 MHz; WLAN 2412-2462 MHz; WLAN 5180-5825 MHz; BT 2402-2480 MHz
Companion Device: 806-825 MHz; 851-870MHz
Signaling type: FM, TDMA, FHSS (Bluetooth), 802.11b/g/n (WLAN 2.4 GHz), 802.11 a/n/ac (WLAN 5 GHz)
Model(s) Tested: **APX6500 VHF:** M25KSS9PW1BN (PMUD3490A)
Companion Device: MOBEXCOM DVRS 800 (DQPM DVRS8000P)
Model(s) Certified: M22KSS9PW1BN (PMUD3490A), M24KSS9PW1BN (PMUD3490A),
M25KSS9PW1BN (PMUD3490A), M36KSS9PW1BN (PMUD3490A),
MOBEXCOM DVRS 800 (DQPM DVRS8000P)
Serial Number(s): 471TWD5463 (APX6500 VHF) , 17010530 (DVR 800)
Classification: Occupational/Controlled Environment
Applicant Name: Motorola Solutions Inc.
Applicant Address: 8000 West Sunrise Boulevard, Fort Lauderdale, Florida 33322
FCC ID: **APX6500 VHF:** AZ492FT7130 (150.8-173.4 MHz, 2402-2480 MHz, 2412-2462 MHz; 5180-5825 MHz)
Companion Device: LO6-DVRS800 (806-824 MHz; 851-869MHz)
This report contains results that are immaterial for FCC equipment approval, which are clearly identified.
IC: **APX6500 VHF:** 109U-92FT7130
Companion Device: 2098B-DVRS800
This report contains results that are immaterial for ISED Canada equipment approval, which are clearly identified.

The MPE results clearly demonstrate compliance with FCC Occupational/Controlled RF Exposure limits. FCC rules require compliance for Passengers and Bystanders to the FCC General Population/Uncontrolled limits.

Based on the information and the testing results provided herein, the undersigned certifies that when used as stated in the operating instructions supplied, said product complies with the national and international reference standards and guidelines listed in section 4.0 of this report (no deviation from standard methods). This report shall not be reproduced without written approval from an officially designated representative of the Motorola Solutions Inc. EME Laboratory.

I attest to the accuracy of the data and assume full responsibility for the completeness of these measurements.
This reporting format is consistent with the suggested guidelines of the TIA TSB-159 April 2006
The results and statements contained in this report pertain only to the device(s) evaluated herein.

Tiong Nguk Ing
Deputy Technical Manager (Approved Signatory)
Approval Date: 4/24/2020

Document Revision History

Date	Revision	Comments
4/13/2020	A	Initial release

Table of Contents

Part 1 of 2

1.0 Introduction..... 5

2.0 FCC MPE Summary 5

3.0 Abbreviations / Definitions..... 5

4.0 Referenced Standards and Guidelines 6

5.0 Power Density Limits 6

6.0 N_c Test Channels..... 8

7.0 Measurement Equipment 8

8.0 Measurement System Uncertainty Levels 8

9.0 Product and System Description..... 9

10.0 Additional Options and Accessories..... 10

11.0 Test Set-Up Description..... 10

12.0 Method of Measurement for DVR with trunk mounted antenna(s)..... 11

 12.1 External/Bystander vehicle MPE measurements 11

 12.2 Internal/Passenger vehicle MPE measurements..... 11

13.0 Method of Measurement APX6500 VHF Mobile radio with roof mounted antenna(s)..... 12

 13.1 External/Bystander vehicle MPE measurements 12

 13.2 Internal/Passenger vehicle MPE measurements..... 12

14.0 MPE Variability Requirement for External/Bystander vehicle MPE measurement..... 13

15.0 MPE Calculations 13

16.0 Antenna Summary 14

17.0 Test Results Summary 15

 17.1 MPE Test Results Summary for APX6500 VHF Mobile radio and DVR 800 15

 17.2 MPE Test Results for Bluetooth and WLAN..... 16

 17.3 Simultaneous Transmission..... 17

18.0 Conclusion 19

19.0 User Instructions Considerations 24

Appendix A - Antenna Locations, Test Distances, and Cable Losses..... 25

Appendix B - Probe Calibration Certificates 32

Appendix C - Photos of Assessed Antennas..... 38

Part 2 of 2

Appendices

Appendix D – MPE Test Results Summary for APX6500 VHF 2
Appendix E – MPE Test Results Summary for Companion Device (DVR 800) 19
Appendix F – MPE Measurement Results for APX6500 VHF 24
Appendix G – MPE Measurement Results for Companion Device (DVR 800) 45

1.0 Introduction

This report details the test setup, test equipment and test results of Maximum Permissible Exposure (MPE) performed at Motorola Solutions’ outside test site for APX6500 VHF M25KSS9PW1BN (FCC ID: AZ492FT7130) and Companion Device DVR 800 (FCC ID: LO6-DVRS800).

2.0 FCC MPE Summary

Table 1

APX6500 VHF band (FCC ID: AZ492FT7130)					
Roof Mounted Antenna					
Equipment Class	Frequency Band (MHz)	Passenger		Bystander	
		Power Density (mw/cm²)	Highest % of Limit	Power Density (mw/cm²)	Highest % of Limit
TNB	150.8-173.4 MHz	0.230	114.6%	0.060	29.1%
DTS	WLAN (2412-2462)	0.018	1.77%	0.018	1.77%
NII	WLAN (5180 - 5825)	0.007	0.67%	0.007	0.67%
DSS	BT (2402-2480)	0.005	0.50%	0.005	0.50%
Companion Device DVR 800 (FCC ID: LO6-DVRS800)					
Trunk Mounted Antenna					
Equipment Class	Frequency Band (MHz)	Passenger		Bystander	
		Power Density (mw/cm²)	Highest % of Limit	Power Density (mw/cm²)	Highest % of Limit
TNB	806-824; 851-869	0.060	11.1%	0.028	4.9%
Simultaneous Transmissions					
Simultaneous Transmissions conditions		Passenger		Bystander	
		Highest Combine % of limit		Highest Combine % of limit	
APX6500 (VHF) + WLAN + DVR 800		127.5%		33.8%	

3.0 Abbreviations / Definitions

- CNR: Calibration Not Required
- CW: Continuous Wave
- DUT: Device Under Test
- EME: Electromagnetic Energy
- FM: Frequency Modulation
- MPE: Maximum Permissible Exposure
- GPS: Global Positioning System
- LMR: Land Mobile Radio
- SAR: Specific Absorption Rate
- NA: Not Applicable
- BS: Bystander
- PB: Passenger Back seat
- PF: Passenger Front seat
- PTT: Push to Talk

4.0 Referenced Standards and Guidelines

This product is designed to comply with the following applicable national and international standards and guidelines.

- United States Federal Communications Commission, Code of Federal Regulations; Rule Part 47CFR § 1.1310, § 2.1091 (d) and § 2.1093 for RF Exposure, where applicable.
- Federal Communications Commission, “Evaluating Compliance with FCC Guidelines for Human Exposure to Radio frequency Electromagnetic Fields”, OET Bulletin 65 (Edition 97-01), FCC, Washington, D.C.: August 1997.
- Institute of Electrical and Electronics Engineers (IEEE) C95.1-2019
- American National Standards Institute (ANSI) / Institute of Electrical and Electronics Engineers (IEEE) C95. 1-1992. Specific to FCC rules and regulations.
- Institute of Electrical and Electronics Engineers (IEEE) C95.3-2002
- International Commission on Non-Ionizing Radiation Protection (ICNIRP) 1998
- Ministry of Health (Canada) Safety Code 6 (2015), Limits of Human Exposure to Radio frequency Electromagnetic Fields in the Frequency Range from 3 kHz to 300 GHz
- RSS-102 (Issue 5) – Radio Frequency (RF) Exposure Compliance of Radio communication Apparatus (All Frequency Bands)
- FCC KDB – 447498 D01 General RF Exposure Guidance v06
- FCC KDB – 865664 D02 RF Exposure Reporting v01r02

5.0 Power Density Limits

Table 2 – Occupational / Controlled Exposure Limits

Frequency Range (MHz)	FCC OET Bulletin 65/ 47CFR § 1.1310	ICNIRP	IEEE C95.1 2019	RSS-102 Issue 5 2015
	mW/cm ²		W/m ²	W/m ²
10 – 20				10.0
20 – 48				$44.72 / f^{0.5}$
30 – 300	1.0			
48 – 100				6.455
10 – 400		10.0		
100 – 400			10.0	
100 – 6,000				$0.6455 f^{0.5}$
300 – 1,500	f/300			

Table 2 – Occupational / Controlled Exposure Limits (Con’t.)

Frequency Range (MHz)	FCC OET Bulletin 65/ 47CFR § 1.1310	ICNIRP	IEEE C95.1 2019	RSS-102 Issue 5 2015
	mW/cm ²		W/m ²	W/m ²
400 – 2,000		f/40	f/40	
1,500 – 100,000	5.0			
2,000 – 300,000		50.0	50.0	
6,000 – 15,000				50.0
15000 – 150,000				50.0
150000 – 300,000				$3.33 \times 10^{-4} f$

Table 3 – General Population / Uncontrolled Exposure Limits

Frequency Range (MHz)	FCC OET Bulletin 65/ 47CFR § 1.1310	ICNIRP	IEEE C95.1 2019	RSS-102 Issue 5 2015
	mW/cm ²		W/m ²	W/m ²
10 – 20				2.0
20 – 48				$8.944 / f^{0.5}$
30 – 300	0.2			
48 – 300				1.291
10 – 400		2.0		
100 – 300				
100 – 400			2.0	
300 – 1,500	f/1,500			
300 – 6000				$0.02619 f^{0.6834}$
400 – 2,000		f/200	f/200	
1,500 – 100,000	1.0			
2,000 – 300,000		10.0	10.0	
6,000 – 15,000				10.0
15,000 – 150,000				10.0
150,000 – 300,000				$6.67 \times 10^{-5} f$

6.0 N_c Test Channels

The number of test channels is determined by using Equation 1 below. This equation is available in FCC’s KDB 447498. The test channels are appropriately spaced across the antenna’s frequency range.

Equation 1 – Number of test channels

$$N_c = \text{Round} \{ [100(f_{\text{high}} - f_{\text{low}})/f_c]^{0.5} \times (f_c / 100)^{0.2} \}$$

where N_c is the number of test channels, f_{high} and f_{low} are the highest and lowest frequencies within the transmission band, f_c is the mid-band frequency, and frequencies are in MHz.

7.0 Measurement Equipment

Table 4 – Equipment

Equipment Type	Model #	SN	Calibration Date	Calibration Due Date
Automobile	Volvo 240-1988	NA	NA	NA
Survey Meter	ETS Model HI-2200	00206805	04/01/2019	04/01/2020
Probe – E-Field	ETS Model E100	00126277		
Probe – H-Field	ETS Model H200	00084225		

E-field measurements are in mW/cm².
 H field measurements are in A/m.

8.0 Measurement System Uncertainty Levels

Table 5 – Uncertainty Budget for Near Field Probe Measurements

	Tol. (± %)	Prob. Dist.	Divisor	u_i (±%)		v_i
Measurement System						
Probe Calibration	7.1	N	1.00	7.1	50.4	∞
Survey Meter Calibration	0.0	N	1.00	0.0	0.0	∞
Hemispherical Isotropy	8.0	R	1.73	4.6	21.33	∞
Linearity	5.0	R	1.73	2.9	8.33	∞
Pulse Response	1.0	R	1.73	0.6	0.33	∞
RF Ambient Noise	3.0	R	1.73	1.7	3.00	∞
RF Reflections	8.0	R	1.73	4.6	21.33	∞
Probe Positioning	10.0	R	1.73	5.8	33.333	∞
Test sample Related					0.00	
Antenna Positioning	3.0	N	1.00	3.0	9.0	∞
Power drift	5.0	R	1.73	2.9	8.33	∞
Bystander measurement uncertainty	4.8	N	1.00	4.8	23.04	∞
Passenger measurement uncertainty	8.1	N	1.00	8.1	65.61	∞
Combined Standard Uncertainty		RSS		15.6	15.6	∞
Expanded Uncertainty (95% CONFIDENCE LEVEL)		$k=2$		31	31	

9.0 Product and System Description

APX6500 VHF operates in the LMR bands using either frequency modulation (FM) with 100% transmit duty cycle or TDMA signals with maximum of 50% transmit duty cycle. For conservative assessment, FM signal was tested. A duty factor of 50% applies for PTT operation mode.

This device also incorporates a Class 1 Bluetooth device which is a Frequency Hopping Spread Spectrum (FHSS) technology. The Bluetooth radio modem is used to wireless link audio accessories. The maximum actual transmission duty cycle is imposed by the Bluetooth standard. The maximum duty cycle for BT is 100%. Bluetooth Low Energy (BT LE) intended to reduce power consumption.

This device also contains WLAN technology for data capabilities over 802.11b/g/n 2.4 GHz and 802.11 a/n/ac 5 GHz wireless networks.

MOBEXCOM DVR 800 is Digital Vehicular Repeater (DVR) manufactured by Futurecom System Group. At standalone the DVR operates at a maximum power up to 20W, but when the DVR is interfaced to the APX6500 VHF Mobile radio, the maximum power is 10W as listed in Table 6. For more detailed information refer to the Product Safety and RF Energy Exposure Booklet for DVR.

Table 6 below summarizes the technologies, bands, maximum duty cycles and maximum output powers. Maximum output powers are defined as upper limit of the production line final test station.

Table 6 – Bands, Duty Cycle and Maximum power

Technologies	Bands (MHz)	Duty Cycle (%)	Max Power (W)
APX6500 (VHF)	150.8 - 173.4 (VHF)	50 (PTT)	60
	BT 2402-2480	100	0.0112
	BT LE 2402-2480	100	0.0063
	WLAN 2400 – 2462 (802.11b/g/n)	100	0.0398 (802.11b)
			0.0158 (802.11g)
			0.0126 (802.11n)
WLAN 5180-5825 (802.11 a/n/ac)	100	0.0158	
DVR 800	806-824; 851-869	100	10

This test report covers the RF exposure performance of the APX6500 VHF (FCC ID: AZ492FT7130) interfaced with, and transmitting simultaneously with Companion device DVR 800 (FCC ID: LO6-DVRS800). DVR operate in repeater; transmit with duty cycle up to 100%. A duty factor of 50% applies for APX6500 VHF with PTT operating mode.

Table 7 lists the simultaneous transmission conditions.

Table 7 – Simultaneous transmission conditions

Simultaneous transmission conditions	APX6500 VHF	DVR 800
APX6500 VHF + DVR 800	x	x

Note: ' x ' Simultaneous transmitting antennas

This device will be marketed to and used by employees solely for work-related operations. User training is the responsibility of the organizations that employ the individuals using the occupational device. The Product Safety and RF Energy Exposure Booklet for Digital Vehicular Repeater Systems (DVRS) contains all the information necessary to inform the organization and its employees in safe usage and for creating training materials or conducting instructional sessions for those employees.

Accordingly this product is classified as Occupational/Controlled Exposure. However, in accordance with FCC requirements, the passengers inside the vehicle and the bystanders external to the vehicle are evaluated to the General Population/Uncontrolled Exposure Limits.

(Note that “Bystanders” as used herein are people other than operator)

10.0 Additional Options and Accessories

Not available.

11.0 Test Set-Up Description

Assessments were performed with APX6500 VHF Mobile radio and Companion device DVR 800 installed in the test vehicle, at the specified distances and test locations indicated in sections 12.0, 13.0 and Appendix A.

All antennas described in Table 8 were considered in order to develop the test plan for this product. Antennas were installed and tested per their appropriate mount locations (Roof / Trunk) and defined test channels. The DVR antenna mounted at center of the trunk (for external/bystander measurement) or toward the center of the trunk at a minimum 85 cm from backseat passenger (for Internal/passenger measurement), and the APX6500 VHF Mobile radio antennas are mounted at the center of the roof.

The system was tested using a low-loss 16’ Teflon RG58A/U cable attaching the radio to the transmit antenna. This cable is shorter and lower attenuation than the 17’ RG58A/U cables supplied in the customer kits for connecting the radio to the transmit antenna. The cable used in the test setup also has lower attenuation over the test frequency range than the cable provided in the customer kits. The use of a shorter cable with lower attenuation in the test setup ensures that the test data is more conservative with regards to the actual installation. Cable losses are

12.0 Method of Measurement for DVR with trunk mounted antenna(s)

12.1 External/Bystander vehicle MPE measurements

Initially the DVR antenna is located at the center of the trunk. Refer to Appendix A for antenna location and distance.

MPE measurements for bystander (BS) conditions are determined by taking the average of (10) measurements in a 2 m vertical line for each of the (5) bystander test locations indicated in Appendix A with 20 cm height increments, with the distance of 90cm from the test vehicle's body, as stated in the user manual. The measurement probe is positioned orthogonal to antenna (typically parallel to ground with a vertically mounted antenna) and aimed directly at the antenna's axis. These measurements are representative of persons other than the operator standing next to the vehicle.

12.2 Internal/Passenger vehicle MPE measurements

The DVR antenna is located toward the center of the trunk at a minimum 85 cm from backseat passenger. Refer to Appendix A for antenna location and distance.

MPE measurements for passenger front seat (PF) and backseat (PB) conditions are determined by taking the average of the (3) measurements (Head, Chest, and Lower Trunk) inside the vehicle for both the front and back seats.

The backseat is a bench seat and therefore each position (Head, Chest & Lower Trunk) were scanned across (horizontally) the seat starting from the middle of the seat to the edge of the seat stopping 20 cm from the vehicle door. Similar process was used in the front bucket seat.

The probe handle is oriented parallel (horizontal) to the ground and pointed towards the back of the vehicle. The probe handle is not oriented normal to the seat surface. The probe head (incorporating the field sensors) is scanned continuously (using the max-hold function available in the meter) along three test axes which are parallel to the seat angle (intended as the line determined by the intersection of the plane of the seat and the plane of the backrest) and are 20 cm from the seat surface. One test axis is at the Head height, another is at the Chest height, and another is at the Lower Trunk height. The maximum field level value recorded for each test axis is logged. The MPE is determined by averaging these three maximum values regardless of the geometrical location where they were observed. For instance, the locations of the three maxima may lie on different vertical (relative to ground) lines.

This approach leads to results that are representative of the exposure of vehicle occupants since it is based on an average across the body portions closest to the antenna for trunk mount positions, and is conservatively biased because the highest results for each test axis are combined, e.g. the highest head exposure could be in the middle of the seat while the highest lower trunk exposure could be closer to the door.

13.0 Method of Measurement APX6500 VHF Mobile radio with roof mounted antenna(s)

The installation requirements for this radio indicate that in multiple single-band antenna configurations and the antennas should be installed at the center of the roof.

13.1 External/Bystander vehicle MPE measurements

Antenna is located at the center of the roof. (Refer to Appendix A for antenna location and distance)

MPE measurements for bystander (BS) conditions are determined by taking the average of (10) measurements in a 2m vertical line for each of the (5) bystander test locations indicated in Appendix A with 20 cm height increments at the test distance of 90cm from the test vehicle body.

The measurement probe is positioned orthogonal to antenna (typically parallel to ground with a vertically mounted antenna) and aimed directly at the antenna's axis. These measurements are representative of persons other than the operator standing next to the vehicle.

13.2 Internal/Passenger vehicle MPE measurements

Antenna is located at the center of the roof. (Refer to Appendix A for antenna location and distance)

MPE measurements for passenger front seat (PF) and backseat (PB) conditions are determined by taking the average of the (3) measurements (Head, Chest, and Lower Trunk) inside the vehicle for both the front and back seats.

The backseat is a bench seat and therefore each position (Head, Chest & Lower Trunk) were scanned across (horizontally) the seat starting from the middle of the seat to the edge of the seat stopping 20 cm from the vehicle door. Similar process was used in the front bucket seat.

The probe handle is oriented parallel (horizontal) to the ground and pointed towards the back of the vehicle. The probe handle is not oriented normal to the seat surface. The probe head (incorporating the field sensors) is scanned continuously (using the max-hold function available in the meter) along three test axes which are parallel to the seat angle (intended as the line determined by the intersection of the plane of the seat and the plane of the backrest) and are 20 cm from the seat surface. One test axis is at the Head height, another is at the Chest height, and another is at the Lower Trunk height. The maximum field level value recorded for each test axis is logged. The MPE is determined by averaging these three maximum values regardless of the geometrical location where they were observed. For instance, the locations of the three maxima may lie on different vertical (relative to ground) lines.

This approach leads to results that are representative of the exposure of vehicle occupants since it is based on an average across the body portions closest to the antenna for both trunk and roof mount positions, and is conservatively biased because the highest results for each test axis are combined, e.g. the highest head exposure could be in the middle of the seat while the highest lower trunk exposure could be closer to the door.

14.0 MPE Variability Requirement for External/Bystander vehicle MPE measurement

If all the MPE bystander measurements for a particular antenna are below 50% of the FCC MPE limit, no variability testing for that antenna is required.

If one or more MPE bystander measurements for a particular is between 50-80% of the FCC MPE limit, with no results > 80%, variability testing shall be done on the single worst case for that antenna.

For any MPE bystander measurement above 80% of the FCC MPE limit, variability testing shall be done for all of such configuration. When SAR simulation is performed for a particular antenna configuration to determine compliance, variability measurements are not required for that antenna configuration.

15.0 MPE Calculations

The final MPE results for APX6500 VHF Mobile radio and Companion device (DVR 800) are presented in section 17.0. These results are based on 50% duty cycle for APX6500 VHF (PTT operation) and 100% duty cycle for DVR 800 (repeater operation).

Below is an explanation of how the MPE results are calculated. Refer to Appendix F for APX6500 VHF; Appendix G for Companion device (DVR 800).

External to vehicle (Bystander) - 10 measurements are averaged over the body (*Avg_over_body*).

Internal to vehicle (Passengers) - 3 measurements are averaged over the body (*Avg_over_body*).

The Average over Body test methodology is consistent with IEEE/ANSI C95.3-2002 guidelines.

Therefore;

Equation 2 – Power Density Calculation (*Calc._P.D.*)

$$\text{Calc.}_P.D. = (\text{Avg_over_body}) * (\text{probe_frequency_cal_factor}) * (\text{duty_cycle})$$

Note 1: The highest “average” cal factors from the calibration certificates were selected for the applicable frequency range. Linear interpretation was used to determine “probe_frequency_cal_factor” for the specific test frequencies.

Note 2: The E-field probe calibration certificate’s frequency cal factors were determined by measuring V/m. The survey meter’s results were measured in power density (mW/cm^2) and therefore the “probe_frequency_cal_factor” was squared in equation 2 to account for these results.

Note 3: The H-field probe calibration certificate’s frequency cal factors were determined by measuring A/m. The survey meter’s results were measured in A/m and therefore the “Avg_over_body” A/m results were converted to power density (mW/cm^2) using the equation 3. H-field measurements are only applicable to frequencies below 300MHz.

Equation 3 – Converting A/m to mW/cm²

$$mW/cm^2 = (A/m)^2 * 37.699$$

Equation 4 – Power Density Maximum Calculation

$$Max_Calc._P.D. = P.D._calc * \frac{max_output_power}{initial_output_power}$$

Note 4: For initial output power > max_output_power; max_output_power / initial output power = 1

16.0 Antenna Summary

Table below summarizes the tested or evaluated antennas and their descriptions, mount location (roof/trunk), overlap of FCC bands, number of test channels per FCC KDB 447498 (FCC N_c). This information was used to determine the test configurations presented in this report.

Table 8

Antenna No.	Antenna Model	Frequency Range (MHz)	Physical Length (cm)	Gain (dBi)	Remarks	Mount Location (Roof/Trunk)	Overlap FCC Bands (MHz)	FCC N _c
APX6500 VHF								
1	HAD4006A	136-144	52.0	2.15	1/4 wave	Roof	NA	0
2	HAD4007A	144-150.8	49.0	2.15	1/4 wave	Roof	150.8	1
3	HAD4008A	150.8-162	45.5	2.15	1/4 wave	Roof	150.8-162	3
4	HAD4009A	162-174	43.0	2.15	1/4 wave	Roof	162-174	3
5	HAD4016A	136-162	51.3	2.15	1/4 wave	Roof	150.8-162	3
6	HAD4017A	146-174	46.2	2.15	1/4 wave	Roof	150.8-174	4
7	HAD4021A	136-174	51.7	2.15	1/4 wave	Roof	150.8-174	4
8	*HAD4022A	132-174	130.0 (136 MHz) 118.5 (144 MHz) 114.0 (150.8 MHz) 102.7 (158.0125MHz) 96.5 (165.0125MHz) 89.9 (173.0125MHz)	5.15	5/8 wave	Roof	150.8-174	4
9	*RAD4010ARB	136-174	143.5 (136 MHz) 130.5 (144 MHz) 126.8 (150.8 MHz) 116.5 (158.0125 MHz) 112.5 (165.0125 MHz) 103.7 (173.0125 MHz)	5.15	1/2 wave	Roof	150.8-174	4
10	PMAN5100A	2400-2500	5.7 (L) x 1.9 (W)	3.0		Glass mount	2412-2462	3
11	PMAN5101A	2400-2500 / 4900-5900	5.4 (L) x 1.32 (W)	2.7 / 0.2		Glass mount	2412-2462 ; 5180-5825	3
12	AN000163A01	2400-2500 / 4900-5900	7	3.5 / 3.3	Monopole	Roof/ Trunk	2412-2462 ; 5180-5825	3
13	AN000163A05	2400-2500 / 4900-5900	7	2.5 / 1.6	Monopole	Roof/ Trunk	2412-2462 ; 5180-5825	3
DVR 800								
14	HAF4016A	764-870	9	2.15	1/4 wave	Trunk	806-824; 851-869	6

Notes: * Antenna length trimmed to frequency.

17.0 Test Results Summary

17.1 MPE Test Results Summary for APX6500 VHF Mobile radio and DVR 800

Refer to the following appendices for MPE test results for each test configuration: antenna location, test positions (BS1-Bystander test location #1, BS2-Bystander test location #2, BS3-Bystander test location #3, BS4-Bystander test location #4, BS5-Bystander test location #5, PB-Passenger Backseat, PF-Passenger Front seat), E/H field measurements, antenna model & freq. range, maximum output power, initial power, TX frequency, max calculated power density results, applicable FCC specification limits and % of the applicable specification limits.

- Appendix D for APX6500 VHF
- Appendix E for Companion Device (DVR 800)

Table 9 summarized the highest maximum calculated power density and highest % of the applicable specification limit for each standalone transmitters (APX6500 VHF Mobile radio and DVR 800).

Table 9

Test Positions	APX6500 (FCC ID: AZ492FT7130)		DVR 800 (FCC ID: LO6-DVRS800)	
	Power Density (mw/cm ²)	Highest % of Limit	Power Density (mw/cm ²)	Highest % of Limit
FCC US				
Passenger, Front Seat (PF)	0.05	25.2%	0.03	5.8%
Passenger, Back Seat (PB)	0.23	114.6%	0.06	11.1%
Bystander #1 (BS-1)	0.05	23.8%	0.01	1.0%
Bystander #2 (BS-2)	0.06	29.1%	0.02	2.9%
Bystander #3 (BS-3)	0.05	26.3%	0.02	3.0%
Bystander #4 (BS-4)	0.04	17.8%	0.03	4.9%
Bystander #5 (BS-5)	0.03	16.7%	0.02	3.0%
ISED Canada				
Passenger, Front Seat (PF)	0.05	40.0%	0.03	12.7%
Passenger, Back Seat (PB)	0.23	177.6%	0.06	23.5%
Bystander #1 (BS-1)	0.05	37.1%	0.01	2.2%
Bystander #2 (BS-2)	0.06	45.9%	0.02	6.1%
Bystander #3 (BS-3)	0.05	42.5%	0.02	6.4%
Bystander #4 (BS-4)	0.04	27.6%	0.03	10.5%
Bystander #5 (BS-5)	0.03	25.9%	0.02	6.4%

17.2 MPE Test Results for Bluetooth and WLAN

Antenna PMAN5100A and PMAN5101A was intended for mounting on the windshield of the vehicle. These antennas should be installed close to the top, and on the front windshield only. Antennas AN000163A01 and AN000163A05 support WLAN 2.4 GHz / 5 GHz should be installed at roof or trunk of the vehicle. WLAN 2.4 GHz and 5 GHz will not transmit simultaneously.

MPE calculation was use to determine power density for these transmitters due to lower power. According to FCC's OET Bulletin 65 Edition 97-01 Section 2, calculations can be made to predict RF field strength and power density levels around typical RF sources. Equation (5) is generally accurate in far-field of an antenna.

Equation 5 – Power Density Calculation

$$S = \frac{P_t G}{4\pi d^2} F$$

Equation (5) accounts for the maximum duty cycle of the signal, and the factor, F, to provide a worst-case prediction of power density per FCC OET Bulletin 65, Edition 97-01 1997.

Where:

- S = power density
- P_t = maximum output power scaled by the maximum duty cycle of the signal
- G = power gain of the antenna in the direction of interest relative to an isotropic radiator
- d = distance from antenna
- F = Enhancement factor [1 or 2.56 for predicting ground-level field strength]

Table 14 summarized the MPE calculation for each standalone transmitter bands, Bluetooth and WLAN.

Table 10

Antenna #	Max Power (W)	Duty Cycle (%)	Tx Frequency (MHz)	Antenna Gain (dBi)	Cable Loss, L (dB)	Dist., d (cm)	Enhance Factor, F	Max Calc. MPE (mW/cm ²)	MPE Spec Limit (mW/cm ²)					
									FCC	% To FCC Spec Limit	ICNIRP	% To ICNIRP Spec Limit	ISED limit	% To ISED Spec Limit
WLAN 2.4 GHz														
AN000163A01	0.040	100%	2412.0	3.50	0.00	20	1.00	0.018	1.00	1.77	1.00	1.77	0.54	3.30
AN000163A01	0.040	100%	2437.0	3.50	0.00	20	1.00	0.018	1.00	1.77	1.00	1.77	0.54	3.28
AN000163A01	0.040	100%	2462.0	3.50	0.00	20	1.00	0.018	1.00	1.77	1.00	1.77	0.54	3.26
AN000163A05	0.040	100%	2412.0	2.50	0.00	20	1.00	0.014	1.00	1.41	1.00	1.41	0.54	2.62
AN000163A05	0.040	100%	2437.0	2.50	0.00	20	1.00	0.014	1.00	1.41	1.00	1.41	0.54	2.61
AN000163A05	0.040	100%	2462.0	2.50	0.00	20	1.00	0.014	1.00	1.41	1.00	1.41	0.54	2.59
PMAN5100A	0.040	100%	2412.0	3.00	0.00	20	1.00	0.016	1.00	1.58	1.00	1.58	0.54	2.94
PMAN5100A	0.040	100%	2437.0	3.00	0.00	20	1.00	0.016	1.00	1.58	1.00	1.58	0.54	2.92
PMAN5100A	0.040	100%	2462.0	3.00	0.00	20	1.00	0.016	1.00	1.58	1.00	1.58	0.54	2.90
PMAN5101A	0.040	100%	2412.0	2.70	0.00	20	1.00	0.015	1.00	1.47	1.00	1.47	0.54	2.75
PMAN5101A	0.040	100%	2437.0	2.70	0.00	20	1.00	0.015	1.00	1.47	1.00	1.47	0.54	2.73
PMAN5101A	0.040	100%	2462.0	2.70	0.00	20	1.00	0.015	1.00	1.47	1.00	1.47	0.54	2.71
WLAN 5 GHz														
AN000163A01	0.016	100%	5180.0	3.30	0.00	20	1.00	0.007	1.00	0.67	1.00	0.67	0.90	0.75
AN000163A01	0.016	100%	5502.5	3.30	0.00	20	1.00	0.007	1.00	0.67	1.00	0.67	0.94	0.71
AN000163A01	0.016	100%	5825.0	3.30	0.00	20	1.00	0.007	1.00	0.67	1.00	0.67	0.98	0.69
AN000163A05	0.016	100%	5180.0	1.60	0.00	20	1.00	0.005	1.00	0.46	1.00	0.46	0.90	0.50
AN000163A05	0.016	100%	5502.5	1.60	0.00	20	1.00	0.005	1.00	0.46	1.00	0.46	0.94	0.48
AN000163A05	0.016	100%	5825.0	1.60	0.00	20	1.00	0.005	1.00	0.46	1.00	0.46	0.98	0.46
PMAN5101A	0.016	100%	5180.0	0.20	0.00	20	1.00	0.003	1.00	0.33	1.00	0.33	0.90	0.36
PMAN5101A	0.016	100%	5502.5	0.20	0.00	20	1.00	0.003	1.00	0.33	1.00	0.33	0.94	0.35
PMAN5101A	0.016	100%	5825.0	0.20	0.00	20	1.00	0.003	1.00	0.33	1.00	0.33	0.98	0.34
Bluetooth 2.4 GHz														
AN000163A01	0.011	100%	2402.0	3.50	0.00	20	1.00	0.005	1.00	0.50	1.00	0.50	0.54	0.93
AN000163A01	0.011	100%	2441.0	3.50	0.00	20	1.00	0.005	1.00	0.50	1.00	0.50	0.54	0.92
AN000163A01	0.011	100%	2480.0	3.50	0.00	20	1.00	0.005	1.00	0.50	1.00	0.50	0.55	0.91
AN000163A05	0.011	100%	2402.0	2.50	0.00	20	1.00	0.004	1.00	0.40	1.00	0.40	0.54	0.74
AN000163A05	0.011	100%	2441.0	2.50	0.00	20	1.00	0.004	1.00	0.40	1.00	0.40	0.54	0.73
AN000163A05	0.011	100%	2480.0	2.50	0.00	20	1.00	0.004	1.00	0.40	1.00	0.40	0.55	0.73
PMAN5100A	0.011	100%	2402.0	3.00	0.00	20	1.00	0.004	1.00	0.45	1.00	0.45	0.54	0.83
PMAN5100A	0.011	100%	2441.0	3.00	0.00	20	1.00	0.004	1.00	0.45	1.00	0.45	0.54	0.82
PMAN5100A	0.011	100%	2480.0	3.00	0.00	20	1.00	0.004	1.00	0.45	1.00	0.45	0.55	0.81
PMAN5101A	0.011	100%	2402.0	2.70	0.00	20	1.00	0.004	1.00	0.42	1.00	0.42	0.54	0.78
PMAN5101A	0.011	100%	2441.0	2.70	0.00	20	1.00	0.004	1.00	0.42	1.00	0.42	0.54	0.77
PMAN5101A	0.011	100%	2480.0	2.70	0.00	20	1.00	0.004	1.00	0.42	1.00	0.42	0.55	0.76

Notes:

- 1) Distance from antenna (d), 20cm for more conservative estimation.
- 2) Cable loss (L), all cable loss include in antenna gain, so should be 0 dB.
- 3) Enhancement Factor (F), 1 (Ground reflection already factor in during antenna characterization)

17.3 Simultaneous Transmission

APX6500 VHF will transmit simultaneously with Companion device (DVR 800); refer to Table 7 for all simultaneous transmission conditions.

The combine MPE results for APX6500 VHF and Companion device (DVR 800) were calculated base on the percent of MPE limit for each applicable test channels according to the formula below. This is due to the signals emitted by each individual transmitter are statistically uncorrelated; the collective compliance of the transmitters is determined by summing the individual ratios between actual measured power density (S) and maximum allowed MPE exposure. Compliance is achieved if the total exposure (T) is less than one.

Formula:

$$T = \frac{S_1}{MPE_1} + \frac{S_2}{MPE_2} + \dots < 1$$

The highest combined power density percentage of the applicable specification limits are indicating in table 11.

Table 11- Highest Combine MPE % of limits

Test Positions	APX6500 (FCC ID: AZ492FT7130)		DVR 800 (FCC ID: LO6-DVRS800)	APX6500 + WLAN + DVR 800	
	136-174 MHz	WLAN	806-825 MHz; 851-870 MHz		
	[1] Highest % of Limit	[2] Highest % of Limit	[3] Highest % of Limit	[1]+[2]+[3] Combine % of Limit	Table No.
FCC US					
Passenger, Front Seat (PF)	25.2%	1.77%	5.8%	32.8%	
Passenger, Back Seat (PB)	114.6%	1.77%	11.1%	127.5%	12
Bystander #1 (BS-1)	23.8%	1.77%	1.0%	26.6%	
Bystander #2 (BS-2)	29.1%	1.77%	2.9%	33.8%	
Bystander #3 (BS-3)	26.3%	1.77%	3.0%	31.1%	
Bystander #4 (BS-4)	17.8%	1.77%	4.9%	24.5%	
Bystander #5 (BS-5)	16.7%	1.77%	3.0%	21.5%	
ISED Canada					
Passenger, Front Seat (PF)	40.0%	3.30%	12.7%	56.0%	
Passenger, Back Seat (PB)	177.6%	3.30%	23.5%	204.4%	13
Bystander #1 (BS-1)	37.1%	3.30%	2.2%	42.6%	
Bystander #2 (BS-2)	45.9%	3.30%	6.1%	55.3%	
Bystander #3 (BS-3)	42.5%	3.30%	6.4%	52.2%	
Bystander #4 (BS-4)	27.6%	3.30%	10.5%	41.4%	
Bystander #5 (BS-5)	25.9%	3.30%	6.4%	35.6%	

Table 12 (a) – Combined MPE % of FCC US limit (Passenger, Back Seat)
 (APX6500 VHF_E Field & Companion Device DVR 800 Field)

				DVRS 800 Antenna (Trunk Mounted)						
				E/H Field		E Field				
				DVRS Antenna	HAF4016A, 1/4 Wave (764-870MHz)	HAF4016A, 1/4 Wave (764-870MHz)	HAF4016A, 1/4 Wave (764-870MHz)	HAF4016A, 1/4 Wave (764-870MHz)	HAF4016A, 1/4 Wave (764-870MHz)	HAF4016A, 1/4 Wave (764-870MHz)
				DVR Freq (MHz)	806.0000	815.0000	824.0000	851.0000	860.0000	869.0000
Mobile (roof Mounted)	E/H Field	APX6500 Antenna (Roof Mounted)	LMR Freq (MHz)	% of FCC Limit	10.4	11.1	8.7	7.9	6.8	4.0
			HAD4007A, 1/4 Wave (144)	150.8000	110.7	121.1	121.8	119.4	118.6	117.5
		HAD4008A, 1/4 Wave (150.8-162 MHz)	150.8000	95.3	105.7	106.4	104.0	103.2	102.1	99.3
			156.4000	110.9	121.3	122.0	119.6	118.8	117.7	114.9
			162.0000	116.4	126.8	127.5	125.1	124.3	123.2	120.4
		HAD4009A, 1/4 Wave (162-174 MHz)	162.0000	108.4	118.8	119.5	117.1	116.3	115.2	112.4
			165.0125	105.2	115.6	116.3	113.9	113.1	112.0	109.2
			173.0125	67.7	78.1	78.8	76.4	75.6	74.5	71.7
		HAD4016A, 1/4 Wave (136-162 MHz)	150.8000	99.4	109.8	110.5	108.1	107.3	106.2	103.4
			156.4000	93.5	103.9	104.6	102.2	101.4	100.3	97.5
			162.0000	90.4	100.8	101.5	99.1	98.3	97.2	94.4
		HAD4017A, 1/4 Wave (146- 174 MHz)	150.8000	85.7	96.1	96.8	94.4	93.6	92.5	89.7
			158.0125	102.2	112.6	113.3	110.9	110.1	109.0	106.2
			165.0125	111.6	122.0	122.7	120.3	119.5	118.4	115.6
		HAD4021A, 1/4 Wave (136- 174MHz)	173.0125	64.7	75.1	75.8	73.4	72.6	71.5	68.7
			150.8000	85.4	95.8	96.5	94.1	93.3	92.2	89.4
			158.0125	89.4	99.8	100.5	98.1	97.3	96.2	93.4
		HAD4022A, 5/8 Wave (132- -174 MHz)	165.0125	90.7	101.1	101.8	99.4	98.6	97.5	94.7
			173.0125	56.1	66.5	67.2	64.8	64.0	62.9	60.1
			150.8000	18.4	28.8	29.5	27.1	26.3	25.2	22.4
		RAD4010ARB, 1/2 wave (136-174 MHz)	158.0125	27.8	38.2	38.9	36.5	35.7	34.6	31.8
			165.0125	45.0	55.4	56.1	53.7	52.9	51.8	49.0
			173.0125	34.1	44.5	45.2	42.8	42.0	40.9	38.1
		RAD4010ARB, 1/2 wave (136-174 MHz)	150.8000	13.8	24.2	24.9	22.5	21.7	20.6	17.8
			158.0125	14.1	24.5	25.2	22.8	22.0	20.9	18.1
			165.0125	19.7	30.1	30.8	28.4	27.6	26.5	23.7
			173.0125	22.9	33.3	34.0	31.6	30.8	29.7	26.9

Notes:

Blue Font- Configurations require SAR simulations.

**Table 12 (b) – Combined MPE % of FCC US limit (Passenger, Back Seat)
(APX6500 VHF_H Field & Companion Device DVR 800 Field)**

						DVRS 800 Antenna (Trunk Mounted)					
		E/H Field		E Field							
		DVRS Antenna		HAF4016A, 1/4 Wave (764-870MHz)	HAF4016A, 1/4 Wave (764-870MHz)	HAF4016A, 1/4 Wave (764-870MHz)	HAF4016A, 1/4 Wave (764-870MHz)	HAF4016A, 1/4 Wave (764-870MHz)	HAF4016A, 1/4 Wave (764-870MHz)	HAF4016A, 1/4 Wave (764-870MHz)	
		DVR Freq (MHz)		806.0000	815.0000	824.0000	851.0000	860.0000	869.0000		
Mobile (roof Mounted)	E/H Field	APX6500 Antenna (Roof Mounted)	LMR Freq (MHz)	% of FCC Limit	10.4	11.1	8.7	7.9	6.8	4.0	
		H-Field									
		HAD4007A, 1/4 Wave (144- 150.8 MHz)	150.8000	34.5	44.9	45.6	43.2	42.4	41.3	38.5	
		HAD4008A, 1/4 Wave (150.8-162 MHz)	150.8000	27.4	37.8	38.5	36.1	35.3	34.2	31.4	
			156.4000	40.2	50.6	51.3	48.9	48.1	47.0	44.2	
			162.0000	38.9	49.3	50.0	47.6	46.8	45.7	42.9	
		HAD4009A, 1/4 Wave (162-174 MHz)	162.0000	34.5	44.9	45.6	43.2	42.4	41.3	38.5	
			165.0125	35.2	45.6	46.3	43.9	43.1	42.0	39.2	
			173.0125	28.7	39.1	39.8	37.4	36.6	35.5	32.7	
		HAD4016A, 1/4 Wave (136-162 MHz)	150.8000	29.9	40.3	41.0	38.6	37.8	36.7	33.9	
			156.4000	34.5	44.9	45.6	43.2	42.4	41.3	38.5	
			162.0000	30.6	41.0	41.7	39.3	38.5	37.4	34.6	
		HAD4017A, 1/4 Wave (146- 174 MHz)	150.8000	26.2	36.6	37.3	34.9	34.1	33.0	30.2	
			158.0125	35.6	46.0	46.7	44.3	43.5	42.4	39.6	
			165.0125	33.5	43.9	44.6	42.2	41.4	40.3	37.5	
		HAD4021A, 1/4 Wave (136- 174MHz)	173.0125	26.7	37.1	37.8	35.4	34.6	33.5	30.7	
			150.8000	25.9	36.3	37.0	34.6	33.8	32.7	29.9	
			158.0125	33.1	43.5	44.2	41.8	41.0	39.9	37.1	
		HAD4022A, 5/8 Wave (132- 174 MHz)	165.0125	31.0	41.4	42.1	39.7	38.9	37.8	35.0	
			173.0125	23.9	34.3	35.0	32.6	31.8	30.7	27.9	
			150.8000	9.7	20.1	20.8	18.4	17.6	16.5	13.7	
		RAD4010ARB, 1/2 wave (136-174 MHz)	158.0125	12.5	22.9	23.6	21.2	20.4	19.3	16.5	
			165.0125	21.8	32.2	32.9	30.5	29.7	28.6	25.8	
			173.0125	15.4	25.8	26.5	24.1	23.3	22.2	19.4	
		RAD4010ARB, 1/2 wave (136-174 MHz)	150.8000	7.4	17.8	18.5	16.1	15.3	14.2	11.4	
			158.0125	8.7	19.1	19.8	17.4	16.6	15.5	12.7	
			165.0125	10.8	21.2	21.9	19.5	18.7	17.6	14.8	
			173.0125	12.6	23.0	23.7	21.3	20.5	19.4	16.6	

**Table 13 (a) – Combined MPE % of ISED Canada limit (Passenger, Back Seat)
(APX6500 VHF_E Field & Companion Device DVR 800)**

				DVRS 800 Antenna (Trunk Mounted)						
		E/H Field		E Field						
		DVRS Antenna		HAF4016A, 1/4 Wave (764-870MHz)	HAF4016A, 1/4 Wave (764-870MHz)	HAF4016A, 1/4 Wave (764-870MHz)	HAF4016A, 1/4 Wave (764-870MHz)	HAF4016A, 1/4 Wave (764-870MHz)	HAF4016A, 1/4 Wave (764-870MHz)	
		DVR Freq (MHz)		806.0000	815.0000	824.0000	851.0000	860.0000	869.0000	
Mobile (roof mounted)	E/H Field	APX6500 Antenna (Roof Mounted)	LMR Freq (MHz)	% of ISED Limit	21.9	23.5	18.6	17.0	14.7	8.7
			HAD4006A, 1/4 Wave (136-144 MHz)	140.0000	174.7	196.6	198.2	193.3	191.7	189.4
			144.0000	162.3	184.2	185.8	180.9	179.3	177.0	171.0
		HAD4007A, 1/4 Wave (144-150.8 MHz)	144.0000	150.9	172.8	174.4	169.5	167.9	165.6	159.6
			150.8000	172.0	193.9	195.5	190.6	189.0	186.7	180.7
		HAD4008A, 1/4 Wave (150.8-162 MHz)	150.8000	148.2	170.1	171.7	166.8	165.2	162.9	156.9
			156.4000	172.3	194.2	195.8	190.9	189.3	187.0	181.0
			162.0000	180.9	202.8	204.4	199.5	197.9	195.6	189.6
		HAD4009A, 1/4 Wave (162-174 MHz)	162.0000	168.4	190.3	191.9	187.0	185.4	183.1	177.1
			165.0125	163.4	185.3	186.9	182.0	180.4	178.1	172.1
			173.0125	105.4	127.3	128.9	124.0	122.4	120.1	114.1
		HAD4016A, 1/4 Wave (136-162 MHz)	144.0000	149.7	171.6	173.2	168.3	166.7	164.4	158.4
			150.8000	154.5	176.4	178.0	173.1	171.5	169.2	163.2
			156.4000	145.4	167.3	168.9	164.0	162.4	160.1	154.1
			162.0000	140.6	162.5	164.1	159.2	157.6	155.3	149.3
		HAD4017A, 1/4 Wave (146-174 MHz)	146.0000	93.0	114.9	116.5	111.6	110.0	107.7	101.7
			150.8000	133.3	155.2	156.8	151.9	150.3	148.0	142.0
			158.0125	158.9	180.8	182.4	177.5	175.9	173.6	167.6
			165.0125	173.4	195.3	196.9	192.0	190.4	188.1	182.1
			173.0125	100.7	122.6	124.2	119.3	117.7	115.4	109.4
		HAD4021A, 1/4 Wave (136-174MHz)	144.0000	132.6	154.5	156.1	151.2	149.6	147.3	141.3
			150.8000	132.8	154.7	156.3	151.4	149.8	147.5	141.5
			158.0125	139.0	160.9	162.5	157.6	156.0	153.7	147.7
			165.0125	141.0	162.9	164.5	159.6	158.0	155.7	149.7
			173.0125	87.4	109.3	110.9	106.0	104.4	102.1	96.1
		HAD4022A, 5/8 Wave (132 -174 MHz)	144.0000	33	54.9	56.5	51.6	50.0	47.7	41.7
			150.8000	29	50.9	52.5	47.6	46.0	43.7	37.7
			158.0125	43.5	65.4	67.0	62.1	60.5	58.2	52.2
			165.0125	70.2	92.1	93.7	88.8	87.2	84.9	78.9
			173.0125	53.3	75.2	76.8	71.9	70.3	68.0	62.0
		RAD4010ARB, 1/2 wave (136-174 MHz)	144.0000	25.3	47.2	48.8	43.9	42.3	40.0	34.0
			150.8000	21.9	43.8	45.4	40.5	38.9	36.6	30.6
			158.0125	22.3	44.2	45.8	40.9	39.3	37	31
			165.0125	31.1	53	54.6	49.7	48.1	45.8	39.8
			173.0125	36.0	57.9	59.5	54.6	53	50.7	44.7

Notes:
Blue Font- Configurations require SAR simulations.

**Table 13 (b) – Combined MPE % of ISED Canada limit (Passenger, Back Seat)
(APX6500 VHF_H Field & Companion Device DVR 800)**

				DVR8 800 Antenna (Trunk Mounted)							
				E/H Field		E Field					
				DVR8 Antenna		HAF4016A, 1/4 Wave (764-870MHz)	HAF4016A, 1/4 Wave (764-870MHz)	HAF4016A, 1/4 Wave (764-870MHz)	HAF4016A, 1/4 Wave (764-870MHz)	HAF4016A, 1/4 Wave (764-870MHz)	HAF4016A, 1/4 Wave (764-870MHz)
				DVR Freq (MHz)		806.0000	815.0000	824.0000	851.0000	860.0000	869.0000
Mobile (roof mounted)	E/H Field	APX6500 Antenna (Roof Mounted)			21.9	23.5	18.6	17.0	14.7	8.7	
			LMR Freq (MHz)	% of ISED Limit							
Mobile (roof mounted)	H Field	HAD4006A, 1/4 Wave (136-144 MHz)	140.0000	49.1	71.0	72.6	67.7	66.1	63.8	57.8	
			144.0000	49.5	71.4	73.0	68.1	66.5	64.2	58.2	
		HAD4007A, 1/4 Wave (144-150.8 MHz)	144.0000	45.7	67.6	69.2	64.3	62.7	60.4	54.4	
			150.8000	54.0	75.9	77.5	72.6	71.0	68.7	62.7	
		HAD4008A, 1/4 Wave (150.8-162 MHz)	150.8000	43.0	64.9	66.5	61.6	60.0	57.7	51.7	
			156.4000	62.7	84.6	86.2	81.3	79.7	77.4	71.4	
			162.0000	60.8	82.7	84.3	79.4	77.8	75.5	69.5	
		HAD4009A, 1/4 Wave (162-174 MHz)	162.0000	53.9	75.8	77.4	72.5	70.9	68.6	62.6	
			165.0125	55.0	76.9	78.5	73.6	72.0	69.7	63.7	
			173.0125	45.0	66.9	68.5	63.6	62.0	59.7	53.7	
		HAD4016A, 1/4 Wave (136-162 MHz)	144.0000	44.6	66.5	68.1	63.2	61.6	59.3	53.3	
			150.8000	46.9	68.8	70.4	65.5	63.9	61.6	55.6	
			156.4000	54.0	75.9	77.5	72.6	71.0	68.7	62.7	
			162.0000	47.9	69.8	71.4	66.5	64.9	62.6	56.6	
		HAD4017A, 1/4 Wave (146-174 MHz)	146.0000	28.7	50.6	52.2	47.3	45.7	43.4	37.4	
			150.8000	41.2	63.1	64.7	59.8	58.2	55.9	49.9	
			158.0125	55.7	77.6	79.2	74.3	72.7	70.4	64.4	
			165.0125	52.4	74.3	75.9	71.0	69.4	67.1	61.1	
		HAD4021A, 1/4 Wave (136 -174MHz)	173.0125	41.9	63.8	65.4	60.5	58.9	56.6	50.6	
			144.0000	39.6	61.5	63.1	58.2	56.6	54.3	48.3	
			150.8000	40.6	62.5	64.1	59.2	57.6	55.3	49.3	
			158.0125	51.8	73.7	75.3	70.4	68.8	66.5	60.5	
		HAD4022A, 5/8 Wave (132-174 MHz)	165.0125	48.5	70.4	72.0	67.1	65.5	63.2	57.2	
			173.0125	37.5	59.4	61.0	56.1	54.5	52.2	46.2	
			144.0000	17.0	38.9	40.5	35.6	34.0	31.7	25.7	
			150.8000	15.6	37.5	39.1	34.2	32.6	30.3	24.3	
		RAD4010ARB, 1/2 wave (136-174 MHz)	158.0125	19.9	41.8	43.4	38.5	36.9	34.6	28.6	
			165.0125	34.3	56.2	57.8	52.9	51.3	49.0	43.0	
			173.0125	24.4	46.3	47.9	43.0	41.4	39.1	33.1	
			144.0000	11.9	33.8	35.4	30.5	28.9	26.6	20.6	
			150.8000	12.0	33.9	35.5	30.6	29	26.7	20.7	
			158.0125	14.1	36	37.6	32.7	31.1	28.8	22.8	
			165.0125	17.2	39.1	40.7	35.8	34.2	31.9	25.9	
			173.0125	20.0	41.9	43.5	38.6	37	34.7	28.7	

18.0 Conclusion

The assessment for APX6500 VHF and Companion device (DVR 800) were performed as indicates in section 17.1 with an output power range listed in Table 6. The maximum allowable output power is equal to the upper limit of the final test factory transmit power specification listed in Table 6. The highest power density results for APX6500 VHF and Companion device (DVR 800) scaled to maximum allowable power output are indicated in Table 14 (FCC US) and Table 15 (ISED Canada) for internal/passenger of to the vehicle, and external/bystander to the vehicle.

These MPE results herein demonstrate compliance to FCC Occupation/Controlled Exposure limit. However, FCC rules required compliance for Passengers and Bystanders to FCC General Population / Uncontrolled limits. Maximum Combined MPE percentage in bold exceed General Population / Uncontrolled limit.

Table 14 – Maximum MPE RF Exposure Summary (FCC US)

APX6500 VHF band (FCC ID: AZ492FT7130) Roof Mounted Antenna					
Equipment Class	Frequency Band (MHz)	Passenger		Bystander	
		Power Density (mw/cm ²)	Highest % of Limit	Power Density (mw/cm ²)	Highest % of Limit
TNB	150.8-173.4 MHz	0.230	114.6%	0.060	29.1%
DTS	WLAN (2412-2462)	0.018	1.77%	0.018	1.77%
NII	WLAN (5180 - 5825)	0.007	0.67%	0.007	0.67%
DSS	BT (2402-2480)	0.005	0.50%	0.005	0.50%
Companion Device DVR 800 (FCC ID: LO6-DVRS800) Trunk Mounted Antenna					
Equipment Class	Frequency Band (MHz)	Passenger		Bystander	
		Power Density (mw/cm ²)	Highest % of Limit	Power Density (mw/cm ²)	Highest % of Limit
TNB	806-824; 851-869	0.060	11.1%	0.028	4.9%
Simultaneous Transmissions					
Simultaneous Transmissions conditions		Passenger		Bystander	
		Highest Combine % of limit		Highest Combine % of limit	
APX6500 (VHF band) + WLAN + DVR 800		127.5%		33.8%	

Note: Result in bold required SAR Simulation.

Table 15 – Maximum MPE RF Exposure Summary (ISED Canada)

APX6500 VHF band (IC: 109U-92FT7130) Roof Mounted Antenna				
Frequency Band (MHz)	Passenger		Bystander	
	Power Density (mw/cm²)	Highest % of Limit	Power Density (mw/cm²)	Highest % of Limit
138-174	0.230	177.6%	0.060	45.9%
2.4GHz WLAN (2412-2462)	0.018	3.3%	0.018	3.3%
5GHz WLAN (5180 - 5825)	0.007	0.8%	0.007	0.8%
BT (2402-2480)	0.005	0.9%	0.005	0.9%
Companion Device DVR 800 (IC: 2098B-DVRS800) Trunk Mounted Antenna				
Frequency Band (MHz)	Passenger		Bystander	
	Power Density (mw/cm²)	Highest % of Limit	Power Density (mw/cm²)	Highest % of Limit
806-824; 851-869	0.060	23.5%	0.028	10.5%
Simultaneous Transmissions				
Simultaneous Transmissions conditions	Passenger		Bystander	
	Highest Combine % of limit		Highest Combine % of limit	
APX6500 (VHF band) + WLAN + DVR 800	204.4%		55.3%	

Note: Result in bold required SAR Simulation.

Although MPE is a convenient method of demonstrating RF Exposure requirements, SAR is recognized as the “basic restriction”. For those configurations indicate with blue font in Table 12, Table 13, compliance to the General Population / Uncontrolled SAR 1g limit of 1.6 W/kg is demonstrated through SAR computational analysis.

The computational results show that this APX6500 VHF, when used with Companion device DVR 800 and specified antennas, exhibit a maximum combine SAR are indicated in the Table 16.

Table 16

	Exposure Conditions	Combined SAR (W/kg)	
		1-g	WB
FCC	Passenger Back	0.355	0.015
ISED	Passenger Back	0.408	0.019

19.0 User Instructions Considerations

In order to facilitate the requirements for occupational exposure limits, the Safety Manual for this radio requires the radio operator to maintain 90 cm in all directions between the vehicle and external persons while transmitting.

Appendix A - Antenna Locations, Test Distances, and Cable Losses

Antenna locations

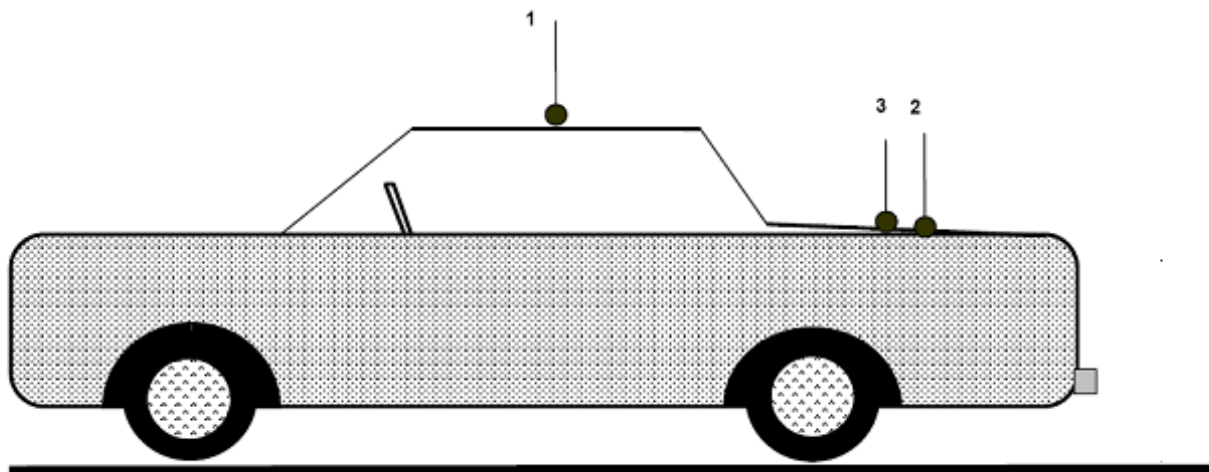

1. Roof (center)
2. Trunk (85cm from back of the back seat)
3. Trunk (center)

Passenger Antenna mounting

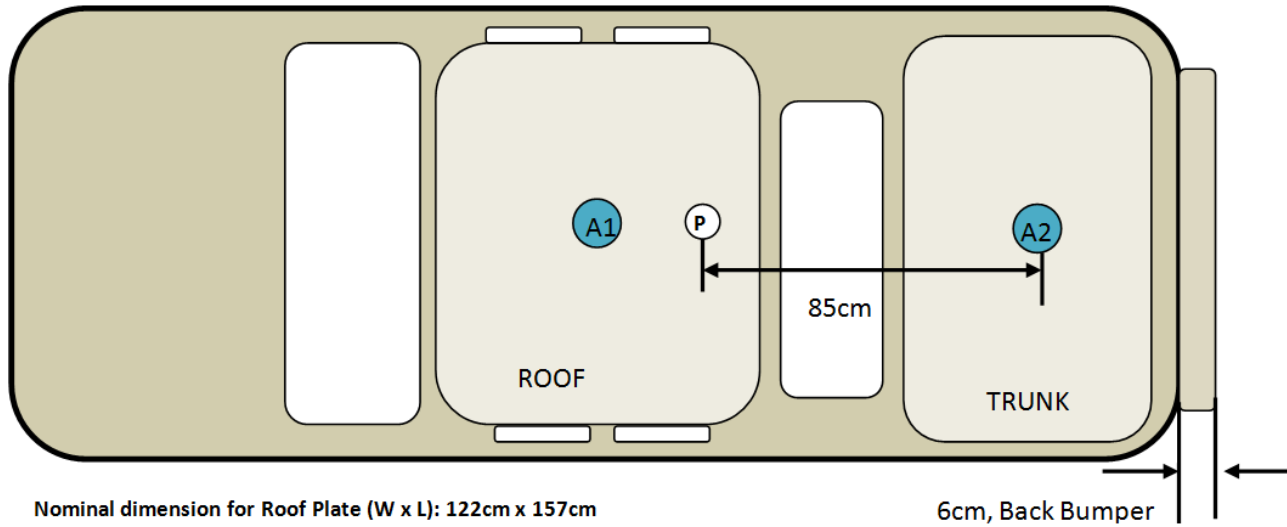

Nominal dimension for Roof Plate (W x L): 122cm x 157cm

6cm, Back Bumper

Nominal dimension for Trunk Plate (W x L): 138cm x 72cm

Notes:

- 1.) Antenna location A1: APX6500 mobile radio roof antenna mounting locations for front and back passenger testing.
- 2.) Antenna location A2: DVR trunk antenna mounting locations for front and back passenger testing
- 3.) Total distance between trunk mount antenna and rear passenger is 85cm

Bystander Antenna mounting

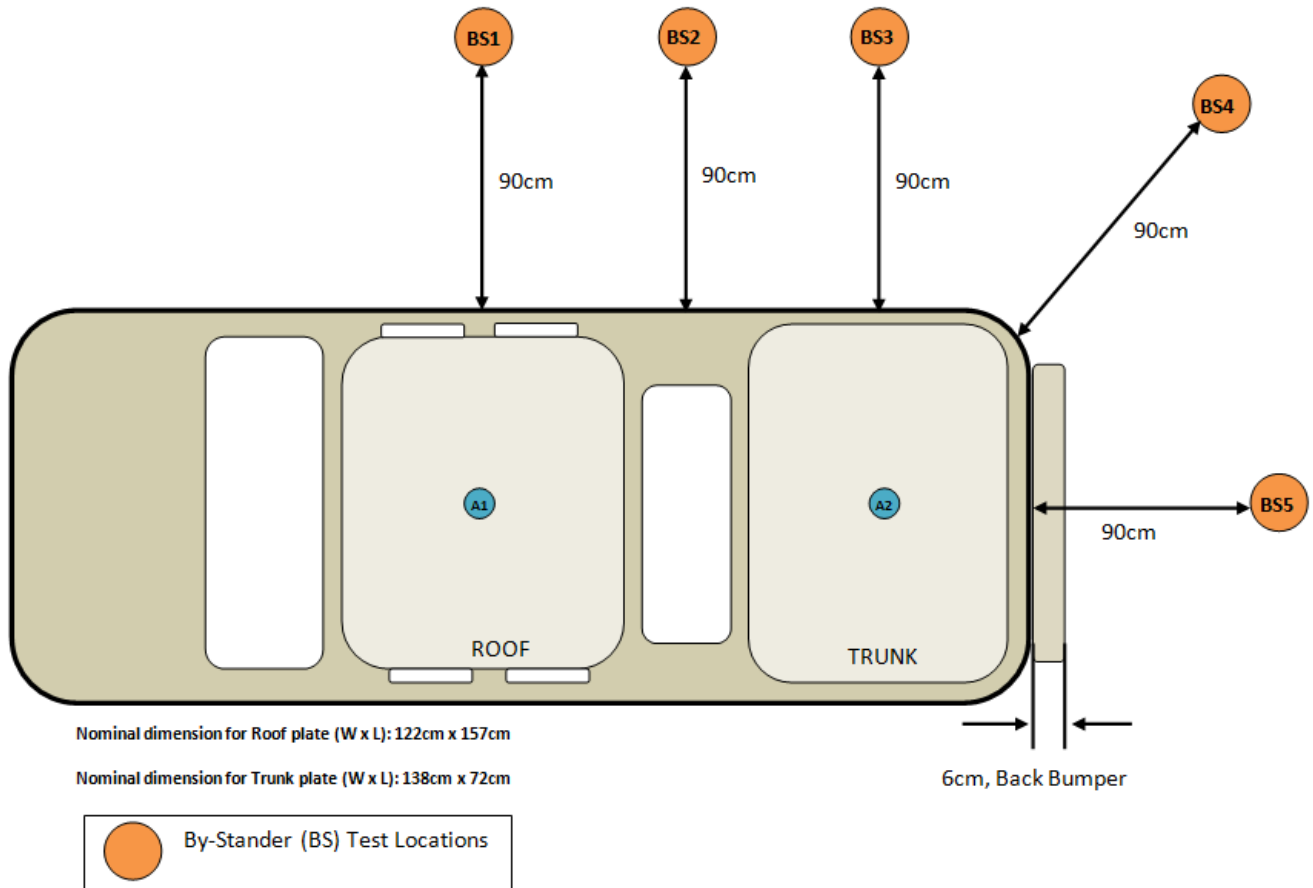

Note:

- 1.) Antenna location A1: APX6500 mobile radio roof antenna mounting locations for passenger and bystander testing
- 2.) Antenna location A2: DVR trunk antenna mounting locations for bystander testing
- 3.) Bystander location BS2: Center point of the bystander test location BS1 and test location BS3
- 4.) Bystander location BS (1-5): 90cm away from the vehicle body. Apply for both roof and trunk testing

Seat scan areas (Applicable to both front and back seats)

Meter - Probe

 Probe diameter is 5.5cm

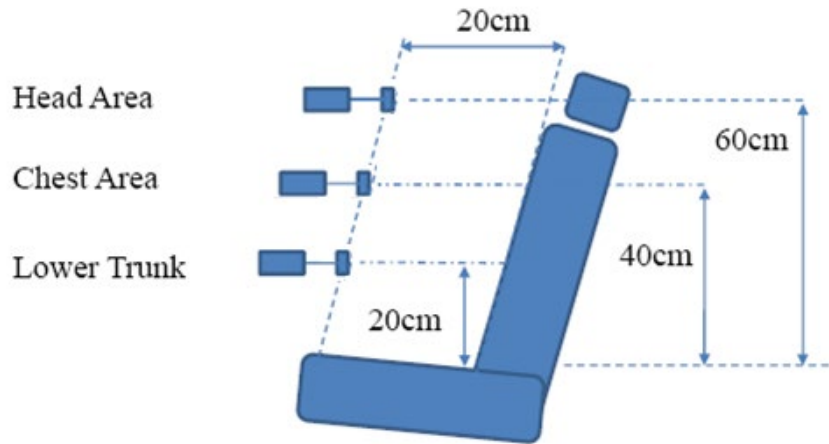

MPE Test Configuration

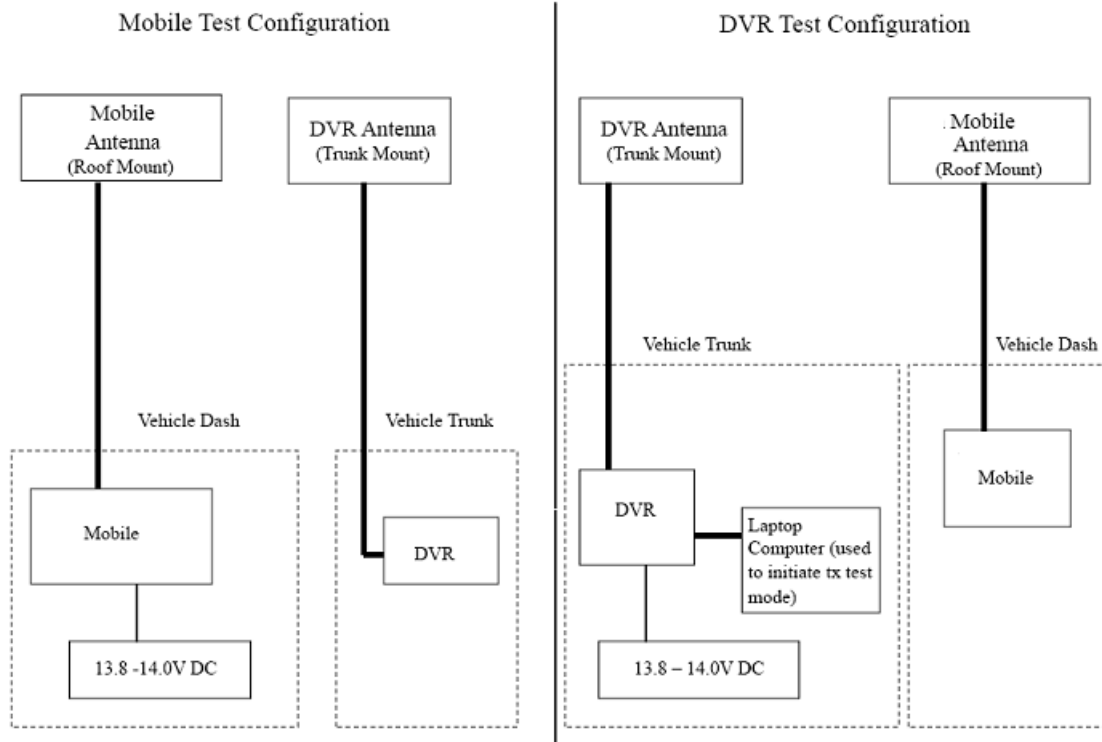

Cable Losses

Test Cable

Teflon RG58A/U Loss Per 100 Feet

160 MHz - 5 dB

450 MHz - 9 dB

1 GHz - 13.8 dB

Customer Cable

RG-58A/U Loss Per 100 Feet (For LMR)

136 MHz – 5.5 dB

450 MHz – 9.6 dB

900 MHz – 13.9 dB

PPF 240 Loss Per 100 Feet (For BT/WLAN)

2500 MHz - 12.9 dB

Appendix B - Probe Calibration Certificates

Service Test Report

QAF 1126, 03/11

Report ID: 129185



Certificate of Test Conformance

Page 1 of 1

Reference: S 000045944

Customer: Motorola Solutions Malaysia Sdn Bhd (Innoplex) - Plot 2A, Medan Bayan Lepas, Mukim 12 SWD 11900 Bayan Lepas Penang, Malaysia. Bayan Lepas Penang 11900 Malaysia

The instrument listed below has been tested and verified to Internal Quality Standards. Test data is Attached. Equipment used during instrument testing is controlled by laboratory compliance with ISO/IEC 17025-2005 and ANSI/NCSL Z540-1-1994 using ETS-Lindgren Quality Management System internal procedures.

<u>Manufacturer</u>	ETS-Lindgren	<u>Status In</u>	In Tolerance
<u>Instrument Type</u>	RF Survey Meter	<u>Date Completed</u>	01-Apr-19
<u>Model</u>	HI-2200	<u>Status Out</u>	Compliant with Internal Quality Standards
<u>Serial Number/ID</u>	00206805		

Remarks

Functional test performed with customer's E100 S/N: 00126277 and H200 S/N: 00084225. Firmware Updated.

I would like to take this opportunity to express our appreciation for using ETS-Lindgren for your EMI test equipment services and I am looking forward to continued business with your organization. Please feel free to contact our offices at (512) 531-6400, if you have any questions regarding this report.

Sincerely,

George Cisneros
Calibration Supervisor

Date Attested: 01-Apr-19



Cert I.D.: 129186

1301 Arrow Point Drive
Cedar Park, Texas 78613
(512) 531-6400

Certificate of Calibration Conformance
Page 1 of 3

The instrument identified below has been individually calibrated in compliance with the following standard(s):

IEEE 1309 - 2013, Institute of Electrical and Electronics Engineers, Standard for Calibration of Electromagnetic Field Sensors and Probes, Excluding Antennas from 9 kHz to 40 GHz

Environment: Laboratory MTE is maintained in a temperature controlled environment with ambient conditions from 18 to 28 C, relative humidity less than 90%. The instrument under test has been calibrated in a suitable environment using an EMCO TEM Cell 5101C, GTEM 5305/5402 and an RF Shielded EMC Chamber which is conducive to maintaining accurate and reliable measurement quality.

Manufacturer:	ETS-Lindgren	Operating Range:	100kHz - 5GHz
Model Number:	E100	Instrument Type:	Isotropic Probe > 1 GHz
Serial Number/ ID:	00126277	Date Code:	
Tracking Number:	S 000045944	Alternate ID:	
Date Completed:	01-Apr-19	Customer:	Motorola Solutions Malaysia Sdn Bhd (Innoplex) - Plot 2A, Medan Bayan Lepas, Mukim 12 SWD 11900 Bayan Lepas Penang, Malaysia. Bayan Lepas Penang 11900 Malaysia
Test Type:	Standard Field, Field Strength		

Calibration Uncertainty: Std Field Method 100kHz - 6 GHz, +/-0.64 dB, Linearity +/- 0.95 dB, Isotropy +/- 0.86
k=2, (95% Confidence Level)

Test Remarks: Probe received in tolerance thus before and after data are the same. Probe calibrated with customer's HI-2200 S/N: 00206805.

Calibration Traceability: All Measuring and Test Equipment (M/TE) identified below are traceable to the SI units through the National Institute for Standards and Technology (NIST) or other recognized National Metrology Institute. Calibration Laboratory and Quality System controls are compliant with ISO/IEC 17025-2005 and ANSI/NCSL Z540-1-1994.

Standards and Equipment Used:

Make / Model / Name / S/N / Recall Date				
HP	8648C	Signal Generator	3836U02236	18-Apr-19
Keysight	E9304A	Power Sensor	MY56100039	18-Apr-19
Hewlett Packard	E4422B	Signal Generator	US40050591	09-Aug-19
Agilent	E4419B	Power Meter	MY45104171	20-May-19
Rohde & Schwarz	SMB 100A	Signal Generator	101558	17-Sep-19
Agilent	E9304A	Power Sensor	MY41499013	18-Apr-19
Agilent	E9304A	Power Sensor	MY41499012	18-Apr-19
Rohde & Schwarz	NRP-Z91	Power Sensor	100734	18-Apr-19
Rohde & Schwarz	NRP-Z91	Power Sensor	100246	29-Jan-20
Agilent	N1913A	Power Meter	MY50000415	19-Feb-20
Marconi	2024	Signal Generator	112343/043	06-Apr-19
Rohde & Schwarz	NRVD	Power Meter	100451	01-Oct-19
Hewlett Packard	E4419B	Power Meter	US39250717	14-Aug-20
Keysight	E9304A	Power Sensor	MY56100005	18-Apr-19
Rohde & Schwarz	NRV-Z55	Thermal Power Sensor	100352	27-Jul-19
Rohde & Schwarz	NRV-Z55	Thermal Power Sensor	100037	28-Sep-19
Rohde & Schwarz	NRV-Z55	Thermal Power Sensor	100362	13-Dec-19
Rohde & Schwarz	NRP-Z91	Power Sensor	100732	19-Apr-19
Keysight	N5183B	MXG Analog Signal Gener	MY53270789	10-Jan-20

Condition of Instrument Upon Receipt:
In Tolerance to Internal Quality Standards
On Release:
In Tolerance to Internal Quality Standards

Julio Aquino
Calibration Completed By
Julio A. Aquino, Calibration Technician

George Cisneros
Attested and Issued on 01-Apr-19
George Cisneros, Calibration Supervisor

This document provides traceability of measurements to recognized national standards using controlled processes at the ETS-Lindgren Calibration Laboratory. Uncertainties listed are derived from the methods described by NIST Tech Note 1297. This certificate and report may not be reproduced, except in full, without the written approval of ETS-Lindgren Calibration Laboratory in accordance with ISO/IEC 17025-2005 and ANSI/NCSL Z540-1-1994. The results in this document relate only to the item(s) listed and should not be considered representative of a population unless otherwise noted. QAF 1127 (03/11)

CALIBRATION REPORT

Electric Field Sensor

<i>Model</i>	<i>S/N</i>
E100	00126277
HI-2200	00206805

Date: 01 Apr 2019

- New Instrument
- Other
- Out of Tolerance
- Within Tolerance

Frequency Response

<i>Frequency Response</i>	<i>MHz</i>	<i>Nominal Field</i> <i>V/m</i>	<i>Cal Factor*</i> <small>(Eapplied/Eindicated)</small>	<i>Deviation</i> <i>dB</i>
1	1	20	1.05	-0.44
2	15	20	1.01	-0.04
3	30	20	1.01	-0.06
4	75	20	1.01	-0.09
5	100	20	1.02	-0.13
6	150	20	1.01	-0.12
7	200	20	1.01	-0.06
8	250	20	1.01	-0.06
9	300	20	0.99	0.04
10	400	20	1.06	-0.47
11	500	20	0.94	0.54
12	600	20	0.93	0.63
13	700	20	1.00	0.04
14	800	20	1.01	-0.06
15	900	20	1.04	-0.32
16	1000	20	1.06	-0.52
17	2000	20	1.06	-0.48
18	2450	20	1.10	-0.84
19	3000	20	1.07	-0.62
20	3500	20	0.98	0.13
21	4000	20	1.07	-0.60
22	5000	20	1.41	-2.98
23	5500	20	1.40	-2.89
24	6000	20	1.56	-3.84

* Corrected electric field values (V/m) can be obtained by multiplying the Cal Factor with the indicated E field readings.

Linearity

maximum linearity deviation is 0.49 dB
(measurements taken from 0.3 V/m to 800 V/m at 27.12 MHz)

Test Conditions

Calibration performed at ambient room temperature: 23 ±3°C



PROBE ROTATIONAL RESPONSE

Model E100
S/N 00126277
Report S000045944
Date Date of Calibration 01 April 2019
Time 12:14:50 PM
Isotropy * + 0.292 dB/ -0.292 dB

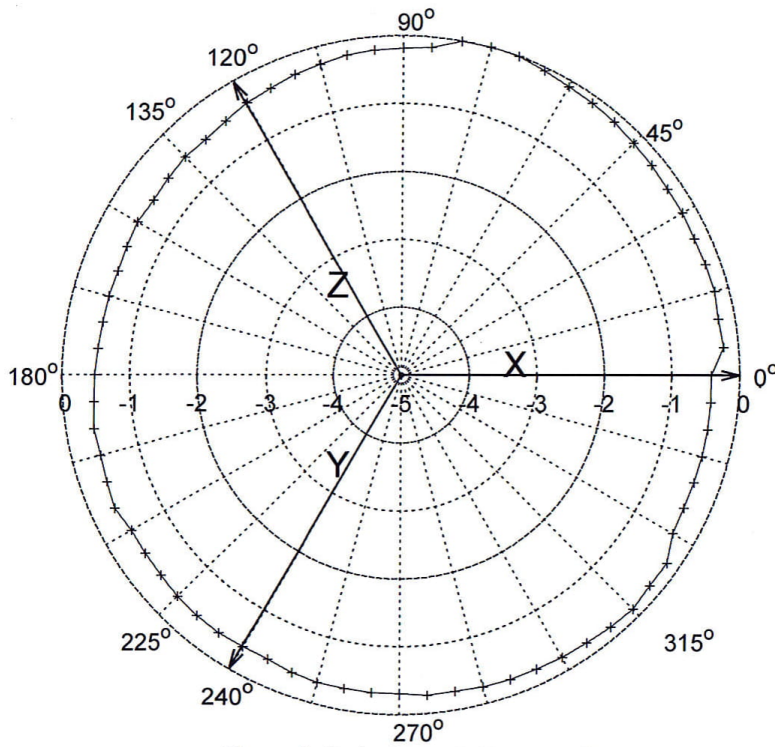

Figure 1: Probe Isotropic Response Chart.

Isotropic response is measured in a 20 V/m field at 400 MHz

*Isotropy is the maximum deviation from the geometric mean as defined by IEEE 1309-2013.



1301 Arrow Point Drive
Cedar Park, Texas 78613
(512) 531-6400

Cert I.D.: 129187

Certificate of Calibration Conformance

Page 1 of 2

The instrument identified below has been individually calibrated in compliance with the following standard(s):

IEEE 1309 - 2013, Institute of Electrical and Electronics Engineers, Standard for Calibration of Electromagnetic Field Sensors and Probes, Excluding Antennas from 9 kHz to 40 GHz

Environment: Laboratory MTE is maintained in a temperature controlled environment with ambient conditions from 18 to 28 C, relative humidity less than 90%. The instrument under test has been calibrated in a suitable environment using an EMCO TEM Cell 5101C, GTEM 5305/5402 and an RF Shielded EMC Chamber which is conducive to maintaining accurate and reliable measurement quality.

Manufacturer:	ETS-Lindgren	Operating Range:	5-300MHz / 30mA/m-10A/m
Model Number:	H200	Instrument Type:	Isotropic Magnetic Field Probe (2)
Serial Number/ ID:	00084225	Date Code:	
Tracking Number:	S 000045944	Alternate ID:	
Date Completed:	01-Apr-19	Customer:	Motorola Solutions Malaysia Sdn Bhd (Innoplex) - Plot 2A, Medan Bayan Lepas, Mukim 12 SWD 11900 Bayan Lepas Penang, Malaysia. Bayan Lepas Penang 11900 Malaysia
Test Type:	Standard Field, Field Strength		

Calibration Uncertainty: Direct Field Method 1.15dB
k=2, (95% Confidence Level)

Test Remarks: Probe received in tolerance thus before and after data are the same. Probe calibrated with customer's HI-2200 S/N: 00206805.

Calibration Traceability: All Measuring and Test Equipment (M/TE) identified below are traceable to the SI units through the National Institute for Standards and Technology (NIST) or other recognized National Metrology Institute. Calibration Laboratory and Quality System controls are compliant with ISO/IEC 17025-2005 and ANSI/NCSL Z540-1-1994.

Standards and Equipment Used:

Make / Model / Name / S/N / Recall Date				
HP 8648C	Signal Generator	3836U02236	18-Apr-19	
Keysight E9304A	Power Sensor	MY56100039	18-Apr-19	
Hewlett Packard E4422B	Signal Generator	US40050591	09-Aug-19	
Agilent E4419B	Power Meter	MY45104171	20-May-19	
Rohde & Schwarz SMB 100A	Signal Generator	101558	17-Sep-19	
Agilent E9304A	Power Sensor	MY41499013	18-Apr-19	
Agilent E9304A	Power Sensor	MY41499012	18-Apr-19	
Rohde & Schwarz NRP-Z91	Power Sensor	100734	18-Apr-19	
Rohde & Schwarz NRP-Z91	Power Sensor	100246	29-Jan-20	
Agilent N1913A	Power Meter	MY50000415	19-Feb-20	
Marconi 2024	Signal Generator	112343/043	06-Apr-19	
Rohde & Schwarz NRVD	Power Meter	100451	01-Oct-19	
Hewlett Packard E4419B	Power Meter	US39250717	14-Aug-20	
Keysight E9304A	Power Sensor	MY56100005	18-Apr-19	
Rohde & Schwarz NRV-Z55	Thermal Power Sensor	100352	27-Jul-19	
Rohde & Schwarz NRV-Z55	Thermal Power Sensor	100037	28-Sep-19	
Rohde & Schwarz NRV-Z55	Thermal Power Sensor	100362	13-Dec-19	
Rohde & Schwarz NRP-Z91	Power Sensor	100732	19-Apr-19	
Keysight N5183B	MXG Analog Signal Gener	MY53270789	10-Jan-20	

Condition of Instrument Upon Receipt:
In Tolerance to Internal Quality Standards
On Release:
In Tolerance to Internal Quality Standards

Julio Aquino
Calibration Completed By
Julio A. Aquino, Calibration Technician

George Cisneros
Attested and Issued on 01-Apr-19
George Cisneros, Calibration Supervisor

This document provides traceability of measurements to recognized national standards using controlled processes at the ETS-Lindgren Calibration Laboratory. Uncertainties listed are derived from the methods described by NIST Tech Note 1297. This certificate and report may not be reproduced, except in full, without the written approval of ETS-Lindgren Calibration Laboratory in accordance with ISO/IEC 17025-2005 and ANSI/NCSL Z540-1-1994. The results in this document relate only to the item(s) listed and should not be considered representative of a population unless otherwise noted. QAF 1127 (03/11)

CALIBRATION REPORT

Magnetic Field Sensor

<i>Model</i>	<i>S/N</i>
H200	00084225
HI-2200	00206805

Date: 01 Apr 2019

- New Instrument
- Other
- Out of Tolerance
- Within Tolerance

Frequency Response

<i>Frequency Response</i>	<i>MHz</i>	<i>Nominal Field</i> <i>A/m</i>	<i>Cal Factor*</i> <small>(Eapplied/Eindicated)</small>	<i>Deviation</i> <i>dB</i>
1	10	30	1.02	-0.16
2	15	30	0.99	0.12
3	30	30	0.96	0.34
4	50	30	0.95	0.43
5	75	30	0.93	0.62
6	100	30	0.90	0.89
7	150	30	0.84	1.51
8	175	30	0.80	1.89
9	200	30	0.76	2.38
10	250	30	0.65	3.77
11	300	30	0.53	5.50

* Corrected magnetic field values (A/m) can be obtained by multiplying the Cal Factor with the indicated H field readings.

Linearity

maximum linearity deviation is 0.37 dB
(measurements taken from 30 mA/m to 9 A/m at 27.12 MHz)

Test Conditions

Calibration performed at ambient room temperature: 23 ±3°C
The above sensor was calibrated to factory specifications. This calibration is performed per IEEE 1309 standard. All equipment used are traceable to US National Institute of Standards and Technology (NIST).

Appendix C - Photos of Assessed Antennas
(All antennas mounted to the vehicle with magnetic mount base)

APX 6500 VHF

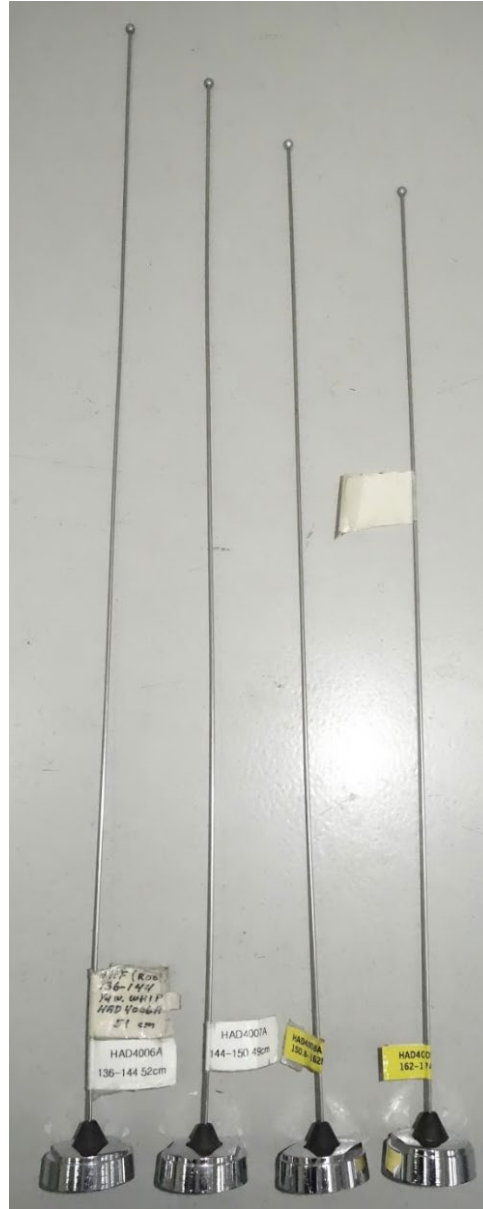

Antenna kit numbers: (From Left to Right)
HAD4006A, HAD4007A, HAD4008A, HAD4009A



**VHF Antenna kit numbers, from left to right
HAD4016A, HAD4017A, HAD4021A**

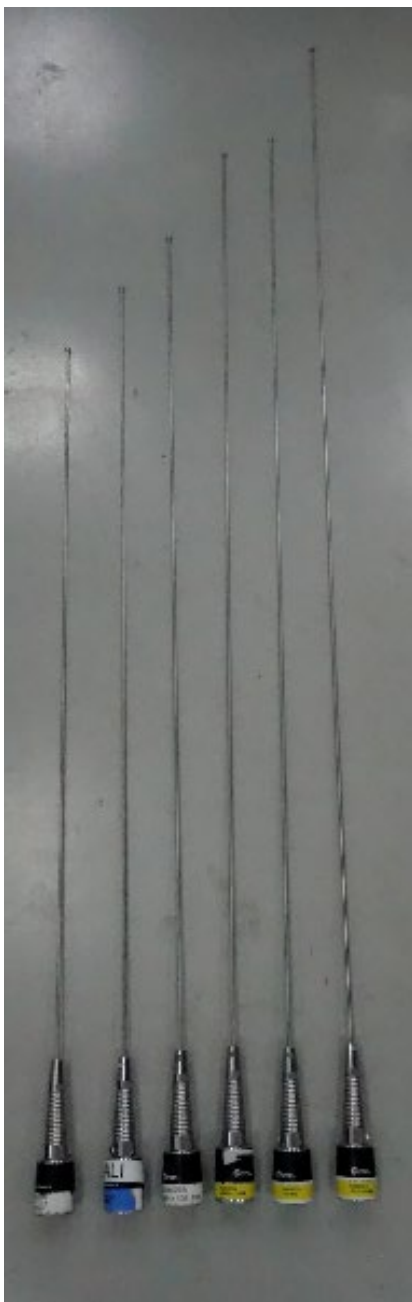

Antenna kit numbers: (From Left to Right)
HAD4022A (6 pcs)

Note: * Antenna length trimmed to frequency.

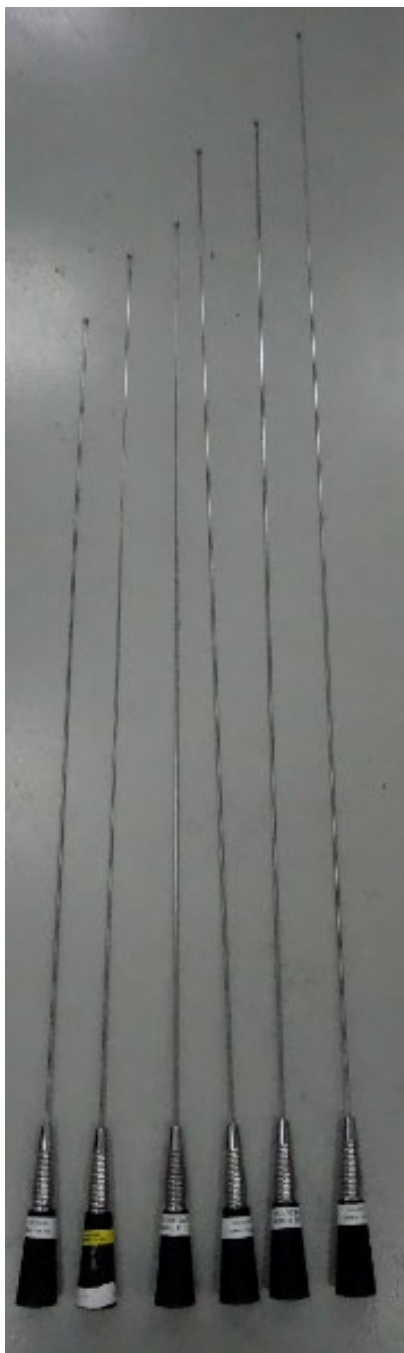

Antenna kit numbers:
RAD4010ARB (6 pcs)

Note: * Antenna length trimmed to frequency.

Companion Device (DVR 800)



Antenna kit number
HAF4016A