  <p>CERTIFICATE 2518.08</p> <p>MS ISO/IEC 17025 TESTING SAMM NO. 0825</p>
<p>MOTOROLA PENANG ADV. COMM. LABORATORY Motorola Solutions Malaysia SDN BHD, Plot 2A, Medan Bayan Lepas, Mukim 12 S.W.D, 11900 Bayan Lepas, Penang, Malaysia.</p>	<p>FCC TEST REPORT Report Revision : Rev.A</p>

<p>Date/s Tested : 24-NOV-2020 - 8-DEC-2020 Report Issue Date : 7-JAN-2021 Manufacturer : Motorola Solutions Inc. (Schaumburg) Manufacturer Address : Motorola Solutions Inc. 1301 E. Algonquin Road, Bldg II02 Room 3035 Schaumburg, Il 60196 Requestor : FEEMSTER MICHAEL Product Type : Mobile Product Version (PMN) : APX8500 Model Number (HVIN) : M37TXS9PW1AN (PHUW1001J) Frequency Band : 806-870MHz Max RF Output Power : 42 Watts Applicant Name : Motorola Solutions Inc Applicant Address : 8000 West Sunrise Boulevard, Fort Lauderdale, Florida 33322 ISED Registrations : MY0001 FCC Registrations : 461337 Firmware Version (FVIN) : R21.23.02</p>	
<p>The equipment was tested accordance to the requirement listed below:</p> <p>(LMR) FCC 47 CFR Part 2 / 90 ISED RSS- Gen Issue 5 / 119 Issue 12</p> <p style="text-align: right;">PASS</p>	

This report shall not be reproduced without written approval from an officially designated representative of the Motorola Penang Adv. Comm. Laboratory. The results and statements contained in this report pertain only to the device(s) evaluated.

<p>Prepared By:</p>  <p>Putri Nur Sarah Sofia Test Personnel</p>	<p>Approved Signatory:</p>  <p>Vincent Foong Chuen Kit Responsible Engineer</p>
--	---

Table of Contents

Report Revision History	3
1.0 General Information.....	4
2.0 Summary of Test Results	5
3.0 Measurement Uncertainty.....	6
4.0 Equipment List.....	6
5.0 Test Condition.....	9
5.1. Transmitter Test Conditions	9
6.0 Transmitter Test Parameters	10
6.1. RF Output Power	10
6.1.1. Test Setup.....	10
6.1.2. Test Result	10
6.2. Frequency Stability	11
6.2.1. Test Setup.....	11
6.2.2. Test Result	12
6.2.3. Test Limit.....	13
6.3. Audio Frequency Response	14
6.3.1. Test Setup.....	14
6.3.2. Test Result	14
6.3.3. Test Limit.....	14
6.4. Audio Low Pass Filter Response	15
6.4.1. Test Setup.....	15
6.4.2. Test Result	15
6.4.3. Test Limit.....	16
6.5. Modulation Limiting.....	17
6.5.1. Test Setup.....	17
6.5.2. Test Result	17
6.5.3. Test Limit.....	17
6.6. Occupied Bandwidth.....	18
6.6.1. Test Setup (Analog)	18
6.6.2. Test Result (Analog).....	18
6.6.3. Test Setup (Digital).....	19
6.6.4. Test Result (Digital).....	19
6.6.5. Test Limit.....	19
6.7. Band Edge Conducted Spurious Emission (Part 22)	20
6.7.1. Test Setup (Analog)	20
6.7.2. Test Result (Analog).....	20
6.7.3. Test Setup (Digital).....	20
6.7.4. Test Result (Digital).....	21
6.7.5. Test Limit.....	21
6.8. Transient Frequency Behavior.....	22
6.8.1. Test Setup.....	22
6.8.2. Test Result	22
6.8.3. Test Limit.....	23

6.9. Adjacent Channel Power..... 24

6.9.1. Test Setup (Analog) 24

6.9.2. Test Result 24

6.9.3. Test Setup (Digital)..... 25

6.9.4. Test Result 25

6.9.5. Test Limit..... 26

6.10. Conducted Spurious Emission 28

6.10.1. Test Setup..... 28

6.10.2. Test Result (Analog)..... 29

6.10.3. Test Result (Digital)..... 41

6.10.4. Test Limit..... 65

6.11. Radiated Spurious Emission 66

6.11.1. Test Setup..... 66

6.11.2. Test Result (Analog)..... 67

6.11.3. Test Result (Digital)..... 79

6.11.4. Test Limit..... 103

6.12. Effective Radiated Power (ERP) 104

6.12.1. Test Setup..... 104

6.12.2. Test Result 104

6.12.3. Test Limit..... 104

6.13. GNSS (EIRP for 1559 - 1610MHz)..... 105

6.13.1. Test Setup..... 105

6.13.1. Test Result 105

6.13.2. Test Limit..... 105

Report Revision History

Revision History	Description	Date	Originator
Rev. A	Initial Report	9-DEC-2020	Putri Nur Sarah Sofia

1.0 General Information

EUT Description:

Technologies	Land Mobile Radio (LMR)
Modulation Type	Analog, C4FM, Phase II

The EUT contains following accessory devices and data cable:

Item	Brand	Model or P/N
KEYPAD MICROPHONE	Motorola	HMN4079G
USB CABLE, MAP CONNECTOR (6 FT)	Motorola	HKN6163C
10 CAN CABLE REMOTE MOUNT	Motorola	HKN6170B
REMOTE CONTROL HEAD POWER AND SPEAKER	Motorola	HKN6188B
Control Head 07	Motorola	PMHN4194A
O2/O7 REMOTE CHIB	Motorola	PMUN1057B

General Description of Applied Standards

The EUT is a RF Product. According to the specifications of the manufacturer, the EUT is to comply with the requirements of the following standards:

ANSI C63.4-2014

ANSI C63.26-2015

No modifications were done to the UUT to facilitate the tests in this report.

Deviation from standard

Not applicable as no deviation from standard test method

Selection of test modes

Some reports may contain a limited number of test points/modes, in which case all channels and modulations were evaluated and the worst case performance is presented in the report

2.0 Summary of Test Results

FCC General Rules Part (47CFR)	ISED General Rules Part	Test Item	Result	Remarks	Serial number tested
2.1046, 90.541	RSS-119	RF Power Output	Pass		G0P0WP0AVC
2.1055	RSS-119	Frequency Stability	Pass		G0P0WP0AVC
-	-	Audio Frequency Response	NA		
-	-	Audio Low Pass Filter Response	NA		
-	-	Modulation limiting	NA		
-	-	Occupied Bandwidth	NA		
-	-	Band Edge Conducted Spurious Emission	NA		
-	-	Transient Frequency Behavior	NA		
-	-	Adjacent Channel Power	NA		
90.210	RSS-119	Conducted Spurious Emissions	Pass	Highest spur : -24.06dBm	G0P0WP0AVC
90.210	RSS-119	Radiated Spurious Emission	Pass	Highest spur : -33.14dBm	PHUW1001H-CF2
-	-	GNSS (EIRP for 1559 – 1610MHz)	NA		
-	-	Effective Radiated Power (ERP)	NA		

NA → Not Applicable

3.0 Measurement Uncertainty

Measurement	Frequency	Expended Uncertainty (k=1.96) (±)
AC Power Line Conducted Spurious Emission	150KHz ~ 30MHz	3.43 dB
Radiated Emissions up to 1 GHz	30MHz ~ 200MHz	4.25 dB
	200MHz ~ 1000MHz	4.25 dB
Radiated Emissions above 1 GHz	1GHz ~ 18GHz	4.94 dB
	18GHz ~ 25GHz	4.94 dB
Conducted Spurious Emissions	9kHz ~ 12.75GHz	2.82 dB
Frequency Stability	9kHz ~ 12.75GHz	0.0085 ppm
Audio Frequency Response / Low Pass Filter Response	300Hz – 20kHz	4.09 %
Modulation Limiting	300Hz – 3kHz	1.15 %
Occupied Bandwidth	9kHz ~ 12.75GHz	2.82 dB
Band Edge Conducted Spurious Emission	9kHz ~ 12.75GHz	2.82 dB
Transient Frequency Behavior	9kHz ~ 12.75GHz	5.4 ms
Adjacent Channel Power	9kHz ~ 12.75GHz	2.82 dB

4.0 Equipment List

FCC Analog ATE#1: (SW version: 2.4.6 & FCC_Frequency Stability 1.0.3 rev.)

Description	Model	Serial Number	Calibration Date	Calibration Due Date
CHAMBER	SH-641	92009188	06-Mar-20	06-Mar-21
DSA Dynamic Signal Analyzer	35670A	MY42507095	19-Jun-20	19-Jun-21
ANALYZER AUDIO	8903B	3514A15797	29-Oct-20	29-Oct-21
POWER METER	E4416A	MY45102699	26-Jun-20	26-Jun-21
POWER SENSOR	E9301B	MY41498918	12-Aug-20	12-Aug-21
POWER SUPPLY	6031A	3325A02771	13-Mar-20	13-Mar-21
SIGNAL GENERATOR	2042	119718/063	24-Jun-20	24-Jun-21
ANALYZER MODULATION	8901B	3122A03662	08-Jul-20	08-Jul-21
N to N RF Cable # 1	M17/128-RG400	NA	NA	NA
BNC to N RF Cable # 1	RG 58	NA	NA	NA
BNC to BNC RF Cable # 1	RG 58	NA	NA	NA
BNC to BNC RF Cable # 2	RG 58	NA	NA	NA
BNC to BNC RF Cable # 3	RG 58	NA	NA	NA
BNC to BNC RF Cable # 4	RG 58	NA	NA	NA
BNC to BNC RF Cable # 5	RG 58	NA	NA	NA
BNC to BNC RF Cable # 6	RG 58	NA	NA	NA
BNC to BNC RF Cable # 7	RG 58	NA	NA	NA
N to SMA RF Cable # 1	RG 58	NA	NA	NA
N to SMA RF Cable # 2	RG 58	NA	NA	NA
N to SMA RF Cable # 3	RG 58	NA	NA	NA
Aeroflex Attenuator 30dB	49-30-34-LIM	NA	NA	NA

FCC Transient ATE #1: (SW version: FCC Transient ATE_R1.1.3)

Description	Model	Serial Number	Calibration Date	Calibration Due Date
SWITCH CONTROL UNIT	3488A	2719A36210	CNR	CNR
ATTENUATOR / SWITCH DRIVER	11713A	2508A10141	CNR	CNR
POWER METER	E4416A	GB41293866	26-Feb-19	26-Feb-21
POWER SUPPLY	6032A	MY41002067	22-Feb-20	22-Feb-21
SIGNAL GENERATOR	8657A	3250A05137	19-Jun-20	19-Jun-21
STEP ATTENUATOR	8494G	MY42143006	12-Jun-20	12-Jun-21
STEP ATTENUATOR	8496G	MY42143012	13-Jun-20	13-Jun-21
OSCILLOSCOPE	MSO8104A	MY45002372	26-Jun-20	26-Jun-21
ANALYZER MODULATION	8901B	3438A05093	23-Jun-20	23-Jun-21
ANALYZER AUDIO	8903B	3011A12671	11-Mar-20	11-Mar-21
ANALYZER AUDIO	8903B	3011A08952	29-Jul-20	29-Jul-21
SPECTRUM ANALYZER	E4440A	MY46181974	2-Aug-20	2-Aug-21
N to N RF Cable # 1	SF126/11N/11N	NA	NA	NA
N to N RF Cable # 2	M17/128-RG400	NA	NA	NA
N to N RF Cable # 3	M17/128-RG400	NA	NA	NA
N to N RF Cable # 4	M17/128-RG400	NA	NA	NA
N to N RF Cable # 5	M17/128-RG400	NA	NA	NA
N to N RF Cable # 6	M17/128-RG400	NA	NA	NA
N to N RF Cable # 7	M17/128-RG400	NA	NA	NA
N to N RF Cable # 8	M17/128-RG400	NA	NA	NA
N to N RF Cable # 9	M17/128-RG400	NA	NA	NA
BNC to BNC RF Cable # 1	RG 58	NA	NA	NA
BNC to BNC RF Cable # 2	RG 58	NA	NA	NA
BNC to BNC RF Cable # 3	RG 58	NA	NA	NA
BNC to BNC RF Cable # 4	RG 58	NA	NA	NA
BNC to BNC RF Cable # 5	RG 58	NA	NA	NA
BNC to BNC RF Cable # 6	RG 58	NA	NA	NA
BNC to N RF Cable # 1	RG 58	NA	NA	NA
Aeroflex Attenuator 10dB	49-10-43-LIM	NA	NA	NA
Aeroflex Attenuator 10dB	33-10-34-LIM	NA	NA	NA
SWITCH CONTROL UNIT	3488A	2719A36210	CNR	CNR

CONDUCTED SPUR EMISSION ATE # 1 (SW version: Conducted Spur ATE_rev 1.23.03)

Description	Model	Serial Number	Calibration Date	Calibration Due Date
SWITCH CONTROL UNIT	3488A	2719A32735	CNR	CNR
ANALYZER SPECTRUM	E4440A	MY46185415	10-Jan-20	10-Jan-22
POWER SUPPLY	6031A	3543A03489	05-Jun-20	05-Jun-21
HIGH PASS FILTER SWITCH BOX	-	CS001	2-Jul-20	2-Jul-21
N to N RF Cable # 1	SF126/11N/11N	NA	NA	NA
N to N RF Cable # 2	SF126/11N/11N	NA	NA	NA
BNC to BNC RF Cable # 1	RG 58	NA	NA	NA
Aeroflex Attenuator 30dB	49-30-43-LIM	NA	NA	NA
Aeroflex Attenuator 10dB	33-10-34-LIM	NA	NA	NA

EMC Chamber 1

DESCRIPTION	MODEL	SERIAL NUMBER	CALIBRATION DATE	CALIBRATION DUE DATE
DRG HORN FREQ.	SAS-571	720	21-Mar-19	21-Mar-21
DRG HORN FREQ.	SAS-571	1143	14-Feb-19	14-Feb-21
POWER SUPPLY	6032A	2615A01178	21-May-20	21-May-21
SIGNAL GENERATOR	SMB 100A	181117	8-Nov-18	8-Nov-21
EMI TEST RECEIVER	ESW44	101731	3-Dec-19	3-Feb-21
EMI TEST RECEIVER	ESIB26	100017	19-Jul-19	19-Jan-21
5m SEMI-ANECHOIC CHAMBER	S800-HX	J2308	No Cal. Req'd	No Cal. Req'd
BILOG ANTENNA	CBL6112B	2964	23-Apr-19	23-Apr-21
BILOG ANTENNA	CBL6112B	2950	8-Jul-19	8-Jul-21
DATA LOGGER	SDL500	A.016776	4-Jun-20	4-Jun-21
SYSTEM CONTROLLER	SC104V	050806-1	CNR	CNR
TURNTABLE FLUSH MOUNT 2M	FM2011	NA	CNR	CNR
ANTENNA POSITIONING TOWER	TLT2	NA	CNR	CNR
BROAD-BAND HORN ANTENNA	BBHA9170	BBHA9170255	27-Jan-20	27-Jan-21
18 - 40GHz PREAMPLIFIER	MITEQ Hi GAIN SUCOFLEX	001	CNR	CNR
PREAMPLIFIER	PAM-0118	269	24-May-19	24-May-22
LOOP ANTENNA	6502	00203479	21-Jan-20	21-Jan-21
TEST SOFTWARE	EMC FCC IC BLUETOOTH RE TEST			
VERSION	EMC FCC RE v1.6.2			

5.0 Test Condition

5.1. Transmitter Test Conditions

Test Item, (Channel Spacing)	Power (W)	Modulation	Test Frequency (MHz)	Tested By	Environmental conditions
RF Output Power	Low & Max	Analog	806.0125, 814.9875, 823.9875, 851.0125, 860.0125, 868.8875	Putri	23.4°C, 50%RH
Frequency Stability	Max	Analog	823.9875	Putri	25.1°C, 54.3%RH, 60.3°C, 50%RH, -30.1°C, 51.2%RH
Audio Frequency Response (12.5kHz / 25kHz)	Max	Analog	NA		
Audio Low Pass Filter Response (12.5kHz / 25kHz)	Max	Analog	NA		
Modulation limiting (12.5kHz / 25kHz)	Max	Analog	NA		
Occupied Bandwidth (12.5kHz / 20kHz / 25kHz)	Max	Analog, C4FM, Phase II	NA		
Band Edge Conducted Spurious Emissions (Part 22) (12.5kHz / 20kHz / 25kHz)	Low / Max	Analog, C4FM, Phase II	NA		
Transient Frequency Behavior (UHF & VHF Band) (12.5kHz / 25kHz)	Max	Analog, C4FM, Phase II	NA		
Adjacent Channel Power (700MHz Band) (12.5kHz / 25kHz)	Max	Analog, C4FM, Phase II	NA		
Conducted Spurious Emissions- (12.5kHz / 25kHz)	Low / Max	Analog, C4FM, Phase II	806.0125, 814.9875, 823.9875, 851.0125, 860.0125, 868.8875	Putri	23.4°C, 50%RH
Radiated Spurious Emission (12.5kHz / 25kHz)	Low / Max	Analog, C4FM, Phase II	806.0125, 814.9875, 823.9875, 851.0125, 860.0125, 868.8875	Nazrin&Fendi	23.9°C, 69.9%RH
GNSS (EIRP for 1559 - 1610MHz) (12.5kHz / 25kHz)	Max	Analog	NA		
Effective Radiated Power (ERP) (12.5kHz / 25kHz)	Max	Analog	NA		

NA → Not Applicable

6.0 Transmitter Test Parameters

6.1. RF Output Power

6.1.1. Test Setup

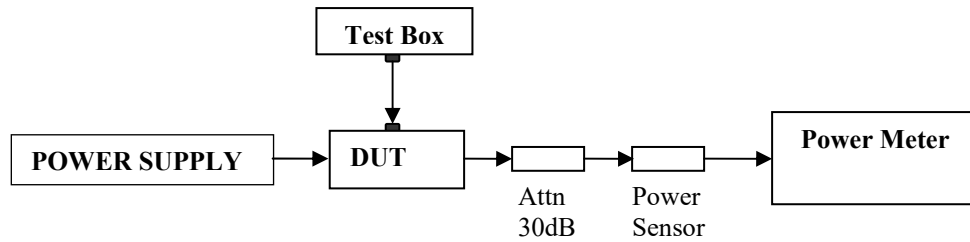

- 1) The DUT transmitter connected to Power Meter using the 30 dB attenuator and power sensor with above setup.
- 2) Path loss for the measurement included.
- 3) All the measurement was done at low, mid, high frequency for each band.
- 4) Record the power into the test report.

6.1.2. Test Result

Temperature	25°C			
Voltage (V)	13.6V			
Frequency (MHz)	Low Power (W)	Current (A)	Max Power (W)	Current (A)
806.0125	1.01	3.33	41.50	12.06
814.98750	1.00	3.33	41.40	12.02
823.98750	1.00	3.33	41.60	12.21
851.01250	1.01	3.42	41.90	12.54
860.01250	1.01	3.36	41.90	12.36
868.88750	1.01	3.36	41.90	12.15

6.2. Frequency Stability

6.2.1. Test Setup

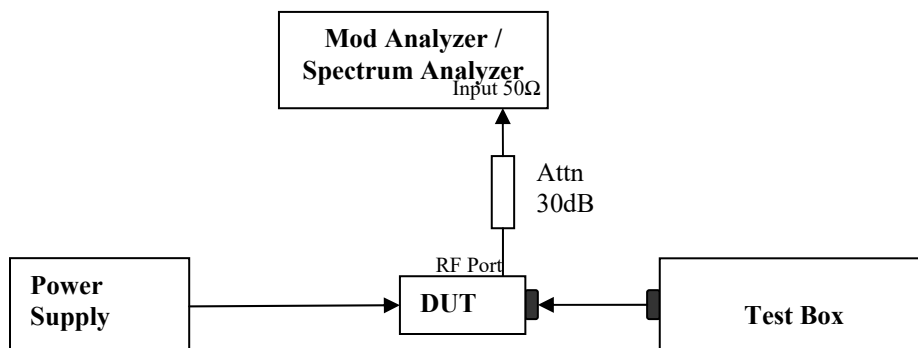

- 1) The DUT transmitter output port was connected to Modulation / Spectrum Analyzer.
- 2) Path loss for the measurement included.
- 3) Transmit the DUT and record the freq in MCF_{MHz} .
- 4) Test in 2 conditions:
 - Temperature: The frequency of the transmitter was measured from -30°C to 50°C.
 - Supply Voltage:
 - Mobile: The frequency of the transmitter was measured from 85% to 115% of the nominal operating input voltage.
 - Portable: The frequency of the transmitter was measured from nominal $\pm x\%$ as specified by the manufacturer
- 5) Calculate the ppm frequency error by the following:

$$ppm\ error = \left(\frac{MCF_{MHz}}{ACF_{MHz}} - 1 \right) * 10^6$$

Where: MCF_{MHz} is the Measured Carrier Frequency in MHz
 ACF_{MHz} is the Assigned Carrier Frequency in MHz

6.2.2. Test Result

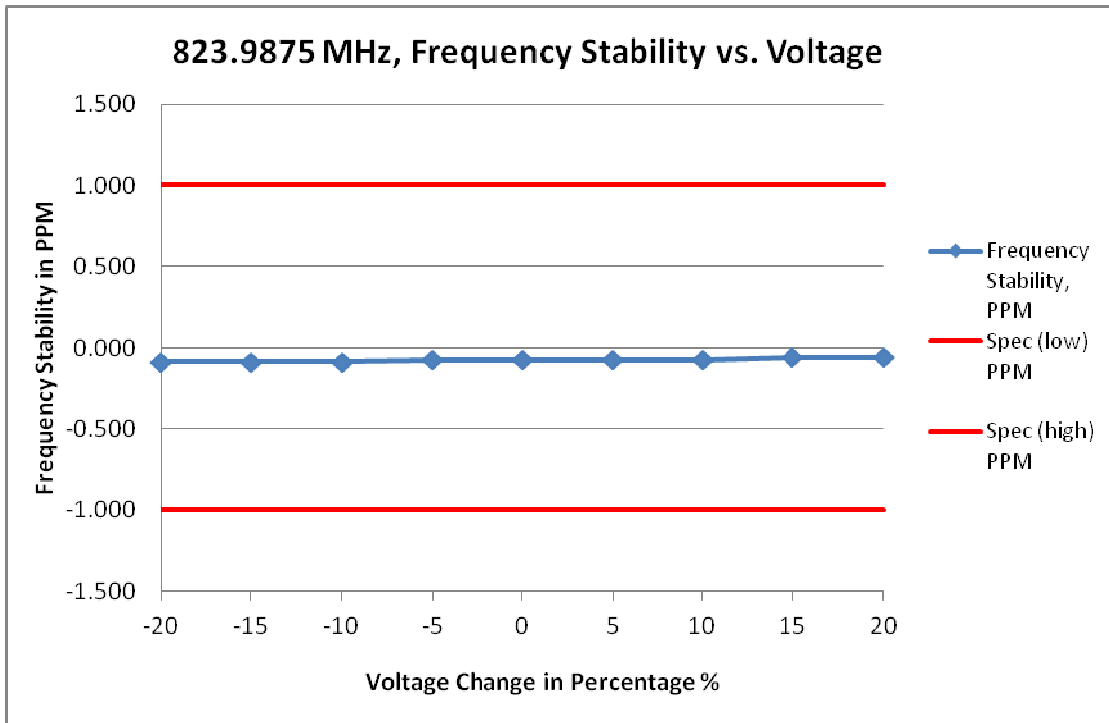

(i) Frequency Stability VS Voltage

Frequency / Channel Spacing	823.9875 MHz / 12.5 kHz				
Temperature, °C	25				
Voltage %	Voltage, V	Frequency, MHz	Frequency Stability, PPM	Spec (low) PPM	Spec (high) PPM
-20	11.560	823.987430	-0.085	-1.000	1.000
-15	12.240	823.987430	-0.085	-1.000	1.000
-10	12.920	823.987430	-0.085	-1.000	1.000
-5	13.600	823.987440	-0.073	-1.000	1.000
0	14.280	823.987440	-0.073	-1.000	1.000
5	14.960	823.987440	-0.073	-1.000	1.000
10	15.640	823.987440	-0.073	-1.000	1.000
15	16.320	823.987450	-0.061	-1.000	1.000
20	16.320	823.987450	-0.061	-1.000	1.000

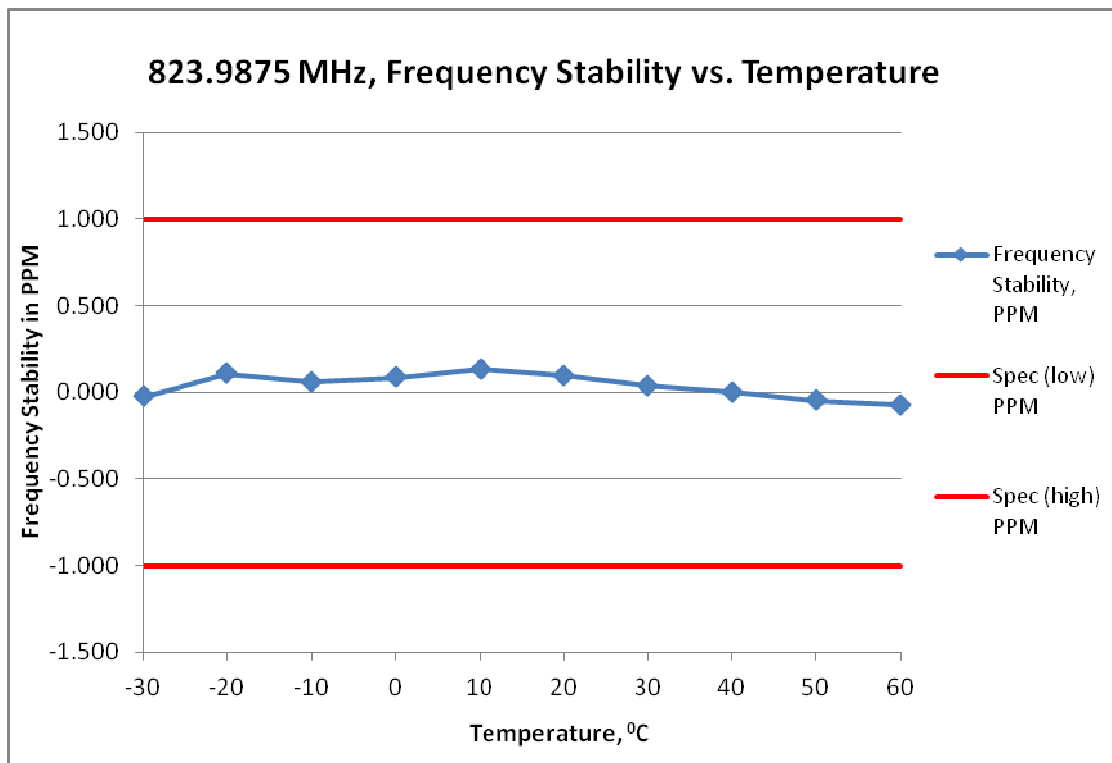

(ii) Frequency Stability VS temperature

Frequency / Channel Spacing	823.9875 MHz / 12.5 kHz			
Voltage, V	13.6			
Temperature, °C	Frequency, MHz	Frequency Stability, PPM	Spec (low) PPM	Spec (high) PPM
-30	823.987480	-0.024	-1.000	1.000
-20	823.987590	0.109	-1.000	1.000
-10	823.987550	0.061	-1.000	1.000
0	823.987570	0.085	-1.000	1.000
10	823.987610	0.133	-1.000	1.000
20	823.987580	0.097	-1.000	1.000
30	823.987530	0.036	-1.000	1.000
40	823.987500	0.000	-1.000	1.000
50	823.987460	-0.049	-1.000	1.000
60	823.987440	-0.073	-1.000	1.000

6.2.3. Test Limit

As per manufacturer declared spec +/- 1.0ppm

6.3. Audio Frequency Response

6.3.1. Test Setup

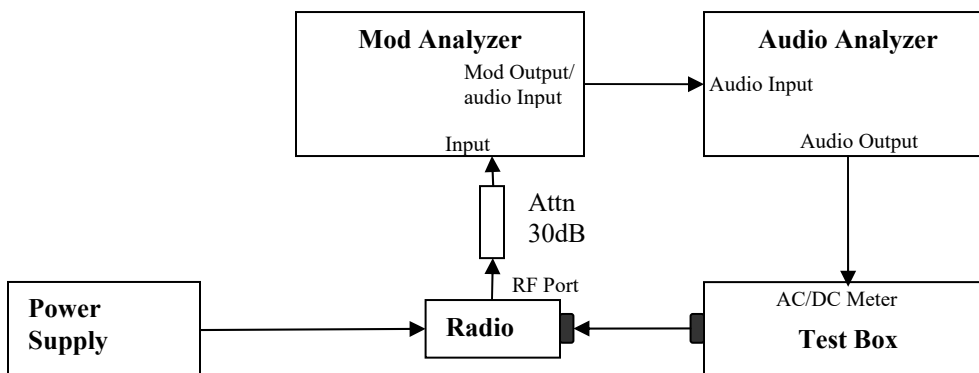

- 1) The DUT transmitter output port was connected to Modulation Analyzer.
- 2) Path loss for the measurement included.
- 3) Set the audio bandwidth filter to 15 kHz and 50 kHz.
- 4) Transmit the radio and set the audio analyzer to 1 kHz audio frequency and 20% of the Full rated system deviation.
- 5) On audio analyzer, set the rated level as reference to zero.
- 6) Vary the audio frequency from 300 Hz to 3 kHz. Record the change in dB on the audio analyzer.

6.3.2. Test Result

Not Applicable.

6.3.3. Test Limit

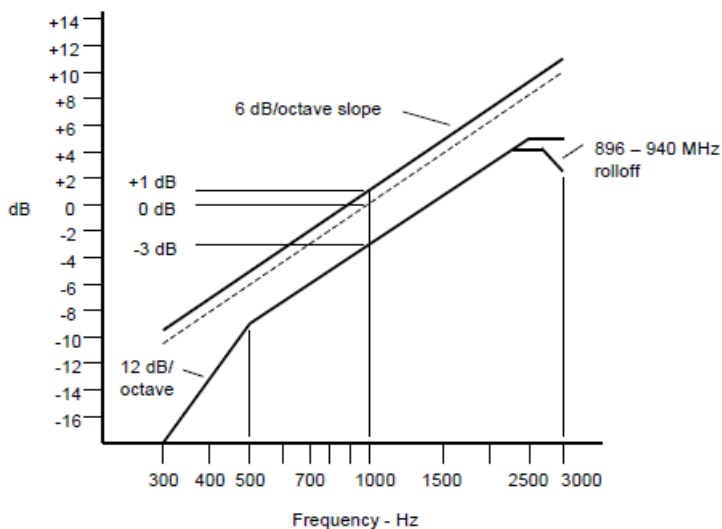

Note:

- o There are additional 6 dB per octave attenuation is allowed from 2.5KHz to 3KHz in equipment 25MHz to 869MHz radio.
- o Additional 6 dB per octave attenuation is allowed from 2.3KHz to 2.7KHz & additional 12 dB per octave attenuation is allowed from 2.7KHz to 3KHz in equipment 896MHz to 940MHz radio.

6.4. Audio Low Pass Filter Response

6.4.1. Test Setup

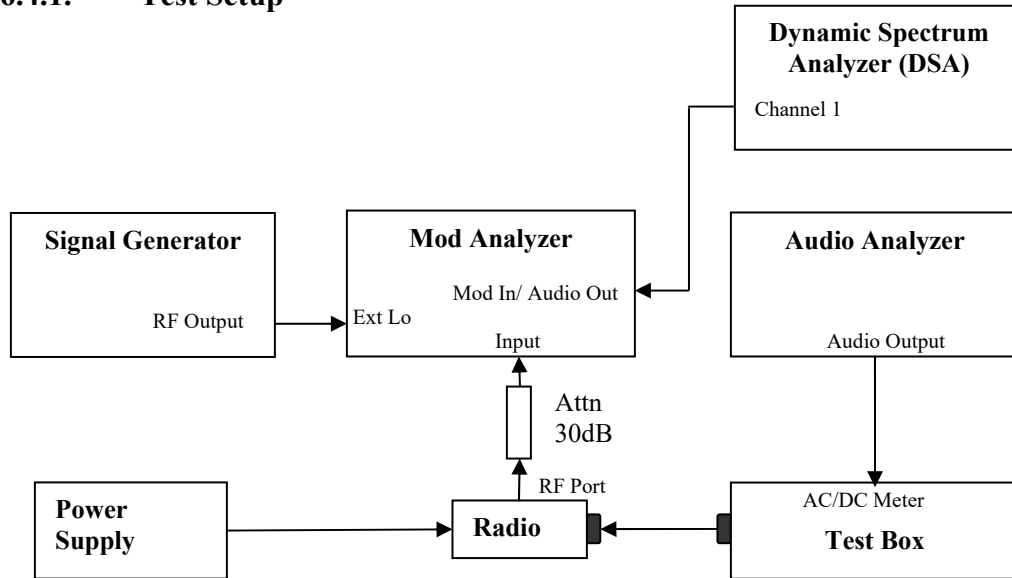

- 1) The DUT transmitter output port was connected to Modulation Analyzer.
- 2) Path loss for the measurement included.
- 3) Press 23.1SPCL on modulation analyzer to enable the external LO from Sigen.
- 4) Set the Sigen frequency to $F_c + 1.5$ MHz, RF output level to 0dBm without modulation.
- 5) Transmit the radio and set the audio analyzer to 1 kHz audio frequency and 60% of the Full rated system deviation.
- 6) Up the amplitude by 20dB.
- 7) On DSA, get the reference point to 0dB.
- 8) Vary the frequency on audio analyzer from 3 kHz to 20 kHz, record the audio tone from DSA.

6.4.2. Test Result

Not Applicable.

6.4.3. Test Limit

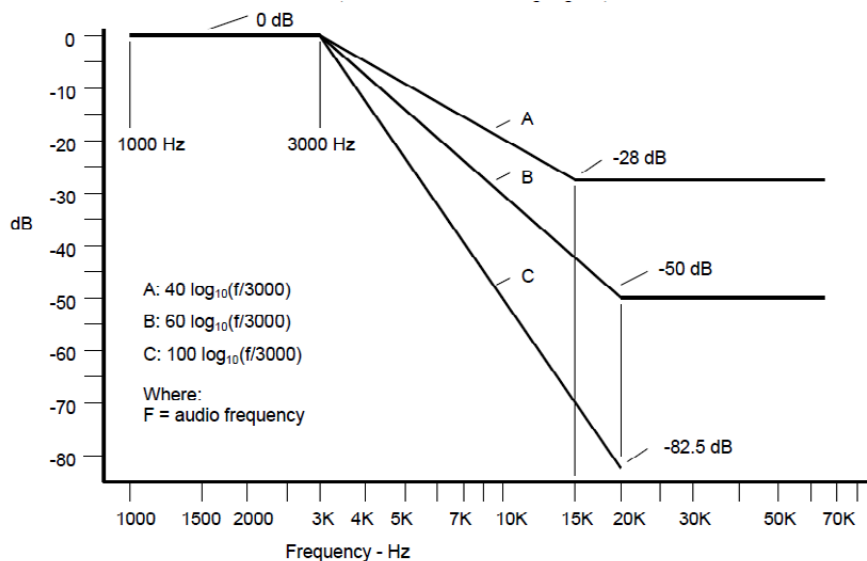

For audio frequencies above 3000 Hz, the audio response of the post limiter low-pass filter shall meet or exceed the following requirements:

- a) For equipment operating on 20, 25 or 30 kHz channel bandwidth in the 25 MHz to 174 MHz range:

At frequencies from 3000 Hz through 15,000 Hz the attenuation shall be greater than the attenuation at 1000 Hz by at least: $40 \log_{10}(f/3000)$ dB

where: f is the audio frequency in Hz.

At frequencies above 15,000 Hz, the attenuation shall be greater than the attenuation at 1000 Hz, by at least: 28 dB.

- b) For equipment operating with 25 kHz bandwidth channels between 406 and 512 MHz through 896 MHz, and between 929 MHz through 930 MHz:

At frequencies from 3000 Hz through 20,000 Hz, the attenuation shall be greater than the attenuation at 1000 Hz by at least: $60 \log_{10}(f/3000)$ dB

where: f is the audio frequency in Hz.

At frequencies above 20,000 Hz the attenuation shall be greater than the attenuation at 1000 Hz by at least: 50 dB.

- c) For equipment operating on channels between 896 MHz through 901 MHz, between 935 MHz through 940 MHz, and 12.5 or 15 kHz spaced channels in the frequency range 138-174 MHz and 406-512 MHz.

At frequencies from 3000 Hz through 20,000 Hz the attenuation shall be greater than the attenuation at 1000 Hz by at least: $100 \log_{10}(f/3000)$ dB

where: f is the audio frequency in Hz.

6.5. Modulation Limiting

6.5.1. Test Setup

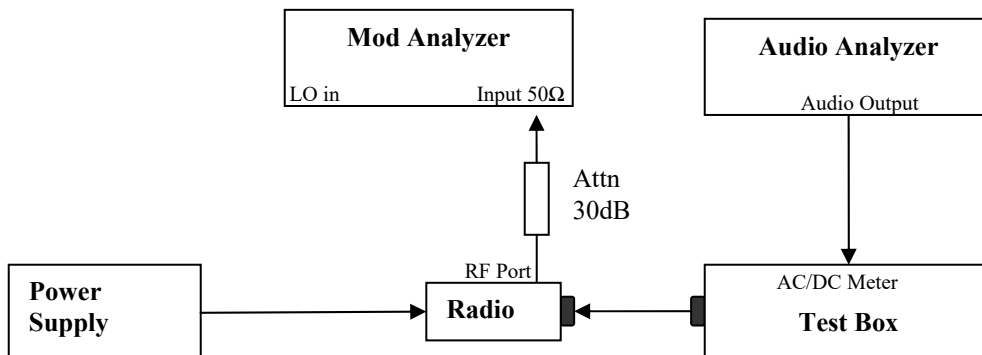

- 1) The DUT transmitter output port was connected to Modulation Analyzer.
- 2) Path loss for the measurement included.
- 3) Set the audio bandwidth filter to 15 kHz.
- 4) Transmit the radio and set the audio analyzer to 1 kHz audio frequency and 60% of the Full rated system deviation.
- 5) Record the frequency deviation as 0dB input level at 1kHz audio frequency.
- 6) Repeat the step and record the frequency deviation from -20 dB to 20dB by 5 dB increments and different audio freq 300 Hz, 2.5 kHz and 3 kHz.

6.5.2. Test Result

Not Applicable.

6.5.3. Test Limit

Modulation Limiting shall not exceed 100 percent.

6.6. Occupied Bandwidth

6.6.1. Test Setup (Analog)

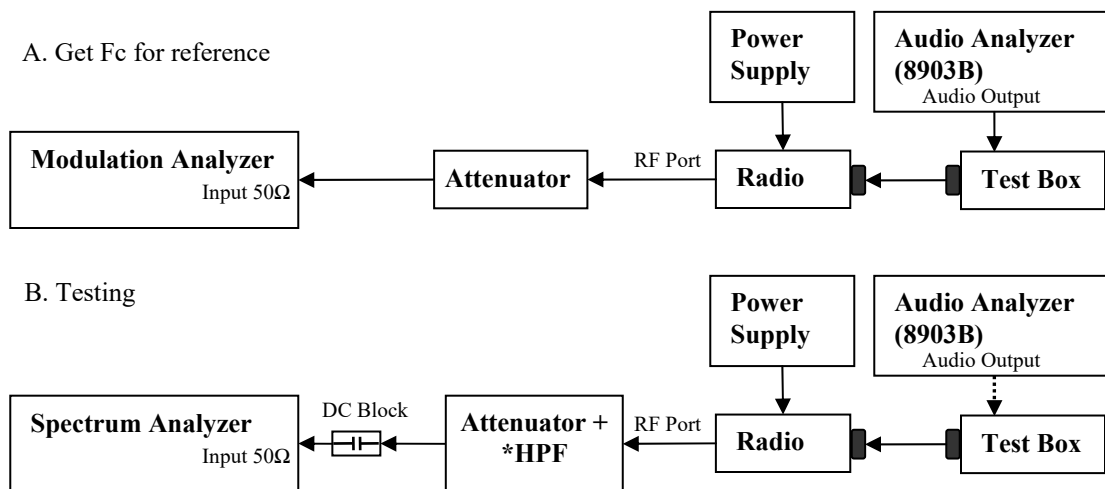

- 1) The DUT transmitter output port was connected to Modulation Analyzer.
- 2) Set the audio bandwidth filter to 15 kHz low pass filter and 50 kHz high pass filter.
- 3) Transmit the radio and set the audio analyzer to 2.5 kHz audio frequency and 50% of the rated deviation. Up the amplitude by 16 dB. Dekey the DUT.
- 4) Path loss for the measurement included.
- 5) Select the Occupied Bandwidth measurement for 99% Emissions Bandwidth Measurement.
- 6) Key in the Fc and Resolution Bandwidth (1 ~ 5 % of emission designator).
- 7) Transmit the DUT and record the occupied Bandwidth frequency.
- 8) Preset the spectrum analyzer for sideband spectrum measurement.
- 9) Set the span and Resolution Bandwidth (according to FCC/ ISED standard).
- 10) Save the screen shot as modulated signal
- 11) Remove the audio tone from audio analyzer to capture unmodulated signal.

* Only HPF added for Mask 80.211 measurement with attenuator.

6.6.2. Test Result (Analog)

Not Applicable.

6.6.3. Test Setup (Digital)

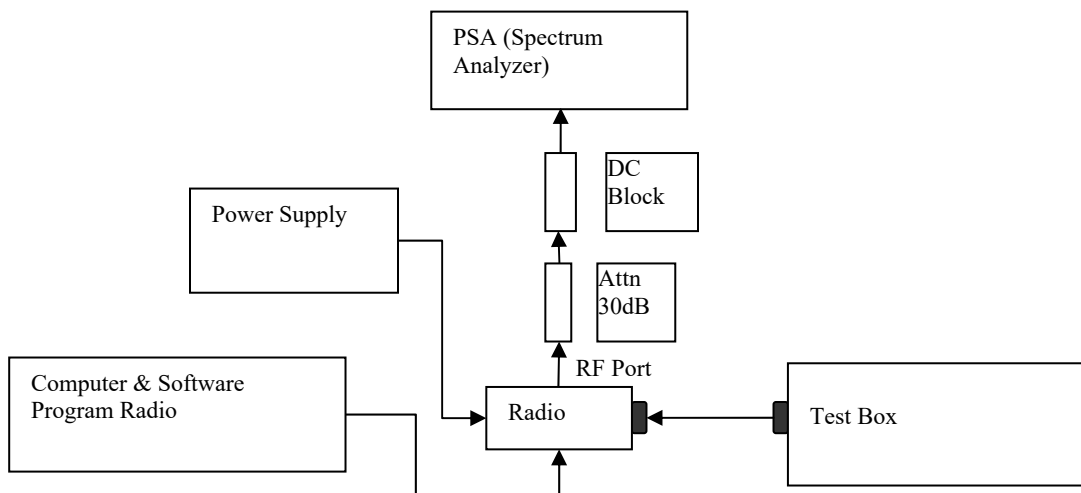

- 1) Program and set radio to operate in desire test frequency and digital mode with modulation. (*4FSK, C4FM or other digital modulation form).
- 2) Path loss for the measurement included.
- 3) Select the Occupied Bandwidth measurement for 99% Emissions Bandwidth Measurement.
- 4) Key in the Fc and Resolution Bandwidth (1 ~ 5 % of emission designator).
- 5) Transmit the DUT and record the occupied Bandwidth frequency.
- 6) Preset the spectrum analyzer for modulation emission spectrum measurement.
- 7) Set the span and Resolution Bandwidth (according to FCC/ ISED standard).
- 8) Capture the screen shot as modulated signal.

*Note:

- For Digital Modulation, 12.5 kHz Data F1D & FXD would be the same. Therefore only measurements with F1D modulation shown below.
- For Digital Modulation, 12.5 kHz Data F1E & FXE would be the same. Therefore only measurements with F1E modulation shown below.

6.6.4. Test Result (Digital)

Not Applicable.

6.6.5. Test Limit

The 99% occupied bandwidth is the width of a frequency band such that, below the lower and above the upper frequency limits, the mean powers emitted are each equal to a specified percentage 0.5% of the total mean transmitted power.

6.7. Band Edge Conducted Spurious Emission (Part 22)

6.7.1. Test Setup (Analog)

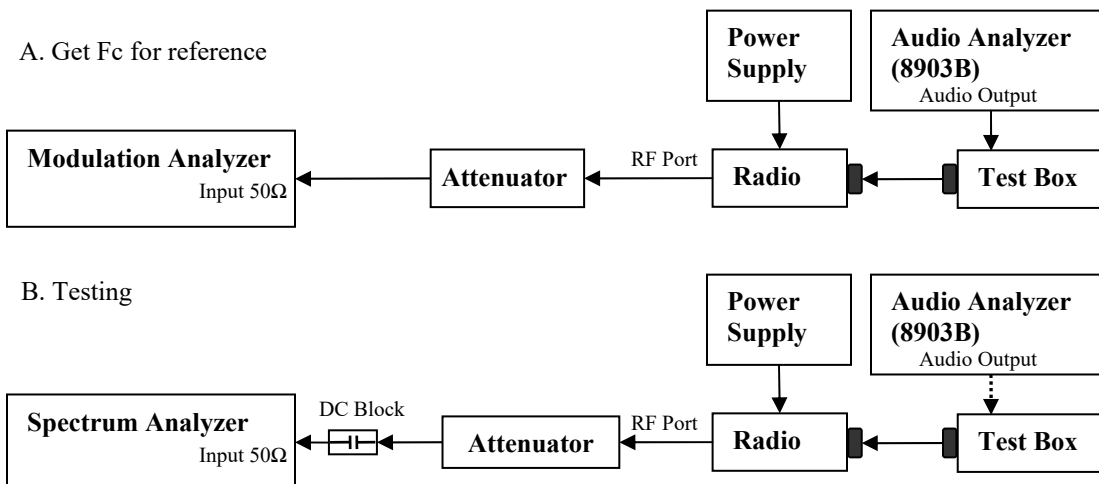

- 1) The DUT transmitter output port was connected to Modulation Analyzer.
- 2) Set the audio bandwidth filter to 15 kHz low pass filter and 50 kHz high pass filter.
- 3) Transmit the radio and set the audio analyzer to 2.5 kHz audio frequency and 50% of the rated deviation. Up the amplitude by 16 dB. Dekey the DUT.
- 4) Path loss for the measurement included.
- 5) Select the Occupied Bandwidth measurement for 99% and 26dB Emissions Bandwidth Measurement.
- 6) Key in the Fc and Resolution Bandwidth.
- 7) Transmit the DUT and record the occupied Bandwidth frequencies.
- 8) Preset the spectrum analyzer for band edge measurement.
- 9) The band edges of lowest and highest channels were measured.
- 10) Key in the Lowest and highest channel frequency, span is 60 kHz and Resolution Bandwidth is at least 1% of Emission Bandwidth.
- 11) Save the screen shot as modulated signal.
- 12) Remove the audio tone from audio analyzer to capture unmodulated signal.

*Note:

- For emission designator ending with F3E, 16K0F3E is the worst case and therefore only 16K0F3E will be shown.

6.7.2. Test Result (Analog)

Not Applicable.

6.7.3. Test Setup (Digital)

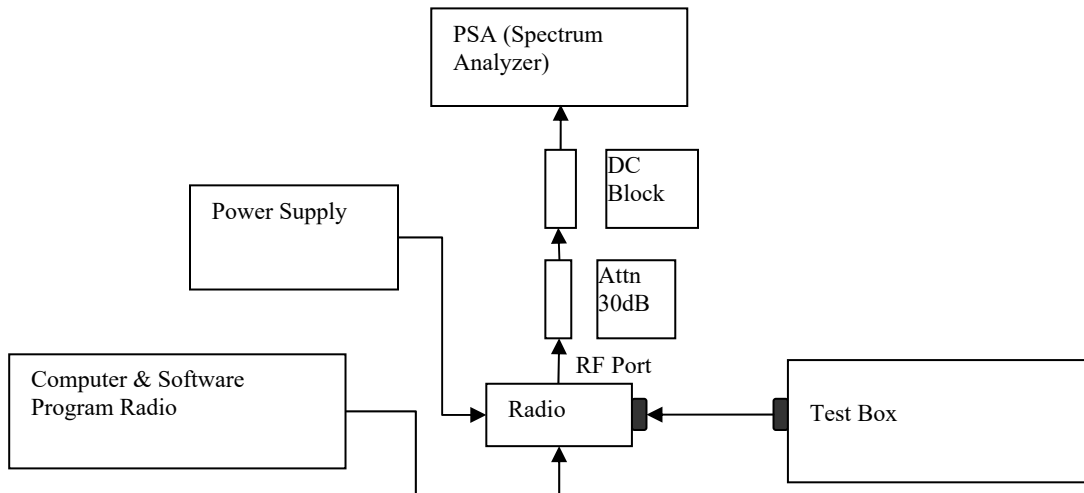

- 1) Program and set radio to operate in desire test frequency and digital mode with modulation. (*4FSK, C4FM or other digital modulation form).
- 2) Path loss for the measurement included.
- 3) Select the Occupied Bandwidth measurement for 99% and 26dB Emissions Bandwidth Measurement.
- 4) Key in the Fc and Resolution Bandwidth.
- 5) Transmit radio record the occupied Bandwidth frequencies.
- 6) Preset the spectrum analyzer for band edge measurement.
- 7) Key in the lowest and highest channels frequency, span is 60 kHz and Resolution Bandwidth is at least 1% of Emission Bandwidth.
- 8) Save the screen shot.

*Note:

- For Digital Modulation, 12.5 kHz Data F1D & FXD would be the same. Therefore only measurements with F1D modulation shown below.
- For Digital Modulation, 12.5 kHz Data F1E & FXE would be the same. Therefore only measurements with F1E modulation shown below.

6.7.4. Test Result (Digital)

Not Applicable

6.7.5. Test Limit

The power of any emission outside of the authorized operating frequency ranges must be attenuated below the transmitting power (P) by a factor of at least $43 + 10 \log(P)$ dB.

6.8. Transient Frequency Behavior

6.8.1. Test Setup

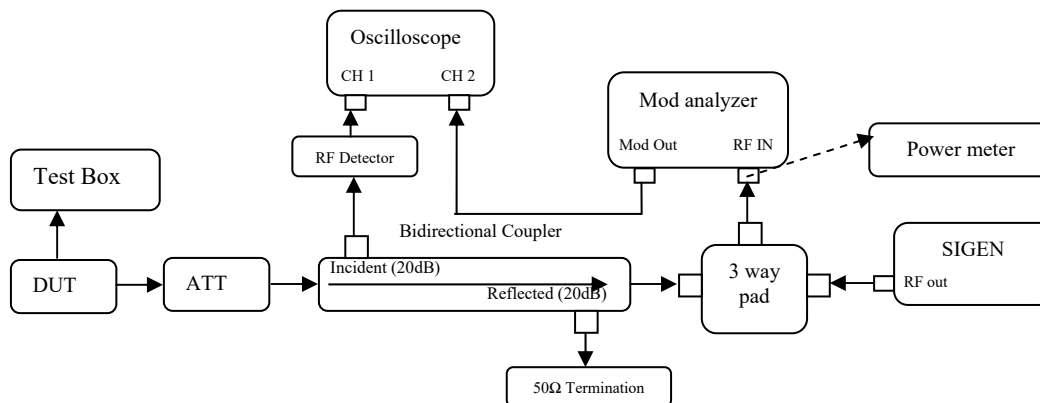

- 1) Connect the setup as figure above.
- 2) Path loss for the measurement included.
- 3) Set on Sigen with the assigned center frequency, internal 1 kHz FM tone.
FM Deviation: Analog 25kHz Channel Spacing = 25 kHz
Analog 12.5 kHz Channel Spacing = 12.5 kHz
C4FM = 12.5 kHz
- 4) Turn on 50 kHz high pass filter and 15 kHz low pass filter on modulation analyzer.
- 5) Supply sufficient attenuation ATT to provide the output power of ≤ -11 dBm into power meter when DUT is keying up.
- 6) Note the power level on power meter and dekey the DUT.
- 7) Adjust the amplitude of the signal generator to the level power meter, maintained the amplitude throughout the rest of the measurement.
- 8) Connect the output to modulation analyzer.
- 9) Reduce 30dB attenuation and transmit the radio to get the trigger line.
- 10) Capture the screen shot for key-up (rising edge) and de-key (falling edge) mode.

6.8.2. Test Result

Not Applicable.

6.8.3. Test Limit

Transmitters designed to operate in the 150-174 MHz and 421-512 MHz frequency bands must maintain transient frequencies within the maximum frequency difference limits during the time intervals indicated:

Time intervals ^{1 2}	Maximum frequency difference ³	All equipment	
		150 to 174 MHz	421 to 512 MHz
Transient Frequency Behavior for Equipment Designed to Operate on 25 kHz Channels			
t ₁ ⁴	±25.0 kHz	5.0 ms	10.0 ms
t ₂	±12.5 kHz	20.0 ms	25.0 ms
t ₃ ⁴	±25.0 kHz	5.0 ms	10.0 ms
Transient Frequency Behavior for Equipment Designed to Operate on 12.5 kHz Channels			
t ₁ ⁴	±12.5 kHz	5.0 ms	10.0 ms
t ₂	±6.25 kHz	20.0 ms	25.0 ms
t ₃ ⁴	±12.5 kHz	5.0 ms	10.0 ms
Transient Frequency Behavior for Equipment Designed to Operate on 6.25 kHz Channels			
t ₁ ⁴	±6.25 kHz	5.0 ms	10.0 ms
t ₂	±3.125 kHz	20.0 ms	25.0 ms
t ₃ ⁴	±6.25 kHz	5.0 ms	10.0 ms

¹ t_{on} is the instant when a 1 kHz test signal is completely suppressed, including any capture time due to phasing.

t₁ is the time period immediately following t_{on}.

t₂ is the time period immediately following t₁.

t₃ is the time period from the instant when the transmitter is turned off until t_{off}.

t_{off} is the instant when the 1 kHz test signal starts to rise.

² During the time from the end of t₂ to the beginning of t₃, the frequency difference must not exceed the limits specified in §90.213.

³ Difference between the actual transmitter frequency and the assigned transmitter frequency.

⁴ If the transmitter carrier output power rating is 6 watts or less, the frequency difference during this time period may exceed the maximum frequency difference for this time period.

6.9. Adjacent Channel Power

6.9.1. Test Setup (Analog)

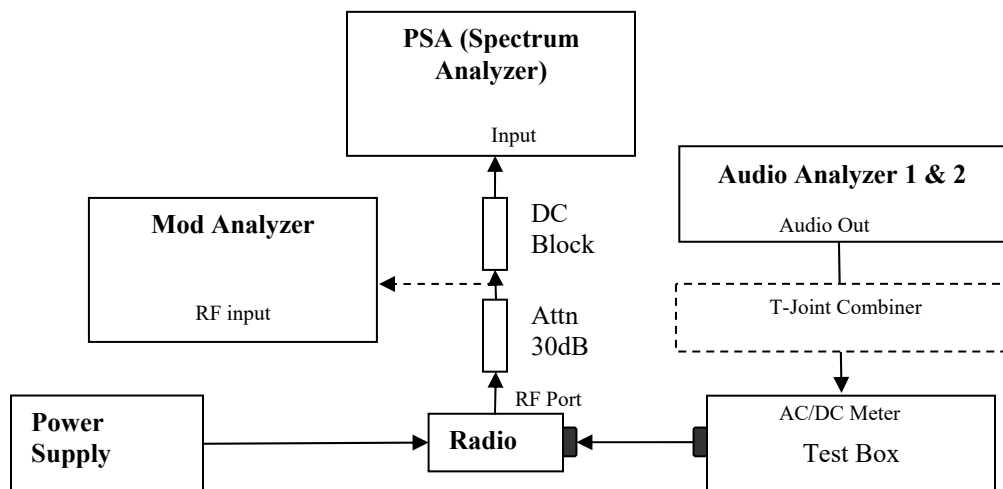

- 1) The DUT transmitter output port was connected to modulation analyzer.
- 2) Transmit the radio and turn on 1st audio analyzer with audio frequency 650Hz, 50% rated deviation, and record the amplitude value as AmpT1.
- 3) Turn off Audio analyzer 1 and turn on audio analyzer 2, set the audio frequency to 2.2 kHz and 50% deviation. Record the amplitude as AmpT2.
- 4) Turn both audio analyzers ON and up 10dB amplitude level.
- 5) Connect the output to PSA and set to assigned center frequency.
- 6) Set Span, Resolution Bandwidth and Video Bandwidth per rules part.
- 7) Transmit the radio and record the Adjacent Channel Power value in dBc.

6.9.2. Test Result

Not Applicable.

6.9.3. Test Setup (Digital)

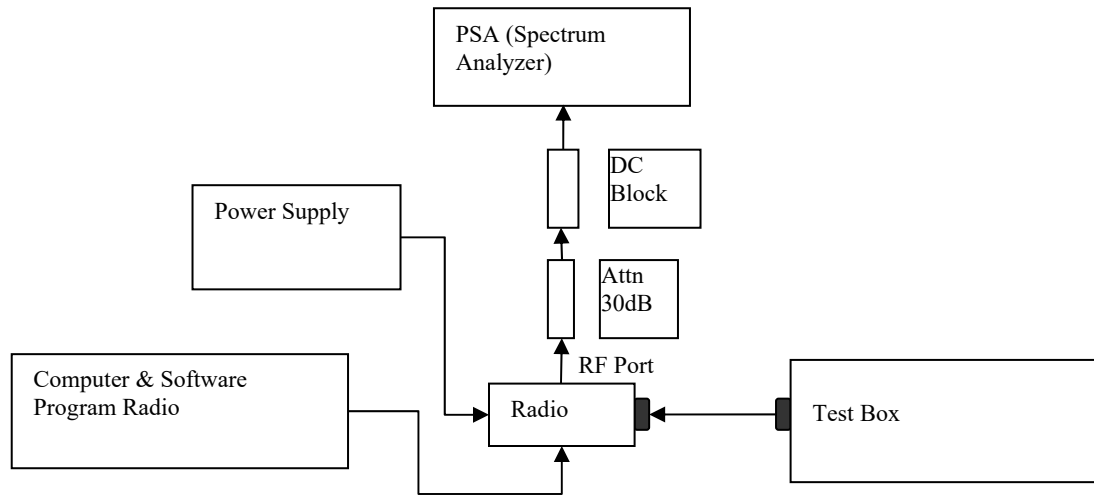

- 1) Program and set radio to operate in desire test frequency and digital mode with modulation. (4FSK, C4FM or other digital modulation form).
- 2) Prepare setup as per picture.
- 3) Turn on the ACP Measurement – Press Measure, ACP.
- 4) Set Span, Resolution Bandwidth and Video Bandwidth as per rules part.
- 5) Transmit the radio and record the Adjacent Channel Power value in dBc.

6.9.4. Test Result

Not Applicable.

6.9.5. Test Limit

12.5 kHz MOBILE TRANSMITTER ACP REQUIREMENTS

Offset from center frequency (kHz)	Measurement bandwidth (kHz)	Maximum ACP relative (dBc)
9.375	6.25	-40
15.625	6.25	-60
21.875	6.25	-60
37.50	25.00	-60
62.50	25.00	-65
87.50	25.00	-65
150.00	100	-65
250.00	100	-65
350.00	100	-65
>400 to 12 MHz	30 (s)	-75
12 MHz to paired receive band	30 (s)	-75
In the paired receive band	30 (s)	-100

25 kHz MOBILE TRANSMITTER ACP REQUIREMENTS

Offset from center frequency (kHz)	Measurement bandwidth (kHz)	Maximum ACP relative (dBc)
15.625	6.25	-40
21.875	6.25	-60
37.50	25	-60
62.50	25	-65
87.50	25	-65
150.00	100	-65
250.00	100	-65
350.00	100	-65
>400 kHz to 12 MHz	30 (s)	-75
12 MHz to paired receive band	30 (s)	-75
In the paired receive band	30 (s)	-100

12.5 kHz BASE TRANSMITTER ACP REQUIREMENTS

Offset from center frequency (kHz)	Measurement bandwidth (kHz)	Maximum ACP (dBc)
9.375	6.25	-40
15.625	6.25	-60
21.875	6.25	-60
37.5	25	-60
62.5	25	-65
87.5	25	-65
150	100	-65
250	100	-65
350.00	100	-65
>400 kHz to 12 MHz	30 (s)	-80
12 MHz to paired receive band	30 (s)	-80
In the paired receive band	30 (s)	-85

25 kHz BASE TRANSMITTER ACP REQUIREMENTS

Offset from center frequency (kHz)	Measurement bandwidth (kHz)	Maximum ACP (dBc)
15.625	6.25	-40
21.875	6.25	-60
37.5	25	-60
62.5	25	-65
87.5	25	-65
150	100	-65
250	100	-65
350	100.00	-65
>400 kHz to 12 MHz	30 (s)	-80
12 MHz to paired receive band	30 (s)	-80
In the paired receive band	30 (s)	-85

6.10. Conducted Spurious Emission

6.10.1. Test Setup

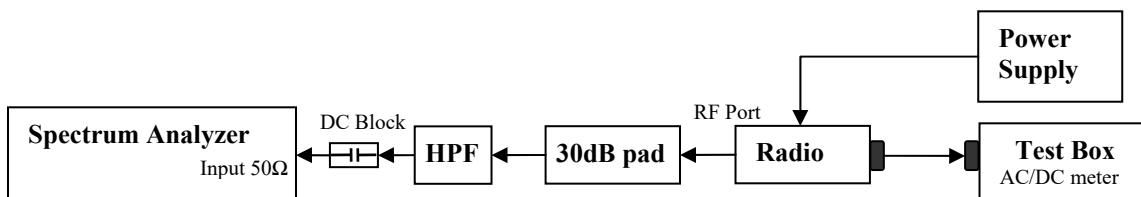

- 1) The DUT transmitter output port was connected to Spectrum Analyzer with above setup.
- 2) Program and set radio to operate in desire test frequency and mode. (Analog / digital modulation form).
- 3) Path loss for the measurement included.
- 4) Set the PSA Resolution Bandwidth as per rules part.
- 5) Set the Ref offset from the pathloss offset calibration file.
- 6) Adjust the center frequency of the spectrum analyzer for incremental coverage of the range from:
 - a. 9 KHz to $F_c - \text{Test Bandwidth}$
 - b. $F_c + \text{Test Bandwidth}$ to $2F_c - 5\text{MHz}$.
- 7) Key up the DUT, Peak Search the highest Spur and record the levels of spurious emissions
- 8) Dekey the DUT.
- 9) Turn On High Pass Filter path and Key up the DUT.
- 10) Adjust the PSA Freq for incremental coverage of range from $2F_c$ to $10F_c$
- 11) Key up the DUT and record the highest spur levels of spurious emissions.

6.10.2. Test Result (Analog)

Analog: 806.0125. MHz, 25 kHz Channel Spacing, Max. Power

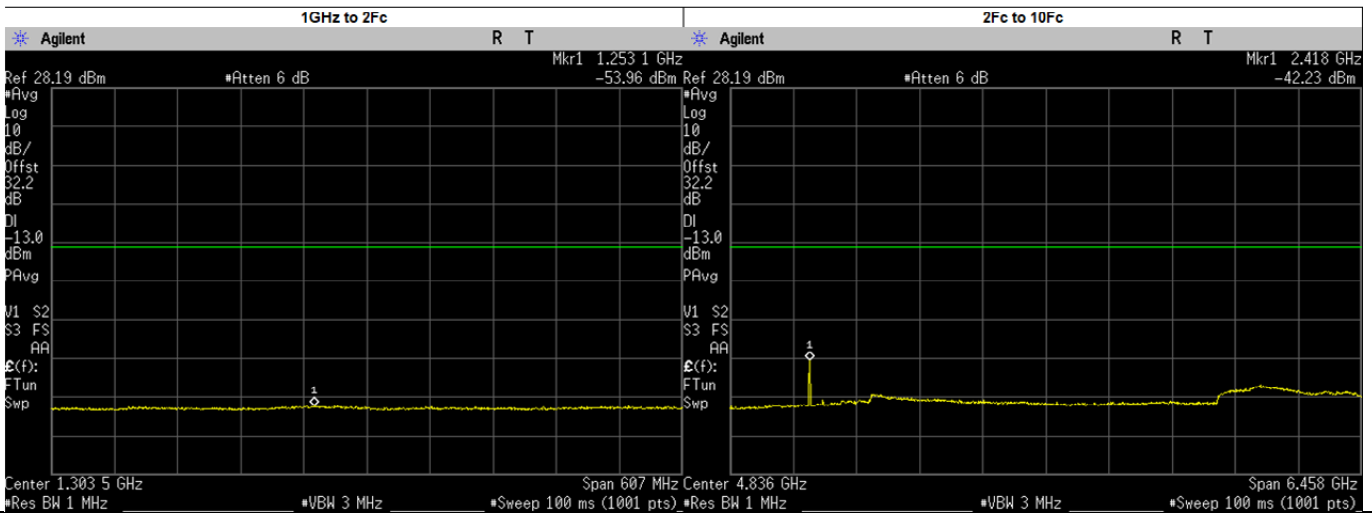
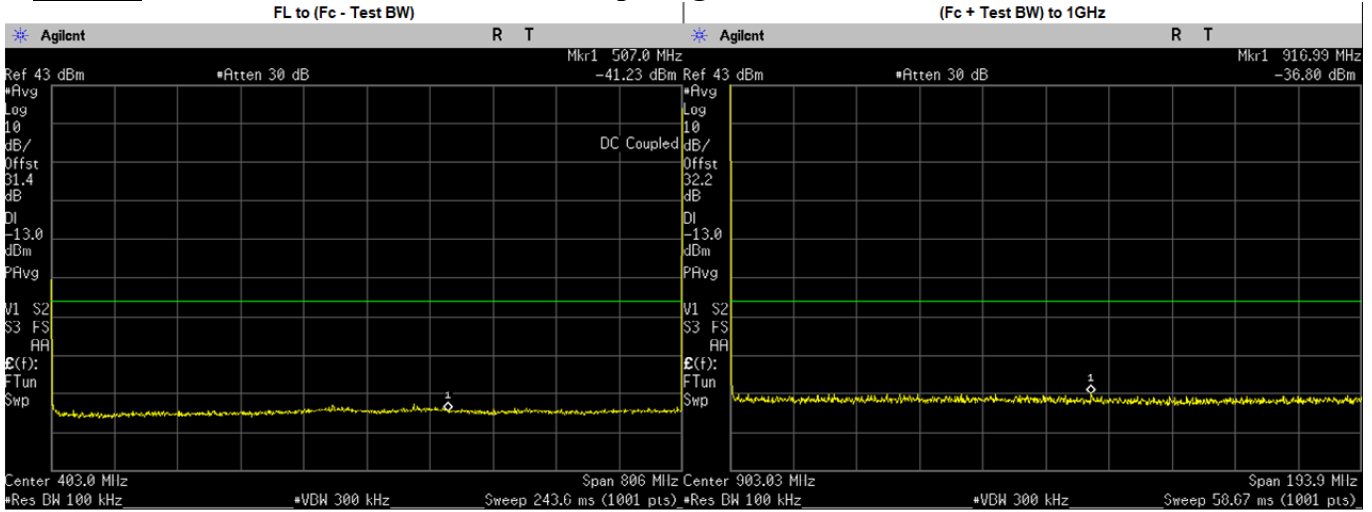

Frequency Range	Highest Spur Frequency (MHz)	Spurious Level (dBm)	Failing Limit (dBm)	Results
FL to (Fc - Test BW)	507.0000	-41.2280	-13.00	PASS
(Fc + Test BW) to 1GHz	916.9947	-36.8000	-13.00	PASS
1GHz to 2Fc	1253.1290	-53.9600	-13.00	PASS
2Fc to 10Fc	2418.0000	-42.2300	-13.00	PASS
	1612.0250	-54.3085	-13.00	PASS
	2418.0370	-45.0547	-13.00	PASS
	3224.0500	-51.9039	-13.00	PASS
	4030.0620	-53.2339	-13.00	PASS
	4836.0750	-53.2500	-13.00	PASS
	5642.0870	-53.6492	-13.00	PASS
	6448.1000	-53.4214	-13.00	PASS
	7254.1130	-49.6607	-13.00	PASS
8060.1250	-51.4294	-13.00	PASS	

Analog: 806.0125. MHz, 25. kHz Channel Spacing, Low. Power

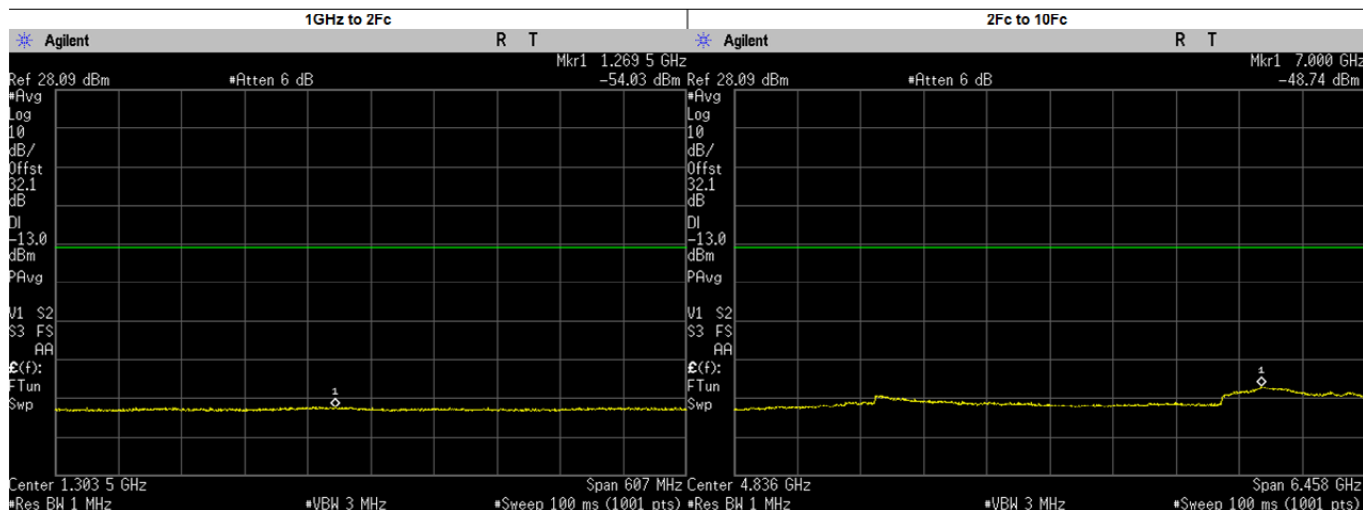
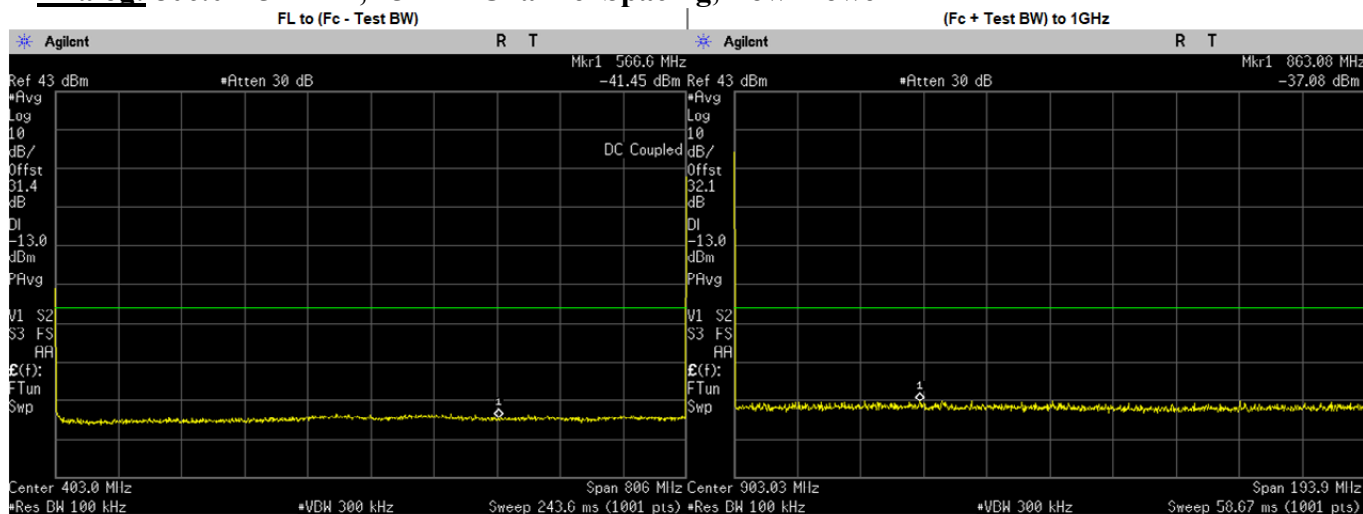

Frequency Range	Highest Spur Frequency (MHz)	Spurious Level (dBm)	Failing Limit (dBm)	Results
FL to (Fc - Test BW)	566.6000	-41.4500	-13.00	PASS
(Fc + Test BW) to 1GHz	863.0801	-37.0800	-13.00	PASS
1GHz to 2Fc	1269.5190	-54.0300	-13.00	PASS
2Fc to 10Fc	6999.5380	-48.7400	-13.00	PASS
	1612.0250	-54.8392	-13.00	PASS
	2418.0370	-53.9469	-13.00	PASS
	3224.0500	-51.8517	-13.00	PASS
	4030.0620	-53.2549	-13.00	PASS
	4836.0750	-53.4950	-13.00	PASS
	5642.0870	-53.4519	-13.00	PASS
	6448.1000	-53.4844	-13.00	PASS
	7254.1130	-49.6075	-13.00	PASS
8060.1250	-51.6306	-13.00	PASS	

Analog: 814.9875. MHz, 25. kHz Channel Spacing, Max. Power

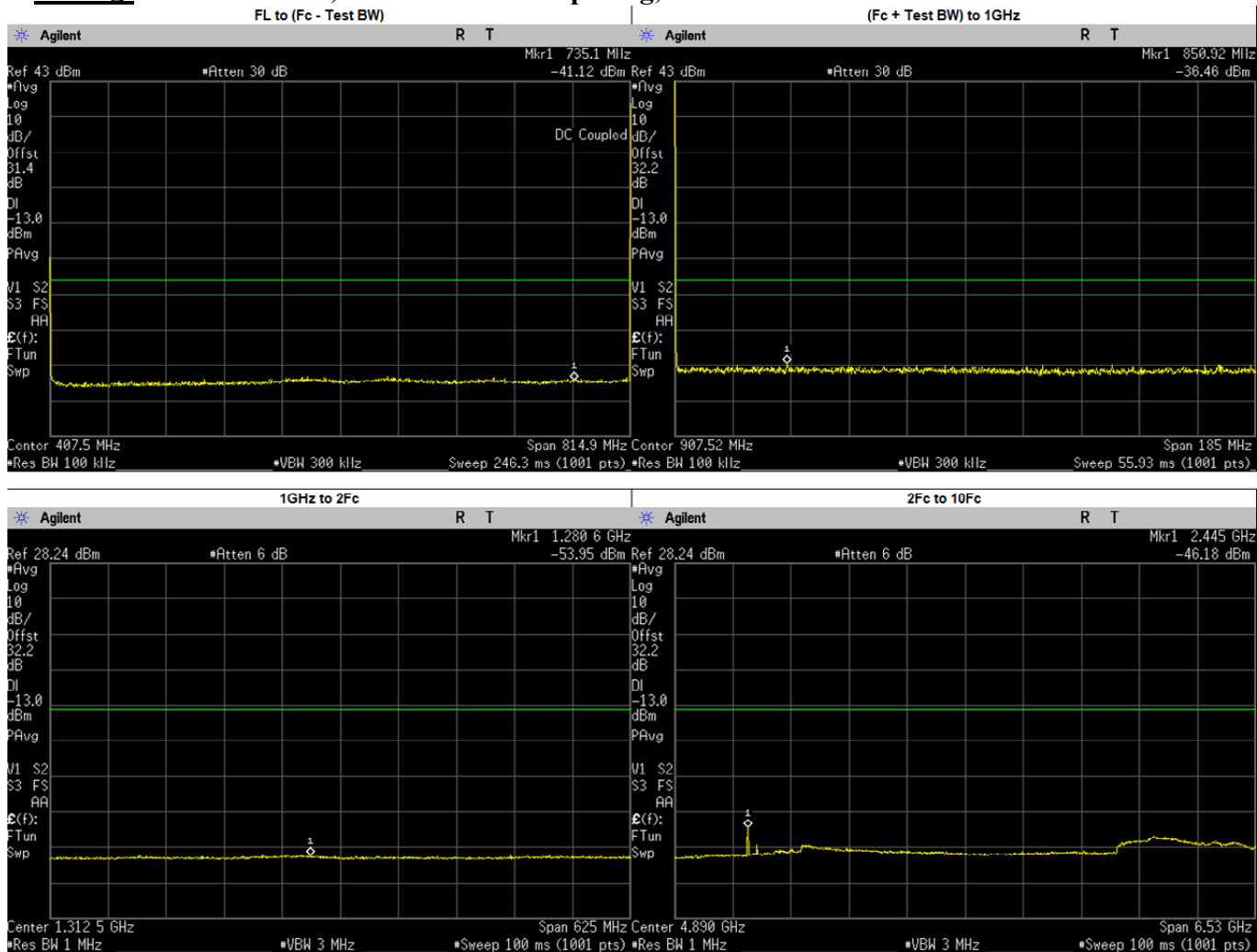

Frequency Range	Highest Spur Frequency (MHz)	Spurious Level (dBm)	Failing Limit (dBm)	Results
FL to (Fc - Test BW)	735.1000	-41.1170	-13.00	PASS
(Fc + Test BW) to 1GHz	850.9202	-36.4600	-13.00	PASS
1GHz to 2Fc	1280.6140	-53.9500	-13.00	PASS
2Fc to 10Fc	2445.0000	-46.1800	-13.00	PASS
	1629.9750	-54.5322	-13.00	PASS
	2444.9630	-48.2904	-13.00	PASS
	3259.9500	-52.0685	-13.00	PASS
	4074.9370	-53.0583	-13.00	PASS
	4889.9250	-53.5910	-13.00	PASS
	5704.9130	-53.3015	-13.00	PASS
	6519.9000	-53.2612	-13.00	PASS
7334.8870	-50.1473	-13.00	PASS	
8149.8750	-51.7247	-13.00	PASS	

Analog: 814.9875. MHz, 25. kHz Channel Spacing, Low. Power

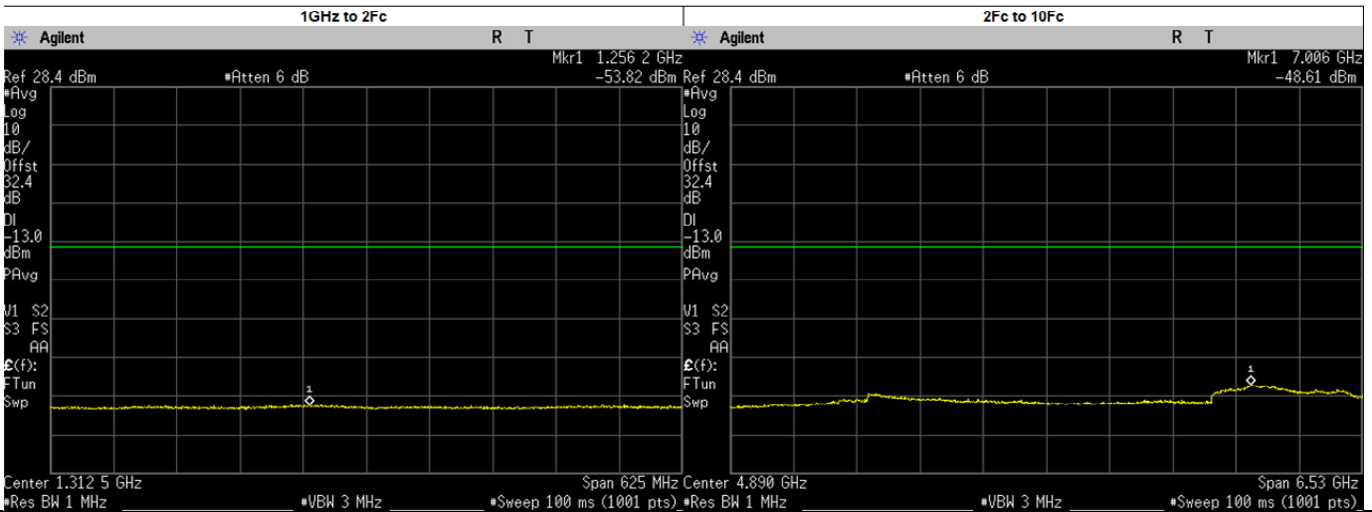
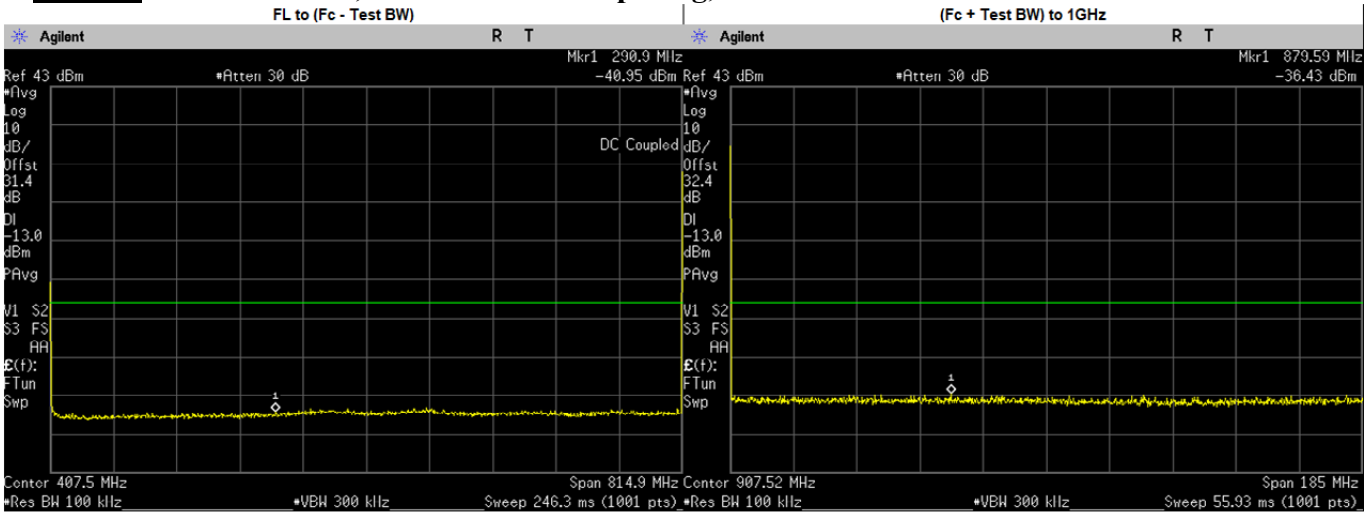

Frequency Range	Highest Spur Frequency (MHz)	Spurious Level (dBm)	Failing Limit (dBm)	Results
FL to (Fc - Test BW)	290.9000	-40.9480	-13.00	PASS
(Fc + Test BW) to 1GHz	879.5894	-36.4300	-13.00	PASS
1GHz to 2Fc	1256.2400	-53.8200	-13.00	PASS
2Fc to 10Fc	7005.6130	-48.6100	-13.00	PASS
	1629.9750	-54.5997	-13.00	PASS
	2444.9630	-53.9278	-13.00	PASS
	3259.9500	-51.8285	-13.00	PASS
	4074.9370	-52.8623	-13.00	PASS
	4889.9250	-53.6980	-13.00	PASS
	5704.9130	-53.3211	-13.00	PASS
	6519.9000	-53.1370	-13.00	PASS
	7334.8870	-49.6795	-13.00	PASS
8149.8750	-51.8860	-13.00	PASS	

Analog: 823.9875. MHz, 25. kHz Channel Spacing, Max. Power

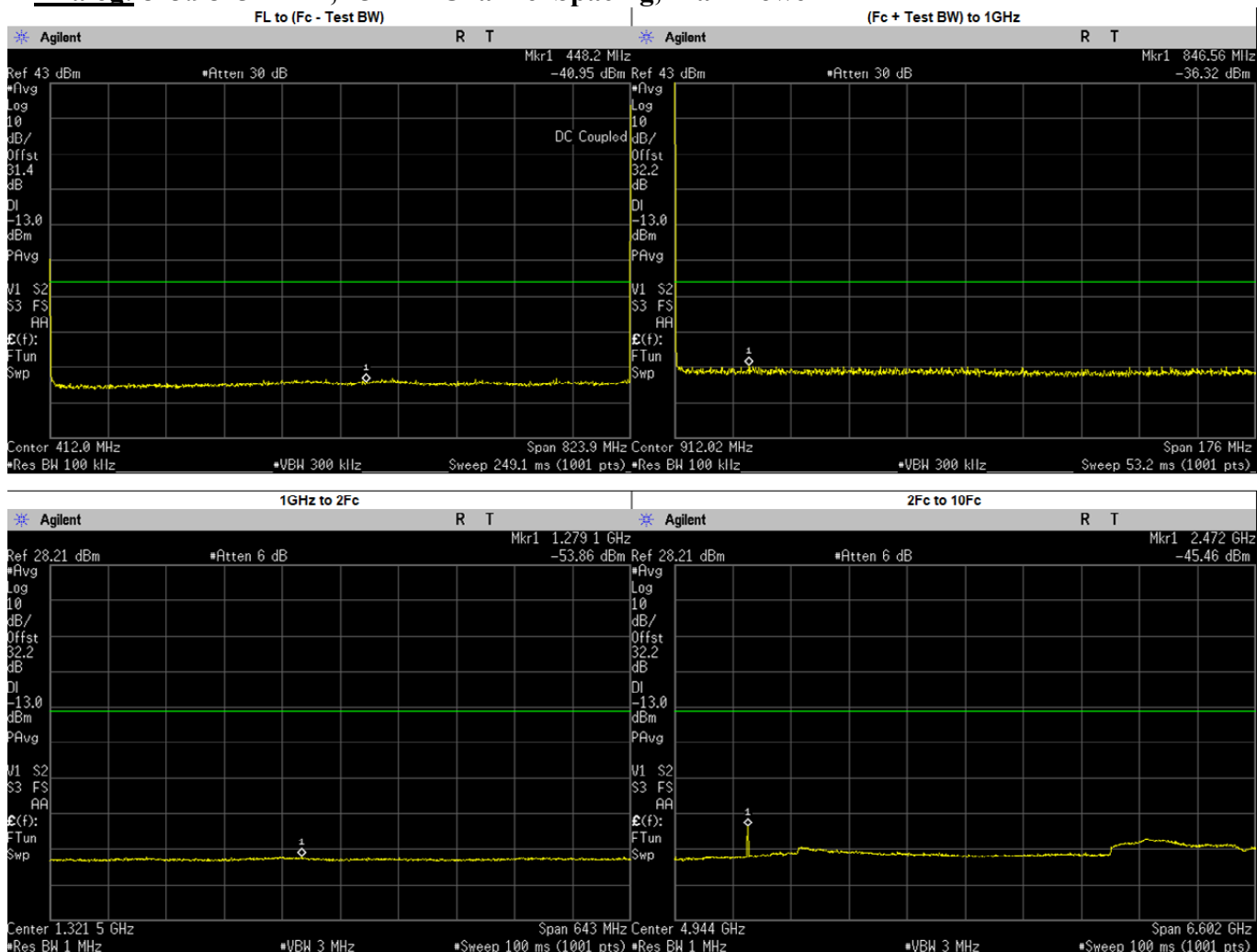

Frequency Range	Highest Spur Frequency (MHz)	Spurious Level (dBm)	Failing Limit (dBm)	Results
FL to (Fc - Test BW)	448.2000	-40.9510	-13.00	PASS
(Fc + Test BW) to 1GHz	846.5607	-36.3200	-13.00	PASS
1GHz to 2Fc	1279.0510	-53.8600	-13.00	PASS
2Fc to 10Fc	2472.0000	-45.4600	-13.00	PASS
	1647.9750	-53.9787	-13.00	PASS
	2471.9630	-47.6055	-13.00	PASS
	3295.9500	-51.8686	-13.00	PASS
	4119.9370	-53.1988	-13.00	PASS
	4943.9250	-53.6940	-13.00	PASS
	5767.9130	-53.1635	-13.00	PASS
	6591.9000	-53.1521	-13.00	PASS
7415.8870	-50.4858	-13.00	PASS	
8239.8750	-51.3141	-13.00	PASS	

Analog: 823.9875. MHz, 25. kHz Channel Spacing, Low. Power

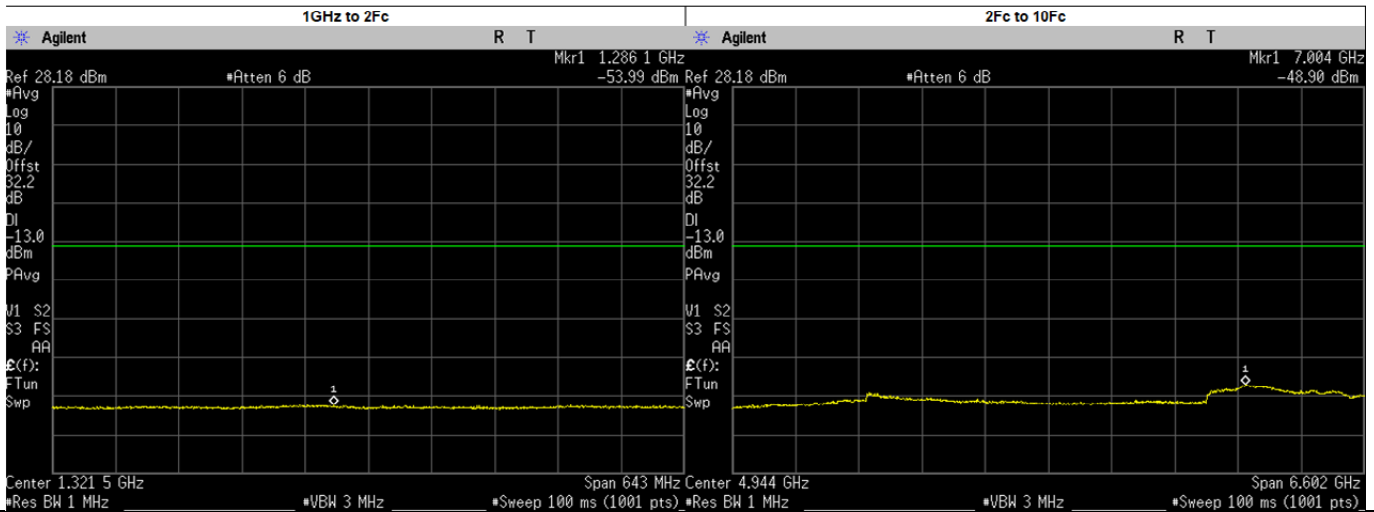
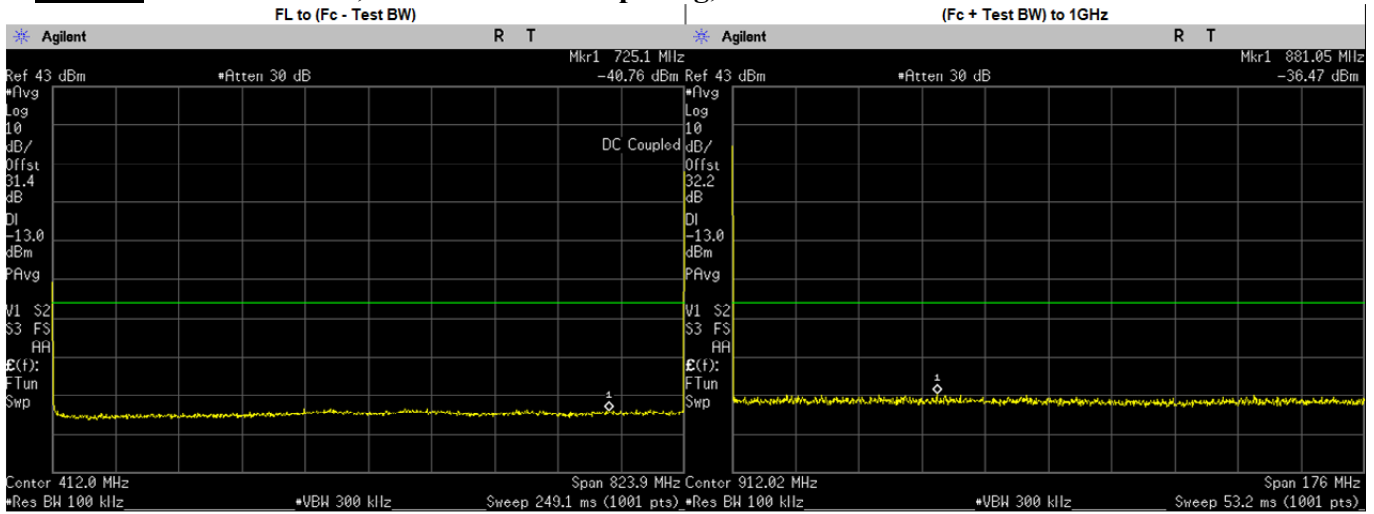

Frequency Range	Highest Spur Frequency (MHz)	Spurious Level (dBm)	Failing Limit (dBm)	Results
FL to (Fc - Test BW)	725.1000	-40.7570	-13.00	PASS
(Fc + Test BW) to 1GHz	881.0494	-36.4700	-13.00	PASS
1GHz to 2Fc	1286.1240	-53.9900	-13.00	PASS
2Fc to 10Fc	7003.7180	-48.9000	-13.00	PASS
	1647.9750	-54.8520	-13.00	PASS
	2471.9630	-53.9193	-13.00	PASS
	3295.9500	-51.9619	-13.00	PASS
	4119.9370	-52.9245	-13.00	PASS
	4943.9250	-53.8050	-13.00	PASS
	5767.9130	-53.6653	-13.00	PASS
	6591.9000	-53.3715	-13.00	PASS
7415.8870	-50.6013	-13.00	PASS	
8239.8750	-51.6703	-13.00	PASS	

Analog: 851.0125. MHz, 25. kHz Channel Spacing, Max. Power

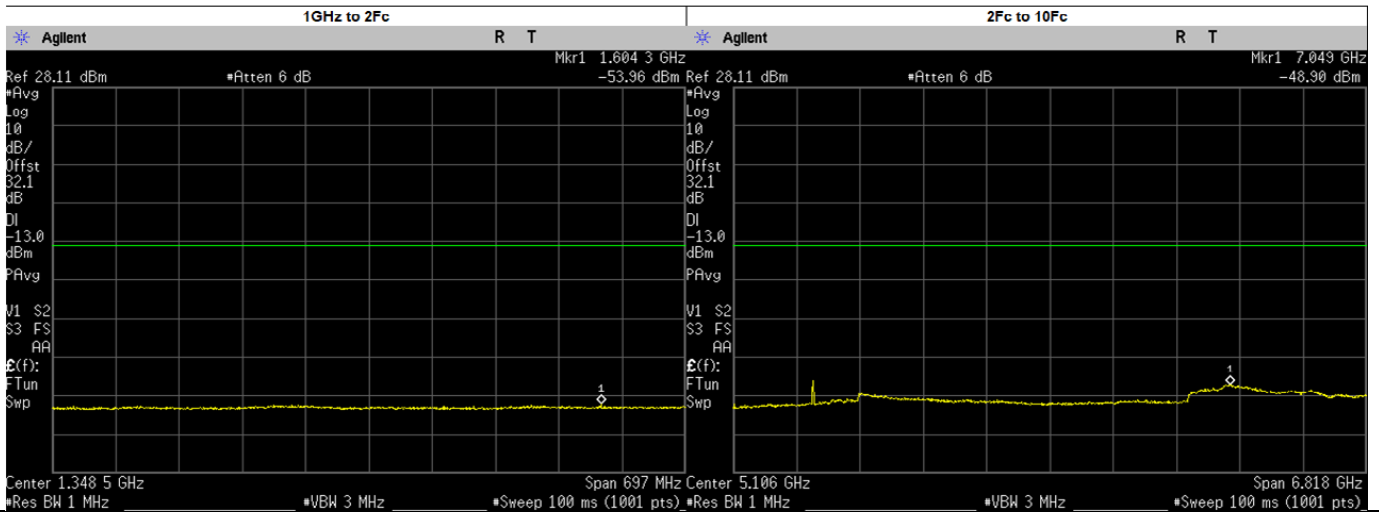
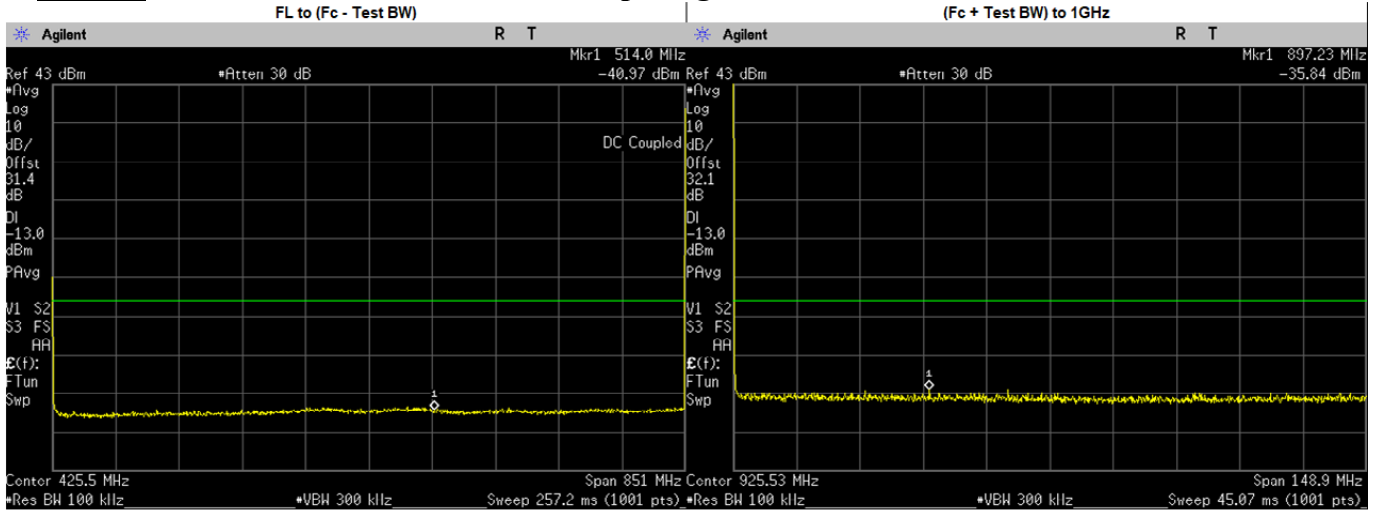

Frequency Range	Highest Spur Frequency (MHz)	Spurious Level (dBm)	Failing Limit (dBm)	Results
FL to (Fc - Test BW)	514.0000	-40.9710	-13.00	PASS
(Fc + Test BW) to 1GHz	897.2331	-35.8400	-13.00	PASS
1GHz to 2Fc	1604.3210	-53.9600	-13.00	PASS
2Fc to 10Fc	7049.2340	-48.9000	-13.00	PASS
	1702.0250	-54.1448	-13.00	PASS
	2553.0370	-49.2574	-13.00	PASS
	3404.0500	-52.3315	-13.00	PASS
	4255.0620	-52.9666	-13.00	PASS
	5106.0750	-53.6870	-13.00	PASS
	5957.0870	-53.2075	-13.00	PASS
	6808.1000	-50.1037	-13.00	PASS
	7659.1130	-50.8426	-13.00	PASS
	8510.1250	-51.7198	-13.00	PASS

Analog: 851.0125. MHz, 25. kHz Channel Spacing, Low. Power

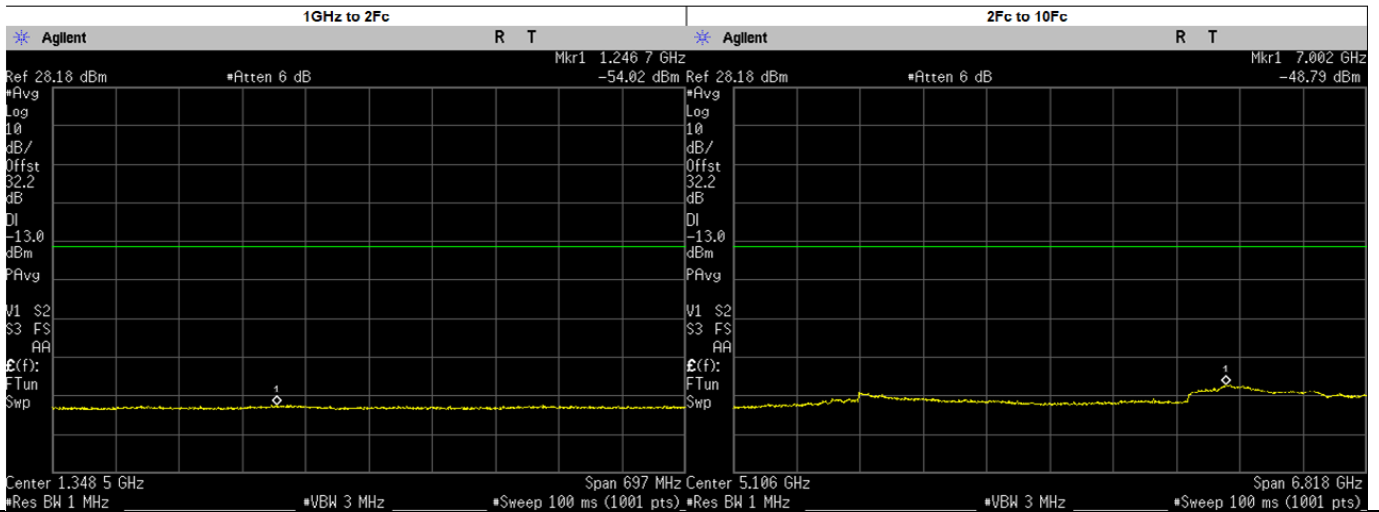
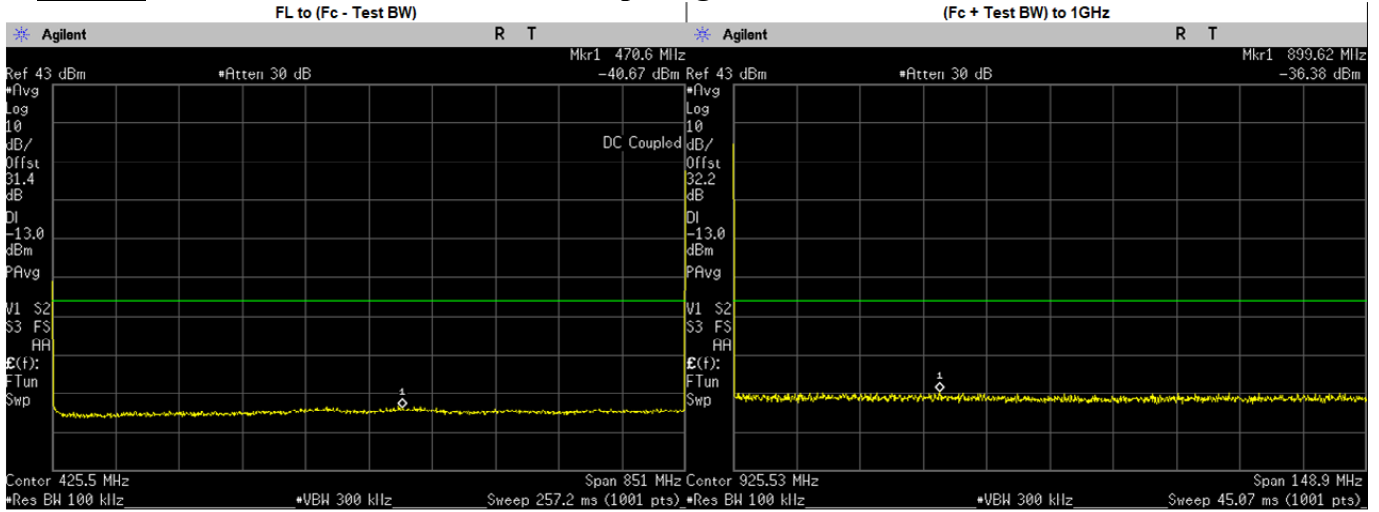

Frequency Range	Highest Spur Frequency (MHz)	Spurious Level (dBm)	Failing Limit (dBm)	Results
FL to (Fc - Test BW)	470.6000	-40.6750	-13.00	PASS
(Fc + Test BW) to 1GHz	899.6161	-36.3800	-13.00	PASS
1GHz to 2Fc	1246.7470	-54.0200	-13.00	PASS
2Fc to 10Fc	7001.5070	-48.7900	-13.00	PASS
	1702.0250	-54.5487	-13.00	PASS
	2553.0370	-53.9649	-13.00	PASS
	3404.0500	-52.3401	-13.00	PASS
	4255.0620	-52.8727	-13.00	PASS
	5106.0750	-53.5110	-13.00	PASS
	5957.0870	-53.2174	-13.00	PASS
	6808.1000	-50.1353	-13.00	PASS
	7659.1130	-50.7306	-13.00	PASS
8510.1250	-51.6529	-13.00	PASS	

Analog: 860.0125. MHz, 25. kHz Channel Spacing, Max. Power

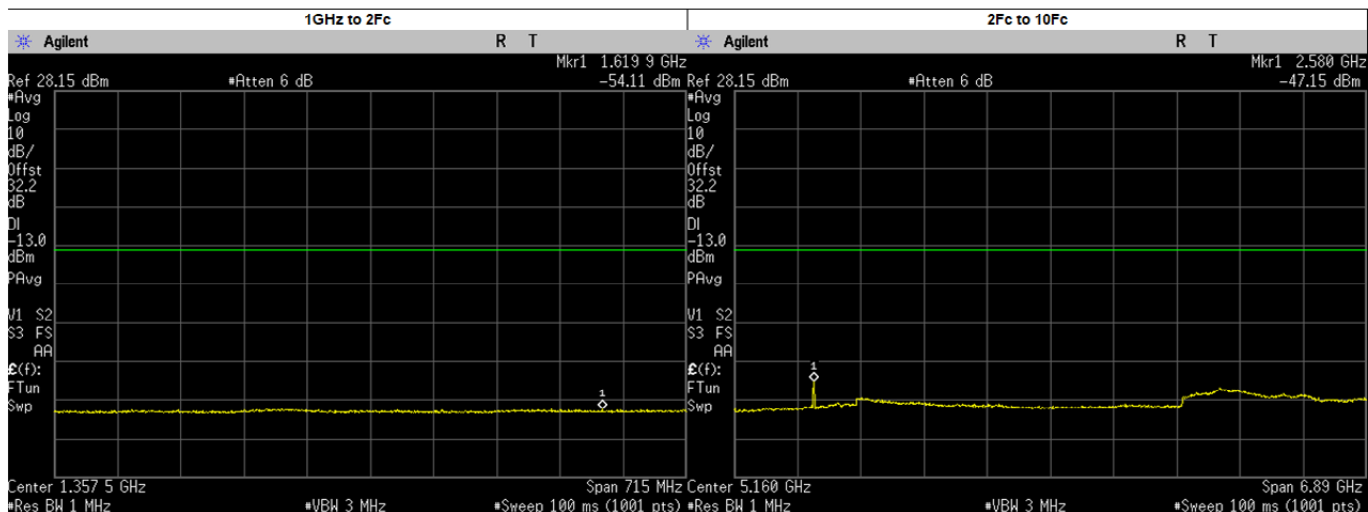
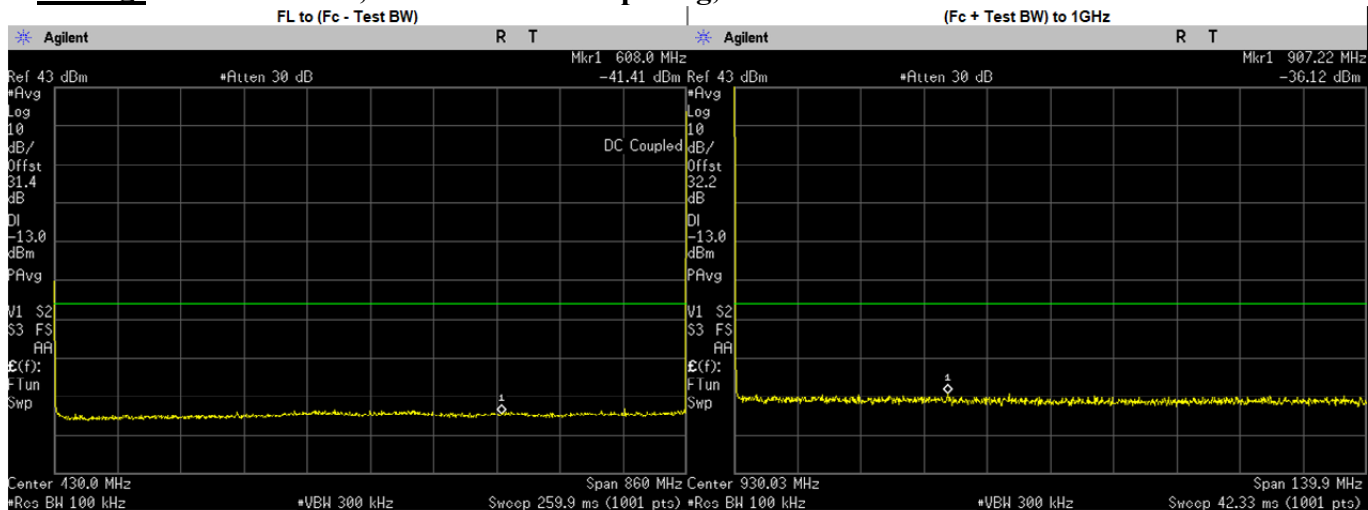

Frequency Range	Highest Spur Frequency (MHz)	Spurious Level (dBm)	Failing Limit (dBm)	Results
FL to (Fc - Test BW)	608.0000	-41.4100	-13.00	PASS
(Fc + Test BW) to 1GHz	907.2214	-36.1200	-13.00	PASS
1GHz to 2Fc	1619.9270	-54.1100	-13.00	PASS
2Fc to 10Fc	2580.0000	-47.1500	-13.00	PASS
	1720.0250	-54.0049	-13.00	PASS
	2580.0370	-48.4144	-13.00	PASS
	3440.0500	-52.3396	-13.00	PASS
	4300.0620	-53.3157	-13.00	PASS
	5160.0750	-53.7860	-13.00	PASS
	6020.0870	-53.1672	-13.00	PASS
	6880.1000	-50.4346	-13.00	PASS
7740.1130	-50.7706	-13.00	PASS	
8600.1250	-51.5793	-13.00	PASS	

Analog: 860.0125. MHz, 25. kHz Channel Spacing, Low. Power

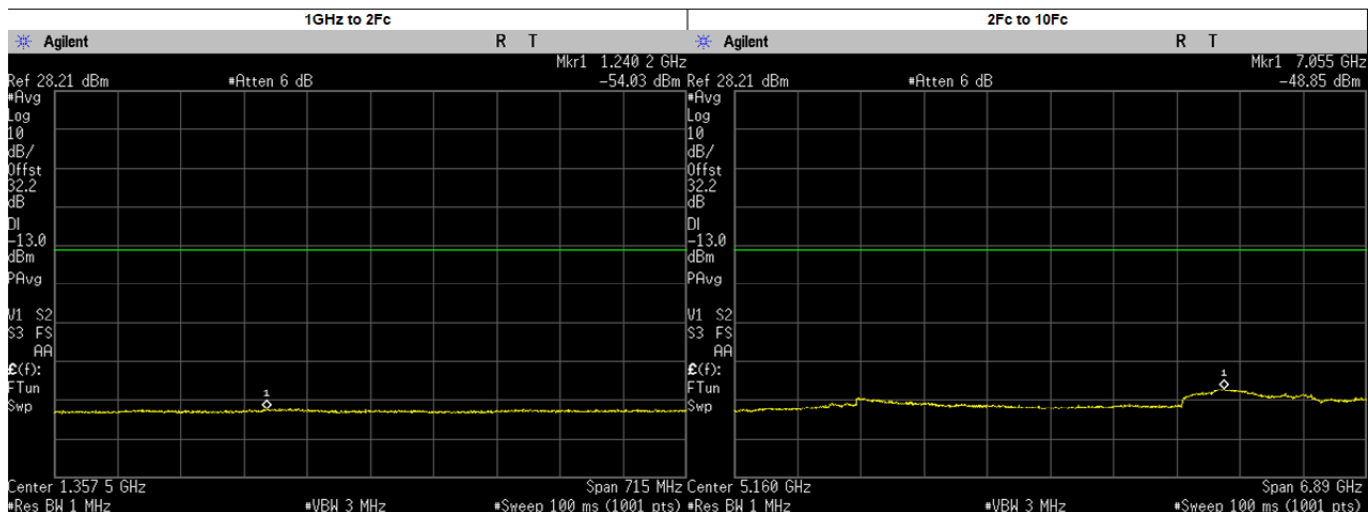
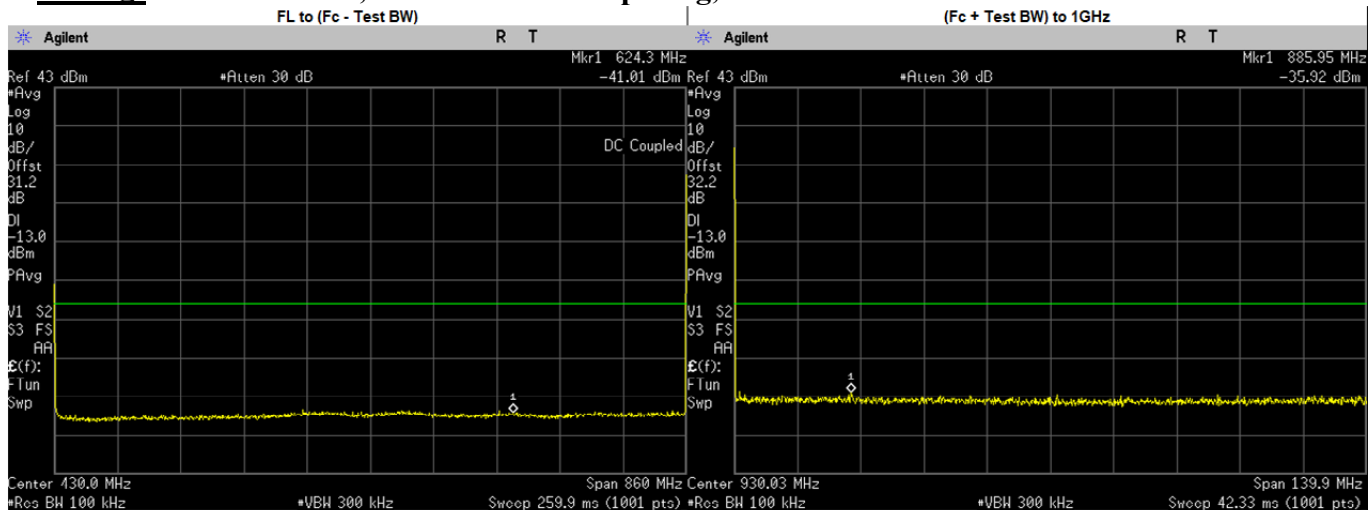

Frequency Range	Highest Spur Frequency (MHz)	Spurious Level (dBm)	Failing Limit (dBm)	Results
FL to (Fc - Test BW)	624.3000	-41.0110	-13.00	PASS
(Fc + Test BW) to 1GHz	885.9509	-35.9200	-13.00	PASS
1GHz to 2Fc	1240.2480	-54.0300	-13.00	PASS
2Fc to 10Fc	7054.8520	-48.8500	-13.00	PASS
	1720.0250	-54.8210	-13.00	PASS
	2580.0370	-53.8213	-13.00	PASS
	3440.0500	-52.3973	-13.00	PASS
	4300.0620	-53.2770	-13.00	PASS
	5160.0750	-53.7450	-13.00	PASS
	6020.0870	-52.9092	-13.00	PASS
	6880.1000	-50.1832	-13.00	PASS
	7740.1130	-50.7402	-13.00	PASS
	8600.1250	-51.5606	-13.00	PASS

Analog: 868.8875. MHz, 25. kHz Channel Spacing, Max. Power

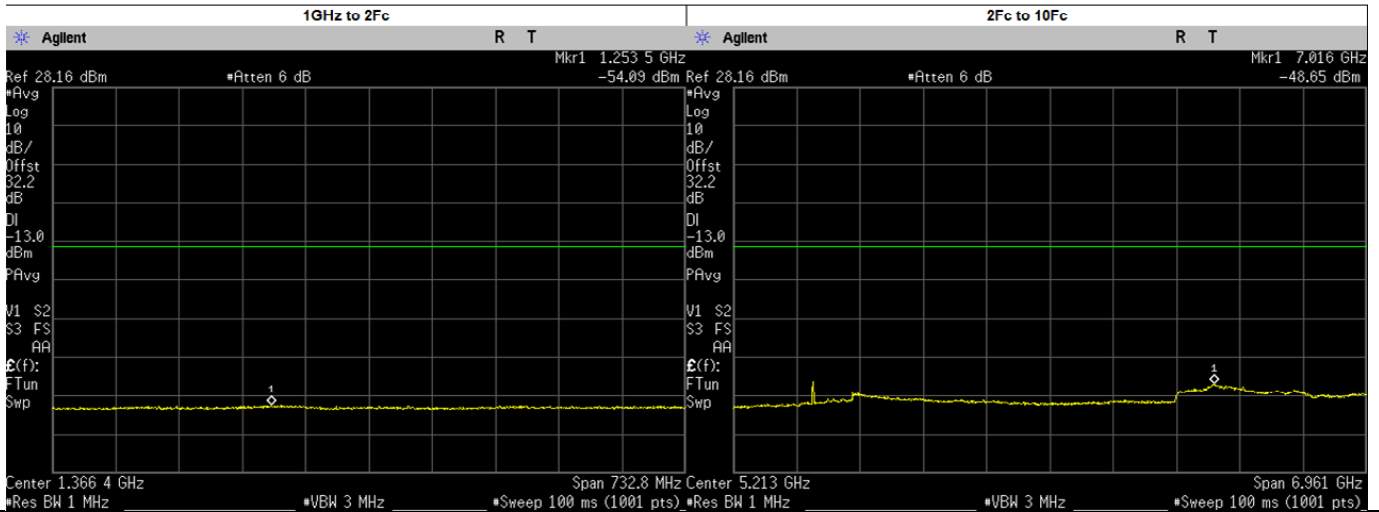
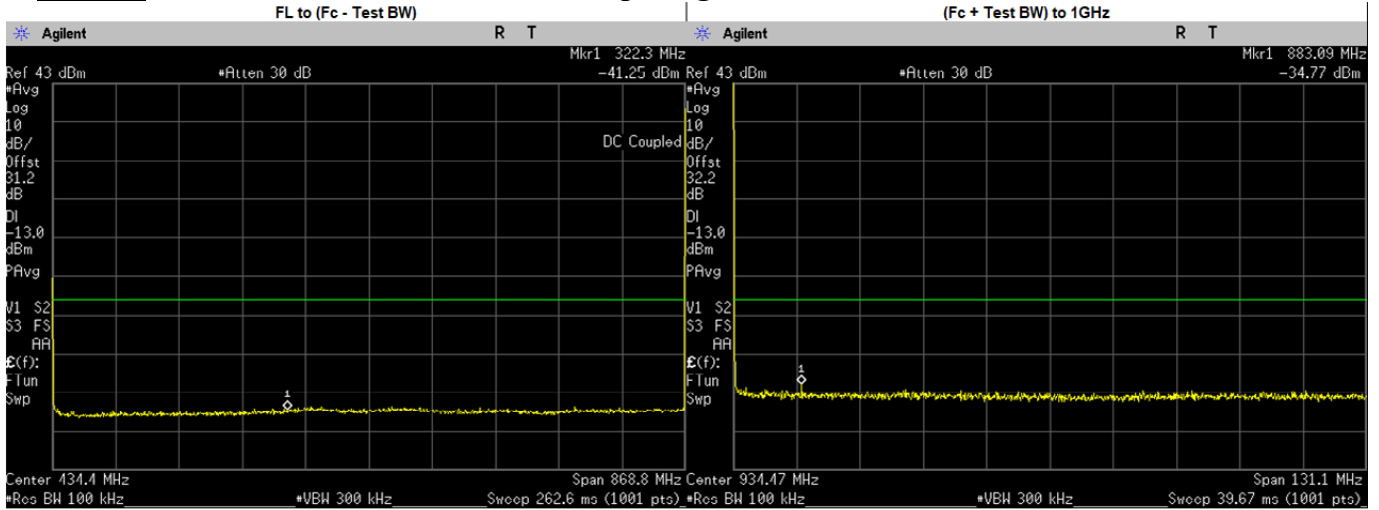

Frequency Range	Highest Spur Frequency (MHz)	Spurious Level (dBm)	Failing Limit (dBm)	Results
FL to (Fc - Test BW)	322.3000	-41.2500	-13.00	PASS
(Fc + Test BW) to 1GHz	883.0923	-34.7700	-13.00	PASS
1GHz to 2Fc	1253.5400	-54.0900	-13.00	PASS
2Fc to 10Fc	7016.2500	-48.6500	-13.00	PASS
	1737.7750	-54.5319	-13.00	PASS
	2606.6620	-49.1159	-13.00	PASS
	3475.5500	-52.5647	-13.00	PASS
	4344.4370	-53.1323	-13.00	PASS
	5213.3250	-53.7140	-13.00	PASS
	6082.2120	-53.1112	-13.00	PASS
	6951.1000	-49.5348	-13.00	PASS
	7819.9880	-51.3111	-13.00	PASS
8688.8750	-51.4159	-13.00	PASS	

Analog: 868.8875. MHz, 25. kHz Channel Spacing, Low. Power

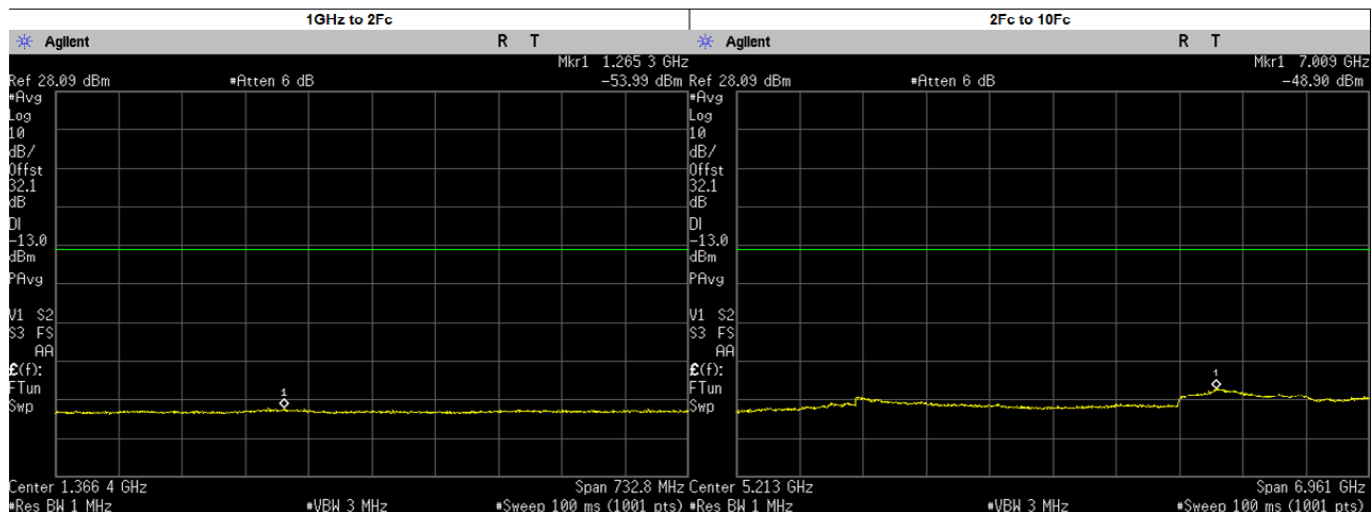
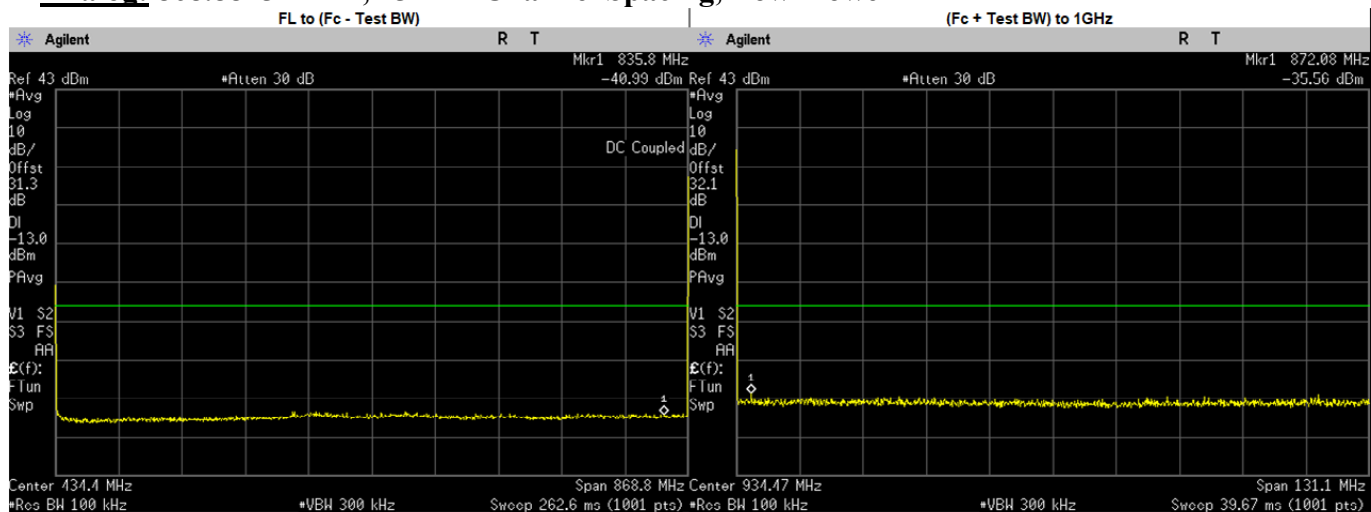

Frequency Range	Highest Spur Frequency (MHz)	Spurious Level (dBm)	Failing Limit (dBm)	Results
FL to (Fc - Test BW)	835.8000	-40.9940	-13.00	PASS
(Fc + Test BW) to 1GHz	872.0830	-35.5600	-13.00	PASS
1GHz to 2Fc	1265.2650	-53.9900	-13.00	PASS
2Fc to 10Fc	7009.2890	-48.9000	-13.00	PASS
	1737.7750	-54.8241	-13.00	PASS
	2606.6620	-54.0781	-13.00	PASS
	3475.5500	-52.6224	-13.00	PASS
	4344.4370	-53.3954	-13.00	PASS
	5213.3250	-53.9610	-13.00	PASS
	6082.2120	-53.3356	-13.00	PASS
	6951.1000	-49.9328	-13.00	PASS
	7819.9880	-51.3560	-13.00	PASS
	8688.8750	-51.5881	-13.00	PASS

6.10.3. Test Result (Digital)

Digital: 806.0125. MHz, 12.5 kHz Channel Spacing, Max. Power

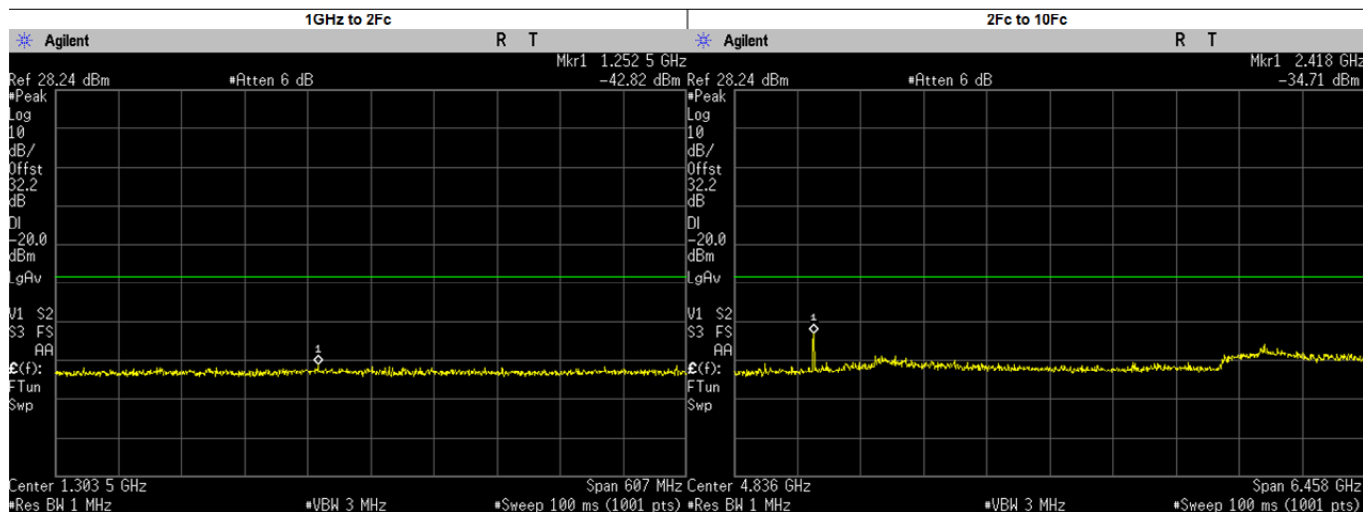
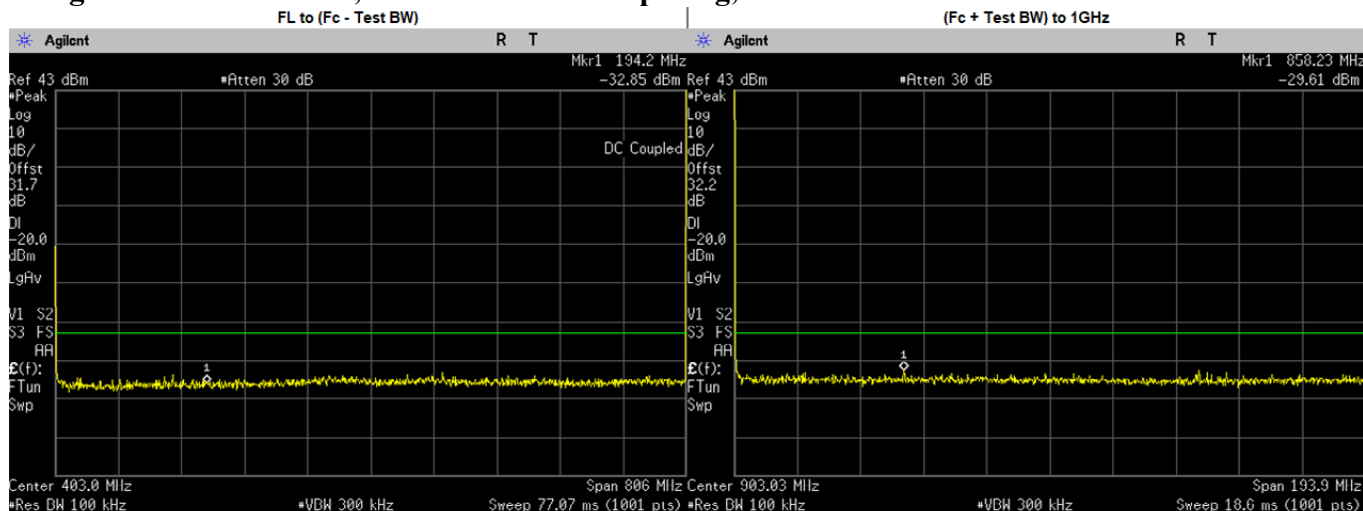

Frequency Range	Highest Spur Frequency (MHz)	Spurious Level (dBm)	Failing Limit (dBm)	Results
FL to (Fc - Test BW)	194.2000	-32.8530	-20.00	PASS
(Fc + Test BW) to 1GHz	858.2317	-29.6100	-20.00	PASS
1GHz to 2Fc	1252.5220	-42.8200	-20.00	PASS
2Fc to 10Fc	2418.0000	-34.7100	-20.00	PASS
	3224.0500	-42.1474	-20.00	PASS
	4030.0620	-43.4120	-20.00	PASS
	4836.0750	-43.4770	-20.00	PASS
	5642.0870	-44.1769	-20.00	PASS
	6448.1000	-43.7816	-20.00	PASS
	8060.1250	-42.3273	-20.00	PASS
	7031.8290	-37.5900	-20.00	PASS
	2418.0370	-35.9309	-20.00	PASS
	7254.1130	-39.9552	-20.00	PASS

Digital: 806.0125. MHz, 12.5 kHz Channel Spacing, Low. Power

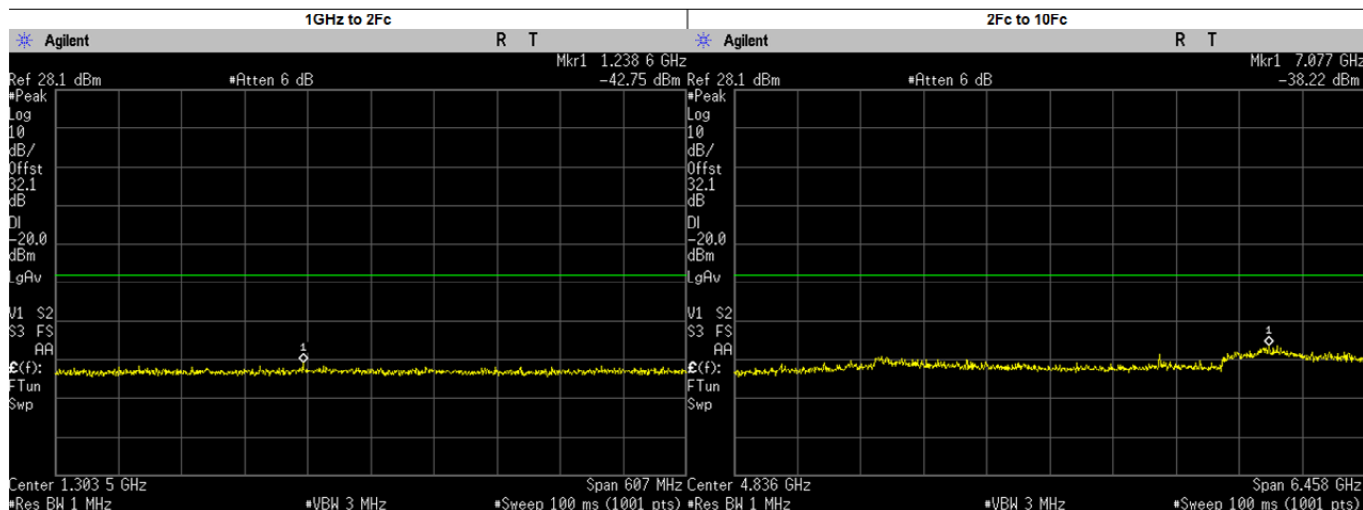
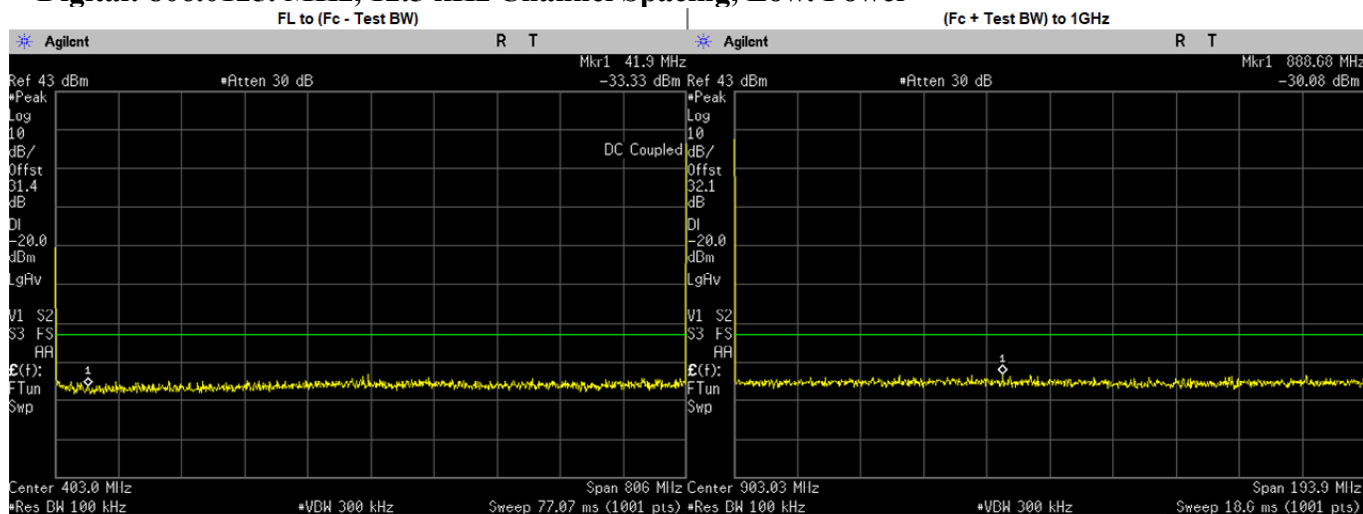

Frequency Range	Highest Spur Frequency (MHz)	Spurious Level (dBm)	Failing Limit (dBm)	Results
FL to (Fc - Test BW)	41.9000	-33.3290	-20.00	PASS
(Fc + Test BW) to 1GHz	888.6799	-30.0800	-20.00	PASS
1GHz to 2Fc	1238.5610	-42.7500	-20.00	PASS
2Fc to 10Fc	7077.0000	-38.2200	-20.00	PASS
	2418.0370	-44.6055	-20.00	PASS
	3224.0500	-43.0667	-20.00	PASS
	4030.0620	-43.5326	-20.00	PASS
	4836.0750	-44.2570	-20.00	PASS
	5642.0870	-44.1387	-20.00	PASS
	6448.1000	-44.3810	-20.00	PASS
	7254.1130	-40.1664	-20.00	PASS
	8060.1250	-41.9347	-20.00	PASS
	7077.0360	-38.2300	-20.00	PASS

Digital: 814.9875. MHz, 12.5 kHz Channel Spacing, Max. Power

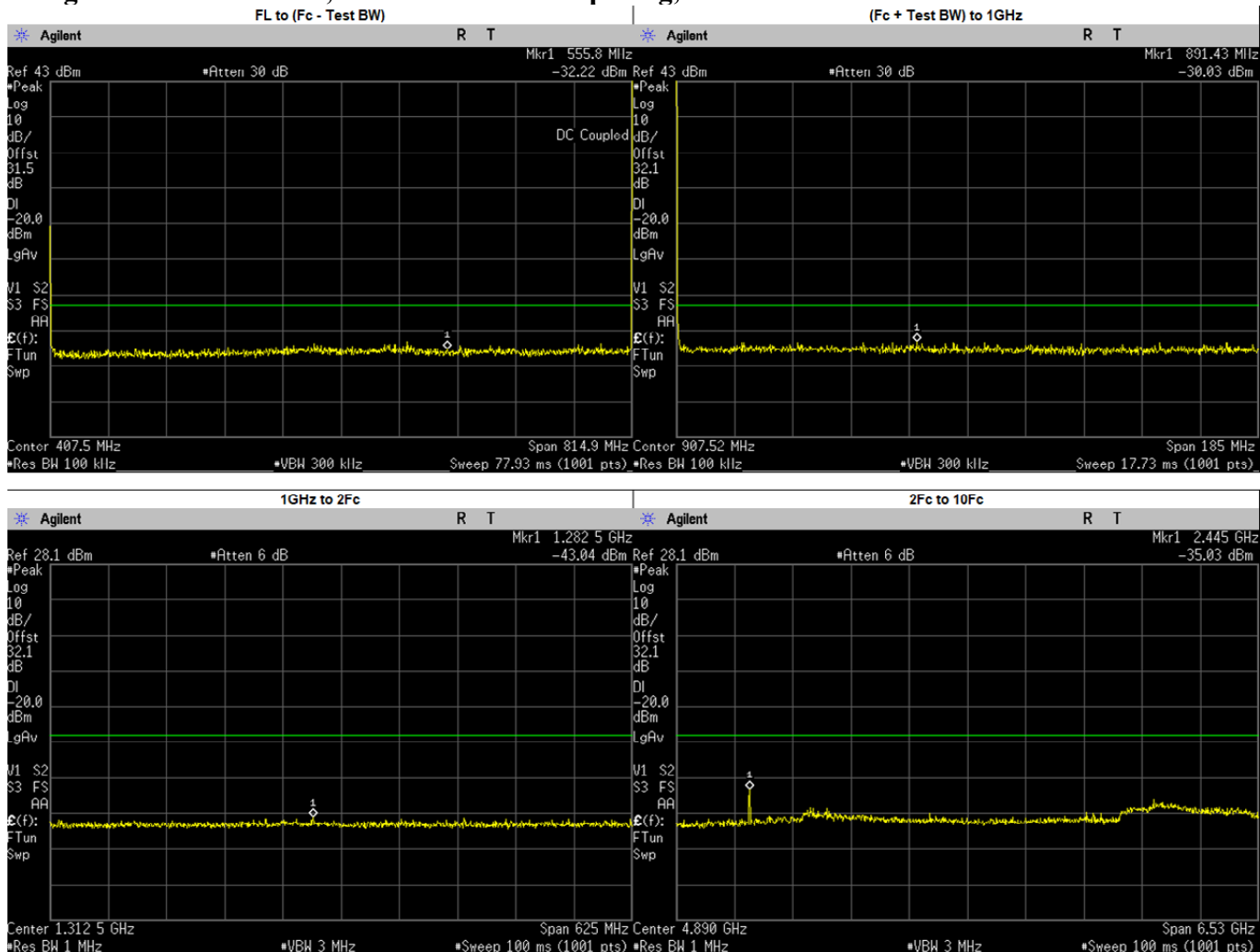

Frequency Range	Highest Spur Frequency (MHz)	Spurious Level (dBm)	Failing Limit (dBm)	Results
FL to (Fc - Test BW)	555.8000	-32.2190	-20.00	PASS
(Fc + Test BW) to 1GHz	891.4270	-30.0300	-20.00	PASS
1GHz to 2Fc	1282.4890	-43.0400	-20.00	PASS
2Fc to 10Fc	2445.0000	-35.0300	-20.00	PASS
	3259.9500	-42.5958	-20.00	PASS
	4074.9370	-43.0924	-20.00	PASS
	4889.9250	-43.1650	-20.00	PASS
	5704.9130	-43.4172	-20.00	PASS
	6519.9000	-43.3497	-20.00	PASS
	7334.8870	-40.2925	-20.00	PASS
	8149.8750	-43.0241	-20.00	PASS
	6979.4930	-38.0000	-20.00	PASS
	2444.9630	-36.4491	-20.00	PASS

Digital: 814.9875. MHz, 12.5 kHz Channel Spacing, Low. Power

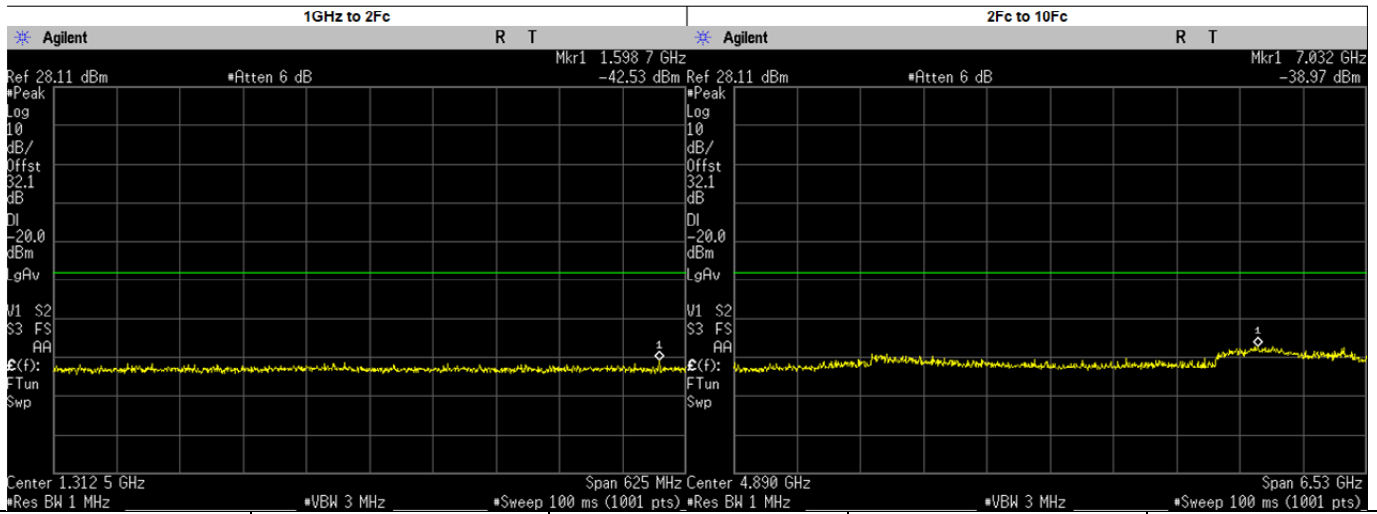
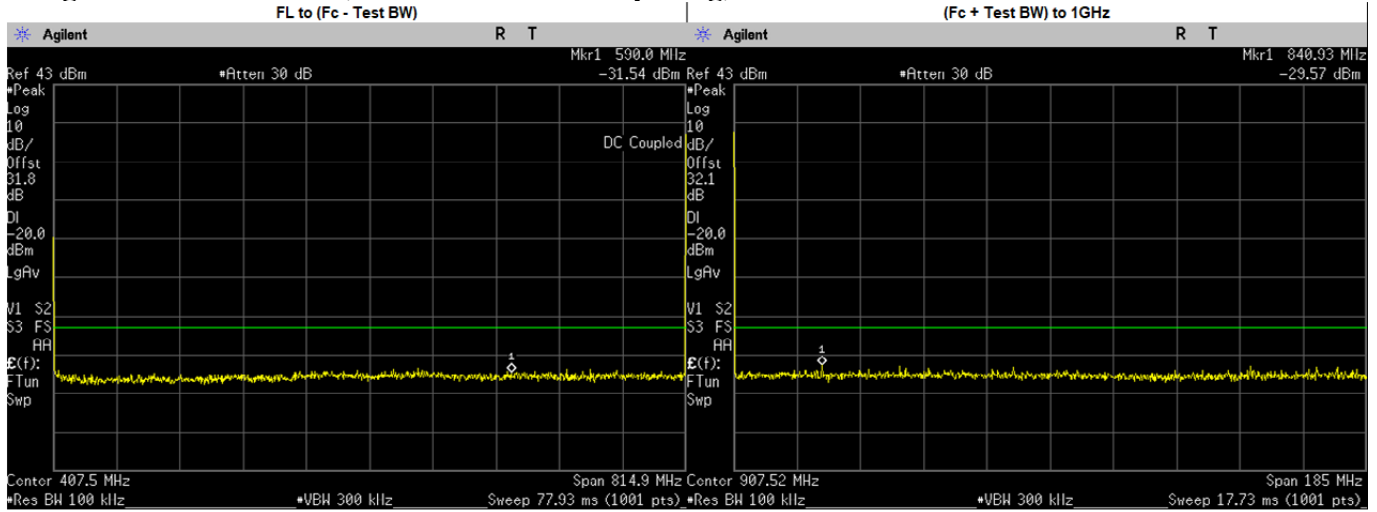

Frequency Range	Highest Spur Frequency (MHz)	Spurious Level (dBm)	Failing Limit (dBm)	Results
FL to (Fc - Test BW)	590.0000	-31.5420	-20.00	PASS
(Fc + Test BW) to 1GHz	840.9322	-29.5700	-20.00	PASS
1GHz to 2Fc	1598.7260	-42.5300	-20.00	PASS
2Fc to 10Fc	7032.0000	-38.9700	-20.00	PASS
	2444.9630	-44.5461	-20.00	PASS
	3259.9500	-42.8545	-20.00	PASS
	4074.9370	-44.3980	-20.00	PASS
	4889.9250	-44.7240	-20.00	PASS
	5704.9130	-43.3274	-20.00	PASS
	6519.9000	-43.7978	-20.00	PASS
	7334.8870	-41.1223	-20.00	PASS
	8149.8750	-42.3995	-20.00	PASS
	7031.7320	-38.9700	-20.00	PASS

Digital: 823.9875. MHz, 12.5 kHz Channel Spacing, Max. Power

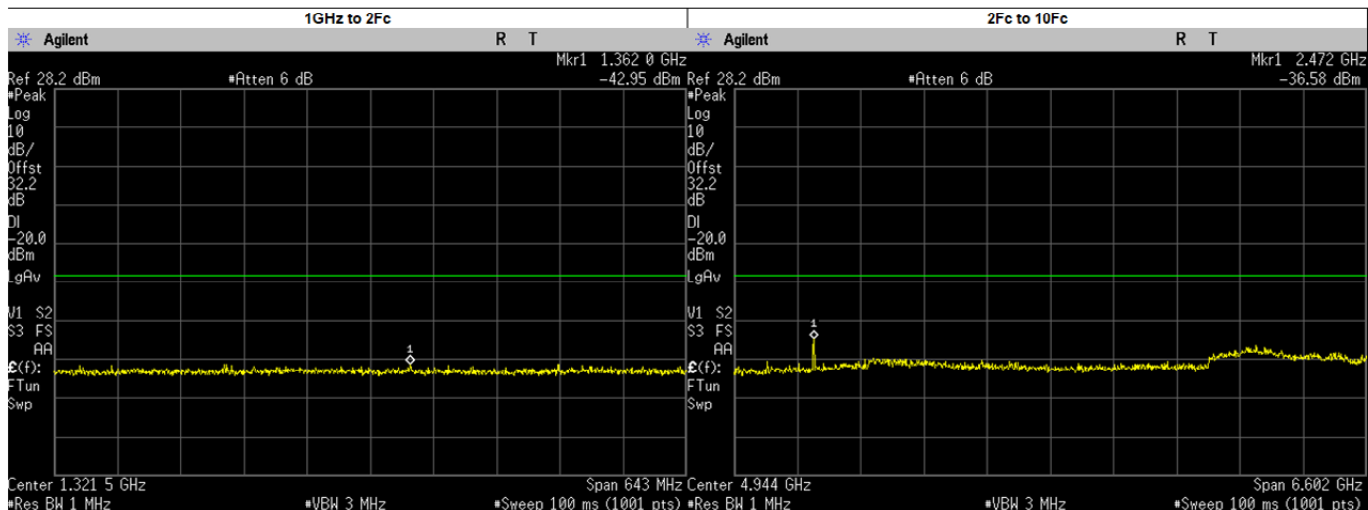
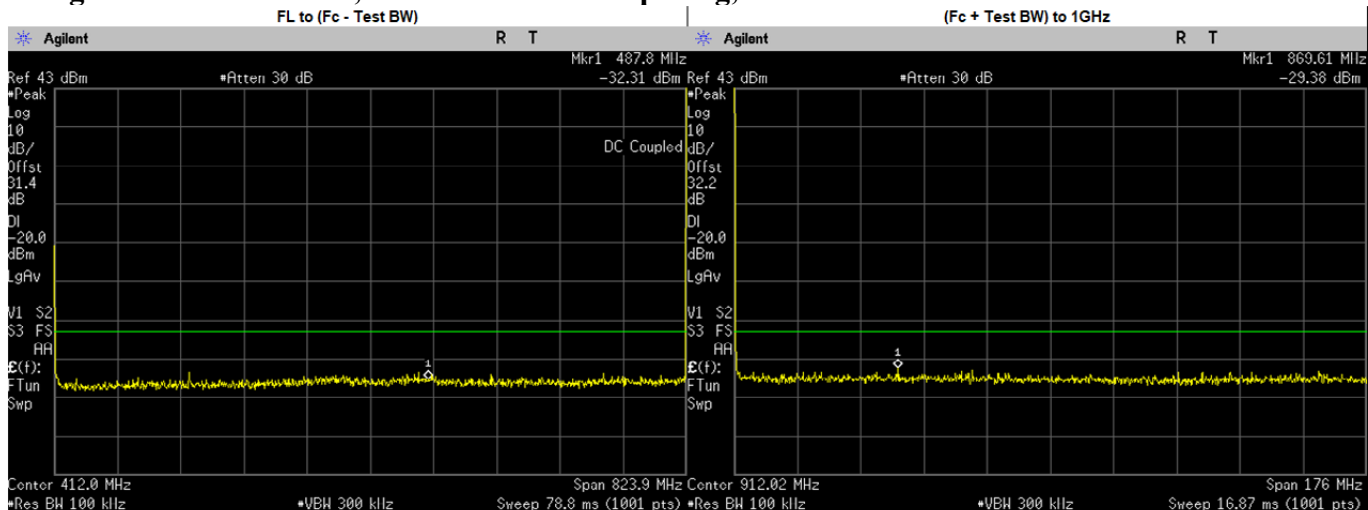

Frequency Range	Highest Spur Frequency (MHz)	Spurious Level (dBm)	Failing Limit (dBm)	Results
FL to (Fc - Test BW)	487.8000	-32.3110	-20.00	PASS
(Fc + Test BW) to 1GHz	869.6118	-29.3800	-20.00	PASS
1GHz to 2Fc	1361.9950	-42.9500	-20.00	PASS
2Fc to 10Fc	2472.0000	-36.5800	-20.00	PASS
	3295.9500	-43.3251	-20.00	PASS
	4119.9370	-43.9091	-20.00	PASS
	4943.9250	-44.2530	-20.00	PASS
	5767.9130	-43.8132	-20.00	PASS
	6591.9000	-43.3794	-20.00	PASS
	7415.8870	-41.0530	-20.00	PASS
	8239.8750	-41.7861	-20.00	PASS
	7096.1440	-37.9900	-20.00	PASS
	2471.9630	-37.4210	-20.00	PASS

Digital: 823.9875. MHz, 12.5 kHz Channel Spacing, Low. Power

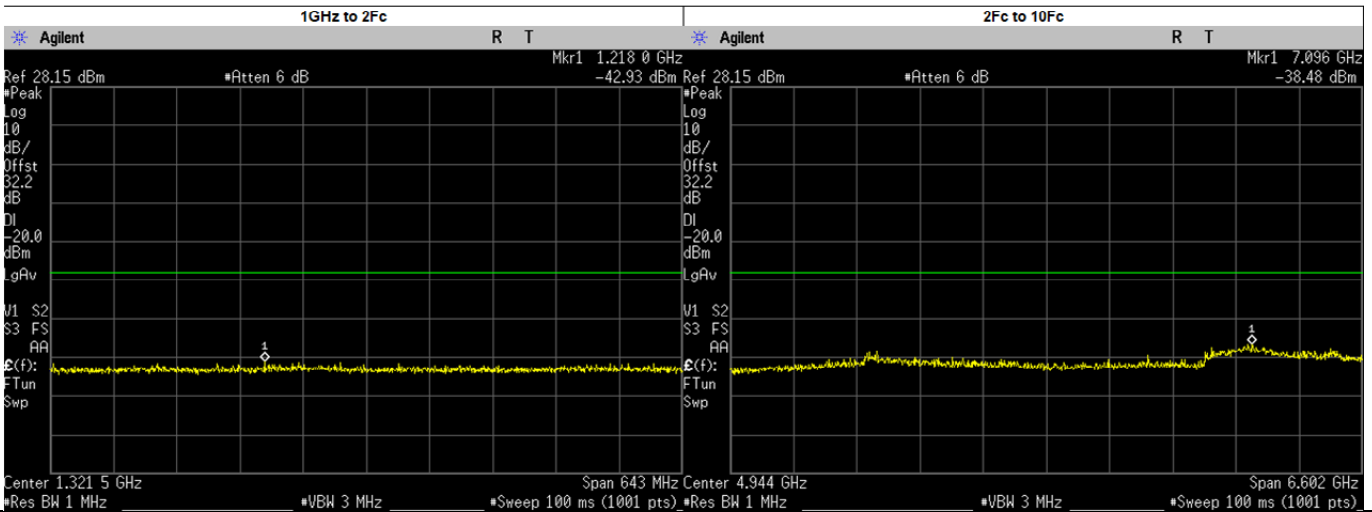
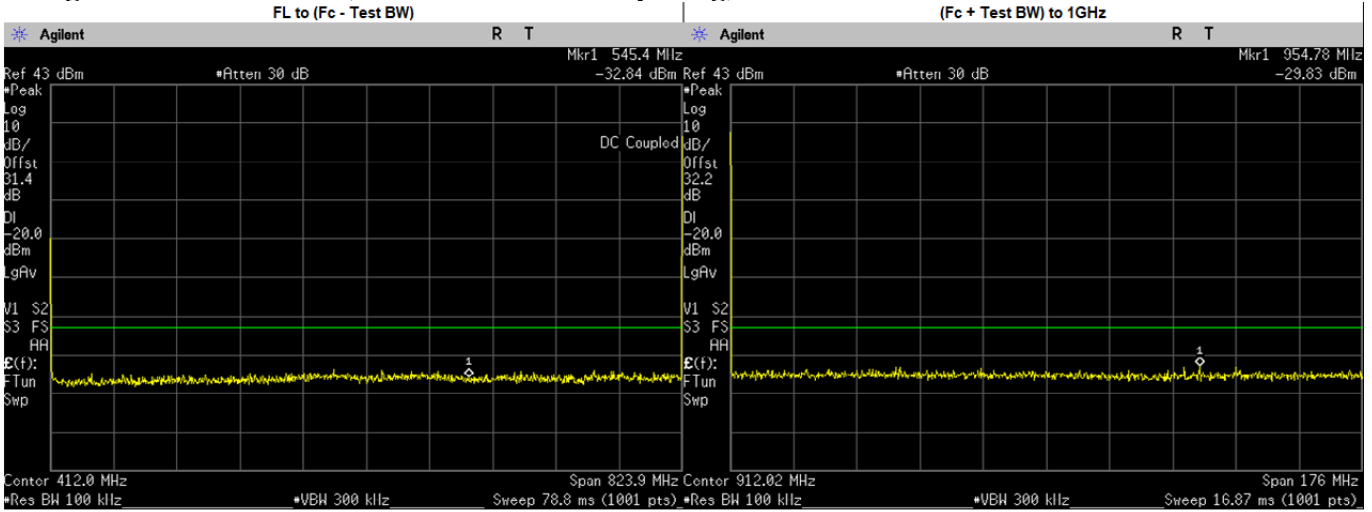

Frequency Range	Highest Spur Frequency (MHz)	Spurious Level (dBm)	Failing Limit (dBm)	Results
FL to (Fc - Test BW)	545.4000	-32.8380	-20.00	PASS
(Fc + Test BW) to 1GHz	954.7776	-29.8200	-20.00	PASS
1GHz to 2Fc	1217.9680	-42.9300	-20.00	PASS
2Fc to 10Fc	7096.0000	-38.7800	-20.00	PASS
	2471.9630	-44.5009	-20.00	PASS
	3295.9500	-42.7355	-20.00	PASS
	4119.9370	-43.2595	-20.00	PASS
	4943.9250	-44.3610	-20.00	PASS
	5767.9130	-43.5094	-20.00	PASS
	6591.9000	-43.5451	-20.00	PASS
	7415.8870	-40.7339	-20.00	PASS
	8239.8750	-42.3768	-20.00	PASS
	7096.1440	-38.4800	-20.00	PASS

Digital: 851.0125. MHz, 12.5 kHz Channel Spacing, Max. Power

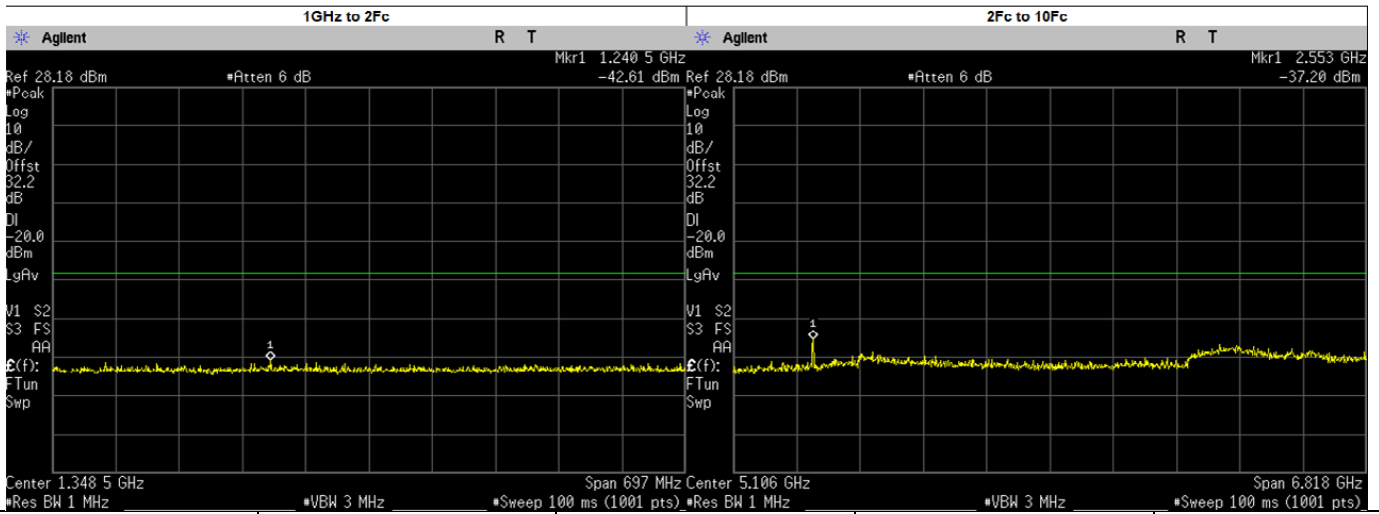
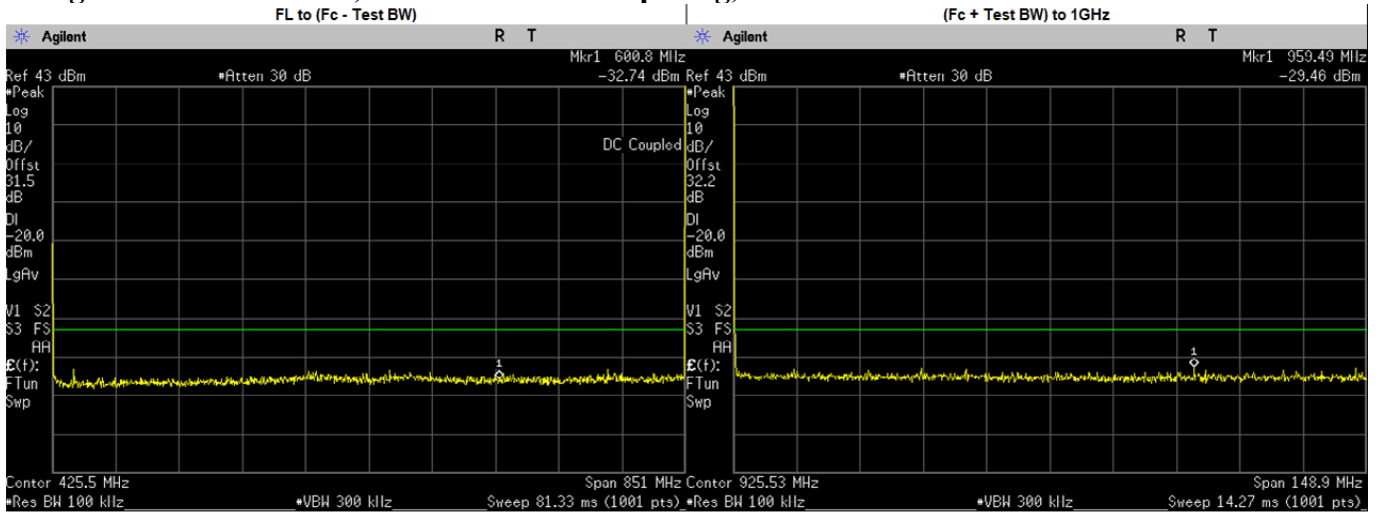

Frequency Range	Highest Spur Frequency (MHz)	Spurious Level (dBm)	Failing Limit (dBm)	Results
FL to (Fc - Test BW)	600.8000	-32.7410	-20.00	PASS
(Fc + Test BW) to 1GHz	959.4890	-29.4600	-20.00	PASS
1GHz to 2Fc	1240.4740	-42.6100	-20.00	PASS
2Fc to 10Fc	2553.0000	-37.2000	-20.00	PASS
	3404.0500	-42.7441	-20.00	PASS
	4255.0620	-43.3641	-20.00	PASS
	5106.0750	-44.6840	-20.00	PASS
	5957.0870	-43.3408	-20.00	PASS
	6808.1000	-40.5237	-20.00	PASS
	7659.1130	-40.8741	-20.00	PASS
	8510.1250	-42.2033	-20.00	PASS
	6933.3260	-38.4500	-20.00	PASS
	2553.0370	-37.8839	-20.00	PASS

Digital: 851.0125. MHz, 12.5 kHz Channel Spacing, Low. Power

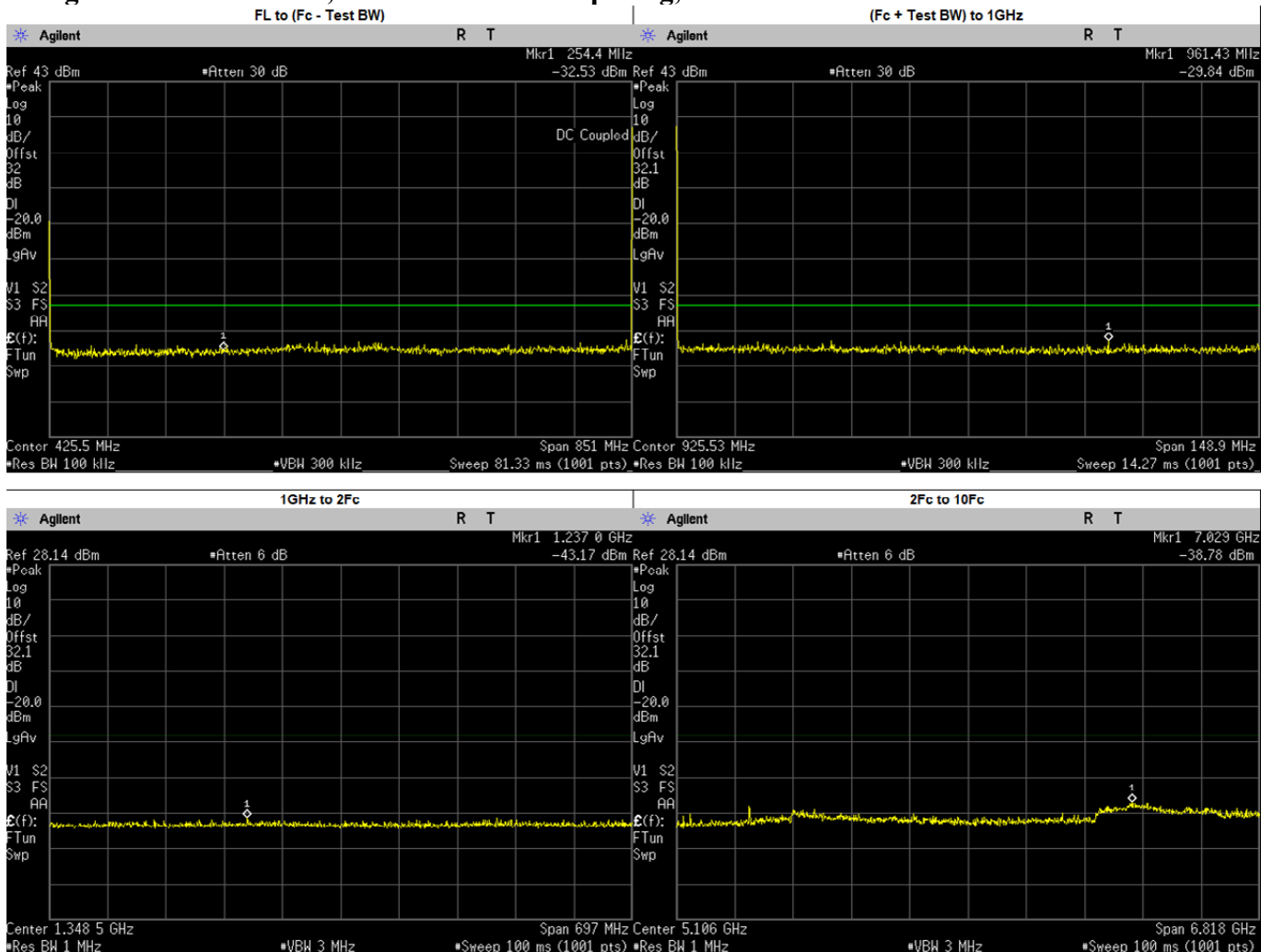

Frequency Range	Highest Spur Frequency (MHz)	Spurious Level (dBm)	Failing Limit (dBm)	Results
FL to (Fc - Test BW)	254.4000	-32.5340	-20.00	PASS
(Fc + Test BW) to 1GHz	961.4252	-29.8400	-20.00	PASS
1GHz to 2Fc	1236.9880	-43.1700	-20.00	PASS
2Fc to 10Fc	7029.0000	-38.7800	-20.00	PASS
	2553.0370	-40.7101	-20.00	PASS
	3404.0500	-43.4943	-20.00	PASS
	4255.0620	-42.7373	-20.00	PASS
	5106.0750	-44.0410	-20.00	PASS
	5957.0870	-43.7661	-20.00	PASS
	6808.1000	-41.0677	-20.00	PASS
	7659.1130	-40.1676	-20.00	PASS
	8510.1250	-42.6661	-20.00	PASS
7028.7790	-38.7800	-20.00	PASS	

Digital: 860.0125. MHz, 12.5 kHz Channel Spacing, Max. Power

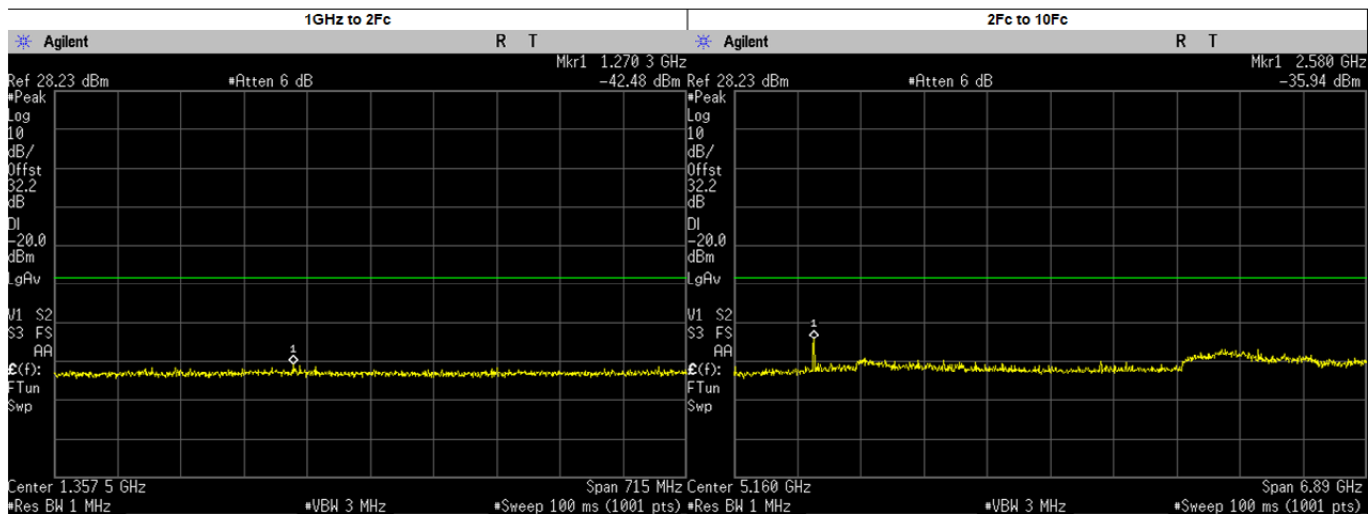
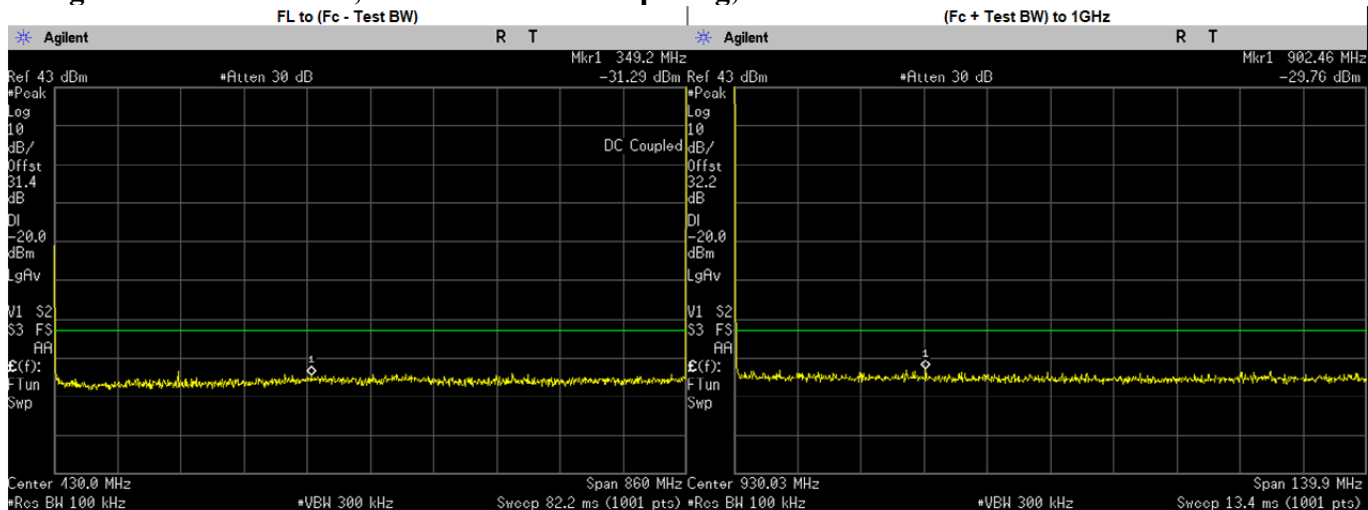

Frequency Range	Highest Spur Frequency (MHz)	Spurious Level (dBm)	Failing Limit (dBm)	Results
FL to (Fc - Test BW)	349.2000	-31.2920	-20.00	PASS
(Fc + Test BW) to 1GHz	902.4636	-29.7600	-20.00	PASS
1GHz to 2Fc	1270.2790	-42.4800	-20.00	PASS
2Fc to 10Fc	2580.0000	-35.9400	-20.00	PASS
	3440.0500	-43.0086	-20.00	PASS
	4300.0620	-43.1586	-20.00	PASS
	5160.0750	-44.6990	-20.00	PASS
	6020.0870	-43.6802	-20.00	PASS
	6880.1000	-40.2571	-20.00	PASS
	7740.1130	-40.9929	-20.00	PASS
	8600.1250	-41.5506	-20.00	PASS
	2576.2870	-37.7700	-20.00	PASS
2580.0370	-36.7754	-20.00	PASS	

Digital: 860.0125. MHz, 12.5 kHz Channel Spacing, Low. Power

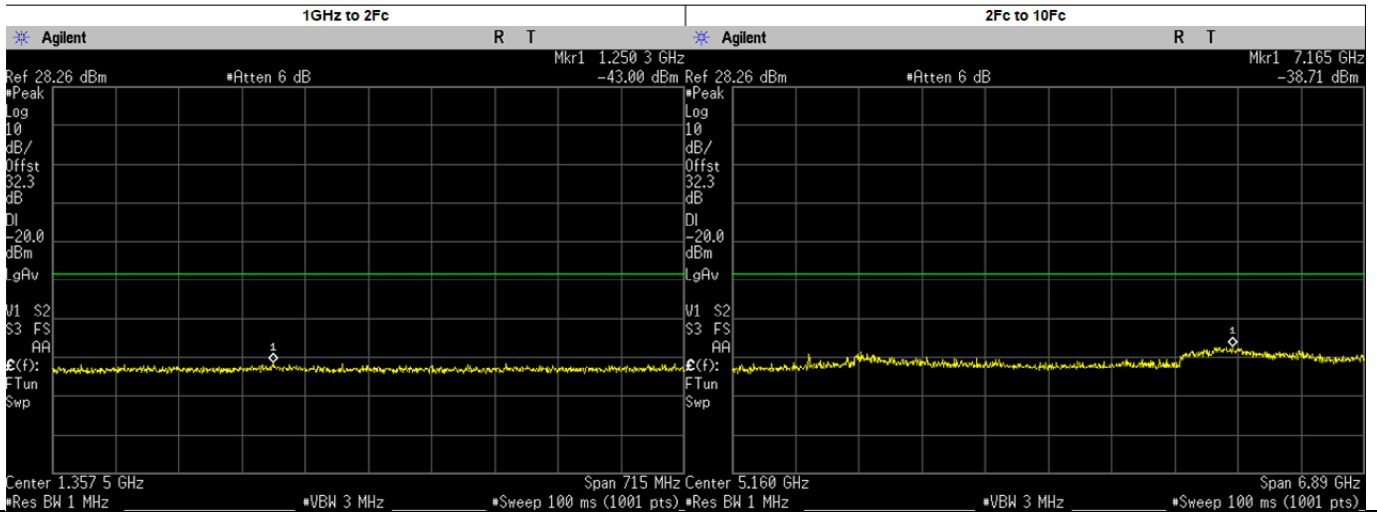
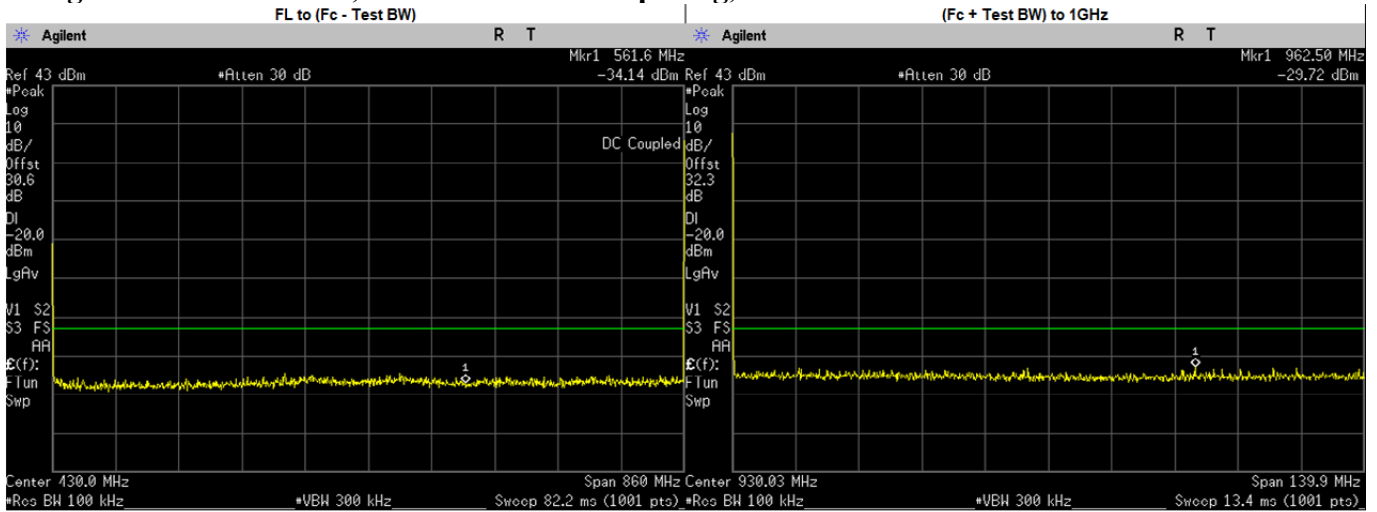

Frequency Range	Highest Spur Frequency (MHz)	Spurious Level (dBm)	Failing Limit (dBm)	Results
FL to (Fc - Test BW)	561.6000	-34.1440	-20.00	PASS
(Fc + Test BW) to 1GHz	962.4968	-29.7200	-20.00	PASS
1GHz to 2Fc	1250.2590	-43.0000	-20.00	PASS
2Fc to 10Fc	7165.0000	-38.7100	-20.00	PASS
	2580.0370	-43.7281	-20.00	PASS
	3440.0500	-42.5963	-20.00	PASS
	4300.0620	-43.2039	-20.00	PASS
	5160.0750	-45.0770	-20.00	PASS
	6020.0870	-42.9943	-20.00	PASS
	6880.1000	-40.4507	-20.00	PASS
	7740.1130	-41.0160	-20.00	PASS
	8600.1250	-42.3641	-20.00	PASS
	7165.0940	-38.7100	-20.00	PASS

Digital: 868.8875. MHz, 12.5 kHz Channel Spacing, Max. Power

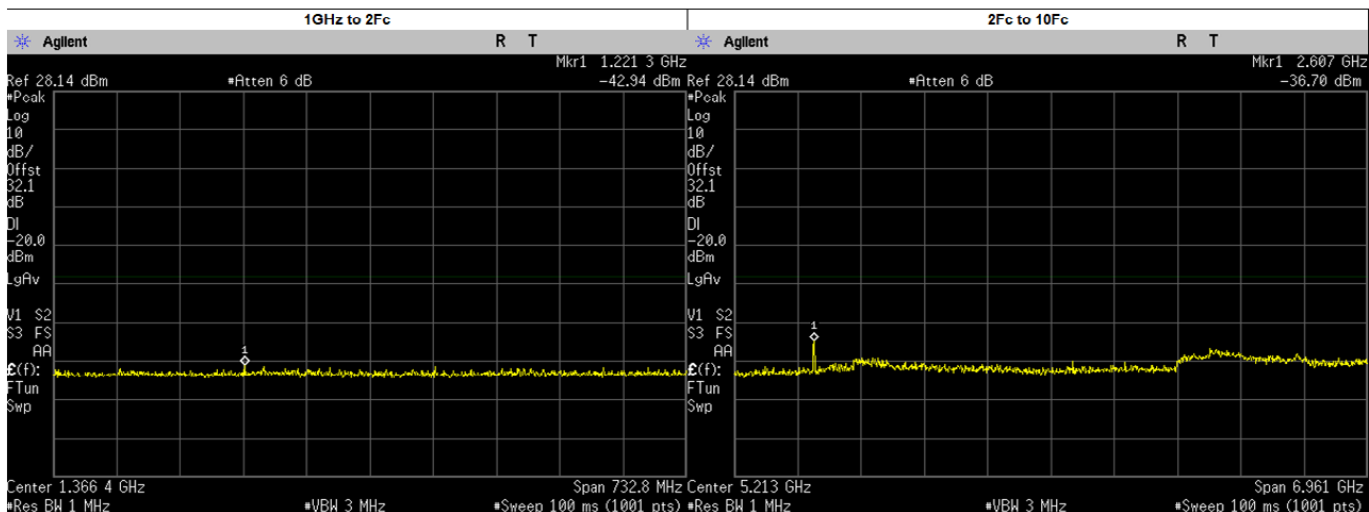
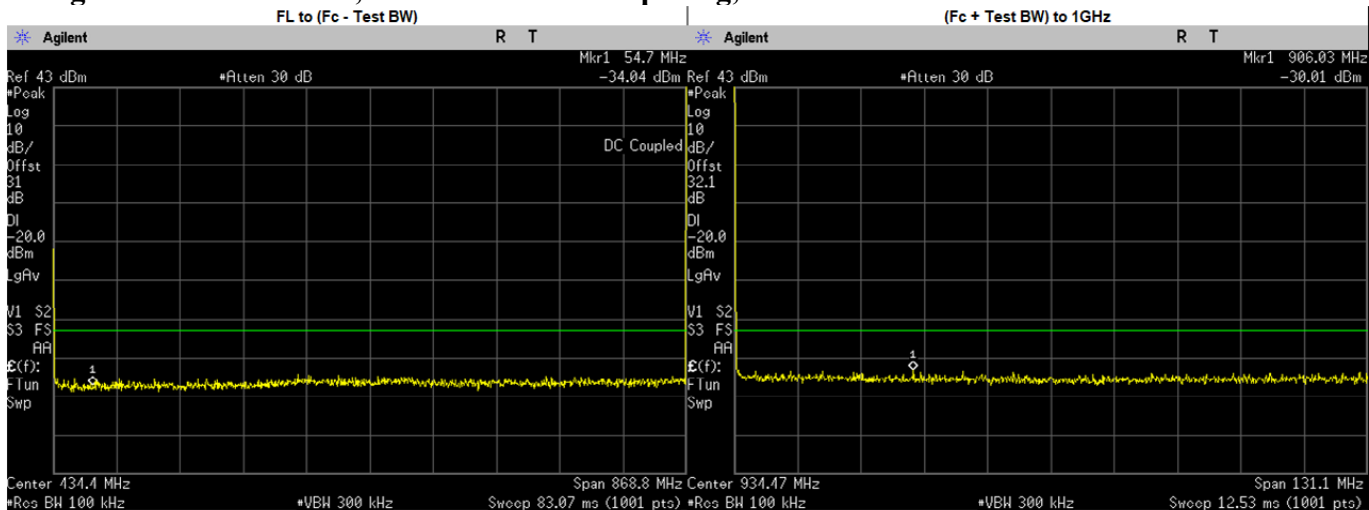

Frequency Range	Highest Spur Frequency (MHz)	Spurious Level (dBm)	Failing Limit (dBm)	Results
FL to (Fc - Test BW)	54.7000	-34.0370	-20.00	PASS
(Fc + Test BW) to 1GHz	906.0282	-30.0100	-20.00	PASS
1GHz to 2Fc	1221.2980	-42.9400	-20.00	PASS
2Fc to 10Fc	2607.0000	-36.7000	-20.00	PASS
	3475.5500	-43.2228	-20.00	PASS
	4344.4370	-44.2733	-20.00	PASS
	5213.3250	-44.5150	-20.00	PASS
	6082.2120	-43.6385	-20.00	PASS
	6951.1000	-40.8623	-20.00	PASS
	7819.9880	-41.2192	-20.00	PASS
	8688.8750	-42.4084	-20.00	PASS
	2602.9120	-38.0000	-20.00	PASS
2606.6620	-37.2992	-20.00	PASS	