 MS ISO/IEC 17025 TESTING SAMM No. 0825
MOTOROLA PENANG ADV. COMM. LABORATORY Motorola Solutions Malaysia Sdn Bhd Innoplex Plot 2A, Medan Bayan Lepas, Mukim 12 S.W.D, 11900 Bayan Lepas, Penang, Malaysia.	FCC / ISED TEST REPORT (Part 4 of 5) Report Revision : Rev.B
<p>Date/s Tested : 18-APR-2018 - 10-JUN-2018 Report Issue Date : 30-JUL-2018 Manufacturer/Location : Motorola Solutions Malaysia Sdn Bhd Requestor : FEEMSTER MICHAEL Product Type : Mobile Model Number : M37TXS9PW1AN Frequency Band : 762-806 MHz Low / Max RF Output Power : 1 Watts / 36 Watts Applicant Name : Motorola Solutions Malaysia Sdn Bhd Applicant Address : Innoplex Plot 2A, Medan Bayan Lepas, Mukim 12 S.W.D, 11900 Bayan Lepas, Penang, Malaysia ISED Registrations : 109AK FCC Test Firm Registrations : 461337</p> <p>The equipment was tested accordance to the requirement listed below:</p> <p>(LMR) FCC 47 CFR Part 90 PASS ISED RSS- Gen / 119</p>	
<p>This report shall not be reproduced without written approval from an officially designated representative of the Motorola Penang Adv. Comm. Laboratory. The results and statements contained in this report pertain only to the device(s) evaluated.</p>	
<p>Prepared By:</p> <hr/> <p>Khor Wei Loong Test Personnel</p>	<p>Approved By:</p> <hr/> <p>Vincent Foong Responsible Engineer</p>

Table of Contents

Report Revision History	3
1.0 General Information.....	4
2.0 Summary of Test Results	5
3.0 Measurement Uncertainty.....	6
4.0 Equipment List.....	7
5.0 Test Condition.....	9
5.1. Transmitter Test Conditions	9
6.0 Transmitter Test Parameters	10
6.1. RF Output Power	10
6.1.1. Test Setup.....	10
6.1.2. Test Result	10
6.2. Frequency Stability	11
6.2.1. Test Setup.....	11
6.2.2. Test Result	12
6.2.3. Test Limit.....	13
6.3. Audio Frequency Response	14
6.3.1. Test Setup.....	14
6.3.2. Test Result	15
6.3.3. Test Limit.....	16
6.4. Audio Low Pass Filter Response	17
6.4.1. Test Setup.....	17
6.4.2. Test Result	18
6.4.3. Test Limit.....	19
6.5. Modulation Limiting.....	20
6.5.1. Test Setup.....	20
6.5.2. Test Result	21
6.5.3. Test Limit.....	21
6.6. Occupied Bandwidth.....	22
6.6.1. Test Setup (Analog)	22
6.6.2. Test Result (Analog).....	22
6.6.3. Test Setup (Digital).....	23
6.6.4. Test Result (Digital).....	23
6.6.5. Test Limit.....	23
6.7. Band Edge Conducted Spurious Emission (Part 22)	24
6.7.1. Test Setup (Analog)	24
6.7.2. Test Result (Analog).....	24
6.7.3. Test Setup (Digital).....	25
6.7.4. Test Result (Digital).....	25
6.7.5. Test Limit.....	25
6.8. Transient Frequency Behavior.....	26
6.8.1. Test Setup.....	26
6.8.2. Test Result	26
6.8.3. Test Limit.....	27

6.9. Adjacent Channel Power.....	28
6.9.1. Test Setup (Analog)	28
6.9.2. Test Result	29
6.9.3. Test Setup (Digital).....	31
6.9.4. Test Result	32
6.9.5. Test Limit.....	40
6.10. Conducted Spurious Emission	42
6.10.1. Test Setup.....	42
6.10.2. Test Result (Analog).....	43
6.10.3. Test Result (Digital).....	58
6.10.4. Test Limit.....	80
6.11. Radiated Spurious Emission	81
6.11.1. Test Setup.....	81
6.11.2. Test Result (Analog).....	82
6.11.3. Test Result (Analog).....	97
6.11.4. Test Limit.....	127
6.12. Effective Radiated Power (ERP)	128
6.12.1. Test Setup.....	128
6.12.2. Test Result	129
6.12.3. Test Limit.....	129
6.13. GNSS (EIRP for 1559 - 1610MHz).....	130
6.13.1. Test Setup.....	130
6.13.1. Test Result	131
6.13.2. Test Limit.....	131

Report Revision History

Revision History	Description	Date	Originator
Rev. A	Initial Report	27-JUN-2018	Khor Wei Loong
Rev. B	Integrate the GNSS data	30-JUL-2018	Khor Wei Loong

1.0 General Information

EUT Description:

Technologies	Land Mobile Radio (LMR)
Modulation Type	Analog, C4FM , Phase II

General Description of Applied Standards

The EUT is a RF Product. According to the specifications of the manufacturer, the EUT is to comply with the requirements of the following standards:

ANSI C63.4-2014

ANSI C63.26-2015

2.0 Summary of Test Results

FCC General Rules Part (47CFR)	ISED General Rules Part	Test Item	Result	Remark
2.1046, 90.541	RSS-Gen, RSS-119	RF Power Output	Pass	-
2.1055, 90.213, 22.355, 74.464, 74.561	-	Frequency Stability	Pass	-
2.1047	-	Audio Frequency Response	Pass	-
2.1047	-	Audio Low Pass Filter Response	Pass	-
2.1047	-	Modulation limiting	Pass	-
-	-	Occupied Bandwidth	Pass	-
-	-	Band Edge Conducted Spurious Emission	Pass	-
-	-	Transient Frequency Behavior	Pass	-
90.543	RSS-119	Adjacent Channel Power	Pass	-
2.1051, 90.210	RSS-Gen, RSS-119	Conducted Spurious Emissions	Pass	Highest Spur Level -27.28dBm
2.1053, 90.210	RSS-Gen, RSS-119	Radiated Spurious Emission	Pass	Highest Spur Level -27.55dBm
-	-	GNSS (EIRP for 1559 – 1610MHz)	NA	
-	-	Effective Radiated Power (ERP)	NA	

NA → Not Applicable

3.0 Measurement Uncertainty

Measurement	Frequency	Expanded Uncertainty (k=1.96) (±)
AC Power Line Conducted Spurious Emission	150KHz ~ 30MHz	3.43
Radiated Emissions up to 1 GHz	30MHz ~ 200MHz	5.01
	200MHz ~ 1000MHz	5.01
Radiated Emissions above 1 GHz	1GHz ~ 18GHz	5.01
	18GHz ~ 25GHz	5.01

4.0 Equipment List

FCC Analog ATE#1: (SW version: 2.4.5 & FCC_Frequency Stability 1.0.3 rev.)

Description	Model	Serial Number	Calibration Date	Calibration Due Date
Audio Analyzer	8903B	3011A10475	2-May-17	2-Aug-18
SIGNAL GENERATOR	2042	203001/904	2-May-17	8-Mar-19
MODULATION ANALYZER	8901B	3216A03889	3-May-17	3-Apr-19
DSA	36570A	MY42506781	3-May-17	3-Aug-18
POWER SENSOR	E4412A	MY41502652	9-May-17	17-Apr-19
POWER METER	E4416A	GB41293855	9-May-17	16-Jan-19
POWER SUPPLY	6031A	2430A00146	09-Apr-18	08-Apr-19
CHAMBER	SH-641	92009188	3-Apr-18	3-Apr-19
RF TRANSCEIVER CONTROLLER	AX2007AI	NA	CNR	CNR

FCC Transient ATE #1: (SW version: FCC Transient ATE_R1.1.1)

Description	Model	Serial Number	Calibration Date	Calibration Due Date
POWER SUPPLY	6032A	2818A03549	11-May-17	3-Aug-18
POWER SENSOR	E4412A	MY41498918	9-May-17	9-Aug-18
POWER METER	E4416A	GB41293747	12-May-16	12-Aug-18
ATTENUATORS/SWITCH DRIVER	11713A	2508A10141	CNR	CNR
STEP ATTENUATOR/11dB	8494G	MY52300223	9-May-17	9-Aug-18
STEP ATTENUATOR/110dB	8496G	MY52300176	9-May-17	9-Aug-18
OSCILLOSCOPE	MSO8064A	MY45001903	25-May-17	25-Aug-18
AUDIO ANALYZER	8903B	3729A17409	2-May-17	5-Dec-18
AUDIO ANALYZER	8903B	3011A08952	2-May-17	25-Nov-18
MODULATION ANALYZER	8901B	3538A05696	28-Mar-18	31-Mar-19
SIGNAL GENERATOR	8657A	3323A05725	19-May-17	19-Aug-18
SPECTRUM ANALYZER	E4440A	MY46185415	24-May-17	16-Aug-19
SWITCH CONTROL UNIT	-	-	CNR	CNR

CONDUCTED SPUR EMISSION ATE # 1 (SW version: Conducted Spur ATE_rev 1.23.01)

Description	Model	Serial Number	Calibration Date	Calibration Due Date
SWITCH CONTROL UNIT	3488A	2719A32735	CNR	CNR
SPECTRUM ANALYZER	E4440A	US45303111	16-Feb-17	16-Feb-19
POWER SUPPLY	6032A	MY41002067	5-May-17	5-Aug-18
HIGH PASS FILTER SWITCH BOX	-	CS001	9-Apr-18	9-Apr-19
MICROWAVE GENERATOR	SMP04	100146	18-Sept-17	18-Sept-18
MODULATION ANALYZER	8901B	3438A05278	3-May-17	3-Aug-18

Radiated Emission Station (SW version: EMC_FCC_IC_Bluetooth_RE_Test_v1.5.1)

DESCRIPTION	MODEL	SERIAL NUMBER	CALIBRATION DATE	CALIBRATION DUE DATE
DRG HORN FREQ.	SAS-571	719	18-Jul-17	18-Jul-19
DRG HORN FREQ.	SAS-571	720	2-Mar-17	2-Mar-19
POWER SUPPLY	6032A	2615A01178	6-Jun-17	6-Jun-18
MICROWAVE SIGNAL GENERATOR	SMP04	100127	19-Jul-17	18-Jul-18
EMI TEST RECEIVER	ESIB26	100336	13-Jul-17	12-Jul-18
SIGNAL ANALYZER	FSV40	101103	18-Jul-17	17-Jul-18
5m Semi-anechoic Chamber	S800-HX	J2308	No Cal. Req'd	No Cal. Req'd
BILOG ANTENNA	CBL6112D	25224	22-Jul-17	22-Jul-18
BILOG ANTENNA	CBL6112B	2964	16-Feb-18	16-Feb-20
BROAD-BAND HORN ANTENNA	BBHA9170	BBHA9170255	7-Nov-17	7-Nov-18
DATA LOGGER	SDL500	A.016776	18-Mar-17	18-Mar-19
LOOP ANTENNA	6502	208416	27-Jul-17	27-Jul-18
SYSTEM CONTROLLER	SC104V	050806-1	CNR	CNR
TURNTABLE FLUSH MOUNT 2M	FM2011	NA	CNR	CNR
ANTENNA POSITIONING TOWER	TLT2	NA	CNR	CNR
18 - 40GHz PREAMPLIFIER	Miteq Hi Gain Sucoflex	002	CNR	CNR
PREAMPLIFIER	PAM-0118P	361	CNR	CNR
Test Software	EMC FCC IC Bluetooth RE Test			
Version	EMC FCC RE v1.5.1			

CNR → Calibration Not Required

5.0 Test Condition

5.1. Transmitter Test Conditions

Test Item, (Channel Spacing)	Power (W)	Modulation	Test Frequency (MHz)	Tested By
RF Output Power	Low & Max	Analog	762.0125, 768.0125, 769.0125, 769.0875, 774.8875, 775.9875, 798.0125, 799.0875, 804.9125, 805.9875	Khor Wei Loong
Frequency Stability	Max	Analog	769.0875	Khor Wei Loong
Audio Frequency Response (12.5kHz)	Max	Analog	769.0875	Khor Wei Loong
Audio Low Pass Filter Response (12.5kHz)	Max	Analog	769.0875	Khor Wei Loong
Modulation limiting (12.5kHz)	Max	Analog	769.0875	Khor Wei Loong
Occupied Bandwidth (12.5kHz / 20kHz / 25kHz)	Max	Analog	NA	NA
Band Edge Conducted Spurious Emissions (Part 22) (12.5kHz / 20kHz / 25kHz)	Max	Analog	NA	NA
Transient Frequency Behavior (UHF & VHF Band) (12.5kHz / 25kHz)	Max	Analog	NA	NA
Adjacent Channel Power (700MHz Band) (12.5kHz / 25kHz)	Max	Analog, C4FM	769.0875, 774.8875, 799.0875, 804.9125	Khor Wei Loong
Conducted Spurious Emissions- (12.5kHz)	Low / Max	Analog, C4FM, Phase II	762.0125, 764.0125, 769.0125, 769.0875, 774.8875, 792.0125, 799.0875, 804.9125	Khor Wei Loong
Radiated Spurious Emission (12.5kHz)	Low / Max	Analog, C4FM, Phase II	762.0125, 764.0125, 769.0125, 769.0875, 774.8875, 792.0125, 799.0875, 804.9125	Nazrin & Qawiman
GNSS (EIRP for 1559 - 1610MHz) (12.5kHz / 25kHz)	Max	Analog	NA	NA
Effective Radiated Power (ERP) (12.5kHz / 25kHz)	Max	Analog	NA	NA

NA → Not Applicable

6.0 Transmitter Test Parameters

6.1 RF Output Power

6.1.1 Test Setup

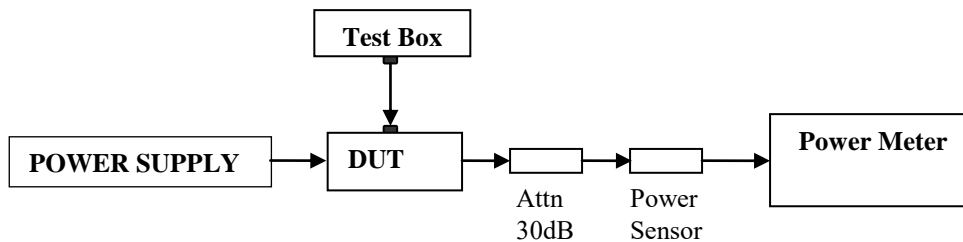

- 1) The DUT transmitter connected to Power Meter using the 30 dB attenuator and power sensor with above setup.
- 2) Path loss for the measurement included.
- 3) All the measurement was done at low, mid, high frequency for each band.
- 4) Record the power into the test report.

6.1.2 Test Result

Temperature	25°C				Remarks
Voltage (V)	13.6V				
Frequency (MHz)	Low Power (W)	Current (A)	Max Power (W)	Current (A)	
762.0125	0.95	2.93	35.13	15.23	Not for FCC Review
768.0125	0.93	2.94	35.98	14.95	Not For FCC Review
769.0125	0.91	2.93	35.42	14.99	
769.0875	0.91	2.93	35.14	15.12	
774.8875	0.92	2.86	34.97	15.22	
775.9875	0.92	2.83	34.77	14.89	Not For FCC Review
798.0125	0.91	2.88	34.68	14.89	Not For FCC Review
799.0875	0.93	2.9	35.36	14.88	
804.9125	0.92	2.9	35.56	14.89	
805.9875	0.92	2.92	35.42	15.22	Not For FCC Review

6.2. Frequency Stability

6.2.1. Test Setup

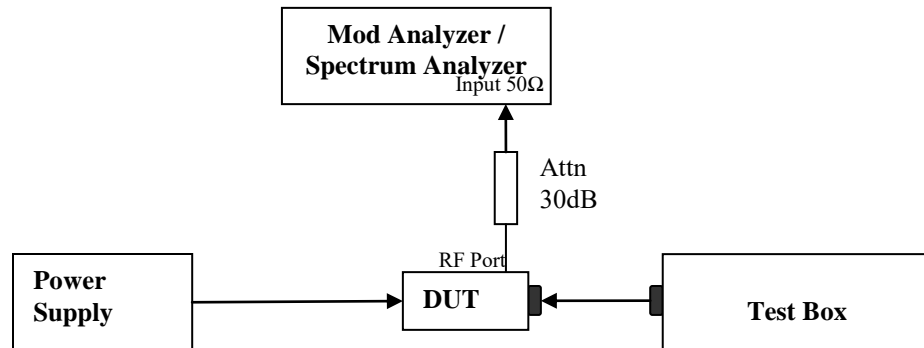

- 1) The DUT transmitter output port was connected to Modulation / Spectrum Analyzer.
- 2) Path loss for the measurement included.
- 3) Transmit the DUT and record the freq in MCF_{MHz} .
- 4) Test in 2 conditions:
 - Temperature: The frequency of the transmitter was measured from $-30^{\circ}C$ to $50^{\circ}C$.
 - Supply Voltage:
 - Mobile: The frequency of the transmitter was measured from 85% to 115% of the nominal operating input voltage.
 - Portable: The frequency of the transmitter was measured from nominal $\pm x\%$ as specified by the manufacturer
- 5) Calculate the ppm frequency error by the following:

$$ppm\ error = \left(\frac{MCF_{MHz}}{ACF_{MHz}} - 1 \right) * 10^6$$

Where: MCF_{MHz} is the Measured Carrier Frequency in MHz
 ACF_{MHz} is the Assigned Carrier Frequency in MHz

6.2.2. Test Result

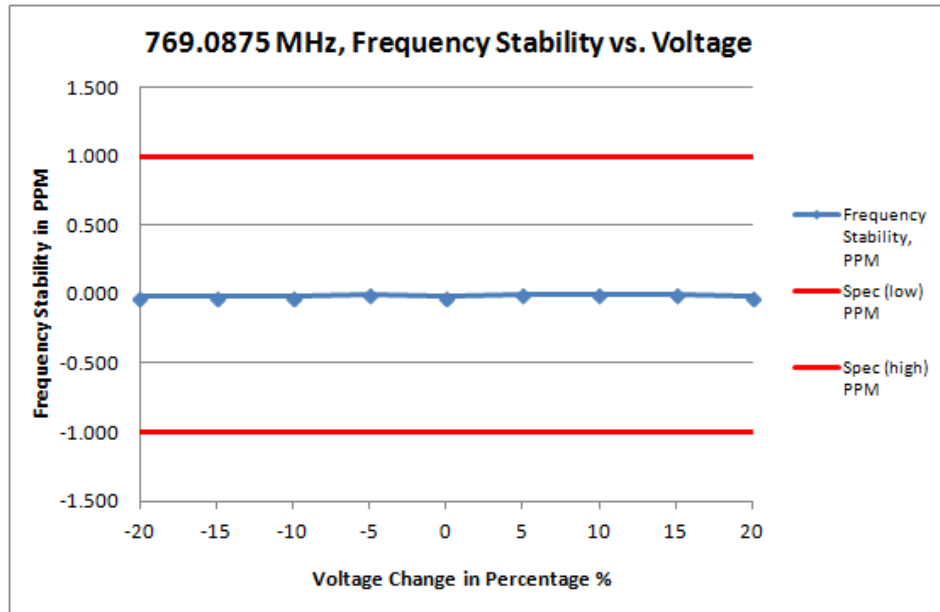

Frequency / Channel Spacing	769.0875 MHz / 12.5 kHz				
Temperature, °C	25				
Voltage %	Voltage, V	Frequency, MHz	Frequency Stability, PPM	Spec (low) PPM	Spec (high) PPM
-20	10.800	769.087490	-0.013	-1.000	1.000
-15	11.560	769.087490	-0.013	-1.000	1.000
-10	12.240	769.087490	-0.013	-1.000	1.000
-5	12.920	769.087500	0.000	-1.000	1.000
0	13.600	769.087490	-0.013	-1.000	1.000
5	14.280	769.087500	0.000	-1.000	1.000
10	14.960	769.087500	0.000	-1.000	1.000
15	15.640	769.087500	0.000	-1.000	1.000
20	16.320	769.087490	-0.013	-1.000	1.000

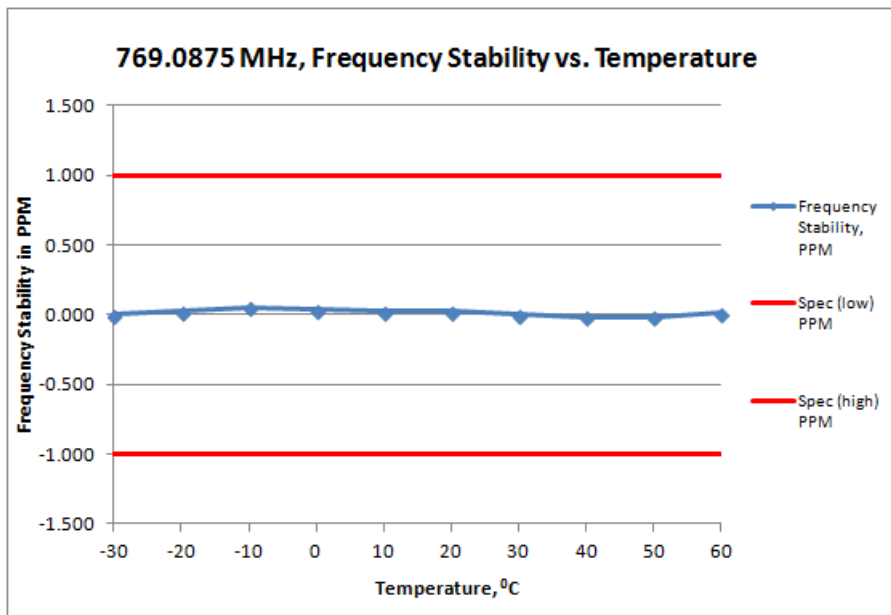

Frequency / Channel Spacing	769.0875 MHz / 12.5 kHz			
Voltage, V	13.6			
Temperature, °C	Frequency, MHz	Frequency Stability, PPM	Spec (low) PPM	Spec (high) PPM
-30	769.087500	0.000	-1.000	1.000
-20	769.087520	0.026	-1.000	1.000
-10	769.087540	0.052	-1.000	1.000
0	769.087530	0.039	-1.000	1.000
10	769.087520	0.026	-1.000	1.000
20	769.087520	0.026	-1.000	1.000
30	769.087500	0.000	-1.000	1.000
40	769.087490	-0.013	-1.000	1.000
50	769.087490	-0.013	-1.000	1.000
60	769.087510	0.013	-1.000	1.000

6.2.3. Test Limit

As per manufacturer declared spec +/- 1ppm

6.3. Audio Frequency Response

6.3.1. Test Setup

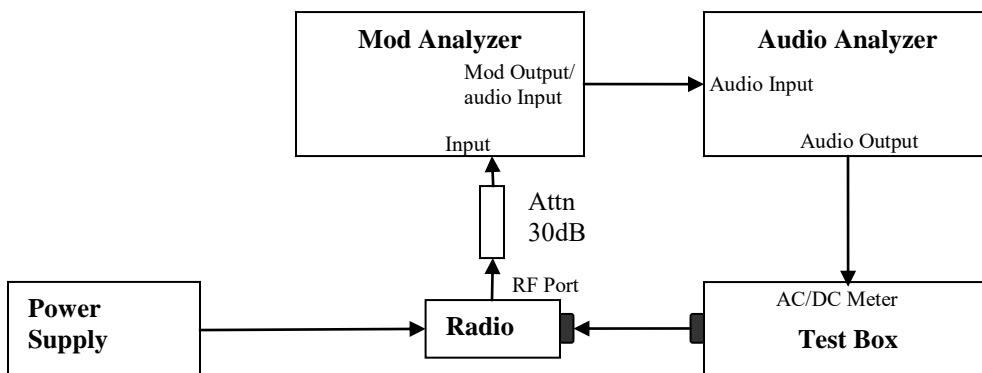

- 1) The DUT transmitter output port was connected to Modulation Analyzer.
- 2) Path loss for the measurement included.
- 3) Set the audio bandwidth filter to 15 kHz and 50 kHz.
- 4) Transmit the radio and set the audio analyzer to 1 kHz audio frequency and 20% of the Full rated system deviation.
- 5) On audio analyzer, set the rated level as reference to zero.
- 6) Vary the audio frequency from 300 Hz to 3 kHz. Record the change in dB on the audio analyzer.

6.3.2. Test Result

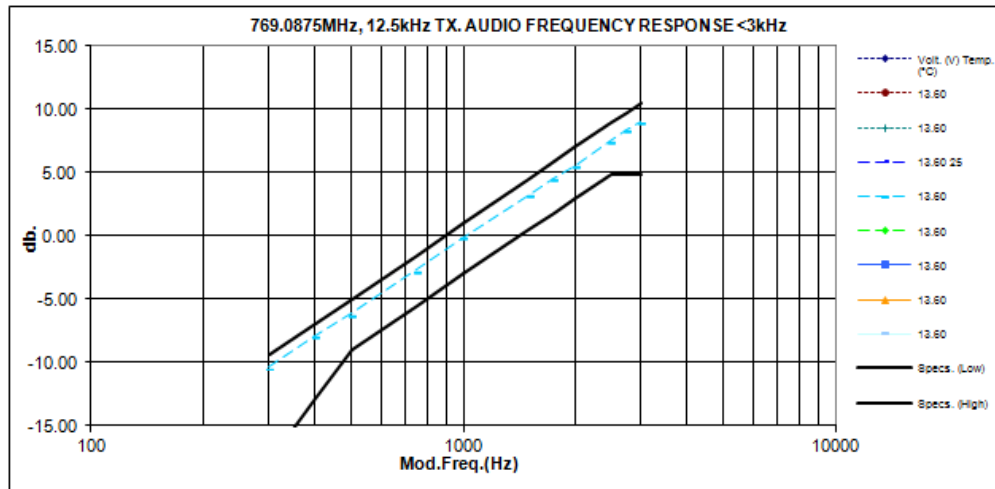

6.3.3. Test Limit

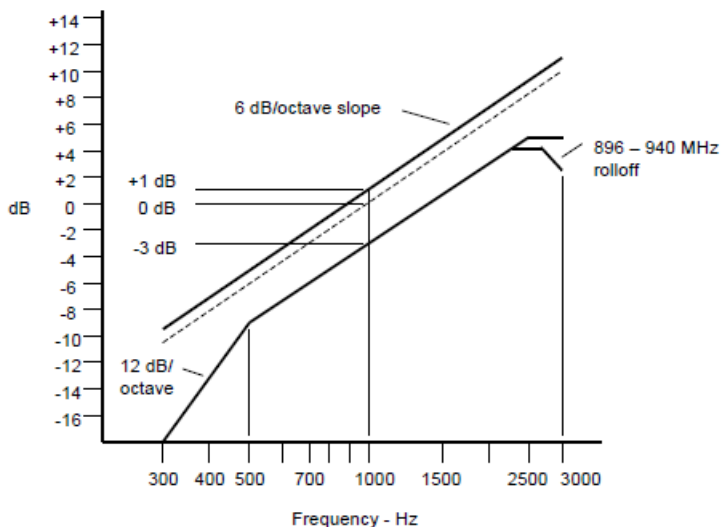

Note:

- o There are additional 6 dB per octave attenuation is allowed from 2.5KHz to 3KHz in equipment 25MHz to 869MHz radio.
- o Additional 6 dB per octave attenuation is allowed from 2.3KHz to 2.7KHz & additional 12 dB per octave attenuation is allowed from 2.7KHz to 3KHz in equipment 896MHz to 940MHz radio.

6.4. Audio Low Pass Filter Response

6.4.1. Test Setup

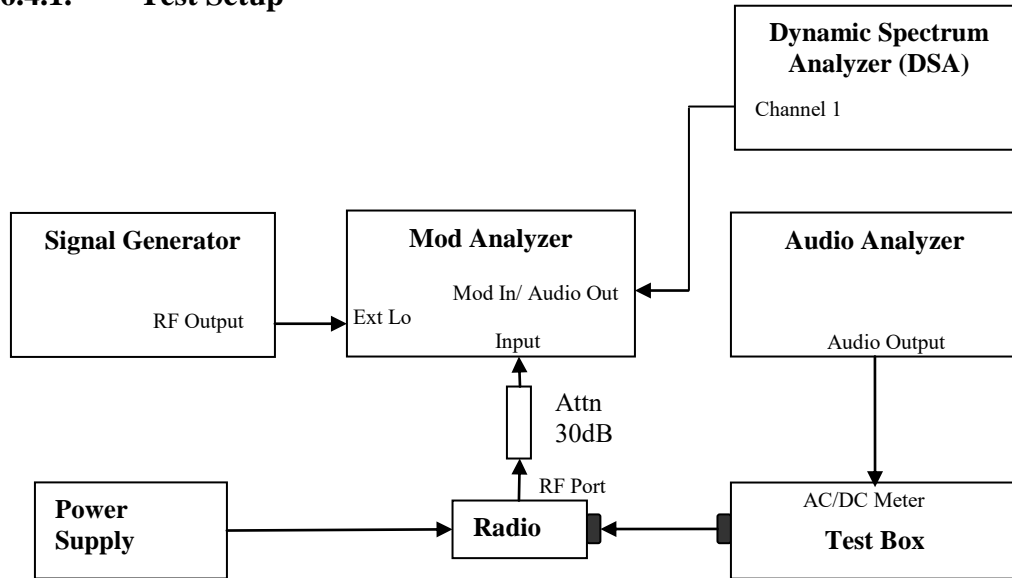

- 1) The DUT transmitter output port was connected to Modulation Analyzer.
- 2) Path loss for the measurement included.
- 3) Press 23.1SPCL on modulation analyzer to enable the external LO from Sigen.
- 4) Set the Sigen frequency to $F_c + 1.5$ MHz, RF output level to 0dBm without modulation.
- 5) Transmit the radio and set the audio analyzer to 1 kHz audio frequency and 60% of the Full rated system deviation.
- 6) Up the amplitude by 20dB.
- 7) On DSA, get the reference point to 0dB.
- 8) Vary the frequency on audio analyzer from 3 kHz to 20 kHz, record the audio tone from DSA.

6.4.2. Test Result

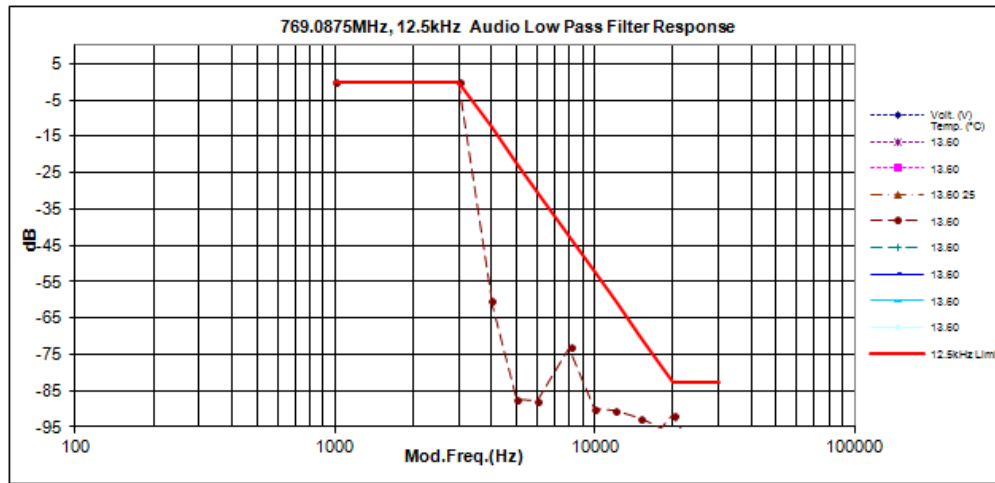

6.4.3. Test Limit

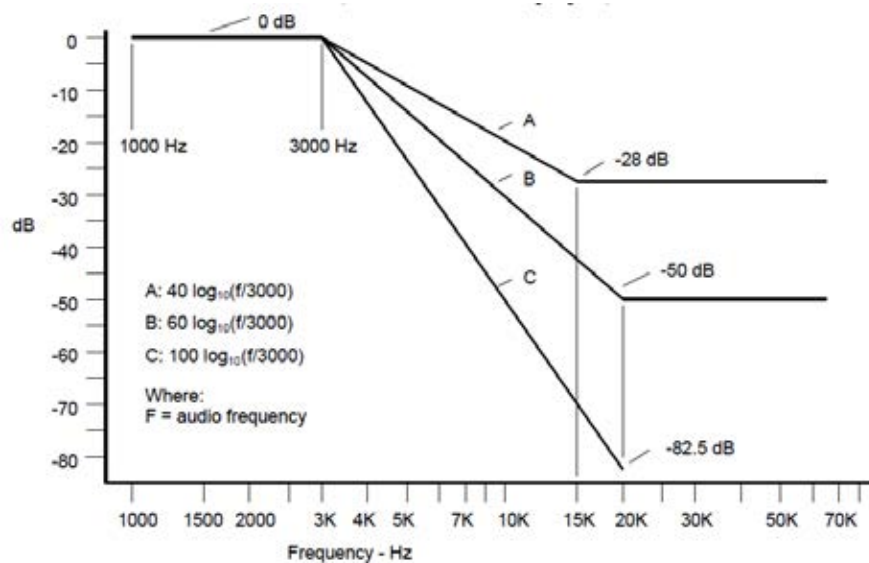

For audio frequencies above 3000 Hz, the audio response of the post limiter low-pass filter shall meet or exceed the following requirements:

- a) For equipment operating on 20, 25 or 30 kHz channel bandwidth in the 25 MHz to 174 MHz range:

At frequencies from 3000 Hz through 15,000 Hz the attenuation shall be greater than the attenuation at 1000 Hz by at least: $40 \log_{10}(f/3000)$ dB

where: f is the audio frequency in Hz.

At frequencies above 15,000 Hz, the attenuation shall be greater than the attenuation at 1000 Hz, by at least: 28 dB.

- b) For equipment operating with 25 kHz bandwidth channels between 406 and 512 MHz through 896 MHz, and between 929 MHz through 930 MHz:

At frequencies from 3000 Hz through 20,000 Hz, the attenuation shall be greater than the attenuation at 1000 Hz by at least: $60 \log_{10}(f/3000)$ dB

where: f is the audio frequency in Hz.

At frequencies above 20,000 Hz the attenuation shall be greater than the attenuation at 1000 Hz by at least: 50 dB.

- c) For equipment operating on channels between 896 MHz through 901 MHz, between 935 MHz through 940 MHz, and 12.5 or 15 kHz spaced channels in the frequency range 138-174 MHz and 406-512 MHz.

At frequencies from 3000 Hz through 20,000 Hz the attenuation shall be greater than the attenuation at 1000 Hz by at least: $100 \log_{10}(f/3000)$ dB

where: f is the audio frequency in Hz.

6.5. Modulation Limiting

6.5.1. Test Setup

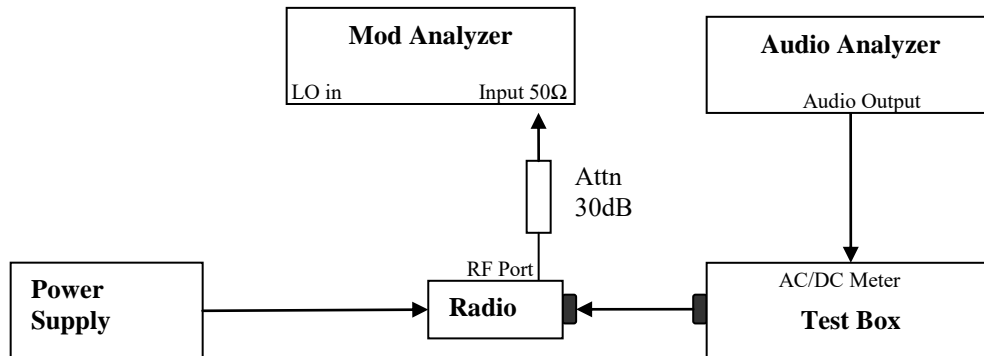

- 1) The DUT transmitter output port was connected to Modulation Analyzer.
- 2) Path loss for the measurement included.
- 3) Set the audio bandwidth filter to 15 kHz.
- 4) Transmit the radio and set the audio analyzer to 1 kHz audio frequency and 60% of the Full rated system deviation.
- 5) Record the frequency deviation as 0dB input level at 1kHz audio frequency.
- 6) Repeat the step and record the frequency deviation from -20 dB to 20dB by 5 dB increments and different audio freq 300 Hz, 2.5 kHz and 3 kHz.

6.5.2. Test Result

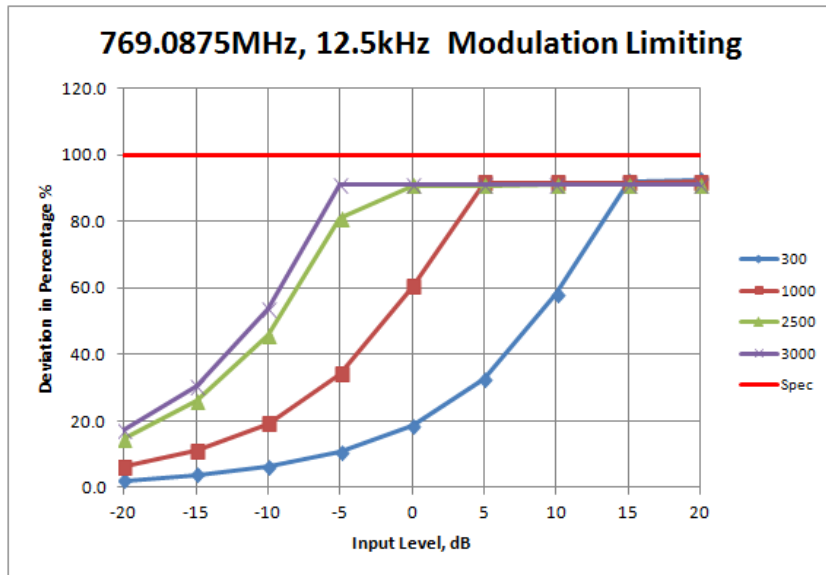

6.5.3. Test Limit

Modulation Limiting shall not exceed 100 percent.

6.6. Occupied Bandwidth

6.6.1. Test Setup (Analog)

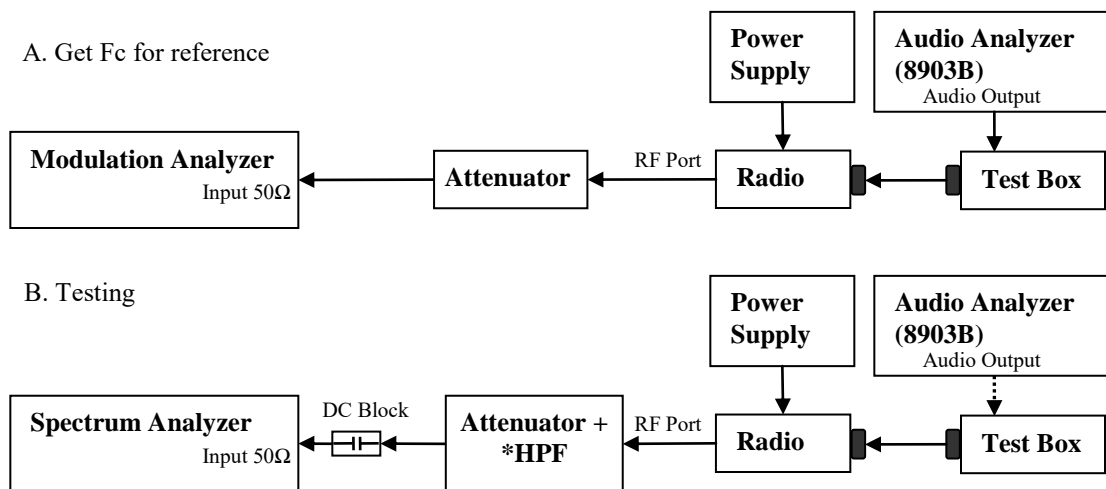

- 1) The DUT transmitter output port was connected to Modulation Analyzer.
- 2) Set the audio bandwidth filter to 15 kHz low pass filter and 50 kHz high pass filter.
- 3) Transmit the radio and set the audio analyzer to 2.5 kHz audio frequency and 50% of the rated deviation. Up the amplitude by 16 dB. Dekey the DUT.
- 4) Path loss for the measurement included.
- 5) Select the Occupied Bandwidth measurement for 99% Emissions Bandwidth Measurement.
- 6) Key in the Fc and Resolution Bandwidth (1 ~ 5 % of emission designator).
- 7) Transmit the DUT and record the occupied Bandwidth frequency.
- 8) Preset the spectrum analyzer for sideband spectrum measurement.
- 9) Set the span and Resolution Bandwidth (according to FCC/ ISED standard).
- 10) Save the screen shot as modulated signal
- 11) Remove the audio tone from audio analyzer to capture unmodulated signal.

* Only HPF added for Mask 80.211 measurement with attenuator.

6.6.2. Test Result (Analog)

Not Applicable

6.6.3. Test Setup (Digital)

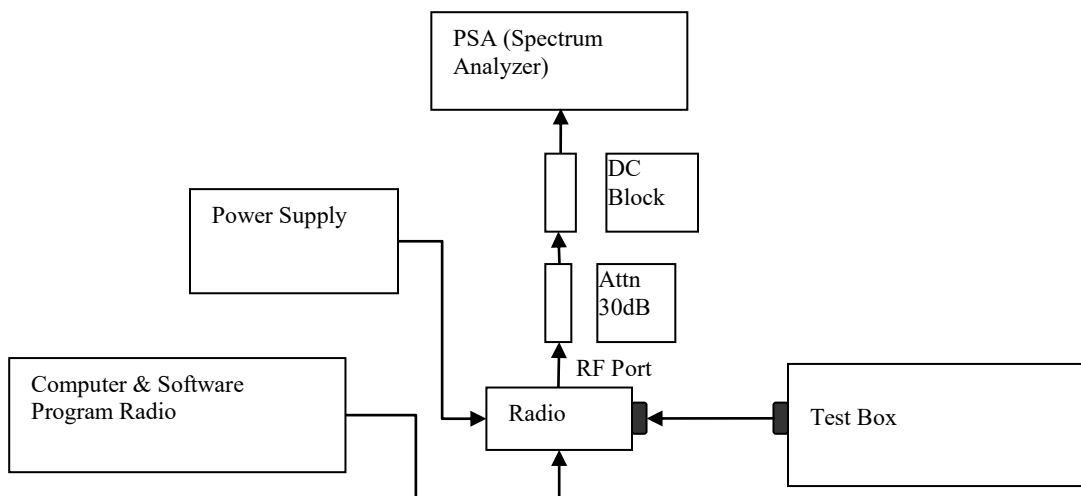

- 1) Program and set radio to operate in desire test frequency and digital mode with modulation. (*4FSK, C4FM or other digital modulation form).
- 2) Path loss for the measurement included.
- 3) Select the Occupied Bandwidth measurement for 99% Emissions Bandwidth Measurement.
- 4) Key in the Fc and Resolution Bandwidth (1 ~ 5 % of emission designator).
- 5) Transmit the DUT and record the occupied Bandwidth frequency.
- 6) Preset the spectrum analyzer for modulation emission spectrum measurement.
- 7) Set the span and Resolution Bandwidth (according to FCC/ ISED standard).
- 8) Capture the screen shot as modulated signal.

*Note:

- For Digital Modulation, 12.5 kHz Data F1D & FXD would be the same. Therefore only measurements with F1D modulation shown below.
- For Digital Modulation, 12.5 kHz Data F1E & FXE would be the same. Therefore only measurements with F1E modulation shown below.

6.6.4. Test Result (Digital)

Not Applicable

6.6.5. Test Limit

The 99% occupied bandwidth is the width of a frequency band such that, below the lower and above the upper frequency limits, the mean powers emitted are each equal to a specified percentage 0.5% of the total mean transmitted power.

6.7. Band Edge Conducted Spurious Emission (Part 22)

6.7.1. Test Setup (Analog)

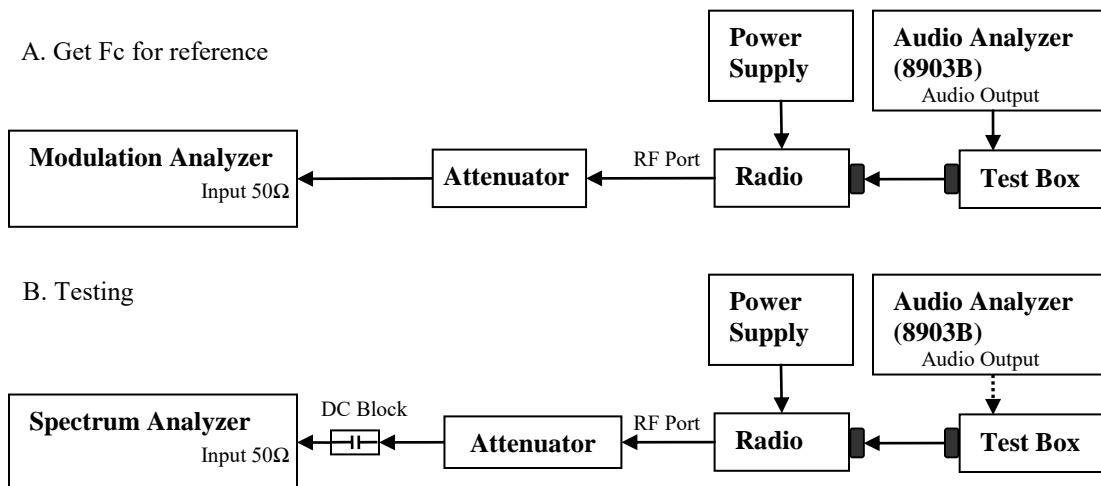

- 1) The DUT transmitter output port was connected to Modulation Analyzer.
- 2) Set the audio bandwidth filter to 15 kHz low pass filter and 50 kHz high pass filter.
- 3) Transmit the radio and set the audio analyzer to 2.5 kHz audio frequency and 50% of the rated deviation. Up the amplitude by 16 dB. Dekey the DUT.
- 4) Path loss for the measurement included.
- 5) Select the Occupied Bandwidth measurement for 99% and 26dB Emissions Bandwidth Measurement.
- 6) Key in the Fc and Resolution Bandwidth.
- 7) Transmit the DUT and record the occupied Bandwidth frequencies.
- 8) Preset the spectrum analyzer for band edge measurement.
- 9) The band edges of lowest and highest channels were measured.
- 10) Key in the Lowest and highest channel frequency, span is 60 kHz and Resolution Bandwidth is at least 1% of Emission Bandwidth.
- 11) Save the screen shot as modulated signal.
- 12) Remove the audio tone from audio analyzer to capture unmodulated signal.

*Note:

- For emission designator ending with F3E, 16K0F3E is the worst case and therefore only 16K0F3E will be shown.

6.7.2. Test Result (Analog)

Not Applicable

6.7.3. Test Setup (Digital)

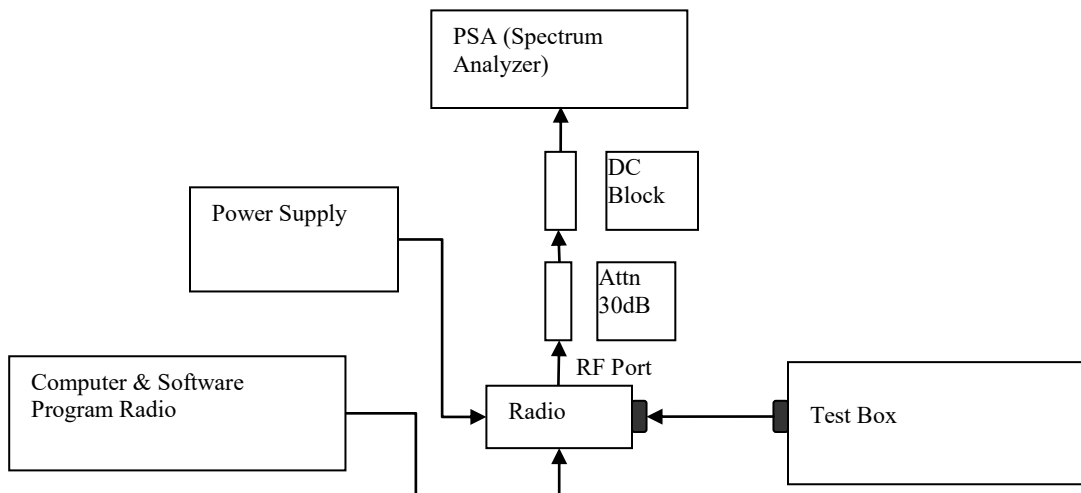

- 1) Program and set radio to operate in desire test frequency and digital mode with modulation. (*4FSK, C4FM or other digital modulation form).
- 2) Path loss for the measurement included.
- 3) Select the Occupied Bandwidth measurement for 99% and 26dB Emissions Bandwidth Measurement.
- 4) Key in the Fc and Resolution Bandwidth.
- 5) Transmit radio record the occupied Bandwidth frequencies.
- 6) Preset the spectrum analyzer for band edge measurement.
- 7) Key in the lowest and highest channels frequency, span is 60 kHz and Resolution Bandwidth is at least 1% of Emission Bandwidth.
- 8) Save the screen shot.

*Note:

- For Digital Modulation, 12.5 kHz Data F1D & FXD would be the same. Therefore only measurements with F1D modulation shown below.
- For Digital Modulation, 12.5 kHz Data F1E & FXE would be the same. Therefore only measurements with F1E modulation shown below.

6.7.4. Test Result (Digital)

Not Applicable

6.7.5. Test Limit

The power of any emission outside of the authorized operating frequency ranges must be attenuated below the transmitting power (P) by a factor of at least $43 + 10 \log(P)$ dB.

6.8. Transient Frequency Behavior

6.8.1. Test Setup

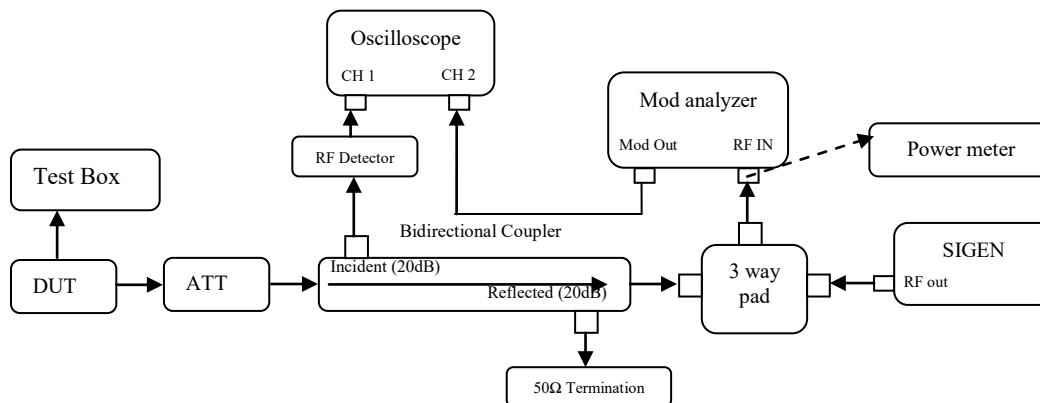

- 1) Connect the setup as figure above.
- 2) Path loss for the measurement included.
- 3) Set on Siggen with the assigned center frequency, internal 1 kHz FM tone.
FM Deviation: Analog 25kHz Channel Spacing = 25 kHz
Analog 12.5 kHz Channel Spacing = 12.5 kHz
C4FM = 12.5 kHz
- 4) Turn on 50 kHz high pass filter and 15 kHz low pass filter on modulation analyzer.
- 5) Supply sufficient attenuation ATT to provide the output power of $\leq -11\text{dBm}$ into power meter when DUT is keying up.
- 6) Note the power level on power meter and dekey the DUT.
- 7) Adjust the amplitude of the signal generator to the level power meter, maintained the amplitude throughout the rest of the measurement.
- 8) Connect the output to modulation analyzer.
- 9) Reduce 30dB attenuation and transmit the radio to get the trigger line.
- 10) Capture the screen shot for key-up (rising edge) and de-key (falling edge) mode.

6.8.2. Test Result

Not Applicable

6.8.3. Test Limit

Transmitters designed to operate in the 150-174 MHz and 421-512 MHz frequency bands must maintain transient frequencies within the maximum frequency difference limits during the time intervals indicated:

Time intervals ^{1 2}	Maximum frequency difference ³	All equipment	
		150 to 174 MHz	421 to 512 MHz
Transient Frequency Behavior for Equipment Designed to Operate on 25 kHz Channels			
t ₁ ⁴	±25.0 kHz	5.0 ms	10.0 ms
t ₂	±12.5 kHz	20.0 ms	25.0 ms
t ₃ ⁴	±25.0 kHz	5.0 ms	10.0 ms
Transient Frequency Behavior for Equipment Designed to Operate on 12.5 kHz Channels			
t ₁ ⁴	±12.5 kHz	5.0 ms	10.0 ms
t ₂	±6.25 kHz	20.0 ms	25.0 ms
t ₃ ⁴	±12.5 kHz	5.0 ms	10.0 ms
Transient Frequency Behavior for Equipment Designed to Operate on 6.25 kHz Channels			
t ₁ ⁴	±6.25 kHz	5.0 ms	10.0 ms
t ₂	±3.125 kHz	20.0 ms	25.0 ms
t ₃ ⁴	±6.25 kHz	5.0 ms	10.0 ms

¹ _{on} is the instant when a 1 kHz test signal is completely suppressed, including any capture time due to phasing.

t₁ is the time period immediately following t_{on}.

t₂ is the time period immediately following t₁.

t₃ is the time period from the instant when the transmitter is turned off until t_{off}.

t_{off} is the instant when the 1 kHz test signal starts to rise.

² During the time from the end of t₂ to the beginning of t₃, the frequency difference must not exceed the limits specified in §90.213.

³ Difference between the actual transmitter frequency and the assigned transmitter frequency.

⁴ If the transmitter carrier output power rating is 6 watts or less, the frequency difference during this time period may exceed the maximum frequency difference for this time period.

6.9. Adjacent Channel Power

6.9.1. Test Setup (Analog)

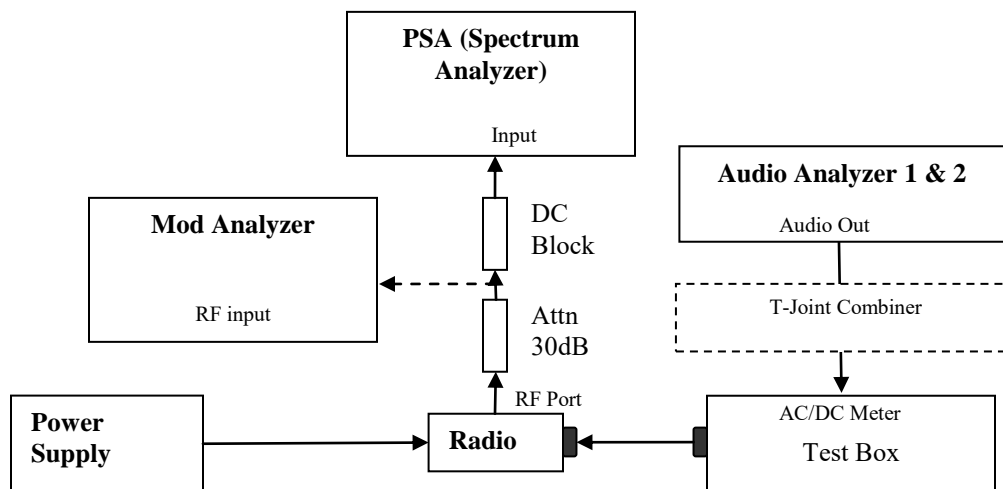

- 1) The DUT transmitter output port was connected to modulation analyzer.
- 2) Transmit the radio and turn on 1st audio analyzer with audio frequency 650Hz, 50% rated deviation, and record the amplitude value as AmpT1.
- 3) Turn off Audio analyzer 1 and turn on audio analyzer 2, set the audio frequency to 2.2 kHz and 50% deviation. Record the amplitude as AmpT2.
- 4) Turn both audio analyzers ON and up 10dB amplitude level.
- 5) Connect the output to PSA and set to assigned center frequency.
- 6) Set Span, Resolution Bandwidth and Video Bandwidth per rules part.
- 7) Transmit the radio and record the Adjacent Channel Power value in dBc.

6.9.2. Test Result

Mode	Analog			
Frequency, MHz	769.0875 MHz			
Channel Spacing, kHz	12.5			
Offset (kHz)	Meas BW (kHz)	Lower	Upper	Spec (dB)
9.375	6.25	-72.407	-72.077	-40
15.625	6.25	-76.066	-77.199	-60
21.875	6.25	-77.913	-78.514	-60
37.500	25	-73.421	-73.426	-65
62.500	25	-75.341	-75.120	-65
87.500	25	-77.640	-77.835	-65
150.000	100	-75.651	-75.734	-65
250.000	100	-80.826	-80.760	-65
350.000	100	-83.419	-83.545	-65
400k	30	-89.626	-89.160	-75
12M	30	-91.589	-90.969	-75

Mode	Analog			
Frequency, MHz	774.8875 MHz			
Channel Spacing, kHz	12.5			
Offset (kHz)	Meas BW (kHz)	Lower	Upper	Spec (dB)
9.375	6.25	-72.385	-72.383	-40
15.625	6.25	-76.352	-76.278	-60
21.875	6.25	-76.872	-77.467	-60
37.500	25	-73.069	-73.371	-65
62.500	25	-75.204	-75.319	-65
87.500	25	-77.619	-77.805	-65
150.000	100	-75.718	-75.774	-65
250.000	100	-80.686	-80.778	-65
350.000	100	-83.533	-83.778	-65
400k	30	-89.379	-89.528	-75
12M	30	-91.170	-91.208	-75

Mode	Analog			
Frequency, MHz	799.0875 MHz			
Channel Spacing, kHz	12.5			
Offset (kHz)	Meas BW (kHz)	Lower	Upper	Spec (dB)
9.375	6.25	-71.832	-71.529	-40
15.625	6.25	-76.467	-74.922	-60
21.875	6.25	-76.151	-77.253	-60
37.500	25	-73.036	-73.074	-65
62.500	25	-75.095	-75.200	-65
87.500	25	-77.692	-77.529	-65
150.000	100	-75.858	-75.973	-65
250.000	100	-80.752	-80.938	-65
350.000	100	-83.578	-83.591	-65
400k	30	-89.042	-89.418	-75
12M	30	-90.542	-90.447	-75

Mode	Analog			
Frequency, MHz	804.9125 MHz			
Channel Spacing, kHz	12.5			
Offset (kHz)	Meas BW (kHz)	Lower	Upper	Spec (dB)
9.375	6.25	-71.717	-71.935	-40
15.625	6.25	-75.843	-75.799	-60
21.875	6.25	-77.542	-77.870	-60
37.500	25	-72.952	-72.934	-65
62.500	25	-75.309	-75.110	-65
87.500	25	-77.486	-77.638	-65
150.000	100	-75.808	-75.886	-65
250.000	100	-80.795	-80.760	-65
350.000	100	-83.522	-83.551	-65
400k	30	-89.577	-89.370	-75
12M	30	-90.766	-90.912	-75

6.9.3. Test Setup (Digital)

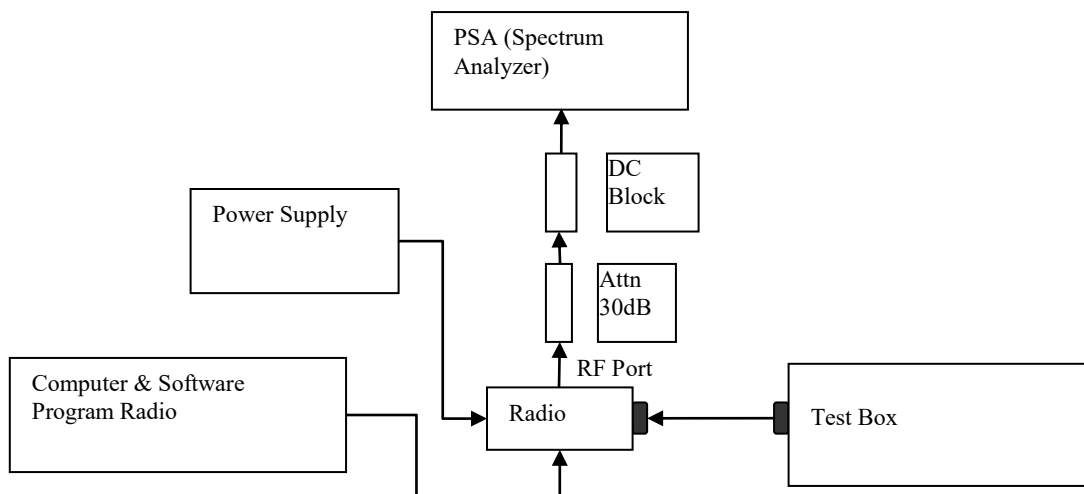

- 1) Program and set radio to operate in desire test frequency and digital mode with modulation. (4FSK, C4FM or other digital modulation form).
- 2) Prepare setup as per picture.
- 3) Turn on the ACP Measurement – Press Measure, ACP.
- 4) Set Span, Resolution Bandwidth and Video Bandwidth as per rules part.
- 5) Transmit the radio and record the Adjacent Channel Power value in dBc.

6.9.4. Test Result

Mode	Digital Data			
Frequency, MHz	769.0875 MHz			
Channel Spacing, kHz	12.5			
Offset (kHz)	Meas BW (kHz)	Lower	Upper	Spec (dB)
9.375	6.25	-40.330	-40.383	-40
15.625	6.25	-75.701	-76.088	-60
21.875	6.25	-77.174	-76.757	-60
37.500	25	-73.061	-73.307	-65
62.500	25	-75.252	-75.228	-65
87.500	25	-77.928	-77.678	-65
150.000	100	-75.666	-75.797	-65
250.000	100	-80.745	-80.983	-65
350.000	100	-83.660	-83.600	-65
400k	30	-89.355	-89.628	-75
12M	30	-91.283	-91.606	-75

Mode	Digital Data			
Frequency, MHz	774.8875 MHz			
Channel Spacing, kHz	12.5			
Offset (kHz)	Meas BW (kHz)	Lower	Upper	Spec (dB)
9.375	6.25	-40.410	-41.271	-40
15.625	6.25	-75.856	-75.588	-60
21.875	6.25	-76.685	-76.905	-60
37.500	25	-73.264	-73.169	-65
62.500	25	-75.238	-75.169	-65
87.500	25	-77.508	-77.812	-65
150.000	100	-75.691	-75.786	-65
250.000	100	-80.866	-80.813	-65
350.000	100	-83.477	-83.495	-65
400k	30	-89.240	-89.818	-75
12M	30	-91.134	-91.283	-75

Mode	Digital Data			
Frequency, MHz	799.0875 MHz			
Channel Spacing, kHz	12.5			
Offset (kHz)	Meas BW (kHz)	Lower	Upper	Spec (dB)
9.375	6.25	-40.083	-40.509	-40
15.625	6.25	-75.988	-75.195	-60
21.875	6.25	-76.886	-76.805	-60
37.500	25	-72.887	-72.860	-65
62.500	25	-75.088	-75.415	-65
87.500	25	-77.922	-77.613	-65
150.000	100	-75.943	-75.868	-65
250.000	100	-80.740	-80.931	-65
350.000	100	-83.647	-83.729	-65
400k	30	-89.973	-89.239	-75
12M	30	-90.958	-90.877	-75

Mode	Digital Data			
Frequency, MHz	804.9125 MHz			
Channel Spacing, kHz	12.5			
Offset (kHz)	Meas BW (kHz)	Lower	Upper	Spec (dB)
9.375	6.25	-41.177	-40.870	-40
15.625	6.25	-75.193	-75.186	-60
21.875	6.25	-76.412	-76.493	-60
37.500	25	-72.825	-72.962	-65
62.500	25	-74.906	-74.795	-65
87.500	25	-77.549	-77.371	-65
150.000	100	-75.596	-75.677	-65
250.000	100	-80.806	-80.826	-65
350.000	100	-83.514	-83.524	-65
400k	30	-89.231	-89.274	-75
12M	30	-90.953	-90.520	-75

Mode	Digital Voice			
Frequency, MHz	769.0875 MHz			
Channel Spacing, kHz	12.5			
Offset (kHz)	Meas BW (kHz)	Lower	Upper	Spec (dB)
9.375	6.25	-46.220	-48.580	-40
15.625	6.25	-75.000	-75.890	-60
21.875	6.25	-77.190	-78.140	-60
37.500	25	-73.530	-73.820	-65
62.500	25	-74.890	-74.500	-65
87.500	25	-77.720	-77.560	-65
150.000	100	-75.230	-75.250	-65
250.000	100	-80.760	-81.170	-65
350.000	100	-83.540	-83.400	-65
400k	30	-89.140	-89.390	-75
12M	30	-92.590	-92.670	-75

Mode	Digital Voice			
Frequency, MHz	774.8875 MHz			
Channel Spacing, kHz	12.5			
Offset (kHz)	Meas BW (kHz)	Lower	Upper	Spec (dB)
9.375	6.25	-50.360	-52.720	-40
15.625	6.25	-75.030	-75.280	-60
21.875	6.25	-77.490	-77.210	-60
37.500	25	-73.120	-72.830	-65
62.500	25	-74.550	-74.410	-65
87.500	25	-77.970	-77.780	-65
150.000	100	-75.220	-75.270	-65
250.000	100	-80.950	-80.820	-65
350.000	100	-83.530	-83.580	-65
400k	30	-89.590	-89.440	-75
12M	30	-92.870	-92.230	-75

Mode	Digital Voice			
Frequency, MHz	799.0875 MHz			
Channel Spacing, kHz	12.5			
Offset (kHz)	Meas BW (kHz)	Lower	Upper	Spec (dB)
9.375	6.25	-46.490	-46.990	-40
15.625	6.25	-74.960	-74.330	-60
21.875	6.25	-74.850	-75.770	-60
37.500	25	-72.960	-73.090	-65
62.500	25	-74.050	-73.990	-65
87.500	25	-78.680	-78.580	-65
150.000	100	-75.040	-75.230	-65
250.000	100	-80.360	-80.210	-65
350.000	100	-83.460	-83.680	-65
400k	30	-88.990	-89.430	-75
12M	30	-92.760	-92.340	-75

Mode	Digital Voice			
Frequency, MHz	804.9125 MHz			
Channel Spacing, kHz	12.5			
Offset (kHz)	Meas BW (kHz)	Lower	Upper	Spec (dB)
9.375	6.25	-51.320	-50.240	-40
15.625	6.25	-75.620	-74.110	-60
21.875	6.25	-77.530	-77.470	-60
37.500	25	-72.740	-72.500	-65
62.500	25	-74.520	-74.260	-65
87.500	25	-77.780	-77.840	-65
150.000	100	-74.550	-74.230	-65
250.000	100	-82.050	-82.210	-65
350.000	100	-83.460	-83.840	-65
400k	30	-89.100	-88.910	-75
12M	30	-92.640	-92.180	-75

Mode	Digital Voice Encyption			
Frequency, MHz	769.0875 MHz			
Channel Spacing, kHz	12.5			
Offset (kHz)	Meas BW (kHz)	Lower	Upper	Spec (dB)
9.375	6.25	-45.280	-44.850	-40
15.625	6.25	-75.590	-75.240	-60
21.875	6.25	-76.980	-76.580	-60
37.500	25	-72.000	-72.190	-65
62.500	25	-75.180	-75.360	-65
87.500	25	-77.580	-77.350	-65
150.000	100	-75.590	-75.760	-65
250.000	100	-80.640	-80.840	-65
350.000	100	-82.970	-82.870	-65
400k	30	-88.980	-89.120	-75
12M	30	-93.110	-93.050	-75

Mode	Digital Voice Encyption			
Frequency, MHz	774.8875 MHz			
Channel Spacing, kHz	12.5			
Offset (kHz)	Meas BW (kHz)	Lower	Upper	Spec (dB)
9.375	6.25	-41.140	-40.590	-40
15.625	6.25	-73.530	-73.320	-60
21.875	6.25	-77.070	-77.690	-60
37.500	25	-72.480	-72.120	-65
62.500	25	-74.900	-74.350	-65
87.500	25	-77.490	-77.330	-65
150.000	100	-75.670	-75.950	-65
250.000	100	-80.340	-80.560	-65
350.000	100	-83.280	-83.420	-65
400k	30	-89.640	-89.530	-75
12M	30	-92.890	-93.110	-75

Mode	Digital Voice Encyption			
Frequency, MHz	799.0875 MHz			
Channel Spacing, kHz	12.5			
Offset (kHz)	Meas BW (kHz)	Lower	Upper	Spec (dB)
9.375	6.25	-45.750	-44.930	-40
15.625	6.25	-74.800	-74.640	-60
21.875	6.25	-76.520	-76.780	-60
37.500	25	-73.470	-73.460	-65
62.500	25	-74.680	-74.910	-65
87.500	25	-77.350	-77.490	-65
150.000	100	-75.970	-75.080	-65
250.000	100	-81.490	-81.700	-65
350.000	100	-83.120	-83.550	-65
400k	30	-89.310	-89.520	-75
12M	30	-92.970	-93.050	-75

Mode	Digital Voice Encyption			
Frequency, MHz	804.9125 MHz			
Channel Spacing, kHz	12.5			
Offset (kHz)	Meas BW (kHz)	Lower	Upper	Spec (dB)
9.375	6.25	-41.010	-40.250	-40
15.625	6.25	-74.680	-74.540	-60
21.875	6.25	-76.240	-76.530	-60
37.500	25	-73.450	-73.180	-65
62.500	25	-74.940	-75.000	-65
87.500	25	-77.250	-77.530	-65
150.000	100	-75.860	-75.630	-65
250.000	100	-81.230	-81.820	-65
350.000	100	-82.560	-82.900	-65
400k	30	-88.300	-88.270	-75
12M	30	-92.880	-92.150	-75

Mode	Phase II			
Frequency, MHz	769.0875 MHz			
Channel Spacing, kHz	12.5			
Offset (kHz)	Meas BW (kHz)	Lower	Upper	Spec (dB)
9.375	6.25	-42.408	-42.192	-40
15.625	6.25	-76.933	-75.989	-60
21.875	6.25	-77.185	-78.127	-60
37.500	25	-76.244	-76.407	-65
62.500	25	-77.853	-78.042	-65
87.500	25	-80.768	-80.997	-65
150.000	100	-78.237	-78.522	-65
250.000	100	-83.161	-83.122	-65
350.000	100	-85.083	-85.102	-65
400k	30	-91.596	-90.789	-75
12M	30	-91.053	-90.901	-75

Mode	Phase II			
Frequency, MHz	774.8875 MHz			
Channel Spacing, kHz	12.5			
Offset (kHz)	Meas BW (kHz)	Lower	Upper	Spec (dB)
9.375	6.25	-41.470	-42.450	-40
15.625	6.25	-75.740	-76.225	-60
21.875	6.25	-76.882	-77.131	-60
37.500	25	-76.059	-76.280	-65
62.500	25	-78.166	-78.558	-65
87.500	25	-80.287	-80.753	-65
150.000	100	-78.484	-78.349	-65
250.000	100	-82.958	-82.958	-65
350.000	100	-85.018	-85.020	-65
400k	30	-90.711	-91.013	-75
12M	30	-91.158	-91.646	-75

Mode	Phase II			
Frequency, MHz	799.0875 MHz			
Channel Spacing, kHz	12.5			
Offset (kHz)	Meas BW (kHz)	Lower	Upper	Spec (dB)
9.375	6.25	-41.563	-43.605	-40
15.625	6.25	-76.390	-77.510	-60
21.875	6.25	-95.165	-96.593	-60
37.500	25	-76.058	-76.136	-65
62.500	25	-78.038	-78.238	-65
87.500	25	-80.911	-80.948	-65
150.000	100	-78.782	-79.015	-65
250.000	100	-83.017	-82.892	-65
350.000	100	-85.157	-85.079	-65
400k	30	-90.805	-90.054	-75
12M	30	-90.988	-90.554	-75

Mode	Phase II			
Frequency, MHz	804.9125 MHz			
Channel Spacing, kHz	12.5			
Offset (kHz)	Meas BW (kHz)	Lower	Upper	Spec (dB)
9.375	6.25	-42.980	-44.040	-40
15.625	6.25	-75.910	-77.121	-60
21.875	6.25	-86.085	-87.756	-60
37.500	25	-75.975	-76.179	-65
62.500	25	-78.154	-78.120	-65
87.500	25	-80.808	-80.460	-65
150.000	100	-78.914	-78.498	-65
250.000	100	-83.008	-83.014	-65
350.000	100	-85.102	-84.938	-65
400k	30	-90.741	-90.961	-75
12M	30	-90.751	-90.790	-75

6.9.5. Test Limit

12.5 kHz MOBILE TRANSMITTER ACP REQUIREMENTS

Offset from center frequency (kHz)	Measurement bandwidth (kHz)	Maximum ACP relative (dBc)
9.375	6.25	-40
15.625	6.25	-60
21.875	6.25	-60
37.50	25.00	-60
62.50	25.00	-65
87.50	25.00	-65
150.00	100	-65
250.00	100	-65
350.00	100	-65
>400 to 12 MHz	30 (s)	-75
12 MHz to paired receive band	30 (s)	-75
In the paired receive band	30 (s)	-100

25 kHz MOBILE TRANSMITTER ACP REQUIREMENTS

Offset from center frequency (kHz)	Measurement bandwidth (kHz)	Maximum ACP relative (dBc)
15.625	6.25	-40
21.875	6.25	-60
37.50	25	-60
62.50	25	-65
87.50	25	-65
150.00	100	-65
250.00	100	-65
350.00	100	-65
>400 kHz to 12 MHz	30 (s)	-75
12 MHz to paired receive band	30 (s)	-75
In the paired receive band	30 (s)	-100

12.5 kHz BASE TRANSMITTER ACP REQUIREMENTS

Offset from center frequency (kHz)	Measurement bandwidth (kHz)	Maximum ACP (dBc)
9.375	6.25	-40
15.625	6.25	-60
21.875	6.25	-60
37.5	25	-60
62.5	25	-65
87.5	25	-65
150	100	-65
250	100	-65
350.00	100	-65
>400 kHz to 12 MHz	30 (s)	-80
12 MHz to paired receive band	30 (s)	-80
In the paired receive band	30 (s)	1-85

25 kHz BASE TRANSMITTER ACP REQUIREMENTS

Offset from center frequency (kHz)	Measurement bandwidth (kHz)	Maximum ACP (dBc)
15.625	6.25	-40
21.875	6.25	-60
37.5	25	-60
62.5	25	-65
87.5	25	-65
150	100	-65
250	100	-65
350	100.00	-65
>400 kHz to 12 MHz	30 (s)	-80
12 MHz to paired receive band	30 (s)	-80
In the paired receive band	30 (s)	1-85

6.10. Conducted Spurious Emission

6.10.1. Test Setup

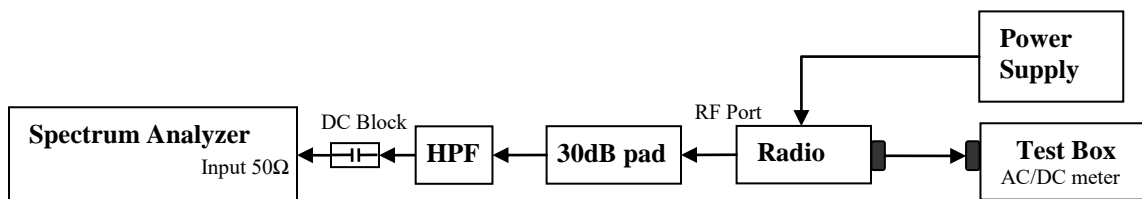

- 1) The DUT transmitter output port was connected to Spectrum Analyzer with above setup.
- 2) Program and set radio to operate in desire test frequency and mode. (Analog / digital modulation form).
- 3) Path loss for the measurement included.
- 4) Set the PSA Resolution Bandwidth as per rules part.
- 5) Set the Ref offset from the pathloss offset calibration file.
- 6) Adjust the center frequency of the spectrum analyzer for incremental coverage of the range from:
 - a. 9 KHz to $F_c - \text{Test Bandwidth}$
 - b. $F_c + \text{Test Bandwidth}$ to $2F_c - 5\text{MHz}$.
- 7) Key up the DUT, Peak Search the highest Spur and record the levels of spurious emissions
- 8) Dekey the DUT.
- 9) Turn On High Pass Filter path and Key up the DUT.
- 10) Adjust the PSA Freq for incremental coverage of range from $2F_c$ to $10F_c$
- 11) Key up the DUT and record the highest spur levels of spurious emissions.

6.10.2. Test Result (Analog)

Analog: 762.0125 MHz, 12.5kHz Channel Spacing, Max Power (Not For FCC Review)

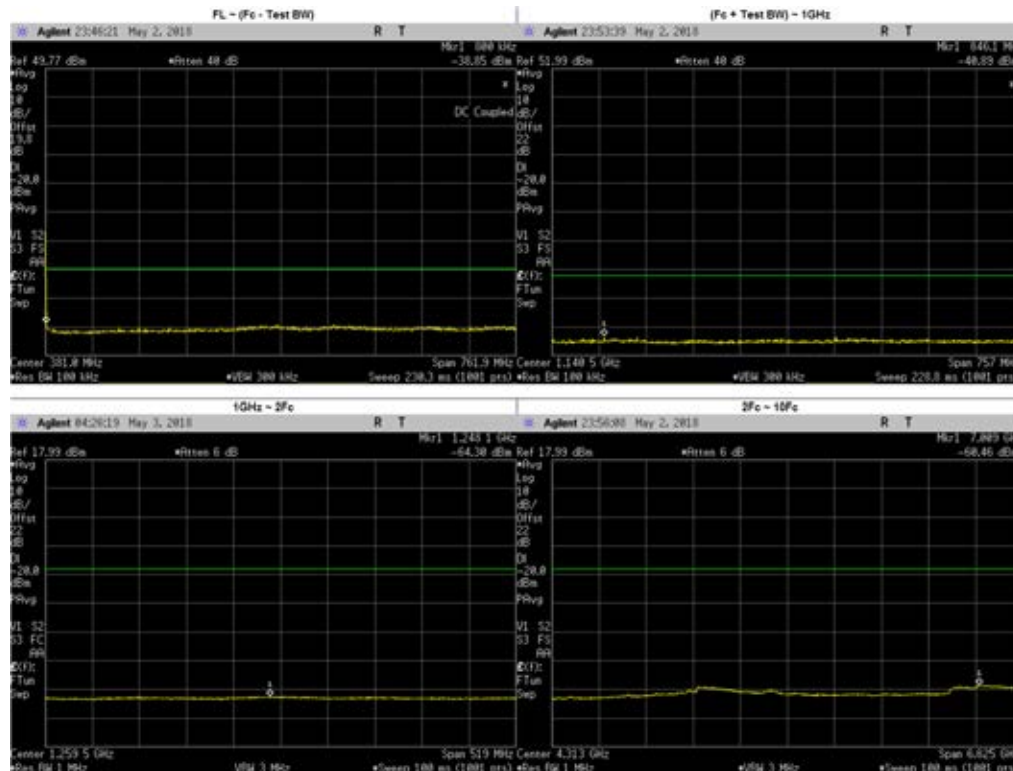

Frequency Range	Highest Spur Frequency (MHz)	Spurious Level (dBm)	Failing Limit (dBm)	Results
FL ~ (Fc - Test BW)	376.4113	-38.03	-20	PASS
(Fc + Test BW) ~ 1GHz	846.1000	-40.89	-20	PASS
1GHz ~ 2Fc	1248.1000	-64.30	-20	PASS
2Fc ~ 10Fc	7009.0000	-60.46	-20	PASS
	1524.0250	-64.96	-20	PASS
	2286.0370	-64.37	-20	PASS
	3048.0500	-61.13	-20	PASS
	3810.0620	-62.92	-20	PASS
	4572.0750	-63.70	-20	PASS
	5334.0870	-63.81	-20	PASS
	6096.1000	-63.69	-20	PASS
	6858.1130	-61.44	-20	PASS
	7620.1250	-61.70	-20	PASS

Analog: 762.0125 MHz, 12.5kHz Channel Spacing, Low Power
(Not For FCC Review)

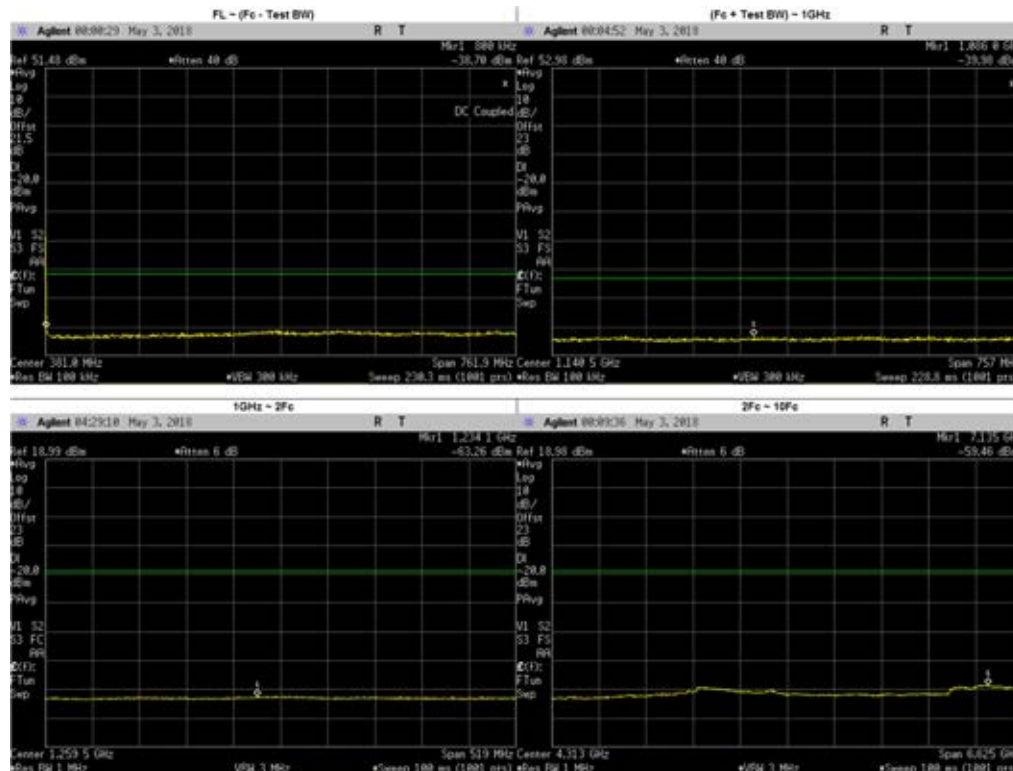

Frequency Range	Highest Spur Frequency (MHz)	Spurious Level (dBm)	Failing Limit (dBm)	Results
FL ~ (Fc - Test BW)	374.1254	-39.53	-20	PASS
(Fc + Test BW) ~ 1GHz	1086.0000	-39.98	-20	PASS
1GHz ~ 2Fc	1.234.1	-63.26	-20	PASS
2Fc ~ 10Fc	7135.0000	-59.46	-20	PASS
	1524.0250	-64.15	-20	PASS
	2286.0370	-63.39	-20	PASS
	3048.0500	-60.24	-20	PASS
	3810.0620	-61.93	-20	PASS
	4572.0750	-62.84	-20	PASS
	5334.0870	-62.76	-20	PASS
	6096.1000	-62.69	-20	PASS
	6858.1130	-60.52	-20	PASS
7620.1250	-60.84	-20	PASS	

Analog: 764.0125 MHz, 12.5kHz Channel Spacing, Max Power
(Not For FCC Review)

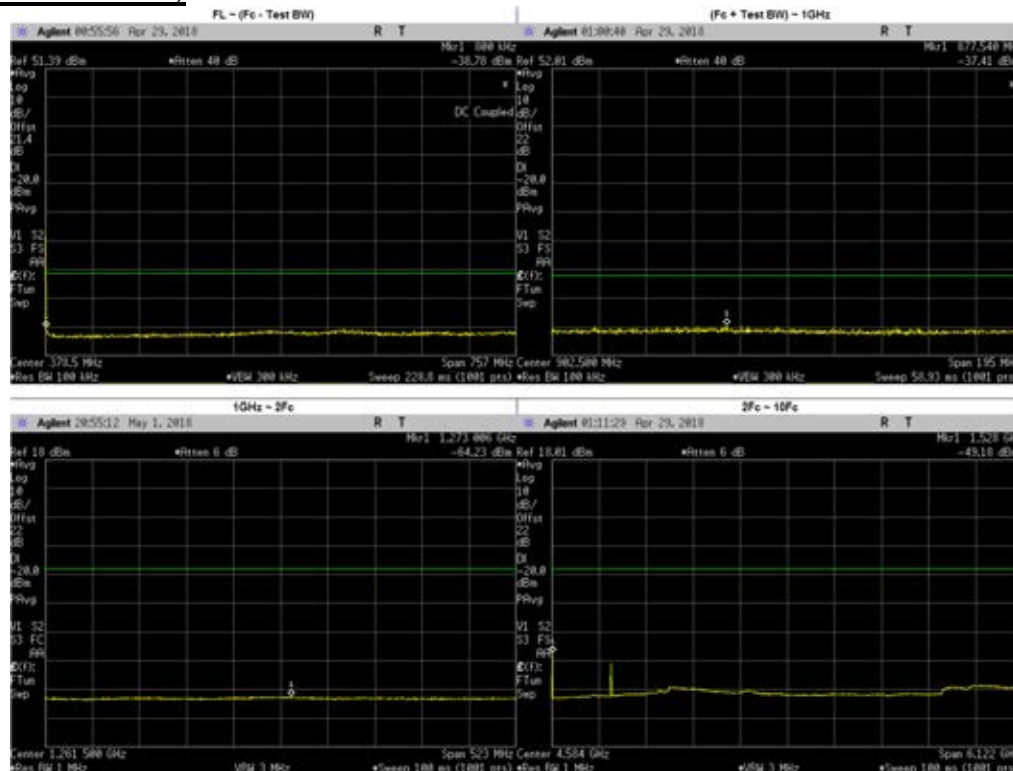

Frequency Range	Highest Spur Frequency (MHz)	Spurious Level (dBm)	Failing Limit (dBm)	Results
FL ~ (Fc - Test BW)	481.4553	-39.58	-20	PASS
(Fc + Test BW) ~ 1GHz	877.5400	-37.41	-20	PASS
1GHz ~ 2Fc	1273.0060	-64.23	-20	PASS
2Fc ~ 10Fc	1528.0250	-49.18	-20	PASS
	2292.0370	-56.25	-20	PASS
	3056.0500	-61.20	-20	PASS
	3820.0620	-62.91	-20	PASS
	4584.0750	-63.89	-20	PASS
	5348.0870	-63.70	-20	PASS
	6112.1000	-63.50	-20	PASS
	6876.1130	-61.67	-20	PASS
	7640.1250	-61.61	-20	PASS

Analog: 764.0125 MHz, 12.5kHz Channel Spacing, Low Power
(Not For FCC Review)

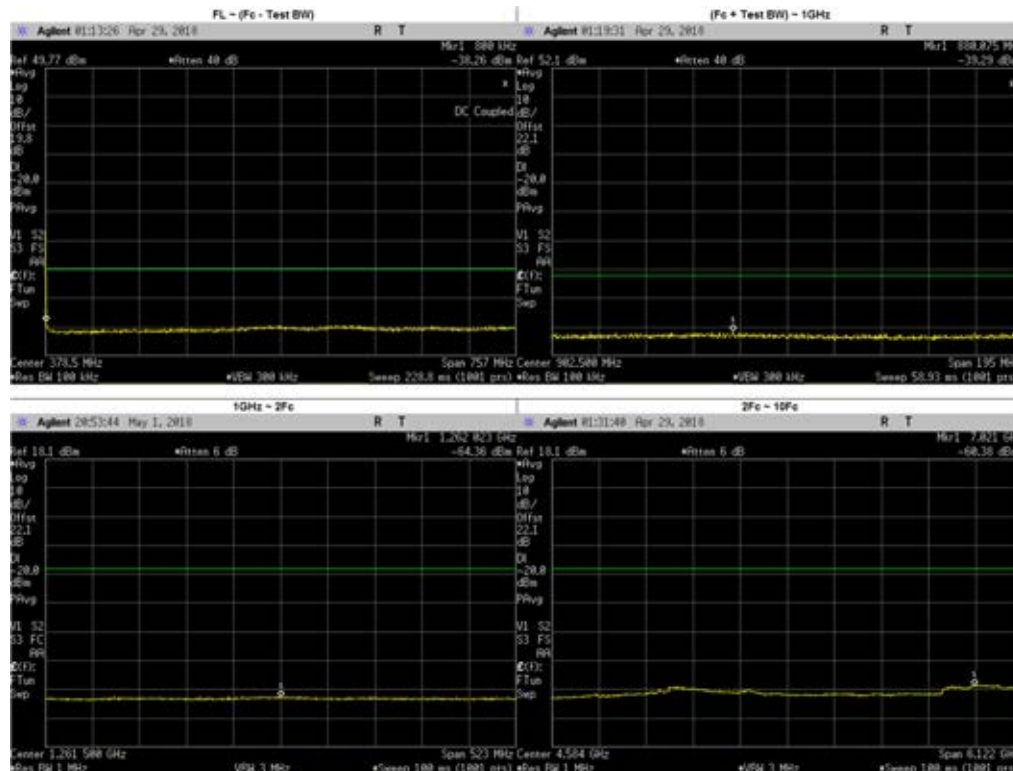

Frequency Range	Highest Spur Frequency (MHz)	Spurious Level (dBm)	Failing Limit (dBm)	Results
FL ~ (Fc - Test BW)	492.0532	-38.11	-20	PASS
(Fc + Test BW) ~ 1GHz	880.0750	-39.61	-20	PASS
1GHz ~ 2Fc	1262.0230	-64.36	-20	PASS
2Fc ~ 10Fc	7020.6710	-60.38	-20	PASS
	1528.0250	-64.55	-20	PASS
	2292.0370	-64.33	-20	PASS
	3056.0500	-61.04	-20	PASS
	3820.0620	-62.70	-20	PASS
	4584.0750	-63.67	-20	PASS
	5348.0870	-63.60	-20	PASS
	6112.1000	-63.52	-20	PASS
	6876.1130	-61.49	-20	PASS
7640.1250	-61.30	-20	PASS	

Analog: 769.0125 MHz, 12.5kHz Channel Spacing, Max Power
Part 90

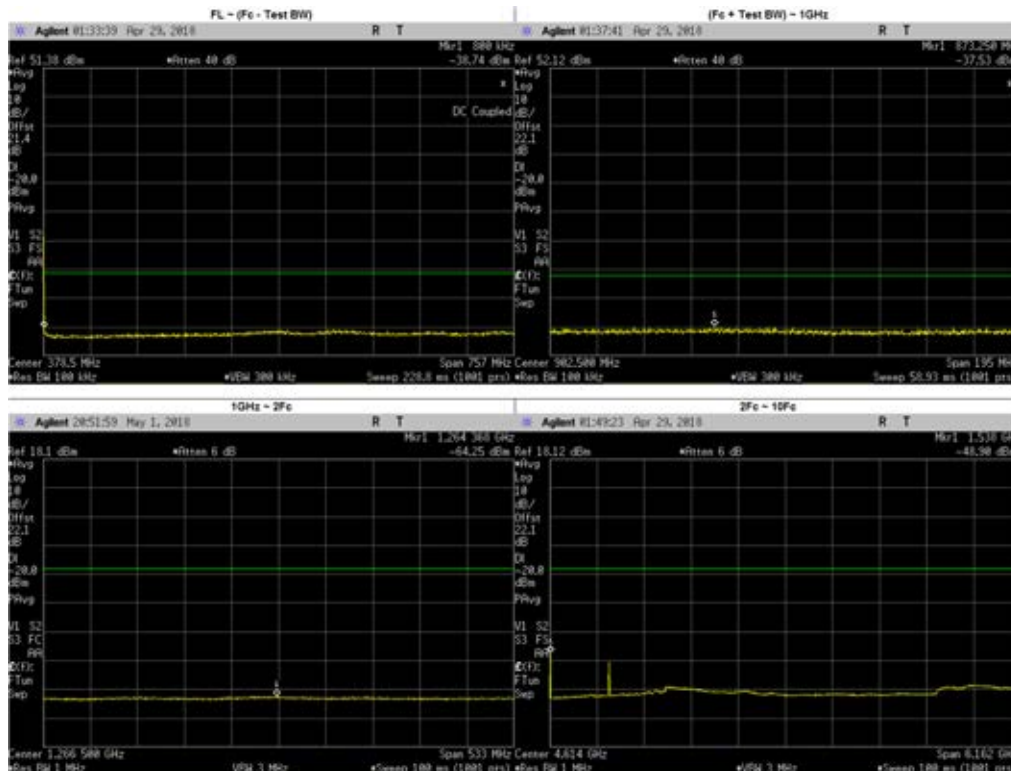

Frequency Range	Highest Spur Frequency (MHz)	Spurious Level (dBm)	Failing Limit (dBm)	Results
FL ~ (Fc - Test BW)	456.4746	-39.69	-20	PASS
(Fc + Test BW) ~ 1GHz	873.2500	-37.87	-20	PASS
1GHz ~ 2Fc	1264.3680	-64.25	-20	PASS
2Fc ~ 10Fc	1538.0250	-48.90	-20	PASS
	2307.0370	-55.72	-20	PASS
	3076.0500	-60.98	-20	PASS
	3845.0620	-63.01	-20	PASS
	4614.0750	-64.03	-20	PASS
	5383.0870	-63.45	-20	PASS
	6152.1000	-63.29	-20	PASS
	6921.1130	-61.44	-20	PASS
	7690.1250	-60.92	-20	PASS

**Analog: 769.0875 MHz, 12.5kHz Channel Spacing, Max Power
 FCC Part 90, RSS 119**

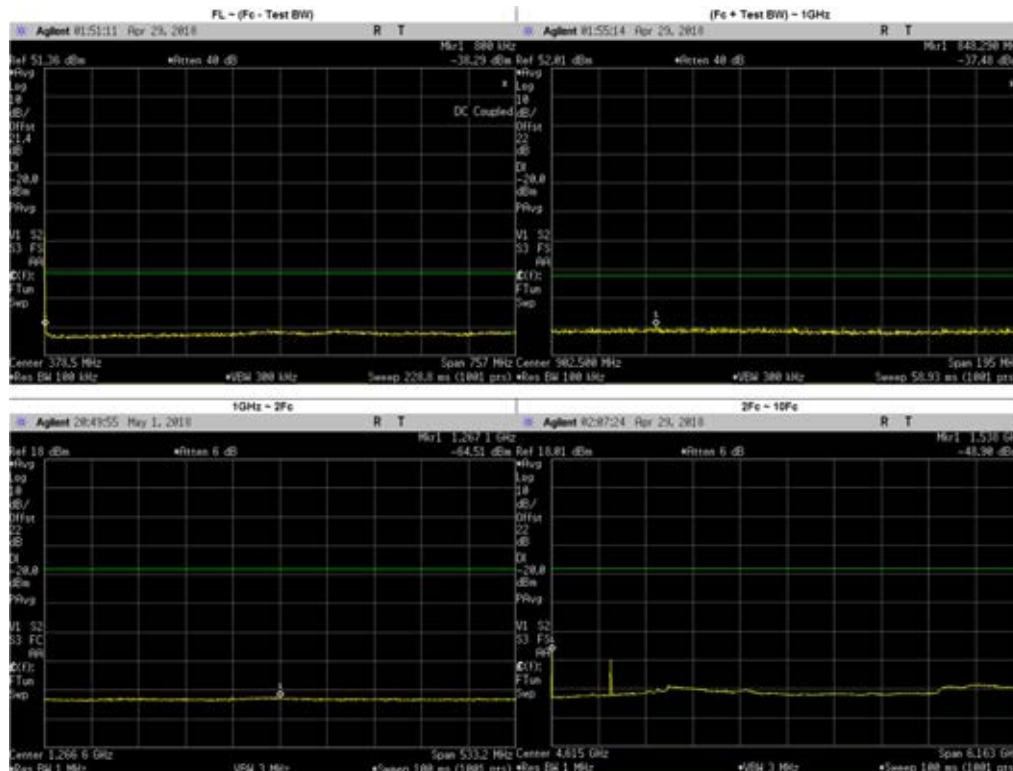

Frequency Range	Highest Spur Frequency (MHz)	Spurious Level (dBm)	Failing Limit (dBm)	Results
FL ~ (Fc - Test BW)	471.6144	-39.67	-20	PASS
(Fc + Test BW) ~ 1GHz	848.2900	-37.48	-20	PASS
1GHz ~ 2Fc	1267.1000	-64.51	-20	PASS
2Fc ~ 10Fc	1538.1750	-48.90	-20	PASS
	2307.2620	-55.21	-20	PASS
	3076.3500	-61.20	-20	PASS
	3845.4370	-62.92	-20	PASS
	4614.5250	-63.91	-20	PASS
	5383.6130	-63.70	-20	PASS
	6152.7000	-63.58	-20	PASS
	6921.7880	-61.65	-20	PASS
	7690.8750	-61.00	-20	PASS

**Analog: 769.0875 MHz, 12.5kHz Channel Spacing, Low Power
 FCC Part 90, RSS 119**

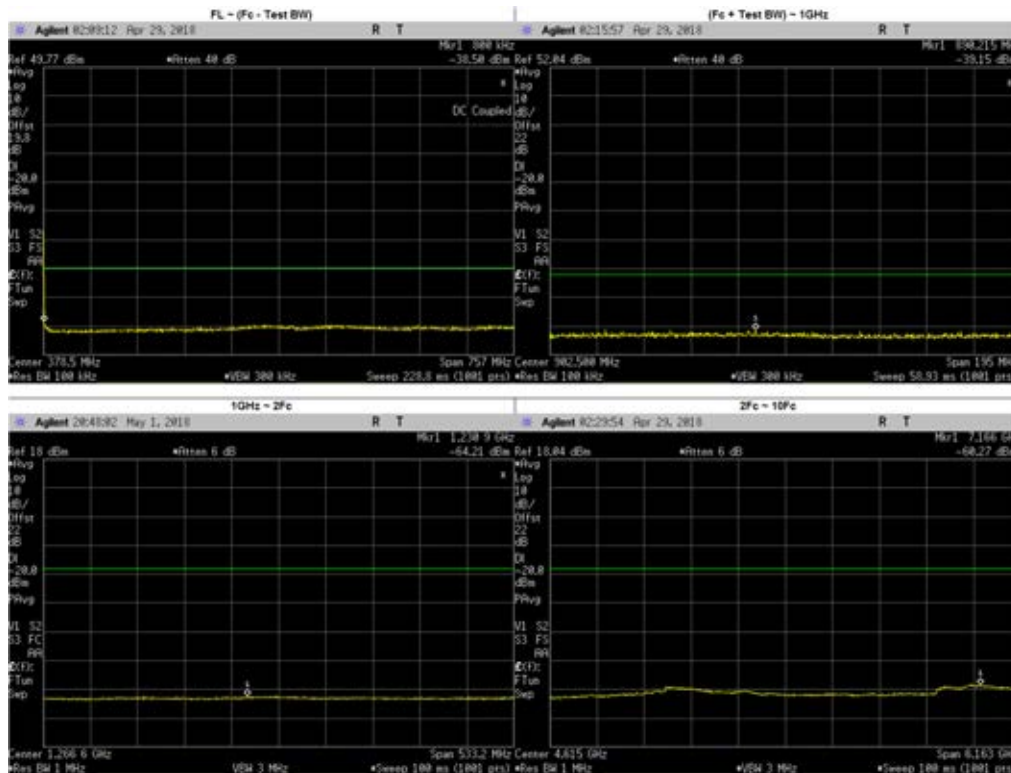

Frequency Range	Highest Spur Frequency (MHz)	Spurious Level (dBm)	Failing Limit (dBm)	Results
FL ~ (Fc - Test BW)	355.7948	-38.08	-20	PASS
(Fc + Test BW) ~ 1GHz	890.2150	-39.15	-20	PASS
1GHz ~ 2Fc	1230.9000	-64.21	-20	PASS
2Fc ~ 10Fc	7165.8830	-60.27	-20	PASS
	1538.1750	-64.63	-20	PASS
	2307.2620	-64.18	-20	PASS
	3076.3500	-61.12	-20	PASS
	3845.4370	-63.07	-20	PASS
	4614.5250	-63.95	-20	PASS
	5383.6130	-63.50	-20	PASS
	6152.7000	-63.37	-20	PASS
	6921.7880	-61.44	-20	PASS
7690.8750	-60.97	-20	PASS	

**Analog: 774.8875 MHz, 12.5kHz Channel Spacing, Max Power
 FCC Part 90, RSS 119**

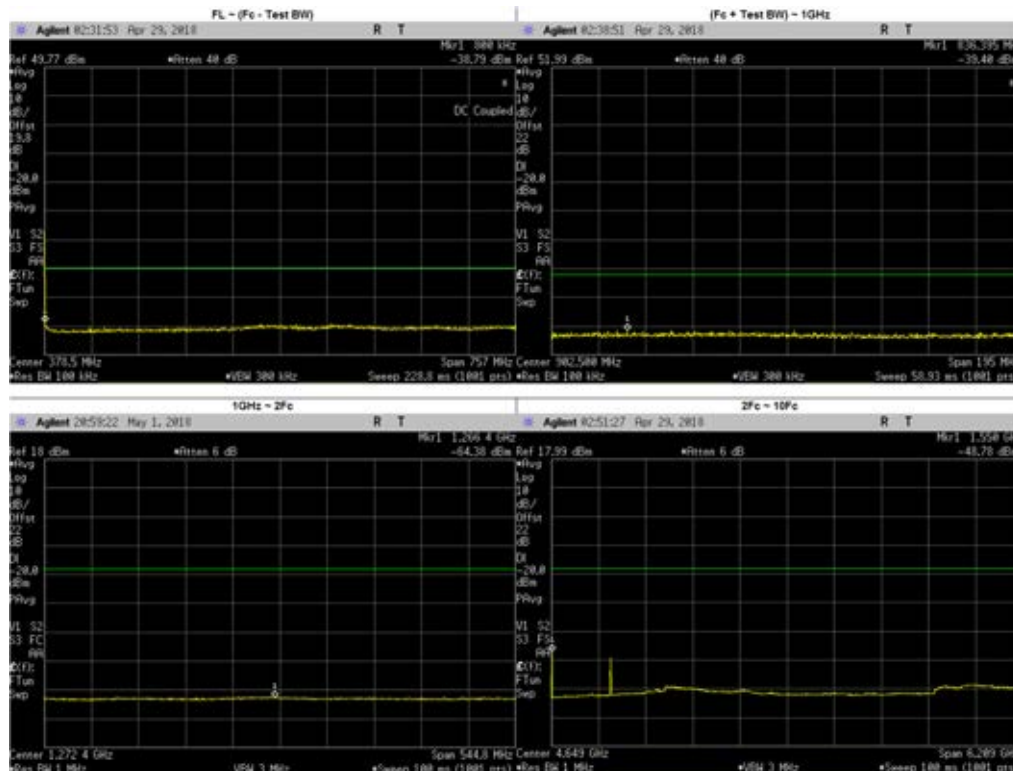

Frequency Range	Highest Spur Frequency (MHz)	Spurious Level (dBm)	Failing Limit (dBm)	Results
FL ~ (Fc - Test BW)	461.0165	-37.99	-20	PASS
(Fc + Test BW) ~ 1GHz	836.3950	-39.40	-20	PASS
1GHz ~ 2Fc	1266.4000	-64.38	-20	PASS
2Fc ~ 10Fc	1550.0000	-48.78	-20	PASS
	2324.6620	-54.79	-20	PASS
	3099.5500	-61.45	-20	PASS
	3874.4370	-63.15	-20	PASS
	4649.3250	-63.77	-20	PASS
	5424.2120	-63.71	-20	PASS
	6199.1000	-63.67	-20	PASS
	6973.9880	-60.98	-20	PASS
	7748.8750	-61.15	-20	PASS

**Analog: 774.8875 MHz, 12.5kHz Channel Spacing, Low Power
 FCC Part 90, RSS 119**

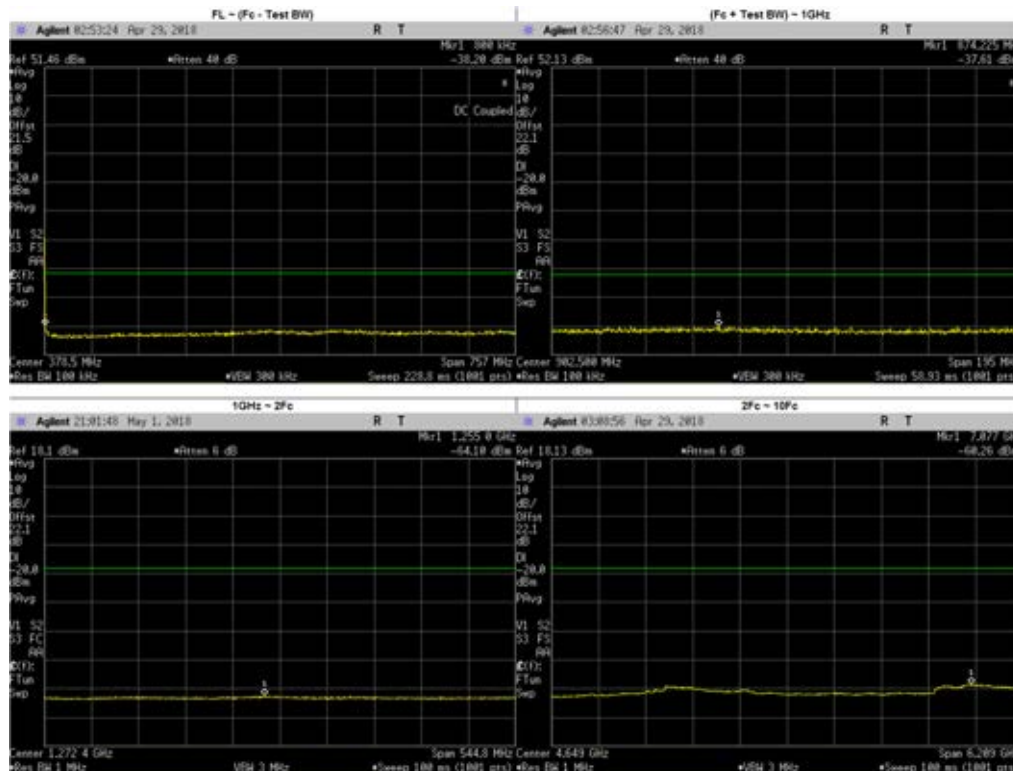

Frequency Range	Highest Spur Frequency (MHz)	Spurious Level (dBm)	Failing Limit (dBm)	Results
FL ~ (Fc - Test BW)	506.4360	-39.65	-20	PASS
(Fc + Test BW) ~ 1GHz	874.2250	-37.61	-20	PASS
1GHz ~ 2Fc	1255.0000	-64.10	-20	PASS
2Fc ~ 10Fc	7077.0830	-60.26	-20	PASS
	1549.7750	-64.64	-20	PASS
	2324.6620	-63.99	-20	PASS
	3099.5500	-61.26	-20	PASS
	3874.4370	-62.75	-20	PASS
	4649.3250	-63.82	-20	PASS
	5424.2120	-63.66	-20	PASS
	6199.1000	-63.37	-20	PASS
	6973.9880	-61.07	-20	PASS
7748.8750	-61.02	-20	PASS	

**Analog: 792.0125 MHz, 12.5kHz Channel Spacing, Max Power
 FCC Part 90, RSS 119**

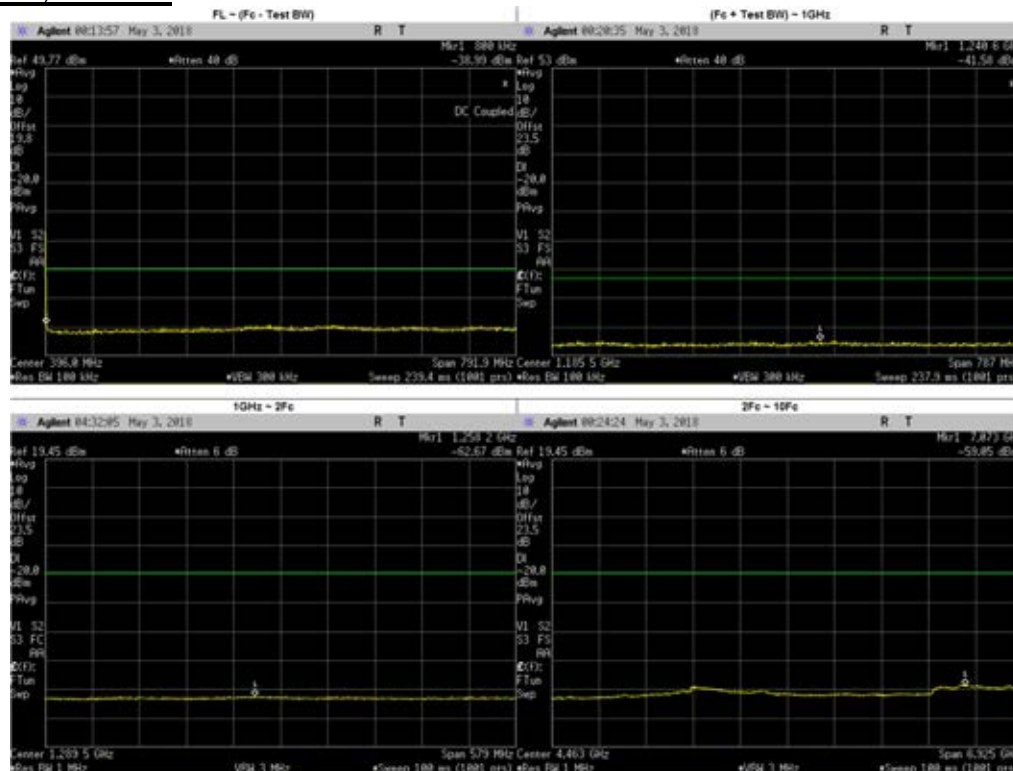

Frequency Range	Highest Spur Frequency (MHz)	Spurious Level (dBm)	Failing Limit (dBm)	Results
FL ~ (Fc - Test BW)	376.9762	-37.85	-20	PASS
(Fc + Test BW) ~ 1GHz	1240.6330	-41.58	-20	PASS
1GHz ~ 2Fc	1258.2000	-62.67	-20	PASS
2Fc ~ 10Fc	7073.3350	-59.05	-20	PASS
	1584.0250	-63.53	-20	PASS
	2376.0370	-62.41	-20	PASS
	3168.0500	-59.82	-20	PASS
	3960.0620	-61.42	-20	PASS
	4752.0750	-62.33	-20	PASS
	5544.0870	-62.54	-20	PASS
	6336.1000	-62.32	-20	PASS
7128.1130	-59.41	-20	PASS	
7920.1250	-59.87	-20	PASS	

**Analog: 792.0125 MHz, 12.5kHz Channel Spacing, Low Power
 FCC Part 90, RSS 119**

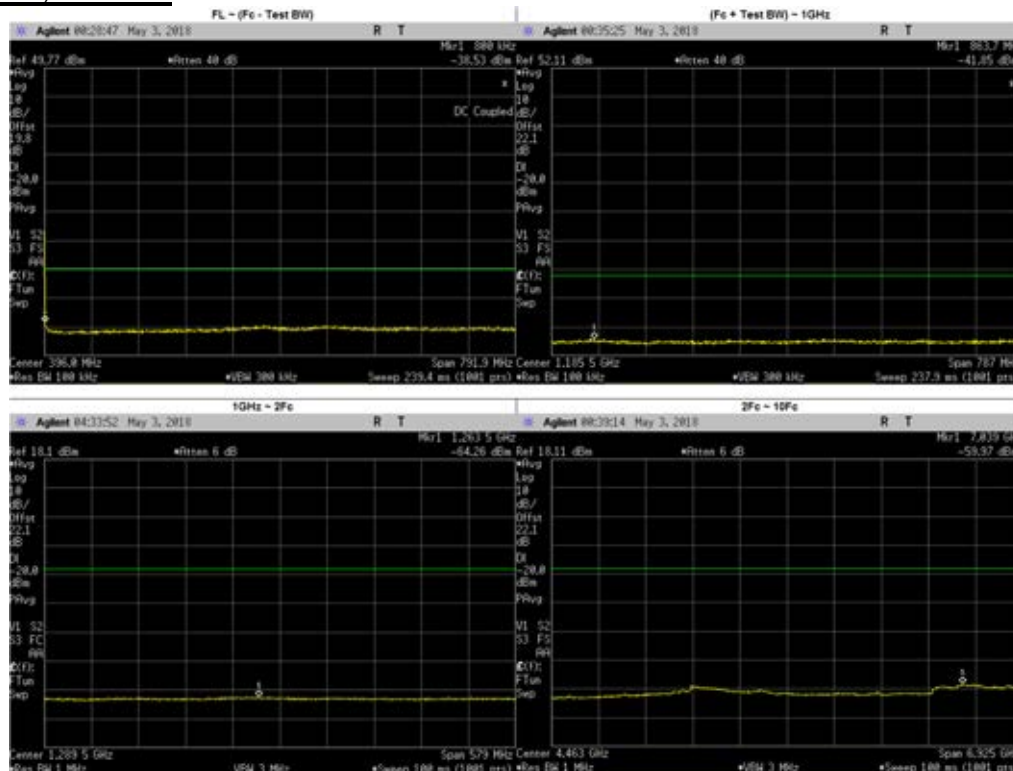

Frequency Range	Highest Spur Frequency (MHz)	Spurious Level (dBm)	Failing Limit (dBm)	Results
FL ~ (Fc - Test BW)	369.8487	-38.08	-20	PASS
(Fc + Test BW) ~ 1GHz	863.7000	-41.85	-20	PASS
1GHz ~ 2Fc	1263.5000	-64.26	-20	PASS
2Fc ~ 10Fc	7039.0000	-59.97	-20	PASS
	1584.0250	-64.82	-20	PASS
	2376.0370	-63.95	-20	PASS
	3168.0500	-61.25	-20	PASS
	3960.0620	-62.97	-20	PASS
	4752.0750	-64.01	-20	PASS
	5544.0870	-64.00	-20	PASS
	6336.1000	-63.41	-20	PASS
7128.1130	-60.80	-20	PASS	
7920.1250	-61.16	-20	PASS	

**Analog: 799.0875 MHz, 12.5kHz Channel Spacing, Max Power
 FCC Part 90, RSS 119**

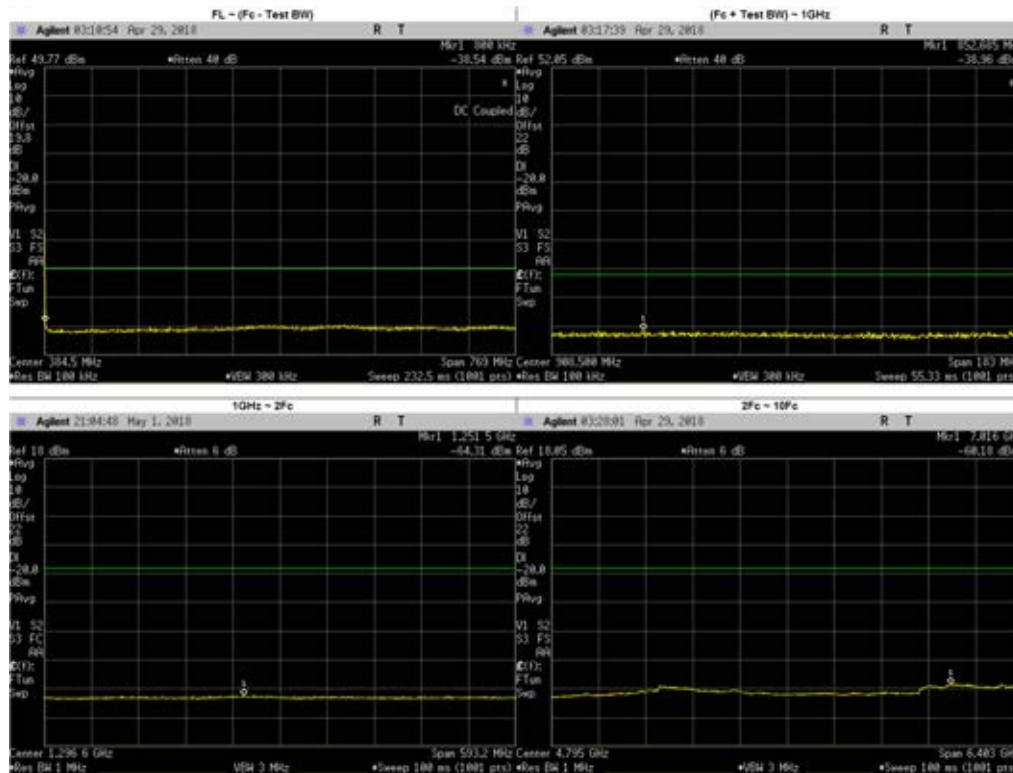

Frequency Range	Highest Spur Frequency (MHz)	Spurious Level (dBm)	Failing Limit (dBm)	Results
FL ~ (Fc - Test BW)	463.7106	-38.35	-20	PASS
(Fc + Test BW) ~ 1GHz	852.6850	-38.96	-20	PASS
1GHz ~ 2Fc	1251.5000	-64.31	-20	PASS
2Fc ~ 10Fc	7016.2620	-60.18	-20	PASS
	1598.1750	-64.74	-20	PASS
	2397.2620	-64.04	-20	PASS
	3196.3500	-61.57	-20	PASS
	3995.4370	-62.88	-20	PASS
	4794.5250	-63.85	-20	PASS
	5593.6130	-64.07	-20	PASS
	6392.7000	-63.70	-20	PASS
	7191.7880	-60.77	-20	PASS
7990.8750	-61.31	-20	PASS	

**Analog: 799.0875 MHz, 12.5kHz Channel Spacing, Low Power
 FCC Part 90, RSS 119**

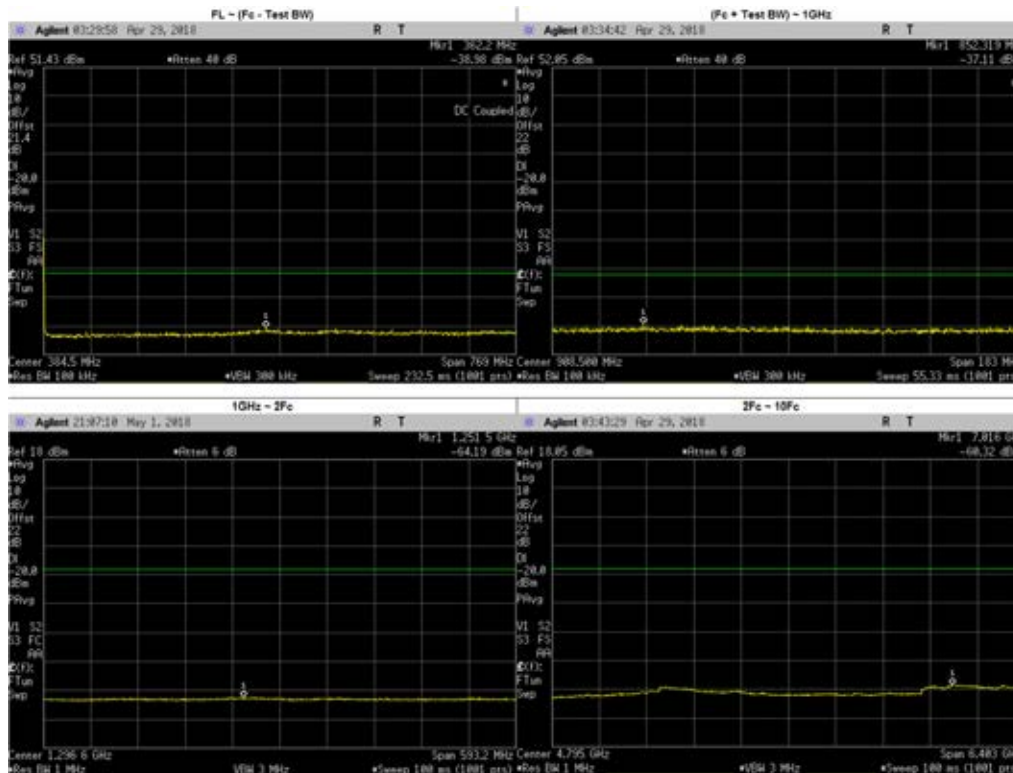

Frequency Range	Highest Spur Frequency (MHz)	Spurious Level (dBm)	Failing Limit (dBm)	Results
FL ~ (Fc - Test BW)	362.2038	-39.17	-20	PASS
(Fc + Test BW) ~ 1GHz	852.3190	-37.11	-20	PASS
1GHz ~ 2Fc	1251.5000	-64.19	-20	PASS
2Fc ~ 10Fc	7016.2620	-60.32	-20	PASS
	1598.1750	-64.88	-20	PASS
	2397.2620	-63.94	-20	PASS
	3196.3500	-61.60	-20	PASS
	3995.4370	-62.86	-20	PASS
	4794.5250	-63.59	-20	PASS
	5593.6130	-63.75	-20	PASS
	6392.7000	-63.49	-20	PASS
	7191.7880	-60.87	-20	PASS
7990.8750	-61.32	-20	PASS	

**Analog: 804.9125 MHz, 12.5kHz Channel Spacing, Max Power
 FCC Part 90, RSS 119**

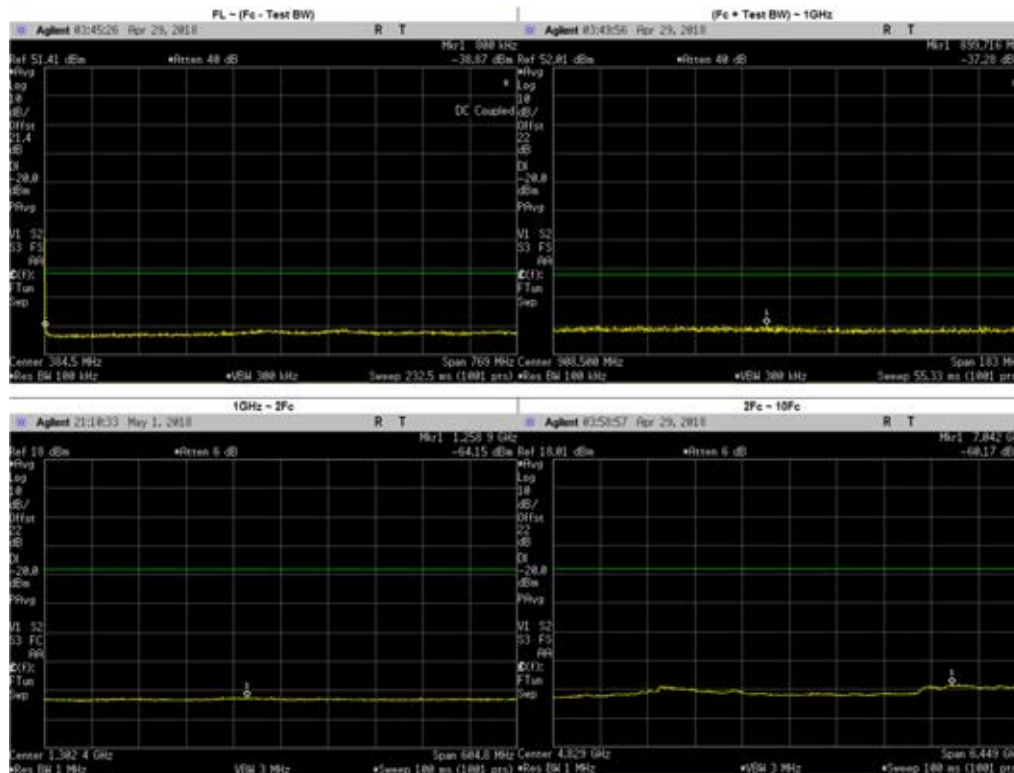

Frequency Range	Highest Spur Frequency (MHz)	Spurious Level (dBm)	Failing Limit (dBm)	Results
FL ~ (Fc - Test BW)	491.3942	-39.49	-20	PASS
(Fc + Test BW) ~ 1GHz	899.7160	-37.28	-20	PASS
1GHz ~ 2Fc	1258.9000	-64.15	-20	PASS
2Fc ~ 10Fc	7041.5850	-60.17	-20	PASS
	1609.8250	-64.75	-20	PASS
	2414.7380	-64.12	-20	PASS
	3219.6500	-61.42	-20	PASS
	4024.5620	-62.76	-20	PASS
	4829.4750	-63.86	-20	PASS
	5634.3870	-63.97	-20	PASS
	6439.3000	-63.74	-20	PASS
	7244.2120	-60.95	-20	PASS
8049.1250	-61.48	-20	PASS	

**Analog: 804.9125 MHz, 12.5kHz Channel Spacing, Low Power
 FCC Part 90, RSS 119**

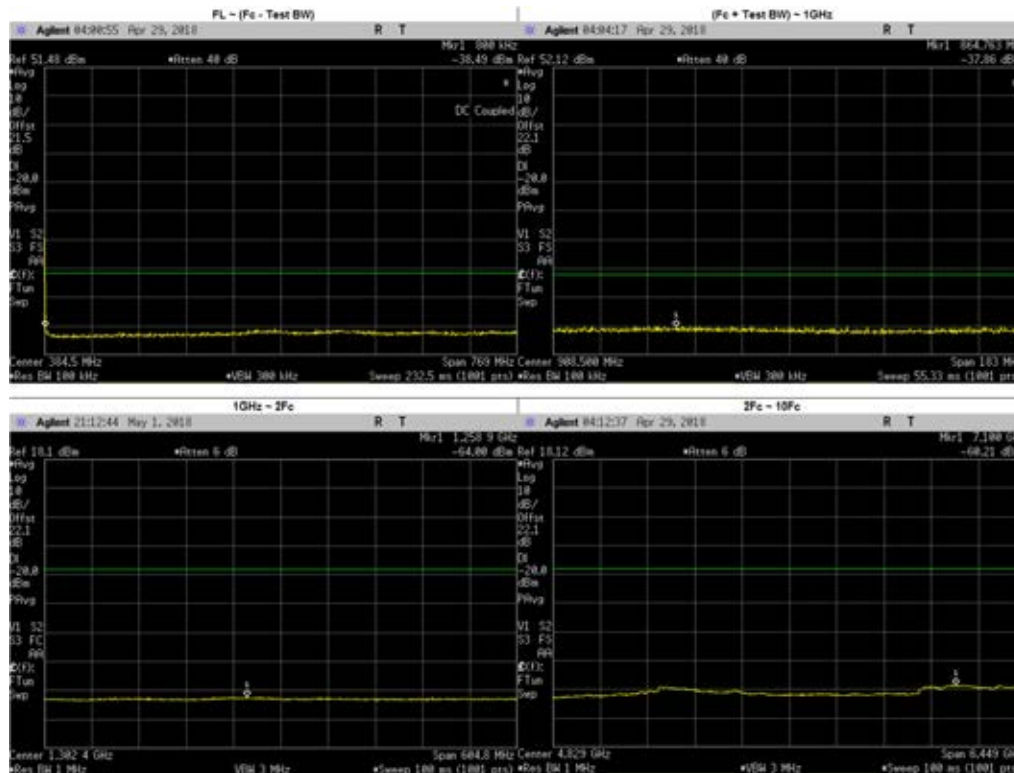

Frequency Range	Highest Spur Frequency (MHz)	Spurious Level (dBm)	Failing Limit (dBm)	Results
FL ~ (Fc - Test BW)	375.2766	-39.66	-20	PASS
(Fc + Test BW) ~ 1GHz	864.7630	-37.86	-20	PASS
1GHz ~ 2Fc	1258.9000	-64.00	-20	PASS
2Fc ~ 10Fc	7099.6290	-60.21	-20	PASS
	1609.8250	-64.68	-20	PASS
	2414.7380	-63.90	-20	PASS
	3219.6500	-61.22	-20	PASS
	4024.5620	-62.75	-20	PASS
	4829.4750	-63.65	-20	PASS
	5634.3870	-63.68	-20	PASS
	6439.3000	-63.69	-20	PASS
	7244.2120	-60.73	-20	PASS
8049.1250	-61.63	-20	PASS	

6.10.3. Test Result (Digital)

C4FM: 762.0125 MHz, 12.5 kHz Channel Spacing, Max Power (Not For FCC Review)

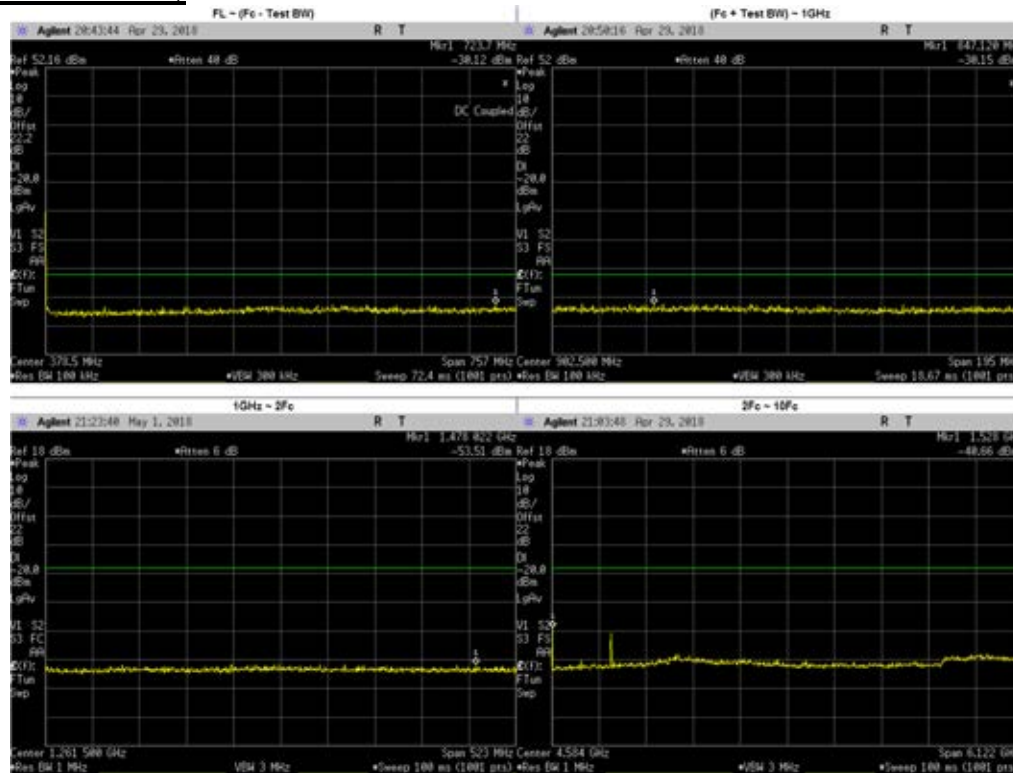

Frequency Range	Highest Spur Frequency (MHz)	Spurious Level (dBm)	Failing Limit (dBm)	Results
FL ~ (Fc - Test BW)	723.7000	-30.12	-20	PASS
(Fc + Test BW) ~ 1GHz	847.1200	-30.51	-20	PASS
1GHz ~ 2Fc	1478.0220	-53.51	-20	PASS
2Fc ~ 10Fc	1528.0000	-40.66	-20	PASS
	2292.0370	-44.80	-20	PASS
	3056.0500	-51.61	-20	PASS
	3820.0620	-53.41	-20	PASS
	4584.0750	-54.21	-20	PASS
	5348.0870	-53.48	-20	PASS
	6112.1000	-53.34	-20	PASS
	6876.1130	-51.70	-20	PASS
	7640.1250	-51.90	-20	PASS

C4FM: 762.0125 MHz, 12.5 kHz Channel Spacing, Low Power
(Not For FCC Review)

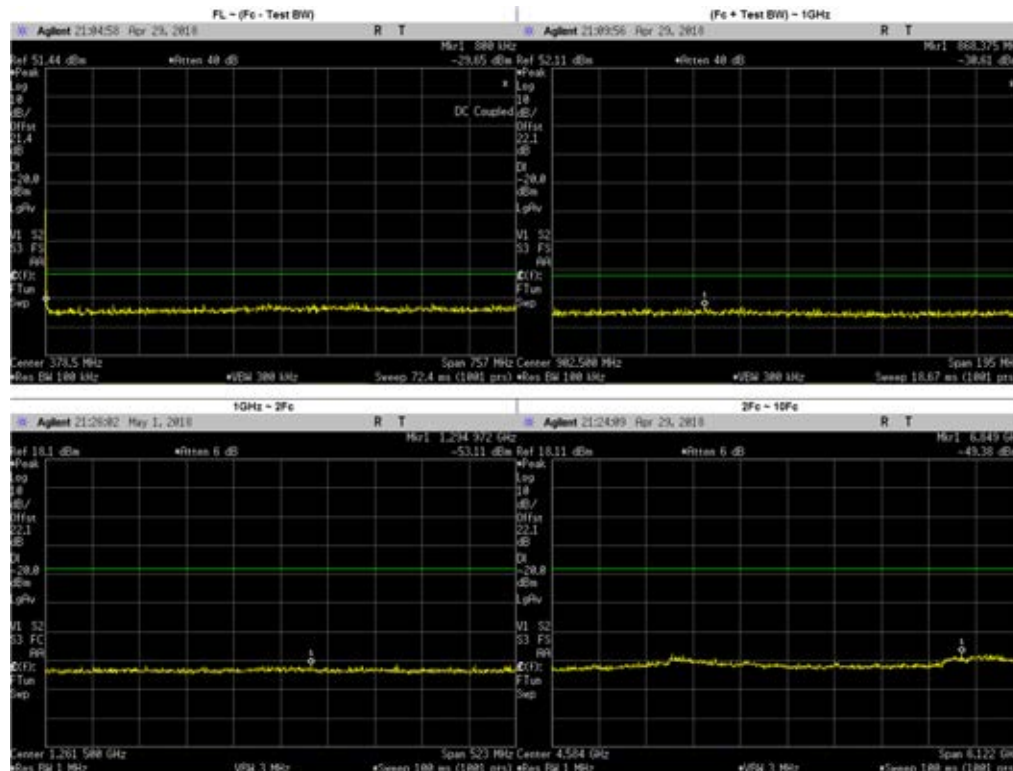

Frequency Range	Highest Spur Frequency (MHz)	Spurious Level (dBm)	Failing Limit (dBm)	Results
FL ~ (Fc - Test BW)	501.8940	-30.36	-20	PASS
(Fc + Test BW) ~ 1GHz	868.3750	-30.96	-20	PASS
1GHz ~ 2Fc	1294.9720	-53.11	-20	PASS
2Fc ~ 10Fc	6849.2520	-49.38	-20	PASS
	1528.0250	-53.93	-20	PASS
	2292.0370	-54.03	-20	PASS
	3056.0500	-51.28	-20	PASS
	3820.0620	-53.11	-20	PASS
	4584.0750	-54.21	-20	PASS
	5348.0870	-54.12	-20	PASS
	6112.1000	-53.10	-20	PASS
	6876.1130	-51.33	-20	PASS
7640.1250	-51.63	-20	PASS	

**C4FM: 769.0125 MHz, 12.5 kHz Channel Spacing, Max Power
 FCC Part 90**

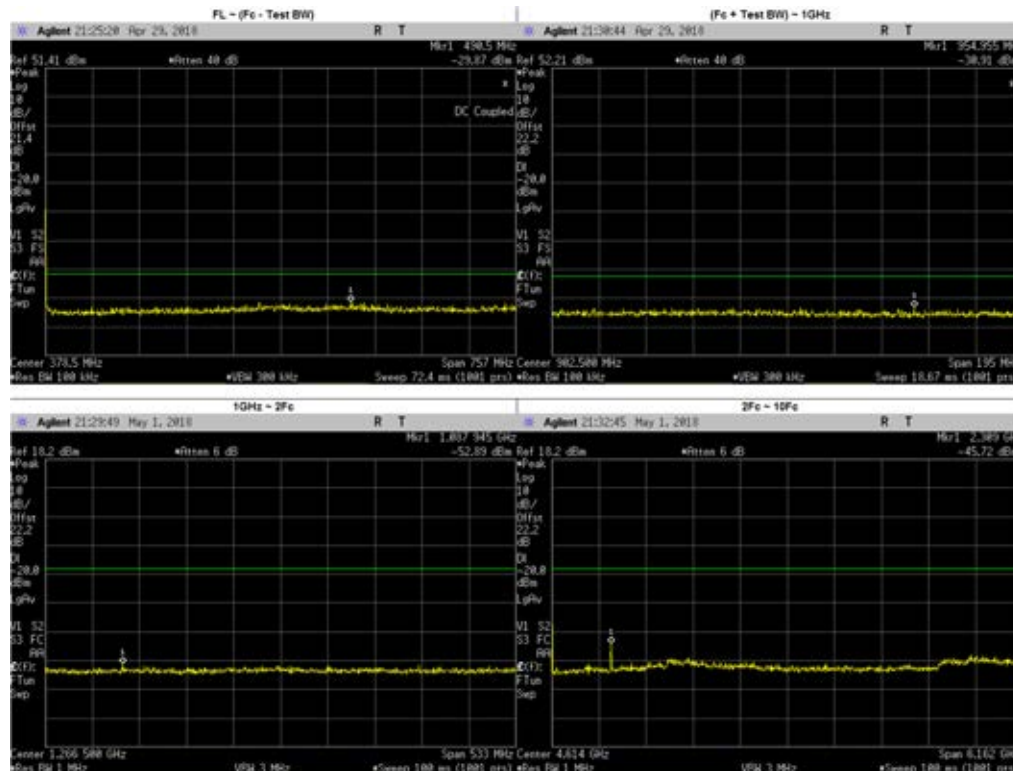

Frequency Range	Highest Spur Frequency (MHz)	Spurious Level (dBm)	Failing Limit (dBm)	Results
FL ~ (Fc - Test BW)	490.5392	-30.10	-20	PASS
(Fc + Test BW) ~ 1GHz	954.9550	-30.91	-20	PASS
1GHz ~ 2Fc	1087.9450	-52.89	-20	PASS
2Fc ~ 10Fc	1538.0250	-43.34	-20	PASS
	2307.0370	-43.07	-20	PASS
	3076.0500	-50.75	-20	PASS
	3845.0620	-52.83	-20	PASS
	4614.0750	-53.61	-20	PASS
	5383.0870	-53.85	-20	PASS
	6152.1000	-54.13	-20	PASS
	6921.1130	-50.85	-20	PASS
	7690.1250	-50.59	-20	PASS
	2309.0000	-45.72	-20	PASS

**C4FM: 769.0875 MHz, 12.5 kHz Channel Spacing, Max Power
 FCC Part 90, RSS 119**

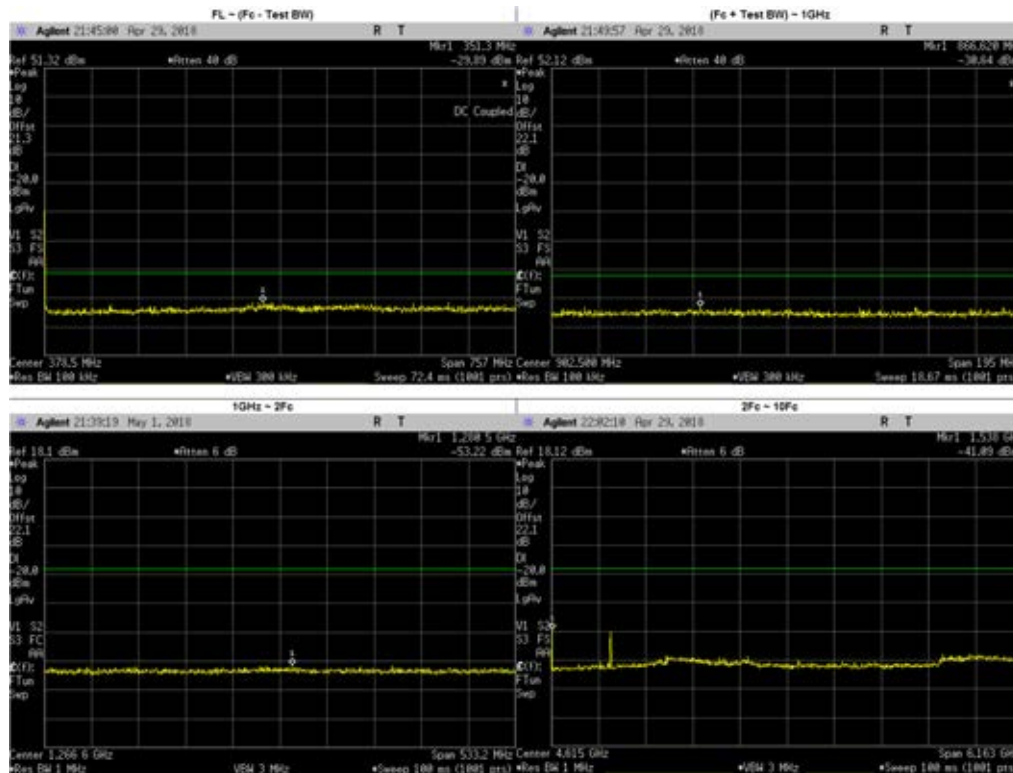

Frequency Range	Highest Spur Frequency (MHz)	Spurious Level (dBm)	Failing Limit (dBm)	Results
FL ~ (Fc - Test BW)	351.3000	-29.89	-20	PASS
(Fc + Test BW) ~ 1GHz	866.6200	-30.64	-20	PASS
1GHz ~ 2Fc	1280.5000	-53.22	-20	PASS
2Fc ~ 10Fc	1538.0000	-41.09	-20	PASS
	2307.2620	-43.71	-20	PASS
	3076.3500	-51.46	-20	PASS
	3845.4370	-53.70	-20	PASS
	4614.5250	-54.06	-20	PASS
	5383.6130	-53.14	-20	PASS
	6152.7000	-53.85	-20	PASS
	6921.7880	-51.50	-20	PASS
	7690.8750	-51.87	-20	PASS

**C4FM: 769.0875 MHz, 12.5 kHz Channel Spacing, Low Power
 FCC Part 90, RSS 119**

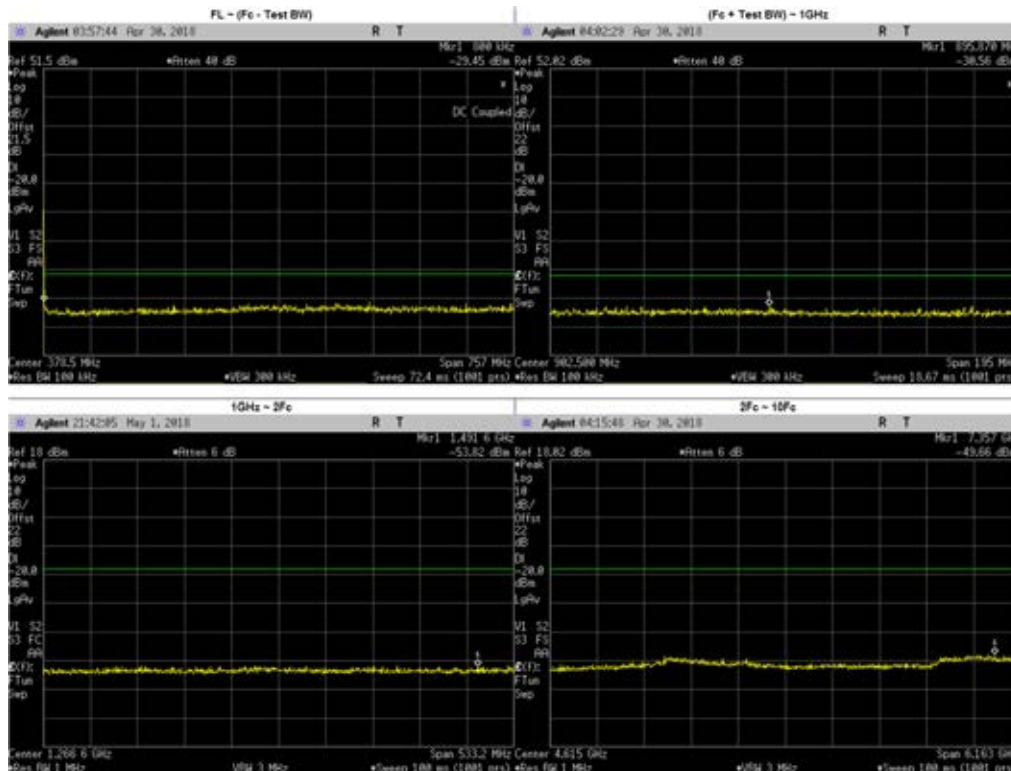

Frequency Range	Highest Spur Frequency (MHz)	Spurious Level (dBm)	Failing Limit (dBm)	Results
FL ~ (Fc - Test BW)	523.8468	-29.94	-20	PASS
(Fc + Test BW) ~ 1GHz	895.8700	-30.56	-20	PASS
1GHz ~ 2Fc	1491.6000	-53.82	-20	PASS
2Fc ~ 10Fc	7356.9260	-49.66	-20	PASS
	1538.1750	-55.14	-20	PASS
	2307.2620	-54.18	-20	PASS
	3076.3500	-51.28	-20	PASS
	3845.4370	-53.56	-20	PASS
	4614.5250	-53.90	-20	PASS
	5383.6130	-53.23	-20	PASS
	6152.7000	-53.54	-20	PASS
	6921.7880	-51.91	-20	PASS
	7690.8750	-51.61	-20	PASS

**C4FM: 774.8875 MHz, 12.5 kHz Channel Spacing, Max Power
 FCC Part 90, RSS-119**

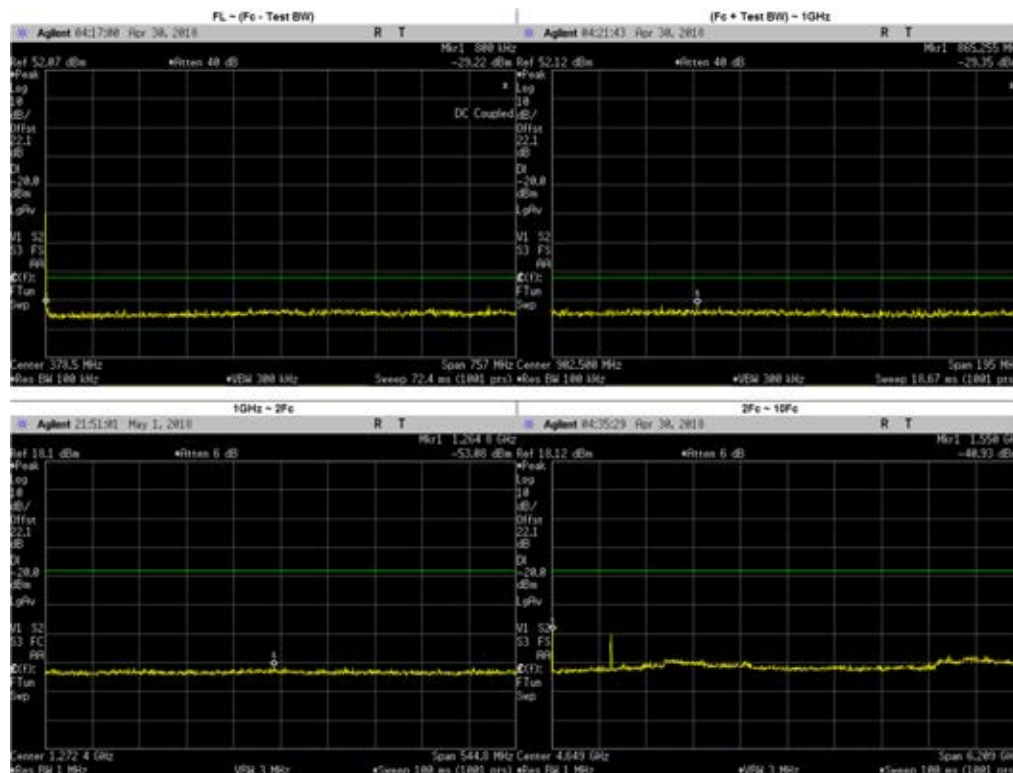

Frequency Range	Highest Spur Frequency (MHz)	Spurious Level (dBm)	Failing Limit (dBm)	Results
FL ~ (Fc - Test BW)	712.3375	-30.33	-20	PASS
(Fc + Test BW) ~ 1GHz	865.2550	-29.35	-20	PASS
1GHz ~ 2Fc	1264.8000	-53.08	-20	PASS
2Fc ~ 10Fc	1550.0000	-40.93	-20	PASS
	2324.6620	-44.10	-20	PASS
	3099.5500	-51.50	-20	PASS
	3874.4370	-53.36	-20	PASS
	4649.3250	-53.01	-20	PASS
	5424.2120	-53.91	-20	PASS
	6199.1000	-53.96	-20	PASS
	6973.9880	-50.78	-20	PASS
	7748.8750	-51.52	-20	PASS

**C4FM: 774.8875 MHz, 12.5 kHz Channel Spacing, Low Power
 FCC Part 90, RSS 119**

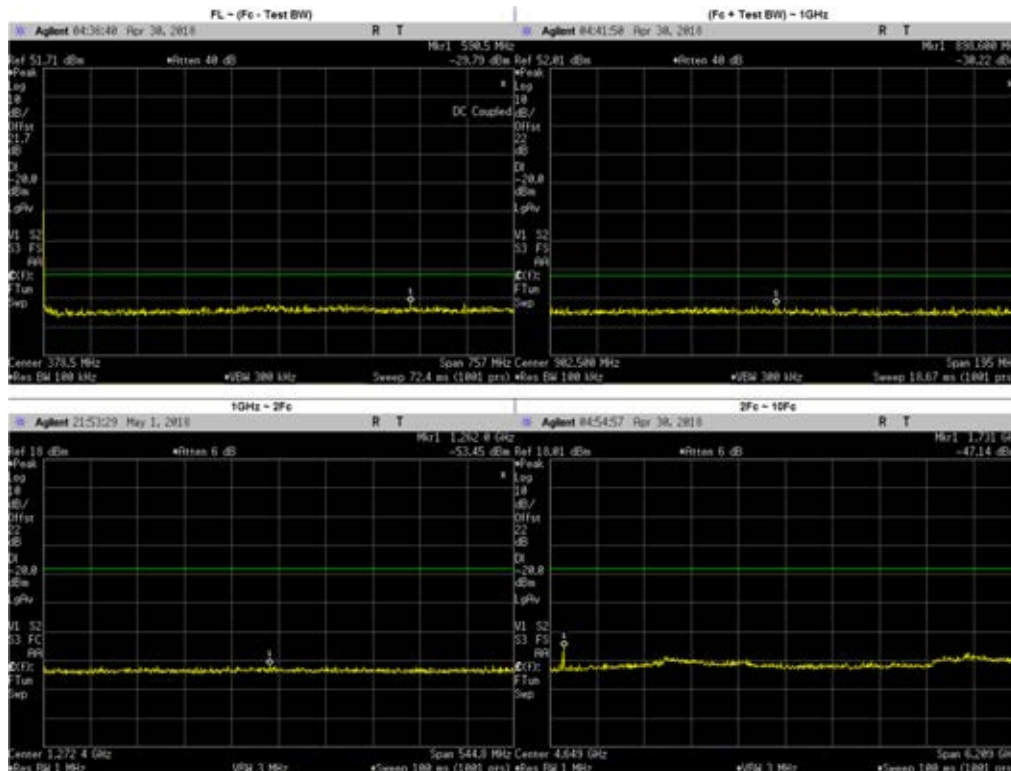

Frequency Range	Highest Spur Frequency (MHz)	Spurious Level (dBm)	Failing Limit (dBm)	Results
FL ~ (Fc - Test BW)	590.5000	-29.79	-20	PASS
(Fc + Test BW) ~ 1GHz	898.6000	-30.22	-20	PASS
1GHz ~ 2Fc	1262.0000	-53.45	-20	PASS
2Fc ~ 10Fc	1731.0480	-47.14	-20	PASS
	1549.7750	-54.53	-20	PASS
	2324.6620	-54.76	-20	PASS
	3099.5500	-51.73	-20	PASS
	3874.4370	-53.06	-20	PASS
	4649.3250	-54.64	-20	PASS
	5424.2120	-54.41	-20	PASS
	6199.1000	-53.88	-20	PASS
6973.9880	-51.54	-20	PASS	
7748.8750	-51.31	-20	PASS	

**C4FM: 799.0875 MHz, 12.5 kHz Channel Spacing, Max Power
 FCC Part 90, RSS 119**

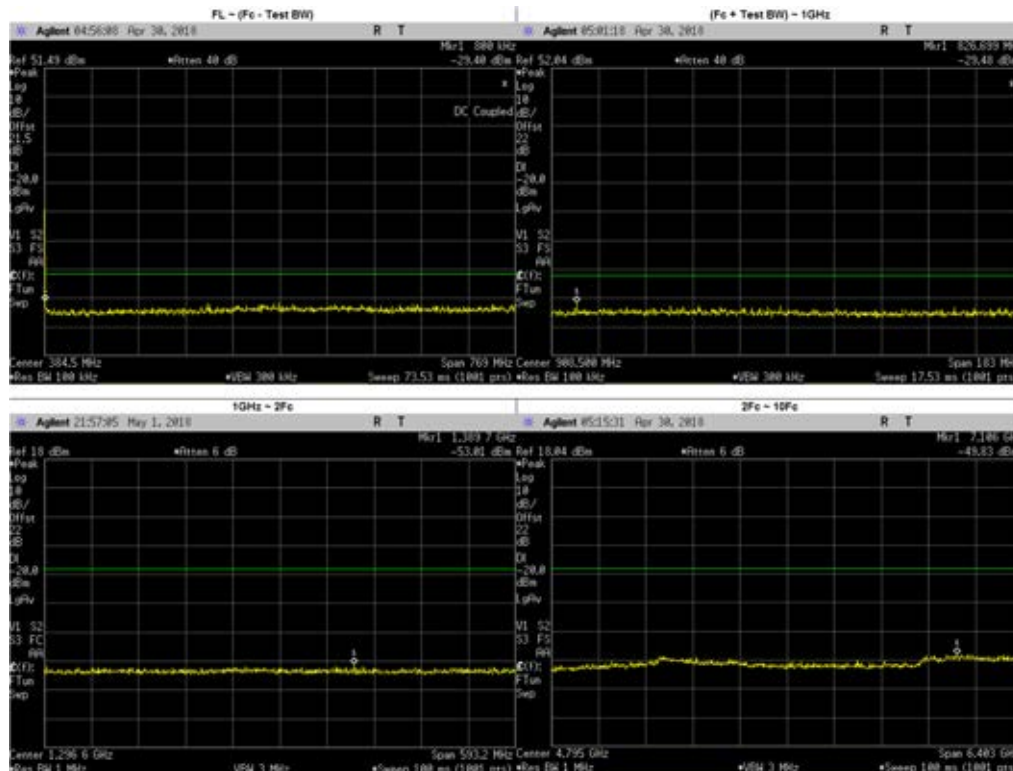

Frequency Range	Highest Spur Frequency (MHz)	Spurious Level (dBm)	Failing Limit (dBm)	Results
FL ~ (Fc - Test BW)	382.9665	-30.25	-20	PASS
(Fc + Test BW) ~ 1GHz	826.6990	-29.48	-20	PASS
1GHz ~ 2Fc	1389.7000	-53.01	-20	PASS
2Fc ~ 10Fc	7106.0000	-49.83	-20	PASS
	1598.1750	-55.15	-20	PASS
	2397.2620	-53.76	-20	PASS
	3196.3500	-51.53	-20	PASS
	3995.4370	-52.69	-20	PASS
	4794.5250	-55.04	-20	PASS
	5593.6130	-53.79	-20	PASS
	6392.7000	-53.43	-20	PASS
7191.7880	-51.06	-20	PASS	
7990.8750	-51.57	-20	PASS	

**C4FM: 799.0875 MHz, 12.5 kHz Channel Spacing, Low Power
 FCC Part 90, RSS 119**

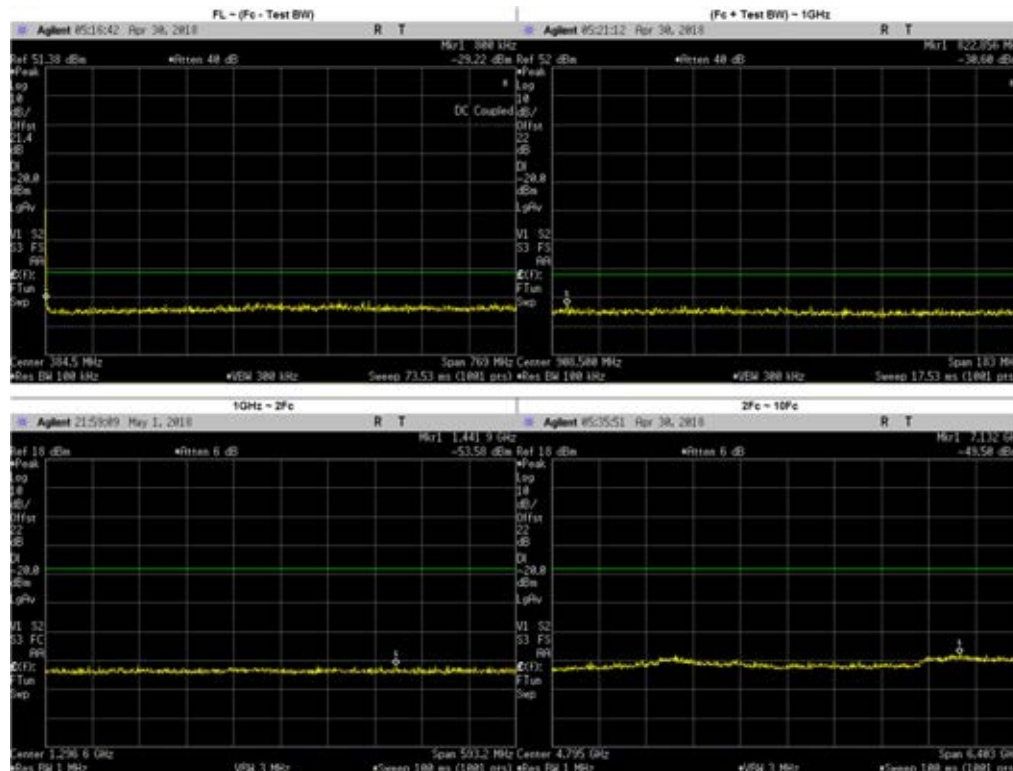

Frequency Range	Highest Spur Frequency (MHz)	Spurious Level (dBm)	Failing Limit (dBm)	Results
FL ~ (Fc - Test BW)	481.3974	-30.11	-20	PASS
(Fc + Test BW) ~ 1GHz	822.8560	-30.60	-20	PASS
1GHz ~ 2Fc	1441.9000	-53.58	-20	PASS
2Fc ~ 10Fc	7132.0000	-49.50	-20	PASS
	1598.1750	-55.49	-20	PASS
	2397.2620	-54.31	-20	PASS
	3196.3500	-51.95	-20	PASS
	3995.4370	-52.96	-20	PASS
	4794.5250	-53.46	-20	PASS
	5593.6130	-53.68	-20	PASS
	6392.7000	-53.43	-20	PASS
	7191.7880	-51.31	-20	PASS
7990.8750	-50.90	-20	PASS	

**C4FM: 804.9125 MHz, 12.5 kHz Channel Spacing, Max Power
 FCC Part 90, RSS 119**

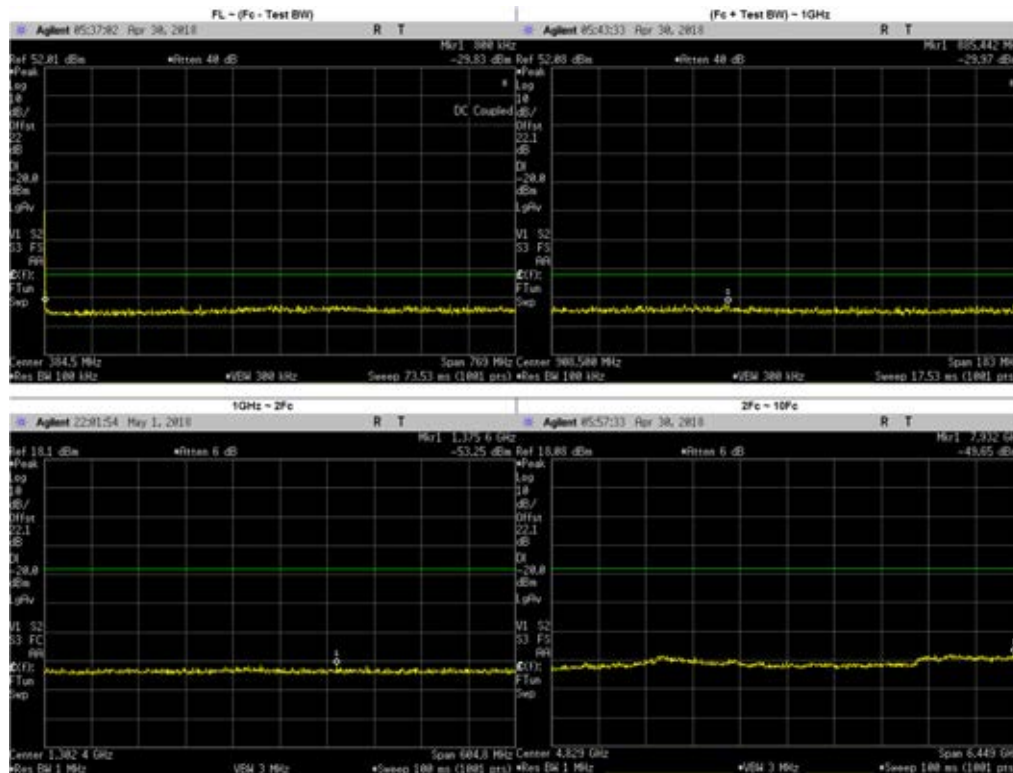

Frequency Range	Highest Spur Frequency (MHz)	Spurious Level (dBm)	Failing Limit (dBm)	Results
FL ~ (Fc - Test BW)	661.3413	-30.74	-20	PASS
(Fc + Test BW) ~ 1GHz	885.4420	-29.97	-20	PASS
1GHz ~ 2Fc	1375.6000	-53.25	-20	PASS
2Fc ~ 10Fc	7932.0000	-49.65	-20	PASS
	1609.8250	-54.40	-20	PASS
	2414.7380	-54.29	-20	PASS
	3219.6500	-51.60	-20	PASS
	4024.5620	-52.77	-20	PASS
	4829.4750	-52.33	-20	PASS
	5634.3870	-54.16	-20	PASS
	6439.3000	-53.09	-20	PASS
	7244.2120	-51.16	-20	PASS
	8049.1250	-52.11	-20	PASS

**C4FM: 804.9125 MHz, 12.5 kHz Channel Spacing, Low Power
 FCC Part 90, RSS 119**

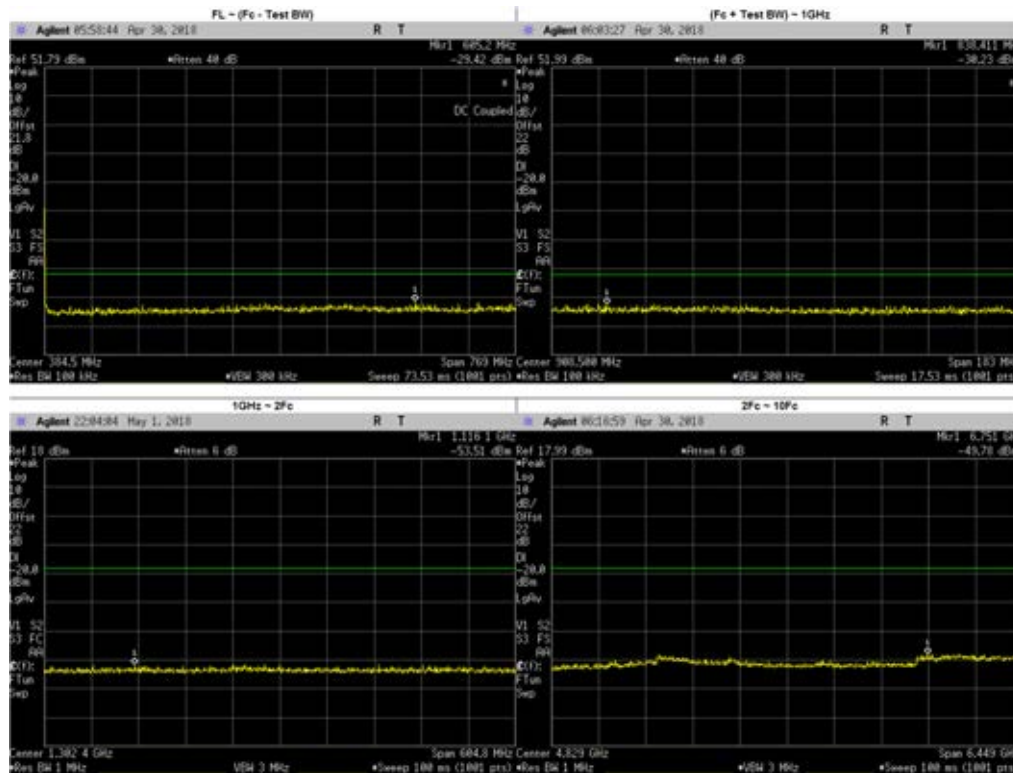

Frequency Range	Highest Spur Frequency (MHz)	Spurious Level (dBm)	Failing Limit (dBm)	Results
FL ~ (Fc - Test BW)	605.2049	-29.42	-20	PASS
(Fc + Test BW) ~ 1GHz	838.4110	-30.61	-20	PASS
1GHz ~ 2Fc	1116.1000	-53.51	-20	PASS
2Fc ~ 10Fc	6751.3660	-49.78	-20	PASS
	1609.8250	-54.97	-20	PASS
	2414.7380	-53.55	-20	PASS
	3219.6500	-51.27	-20	PASS
	4024.5620	-52.52	-20	PASS
	4829.4750	-53.29	-20	PASS
	5634.3870	-53.98	-20	PASS
	6439.3000	-54.16	-20	PASS
	7244.2120	-50.98	-20	PASS
	8049.1250	-51.28	-20	PASS

Phase II: 762.0125 MHz, 12.5 kHz Channel Spacing, Max Power
(Not For FCC Review)

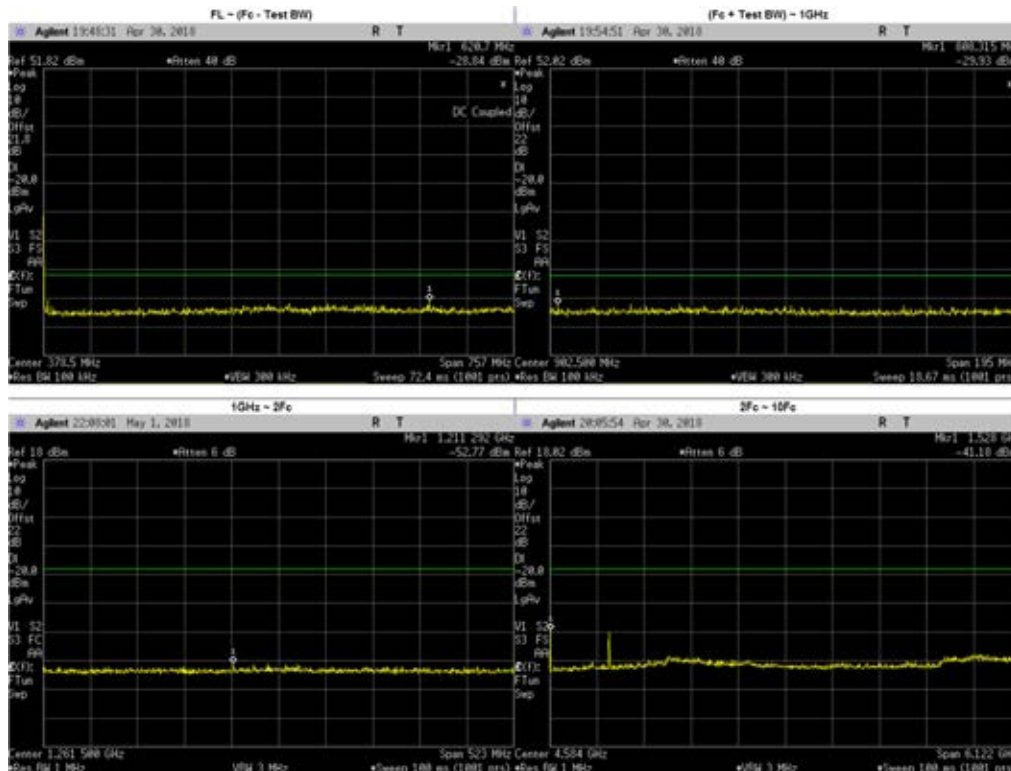

Frequency Range	Highest Spur Frequency (MHz)	Spurious Level (dBm)	Failing Limit (dBm)	Results
FL ~ (Fc - Test BW)	620.7000	-29.15	-20	PASS
(Fc + Test BW) ~ 1GHz	808.3150	-29.93	-20	PASS
1GHz ~ 2Fc	1211.2920	-52.77	-20	PASS
2Fc ~ 10Fc	1528.0000	-41.18	-20	PASS
	2292.0370	-44.03	-20	PASS
	3056.0500	-51.36	-20	PASS
	3820.0620	-53.05	-20	PASS
	4584.0750	-53.94	-20	PASS
	5348.0870	-54.41	-20	PASS
	6112.1000	-53.91	-20	PASS
	6876.1130	-52.14	-20	PASS
	7640.1250	-50.62	-20	PASS

**Phase II: 762.0125 MHz, 12.5 kHz Channel Spacing, Low Power
 (Not For FCC Review)**

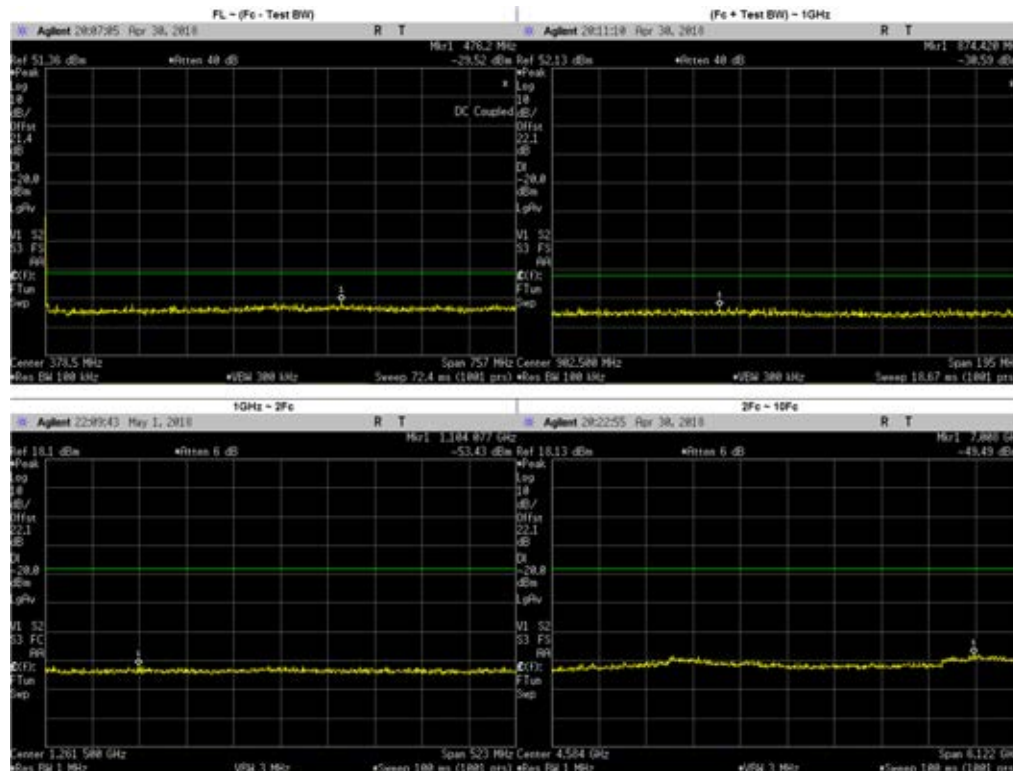

Frequency Range	Highest Spur Frequency (MHz)	Spurious Level (dBm)	Failing Limit (dBm)	Results
FL ~ (Fc - Test BW)	476.2000	-29.52	-20	PASS
(Fc + Test BW) ~ 1GHz	874.4200	-30.59	-20	PASS
1GHz ~ 2Fc	1104.0770	-53.43	-20	PASS
2Fc ~ 10Fc	7008.4270	-49.49	-20	PASS
	1528.0250	-54.90	-20	PASS
	2292.0370	-54.54	-20	PASS
	3056.0500	-51.17	-20	PASS
	3820.0620	-53.57	-20	PASS
	4584.0750	-54.08	-20	PASS
	5348.0870	-53.79	-20	PASS
	6112.1000	-53.22	-20	PASS
6876.1130	-51.50	-20	PASS	
7640.1250	-51.21	-20	PASS	

**Phase II: 769.0125 MHz, 12.5 kHz Channel Spacing, Max Power
 FCC Part 90**

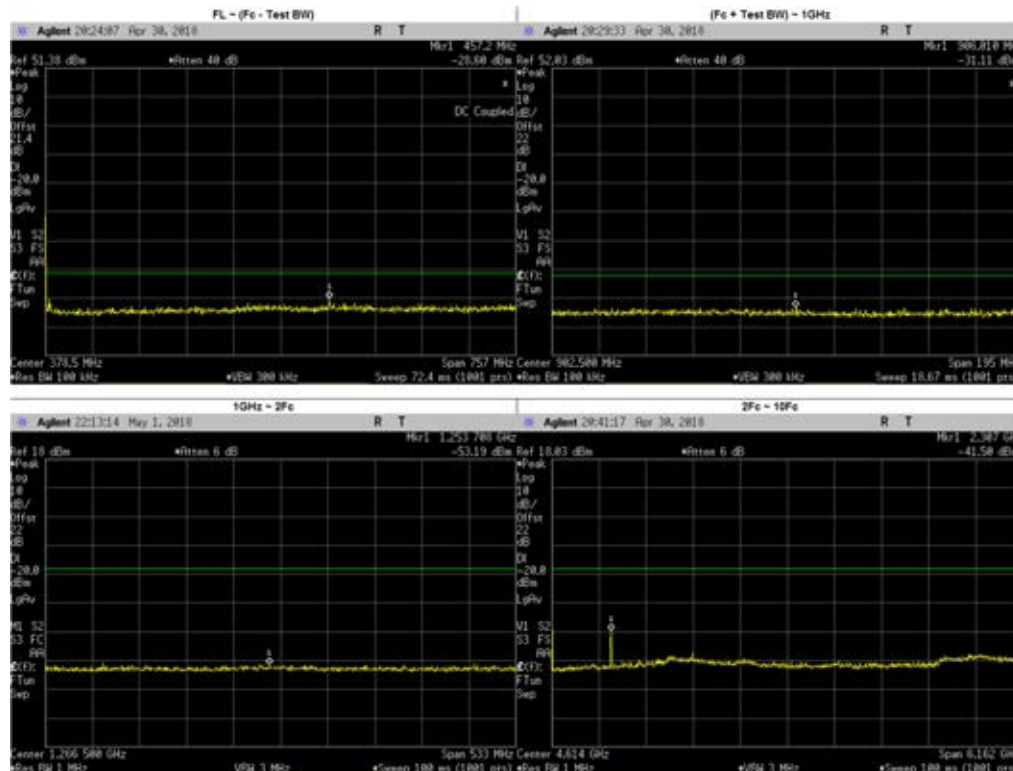

Frequency Range	Highest Spur Frequency (MHz)	Spurious Level (dBm)	Failing Limit (dBm)	Results
FL ~ (Fc - Test BW)	457.2000	-28.60	-20	PASS
(Fc + Test BW) ~ 1GHz	906.0100	-31.11	-20	PASS
1GHz ~ 2Fc	1253.7080	-53.19	-20	PASS
2Fc ~ 10Fc	1538.0250	-43.86	-20	PASS
	2307.0000	-41.50	-20	PASS
	3076.0500	-50.79	-20	PASS
	3845.0620	-52.74	-20	PASS
	4614.0750	-53.65	-20	PASS
	5383.0870	-53.59	-20	PASS
	6152.1000	-53.46	-20	PASS
	6921.1130	-51.38	-20	PASS
	7690.1250	-51.05	-20	PASS

**Phase II: 769.0875 MHz, 12.5 kHz Channel Spacing, Max Power
 FCC Part 90, RSS 119**

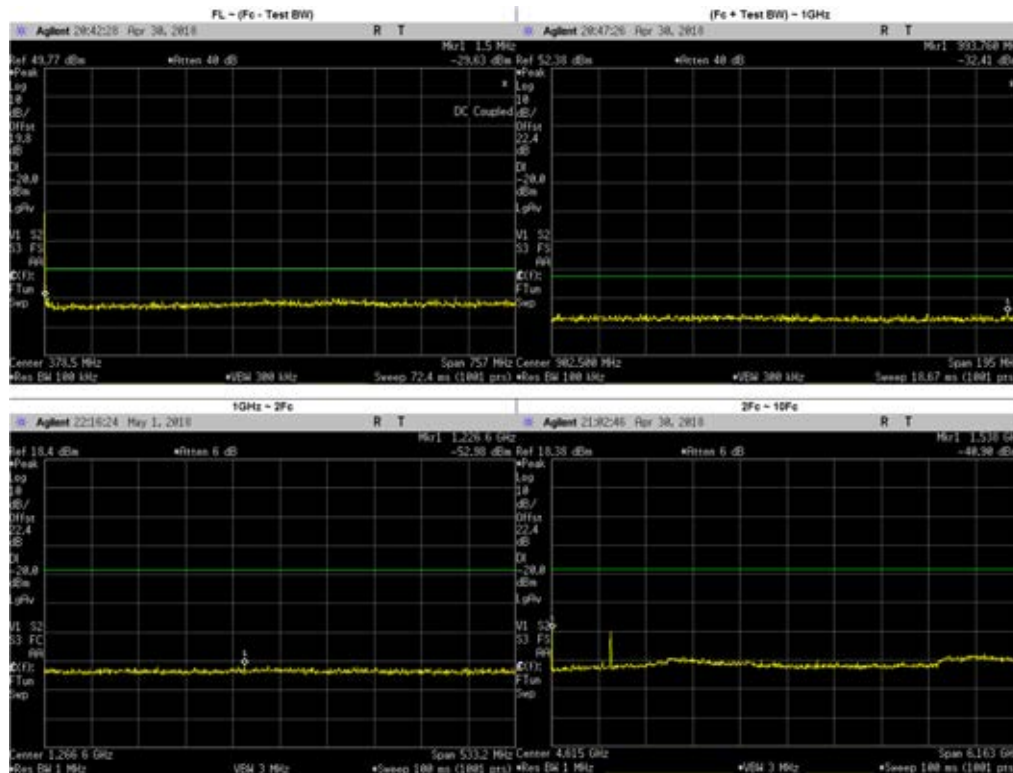

Frequency Range	Highest Spur Frequency (MHz)	Spurious Level (dBm)	Failing Limit (dBm)	Results
FL ~ (Fc - Test BW)	660.1052	-28.04	-20	PASS
(Fc + Test BW) ~ 1GHz	993.7600	-32.41	-20	PASS
1GHz ~ 2Fc	12266.0000	-52.98	-20	PASS
2Fc ~ 10Fc	1538.1750	-40.90	-20	PASS
	2307.2620	-43.58	-20	PASS
	3076.3500	-51.56	-20	PASS
	3845.4370	-53.05	-20	PASS
	4614.5250	-54.21	-20	PASS
	5383.6130	-53.88	-20	PASS
	6152.7000	-53.24	-20	PASS
	6921.7880	-50.95	-20	PASS
	7690.8750	-50.72	-20	PASS

**Phase II: 769.0875 MHz, 12.5 kHz Channel Spacing, Low Power
 FCC Part 90, RSS 119**

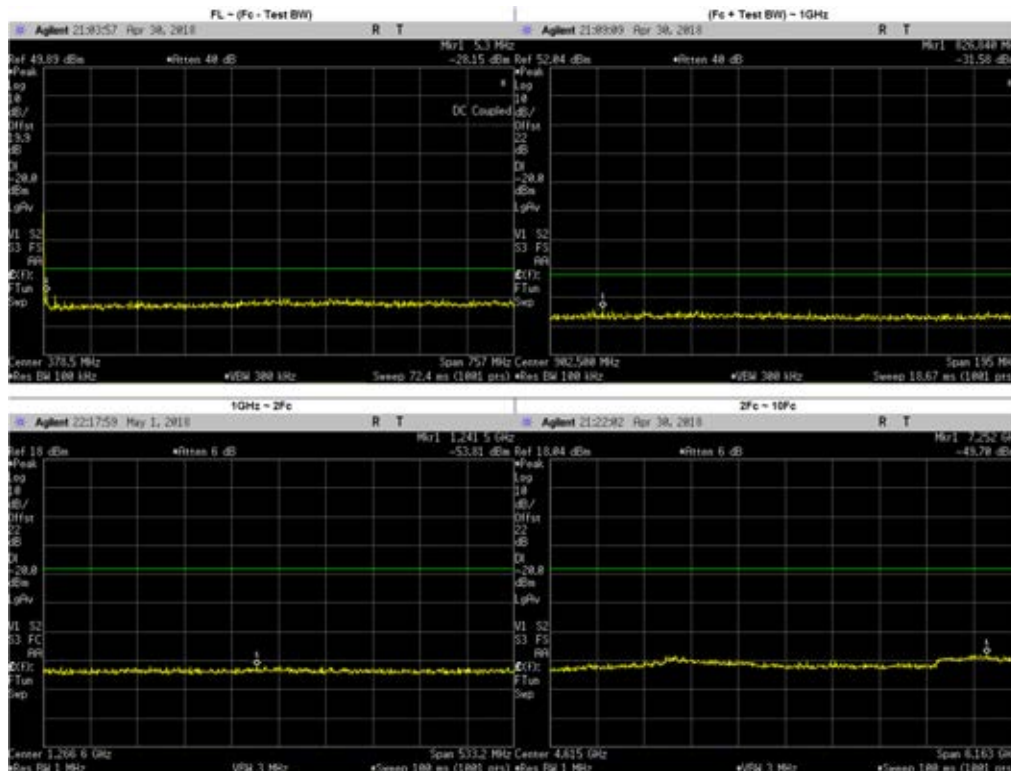

Frequency Range	Highest Spur Frequency (MHz)	Spurious Level (dBm)	Failing Limit (dBm)	Results
FL ~ (Fc - Test BW)	5.3079	-28.15	-20	PASS
(Fc + Test BW) ~ 1GHz	826.8400	-31.58	-20	PASS
1GHz ~ 2Fc	1241.5000	-53.81	-20	PASS
2Fc ~ 10Fc	7252.1610	-49.70	-20	PASS
	1538.1750	-55.35	-20	PASS
	2307.2620	-54.57	-20	PASS
	3076.3500	-51.59	-20	PASS
	3845.4370	-53.08	-20	PASS
	4614.5250	-54.25	-20	PASS
	5383.6130	-54.02	-20	PASS
	6152.7000	-53.28	-20	PASS
6921.7880	-51.91	-20	PASS	
7690.8750	-51.55	-20	PASS	

**Phase II: 774.8875 MHz, 12.5 kHz Channel Spacing, Max Power
 FCC Part 90, RSS 119**

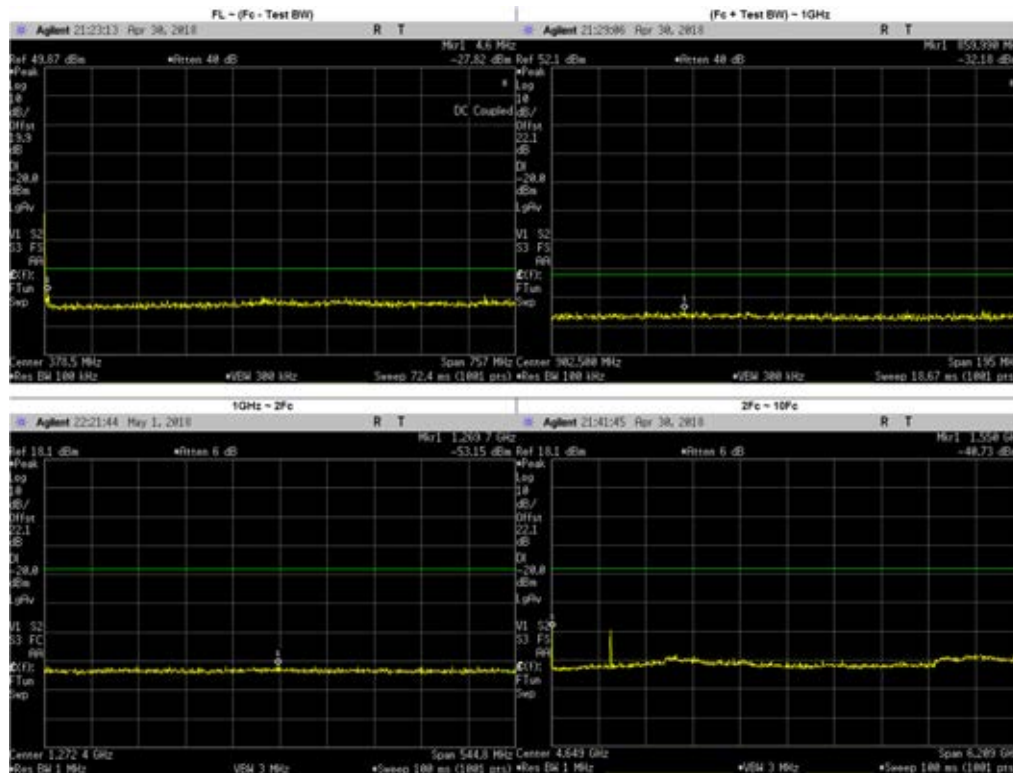

Frequency Range	Highest Spur Frequency (MHz)	Spurious Level (dBm)	Failing Limit (dBm)	Results
FL ~ (Fc - Test BW)	707.7956	-27.28	-20	PASS
(Fc + Test BW) ~ 1GHz	859.9900	-32.18	-20	PASS
1GHz ~ 2Fc	1269.7000	-53.15	-20	PASS
2Fc ~ 10Fc	2320.9120	-46.51	-20	PASS
	1550.0000	-40.73	-20	PASS
	2324.6620	-43.45	-20	PASS
	3099.5500	-51.04	-20	PASS
	3874.4370	-52.91	-20	PASS
	4649.3250	-52.73	-20	PASS
	5424.2120	-53.87	-20	PASS
	6199.1000	-52.94	-20	PASS
	6973.9880	-50.93	-20	PASS
7748.8750	-51.69	-20	PASS	

**Phase II: 774.8875 MHz, 12.5 kHz Channel Spacing, Low Power
 FCC Part 90, RSS 119**

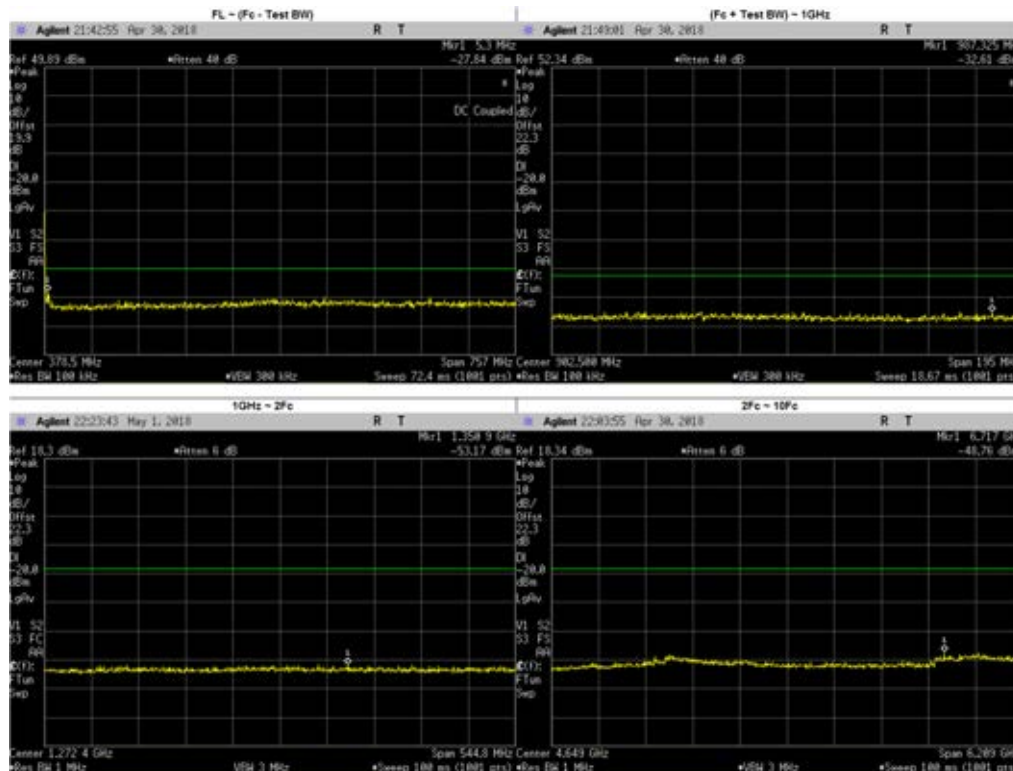

Frequency Range	Highest Spur Frequency (MHz)	Spurious Level (dBm)	Failing Limit (dBm)	Results
FL ~ (Fc - Test BW)	450.4186	-28.73	-20	PASS
(Fc + Test BW) ~ 1GHz	987.3250	-32.61	-20	PASS
1GHz ~ 2Fc	1350.9000	-53.17	-20	PASS
2Fc ~ 10Fc	6717.0000	-48.76	-20	PASS
	1549.7750	-54.50	-20	PASS
	2324.6620	-53.92	-20	PASS
	3099.5500	-50.41	-20	PASS
	3874.4370	-52.87	-20	PASS
	4649.3250	-54.16	-20	PASS
	5424.2120	-53.53	-20	PASS
	6199.1000	-53.49	-20	PASS
	6973.9880	-50.73	-20	PASS
7748.8750	-51.03	-20	PASS	

**Phase II: 799.0875 MHz, 12.5 kHz Channel Spacing, Max Power
 FCC Part 90, RSS 119**

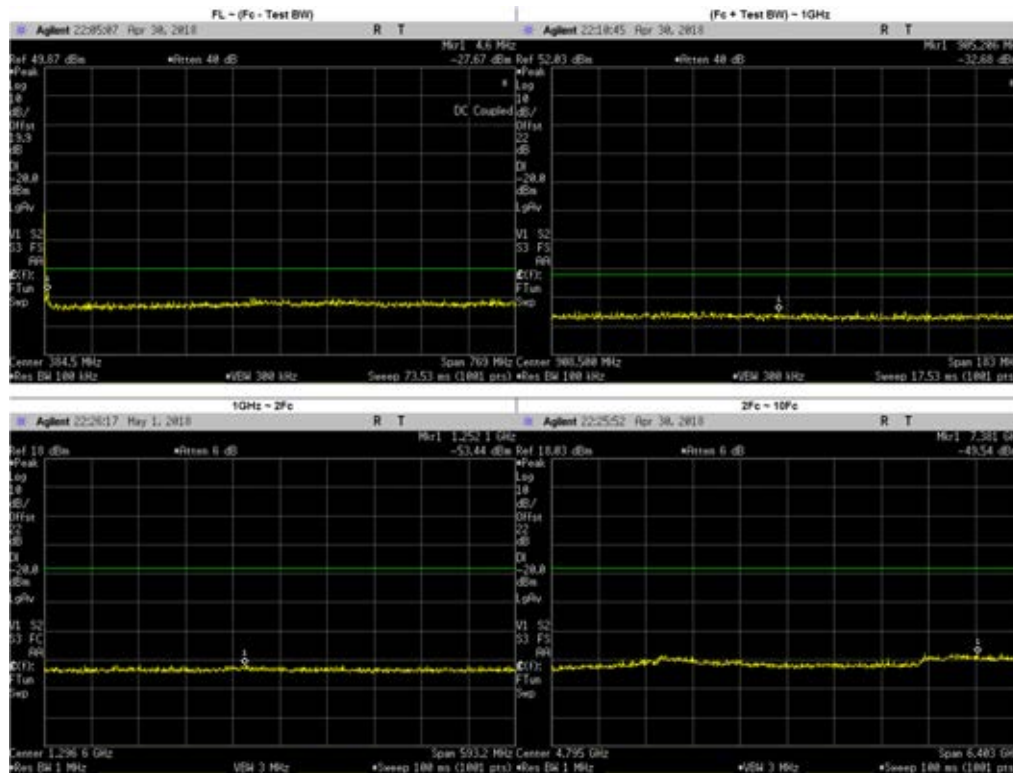

Frequency Range	Highest Spur Frequency (MHz)	Spurious Level (dBm)	Failing Limit (dBm)	Results
FL ~ (Fc - Test BW)	506.0051	-28.86	-20	PASS
(Fc + Test BW) ~ 1GHz	905.2060	-32.68	-20	PASS
1GHz ~ 2Fc	1252.1000	-53.44	-20	PASS
2Fc ~ 10Fc	7381.2160	-49.54	-20	PASS
	1598.1750	-54.54	-20	PASS
	2397.2620	-53.94	-20	PASS
	3196.3500	-51.99	-20	PASS
	3995.4370	-53.51	-20	PASS
	4794.5250	-53.40	-20	PASS
	5593.6130	-53.92	-20	PASS
	6392.7000	-53.56	-20	PASS
	7191.7880	-50.37	-20	PASS
	7990.8750	-51.62	-20	PASS

**Phase II: 799.0875 MHz, 12.5 kHz Channel Spacing, Low Power
 FCC Part 90, RSS 119**

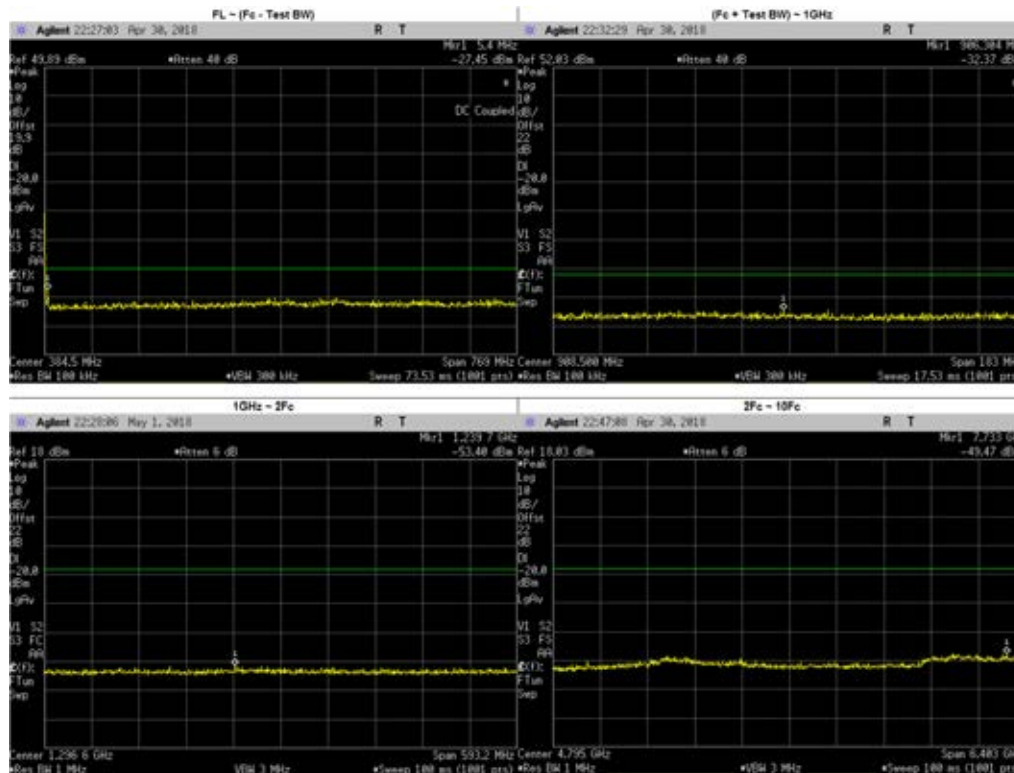

Frequency Range	Highest Spur Frequency (MHz)	Spurious Level (dBm)	Failing Limit (dBm)	Results
FL ~ (Fc - Test BW)	374.5076	-28.93	-20	PASS
(Fc + Test BW) ~ 1GHz	906.3040	-32.37	-20	PASS
1GHz ~ 2Fc	1239.7000	-53.40	-20	PASS
2Fc ~ 10Fc	7733.3640	-49.47	-20	PASS
	1598.1750	-54.72	-20	PASS
	2397.2620	-53.82	-20	PASS
	3196.3500	-51.46	-20	PASS
	3995.4370	-52.13	-20	PASS
	4794.5250	-54.51	-20	PASS
	5593.6130	-53.74	-20	PASS
	6392.7000	-54.33	-20	PASS
7191.7880	-51.07	-20	PASS	
7990.8750	-51.44	-20	PASS	

**Phase II: 804.9125 MHz, 12.5 kHz Channel Spacing, Max Power
 FCC Part 90, RSS 119**

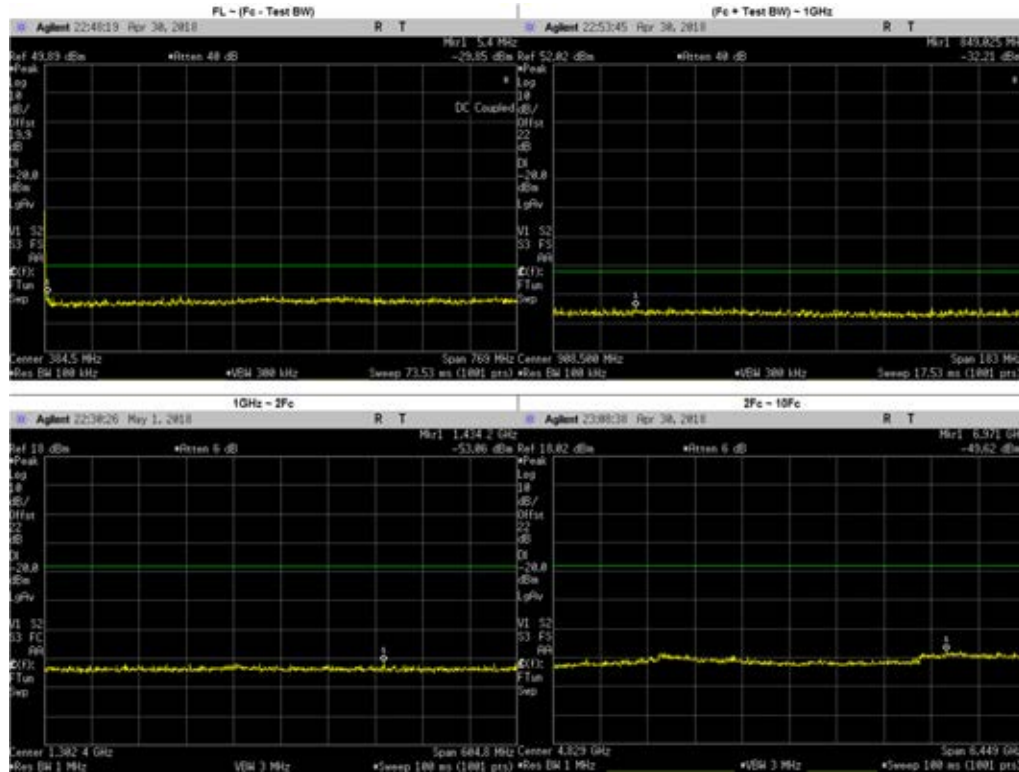

Frequency Range	Highest Spur Frequency (MHz)	Spurious Level (dBm)	Failing Limit (dBm)	Results
FL ~ (Fc - Test BW)	487.5493	-29.25	-20	PASS
(Fc + Test BW) ~ 1GHz	849.0250	-32.21	-20	PASS
1GHz ~ 2Fc	1434.2000	-53.06	-20	PASS
2Fc ~ 10Fc	6971.0000	-49.62	-20	PASS
	1609.8250	-55.36	-20	PASS
	2414.7380	-54.07	-20	PASS
	3219.6500	-52.01	-20	PASS
	4024.5620	-52.88	-20	PASS
	4829.4750	-54.22	-20	PASS
	5634.3870	-54.27	-20	PASS
	6439.3000	-53.95	-20	PASS
	7244.2120	-51.28	-20	PASS
8049.1250	-51.38	-20	PASS	

**Phase II: 804.9125 MHz, 12.5 kHz Channel Spacing, Low Power
 FCC Part 90, RSS 119**

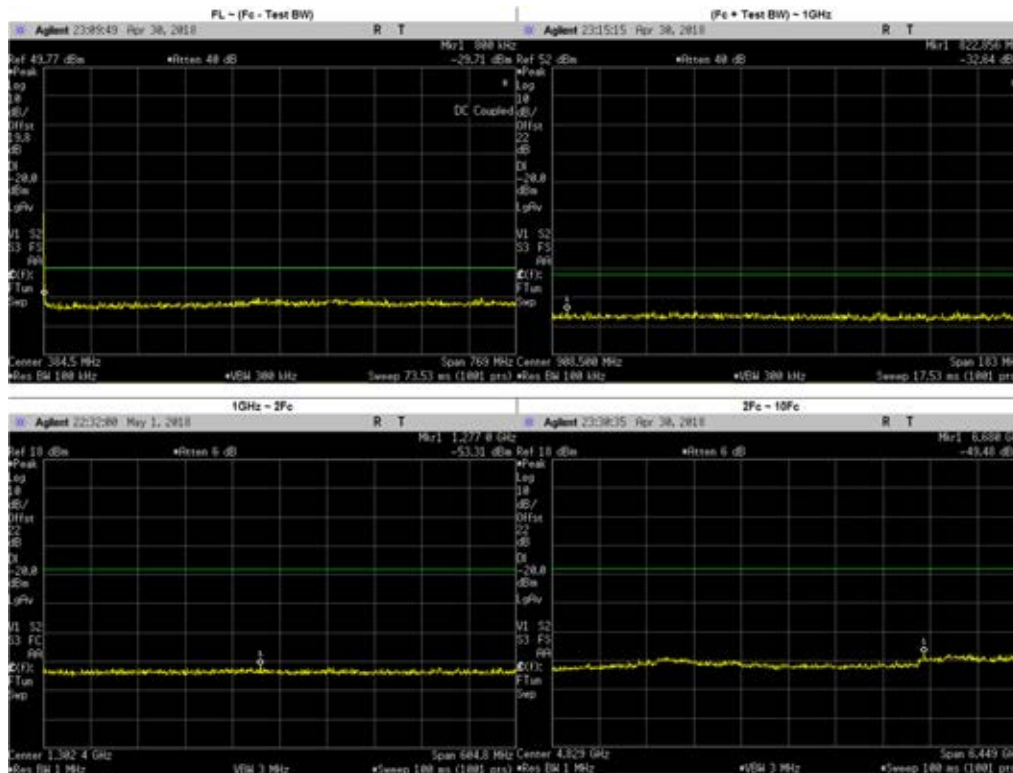

Frequency Range	Highest Spur Frequency (MHz)	Spurious Level (dBm)	Failing Limit (dBm)	Results
FL ~ (Fc - Test BW)	626.7367	-28.63	-20	PASS
(Fc + Test BW) ~ 1GHz	822.8560	-32.64	-20	PASS
1GHz ~ 2Fc	1277.0000	-53.31	-20	PASS
2Fc ~ 10Fc	6680.0000	-49.48	-20	PASS
	1609.8250	-55.41	-20	PASS
	2414.7380	-53.86	-20	PASS
	3219.6500	-51.73	-20	PASS
	4024.5620	-52.74	-20	PASS
	4829.4750	-53.82	-20	PASS
	5634.3870	-54.32	-20	PASS
	6439.3000	-53.80	-20	PASS
	7244.2120	-51.66	-20	PASS
8049.1250	-52.17	-20	PASS	

6.10.4. Test Limit

Table below summarized the power of any emission outside a licensee’s frequency block shall be attenuated below the transmitter power (P) by at least

Channel Spacing	Part 22	Part 24D	Part 74	Part 80	Part 90 (UHF, VHF, 800, 900)	Part 90 (700)
12.5kHz	43 + log ₁₀ (P) (-13 dBm)	43 + log ₁₀ (P) (-13 dBm)	43 + log ₁₀ (P) (-13 dBm)	Not Applicable	50 + log ₁₀ (P) (-20 dBm)	43 + log ₁₀ (P) (-13 dBm)
25kHz		Not Applicable		43 + log ₁₀ (P) (-13 dBm)	43 + log ₁₀ (P) (-13 dBm)	43 + log ₁₀ (P) (-13 dBm)

Channel Spacing	RSS 134	RSS 182	RSS 119 (UHF, VHF, 800, 900)	RSS 119 (700)
12.5kHz	43 + log ₁₀ (P) (-13 dBm)	Not Applicable	50 + log ₁₀ (P) (-20 dBm)	43 + log ₁₀ (P) (-13 dBm)
25kHz	Not Applicable	43 + log ₁₀ (P) (-13 dBm)	43 + log ₁₀ (P) (-13 dBm)	43 + log ₁₀ (P) (-13 dBm)

6.11. Radiated Spurious Emission

6.11.1. Test Setup

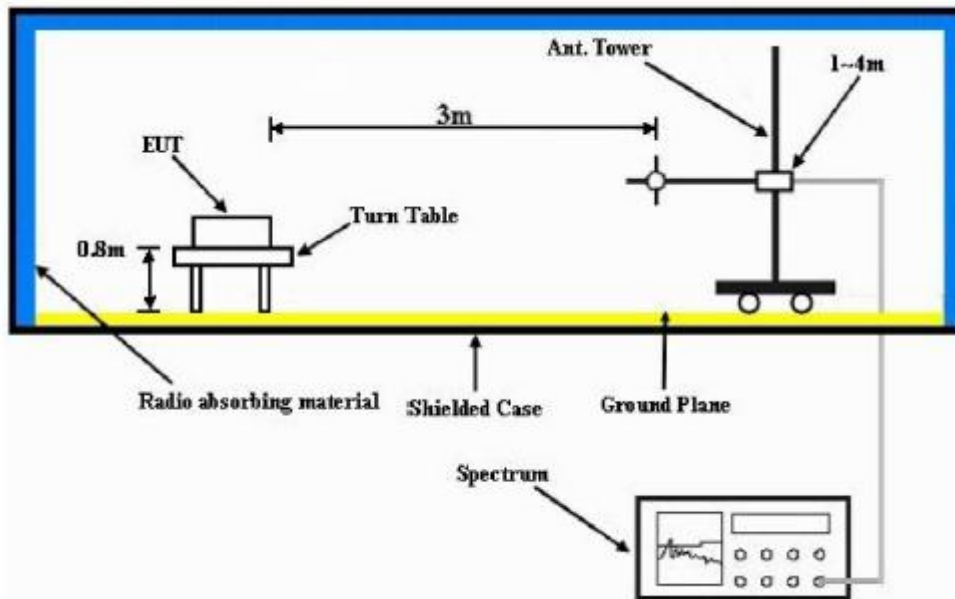

- 1) The Resolution Bandwidth for scanning Radiated Emission below 1 GHz is 100 kHz with Video Bandwidth = 300 kHz and Resolution Bandwidth for above 1 GHz is 1 MHz with Video Bandwidth = 3 MHz. Detector mode is positive peak.
- 2) In the semi- anechoic chamber, setup as illustrated above the DUT placed on the 0.8m height (for frequencies < 1GHz) and 1.5m (for frequencies > 1GHz) of Turn Table, rotated the table around 360 degrees to search the maximum radiation power and receiver antenna shall be rotated vertical and horizontal polarization and moved height from 1m to 4m to find the maximum polar radiated power. The “Read Value” is the spectrum reading the maximum power value.
- 3) The substitution antenna is substituted for DUT at the same position and signals generator (S.G) export the CW signal to the substitution antenna via a TX cable. The receiver antenna shall be rotated vertical and horizontal polarization and moved height from 1m to 4m to find the maximum radiation power. Record the power level of maximum radiation power from spectrum. So, the measured substitution value = Ref level of S.G + TX cables loss – Substituted Antenna Gain.
- 4) Final Radiated Spurious Emission = “Read Value” + Measured substitution value.

6.11.2. Test Result (Analog)

SAC Transmitter Radiated Emission:

Model Number: M37TXS9PW1AN S/N: 681P3A0078 SR:08878-EMC-00004
 Battery Part No: NA Accy Part No: 3466-HMN1079G-3,
 3466-HKN6163C-1, 254-HKN6170B-02, 1187-HKN6188B-1, 1187-PMHN4194A-1
 Test Mode: TX Analog
 762.012500 MHz 12.5 kHz 36.000 Watt(s) /Max Power

Frequency (MHz)	Limit	Horizontal Measured Emission Equiv Pwr Into Ideal Dipole (dBm)	Vertical Measured Emission Equiv Pwr Into ideal Dipole (dBm)
1424.0000	-13.0000	-56.1200 *	-54.7700 *
1440.4500	-13.0000	-56.4700 *	-53.8700 *
1524.0250	-13.0000	-51.2800 *	-54.7900 *
1769.4400	-13.0000	-46.5400 *	-55.5700 *
2286.0375	-13.0000	-56.0124 **	-54.5091 **
3048.0500	-13.0000	-47.1900 *	-46.3100 *
3810.0625	-13.0000	-52.0659 **	-50.8129 **
4572.0750	-13.0000	-51.3717 **	-50.9848 **
5334.0875	-13.0000	-48.9512 **	-47.8454 **
6096.1000	-13.0000	-46.3776 **	-45.5459 **
6858.1125	-13.0000	-44.5788 **	-43.0415 **
7620.1250	-13.0000	-43.3318 **	-43.6554 **

RADIATED SPURIOUS EMISSIONS

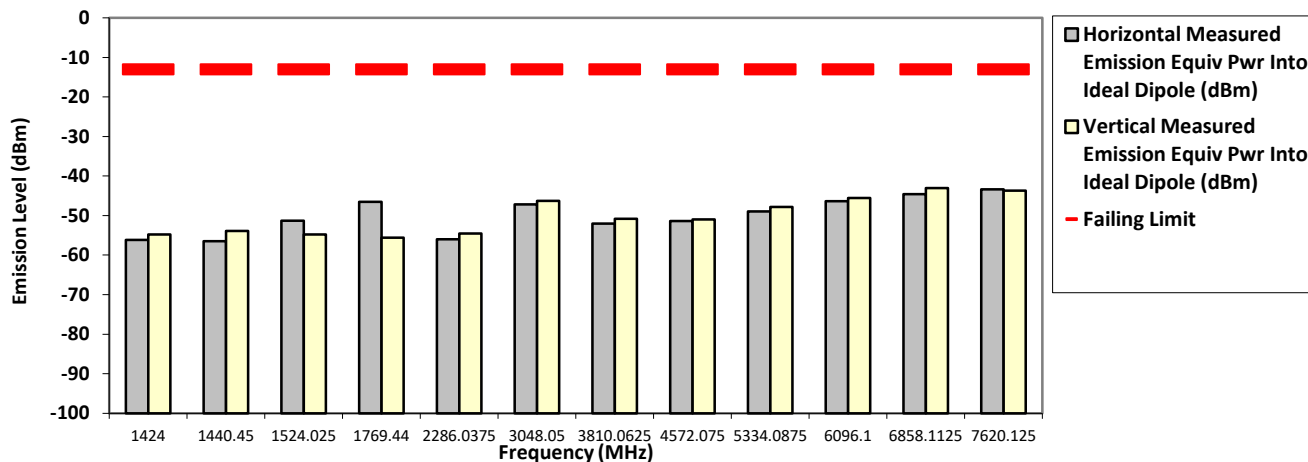

The data presented here was taken using the substitution method as found in the ANSI C63.26-2015 document.
 Motorola Penang EMC Lab - Test Performed by: Nazrin&Qawiman Sun, May 27, 2018

Remarks: ** Indicates the spurious emission could not be detected due to noise limitations or ambient.

*Pursuant to CFR 47 Part 2.1057 (c), emissions attenuated more than 20 dB below the permissible limit are not reported
 Temp(Deg): 22.3 Hum(%RH): 71.2

System MU: 5.01 dB

Remarks:

Passed Results	Marginal Results	Failed Results
----------------	------------------	----------------

SAC Transmitter Radiated Emission:

Model Number: M37TXS9PW1AN **S/N: 681P3A0078** **SR:08878-EMC-00004**
Battery Part No: NA **Accy Part No: 3466-HMN1079G-3,**
3466-HKN6163C-1, 254-HKN6170B-02, 1187-HKN6188B-1, 1187-PMHN4194A-1
Test Mode: TX Analog

762.012500 MHz **12.5 kHz** **1.000 Watt(s) /Low Power**

Frequency (MHz)	Limit	Horizontal Measured Emission Equip Pwr Into Ideal Dipole (dBm)	Vertical Measured Emission Equip Pwr Into ideal Dipole (dBm)
1424.3500	-13.0000	-56.2200 *	-54.5300 *
1456.2000	-13.0000	-55.7700 *	-54.1900 *
1524.0250	-13.0000	-52.5600 *	-53.6400 *
1769.7900	-13.0000	-55.0400 *	-50.6800 *
2286.0375	-13.0000	-57.0910 **	-57.7957 **
3048.0500	-13.0000	-54.2922 **	-51.7786 **
3810.0625	-13.0000	-52.2617 **	-51.6122 **
4572.0750	-13.0000	-51.4984 **	-50.7119 **
5334.0875	-13.0000	-49.2127 **	-49.7313 **
6096.1000	-13.0000	-44.0782 **	-44.9419 **
6858.1125	-13.0000	-41.8923 **	-43.9688 **
7620.1250	-13.0000	-44.4524 **	-43.6418 **

RADIATED SPURIOUS EMISSIONS

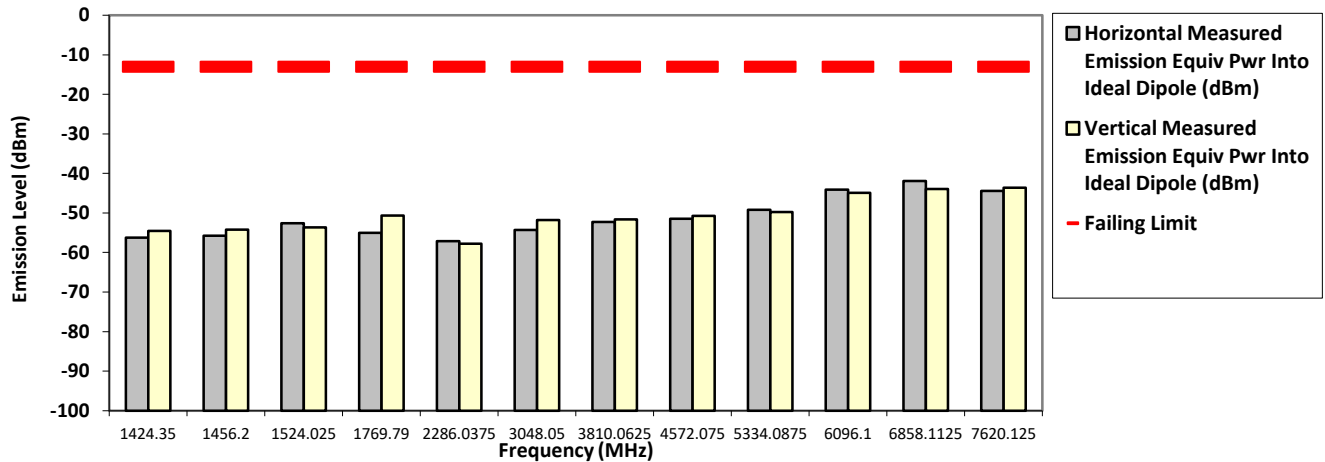

The data presented here was taken using the substitution method as found in the ANSI C63.26-2015 document.
 Motorola Penang EMC Lab - Test Performed by: Nazrin&Qawiman Sun, May 27, 2018

Remarks: ** Indicates the spurious emission could not be detected due to noise limitations or ambient.
 *Pursuant to CFR 47 Part 2.1057 (c), emissions attenuated more than 20 dB below the permissible limit are not reported
 Temp(Deg): 22.3 Hum(%RH): 71.2

System MU: 5.01 dB

Remarks: Passed Results Marginal Results Failed Results

SAC Transmitter Radiated Emission:

Model Number: M37TXS9PW1AN **S/N: 681P3A0078** **SR:08878-EMC-00004**
Battery Part No: NA **Accy Part No: 3466-HMN1079G-3,**
3466-HKN6163C-1, 254-HKN6170B-02, 1187-HKN6188B-1, 1187-PMHN4194A-1
Test Mode: TX Analog

764.012500 MHz **12.5 kHz** **36.000 Watt(s) /Max Power**

Frequency (MHz)	Limit	Horizontal Measured Emission Equip Pwr Into Ideal Dipole (dBm)	Vertical Measured Emission Equip Pwr Into ideal Dipole (dBm)
1424.0000	-13.0000	-54.8200 *	-44.3400 *
1528.0250	-13.0000	-49.6200 *	-48.2700 *
1768.7400	-13.0000	-55.1400 *	-55.5000 *
1770.8400	-13.0000	-55.8300 *	-45.5700 *
2292.0375	-13.0000	-56.8631 **	-55.4161 **
3056.0500	-13.0000	-46.6800 *	-44.6200 *
3820.0625	-13.0000	-51.2953 **	-52.0202 **
4584.0750	-13.0000	-51.8168 **	-51.3009 **
5348.0875	-13.0000	-49.4915 **	-48.0490 **
6112.1000	-13.0000	-45.0734 **	-45.7102 **
6876.1125	-13.0000	-43.7321 **	-42.3550 **
7640.1250	-13.0000	-38.5900 *	-39.2700 *

RADIATED SPURIOUS EMISSIONS

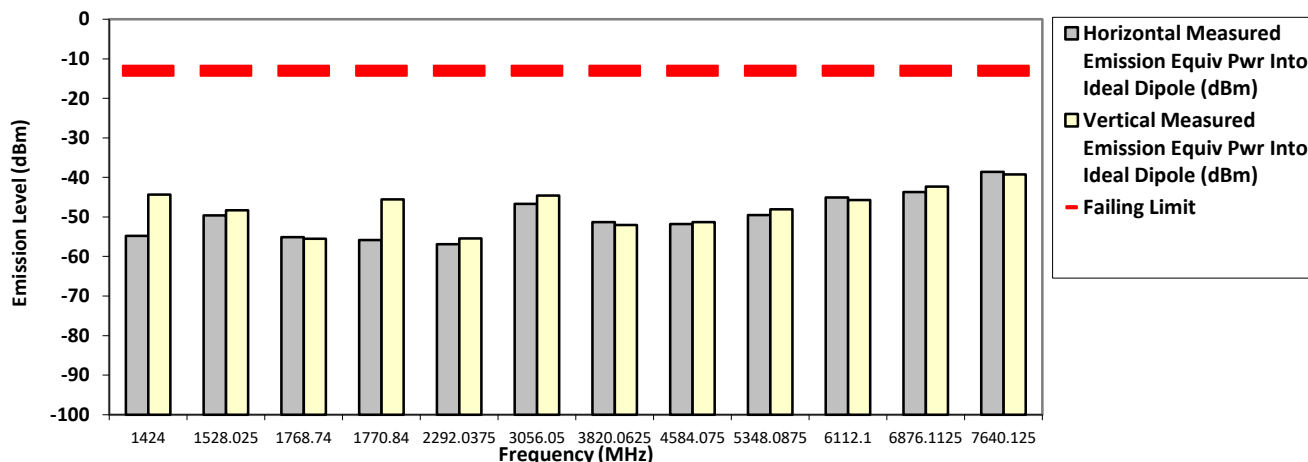

The data presented here was taken using the substitution method as found in the ANSI C63.26-2015 document.
 Motorola Penang EMC Lab - Test Performed by: Nazrin&Qawiman Thu, Apr 26, 2018

Remarks: ** Indicates the spurious emission could not be detected due to noise limitations or ambient.
 *Pursuant to CFR 47 Part 2.1057 (c), emissions attenuated more than 20 dB below the permissible limit are not reported
 Temp(Deg): 23.6 Hum(%RH): 70.8

System MU: 5.01 dB

Remarks: Passed Results Marginal Results Failed Results

SAC Transmitter Radiated Emission:

Model Number: M37TXS9PW1AN **S/N: 681P3A0078** **SR:08878-EMC-00004**
Battery Part No: NA **Accy Part No: 3466-HMN1079G-3,**
3466-HKN6163C-1, 254-HKN6170B-02, 1187-HKN6188B-1, 1187-PMHN4194A-1
Test Mode: TX Analog

764.012500 MHz **12.5 kHz** **1.000 Watt(s) /Low Power**

Frequency (MHz)	Limit	Horizontal Measured Emission Equiv Pwr Into Ideal Dipole (dBm)	Vertical Measured Emission Equiv Pwr Into ideal Dipole (dBm)
1424.7000	-13.0000	-55.1100 *	-49.5200 *
1528.0250	-13.0000	-47.4300 *	-44.5300 *
2292.0375	-13.0000	-57.7238 **	-59.1797 **
3056.0500	-13.0000	-56.2537 **	-55.5302 **
3820.0625	-13.0000	-53.3425 **	-53.3921 **
4584.0750	-13.0000	-51.2990 **	-51.5699 **
5348.0875	-13.0000	-48.5762 **	-48.6214 **
6112.1000	-13.0000	-46.1366 **	-46.3190 **
6876.1125	-13.0000	-43.6977 **	-42.2131 **
7640.1250	-13.0000	-45.2746 **	-44.9693 **

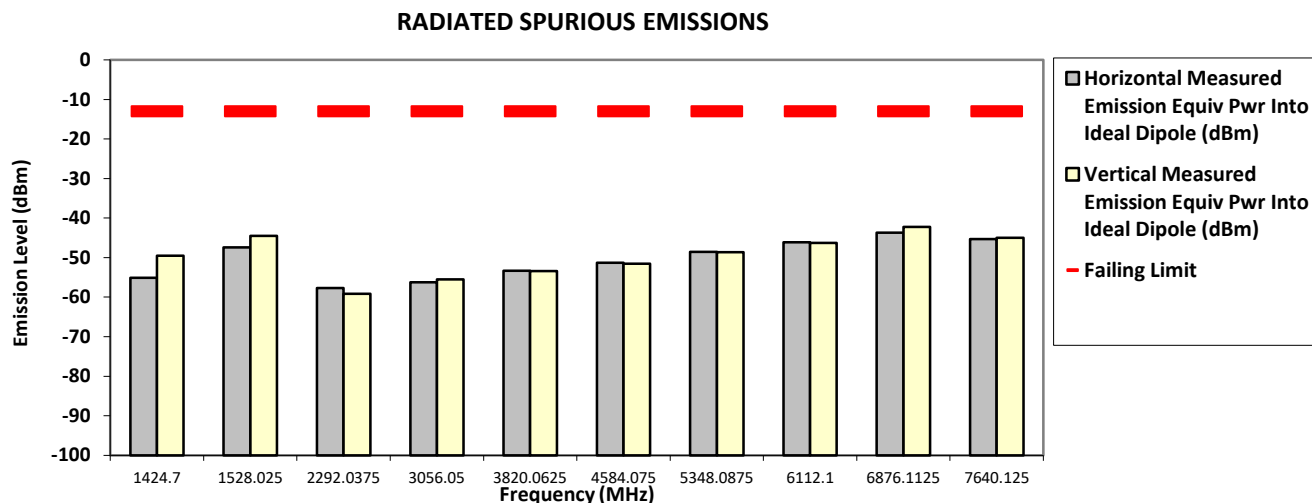

The data presented here was taken using the substitution method as found in the ANSI C63.26-2015 document.
 Motorola Penang EMC Lab - Test Performed by: Nazrin&Qawiman Thu, Apr 26, 2018

Remarks: ** Indicates the spurious emission could not be detected due to noise limitations or ambient.
 *Pursuant to CFR 47 Part 2.1057 (c), emissions attenuated more than 20 dB below the permissible limit are not reported
 Temp(Deg): 23.6 Hum(%RH): 70.8

System MU: 5.01 dB

Remarks:

Passed Results	Marginal Results	Failed Results
----------------	------------------	----------------

SAC Transmitter Radiated Emission:

Model Number: M37TXS9PW1AN **S/N: 681P3A0078** **SR:08878-EMC-00004**
Battery Part No: NA **Accy Part No: 3466-HMN1079G-3,**
3466-HKN6163C-1, 254-HKN6170B-02, 1187-HKN6188B-1, 1187-PMHN4194A-1
Test Mode: TX Analog
769.012500 MHz **12.5 kHz** **2.00 Watt(s) /Max Power**

Frequency (MHz)	Limit	Horizontal Measured Emission Equip Pwr Into Ideal Dipole (dBm)	Vertical Measured Emission Equip Pwr Into ideal Dipole (dBm)
1424.3500	-13.0000	-54.5300 *	-53.6700 *
1440.4500	-13.0000	-55.1600 *	-54.7100 *
1538.0250	-13.0000	-61.3688 **	-60.0595 **
2307.0375	-13.0000	-58.3759 **	-57.5049 **
3076.0500	-13.0000	-54.9689 **	-54.9232 **
3845.0625	-13.0000	-52.3789 **	-53.7361 **
4614.0750	-13.0000	-51.3669 **	-51.2260 **
5383.0875	-13.0000	-48.1940 **	-48.7992 **
6152.1000	-13.0000	-46.0465 **	-45.9202 **
6921.1125	-13.0000	-43.4131 **	-42.7331 **
7690.1250	-13.0000	-45.4895 **	-45.9802 **

RADIATED SPURIOUS EMISSIONS

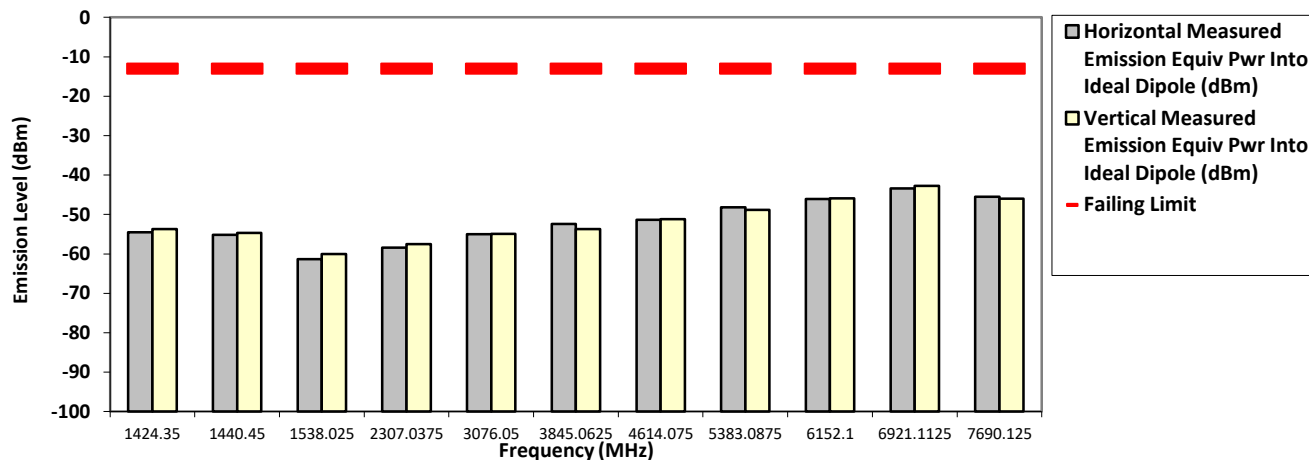

The data presented here was taken using the substitution method as found in the ANSI C63.26-2015 document.
 Motorola Penang EMC Lab - Test Performed by: Nazrin&Qawiman Mon, May 07, 2018

Remarks: ** Indicates the spurious emission could not be detected due to noise limitations or ambient.
 *Pursuant to CFR 47 Part 2.1057 (c), emissions attenuated more than 20 dB below the permissible limit are not reported
 Temp(Deg): 23.4 Hum(%RH): 70.9

System MU: 5.01 dB

Remarks: Passed Results Marginal Results Failed Results

SAC Transmitter Radiated Emission:

Model Number: M37TXS9PW1AN **S/N: 681P3A0078** **SR:08878-EMC-00004**
Battery Part No: NA **Accy Part No: 3466-HMN1079G-3,**
3466-HKN6163C-1, 254-HKN6170B-02, 1187-HKN6188B-1, 1187-PMHN4194A-1
Test Mode: TX Analog

769.087500 MHz **12.5 kHz** **36.000 Watt(s) /Max Power**

Frequency (MHz)	Limit	Horizontal Measured Emission Equip Pwr Into Ideal Dipole (dBm)	Vertical Measured Emission Equip Pwr Into ideal Dipole (dBm)
1424.0000	-13.0000	-54.6000 *	-44.4500 *
1538.1750	-13.0000	-52.3600 *	-46.0700 *
2307.2625	-13.0000	-55.6118 **	-54.8580 **
3076.3500	-13.0000	-46.7300 *	-44.1400 *
3845.4375	-13.0000	-51.1700 **	-52.7274 **
4614.5250	-13.0000	-51.1838 **	-50.9778 **
5383.6125	-13.0000	-48.7819 **	-48.7734 **
6152.7000	-13.0000	-46.1699 **	-45.6683 **
6921.7875	-13.0000	-42.5766 **	-43.8844 **
7690.8750	-13.0000	-43.7101 **	-43.3737 **

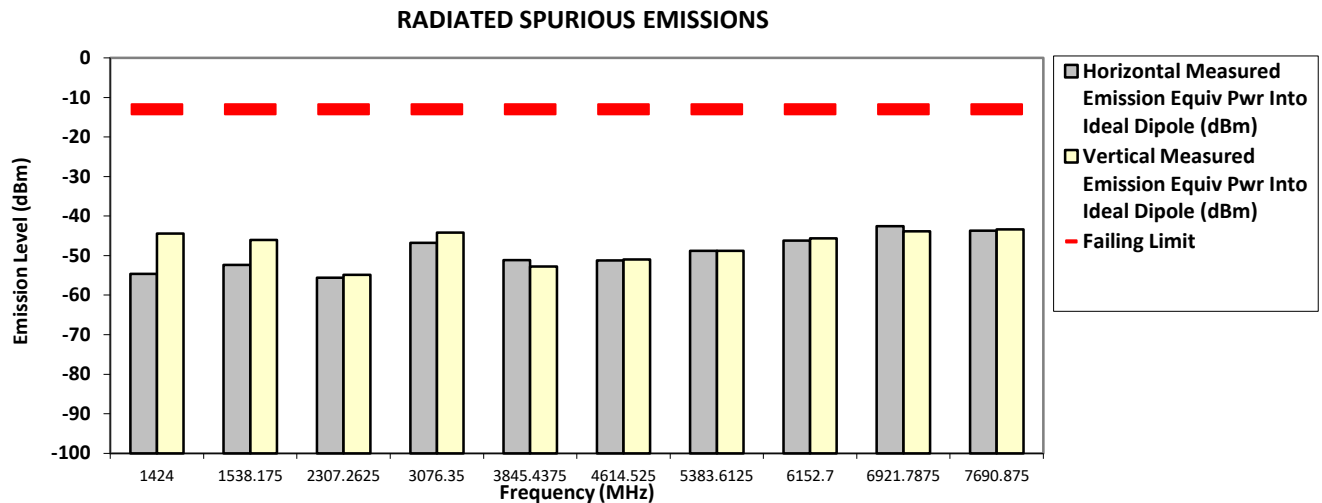

The data presented here was taken using the substitution method as found in the ANSI C63.26-2015 document.
 Motorola Penang EMC Lab - Test Performed by: Nazrin&Qawiman Fri, Apr 27, 2018

Remarks: ** Indicates the spurious emission could not be detected due to noise limitations or ambient.
 *Pursuant to CFR 47 Part 2.1057 (c), emissions attenuated more than 20 dB below the permissible limit are not reported
 Temp(Deg): 23.6 Hum(%RH): 70.8

System MU: 5.01 dB

Remarks: Passed Results Marginal Results Failed Results

SAC Transmitter Radiated Emission:

Model Number: M37TXS9PW1AN **S/N: 681P3A0078** **SR:08878-EMC-00004**
Battery Part No: NA **Accy Part No: 3466-HMN1079G-3,**
3466-HKN6163C-1, 254-HKN6170B-02, 1187-HKN6188B-1, 1187-PMHN4194A-1
Test Mode: TX Analog

769.087500 MHz **12.5 kHz** **1.000 Watt(s) /Low Power**

Frequency (MHz)	Limit	Horizontal Measured Emission Equiv Pwr Into Ideal Dipole (dBm)	Vertical Measured Emission Equiv Pwr Into ideal Dipole (dBm)
1538.1750	-13.0000	-61.9374 **	-61.8583 **
1769.0900	-13.0000	-39.1300 *	-37.1000 *
2307.2625	-13.0000	-58.7609 **	-58.1348 **
3076.3500	-13.0000	-55.5898 **	-54.1339 **
3845.4375	-13.0000	-52.9184 **	-53.2926 **
4614.5250	-13.0000	-51.2697 **	-51.8712 **
5383.6125	-13.0000	-48.8041 **	-49.5113 **
6152.7000	-13.0000	-46.1109 **	-45.0393 **
6921.7875	-13.0000	-44.7548 **	-43.6813 **
7690.8750	-13.0000	-45.3708 **	-45.0430 **

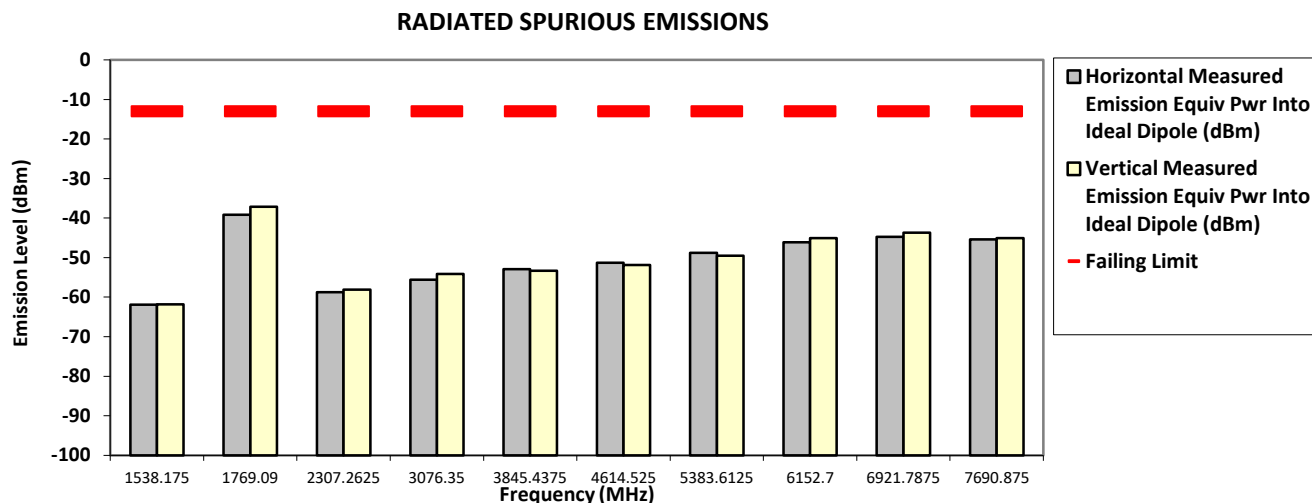

The data presented here was taken using the substitution method as found in the ANSI C63.26-2015 document.
 Motorola Penang EMC Lab - Test Performed by: Nazrin&Qawiman Fri, Apr 27, 2018

Remarks: ** Indicates the spurious emission could not be detected due to noise limitations or ambient.
 *Pursuant to CFR 47 Part 2.1057 (c), emissions attenuated more than 20 dB below the permissible limit are not reported
 Temp(Deg): 23.6 Hum(%RH): 70.8

System MU: 5.01 dB

Remarks: Passed Results Marginal Results Failed Results

SAC Transmitter Radiated Emission:

Model Number: M37TXS9PW1AN **S/N: 681P3A0078** **SR:08878-EMC-00004**
Battery Part No: NA **Accy Part No: 3466-HMN1079G-3,**
3466-HKN6163C-1, 254-HKN6170B-02, 1187-HKN6188B-1, 1187-PMHN4194A-1
Test Mode: TX Analog

774.887500 MHz **12.5 kHz** **36.000 Watt(s) /Max Power**

Frequency (MHz)	Limit	Horizontal Measured Emission Equip Pwr Into Ideal Dipole (dBm)	Vertical Measured Emission Equip Pwr Into ideal Dipole (dBm)
1424.0000	-13.0000	-54.7000 *	-43.5900 *
1536.3500	-13.0000	-54.7700 *	-46.4400 *
1549.7750	-13.0000	-58.3610 **	-57.7434 **
1770.1400	-13.0000	-51.0400 *	-48.3600 *
2324.6625	-13.0000	-54.8939 **	-55.2243 **
3099.5500	-13.0000	-47.2000 *	-44.3900 *
3874.4375	-13.0000	-52.3431 **	-52.1744 **
4649.3250	-13.0000	-50.6606 **	-51.0109 **
5424.2125	-13.0000	-47.9289 **	-48.4134 **
6199.1000	-13.0000	-45.4047 **	-45.5144 **
6973.9875	-13.0000	-43.4615 **	-45.0375 **
7748.8750	-13.0000	-36.3200 *	-34.7600 *

RADIATED SPURIOUS EMISSIONS

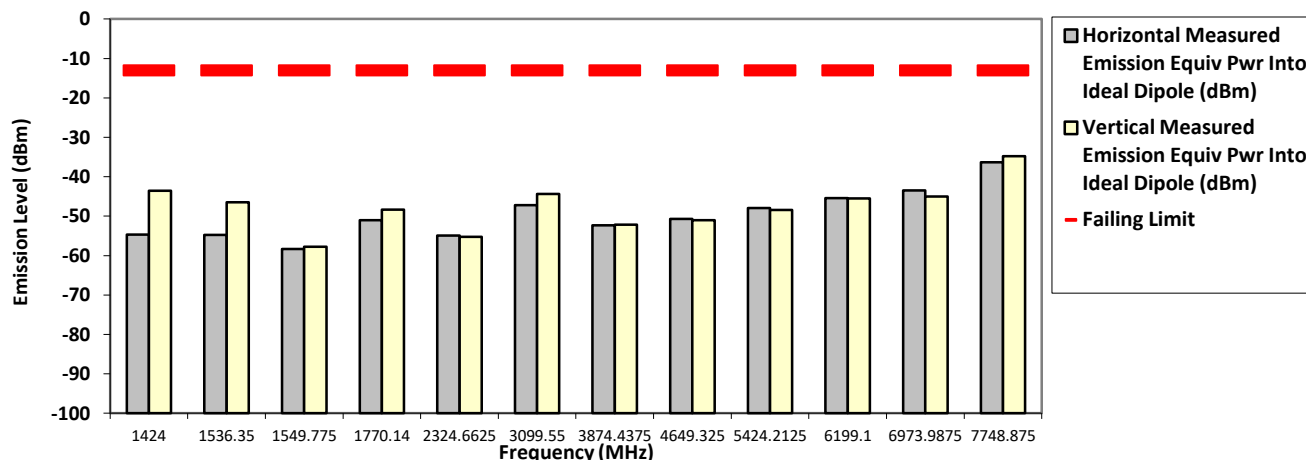

The data presented here was taken using the substitution method as found in the ANSI C63.26-2015 document.
 Motorola Penang EMC Lab - Test Performed by: Nazrin&Qawiman Fri, Apr 27, 2018

Remarks: ** Indicates the spurious emission could not be detected due to noise limitations or ambient.
 *Pursuant to CFR 47 Part 2.1057 (c), emissions attenuated more than 20 dB below the permissible limit are not reported
 Temp(Deg): 23.6 Hum(%RH): 70.8

System MU: 5.01 dB

Remarks: Passed Results Marginal Results Failed Results

SAC Transmitter Radiated Emission:

Model Number: M37TXS9PW1AN **S/N: 681P3A0078** **SR:08878-EMC-00004**
Battery Part No: NA **Accy Part No: 3466-HMN1079G-3,**
3466-HKN6163C-1, 254-HKN6170B-02, 1187-HKN6188B-1, 1187-PMHN4194A-1
Test Mode: TX Analog

774.887500 MHz **12.5 kHz** **1.000 Watt(s) /Low Power**

Frequency (MHz)	Limit	Horizontal Measured Emission Equiv Pwr Into Ideal Dipole (dBm)	Vertical Measured Emission Equiv Pwr Into ideal Dipole (dBm)
1549.7750	-13.0000	-61.8723 **	-62.4983 **
2324.6625	-13.0000	-56.4978 **	-57.5446 **
3099.5500	-13.0000	-54.8519 **	-54.9206 **
3874.4375	-13.0000	-52.8132 **	-53.0571 **
4649.3250	-13.0000	-50.9254 **	-51.1833 **
5424.2125	-13.0000	-49.1347 **	-49.4255 **
6199.1000	-13.0000	-45.7082 **	-46.4288 **
6973.9875	-13.0000	-43.9314 **	-43.9974 **
7748.8750	-13.0000	-44.6813 **	-45.6855 **

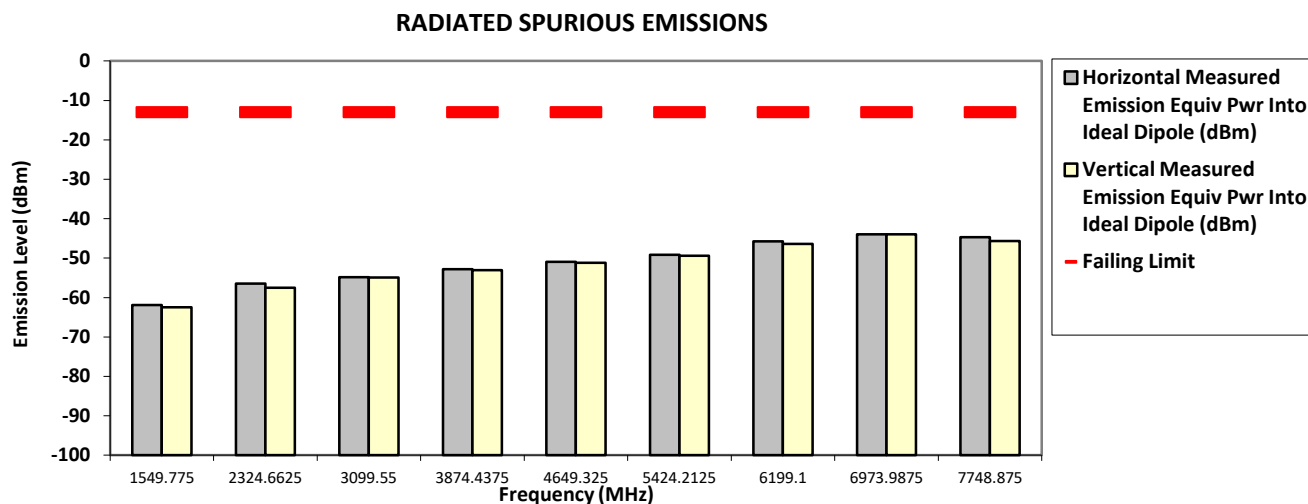

The data presented here was taken using the substitution method as found in the ANSI C63.26-2015 document.
 Motorola Penang EMC Lab - Test Performed by: Nazrin&Qawiman Fri, Apr 27, 2018

Remarks: ** Indicates the spurious emission could not be detected due to noise limitations or ambient.
 *Pursuant to CFR 47 Part 2.1057 (c), emissions attenuated more than 20 dB below the permissible limit are not reported
 Temp(Deg): 23.6 Hum(%RH): 70.8

System MU: 5.01 dB

Remarks: Passed Results Marginal Results Failed Results

SAC Transmitter Radiated Emission:

Model Number: M37TXS9PW1AN **S/N: 681P3A0078** **SR:08878-EMC-00004**
Battery Part No: NA **Accy Part No: 3466-HMN1079G-3,**
3466-HKN6163C-1, 254-HKN6170B-02, 1187-HKN6188B-1, 1187-PMHN4194A-1
Test Mode: TX Analog

792.012500 MHz **12.5 kHz** **36.000 Watt(s) /Max Power**

Frequency (MHz)	Limit	Horizontal Measured Emission Equip Pwr Into Ideal Dipole (dBm)	Vertical Measured Emission Equip Pwr Into ideal Dipole (dBm)
1424.0000	-13.0000	-56.0600 *	-54.9900 *
1536.0000	-13.0000	-54.0900 *	-53.9500 *
1584.0250	-13.0000	-55.5900 *	-53.9000 *
1769.4400	-13.0000	-55.2900 *	-55.6500 *
2376.0375	-13.0000	-50.8800 *	-47.4600 *
3168.0500	-13.0000	-42.4700 *	-41.1500 *
3960.0625	-13.0000	-52.9961 **	-51.9525 **
4752.0750	-13.0000	-51.0141 **	-50.2569 **
5544.0875	-13.0000	-48.1044 **	-48.6848 **
6336.1000	-13.0000	-45.2105 **	-45.1411 **
7128.1125	-13.0000	-48.2385 **	-47.2149 **
7920.1250	-13.0000	-35.2800 *	-33.3000 *

RADIATED SPURIOUS EMISSIONS

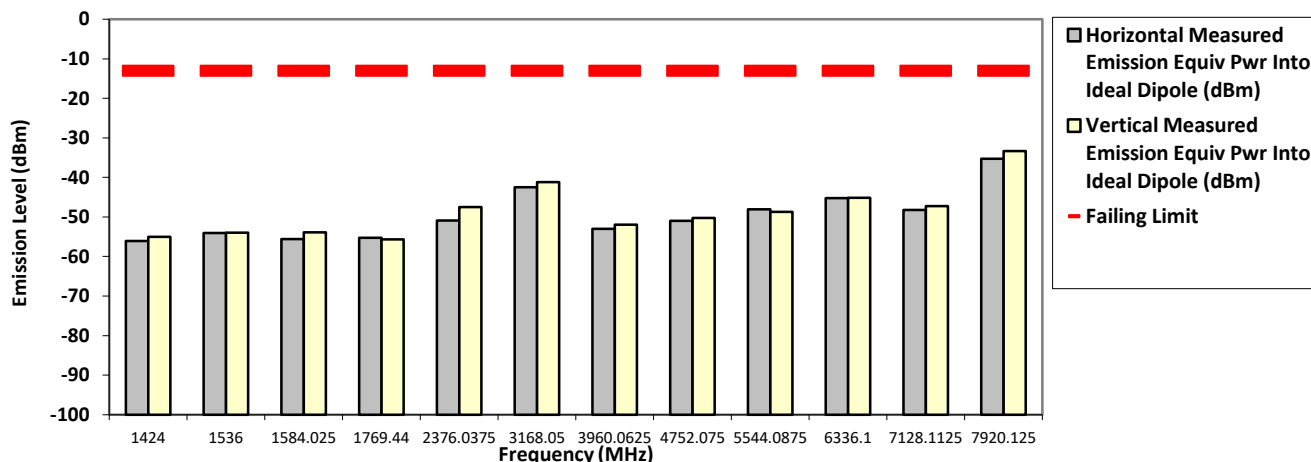

The data presented here was taken using the substitution method as found in the ANSI C63.26-2015 document.
 Motorola Penang EMC Lab - Test Performed by: Nazrin&Qawiman Sun, May 27, 2018

Remarks: ** Indicates the spurious emission could not be detected due to noise limitations or ambient.
 *Pursuant to CFR 47 Part 2.1057 (c), emissions attenuated more than 20 dB below the permissible limit are not reported
 Temp(Deg): 22.3 Hum(%RH): 71.2

System MU: 5.01 dB

Remarks: Passed Results Marginal Results Failed Results

SAC Transmitter Radiated Emission:

Model Number: M37TXS9PW1AN

S/N: 681P3A0078

SR:08878-EMC-00004

Battery Part No: NA

Accy Part No: 3466-HMN1079G-3,

3466-HKN6163C-1, 254-HKN6170B-02, 1187-HKN6188B-1, 1187-PMHN4194A-1

Test Mode: TX Analog

792.012500 MHz

12.5 kHz

1.000 Watt(s) /Low Power

Frequency (MHz)	Limit	Horizontal Measured Emission Equip Pwr Into Ideal Dipole (dBm)	Vertical Measured Emission Equip Pwr Into ideal Dipole (dBm)
1424.0000	-13.0000	-56.6200 *	-54.7800 *
1440.1000	-13.0000	-55.5500 *	-53.5300 *
1456.2000	-13.0000	-55.3700 *	-53.8500 *
1584.0250	-13.0000	-55.4200 *	-53.7200 *
1769.4400	-13.0000	-37.4000 *	-42.3500 *
2376.0375	-13.0000	-55.8473 **	-55.2602 **
3168.0500	-13.0000	-47.4800 *	-45.5000 *
3960.0625	-13.0000	-52.1032 **	-52.2182 **
4752.0750	-13.0000	-49.8046 **	-50.7474 **
5544.0875	-13.0000	-49.3715 **	-48.2831 **
6336.1000	-13.0000	-46.3228 **	-45.3190 **
7128.1125	-13.0000	-47.8202 **	-47.6844 **
7920.1250	-13.0000	-45.9035 **	-45.3527 **

RADIATED SPURIOUS EMISSIONS

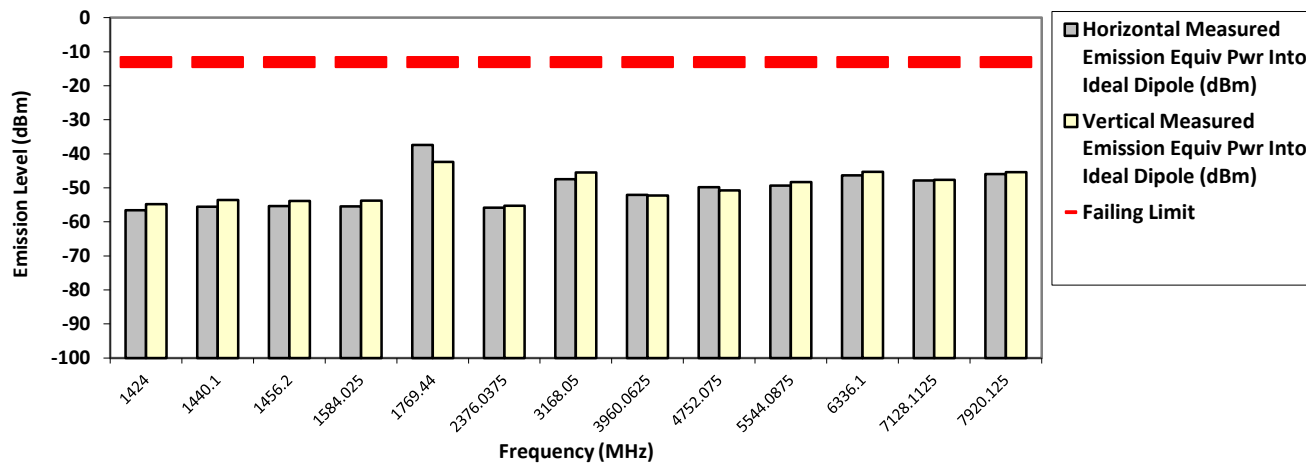

The data presented here was taken using the substitution method as found in the ANSI C63.26-2015 document.

Motorola Penang EMC Lab - Test Performed by: Nazrin&Qawiman

Sun, May 27, 2018

Remarks: ** Indicates the spurious emission could not be detected due to noise limitations or ambient.

*Pursuant to CFR 47 Part 2.1057 (c), emissions attenuated more than 20 dB below the permissible limit are not reported
 Temp(Deg): 22.3 Hum(%RH): 71.2

System MU: 5.01 dB

Remarks:

Passed Results	Marginal Results	Failed Results
----------------	------------------	----------------

SAC Transmitter Radiated Emission:

Model Number: M37TXS9PW1AN **S/N: 681P3A0078** **SR:08878-EMC-00004**
Battery Part No: NA **Accy Part No: 3466-HMN1079G-3,**
3466-HKN6163C-1, 254-HKN6170B-02, 1187-HKN6188B-1, 1187-PMHN4194A-1
Test Mode: TX Analog

799.087500 MHz **12.5 kHz** **36.000 Watt(s) /Max Power**

Frequency (MHz)	Limit	Horizontal Measured Emission Equip Pwr Into Ideal Dipole (dBm)	Vertical Measured Emission Equip Pwr Into ideal Dipole (dBm)
1424.3500	-13.0000	-55.0300 *	-52.7200 *
1456.2000	-13.0000	-54.4100 *	-42.3600 *
1598.1750	-13.0000	-59.2258 **	-58.2026 **
2397.2625	-13.0000	-48.0000 *	-47.0000 *
3196.3500	-13.0000	-43.5500 *	-39.2200 *
3995.4375	-13.0000	-51.6526 **	-52.7544 **
4794.5250	-13.0000	-48.5783 **	-47.5260 **
5593.6125	-13.0000	-48.4246 **	-48.6132 **
6392.7000	-13.0000	-46.3157 **	-44.2398 **
7191.7875	-13.0000	-44.7888 **	-42.6122 **
7990.8750	-13.0000	-33.1600 *	-29.2400

RADIATED SPURIOUS EMISSIONS

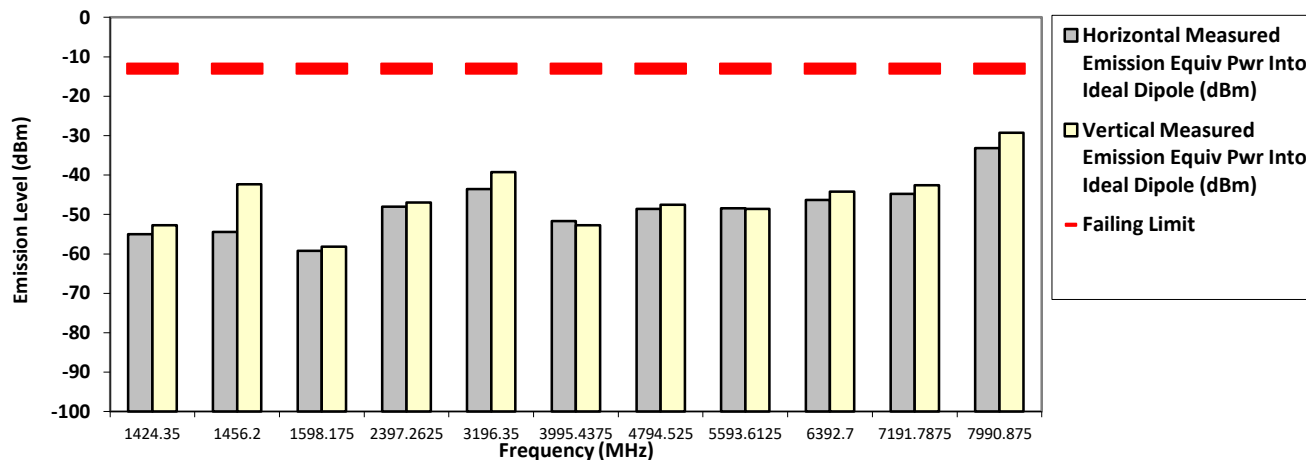

The data presented here was taken using the substitution method as found in the ANSI C63.26-2015 document.
 Motorola Penang EMC Lab - Test Performed by: Nazrin&Qawiman Fri, Apr 27, 2018

Remarks: ** Indicates the spurious emission could not be detected due to noise limitations or ambient.
 *Pursuant to CFR 47 Part 2.1057 (c), emissions attenuated more than 20 dB below the permissible limit are not reported
 Temp(Deg): 23.6 Hum(%RH): 70.8

System MU: 5.01 dB

Remarks: Passed Results Marginal Results Failed Results

SAC Transmitter Radiated Emission:

Model Number: M37TXS9PW1AN **S/N: 681P3A0078** **SR:08878-EMC-00004**
Battery Part No: NA **Accy Part No: 3466-HMN1079G-3,**
3466-HKN6163C-1, 254-HKN6170B-02, 1187-HKN6188B-1, 1187-PMHN4194A-1
Test Mode: TX Analog

799.087500 MHz **12.5 kHz** **1.000 Watt(s) /Low Power**

Frequency (MHz)	Limit	Horizontal Measured Emission Equip Pwr Into Ideal Dipole (dBm)	Vertical Measured Emission Equip Pwr Into ideal Dipole (dBm)
1440.0500	-13.0000	-49.2700 *	-42.7500 *
1598.1750	-13.0000	-60.9919 **	-60.9690 **
1769.4400	-13.0000	-42.2300 *	-39.3100 *
2397.2625	-13.0000	-57.5962 **	-58.9120 **
3196.3500	-13.0000	-54.4234 **	-54.1022 **
3995.4375	-13.0000	-53.2351 **	-52.3051 **
4794.5250	-13.0000	-50.5278 **	-50.5521 **
5593.6125	-13.0000	-48.1519 **	-47.8418 **
6392.7000	-13.0000	-46.2803 **	-46.0821 **
7191.7875	-13.0000	-46.7571 **	-46.9555 **
7990.8750	-13.0000	-45.7276 **	-45.4653 **

RADIATED SPURIOUS EMISSIONS

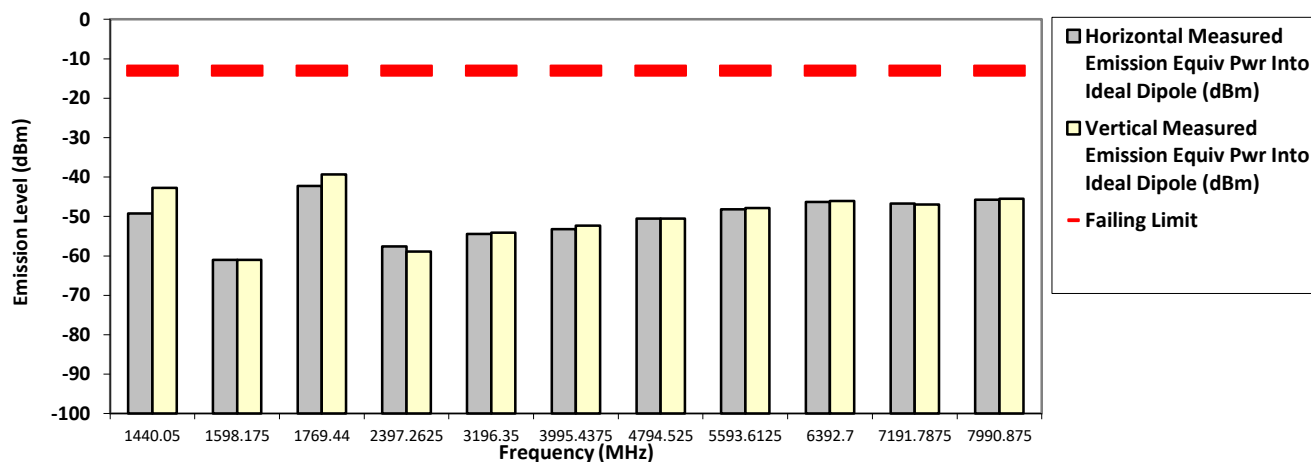

The data presented here was taken using the substitution method as found in the ANSI C63.26-2015 document.
 Motorola Penang EMC Lab - Test Performed by: Nazrin&Qawiman Fri, Apr 27, 2018

Remarks: ** Indicates the spurious emission could not be detected due to noise limitations or ambient.
 *Pursuant to CFR 47 Part 2.1057 (c), emissions attenuated more than 20 dB below the permissible limit are not reported
 Temp(Deg): 23.6 Hum(%RH): 70.8

System MU: 5.01 dB

Remarks:

Passed Results	Marginal Results	Failed Results
----------------	------------------	----------------

SAC Transmitter Radiated Emission:

Model Number: M37TXS9PW1AN **S/N: 681P3A0078** **SR:08878-EMC-00004**
Battery Part No: NA **Accy Part No: 3466-HMN1079G-3,**
3466-HKN6163C-1, 254-HKN6170B-02, 1187-HKN6188B-1, 1187-PMHN4194A-1
Test Mode: TX Analog

804.912500 MHz **12.5 kHz** **36.000 Watt(s) /Max Power**

Frequency (MHz)	Limit	Horizontal Measured Emission Equip Pwr Into Ideal Dipole (dBm)	Vertical Measured Emission Equip Pwr Into ideal Dipole (dBm)
1408.1800	-13.0000	-56.0200 *	-40.9500 *
1609.8250	-13.0000	-60.9250 **	-60.0709 **
1768.9600	-13.0000	-45.2300 *	-41.3800 *
2414.7375	-13.0000	-46.6700 *	-44.7500 *
3219.6500	-13.0000	-43.0000 *	-39.5300 *
4024.5625	-13.0000	-51.8004 **	-48.9926 **
4829.4750	-13.0000	-47.3362 **	-46.4969 **
5634.3875	-13.0000	-48.7814 **	-49.1430 **
6439.3000	-13.0000	-45.3753 **	-44.1076 **
7244.2125	-13.0000	-37.4300 *	-37.6500 *
8049.1250	-13.0000	-31.5000	-28.1700

RADIATED SPURIOUS EMISSIONS

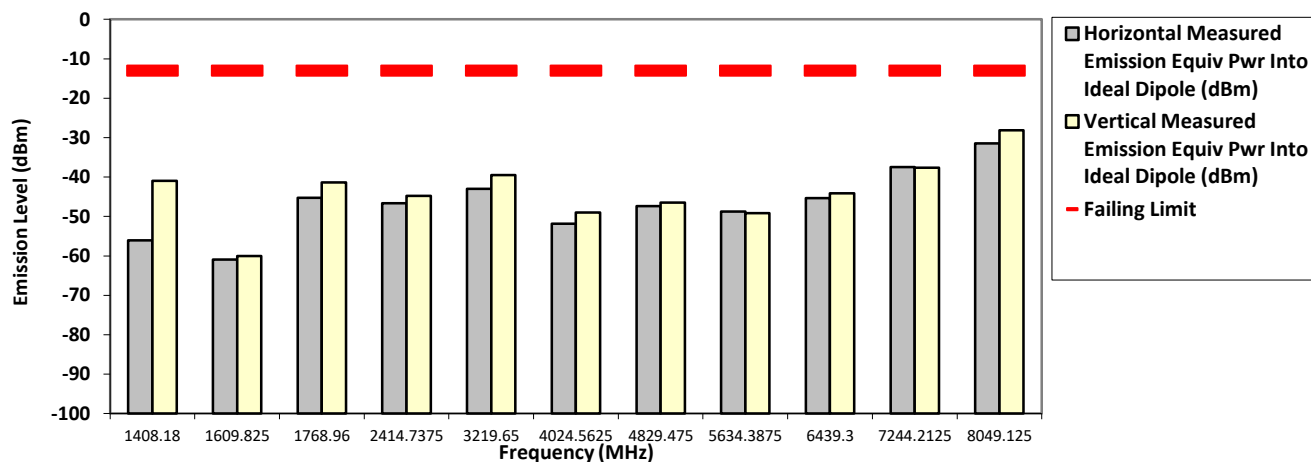

The data presented here was taken using the substitution method as found in the ANSI C63.26-2015 document.
 Motorola Penang EMC Lab - Test Performed by: Nazrin&Qawiman Fri, Apr 27, 2018

Remarks: ** Indicates the spurious emission could not be detected due to noise limitations or ambient.
 *Pursuant to CFR 47 Part 2.1057 (c), emissions attenuated more than 20 dB below the permissible limit are not reported
 Temp(Deg): 23.6 Hum(%RH): 70.8

System MU: 5.01 dB

Remarks: Passed Results Marginal Results Failed Results

SAC Transmitter Radiated Emission:

Model Number: M37TXS9PW1AN **S/N: 681P3A0078** **SR:08878-EMC-00004**
Battery Part No: NA **Accy Part No: 3466-HMN1079G-3,**
3466-HKN6163C-1, 254-HKN6170B-02, 1187-HKN6188B-1, 1187-PMHN4194A-1
Test Mode: TX Analog

804.912500 MHz **12.5 kHz** **1.000 Watt(s) /Low Power**

Frequency (MHz)	Limit	Horizontal Measured Emission Equiv Pwr Into Ideal Dipole (dBm)	Vertical Measured Emission Equiv Pwr Into ideal Dipole (dBm)
1424.5800	-13.0000	-55.1000 *	-53.0500 *
1609.8250	-13.0000	-61.0234 **	-61.2928 **
1768.8600	-13.0000	-52.3100 *	-45.5600 *
2414.7375	-13.0000	-58.6782 **	-58.0670 **
3219.6500	-13.0000	-52.7303 **	-54.3056 **
4024.5625	-13.0000	-53.0047 **	-53.4867 **
4829.4750	-13.0000	-50.0483 **	-51.0167 **
5634.3875	-13.0000	-48.4733 **	-49.0598 **
6439.3000	-13.0000	-46.1715 **	-46.4066 **
7244.2125	-13.0000	-45.2190 **	-43.9444 **
8049.1250	-13.0000	-45.7437 **	-45.9297 **

RADIATED SPURIOUS EMISSIONS

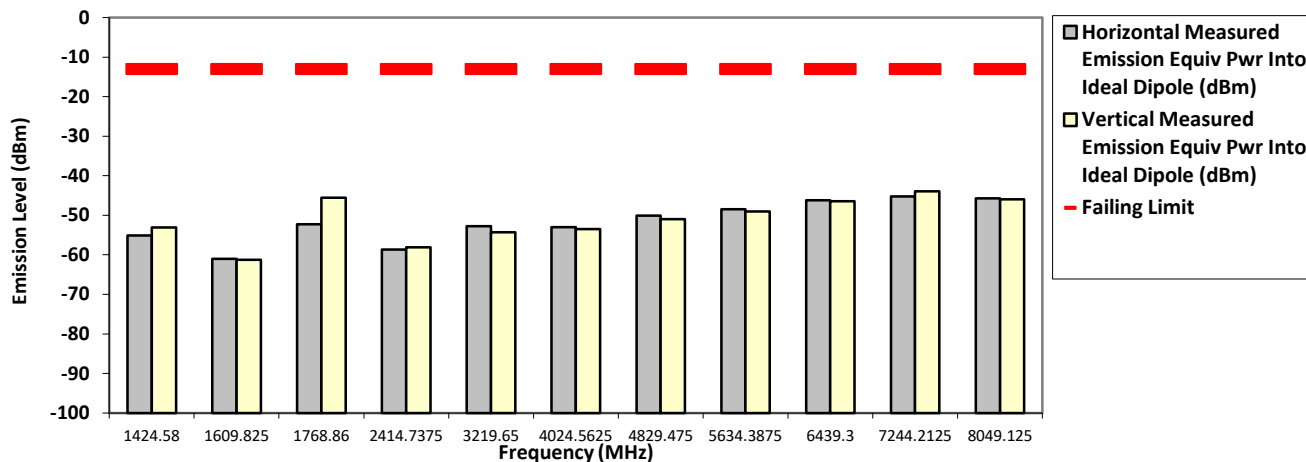

The data presented here was taken using the substitution method as found in the ANSI C63.26-2015 document.
 Motorola Penang EMC Lab - Test Performed by: Nazrin&Qawiman Fri, Apr 27, 2018

Remarks: ** Indicates the spurious emission could not be detected due to noise limitations or ambient.
 *Pursuant to CFR 47 Part 2.1057 (c), emissions attenuated more than 20 dB below the permissible limit are not reported
 Temp(Deg): 23.6 Hum(%RH): 70.8

System MU: 5.01 dB

Remarks: Passed Results Marginal Results Failed Results

6.11.3. Test Result (Analog)

SAC Transmitter Radiated Emission:

Model Number: M37TXS9PW1AN S/N: 681P3A0078 SR:08878-EMC-00004

Battery Part No: NA Accy Part No: 3466-HMN1079G-3,
 3466-HKN6163C-1, 254-HKN6170B-02, 1187-HKN6188B-1, 1187-PMHN4194A-1

Test Mode: TX APCO Digital C4FM

762.012500 MHz 12.5 kHz 36.000 Watt(s) /Max Power

Frequency (MHz)	Limit	Horizontal Measured Emission Equiv Pwr Into Ideal Dipole (dBm)	Vertical Measured Emission Equiv Pwr Into ideal Dipole (dBm)
1424.3500	-13.0000	-55.3700 *	-55.0700 *
1440.1000	-13.0000	-56.2500 *	-54.0200 *
1455.8500	-13.0000	-56.0600 *	-54.4300 *
1524.0250	-13.0000	-51.6300 *	-54.1800 *
2286.0375	-13.0000	-55.4838 **	-55.0492 **
3048.0500	-13.0000	-46.9700 *	-45.0900 *
3810.0625	-13.0000	-52.0262 **	-50.2833 **
4572.0750	-13.0000	-51.0036 **	-50.6264 **
5334.0875	-13.0000	-49.2704 **	-48.7590 **
6096.1000	-13.0000	-45.4598 **	-44.8360 **
6858.1125	-13.0000	-44.1517 **	-44.1975 **
7620.1250	-13.0000	-44.8906 **	-45.1757 **

RADIATED SPURIOUS EMISSIONS

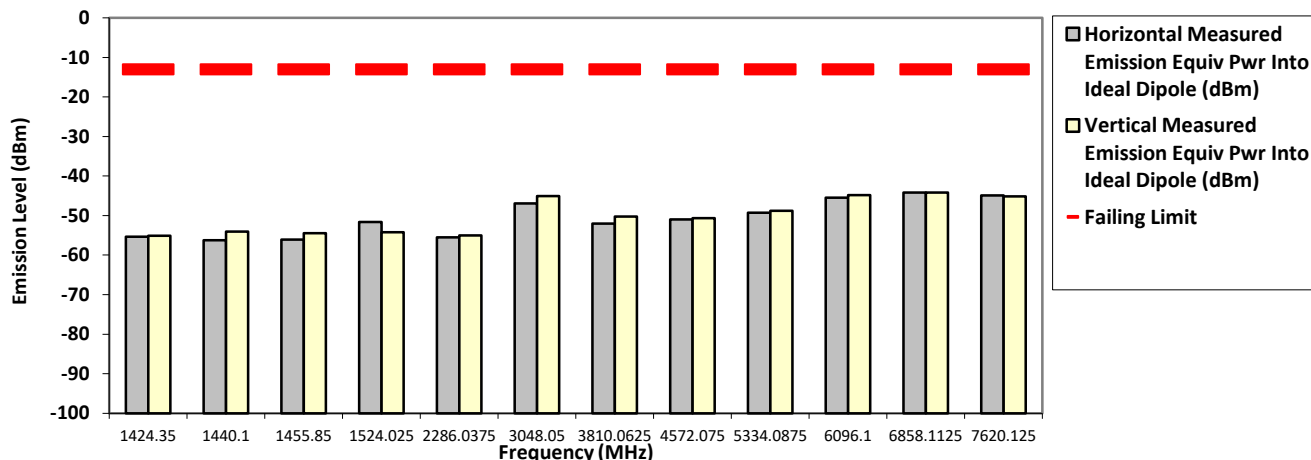

The data presented here was taken using the substitution method as found in the ANSI C63.26-2015 document.
 Motorola Penang EMC Lab - Test Performed by: Nazrin&Qawiman Mon, May 07, 2018

Remarks: ** Indicates the spurious emission could not be detected due to noise limitations or ambient.
 *Pursuant to CFR 47 Part 2.1057 (c), emissions attenuated more than 20 dB below the permissible limit are not reported
 Temp(Deg): 23.4 Hum(%RH): 70.9

System MU: 5.01 dB

Remarks:

Passed Results	Marginal Results	Failed Results
----------------	------------------	----------------

SAC Transmitter Radiated Emission:

Model Number: M37TXS9PW1AN **S/N: 681P3A0078** **SR:08878-EMC-00004**
Battery Part No: NA **Accy Part No: 3466-HMN1079G-3,**
3466-HKN6163C-1, 254-HKN6170B-02, 1187-HKN6188B-1, 1187-PMHN4194A-1
Test Mode: TX APCO Digital C4FM

762.012500 MHz 12.5 kHz 1.000 Watt(s) /Low Power

Frequency (MHz)	Limit	Horizontal Measured Emission Equiv Pwr Into Ideal Dipole (dBm)	Vertical Measured Emission Equiv Pwr Into ideal Dipole (dBm)
1424.0000	-13.0000	-54.9500 *	-55.1400 *
1456.2000	-13.0000	-54.8100 *	-55.3700 *
1520.2500	-13.0000	-55.6200 *	-54.3300 *
1524.0250	-13.0000	-60.5410 **	-58.8548 **
2286.0375	-13.0000	-58.0707 **	-57.6987 **
3048.0500	-13.0000	-54.9417 **	-54.6636 **
3810.0625	-13.0000	-52.2115 **	-53.6038 **
4572.0750	-13.0000	-51.8927 **	-50.2540 **
5334.0875	-13.0000	-49.5543 **	-49.4212 **
6096.1000	-13.0000	-45.9632 **	-45.6228 **
6858.1125	-13.0000	-44.3246 **	-42.7391 **
7620.1250	-13.0000	-44.5373 **	-45.4330 **

RADIATED SPURIOUS EMISSIONS

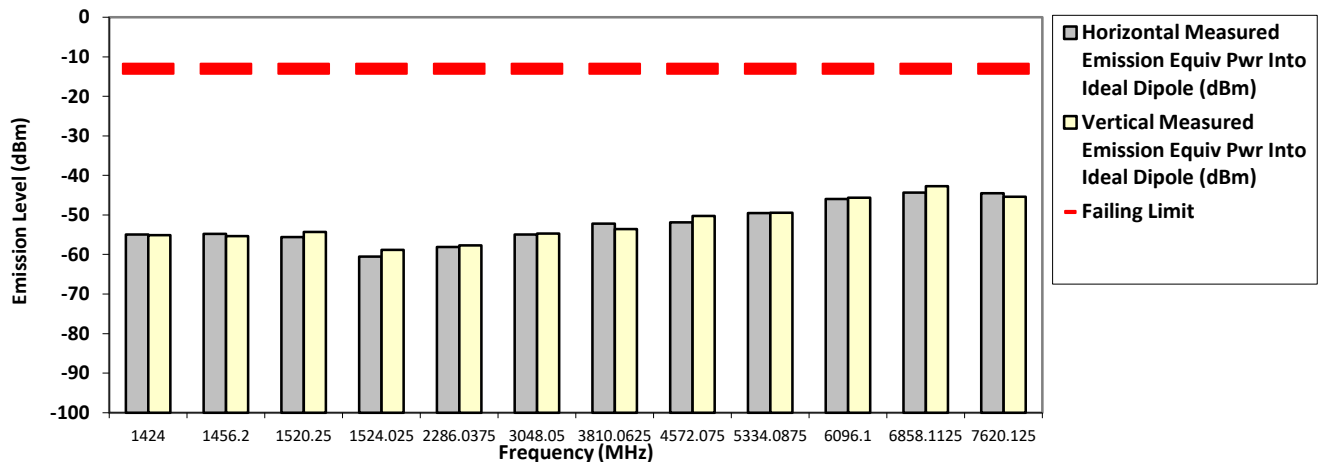

The data presented here was taken using the substitution method as found in the ANSI C63.26-2015 document.
 Motorola Penang EMC Lab - Test Performed by: Nazrin&Qawiman Mon, May 07, 2018

Remarks: ** Indicates the spurious emission could not be detected due to noise limitations or ambient.
 *Pursuant to CFR 47 Part 2.1057 (c), emissions attenuated more than 20 dB below the permissible limit are not reported
 Temp(Deg): 23.4 Hum(%RH): 70.9

System MU: 5.01 dB

Remarks: Passed Results Marginal Results Failed Results

SAC Transmitter Radiated Emission:

Model Number: M37TXS9PW1AN **S/N: 681P3A0078** **SR:08878-EMC-00004**
Battery Part No: NA **Accy Part No: 3466-HMN1079G-3,**
3466-HKN6163C-1, 254-HKN6170B-02, 1187-HKN6188B-1, 1187-PMHN4194A-1
Test Mode: TX APCO Digital C4FM

764.012500 MHz **12.5 kHz** **36.000 Watt(s) /Max Power**

Frequency (MHz)	Limit	Horizontal Measured Emission Equip Pwr Into Ideal Dipole (dBm)	Vertical Measured Emission Equip Pwr Into ideal Dipole (dBm)
1424.0000	-13.0000	-53.3500 *	-51.4300 *
1440.0000	-13.0000	-48.5100 *	-41.7400 *
1528.0250	-13.0000	-52.3100 *	-52.8000 *
1769.7900	-13.0000	-55.5000 *	-54.3400 *
2292.0375	-13.0000	-55.0314 **	-55.1417 **
3056.0500	-13.0000	-47.7500 *	-42.6900 *
3820.0625	-13.0000	-51.9364 **	-52.2650 **
4584.0750	-13.0000	-51.0056 **	-50.8968 **
5348.0875	-13.0000	-48.9218 **	-48.8063 **
6112.1000	-13.0000	-45.8723 **	-43.8569 **
6876.1125	-13.0000	-44.1070 **	-43.4293 **
7640.1250	-13.0000	-38.7000 *	-40.1400 *

RADIATED SPURIOUS EMISSIONS

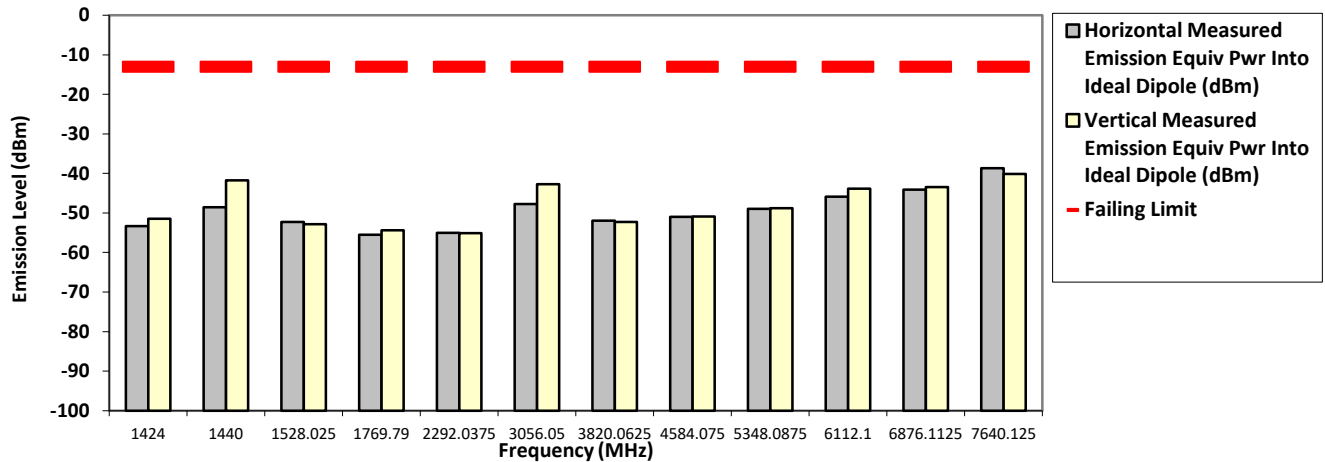

The data presented here was taken using the substitution method as found in the ANSI C63.26-2015 document.
 Motorola Penang EMC Lab - Test Performed by: Nazrin&Qawiman Sun, Apr 29, 2018

Remarks: ** Indicates the spurious emission could not be detected due to noise limitations or ambient.
 *Pursuant to CFR 47 Part 2.1057 (c), emissions attenuated more than 20 dB below the permissible limit are not reported
 Temp(Deg): 22.6 Hum(%RH): 70.3

System MU: 5.01 dB

Remarks: Passed Results Marginal Results Failed Results

SAC Transmitter Radiated Emission:

Model Number: M37TXS9PW1AN **S/N: 681P3A0078** **SR:08878-EMC-00004**
Battery Part No: NA **Accy Part No: 3466-HMN1079G-3,**
3466-HKN6163C-1, 254-HKN6170B-02, 1187-HKN6188B-1, 1187-PMHN4194A-1
Test Mode: TX APCO Digital C4FM

764.012500 MHz 12.5 kHz 1.000 Watt(s) /Low Power

Frequency (MHz)	Limit	Horizontal Measured Emission Equip Pwr Into Ideal Dipole (dBm)	Vertical Measured Emission Equip Pwr Into ideal Dipole (dBm)
1424.0000	-13.0000	-56.3000 *	-49.0000 *
1528.0250	-13.0000	-61.9130 **	-59.3029 **
1769.0000	-13.0000	-55.5900 *	-54.8200 *
2292.0375	-13.0000	-58.0017 **	-58.0587 **
3056.0500	-13.0000	-54.0362 **	-54.9555 **
3820.0625	-13.0000	-53.4074 **	-53.5980 **
4584.0750	-13.0000	-51.4985 **	-51.0173 **
5348.0875	-13.0000	-49.6047 **	-47.7854 **
6112.1000	-13.0000	-45.8566 **	-45.6355 **
6876.1125	-13.0000	-43.0256 **	-44.1447 **
7640.1250	-13.0000	-44.5172 **	-45.2342 **

RADIATED SPURIOUS EMISSIONS

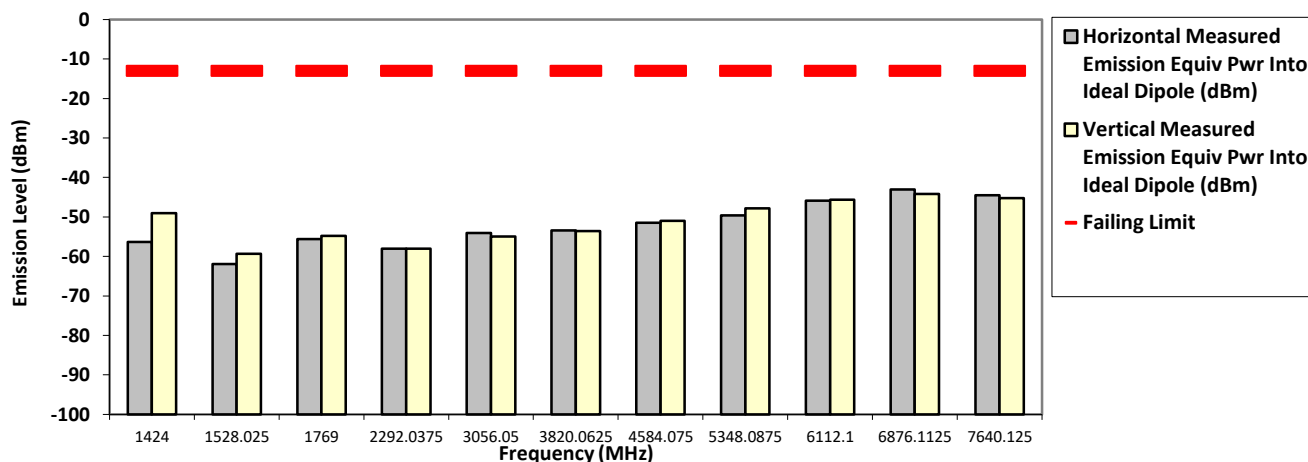

The data presented here was taken using the substitution method as found in the ANSI C63.26-2015 document.
 Motorola Penang EMC Lab - Test Performed by: Nazrin&Qawiman Sun, Apr 29, 2018

Remarks: ** Indicates the spurious emission could not be detected due to noise limitations or ambient.
 *Pursuant to CFR 47 Part 2.1057 (c), emissions attenuated more than 20 dB below the permissible limit are not reported
 Temp(Deg): 22.6 Hum(%RH): 70.3

System MU: 5.01 dB

Remarks: Passed Results Marginal Results Failed Results

SAC Transmitter Radiated Emission:

Model Number: M37TXS9PW1AN **S/N: 681P3A0078** **SR:08878-EMC-00004**
Battery Part No: NA **Accy Part No: 3466-HMN1079G-3,**
3466-HKN6163C-1, 254-HKN6170B-02, 1187-HKN6188B-1, 1187-PMHN4194A-1
Test Mode: TX APCO Digital C4FM

769.012500 MHz **12.5 kHz** **36.00 Watt(s) /Max Power**

Frequency (MHz)	Limit	Horizontal Measured Emission Equip Pwr Into Ideal Dipole (dBm)	Vertical Measured Emission Equip Pwr Into ideal Dipole (dBm)
1424.3500	-13.0000	-54.9400 *	-54.0700 *
1538.0250	-13.0000	-60.9817 **	-60.4290 **
2307.0375	-13.0000	-58.7566 **	-56.4200 **
3076.0500	-13.0000	-53.3257 **	-54.5763 **
3845.0625	-13.0000	-52.7734 **	-53.2597 **
4614.0750	-13.0000	-50.3561 **	-51.6436 **
5383.0875	-13.0000	-49.2805 **	-48.8690 **
6152.1000	-13.0000	-46.1969 **	-44.9769 **
6921.1125	-13.0000	-44.1762 **	-42.3665 **
7690.1250	-13.0000	-46.4078 **	-46.4807 **

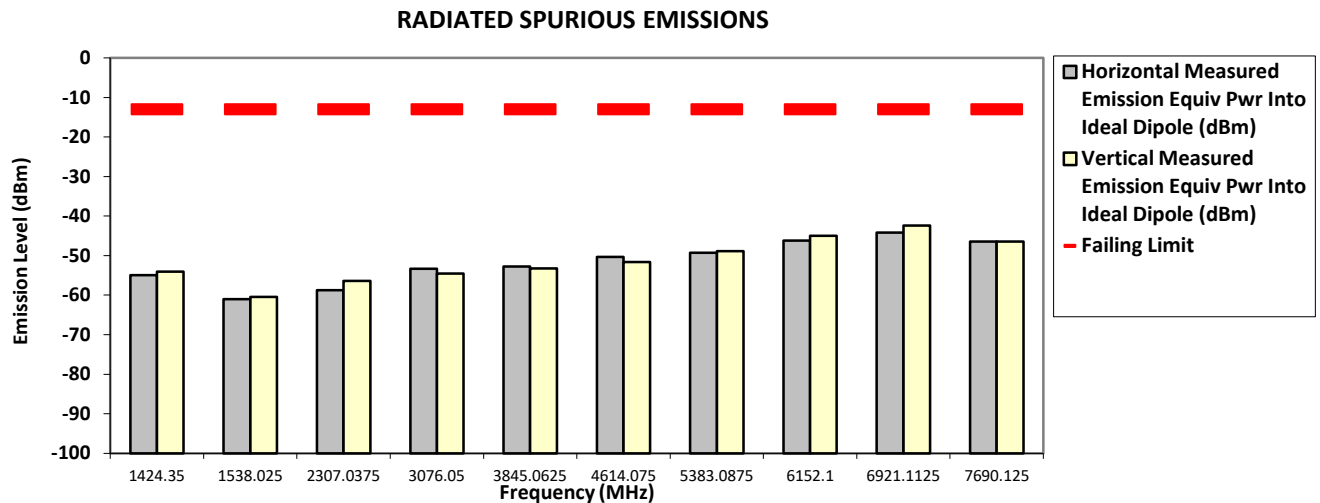

The data presented here was taken using the substitution method as found in the ANSI C63.26-2015 document.
 Motorola Penang EMC Lab - Test Performed by: Nazrin&Qawiman Mon, May 07, 2018

Remarks: ** Indicates the spurious emission could not be detected due to noise limitations or ambient.
 *Pursuant to CFR 47 Part 2.1057 (c), emissions attenuated more than 20 dB below the permissible limit are not reported
 Temp(Deg): 23.4 Hum(%RH): 70.9

System MU: 5.01 dB

Remarks:

Passed Results	Marginal Results	Failed Results
----------------	------------------	----------------

SAC Transmitter Radiated Emission:

Model Number: M37TXS9PW1AN **S/N: 681P3A0078** **SR:08878-EMC-00004**
Battery Part No: NA **Accy Part No: 3466-HMN1079G-3,**
3466-HKN6163C-1, 254-HKN6170B-02, 1187-HKN6188B-1, 1187-PMHN4194A-1
Test Mode: TX APCO Digital C4FM

769.087500 MHz **12.5 kHz** **36.000 Watt(s) /Max Power**

Frequency (MHz)	Limit	Horizontal Measured Emission Equip Pwr Into Ideal Dipole (dBm)	Vertical Measured Emission Equip Pwr Into ideal Dipole (dBm)
1424.0000	-13.0000	-56.1600 *	-52.1100 *
1440.0000	-13.0000	-54.5800 *	-43.3700 *
1456.2000	-13.0000	-57.3200 *	-45.8600 *
1538.1750	-13.0000	-53.3200 *	-53.2900 *
2307.2625	-13.0000	-56.1206 **	-54.3806 **
3076.3500	-13.0000	-47.4100 *	-42.6400 *
3845.4375	-13.0000	-52.2279 **	-53.2169 **
4614.5250	-13.0000	-49.4578 **	-51.5988 **
5383.6125	-13.0000	-49.3787 **	-47.0554 **
6152.7000	-13.0000	-45.6178 **	-46.7429 **
6921.7875	-13.0000	-44.2152 **	-44.9174 **
7690.8750	-13.0000	-45.1116 **	-44.0363 **

RADIATED SPURIOUS EMISSIONS

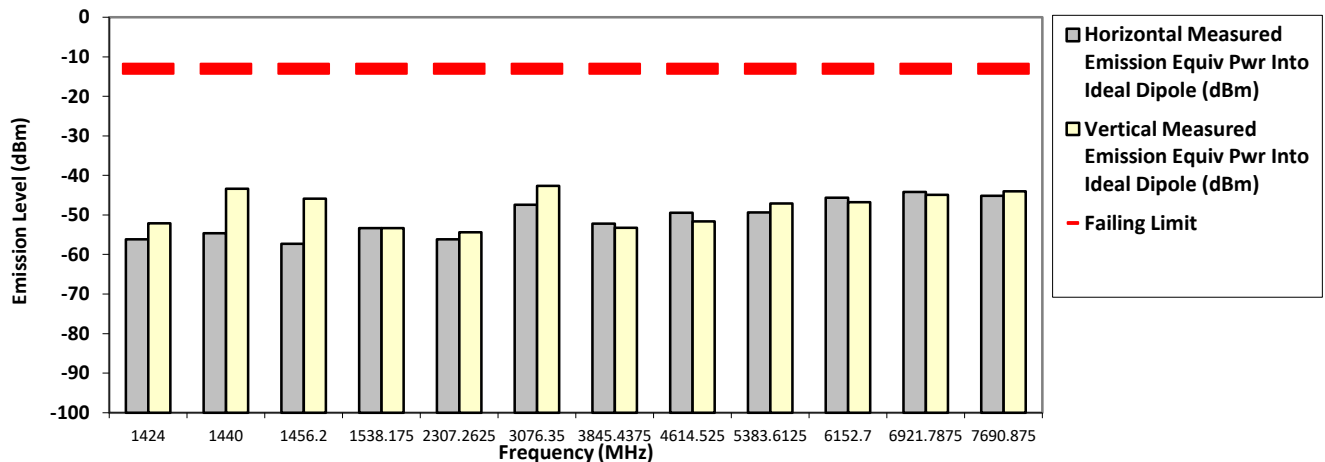

The data presented here was taken using the substitution method as found in the ANSI C63.26-2015 document.
 Motorola Penang EMC Lab - Test Performed by: Nazrin&Qawiman Sun, Apr 29, 2018

Remarks: ** Indicates the spurious emission could not be detected due to noise limitations or ambient.
 *Pursuant to CFR 47 Part 2.1057 (c), emissions attenuated more than 20 dB below the permissible limit are not reported
 Temp(Deg): 22.6 Hum(%RH): 70.3

System MU: 5.01 dB

Remarks: Passed Results Marginal Results Failed Results

SAC Transmitter Radiated Emission:

Model Number: M37TXS9PW1AN **S/N: 681P3A0078** **SR:08878-EMC-00004**
Battery Part No: NA **Accy Part No: 3466-HMN1079G-3,**
3466-HKN6163C-1, 254-HKN6170B-02, 1187-HKN6188B-1, 1187-PMHN4194A-1
Test Mode: TX APCO Digital C4FM

769.087500 MHz **12.5 kHz** **1.000 Watt(s) /Low Power**

Frequency (MHz)	Limit	Horizontal Measured Emission Equiv Pwr Into Ideal Dipole (dBm)	Vertical Measured Emission Equiv Pwr Into ideal Dipole (dBm)
1424.3500	-13.0000	-56.3200 *	-47.0800 *
1440.0000	-13.0000	-50.9900 *	-49.7500 *
1456.2000	-13.0000	-57.2700 *	-47.7900 *
1538.1750	-13.0000	-63.0476 **	-62.3545 **
2307.2625	-13.0000	-58.2236 **	-58.5884 **
3076.3500	-13.0000	-55.2120 **	-54.8871 **
3845.4375	-13.0000	-52.0171 **	-50.9565 **
4614.5250	-13.0000	-51.3530 **	-50.1308 **
5383.6125	-13.0000	-48.6866 **	-49.4239 **
6152.7000	-13.0000	-46.8010 **	-44.7884 **
6921.7875	-13.0000	-44.5712 **	-41.8321 **
7690.8750	-13.0000	-45.6790 **	-45.4555 **

RADIATED SPURIOUS EMISSIONS

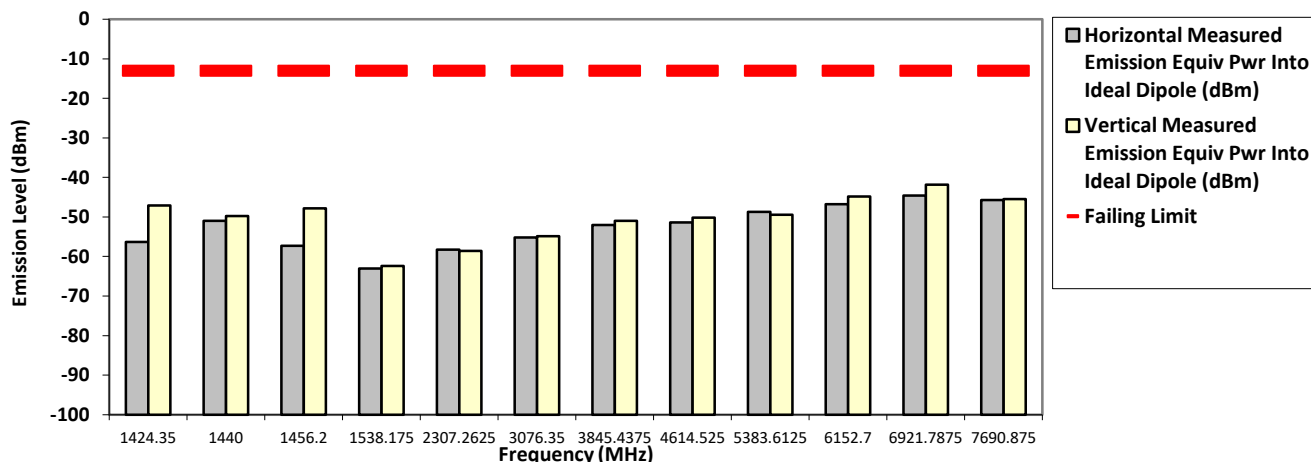

The data presented here was taken using the substitution method as found in the ANSI C63.26-2015 document.
 Motorola Penang EMC Lab - Test Performed by: Nazrin&Qawiman Sun, Apr 29, 2018

Remarks: ** Indicates the spurious emission could not be detected due to noise limitations or ambient.
 *Pursuant to CFR 47 Part 2.1057 (c), emissions attenuated more than 20 dB below the permissible limit are not reported
 Temp(Deg): 22.6 Hum(%RH): 70.3

System MU: 5.01 dB

Remarks: Passed Results Marginal Results Failed Results

SAC Transmitter Radiated Emission:

Model Number: M37TXS9PW1AN **S/N: 681P3A0078** **SR:08878-EMC-00004**
Battery Part No: NA **Accy Part No: 3466-HMN1079G-3,**
3466-HKN6163C-1, 254-HKN6170B-02, 1187-HKN6188B-1, 1187-PMHN4194A-1
Test Mode: TX APCO Digital C4FM

774.887500 MHz **12.5 kHz** **36.000 Watt(s) /Max Power**

Frequency (MHz)	Limit	Horizontal Measured Emission Equip Pwr Into Ideal Dipole (dBm)	Vertical Measured Emission Equip Pwr Into ideal Dipole (dBm)
1423.6500	-13.0000	-55.6300 *	-45.7800 *
1440.4500	-13.0000	-53.9300 *	-49.3900 *
1536.3500	-13.0000	-49.0900 *	-53.1300 *
1549.7750	-13.0000	-57.1301 **	-58.6027 **
2324.6625	-13.0000	-55.2164 **	-56.2882 **
3099.5500	-13.0000	-51.6382 **	-51.9874 **
3874.4375	-13.0000	-52.3173 **	-51.4114 **
4649.3250	-13.0000	-50.2315 **	-50.7171 **
5424.2125	-13.0000	-48.7528 **	-50.1395 **
6199.1000	-13.0000	-45.9420 **	-45.6142 **
6973.9875	-13.0000	-42.3818 **	-44.6683 **
7748.8750	-13.0000	-43.6988 **	-44.5489 **

RADIATED SPURIOUS EMISSIONS

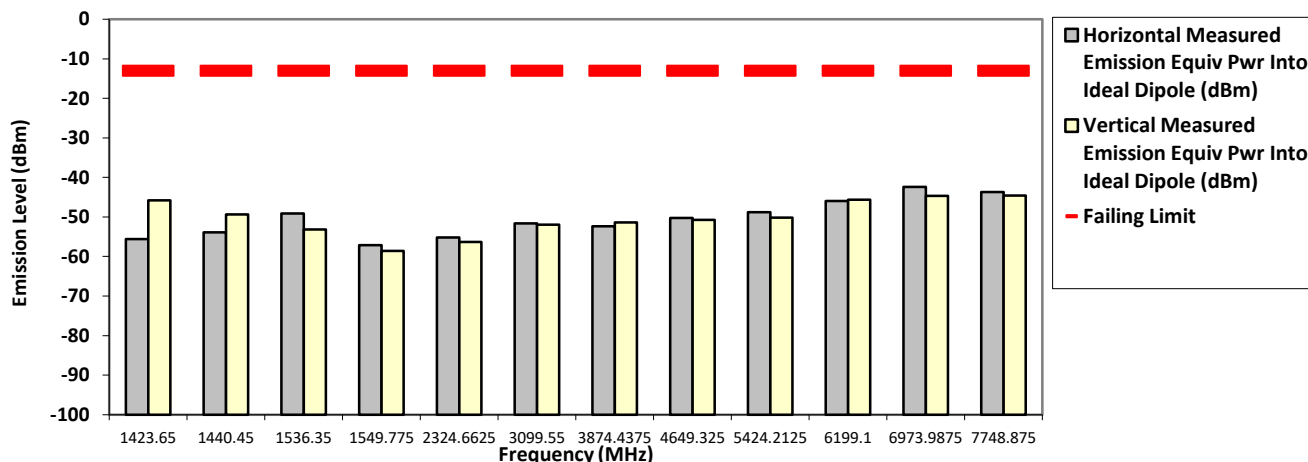

The data presented here was taken using the substitution method as found in the ANSI C63.26-2015 document.
 Motorola Penang EMC Lab - Test Performed by: Nazrin&Qawiman Sun, Apr 29, 2018

Remarks: ** Indicates the spurious emission could not be detected due to noise limitations or ambient.
 *Pursuant to CFR 47 Part 2.1057 (c), emissions attenuated more than 20 dB below the permissible limit are not reported
 Temp(Deg): 22.6 Hum(%RH): 70.3

System MU: 5.01 dB

Remarks: Passed Results Marginal Results Failed Results

SAC Transmitter Radiated Emission:

Model Number: M37TXS9PW1AN **S/N: 681P3A0078** **SR:08878-EMC-00004**
Battery Part No: NA **Accy Part No: 3466-HMN1079G-3,**
3466-HKN6163C-1, 254-HKN6170B-02, 1187-HKN6188B-1, 1187-PMHN4194A-1
Test Mode: TX APCO Digital C4FM

774.887500 MHz **12.5 kHz** **1.000 Watt(s) /Low Power**

Frequency (MHz)	Limit	Horizontal Measured Emission Equip Pwr Into Ideal Dipole (dBm)	Vertical Measured Emission Equip Pwr Into ideal Dipole (dBm)
1424.0000	-13.0000	-56.3600 *	-45.6700 *
1440.4500	-13.0000	-46.1600 *	-45.8500 *
1536.3500	-13.0000	-54.1200 *	-52.0900 *
1549.7750	-13.0000	-57.4874 **	-57.1627 **
2324.6625	-13.0000	-55.8427 **	-54.1987 **
3099.5500	-13.0000	-52.6086 **	-50.3003 **
3874.4375	-13.0000	-53.2700 **	-51.6488 **
4649.3250	-13.0000	-50.5752 **	-50.1098 **
5424.2125	-13.0000	-49.6240 **	-48.9501 **
6199.1000	-13.0000	-45.4761 **	-46.3367 **
6973.9875	-13.0000	-43.1600 **	-43.2512 **
7748.8750	-13.0000	-38.0000 *	-39.8700 *

RADIATED SPURIOUS EMISSIONS

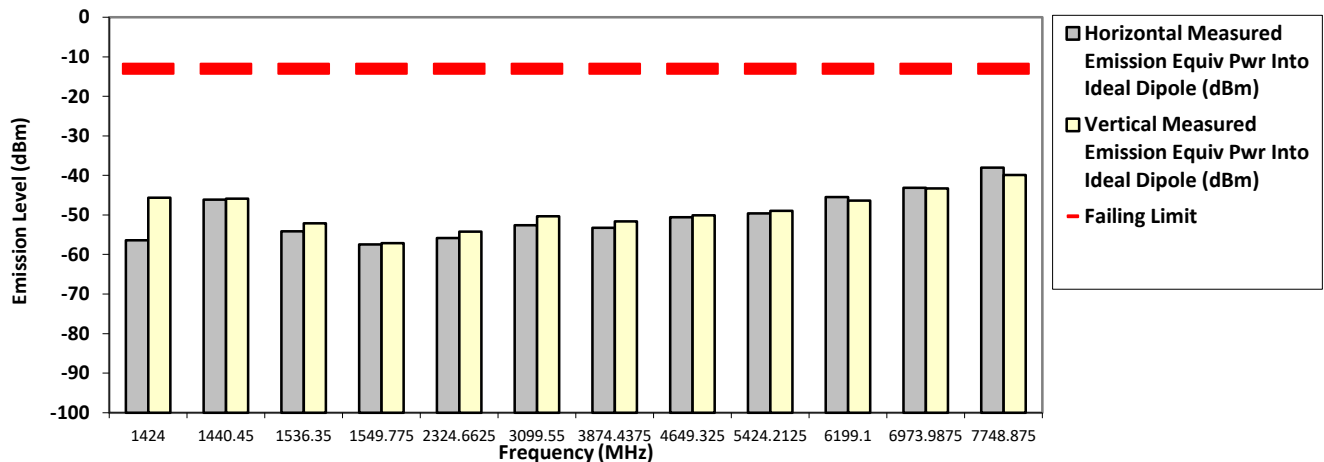

The data presented here was taken using the substitution method as found in the ANSI C63.26-2015 document.
 Motorola Penang EMC Lab - Test Performed by: Nazrin&Qawiman Sun, Apr 29, 2018

Remarks: ** Indicates the spurious emission could not be detected due to noise limitations or ambient.
 *Pursuant to CFR 47 Part 2.1057 (c), emissions attenuated more than 20 dB below the permissible limit are not reported
 Temp(Deg): 22.6 Hum(%RH): 70.3

System MU: 5.01 dB

Remarks: Passed Results Marginal Results Failed Results

SAC Transmitter Radiated Emission:

Model Number: M37TXS9PW1AN **S/N: 681P3A0078** **SR:08878-EMC-00004**
Battery Part No: NA **Accy Part No: 3466-HMN1079G-3,**
3466-HKN6163C-1, 254-HKN6170B-02, 1187-HKN6188B-1, 1187-PMHN4194A-1
Test Mode: TX APCO Digital C4FM

792.012500 MHz **12.5 kHz** **36.000 Watt(s) /Max Power**

Frequency (MHz)	Limit	Horizontal Measured Emission Equiv Pwr Into Ideal Dipole (dBm)	Vertical Measured Emission Equiv Pwr Into ideal Dipole (dBm)
1424.0000	-13.0000	-55.4300 *	-55.5600 *
1584.0250	-13.0000	-59.6613 **	-58.9644 **
2376.0375	-13.0000	-54.7047 **	-55.2218 **
3168.0500	-13.0000	-42.9500 *	-37.4100 *
3960.0625	-13.0000	-52.2603 **	-52.1868 **
4752.0750	-13.0000	-49.3892 **	-48.4211 **
5544.0875	-13.0000	-48.1169 **	-49.2585 **
6336.1000	-13.0000	-46.0437 **	-45.8793 **
7128.1125	-13.0000	-46.7090 **	-47.1300 **
7920.1250	-13.0000	-42.4033 **	-41.9147 **

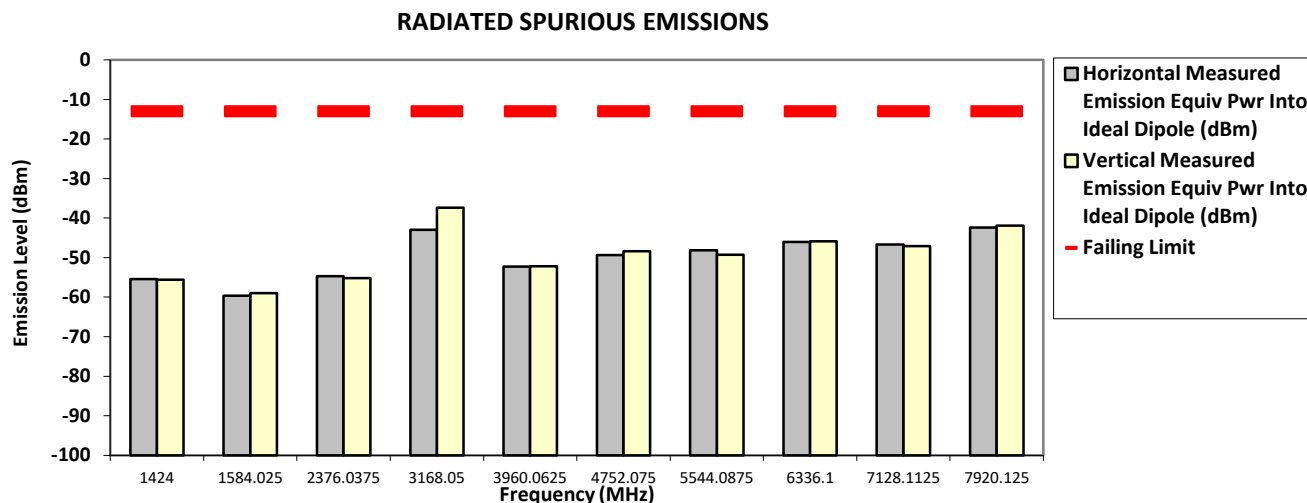

The data presented here was taken using the substitution method as found in the ANSI C63.26-2015 document.
 Motorola Penang EMC Lab - Test Performed by: Nazrin&Qawiman Mon, May 07, 2018

Remarks: ** Indicates the spurious emission could not be detected due to noise limitations or ambient.
 *Pursuant to CFR 47 Part 2.1057 (c), emissions attenuated more than 20 dB below the permissible limit are not reported
 Temp(Deg): 23.4 Hum(%RH): 70.9

System MU: 5.01 dB

Remarks:

Passed Results	Marginal Results	Failed Results
----------------	------------------	----------------

SAC Transmitter Radiated Emission:

Model Number: M37TXS9PW1AN **S/N: 681P3A0078** **SR:08878-EMC-00004**
Battery Part No: NA **Accy Part No: 3466-HMN1079G-3,**
3466-HKN6163C-1, 254-HKN6170B-02, 1187-HKN6188B-1, 1187-PMHN4194A-1
Test Mode: TX APCO Digital C4FM

792.012500 MHz 12.5 kHz 1.000 Watt(s) /Low Power

Frequency (MHz)	Limit	Horizontal Measured Emission Equiv Pwr Into Ideal Dipole (dBm)	Vertical Measured Emission Equiv Pwr Into ideal Dipole (dBm)
1440.1000	-13.0000	-55.7300 *	-54.7100 *
1584.0250	-13.0000	-58.7930 **	-59.1086 **
2376.0375	-13.0000	-56.9193 **	-56.8322 **
3168.0500	-13.0000	-53.4971 **	-53.6892 **
3960.0625	-13.0000	-52.0389 **	-52.2522 **
4752.0750	-13.0000	-51.1290 **	-49.5538 **
5544.0875	-13.0000	-48.5565 **	-49.2982 **
6336.1000	-13.0000	-45.9268 **	-46.0700 **
7128.1125	-13.0000	-46.9563 **	-47.2829 **
7920.1250	-13.0000	-44.5724 **	-45.4426 **

RADIATED SPURIOUS EMISSIONS

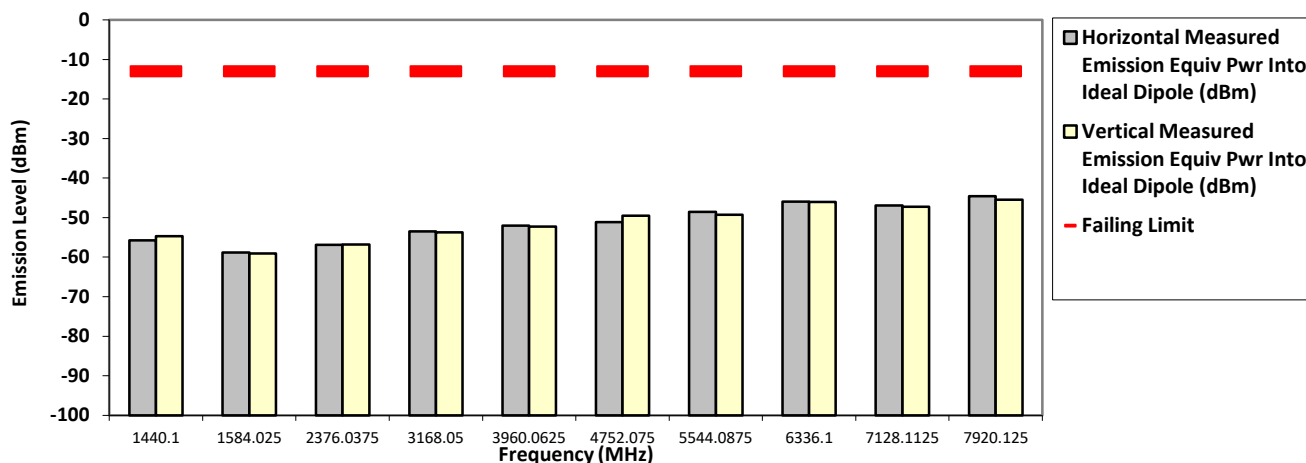

The data presented here was taken using the substitution method as found in the ANSI C63.26-2015 document.
 Motorola Penang EMC Lab - Test Performed by: Nazrin&Qawiman Mon, May 07, 2018

Remarks: ** Indicates the spurious emission could not be detected due to noise limitations or ambient.
 *Pursuant to CFR 47 Part 2.1057 (c), emissions attenuated more than 20 dB below the permissible limit are not reported
 Temp(Deg): 23.4 Hum(%RH): 70.9

System MU: 5.01 dB

Remarks:

Passed Results	Marginal Results	Failed Results
----------------	------------------	----------------

SAC Transmitter Radiated Emission:

Model Number: M37TXS9PW1AN **S/N: 681P3A0078** **SR:08878-EMC-00004**
Battery Part No: NA **Accy Part No: 3466-HMN1079G-3,**
3466-HKN6163C-1, 254-HKN6170B-02, 1187-HKN6188B-1, 1187-PMHN4194A-1
Test Mode: TX APCO Digital C4FM

799.087500 MHz **12.5 kHz** **36.000 Watt(s) /Max Power**

Frequency (MHz)	Limit	Horizontal Measured Emission Equip Pwr Into Ideal Dipole (dBm)	Vertical Measured Emission Equip Pwr Into ideal Dipole (dBm)
1424.3500	-13.0000	-55.7600 *	-41.9200 *
1440.1000	-13.0000	-50.8600 *	-44.5700 *
1456.2000	-13.0000	-57.0900 *	-47.8000 *
1598.1750	-13.0000	-53.2300 *	-54.6300 *
2397.2625	-13.0000	-43.8400 *	-46.2900 *
3196.3500	-13.0000	-44.0900 *	-38.1700 *
3995.4375	-13.0000	-51.6280 **	-52.5868 **
4794.5250	-13.0000	-49.3718 **	-47.5975 **
5593.6125	-13.0000	-48.3145 **	-48.5408 **
6392.7000	-13.0000	-44.9467 **	-43.6271 **
7191.7875	-13.0000	-45.4250 **	-45.9988 **
7990.8750	-13.0000	-38.8945 **	-35.8086 **

RADIATED SPURIOUS EMISSIONS

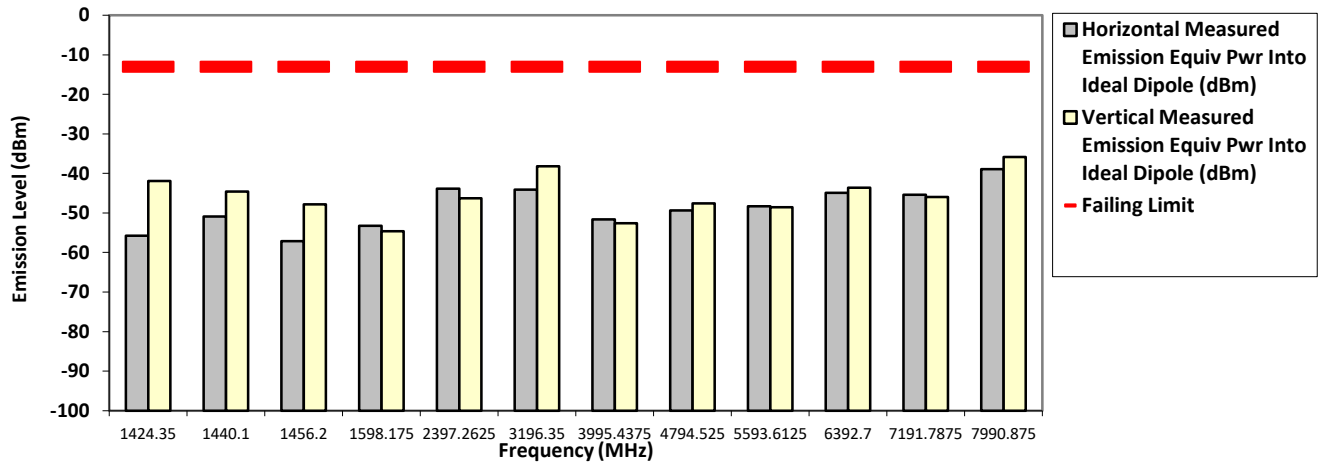

The data presented here was taken using the substitution method as found in the ANSI C63.26-2015 document.
 Motorola Penang EMC Lab - Test Performed by: Nazrin&Qawiman Sun, Apr 29, 2018

Remarks: ** Indicates the spurious emission could not be detected due to noise limitations or ambient.
 *Pursuant to CFR 47 Part 2.1057 (c), emissions attenuated more than 20 dB below the permissible limit are not reported
 Temp(Deg): 22.6 Hum(%RH): 70.3

System MU: 5.01 dB

Remarks: Passed Results Marginal Results Failed Results

SAC Transmitter Radiated Emission:

Model Number: M37TXS9PW1AN **S/N: 681P3A0078** **SR:08878-EMC-00004**
Battery Part No: NA **Accy Part No: 3466-HMN1079G-3,**
3466-HKN6163C-1, 254-HKN6170B-02, 1187-HKN6188B-1, 1187-PMHN4194A-1
Test Mode: TX APCO Digital C4FM

799.087500 MHz **12.5 kHz** **1.000 Watt(s) /Low Power**

Frequency (MHz)	Limit	Horizontal Measured Emission Equip Pwr Into Ideal Dipole (dBm)	Vertical Measured Emission Equip Pwr Into ideal Dipole (dBm)
1424.0000	-13.0000	-55.9000 *	-48.2700 *
1439.7500	-13.0000	-57.3900 *	-45.3900 *
1456.2000	-13.0000	-57.1200 *	-48.2600 *
1598.1750	-13.0000	-61.0974 **	-60.5798 **
2397.2625	-13.0000	-58.0102 **	-58.0145 **
3196.3500	-13.0000	-53.9111 **	-53.3969 **
3995.4375	-13.0000	-51.9666 **	-53.1022 **
4794.5250	-13.0000	-51.3506 **	-50.7578 **
5593.6125	-13.0000	-48.8144 **	-47.9004 **
6392.7000	-13.0000	-44.7511 **	-45.3761 **
7191.7875	-13.0000	-45.9773 **	-45.4797 **
7990.8750	-13.0000	-45.5358 **	-44.7636 **

RADIATED SPURIOUS EMISSIONS

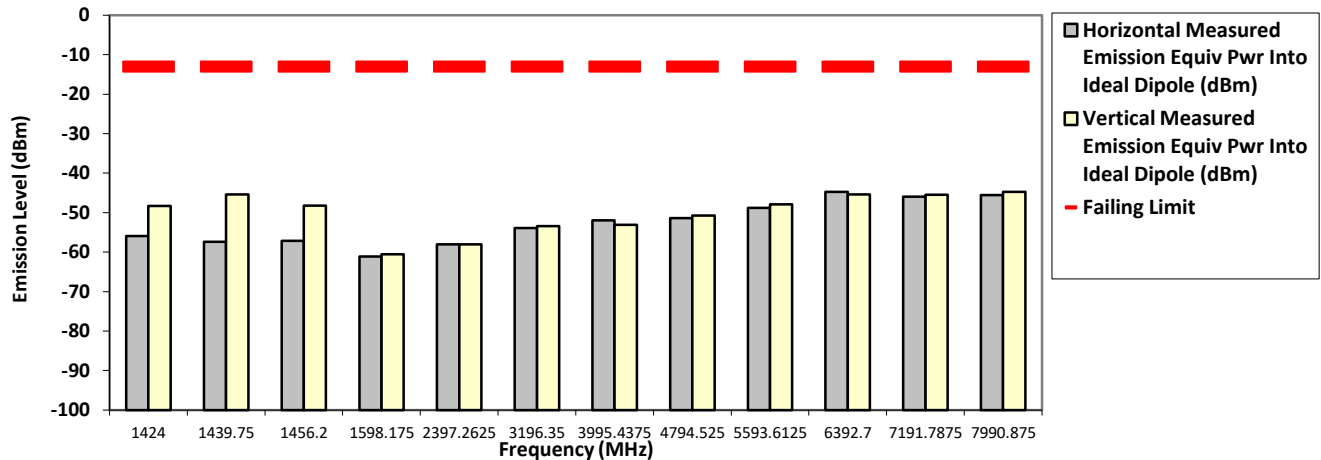

The data presented here was taken using the substitution method as found in the ANSI C63.26-2015 document.
 Motorola Penang EMC Lab - Test Performed by: Nazrin&Qawiman Sun, Apr 29, 2018

Remarks: ** Indicates the spurious emission could not be detected due to noise limitations or ambient.
 *Pursuant to CFR 47 Part 2.1057 (c), emissions attenuated more than 20 dB below the permissible limit are not reported
 Temp(Deg): 22.6 Hum(%RH): 70.3

System MU: 5.01 dB

Remarks: Passed Results Marginal Results Failed Results

SAC Transmitter Radiated Emission:

Model Number: M37TXS9PW1AN **S/N: 681P3A0078** **SR:08878-EMC-00004**
Battery Part No: NA **Accy Part No: 3466-HMN1079G-3,**
3466-HKN6163C-1, 254-HKN6170B-02, 1187-HKN6188B-1, 1187-PMHN4194A-1
Test Mode: TX APCO Digital C4FM

804.912500 MHz 12.5 kHz 36.000 Watt(s) /Max Power

Frequency (MHz)	Limit	Horizontal Measured Emission Equip Pwr Into Ideal Dipole (dBm)	Vertical Measured Emission Equip Pwr Into ideal Dipole (dBm)
1424.1800	-13.0000	-55.9800 *	-41.1800 *
1440.1800	-13.0000	-50.9100 *	-43.8600 *
1456.2000	-13.0000	-57.1300 *	-46.4700 *
1536.1700	-13.0000	-54.3900 *	-52.4500 *
1609.8250	-13.0000	-59.5832 **	-57.7243 **
2414.7375	-13.0000	-45.3900 *	-45.6700 *
3219.6500	-13.0000	-44.6800 *	-41.9600 *
4024.5625	-13.0000	-51.0789 **	-51.7079 **
4829.4750	-13.0000	-48.8101 **	-46.7485 **
5634.3875	-13.0000	-48.5867 **	-48.8442 **
6439.3000	-13.0000	-45.5228 **	-44.9038 **
7244.2125	-13.0000	-42.6514 **	-43.2778 **
8049.1250	-13.0000	-31.5200	-29.6000

RADIATED SPURIOUS EMISSIONS

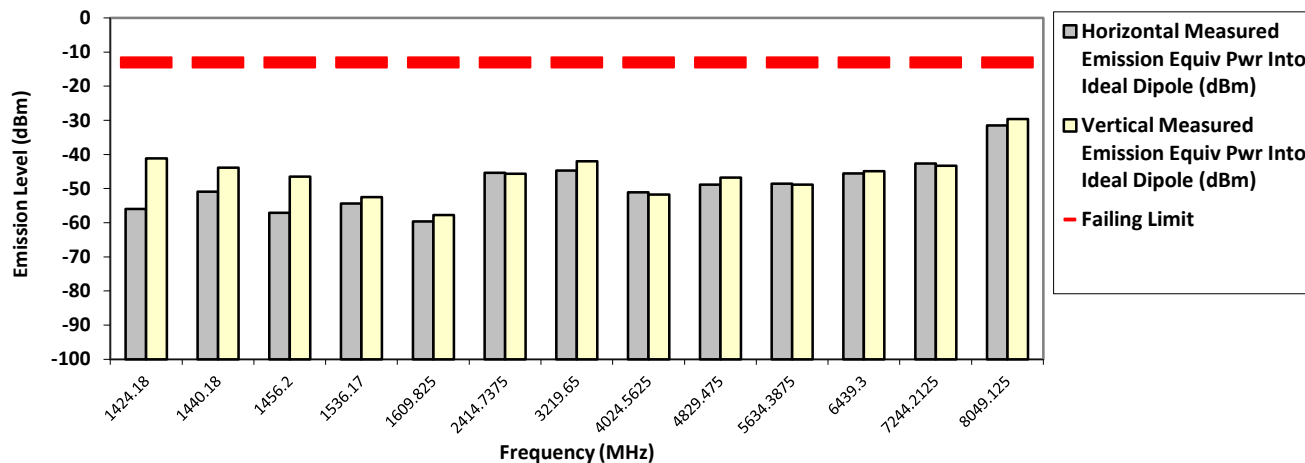

The data presented here was taken using the substitution method as found in the ANSI C63.26-2015 document.
 Motorola Penang EMC Lab - Test Performed by: Nazrin&Qawiman Sun, Apr 29, 2018

Remarks: ** Indicates the spurious emission could not be detected due to noise limitations or ambient.
 *Pursuant to CFR 47 Part 2.1057 (c), emissions attenuated more than 20 dB below the permissible limit are not reported
 Temp(Deg): 22.6 Hum(%RH): 70.3

System MU: 5.01 dB

Remarks: Passed Results Marginal Results Failed Results

SAC Transmitter Radiated Emission:

Model Number: M37TXS9PW1AN **S/N: 681P3A0078** **SR:08878-EMC-00004**
Battery Part No: NA **Accy Part No: 3466-HMN1079G-3,**
3466-HKN6163C-1, 254-HKN6170B-02, 1187-HKN6188B-1, 1187-PMHN4194A-1
Test Mode: TX APCO Digital C4FM

804.912500 MHz **12.5 kHz** **1.000 Watt(s) /Low Power**

Frequency (MHz)	Limit	Horizontal Measured Emission Equip Pwr Into Ideal Dipole (dBm)	Vertical Measured Emission Equip Pwr Into ideal Dipole (dBm)
1424.1800	-13.0000	-55.0600 *	-53.2700 *
1439.7800	-13.0000	-53.4700 *	-41.5000 *
1536.1700	-13.0000	-54.4500 *	-52.2900 *
1609.8250	-13.0000	-61.2927 **	-60.6952 **
2414.7375	-13.0000	-56.9329 **	-58.1447 **
3219.6500	-13.0000	-53.8628 **	-54.8577 **
4024.5625	-13.0000	-52.1304 **	-52.4956 **
4829.4750	-13.0000	-50.6958 **	-49.5098 **
5634.3875	-13.0000	-49.3134 **	-48.7710 **
6439.3000	-13.0000	-44.5608 **	-45.5323 **
7244.2125	-13.0000	-45.8980 **	-44.9627 **
8049.1250	-13.0000	-44.9429 **	-46.3600 **

RADIATED SPURIOUS EMISSIONS

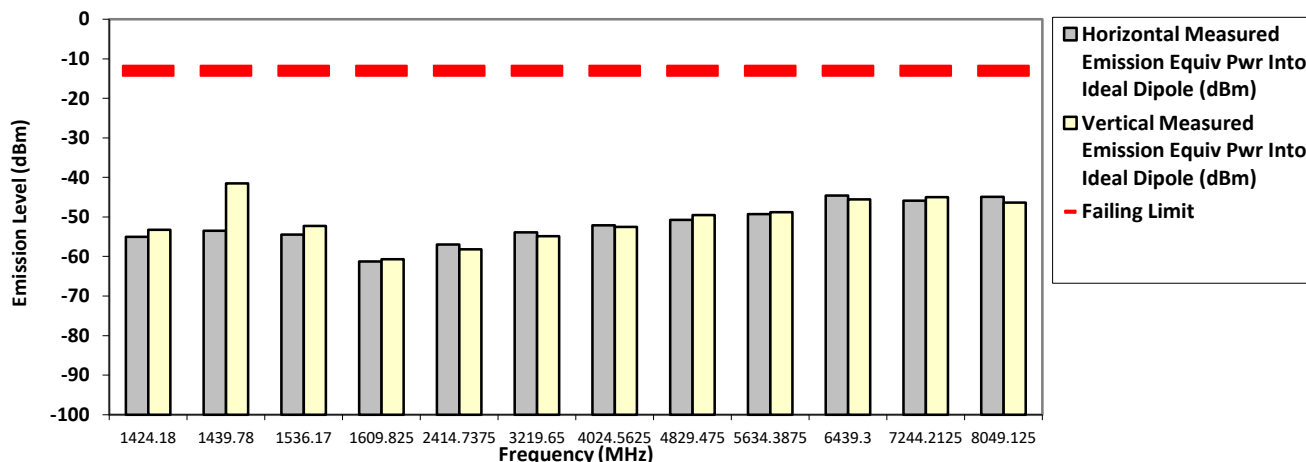

The data presented here was taken using the substitution method as found in the ANSI C63.26-2015 document.
 Motorola Penang EMC Lab - Test Performed by: Nazrin&Qawiman Sun, Apr 29, 2018

Remarks: ** Indicates the spurious emission could not be detected due to noise limitations or ambient.
 *Pursuant to CFR 47 Part 2.1057 (c), emissions attenuated more than 20 dB below the permissible limit are not reported
 Temp(Deg): 22.6 Hum(%RH): 70.3

System MU: 5.01 dB

Remarks: Passed Results Marginal Results Failed Results

SAC Transmitter Radiated Emission:

Model Number: M37TXS9PW1AN **S/N: 681P3A0078** **SR:08878-EMC-00004**
Battery Part No: NA **Accy Part No: 3466-HMN1079G-3,**
3466-HKN6163C-1, 254-HKN6170B-02, 1187-HKN6188B-1, 1187-PMHN4194A-1
Test Mode: TX APCO Digital Phase II

762.012500 MHz **12.5 kHz** **36.000 Watt(s) /Max Power**

Frequency (MHz)	Limit	Horizontal Measured Emission Equiv Pwr Into Ideal Dipole (dBm)	Vertical Measured Emission Equiv Pwr Into ideal Dipole (dBm)
1524.0250	-13.0000	-51.9000 *	-53.7700 *
2286.0375	-13.0000	-57.1320 **	-55.7509 **
3048.0500	-13.0000	-52.2170 **	-52.1450 **
3810.0625	-13.0000	-52.6352 **	-53.3394 **
4572.0750	-13.0000	-50.6816 **	-51.5692 **
5334.0875	-13.0000	-49.0425 **	-48.5374 **
6096.1000	-13.0000	-46.1249 **	-46.0957 **
6858.1125	-13.0000	-42.1033 **	-44.4635 **
7620.1250	-13.0000	-44.9010 **	-44.9215 **

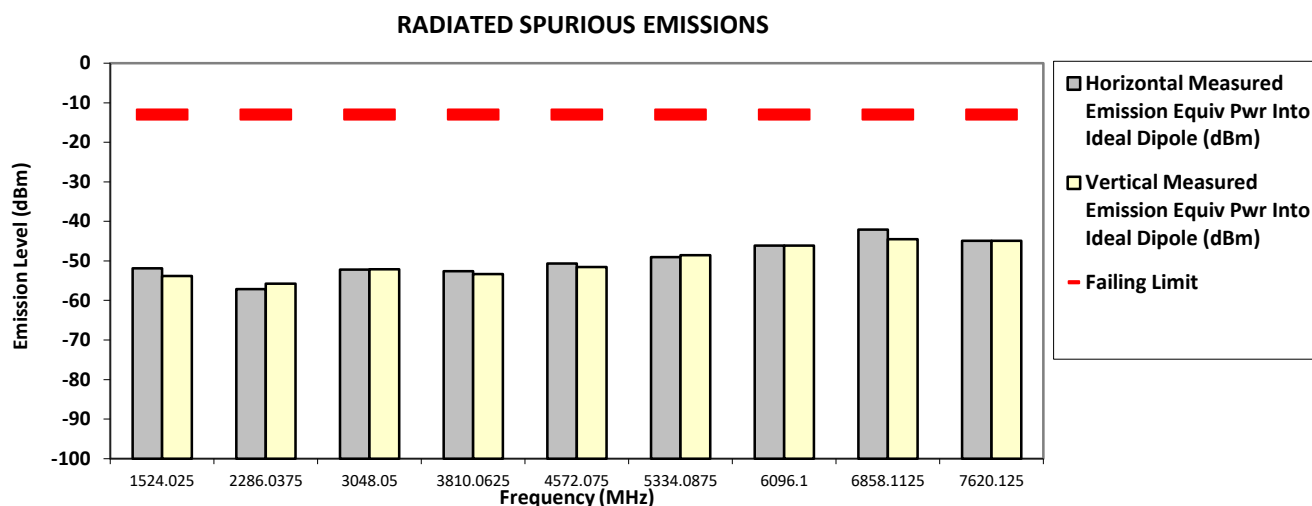

The data presented here was taken using the substitution method as found in the ANSI C63.26-2015 document.
 Motorola Penang EMC Lab - Test Performed by: Nazrin&Qawiman Mon, May 07, 2018

Remarks: ** Indicates the spurious emission could not be detected due to noise limitations or ambient.
 *Pursuant to CFR 47 Part 2.1057 (c), emissions attenuated more than 20 dB below the permissible limit are not reported
 Temp(Deg): 23.4 Hum(%RH): 70.9

System MU: 5.01 dB

Remarks: Passed Results Marginal Results Failed Results

SAC Transmitter Radiated Emission:

Model Number: M37TXS9PW1AN **S/N: 681P3A0078** **SR:08878-EMC-00004**
Battery Part No: NA **Accy Part No: 3466-HMN1079G-3,**
3466-HKN6163C-1, 254-HKN6170B-02, 1187-HKN6188B-1, 1187-PMHN4194A-1
Test Mode: TX APCO Digital Phase II

762.012500 MHz **12.5 kHz** **1.000 Watt(s) /Low Power**

Frequency (MHz)	Limit	Horizontal Measured Emission Equiv Pwr Into Ideal Dipole (dBm)	Vertical Measured Emission Equiv Pwr Into ideal Dipole (dBm)
1424.0000	-13.0000	-55.2000 *	-54.5300 *
1524.0250	-13.0000	-61.7652 **	-62.1940 **
2286.0375	-13.0000	-58.0800 **	-58.7253 **
3048.0500	-13.0000	-54.3152 **	-54.5232 **
3810.0625	-13.0000	-52.9541 **	-52.8453 **
4572.0750	-13.0000	-49.4962 **	-49.1078 **
5334.0875	-13.0000	-49.1511 **	-48.8152 **
6096.1000	-13.0000	-46.7247 **	-46.2627 **
6858.1125	-13.0000	-43.9518 **	-44.2294 **
7620.1250	-13.0000	-45.2876 **	-44.6550 **

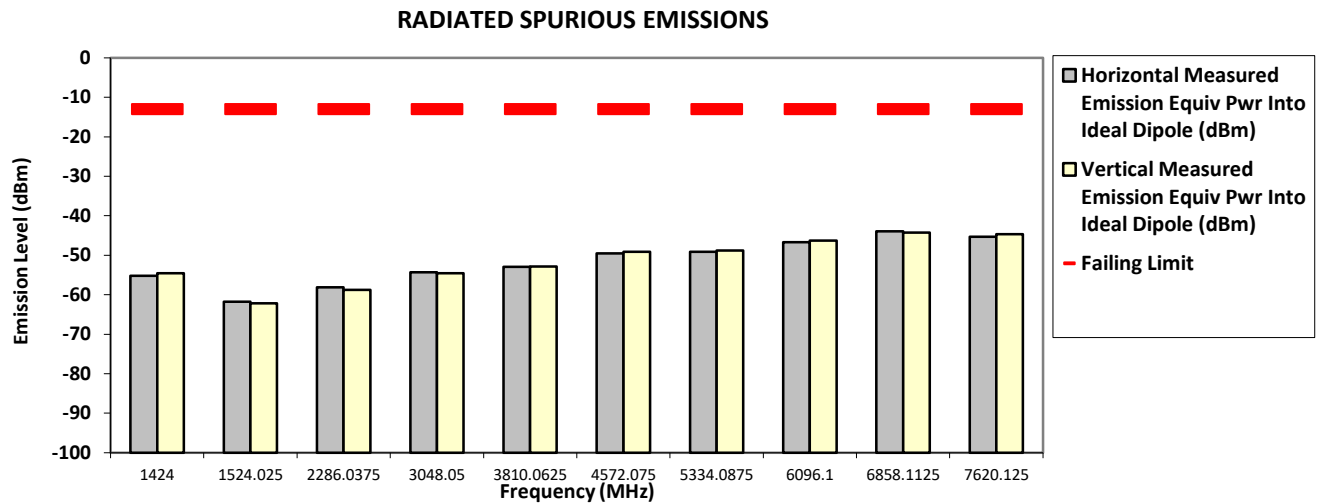

The data presented here was taken using the substitution method as found in the ANSI C63.26-2015 document.
 Motorola Penang EMC Lab - Test Performed by: Nazrin&Qawiman Mon, May 07, 2018

Remarks: ** Indicates the spurious emission could not be detected due to noise limitations or ambient.
 *Pursuant to CFR 47 Part 2.1057 (c), emissions attenuated more than 20 dB below the permissible limit are not reported
 Temp(Deg): 23.4 Hum(%RH): 70.9

System MU: 5.01 dB

Remarks: Passed Results Marginal Results Failed Results

SAC Transmitter Radiated Emission:

Model Number: M37TXS9PW1AN **S/N: 681P3A0078** **SR:08878-EMC-00004**
Battery Part No: NA **Accy Part No: 3466-HMN1079G-3,**
3466-HKN6163C-1, 254-HKN6170B-02, 1187-HKN6188B-1, 1187-PMHN4194A-1
Test Mode: TX APCO Digital Phase II

764.012500 MHz **12.5 kHz** **36.000 Watt(s) /Max Power**

Frequency (MHz)	Limit	Horizontal Measured Emission Equip Pwr Into Ideal Dipole (dBm)	Vertical Measured Emission Equip Pwr Into ideal Dipole (dBm)
1408.2500	-13.0000	-56.4300 *	-42.8900 *
1424.0000	-13.0000	-55.3900 *	-46.8800 *
1440.1000	-13.0000	-50.1800 *	-42.6500 *
1528.0250	-13.0000	-52.3800 *	-49.9800 *
2292.0375	-13.0000	-56.9304 **	-54.8707 **
3056.0500	-13.0000	-51.4801 **	-50.2283 **
3820.0625	-13.0000	-52.7085 **	-51.2860 **
4584.0750	-13.0000	-51.4096 **	-51.3115 **
5348.0875	-13.0000	-48.9337 **	-49.2121 **
6112.1000	-13.0000	-46.2524 **	-45.5320 **
6876.1125	-13.0000	-43.5036 **	-43.8852 **
7640.1250	-13.0000	-43.6656 **	-42.2930 **

RADIATED SPURIOUS EMISSIONS

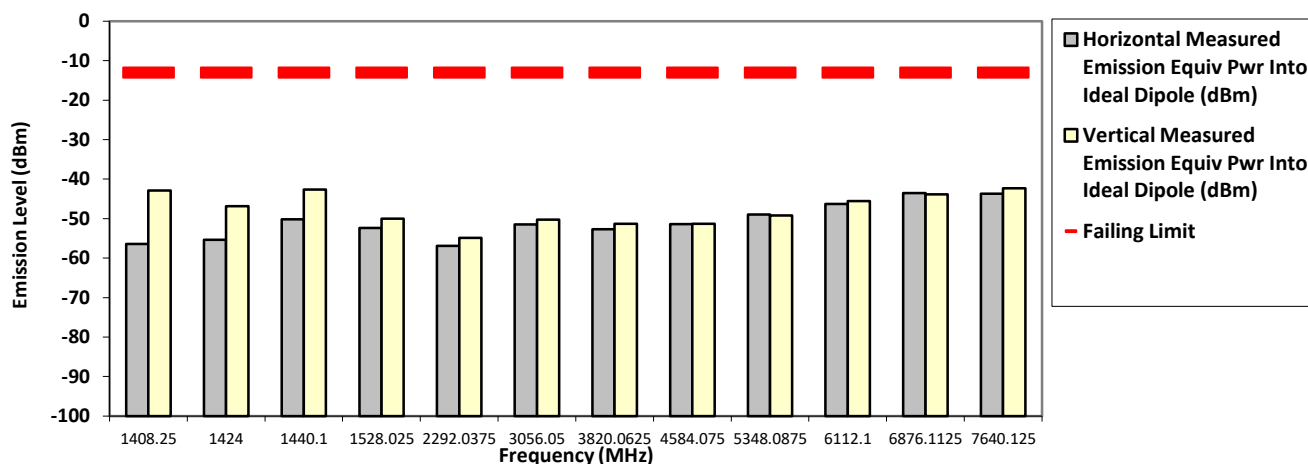

The data presented here was taken using the substitution method as found in the ANSI C63.26-2015 document.
 Motorola Penang EMC Lab - Test Performed by: Nazrin&Qawiman Sun, Apr 29, 2018

Remarks: ** Indicates the spurious emission could not be detected due to noise limitations or ambient.
 *Pursuant to CFR 47 Part 2.1057 (c), emissions attenuated more than 20 dB below the permissible limit are not reported
 Temp(Deg): 22.6 Hum(%RH): 70.3

System MU: 5.01 dB

Remarks: Passed Results Marginal Results Failed Results

SAC Transmitter Radiated Emission:

Model Number: M37TXS9PW1AN **S/N: 681P3A0078** **SR:08878-EMC-00004**
Battery Part No: NA **Accy Part No: 3466-HMN1079G-3,**
3466-HKN6163C-1, 254-HKN6170B-02, 1187-HKN6188B-1, 1187-PMHN4194A-1
Test Mode: TX APCO Digital Phase II

764.012500 MHz **12.5 kHz** **1.000 Watt(s) /Low Power**

Frequency (MHz)	Limit	Horizontal Measured Emission Equip Pwr Into Ideal Dipole (dBm)	Vertical Measured Emission Equip Pwr Into ideal Dipole (dBm)
1424.0000	-13.0000	-55.1500 *	-49.5300 *
1440.1000	-13.0000	-51.3800 *	-44.3900 *
1528.0250	-13.0000	-60.9041 **	-62.1605 **
1536.0000	-13.0000	-52.4200 *	-50.8800 *
2292.0375	-13.0000	-57.7257 **	-58.5099 **
3056.0500	-13.0000	-53.5143 **	-54.9269 **
3820.0625	-13.0000	-52.5362 **	-52.9601 **
4584.0750	-13.0000	-51.2201 **	-51.3845 **
5348.0875	-13.0000	-49.6066 **	-48.6225 **
6112.1000	-13.0000	-46.2619 **	-46.4596 **
6876.1125	-13.0000	-43.9838 **	-43.0622 **
7640.1250	-13.0000	-45.6722 **	-45.9650 **

RADIATED SPURIOUS EMISSIONS

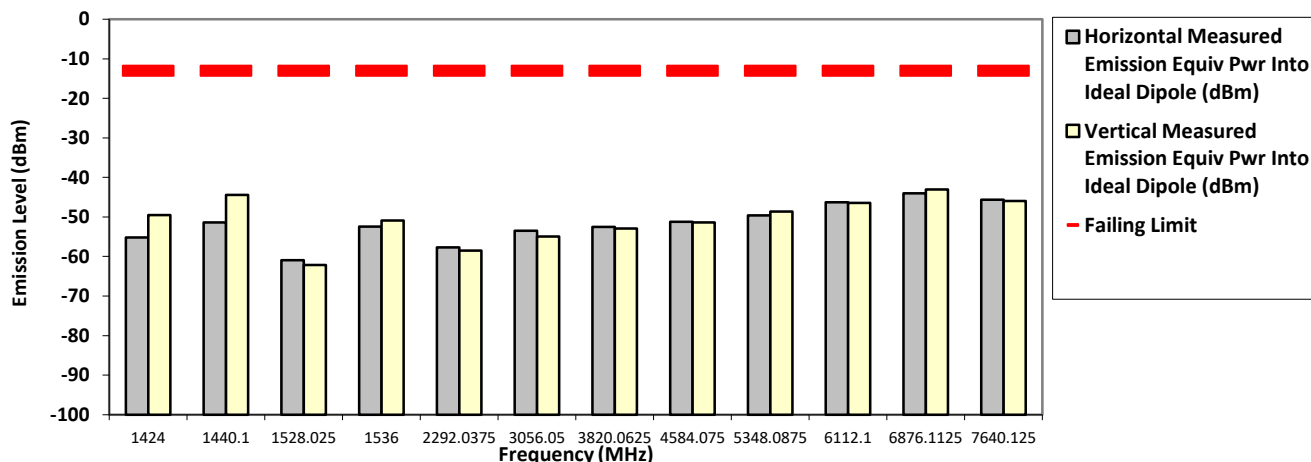

The data presented here was taken using the substitution method as found in the ANSI C63.26-2015 document.
 Motorola Penang EMC Lab - Test Performed by: Nazrin&Qawiman Sun, Apr 29, 2018

Remarks: ** Indicates the spurious emission could not be detected due to noise limitations or ambient.
 *Pursuant to CFR 47 Part 2.1057 (c), emissions attenuated more than 20 dB below the permissible limit are not reported
 Temp(Deg): 22.6 Hum(%RH): 70.3

System MU: 5.01 dB

Remarks: Passed Results Marginal Results Failed Results

SAC Transmitter Radiated Emission:

Model Number: M37TXS9PW1AN **S/N: 681P3A0078** **SR:08878-EMC-00004**
Battery Part No: NA **Accy Part No: 3466-HMN1079G-3,**
3466-HKN6163C-1, 254-HKN6170B-02, 1187-HKN6188B-1, 1187-PMHN4194A-1
Test Mode: TX APCO Digital Phase II

769.012500 MHz **12.5 kHz** **36.000 Watt(s) /Max Power**

Frequency (MHz)	Limit	Horizontal Measured Emission Equip Pwr Into Ideal Dipole (dBm)	Vertical Measured Emission Equip Pwr Into ideal Dipole (dBm)
1440.1000	-13.0000	-54.5700 *	-54.8400 *
1538.0250	-13.0000	-60.7831 **	-61.9429 **
2307.0375	-13.0000	-58.4590 **	-57.4701 **
3076.0500	-13.0000	-55.4184 **	-55.0703 **
3845.0625	-13.0000	-52.9437 **	-53.6056 **
4614.0750	-13.0000	-51.2098 **	-51.0760 **
5383.0875	-13.0000	-49.1756 **	-49.4809 **
6152.1000	-13.0000	-46.8920 **	-46.4037 **
6921.1125	-13.0000	-44.0270 **	-44.6953 **
7690.1250	-13.0000	-45.3547 **	-45.5752 **

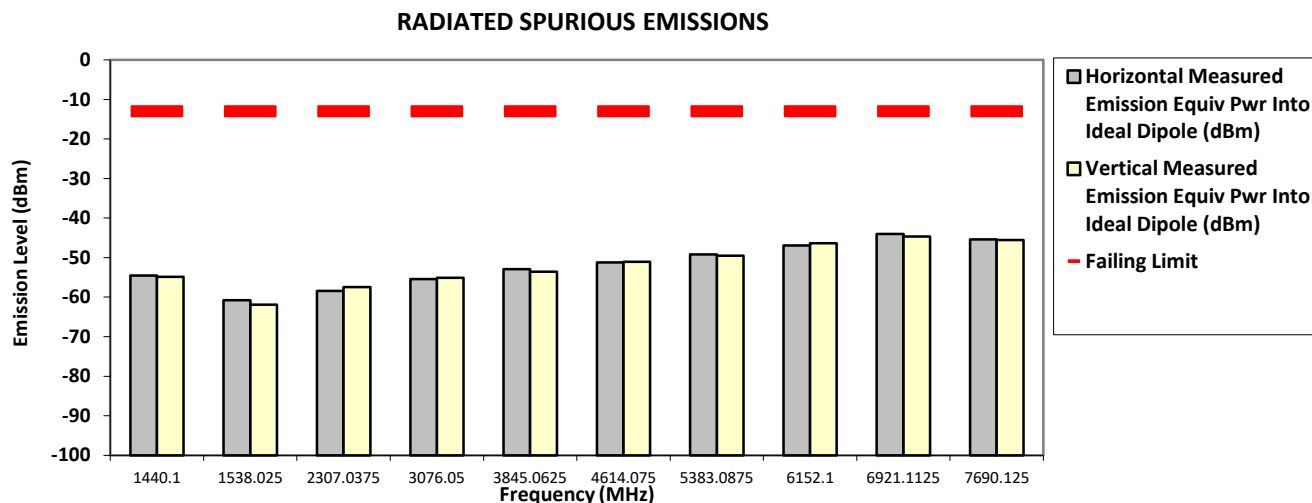

The data presented here was taken using the substitution method as found in the ANSI C63.26-2015 document.
 Motorola Penang EMC Lab - Test Performed by: Nazrin&Qawiman Mon, May 07, 2018

Remarks: ** Indicates the spurious emission could not be detected due to noise limitations or ambient.
 *Pursuant to CFR 47 Part 2.1057 (c), emissions attenuated more than 20 dB below the permissible limit are not reported
 Temp(Deg): 23.4 Hum(%RH): 70.9

System MU: 5.01 dB

Remarks:

Passed Results	Marginal Results	Failed Results
----------------	------------------	----------------

SAC Transmitter Radiated Emission:

Model Number: M37TXS9PW1AN **S/N: 681P3A0078** **SR:08878-EMC-00004**
Battery Part No: NA **Accy Part No: 3466-HMN1079G-3,**
3466-HKN6163C-1, 254-HKN6170B-02, 1187-HKN6188B-1, 1187-PMHN4194A-1
Test Mode: TX APCO Digital Phase II

769.087500 MHz **12.5 kHz** **36.000 Watt(s) /Max Power**

Frequency (MHz)	Limit	Horizontal Measured Emission Equip Pwr Into Ideal Dipole (dBm)	Vertical Measured Emission Equip Pwr Into ideal Dipole (dBm)
1407.9000	-13.0000	-53.1900 *	-43.0600 *
1424.0000	-13.0000	-55.5200 *	-48.3200 *
1440.1000	-13.0000	-56.3300 *	-42.9100 *
1455.8500	-13.0000	-56.5700 *	-47.1500 *
1538.1750	-13.0000	-52.3800 *	-51.3000 *
2307.2625	-13.0000	-55.5699 **	-54.3453 **
3076.3500	-13.0000	-53.8318 **	-51.7330 **
3845.4375	-13.0000	-51.8535 **	-52.7242 **
4614.5250	-13.0000	-51.1796 **	-51.2471 **
5383.6125	-13.0000	-48.9440 **	-49.0699 **
6152.7000	-13.0000	-44.9548 **	-45.2417 **
6921.7875	-13.0000	-43.1152 **	-44.1614 **
7690.8750	-13.0000	-45.7688 **	-44.9628 **

RADIATED SPURIOUS EMISSIONS

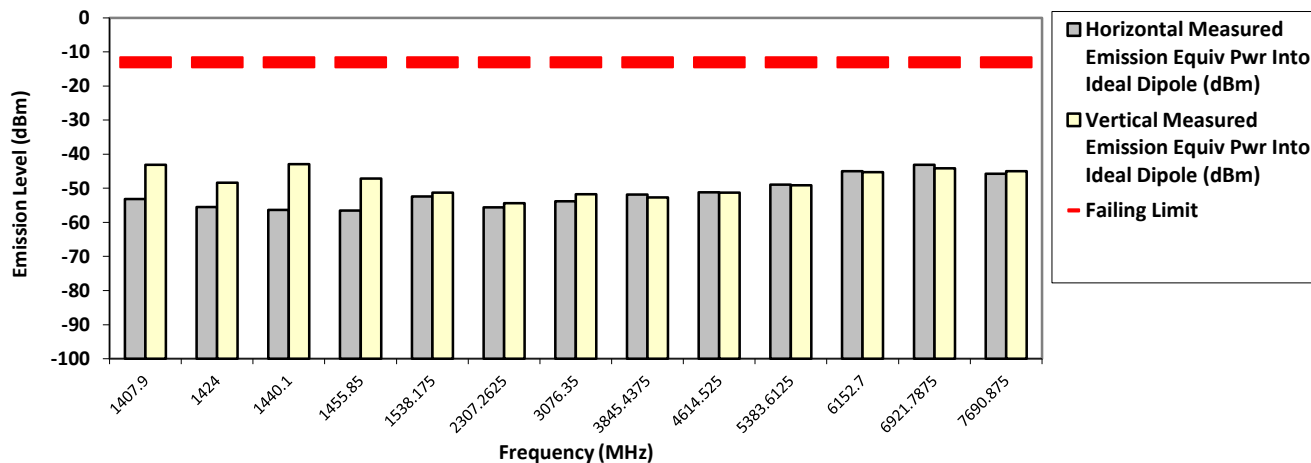

The data presented here was taken using the substitution method as found in the ANSI C63.26-2015 document.
 Motorola Penang EMC Lab - Test Performed by: Nazrin&Qawiman Sun, Apr 29, 2018

Remarks: ** Indicates the spurious emission could not be detected due to noise limitations or ambient.

*Pursuant to CFR 47 Part 2.1057 (c), emissions attenuated more than 20 dB below the permissible limit are not reported
 Temp(Deg): 22.6 Hum(%RH): 70.3

System MU: 5.01 dB

Remarks: Passed Results Marginal Results Failed Results

SAC Transmitter Radiated Emission:

Model Number: M37TXS9PW1AN **S/N: 681P3A0078** **SR:08878-EMC-00004**
Battery Part No: NA **Accy Part No: 3466-HMN1079G-3,**
3466-HKN6163C-1, 254-HKN6170B-02, 1187-HKN6188B-1, 1187-PMHN4194A-1
Test Mode: TX APCO Digital Phase II

769.087500 MHz **12.5 kHz** **1.000 Watt(s) /Low Power**

Frequency (MHz)	Limit	Horizontal Measured Emission Equip Pwr Into Ideal Dipole (dBm)	Vertical Measured Emission Equip Pwr Into ideal Dipole (dBm)
1424.3500	-13.0000	-55.4600 *	-40.6600 *
1440.1000	-13.0000	-49.6000 *	-40.3800 *
1536.3500	-13.0000	-54.1200 *	-51.6300 *
2307.2625	-13.0000	-58.7417 **	-57.3825 **
3076.3500	-13.0000	-54.4006 **	-54.5519 **
3845.4375	-13.0000	-52.6724 **	-52.5840 **
4614.5250	-13.0000	-51.3123 **	-50.6233 **
5383.6125	-13.0000	-49.1730 **	-49.7080 **
6152.7000	-13.0000	-45.5000 **	-46.2539 **
6921.7875	-13.0000	-44.2432 **	-43.7152 **
7690.8750	-13.0000	-46.1411 **	-45.5347 **

RADIATED SPURIOUS EMISSIONS

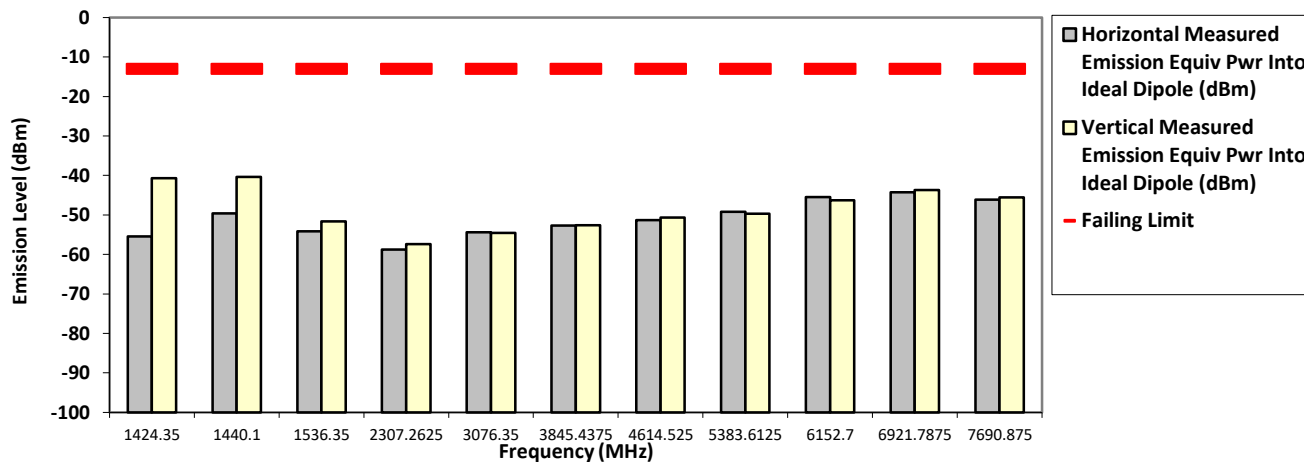

The data presented here was taken using the substitution method as found in the ANSI C63.26-2015 document.
 Motorola Penang EMC Lab - Test Performed by: Nazrin&Qawiman Sun, Apr 29, 2018

Remarks: ** Indicates the spurious emission could not be detected due to noise limitations or ambient.
 *Pursuant to CFR 47 Part 2.1057 (c), emissions attenuated more than 20 dB below the permissible limit are not reported
 Temp(Deg): 22.6 Hum(%RH): 70.3

System MU: 5.01 dB

Remarks: Passed Results Marginal Results Failed Results

SAC Transmitter Radiated Emission:

Model Number: M37TXS9PW1AN **S/N: 681P3A0078** **SR:08878-EMC-00004**
Battery Part No: NA **Accy Part No: 3466-HMN1079G-3,**
3466-HKN6163C-1, 254-HKN6170B-02, 1187-HKN6188B-1, 1187-PMHN4194A-1
Test Mode: TX APCO Digital Phase II

774.887500 MHz **12.5 kHz** **36.000 Watt(s) /Max Power**

Frequency (MHz)	Limit	Horizontal Measured Emission Equiv Pwr Into Ideal Dipole (dBm)	Vertical Measured Emission Equiv Pwr Into ideal Dipole (dBm)
1424.0000	-13.0000	-55.2600 *	-48.4500 *
1455.8500	-13.0000	-56.8700 *	-50.8000 *
1536.0000	-13.0000	-52.7500 *	-51.8800 *
1549.7750	-13.0000	-57.7456 **	-57.6831 **
2324.6625	-13.0000	-55.2738 **	-54.9534 **
3099.5500	-13.0000	-53.2253 **	-51.1049 **
3874.4375	-13.0000	-52.9572 **	-51.5634 **
4649.3250	-13.0000	-50.7806 **	-49.4918 **
5424.2125	-13.0000	-49.0143 **	-47.9919 **
6199.1000	-13.0000	-46.1911 **	-46.1830 **
6973.9875	-13.0000	-43.5918 **	-43.2290 **
7748.8750	-13.0000	-34.9600 *	-34.8900 *

RADIATED SPURIOUS EMISSIONS

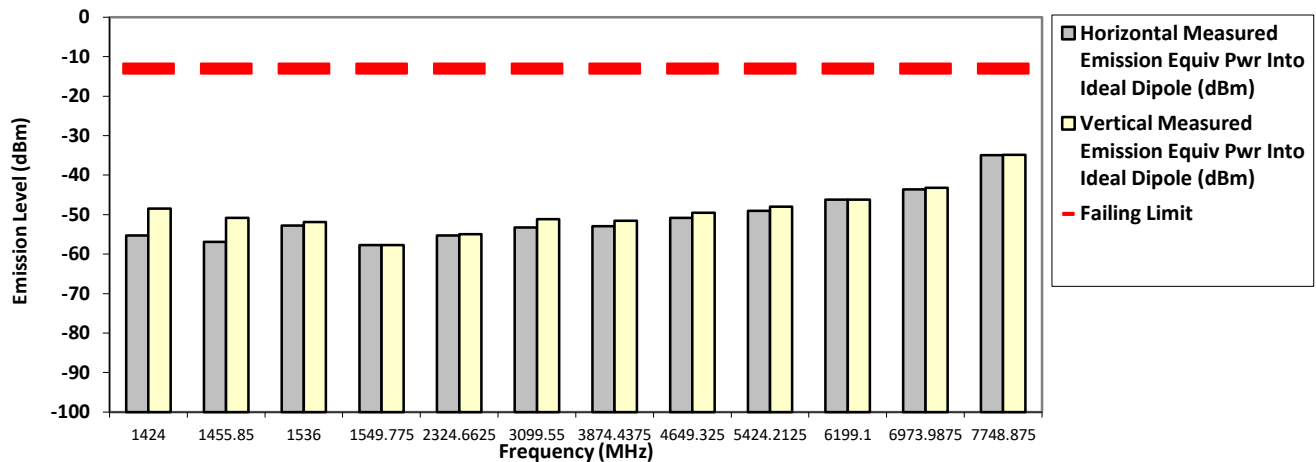

The data presented here was taken using the substitution method as found in the ANSI C63.26-2015 document.
 Motorola Penang EMC Lab - Test Performed by: Nazrin&Qawiman Sun, Apr 29, 2018

Remarks: ** Indicates the spurious emission could not be detected due to noise limitations or ambient.
 *Pursuant to CFR 47 Part 2.1057 (c), emissions attenuated more than 20 dB below the permissible limit are not reported
 Temp(Deg): 22.6 Hum(%RH): 70.3

System MU: 5.01 dB

Remarks: Passed Results Marginal Results Failed Results

SAC Transmitter Radiated Emission:

Model Number: M37TXS9PW1AN **S/N: 681P3A0078** **SR:08878-EMC-00004**
Battery Part No: NA **Accy Part No: 3466-HMN1079G-3,**
3466-HKN6163C-1, 254-HKN6170B-02, 1187-HKN6188B-1, 1187-PMHN4194A-1
Test Mode: TX APCO Digital Phase II

774.887500 MHz **12.5 kHz** **1.000 Watt(s) /Low Power**

Frequency (MHz)	Limit	Horizontal Measured Emission Equip Pwr Into Ideal Dipole (dBm)	Vertical Measured Emission Equip Pwr Into ideal Dipole (dBm)
1424.3500	-13.0000	-54.3100 *	-47.7300 *
1439.7500	-13.0000	-55.4500 *	-41.4400 *
1536.0000	-13.0000	-53.7600 *	-50.2200 *
1549.7750	-13.0000	-61.2290 **	-61.6676 **
2324.6625	-13.0000	-57.6424 **	-58.2058 **
3099.5500	-13.0000	-54.2989 **	-54.2832 **
3874.4375	-13.0000	-51.7091 **	-53.1610 **
4649.3250	-13.0000	-49.7737 **	-51.0828 **
5424.2125	-13.0000	-48.8172 **	-46.3759 **
6199.1000	-13.0000	-45.0306 **	-44.5192 **
6973.9875	-13.0000	-43.4551 **	-43.4306 **
7748.8750	-13.0000	-45.1747 **	-45.3793 **

RADIATED SPURIOUS EMISSIONS

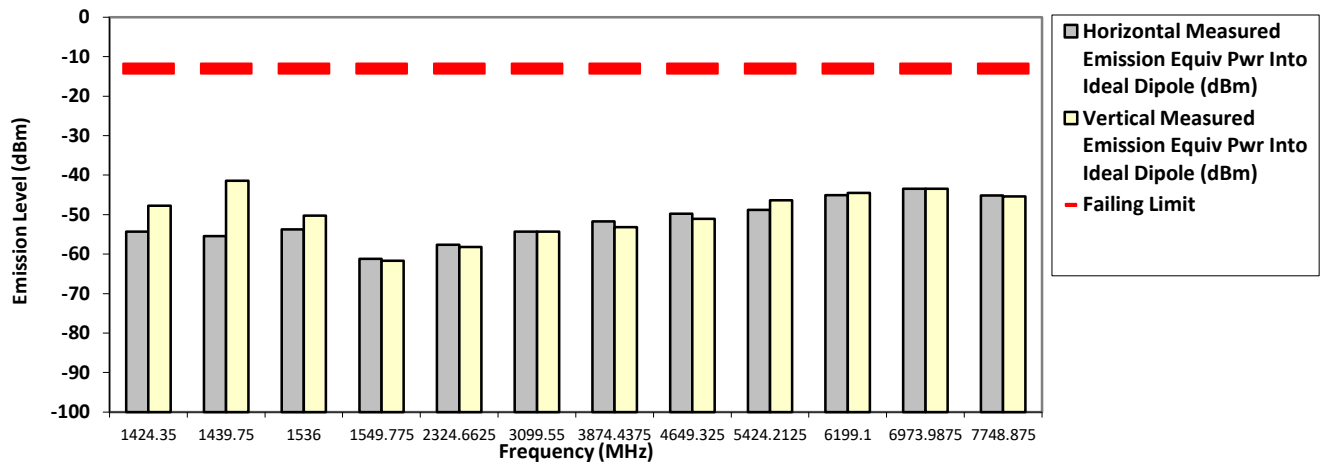

The data presented here was taken using the substitution method as found in the ANSI C63.26-2015 document.
 Motorola Penang EMC Lab - Test Performed by: Nazrin&Qawiman Mon, Apr 30, 2018

Remarks: ** Indicates the spurious emission could not be detected due to noise limitations or ambient.
 *Pursuant to CFR 47 Part 2.1057 (c), emissions attenuated more than 20 dB below the permissible limit are not reported
 Temp(Deg): 22.6 Hum(%RH): 70.3

System MU: 5.01 dB

Remarks: Passed Results Marginal Results Failed Results

SAC Transmitter Radiated Emission:

Model Number: M37TXS9PW1AN **S/N: 681P3A0078** **SR:08878-EMC-00004**
Battery Part No: NA **Accy Part No: 3466-HMN1079G-3,**
3466-HKN6163C-1, 254-HKN6170B-02, 1187-HKN6188B-1, 1187-PMHN4194A-1
Test Mode: TX APCO Digital Phase II

792.012500 MHz **12.5 kHz** **36.000 Watt(s) /Max Power**

Frequency (MHz)	Limit	Horizontal Measured Emission Equiv Pwr Into Ideal Dipole (dBm)	Vertical Measured Emission Equiv Pwr Into ideal Dipole (dBm)
1424.0000	-13.0000	-55.9000 *	-54.9900 *
1584.0250	-13.0000	-59.0564 **	-59.6478 **
2376.0375	-13.0000	-55.9982 **	-56.3222 **
3168.0500	-13.0000	-44.5300 *	-40.5700 *
3960.0625	-13.0000	-52.1273 **	-50.4128 **
4752.0750	-13.0000	-50.1083 **	-50.4712 **
5544.0875	-13.0000	-49.3219 **	-48.3760 **
6336.1000	-13.0000	-46.2362 **	-45.7129 **
7128.1125	-13.0000	-47.3607 **	-46.3878 **
7920.1250	-13.0000	-43.0176 **	-41.9048 **

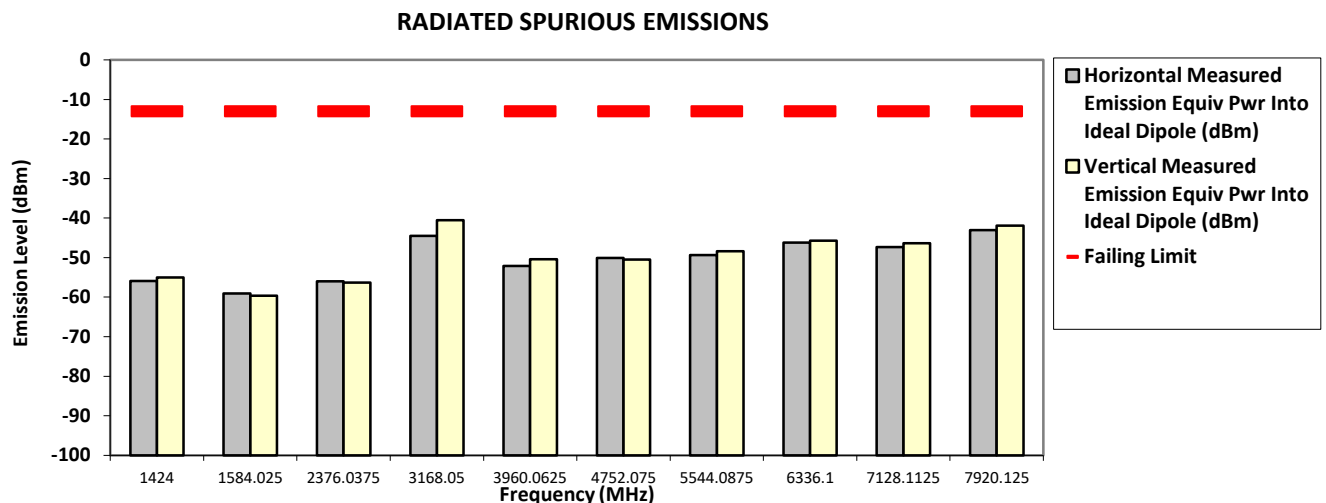

The data presented here was taken using the substitution method as found in the ANSI C63.26-2015 document.
 Motorola Penang EMC Lab - Test Performed by: Nazrin&Qawiman Mon, May 07, 2018

Remarks: ** Indicates the spurious emission could not be detected due to noise limitations or ambient.
 *Pursuant to CFR 47 Part 2.1057 (c), emissions attenuated more than 20 dB below the permissible limit are not reported
 Temp(Deg): 23.4 Hum(%RH): 70.9

System MU: 5.01 dB

Remarks:

Passed Results	Marginal Results	Failed Results
----------------	------------------	----------------

SAC Transmitter Radiated Emission:

Model Number: M37TXS9PW1AN **S/N: 681P3A0078** **SR:08878-EMC-00004**
Battery Part No: NA **Accy Part No: 3466-HMN1079G-3,**
3466-HKN6163C-1, 254-HKN6170B-02, 1187-HKN6188B-1, 1187-PMHN4194A-1
Test Mode: TX APCO Digital Phase II

792.012500 MHz **12.5 kHz** **1.000 Watt(s) /Low Power**

Frequency (MHz)	Limit	Horizontal Measured Emission Equip Pwr Into Ideal Dipole (dBm)	Vertical Measured Emission Equip Pwr Into ideal Dipole (dBm)
1584.0250	-20.0000	-60.4978 **	-60.8301 **
2376.0375	-20.0000	-57.8807 **	-58.1117 **
3168.0500	-20.0000	-54.1828 **	-53.6304 **
3960.0625	-20.0000	-52.7855 **	-52.2323 **
4752.0750	-20.0000	-50.1692 **	-49.4884 **
5544.0875	-20.0000	-47.4007 **	-49.4156 **
6336.1000	-20.0000	-45.3827 **	-45.8842 **
7128.1125	-20.0000	-47.0160 **	-47.0124 **
7920.1250	-20.0000	-45.9606 **	-44.4833 **

RADIATED SPURIOUS EMISSIONS

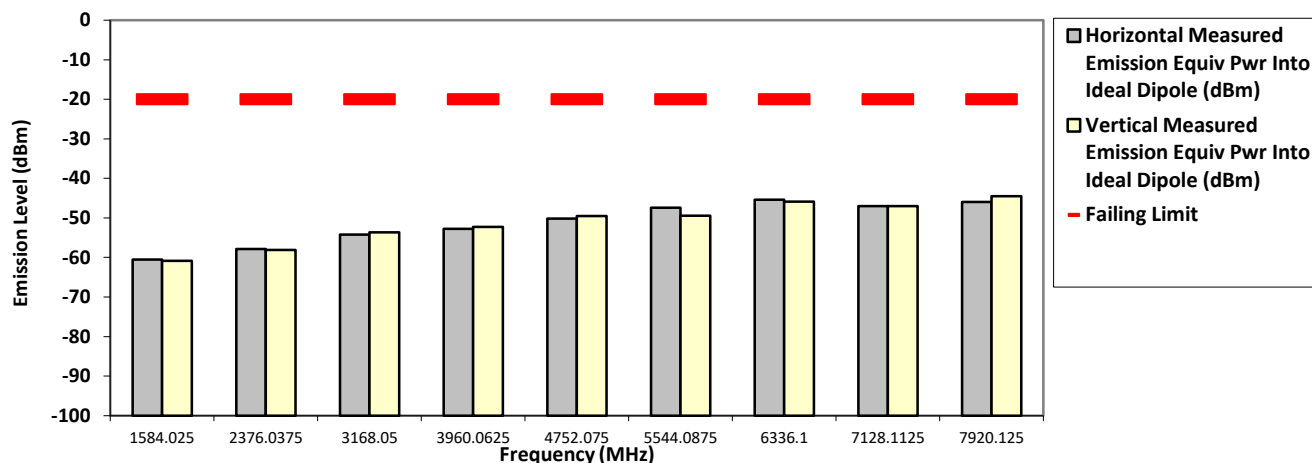

The data presented here was taken using the substitution method as found in the ANSI C63.26-2015 document.
 Motorola Penang EMC Lab - Test Performed by: Nazrin&Qawiman Mon, May 07, 2018

Remarks: ** Indicates the spurious emission could not be detected due to noise limitations or ambient.
 *Pursuant to CFR 47 Part 2.1057 (c), emissions attenuated more than 20 dB below the permissible limit are not reported
 Temp(Deg): 23.4 Hum(%RH): 70.9

System MU: 5.01 dB

Remarks: Passed Results Marginal Results Failed Results

SAC Transmitter Radiated Emission:

Model Number: M37TXS9PW1AN **S/N: 681P3A0078** **SR:08878-EMC-00004**
Battery Part No: NA **Accy Part No: 3466-HMN1079G-3,**
3466-HKN6163C-1, 254-HKN6170B-02, 1187-HKN6188B-1, 1187-PMHN4194A-1
Test Mode: TX APCO Digital Phase II

799.087500 MHz **12.5 kHz** **36.000 Watt(s) /Max Power**

Frequency (MHz)	Limit	Horizontal Measured Emission Equiv Pwr Into Ideal Dipole (dBm)	Vertical Measured Emission Equiv Pwr Into ideal Dipole (dBm)
1424.0000	-13.0000	-55.6500 *	-42.2300 *
1536.0000	-13.0000	-54.4000 *	-47.5200 *
1598.1750	-13.0000	-58.1553 **	-56.4954 **
2397.2625	-13.0000	-48.6300 *	-51.8700 *
3196.3500	-13.0000	-49.4000 *	-48.4700 *
3995.4375	-13.0000	-53.2106 **	-52.8456 **
4794.5250	-13.0000	-49.2668 **	-47.3439 **
5593.6125	-13.0000	-48.4455 **	-48.4342 **
6392.7000	-13.0000	-45.9997 **	-44.4469 **
7191.7875	-13.0000	-47.0558 **	-44.3987 **
7990.8750	-13.0000	-37.2000 *	-38.9700 *

RADIATED SPURIOUS EMISSIONS

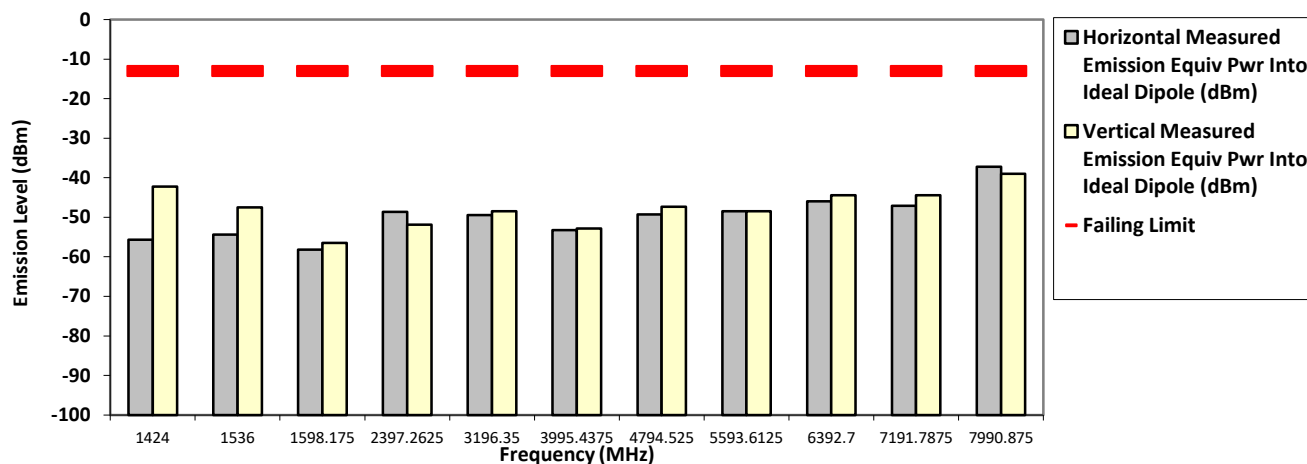

The data presented here was taken using the substitution method as found in the ANSI C63.26-2015 document.
 Motorola Penang EMC Lab - Test Performed by: Nazrin&Qawiman Sun, Apr 29, 2018

Remarks: ** Indicates the spurious emission could not be detected due to noise limitations or ambient.
 *Pursuant to CFR 47 Part 2.1057 (c), emissions attenuated more than 20 dB below the permissible limit are not reported
 Temp(Deg): 22.6 Hum(%RH): 70.3

System MU: 5.01 dB

Remarks: Passed Results Marginal Results Failed Results

SAC Transmitter Radiated Emission:

Model Number: M37TXS9PW1AN **S/N: 681P3A0078** **SR:08878-EMC-00004**
Battery Part No: NA **Accy Part No: 3466-HMN1079G-3,**
3466-HKN6163C-1, 254-HKN6170B-02, 1187-HKN6188B-1, 1187-PMHN4194A-1
Test Mode: TX APCO Digital Phase II

799.087500 MHz **12.5 kHz** **1.000 Watt(s) /Low Power**

Frequency (MHz)	Limit	Horizontal Measured Emission Equip Pwr Into Ideal Dipole (dBm)	Vertical Measured Emission Equip Pwr Into ideal Dipole (dBm)
1424.0000	-13.0000	-52.4500 *	-42.9300 *
1440.1000	-13.0000	-56.0200 *	-36.5100 *
1455.8500	-13.0000	-56.0000 *	-42.7300 *
1536.3500	-13.0000	-54.1100 *	-49.2900 *
1598.1750	-13.0000	-60.6608 **	-60.9586 **
2397.2625	-13.0000	-58.7291 **	-57.8331 **
3196.3500	-13.0000	-53.6527 **	-53.4491 **
3995.4375	-13.0000	-52.7487 **	-53.4199 **
4794.5250	-13.0000	-50.8204 **	-50.4057 **
5593.6125	-13.0000	-49.2915 **	-48.8316 **
6392.7000	-13.0000	-44.8617 **	-46.1850 **
7191.7875	-13.0000	-46.7657 **	-45.8378 **
7990.8750	-13.0000	-44.5809 **	-44.7830 **

RADIATED SPURIOUS EMISSIONS

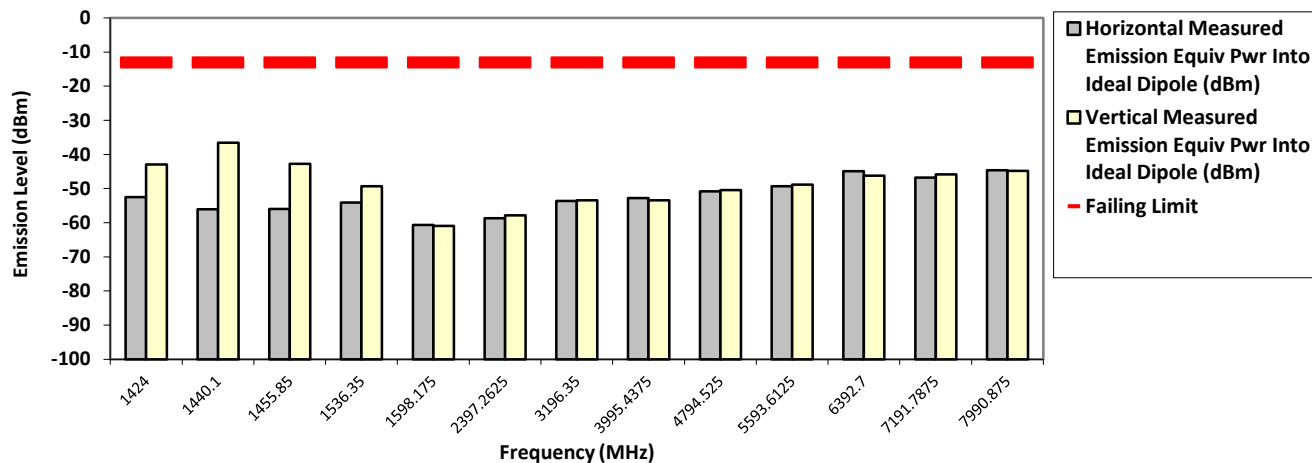

The data presented here was taken using the substitution method as found in the ANSI C63.26-2015 document.
 Motorola Penang EMC Lab - Test Performed by: Nazrin&Qawiman Mon, Apr 30, 2018

Remarks: ** Indicates the spurious emission could not be detected due to noise limitations or ambient.
 *Pursuant to CFR 47 Part 2.1057 (c), emissions attenuated more than 20 dB below the permissible limit are not reported
 Temp(Deg): 22.6 Hum(%RH): 70.3

System MU: 5.01 dB

Remarks: Passed Results Marginal Results Failed Results

SAC Transmitter Radiated Emission:

Model Number: M37TXS9PW1AN **S/N: 681P3A0078** **SR:08878-EMC-00004**
Battery Part No: NA **Accy Part No: 3466-HMN1079G-3,**
3466-HKN6163C-1, 254-HKN6170B-02, 1187-HKN6188B-1, 1187-PMHN4194A-1
Test Mode: TX APCO Digital Phase II

804.912500 MHz **12.5 kHz** **36.000 Watt(s) /Max Power**

Frequency (MHz)	Limit	Horizontal Measured Emission Equiv Pwr Into Ideal Dipole (dBm)	Vertical Measured Emission Equiv Pwr Into ideal Dipole (dBm)
1424.1800	-13.0000	-55.9000 *	-43.0000 *
1440.1800	-13.0000	-47.5300 *	-44.3200 *
1536.1700	-13.0000	-54.1900 *	-46.5100 *
1609.8250	-13.0000	-60.0952 **	-58.8169 **
1781.7600	-13.0000	-55.3000 *	-48.2600 *
2414.7375	-13.0000	-46.7800 *	-45.2000 *
3219.6500	-13.0000	-45.4700 *	-43.0900 *
4024.5625	-13.0000	-50.8825 **	-51.6444 **
4829.4750	-13.0000	-48.8956 **	-47.5485 **
5634.3875	-13.0000	-48.5686 **	-48.1226 **
6439.3000	-13.0000	-46.2820 **	-43.8835 **
7244.2125	-13.0000	-43.7351 **	-43.2074 **
8049.1250	-13.0000	-30.7300	-27.5500

RADIATED SPURIOUS EMISSIONS

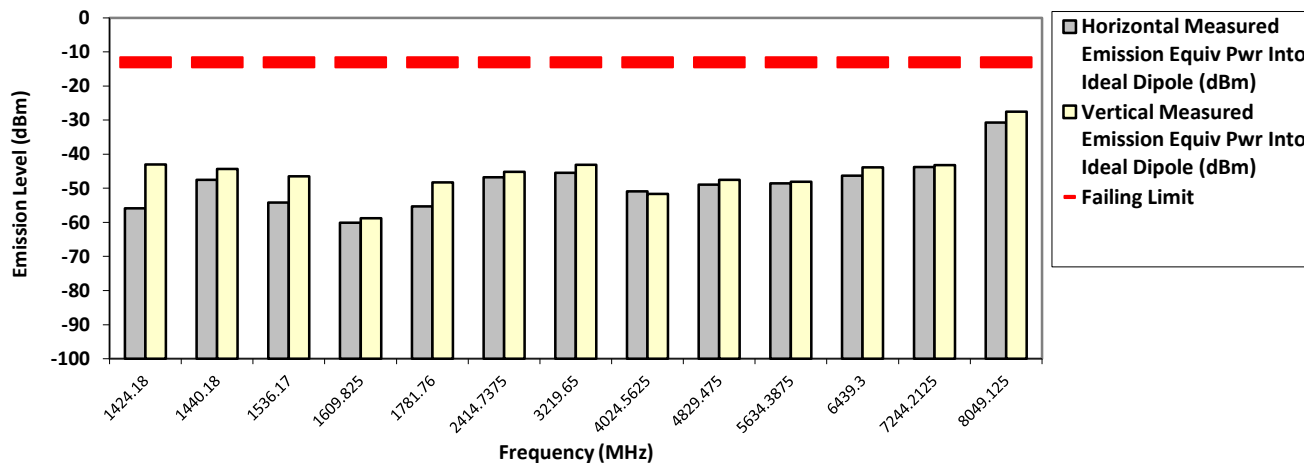

The data presented here was taken using the substitution method as found in the ANSI C63.26-2015 document.
 Motorola Penang EMC Lab - Test Performed by: Nazrin&Qawiman Sun, Apr 29, 2018

Remarks: ** Indicates the spurious emission could not be detected due to noise limitations or ambient.

*Pursuant to CFR 47 Part 2.1057 (c), emissions attenuated more than 20 dB below the permissible limit are not reported
 Temp(Deg): 22.6 Hum(%RH): 70.3

System MU: 5.01 dB

Remarks: Passed Results Marginal Results Failed Results

SAC Transmitter Radiated Emission:

Model Number: M37TXS9PW1AN **S/N: 681P3A0078** **SR:08878-EMC-00004**
Battery Part No: NA **Accy Part No: 3466-HMN1079G-3,**
3466-HKN6163C-1, 254-HKN6170B-02, 1187-HKN6188B-1, 1187-PMHN4194A-1
Test Mode: TX APCO Digital Phase II

804.912500 MHz **12.5 kHz** **1.000 Watt(s) /Low Power**

Frequency (MHz)	Limit	Horizontal Measured Emission Equip Pwr Into Ideal Dipole (dBm)	Vertical Measured Emission Equip Pwr Into ideal Dipole (dBm)
1424.1800	-13.0000	-55.6500 *	-43.3100 *
1456.1800	-13.0000	-56.0400 *	-39.6900 *
1535.7700	-13.0000	-49.5600 *	-52.3500 *
1609.8250	-13.0000	-61.7380 **	-59.6904 **
2414.7375	-13.0000	-57.7010 **	-57.7392 **
3219.6500	-13.0000	-53.4568 **	-52.7990 **
4024.5625	-13.0000	-51.3282 **	-52.8306 **
4829.4750	-13.0000	-50.0953 **	-49.7803 **
5634.3875	-13.0000	-48.5863 **	-48.0045 **
6439.3000	-13.0000	-45.7356 **	-44.8685 **
7244.2125	-13.0000	-44.6027 **	-46.1445 **
8049.1250	-13.0000	-45.5513 **	-44.8129 **

RADIATED SPURIOUS EMISSIONS

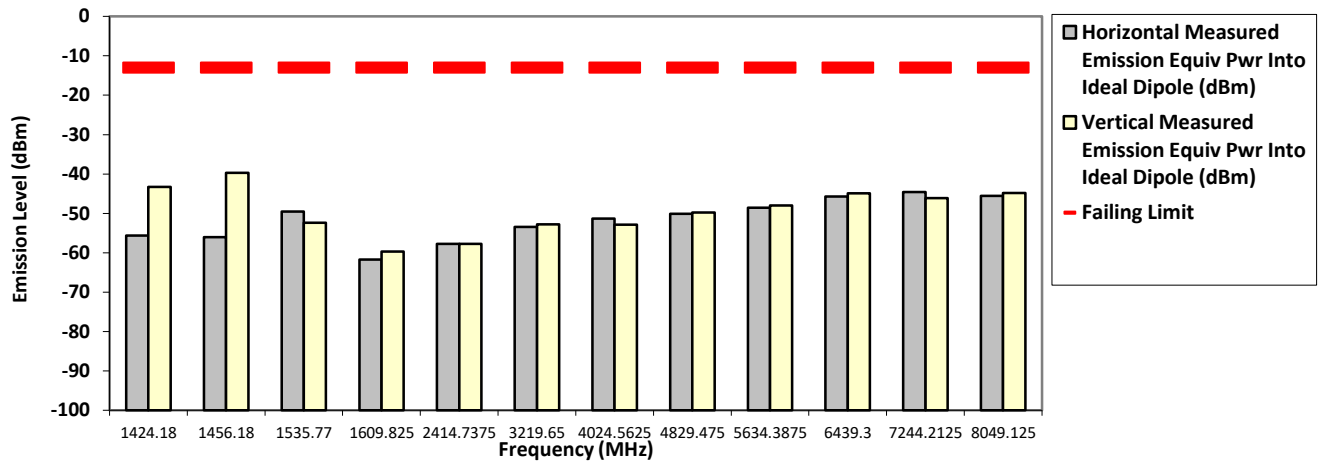

The data presented here was taken using the substitution method as found in the ANSI C63.26-2015 document.
 Motorola Penang EMC Lab - Test Performed by: Nazrin&Qawiman Mon, Apr 30, 2018

Remarks: ** Indicates the spurious emission could not be detected due to noise limitations or ambient.

*Pursuant to CFR 47 Part 2.1057 (c), emissions attenuated more than 20 dB below the permissible limit are not reported
 Temp(Deg): 22.6 Hum(%RH): 70.3

System MU: 5.01 dB

Remarks:

Passed Results	Marginal Results	Failed Results
----------------	------------------	----------------

6.11.4. Test Limit

Table below summarized the power of any emission outside a licensee’s frequency block shall be attenuated below the transmitter power (P) by at least

Channel Spacing	Part 22	Part 24D	Part 74	Part 80	Part 90 (UHF, VHF, 800, 900)	Part 90 (700)
12.5kHz	43 + log10(P) (-13 dBm)	43 + log10(P) (-13 dBm)	43 + log10(P) (-13 dBm)	Not Applicable	50 + log10(P) (-20 dBm)	43 + log10(P) (-13 dBm)
25kHz		Not Applicable		43 + log10(P) (-13 dBm)	43 + log10(P) (-13 dBm)	43 + log10(P) (-13 dBm)

Channel Spacing	RSS 134	RSS 182	RSS 119 (UHF, VHF, 800, 900)	RSS 119 (700)
12.5kHz	43 + log10(P) (-13 dBm)	Not Applicable	50 + log10(P) (-20 dBm)	43 + log10(P) (-13 dBm)
25kHz	Not Applicable	43 + log10(P) (-13 dBm)	43 + log10(P) (-13 dBm)	43 + log10(P) (-13 dBm)

6.12. Effective Radiated Power (ERP)

6.12.1. Test Setup

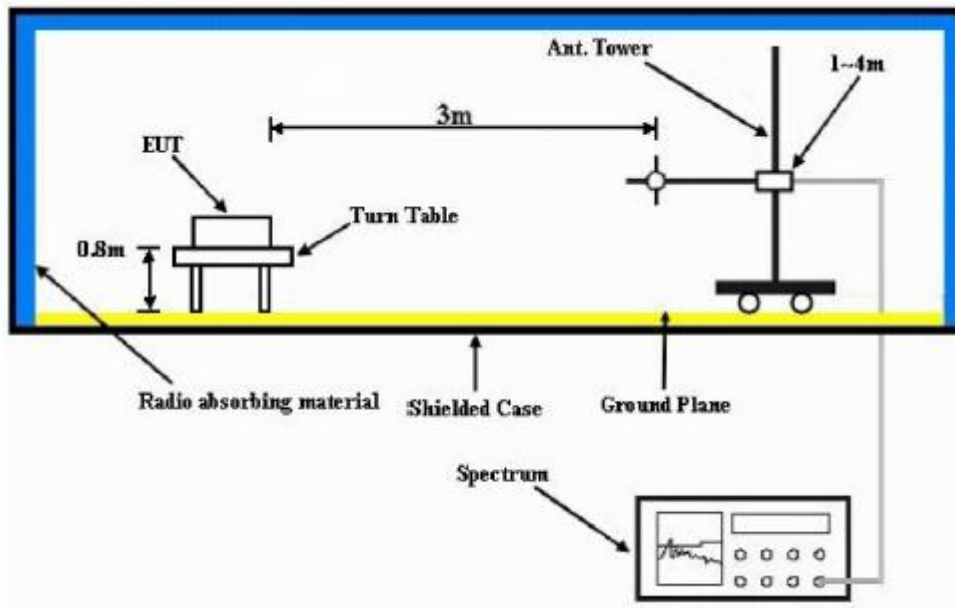

- 1) The Resolution Bandwidth for Equivalent Radiated Power (ERP) below 1 GHz is 100 kHz with Video Bandwidth = 300 kHz and Resolution Bandwidth for EIRP above 1 GHz is 1 MHz with Video Bandwidth = 3 MHz. Detector Mode is RMS.
- 2) In the semi-anechoic chamber, setup as illustrated above the DUT placed on the 0.8m height of Turn Table, rotated the table 45 degree each interval to search the maximum radiation power and receiver antenna shall be rotated vertical and horizontal polarization and moved height from 1m to 4m to find the maximum polar radiated power for each degree interval. The “Read Value” is the spectrum reading of maximum power value.
- 3) The substitution antenna is substituted for DUT at the same position and signals generator (S.G) export the CW signal to the substitution antenna via a TX cable. The receiver antenna shall be rotated vertical and horizontal polarization and moved height from 1m to 4m to find the maximum radiation power. Record the power level of maximum radiation power from spectrum. So, the Measured substitution value = Ref level of S.G + TX cables loss – Substituted Antenna Gain.

6.12.2. Test Result

6.12.3. Test Limit

The maximum output power of the transmitter for mobile stations is 100 watts (20 dB). Power is given in terms of effective radiated power (ERP).

6.13. GNSS (EIRP for 1559 - 1610MHz)

6.13.1. Test Setup

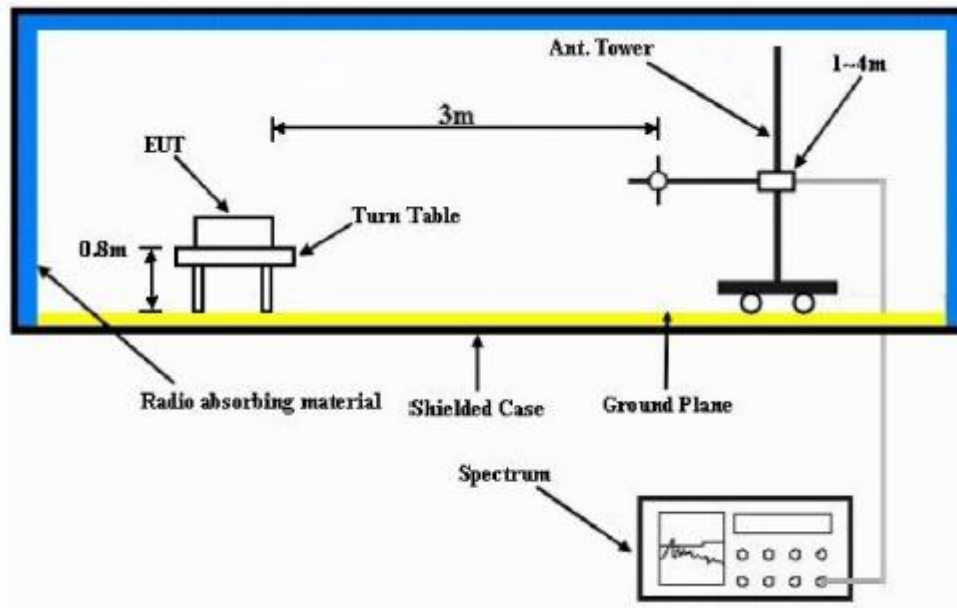

- 4) The Resolution Bandwidth for Equivalent Isotropically Radiated Power (EIRP) below 1 GHz is 100 kHz with Video Bandwidth = 300 kHz and Resolution Bandwidth for EIRP above 1 GHz is 1 MHz with Video Bandwidth = 3 MHz. Detector Mode is RMS.
- 5) In the semi-anechoic chamber, setup as illustrated above the DUT placed on the 0.8m height of Turn Table, rotated the table 45 degree each interval to search the maximum radiation power and receiver antenna shall be rotated vertical and horizontal polarization and moved height from 1m to 4m to find the maximum polar radiated power for each degree interval. The “Read Value” is the spectrum reading of maximum power value.
- 6) The substitution antenna is substituted for DUT at the same position and signals generator (S.G) export the CW signal to the substitution antenna via a TX cable. The receiver antenna shall be rotated vertical and horizontal polarization and moved height from 1m to 4m to find the maximum radiation power. Record the power level of maximum radiation power from spectrum. So, the Measured substitution value = Ref level of S.G + TX cables loss – Substituted Antenna Gain.
- 7) $EIRP = \text{“Read Value”} + \text{Measured substitution value} + 2.15$.

6.13.1. Test Result

Date:	07/05/2018	EMC#:	08878-EMC-00021		
Product:	APX8500 ALL BAND (7/800, VHF, UHF) MOBILE	S/N	681P3A0078	Channel Spacing: 12.5kHz	
		Notes:	1. HAF4013A	GNSS	
Tx Freq.	799.0875				
		Horizontal Radiated	Vertical Radiated		
	Frequency	Spur. Emiss.	Spur. Emiss.		
Spur	MHz	(dBW/MHz)	(dBW/MHz)		
2XFund	1598.175	-76.84	-70.89		
		Notes:	2. HAF4013A	GNSS	
Tx Freq.	804.9125				
		Horizontal Radiated	Vertical Radiated		
	Frequency	Spur. Emiss.	Spur. Emiss.		
Spur	MHz	(dBW/MHz)	(dBW/MHz)		
2XFund	1609.8250	-88.89	-81.06		
		Notes:	3.	GNSS	
Tx Freq.					
		Horizontal Radiated	Vertical Radiated		
	Frequency	Spur. Emiss.	Spur. Emiss.		
Spur	MHz	(dBW/MHz)	(dBW/MHz)		
2XFund					

Remarks:* Indicates the unwanted spurious emission could not be detected due to noise limitations or ambients.

6.13.2. Test Limit

For operations in the 758-775 MHz and 788-805 MHz bands, all emissions including harmonics in the band 1559-1610 MHz shall be limited to -70 dBW/MHz equivalent isotropically radiated power (EIRP) for wideband signals, and -80 dBW EIRP for discrete emissions of less than 700 Hz bandwidth.

~ End of Report ~