



VRS 750
Vehicular Repeater System
Detailed Service Manual

Foreword

The information contained in this manual relates to the VRS750 Vehicular Repeater System, unless otherwise specified. This manual provides sufficient information to enable service shop personnel to troubleshoot and repair the VRS750 to the component level.

Safety Information

Before operating the VRS750, please read the “User Safety, Training, and General Information” section in the front of this manual.

Manual Revisions

Changes which occur after this manual is printed are described in “FMRs.” These FMRs provide complete information on changes, including pertinent parts list data.

Computer Software Copyrights

The Motorola products described in this manual may include copyrighted Motorola computer programs stored in semiconductor memories or other media. Laws in the United States and other countries preserve for Motorola certain exclusive rights for copyrighted computer programs, including, but not limited to, the exclusive right to copy or reproduce in any form the copyrighted computer program. Accordingly, any copyrighted Motorola computer programs contained in the Motorola products described in this manual may not be copied, reproduced, modified, reverse-engineered, or distributed in any manner without the express written permission of Motorola. Furthermore, the purchase of Motorola products shall not be deemed to grant either directly or by implication, estoppel, or otherwise, any license under the copyrights, patents or patent applications of Motorola, except for the normal non-exclusive license to use that arises by operation of law in the sale of a product.

Table of Contents



Foreword	inside front cover
User Safety, Training, and General Information	iii
Safe Handling of CMOS Integrated-Circuit Devices	vi
Model Chart for the VRS750	vii
VHF VRS750 Performance Specifications	viii
UHF VRS750 Performance Specifications	viii
Glossary of Terms	ix
List of Abbreviations and Acronyms	x
1 - Introduction	1
Description	1
Ordering Information	2
VRS Features	3
Mutually-Exclusive Features	3
2 - Installation	5
VRS Installation	5
Installation of the Mounting Trunnion	6
VRS Antenna Installation	7
VRS750 Programming	7
3 - VRS Operation	19
General	19
Control Unit	19
Vehicle Interface Ports	20
VRS Access	20
In-Car Monitor	20
Mobile Audio Repeat	21
4 - Operation of VRS Options	23
Base Repeater	23
Mobile Detector	23
VRS Transmit PL Generator	23

Ⓜ, Private Line, and Motorola are registered trademarks of Motorola Inc.

Systems 9000, ASTRO, Spectra, Call Alert, Private Conversation, Single Tone, Digital Private-Line, and Slimnet are trademarks of Motorola Inc.

Torx is a trademark of Camcar Div. of Textron, Inc.

VRS Mode Steering	23
Time-Out Timer	26
VRS Single Tone	26
VRS Mobile-TX Acknowledgment Tones (Conventional Only)	27
Flashing Display	27
Repeater PPI	27
Quick-Key	27
5 - Detailed VRS Operation	29
Multi-VRS Operation	29
Rptr PPI—Portable Priority Interrupt	34
TX PL Self-Clearing	36
ICM Functions	37
Acknowledgment Tones	38
Non-Priority VRS Rules	40
Emergency	41
6 - Hardware Detailed Theory of Operation	43
Power Regulation	43
Bus Translation Circuitry	43
Audio Routing Circuitry	44
Single Tone Encoder	45
Single Tone Decoder	45
Boot Control Circuitry	45
Program Sense	46
Mode Configuration	46
7 - Maintenance and Troubleshooting	49
Troubleshooting Procedures	49
Disassembly and Reassembly Procedures	51
VRS Transceiver	56
VRS Tuning and Alignment	56
8 - Troubleshooting Charts	67
List of Troubleshooting Charts	67
9 - Diagrams and Parts Lists	81
List of Diagrams and Parts Lists	81

User Safety, Training, and General Information

READ THIS IMPORTANT INFORMATION ON SAFE AND EFFICIENT OPERATION BEFORE INSTALLING AND USING YOUR MOTOROLA MOBILE TWO-WAY RADIO IN A VEHICLE OR AS A CONTROL STATION.

Compliance with RF Energy Exposure Standards

Your Motorola two-way radio is designed and tested to comply with a number of national and international standards and guidelines (listed below) regarding human exposure to radio frequency electromagnetic energy. **This radio complies with the IEEE (FCC) and ICNIRP exposure limits at duty cycles of up to 50% talk-50% listen and should be used for occupational use only.** In terms of measuring RF energy for compliance with the FCC exposure guidelines, your radio radiates measurable RF energy only while it is transmitting (during talking), not when it is receiving (listening) or in standby mode.

Your Motorola two-way radio complies with the following RF energy exposure standards and guidelines:

- United States Federal Communications Commission, Code of Federal Regulations; 47CFR part 2 subpart J
- American National Standards Institute (ANSI) / Institute of Electrical and Electronic Engineers (IEEE) C95. 1-1992
- Institute of Electrical and Electronic Engineers (IEEE) C95.1-1999 Edition
- International Commission on Non-Ionizing Radiation Protection (ICNIRP) 1998
- Ministry of Health (Canada) Safety Code 6. Limits of Human Exposure to Radiofrequency Electromagnetic Fields in the Frequency Range from 3 kHz to 300 GHz, 1999
- Australian Communications Authority Radiocommunications (Electromagnetic Radiation - Human Exposure) Standard 1999 (applicable to wireless phones only)

Operational Instructions and Training Guidelines

To ensure optimal performance and compliance with the RF energy exposure limits in the above standards and guidelines, users should transmit no more than 50% of the time and always adhere to the following procedures:

Transmit and Receive

- To transmit (talk), push the Push-To-Talk (PTT) button; to receive, release the PTT button.
- Transmit only when people outside the vehicle are at least the minimum lateral distance away, as shown in Table 1, from a properly installed, externally-mounted antenna.

Table 1 lists the minimum lateral distance for bystanders in an uncontrolled environment from the transmitting antenna at several different ranges of rated radio power for mobile radios installed in a vehicle.

Table 1. Rated Power and Lateral Distance

Rated Power of Vehicle-Installed Mobile Two-Way Radio	Minimum Lateral Distance from Transmitting Antenna
Less than 7 watts	8 inches (20 centimeters)
7 to 15 watts	1 foot (30 centimeters)
16 to 50 watts	2 feet (60 centimeters)
51 to 110 watts	3 feet (90 centimeters)

Mobile Antennas

- Install antennas at the center of the roof or the center of the trunk deck. These mobile antenna installation guidelines are limited to metal body vehicles.
- The antenna installation must additionally be in accordance with:
 - a. The requirements of the antenna manufacturer/supplier
 - b. Instructions in the Radio Installation Manual
- Use only Motorola approved supplied antenna or Motorola approved replacement antenna. Unauthorized antennas, modifications, or attachments could damage the radio and may violate FCC regulations.

Approved Accessories

For a list of Motorola approved antennas see the appendix of this user manual.

Fixed Site Antennas

If mobile radio equipment is installed at a fixed location and operated as a control station or as a fixed unit, the antenna installation must comply with the following requirements in order to ensure optimal performance and compliance with the RF energy exposure limits in the above standards and guidelines.

- The antenna should be mounted outside the building on the roof or a tower if at all possible.
- As with all fixed site antenna installations, it is the responsibility of the licensee to manage the site in accordance with applicable regulatory requirements and may require additional compliance actions such as site survey measurements, signage, and site access restrictions in order to insure that exposure limits are not exceeded.

Electromagnetic Interference/Compatibility

NOTE: Nearly every electronic device is susceptible to electromagnetic interference (EMI) if inadequately shielded, designed or otherwise configured for electromagnetic compatibility. It may be necessary to conduct compatibility testing to determine if any electronic equipment used in or around vehicles or near fixed antenna sites is sensitive to external RF energy and if any procedures need to be followed to eliminate or mitigate the potential for interaction between the radio transmitter and the equipment or device.

Facilities

To avoid electromagnetic interference and/or compatibility conflicts, **turn off your radio in any facility where posted notices instruct you to do so.** Hospitals or health care facilities may be using equipment that is sensitive to external RF energy.

Vehicles

To avoid possible interaction between the radio transmitter and any vehicle electronic control modules, for example, ABS, engine, or transmission controls, we recommend that the radio be installed by an experienced installer and that the following precautions be used when installing the radio:

1. Refer to any manufacturers instructions or other technical bulletins or recommendations on radio installation.
2. Before installing the radio, determine the location of the electronic control modules and their harnesses in the vehicle.
3. Route all radio wiring, including the antenna transmission line, as far away as possible from the electronic control units and associated wiring.

Driver Safety

Check the laws and regulations on the use of radios in the area where you drive. Always obey them.

When using your radio while driving, please:

- Give full attention to driving and to the road.
- Pull off the road and park before making or answering a call if driving conditions so require.

Operational Warnings



WARNING

For Vehicles With an Air Bag

Do not place a portable or mobile radio in the area over an air bag or in the air bag deployment area. Air bags inflate with great force. If a radio is placed in the air bag deployment area and the air bag inflates, the radio may be propelled with great force and cause serious injury to occupants of the vehicle.

Potentially Explosive Atmospheres

Turn off your radio prior to entering any area with a potentially explosive atmosphere. Sparks in a potentially explosive atmosphere can cause an explosion or fire resulting in bodily injury or even death.

The areas with potentially explosive atmospheres referred to above include fueling areas such as below decks on boats, fuel or chemical transfer or storage facilities, areas where the air contains chemicals or particles, such as grain, dust or metal powders, and any other area where you would normally be advised to turn off your vehicle engine. Areas with potentially explosive atmospheres are often but not always posted.

Blasting Caps and Blasting Areas

To avoid possible interference with blasting operations, turn off your radio when you are near electrical blasting caps, in a blasting area, or in areas posted: "Turn off two-way radio." Obey all signs and instructions.

For radios installed in vehicles fuelled by liquefied petroleum gas, refer to the (U.S.) National Fire Protection Association standard, NFPA 58, for storage, handling, and/ or container information. For a copy of the LP-gas standard, NFPA 58, contact the National Fire Protection Association, One Battery Park, Quincy, MA.

Safe Handling of CMOS Integrated-Circuit Devices

Many of the integrated-circuit (IC) devices used in communications equipment are of the CMOS (Complementary Metal Oxide Semiconductor) type. Because of their high open-circuit impedance, CMOS ICs are vulnerable to damage from static charges. Everyone involved in handling, shipping, and servicing them must be extremely careful not to expose them to such damage.

CMOS ICs do have internal protection, but it is effective only against overvoltages in the hundreds of volts, such as those that could occur during normal operations. Overvoltages from static discharge can be in the thousands of volts.

When a CMOS IC is installed in a system, the circuit elements in the system distribute static charges and load the CMOS circuits. This decreases the vulnerability of the ICs to static discharge, but improper handling will probably cause static damage even when the ICs are so installed.

To avoid damaging CMOS ICs, take the following precautions when handling, shipping, and servicing them.

1. Before touching a circuit module, particularly after having moved around in the service area, touch both hands to a bare-metal, earth-grounded surface. This discharges any static charge you may have accumulated.

NOTE: Wear a conductive wrist strap (Motorola part number RSX-4015A) to minimize the buildup of static charges on your person while you are servicing CMOS equipment.



When wearing a conductive wrist strap, be careful near sources of high voltage. By grounding you thoroughly, the wrist strap also increases the danger of lethal shock from accidental contact with such a source.

WARNING

2. Whenever possible, avoid touching any electrically conductive parts of the circuit module with your hands.
3. Check the INSTALLATION and MAINTENANCE sections of this manual and the notes on the schematic to find out whether or not you can insert or remove circuit modules with power applied to the unit, and act accordingly.
4. When servicing a circuit module, avoid carpeted areas, dry environments, and the wearing of static-generating clothing.
5. Be sure that all electrically powered test equipment is grounded. Attach the ground lead from the test equipment to the circuit module before connecting the test probe. Similarly, disconnect the test probe before removing the ground lead.
6. When you remove a circuit module from the system, lay it on a sheet of aluminum foil or other conductive surface connected to ground through 100,000 ohms of resistance.



If the aluminum foil is connected directly to ground, you may get a shock if you touch it and another electrical circuit at the same time.

WARNING

7. When soldering, be sure the soldering iron is grounded.
8. Before connecting jumpers, replacing circuit components, or touching CMOS pins (if this becomes necessary during the replacement of an integrated-circuit device), be sure to discharge any static buildup on your person (see step 1, above). Because you can have a voltage difference across your body, you should use only one hand if you must touch the board wiring or any of the pins on the CMOS device.
9. When replacing a CMOS integrated-circuit device, leave the device in its metal rail container or conductive foam until you are ready to insert it into the pronged circuit module.
10. Connect any low-impedance test equipment, such as a pulse generator, to CMOS device inputs after you have applied power to the CMOS circuitry. Similarly, disconnect such low-impedance equipment before turning off the power.
11. Wrap CMOS modules in conductive material when transporting them from one area to another, even within the same room. Use wrapping material similar to that in which replacement modules are wrapped when they arrive from the factory. (You can also use aluminum foil.) Never use nonconductive material for packaging these modules.

Model Chart for the VRS750

MODEL NUMBER				DESCRIPTION
P2080				VRS750 VHF (136-174 MHz)
P2081				VRS750 UHF R1 (403-470 MHz)
P2082				VRS750 UHF R2 (450-512 MHz)
ITEM NUMBER				DESCRIPTION
X	X	X	HHN4044*	VRS750 Housing
X	X	X	HLN6855*	VRS750 Mounting Assembly
X	X	X	PLN7780†	VRS750 Controller Board
X	X	X	HLN6856*	XCVR Hardware
X			PMLD4196	VHF Transceiver
	X		PMLE4242	UHF R1 Transceiver
		X	PMLE4243	UHF R2 Transceiver
X	X	X	HKN6153	Cable, Mobile-to-VRS
1	1	1	HKN6154	Cable, Siren-to-VRS
2	2	2	6881094C84	VRS750 Detailed Service Manual
X	X	X	2884606M01	Mini-UHF crimp connector
X	X	X	YLN4480	VRS Pushbutton
X	X	X	HBN5086	Packing Kit
			3085031D02	Cable, VRS Programming (accessory)
			NTN4056	Adapter, VRS Flash programming (accessory)
			NKN6460	y-cable kit for dual controlhead w/vrs (accessory)
			TLN5277	DC filter for excessive alternator whine (accessory)
			RLN5394	VRS750 Test Box (accessory)
			3080384N02	VRS750 ATE Cable (accessory)

1 = With option G334AC. Deletes HKN6153 cable.

2 = One item per 10 units.

*For piece part information, refer to the Exploded View section.

†For piece part information, refer to the Electrical Parts List section.

VHF Performance Specifications

GENERAL		TRANSMITTER	RECEIVER
Model	P2080 (136-174 MHz)†	RF Power Out: 275 mW to 2 W tunable	Intermodulation per EIA: 70 dB
Number of Channels:	1, T1 = R1	Spurious and Harmonic Emissions: -36 dBm < 1 GHz -30 dBm > 1 GHz	Hum and Noise: -40dBm @ 25 kHz -35dBm @ 12.5 kHz
Frequency:	Programmable, Synthesized Frequency Channel	Frequency Stability: ±2.5 ppm @ 25 kHz ±2.5 ppm @ 12.5 kHz	Reference Sensitivity (typical): 0.28 µV (-118dBm) at 12 dB SINAD
Channel Spacing:	12.5/20/25 kHz	Modulation Limiting (Max): ±2.5 kHz @ 12.5 kHz ±4.0 kHz @ 20 kHz ±5.0 kHz @ 25 kHz	Conducted Spurious Rejection: 70 dB
Operation Temp. Range:	-30°C to +60°C	Audio Response: (from 6 dB/octave pre-emphasis, 300 to 3000 Hz) +1, -3 dB	Adjacent Channel Selectivity: 60 dB @ 12.5 kHz 70 dB @ 25/30 kHz
Primary Power:	13.8 VDC ± 20%, Negative Ground	Audio Distortion: 3% Typical @ 1 kHz, 60% maximum deviation	Audio Response (0.3-3 kHz): +1 to -3 dB
DC Current Drain (max):	120 mA Receive 500 mA Transmit @ 275 mW 1.10 A Transmit @ 2 W	FM Hum and Noise: -40 dB	Audio Distortion: 3% Typical @ Mobile Rated Audio*
Squelch Operation:	Private-Line required for repeater access	TX Attack Time: 32 ms Typical	Conducted Spurious Emissions: -57 dBm < 1 GHz -47 dBm > 1 GHz
Duty Cycle:	Intermittent per EIA at 275 mW	Antenna Impedance: 50 ohms	RX Attack Time: 60 ms Typical
PPI Sample Time:	16 ms Typical	Antenna Connector: mini-uhf	
Singletone Encoder/Decoder:	Nominal 847.5 Hz		
FCC Identifiers:	AZ492FT3802 (P2080)		
Industry Canada:			

*Typically 5 W in 8 ohms.

†Consult the product catalog sheets (ECAT Price Pages) for a list of disallowed frequencies.

UHF Performance Specifications

GENERAL		TRANSMITTER	RECEIVER
Model	P2081 (403-470 MHz) P2082 (450-512 MHz)†	RF Power Out: 275 mW to 2 W tunable	Intermodulation per EIA: 70 dB
Number of Channels:	1, T1 = R1	Spurious and Harmonic Emissions: -36 dBm < 1 GHz -30 dBm > 1 GHz	Hum and Noise: -40dBm @ 25 kHz -35dBm @ 12.5 kHz
Frequency:	Programmable, Synthesized Frequency Channel	Frequency Stability: ±2.5 ppm @ 25 kHz ±2.5 ppm @ 12.5 kHz	Reference Sensitivity (typical): 0.28 µV (-118 dBm) at 12 dB SINAD
Channel Spacing:	12.5/20/25 kHz	Modulation Limiting (Max): ±2.5 kHz @ 12.5 kHz ±4.0 kHz @ 20 kHz ±5.0 kHz @ 25 kHz	Conducted Spurious Rejection: 70 dB
Operation Temp. Range:	-30°C to +60°C	Audio Response: (from 6 dB/octave pre-emphasis, 300 to 3000 Hz) +1, -3 dB	Adjacent Channel Selectivity: 60 dB @ 12.5 kHz 70 dB @ 25/30 kHz
Primary Power:	13.8 VDC ± 20%, Negative Ground	Audio Distortion: 3% Typical @ 1 kHz, 60% maximum deviation	Audio Response (0.3-3 kHz): +1 to -3 dB
DC Current Drain (max):	120 mA Receive 700 mA Transmit @ 275 mW 1.20 A Transmit @ 2 W	FM Hum and Noise: -40 dB	Audio Distortion: 3% Typical @ Mobile Rated Audio*
Squelch Operation:	Private-Line required for repeater access	TX Attack Time: 14 ms Typical	Conducted Spurious Emissions: -57 dBm < 1 GHz -47 dBm > 1 GHz
Duty Cycle:	Intermittent per EIA at 275 mW	Antenna Impedance: 50 ohms	RX Attack Time: 60 ms Typical
PPI Sample Time:	16 ms Typical	Antenna Connector: mini-uhf	
Singletone Encoder/Decoder:	Nominal 847.5 Hz		
FCC Identifiers:	AZ492FT4848 (P2081) AZ492FT4849 (P2082)		
Industry Canada:			

*Typically 5 W in 8 ohms.

†Consult the product catalog sheets (ECAT Price Pages) for a list of disallowed frequencies.

Glossary of Terms

The following glossary of terms and definitions help you to understand the VRS theory of operation.

Countdown	A term that describes the incremental step-down function of the counter in the repeater. Approximately 500 milliseconds of time delay for conventional modes and 1500 milliseconds for trunked modes separate each successive delay state.
Delay State	The specific condition of the counter. A series of eight delay states prioritize the repeaters within a common geographical area. Delay state zero has the least time delay (0 milliseconds); delay state seven has the greatest delay (approximately 3.5 seconds for conventional modes, and 10.5 seconds for trunked modes). A unit that is in delay state zero is the priority unit.
Disable	The deactivation of the repeater. Press the VRS button on the control head or switch the VIP input off.
Enable	The activation of the repeater. Press the VRS button on the control head or switch the VIP input on.
Inhibit	A condition that occurs when the countdown sequence of the logic circuitry of the repeater ends, or anytime the repeater stops transmitting.
Non-Priority Repeater	A repeater in any delay state other than delay state zero. This unit is inactive and does not repeat until the unit steps down to delay state zero.
PTT	The Push-To-Talk button on a portable radio or mobile microphone.
Priority Repeater	A repeater with its counter in delay state zero. This unit repeats any signal with the proper carrier frequency and PL code.
Quick-Key	A short press of the portable's PTT—one that is long enough for the VRS to key the mobile and access the trunking system, but less than 1 second in duration.
Single Tone Burst	When a repeater enables, it transmits a 700-millisecond audible tone. This tone burst increases the delay counter in all other repeaters within range of the transmitting vehicle by one delay increment.

List of Abbreviations and Acronyms

B-P	Base to Portable
CPS	Customer Programming Software
DPL	Digital Private Line
HUB	Hang Up Box
ICM	In Car Monitor
ms	Millisecond
PAC	Portable Area Coverage
PL	Private Line
PPI	Portable Priority Interrupt
P-B	Portable to Base
RF	Radio Frequency
RX	Receive
SB	Serial Bus
SBEP	Serial Bus Expanded Protocol
TOT	Time Out Timer
TX	Transmit
VIP	Vehicle Interface Port
VRS	Vehicular Repeater System
VRS-EP	Vehicular Repeater System—Expanded Protocol
VRS750	Vehicular Repeater System—Model 750

Introduction

1

Description

The VRS750 Vehicular Repeater System is a mobile radio system component that provides on-site repeater capability between a portable radio and a base station (see Figure 1). The VRS gives the portable user the equivalent range of a mobile radio with the flexibility of a portable. The VRS is not an ASTRO-capable radio; instead, it is designed to *interface* with an ASTRO Spectra® mobile radio. It can only transmit and receive clear analog transmissions.

The VRS receives transmissions on the portable radio's transmit frequency with the proper access PL, and passes these portable signals to the mobile radio. The mobile radio re-transmits the signals to the base station on the mobile radio's transmit frequency.

NOTE: These transmissions have the mobile's ID, not the portable's.

Similarly, base station signals received by the mobile radio are sent to the VRS and re-transmitted to the portable radio. The VRS does not provide local repeater capability (received portable signals are not repeated on the portable receive frequency).

The VRS-to-portable and portable-to-VRS communications are limited to clear analog only. This is a simplex-only interface; the VRS cannot receive and transmit simultaneously. The base station-to-mobile and mobile-to-base communications protocol is not limited to analog only. Rather, this interface is limited by the features and functions of the ASTRO Spectra and the base.

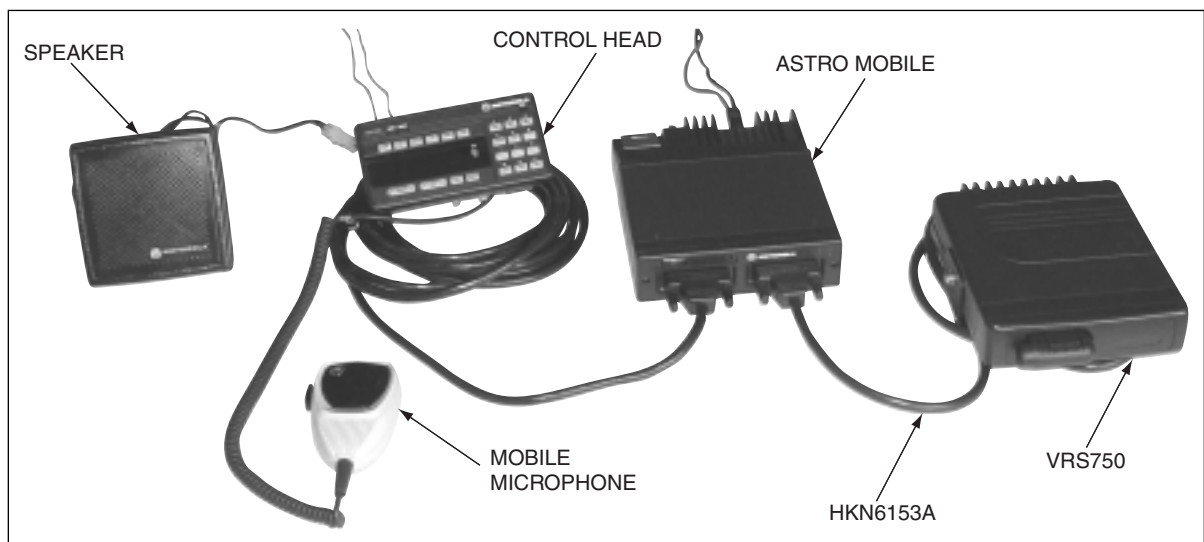

Figure 1. VRS750 Vehicular Repeater System

Ordering Information

The VRS is a crossband repeater that operates on either UHF or VHF frequencies. The repeater cannot be operated with a mobile radio operating in the same band as the VRS unit.

The VRS RF platform is based on a synthesized transceiver. The VRS supports one channel whose frequency and channel spacing can be programmed in the field. The VRS remains a simplex repeater and as a result, the transmit frequency must be set equal to the receive frequency. The VRS receives its programming information from the ASTRO Spectra mobile at power-up. The ASTRO Spectra mobile supports the VRS programming fields via ASTRO Customer Programming Software (CPS). For more information, refer to “VRS750 Programming,” in Chapter 2, “Installation.”

The VRS is not compatible with ASTRO Spectra mobiles with the VSELP signaling type.

When integrating a VRS with an ASTRO mobile with a Siren/PA, an alternate interface cable is needed (HKN6154A). This cable allows the VRS to be connected to the Siren/PA. For more information, refer to “Installation,” Chapter 2.

When integrating a VRS with an ASTRO mobile with Dual Control heads, an alternate interface cable is needed (NKN6460A). This y-cable allows the VRS to be connected to the ASTRO mobile with two control heads.

A separate antenna (not included) is necessary for use with the repeater. Typically, a one-quarter (1/4) wave length antenna maximizes radiation efficiency when installed at the center of the vehicle roof. If it is necessary to mount the antenna on the vehicle's trunk lid, an appropriate 3 dB gain antenna should be used. See “VRS Antenna Installation,” in Chapter 2, for details.

A filter for the battery lines (TLN5277B) is available for use with ASTRO Spectra mobiles. This filter can be used to prevent excessive alternator whine noise from being heard on the mobile speaker during VRS operation.

The VRS ships from the factory with the low output power setting at 275 mW and a high output power setting of 2 W. The low output power setting is the default setting. We recommend the LOW Transmit Power setting of 275 mW for optimal performance. This output power provides the VRS with a similar range as the portable when attached to a mobile antenna. Any deviation from this setting could result in a loss of communication from the portable to the base.

The Global Tuning Tool (not included) can be used to tune the VRS output power in the field. For more information refer to “VRS750 Global Tuner,” in Chapter 2.

Contact Customer Resources for information on how to obtain this Global Tuning Tool.

VRS Features

The VRS operates with the ASTRO mobile radio and contains the following integrated features:

- Automatic, multiple-unit, priority-resolution algorithm.
- Portable priority interrupt (PPI) function.
- Conventional/trunked operation.
- Remote switch enable/disable capability for control charger interface.
- Remote activation of emergency alarm feature.
- In-car monitor operation.
- VRS mobile access tones.
- Mobile radio transmitter steering of up to eight modes via Private-Line® (PL) code transmission from the portable radio.
- TX PL generator.
- Base repeater operation for two-frequency, simplex, fixed-repeater systems.
- Mobile audio repeat.
- Compatible with the VRS-EP.

All VRS features can be programmed in the field using ASTRO Spectra mobile CPS. For more information, refer to “VRS750 Programming,” in Chapter 2.

IMPORTANT NOTE: All ASTRO Spectra VRS systems with the same VRS RF transmit/receive frequency need to be CPS programmed identically to ensure proper operation. Failure to do so could result in erratic system operation.

The VRS does not have to be installed in the system for programming—only the mobile radio is programmed. If the VRS is not connected after programming the mobile system, an error message “ERR 12/10” will be displayed on the control head.

Mutually-Exclusive Features

The VRS IS NOT compatible with the following mobile radio features:

- W3 Control Head is not supported with VRS
- Flush-mounted control heads
- VSELP signaling type
- Data—VRS and data are not compatible on the same channel and cannot be used simultaneously. VRS should never be activated on a channel that has packet data enabled, and VRS mode steering channels should not have packet data enabled.
- Scan
- Over-the-Air Rekeying (OTAR) Rekey Request

- Message (from the Control Head)—Trunking or Conventional
- Status (from the Control Head)—Trunking or Conventional
- Emergency Call—Trunking or Conventional—Emergency Call and VRS are mutually exclusive. Even if the mobile is programmed for Alarm and Call, when the Alarm case is exited, the mobile will not transition into Emergency Call while the VRS is activated. Likewise, if the mobile is in Emergency Call, the VRS cannot be activated.

NOTE: When an Emergency Alarm is received, the dispatcher may elevate that talkgroup to Emergency status.

- Reprogram Request—Trunking
- Repeater Access Control—Conventional
- Mobile Single Tone—Conventional
- Seven-Tone Modat—Conventional
- Motorcycle
- Consolette (Digital Remote and Tone Remote)

The following mobile radio features may be received but may not be initiated or responded to while VRS is enabled.

- Private Conversation™—Trunking
- Call Alert™—Trunking or Conventional
- Telephone Interconnect—Trunking or Conventional
- Voice Selective Call—Conventional

Installation

2

When selecting the location for the VRS, make certain that there is sufficient clearance for routing the antenna cable to the rear of the unit.

VRS Installation

The VRS750 is installed using the HKN6153A interface cable. The molded DB-25 end connects to the ASTRO mobile front connector. The DB-25 end with the plastic housing connects to the VRS (see Figure 2).

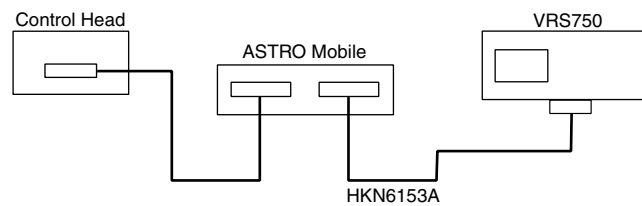

Figure 2. Installing the VRS to an ASTRO Mobile

If an external Siren/PA is to be used, the G334AC option must be ordered which replaces the HKN6153A cable with a HKN6154A cable, or a separate HKN6154A cable must be ordered. To install, plug the “T” side of the HKN6154A cable to the Siren/PA. Replace the mounting screw on the HKN4363B cable with the double length screw. Plug this side into the “T” cable. Plug the DB-25 end of the HKN6154A into the VRS (see Figure 3).

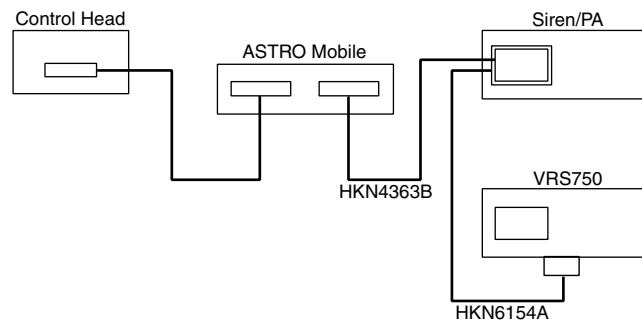

Figure 3. Installing the VRS750 with an External Siren/PA

Installation of the Mounting Trunnion, HLN6855

1. Select the location to mount your VRS750. The VRS750 must be mounted within six feet of the mobile radio. Allow sufficient space around the VRS750 for free air flow for cooling.
2. Using the trunnion mounting bracket as a template, mark the positions of the holes on the mounting surface.
3. Center-punch the spots you have marked and drill a 4 mm (0.16 inch) hole at each.
4. Secure the trunnion mounting bracket with the four screws provided (see Figure 4).
5. Connect the VRS-to-Mobile cable to the 25 pin connector on the bottom of the VRS750.
6. Position the VRS750 in the trunnion.
7. Secure the VRS750 with the two wing screws, and the split and flat washers provided.

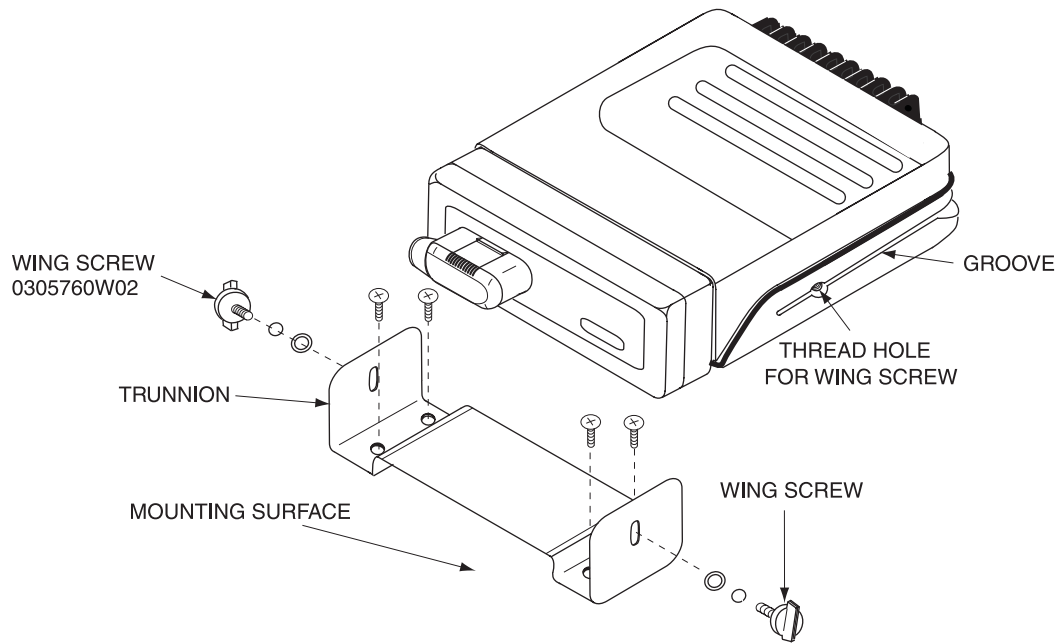

Figure 4. Securing the Trunnion Mounting Bracket

VRS Antenna Installation

Recommended mobile antenna installations are limited to metal body vehicles at the center of the roof and center of the trunk deck locations.

1. Mount the antenna using the instructions provided with the antenna kit by the manufacturer (an antenna is not included with the VRS models). *Mount the antenna as far from the mobile radio antenna as possible, never less than three feet.* An ideal configuration would be a roof-mounted mobile radio antenna and a trunk-mounted VRS antenna.
2. Run the coaxial cable to the VRS750 mounting location. If necessary, cut off the excess cable and install the cable connector.
3. Connect the antenna cable mini-UHF connector to the antenna jack on the rear of the VRS750 (see Figure 5). A mini-UHF crimp connector is provided with each VRS750 unit for easier installation with a pre-existing antenna. Ensure that the antenna's cable connector is fully tightened. An adapter should NOT be used between the antenna cable mini-UHF connector and the VRS750.

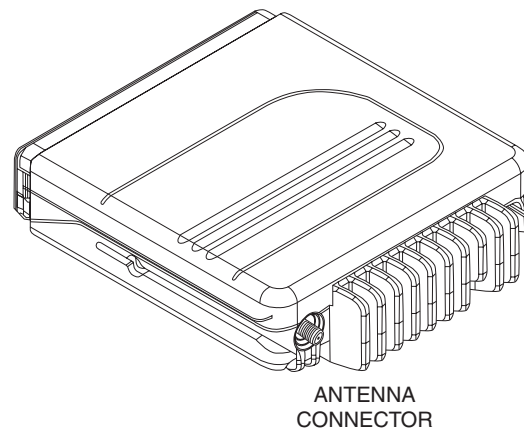

Figure 5. Connecting the Antenna Cable Mini-UHF Connector to the Antenna Jack

VRS750 Programming

The user selectable operating parameters for the VRS750 reside in the ASTRO mobile EEPROM during normal operation. The EEPROM located in the VRS750 holds the tuning parameters. The VRS750 programming windows reside in ASTRO Spectra CPS and are accessible when the "VRS-EP Option" is enabled in CPS under the **Radio Configuration --> Radio Wide --> Advanced Window** (see Figure 6).

The VRS750 does not function without CPS programming and is not pre-programmed at the factory. To ensure operational compatibility from one unit to the next within the fleet, all of the ASTRO Mobile and VRS750/VRS-EP systems should be programmed the same way.

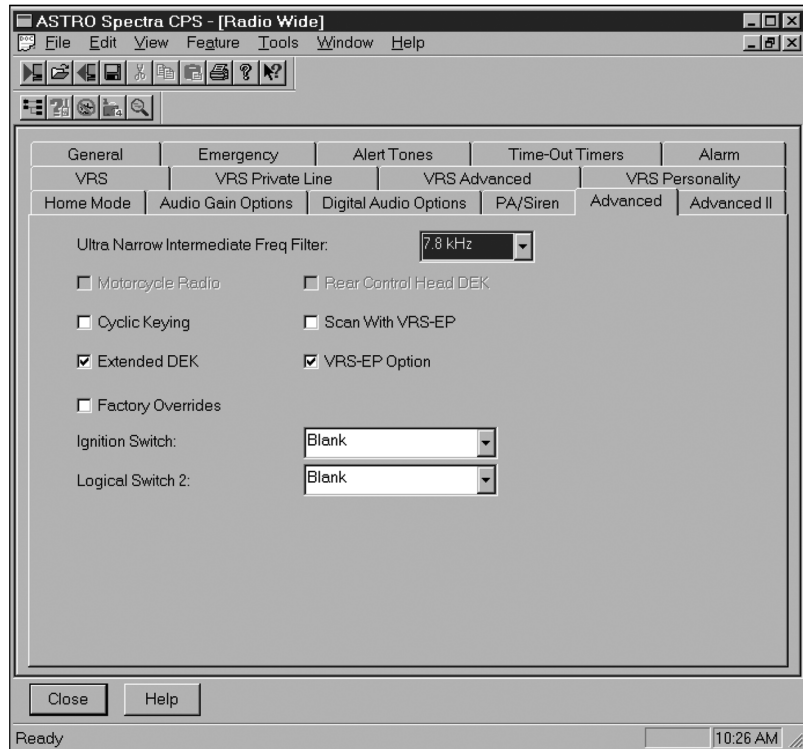

Figure 6. Advanced Window
(Radio Configuration --> Radio Wide --> Advanced)

Special Programming Notes

The **VRS** button can be located in any of the indicator button positions normally used for option buttons.

The VRS750 option can be enabled/disabled by a vehicle interface port (VIP). Use the **VIP Control of VRS** box in the **Radio Configuration --> Radio Wide --> VRS** window (see Figure 8) to enable VIP control and to select whether the input control is active open or active closed. Then use the **Radio Configuration --> Radio Wide --> Radio VIP** window (see Figure 7) to select the VIP to be used. However, the VRS button must still be added to the control unit if it is desired to have the indicator light when the VRS750 is enabled. See the ASTRO Spectra CPS user's manual for details concerning programming the VIP.

NOTE: The ASTRO Spectra CPS user's manual does not indicate that the VRS button is required in order to have the indicator light when the VIP is enabled.

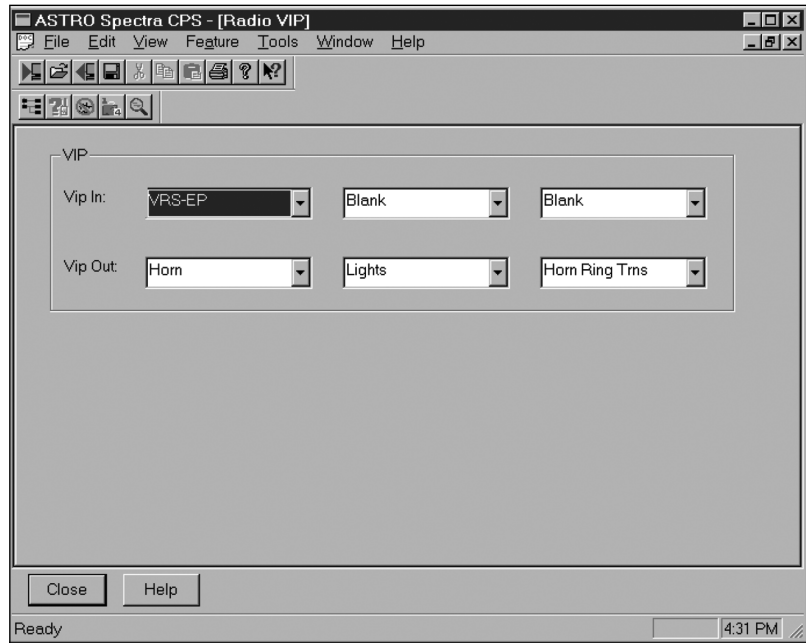

*Figure 7. Radio VIP Window
(Radio Configuration --> Radio Wide --> Radio VIP)*

ASTRO VRS Programming Windows

There are five windows for editing the VRS Option. Four of these windows are in the **Radio Wide** section of **Radio Configuration** while the fifth window is a table for the VRS mode steering PLs. The first window is the VRS subsection of the **Radio Wide** options (see Figure 8). In this window Base Repeater, Mobile Detector, Flashing Display, VIP control of VRS, and Trunking Access Tones can be enabled or disabled by clicking in the box to the left of the option. This window is also where the ICM mode can be selected using a pull down menu. Enabling Base Repeater will add 300 ms of delay to the prioritization routine to account for fixed repeater attack time.

The second window is the **VRS Private Line** subsection (see Figure 9). This window allows the user to select a Mode Steering type, if one is being used. If Mode Steering is set to Disabled, the Access PL Freq. and Access PL Code fields will become user selectable. These fields specify the one PL frequency transmitted by the portable that will be used to access the VRS750. The VRS750 will treat that access PL in the same manner as a "select mode" mode steering PL. To edit these fields click in the Access PL Freq. or Access PL Code box and use the pull down menu to select the desired frequency or code.

Also located on the second window is the VRS Tx Squelch Type. To edit this field click in the box to the right and use the pull down menu to choose between TPL and CSQ. If TPL is selected, meaning that the VRS should transmit to the portable with PL, the VRS Tx PL Freq. and VRS Tx PL Code fields will become user selectable. To edit these fields, click in the VRS Tx PL Freq. or VRS Tx PL Code box and use the pull down menu to select the desired frequency or code.

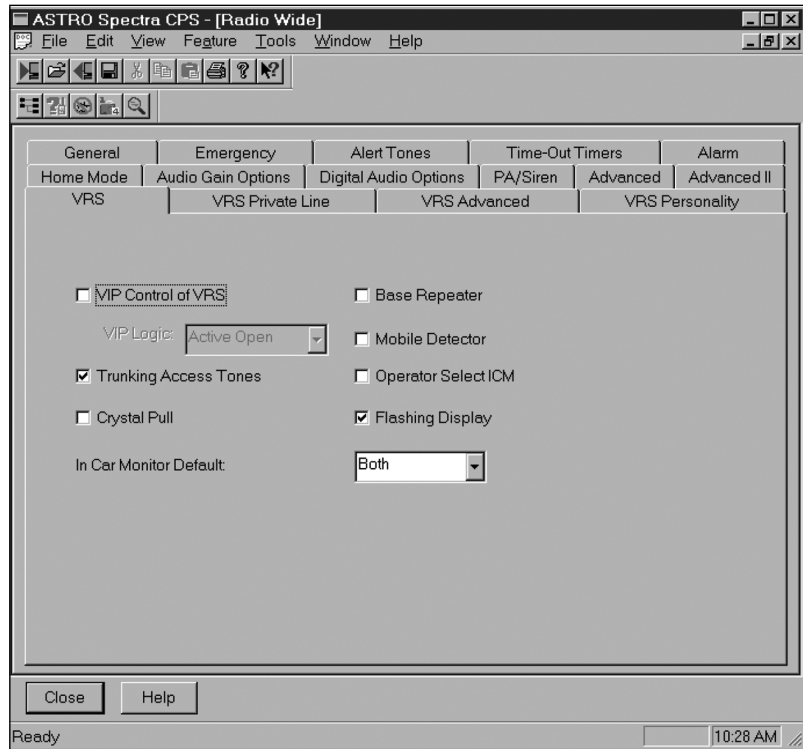

Figure 8. VRS Window
(Radio Configuration --> Radio Wide --> VRS)

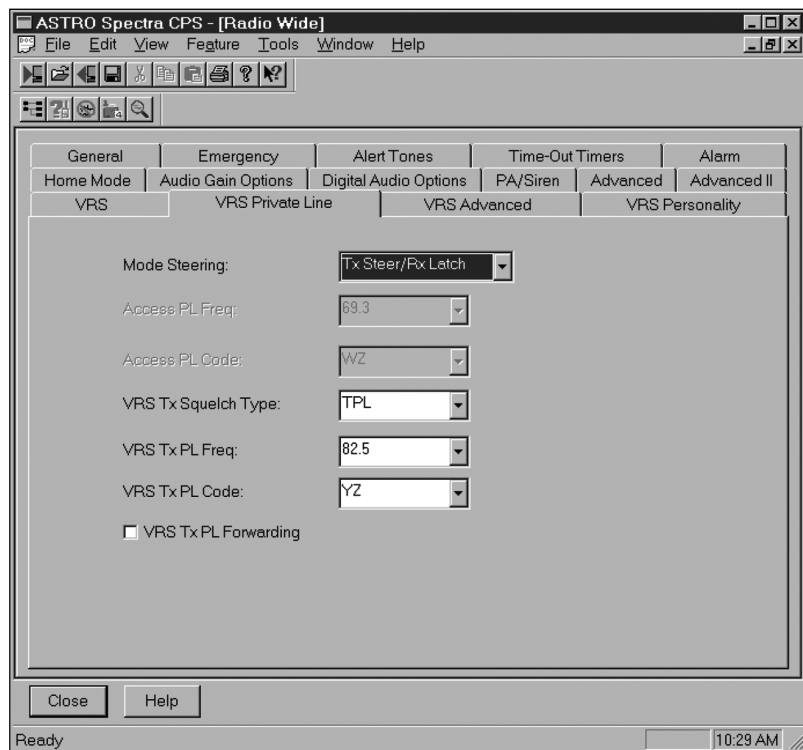
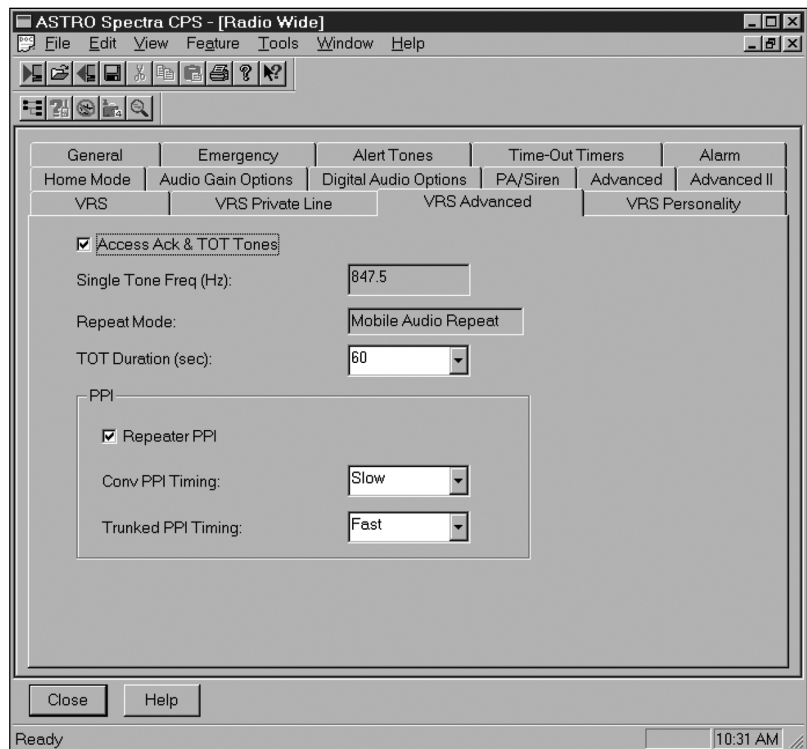

Figure 9. VRS Private Line Window
(Radio Configuration --> Radio Wide --> VRS Private Line)

The third window is the **VRS Advanced** subsection (see Figure 10). This window is used to enable/disable the Access Acknowledgment and Time-Out-Timer Tones and Repeater Portable Priority Interrupt (PPI) as well as selecting the Time-Out-Timer duration. The Time-Out-Timer duration may be set to 30, 60, or 120 seconds, or infinite. The infinite setting should be used with caution, since damage to the transmitter could result from any extremely extended transmission. It should be noted that the Repeater PPI feature must be enabled to allow the multi-unit priority algorithm to function correctly when there will be multiple VRS units on scene. The time between interrupts may be set to **Fast** (500 ms) or **Slow** (2 seconds) for conventional modes and **Fast** (500 ms) or **Slow** (1 second) for trunked modes.

NOTE: When using Rptr PPI, the receiver squelch setting of the portable must be programmed for CSQ (carrier squelch).



*Figure 10. VRS Advanced Window
(Radio Configuration --> Radio Wide --> VRS Advanced)*

The fourth window is the **VRS Personality** subsection (see Figure 11). The **VRS Personality** sets the VRS Frequency Band, Simplex Frequency, Channel Spacing, and TX Output Power for the VRS750. The VRS750 can be programmed for 12.5, 20, or 25 kHz Channel Spacing with a High or Low output power (factory power settings are 2 W for High and 275 mW for Low). Note that the **VRS Personality** will allow the Frequency Band to be set to VHF, UHF R1, or UHF R2 regardless of which model VRS750 is being used, but upon power up the error message “VRS 001” will be displayed if the frequency band is incorrect.

NOTE: Older VRS units, such as the VRS-EP, do not support any of the fields in the **VRS Personality** window. However, these fields can be programmed without having any effect on the VRS-EP, so that the VRS-EP and VRS750 can be interchangeable without reprogramming the mobile.

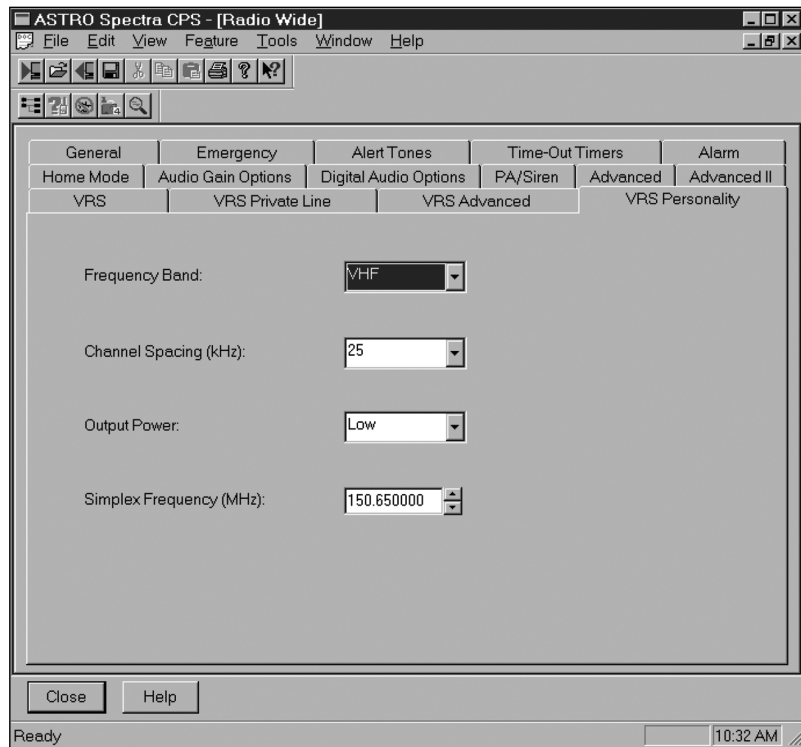

*Figure 11. VRS Personality Window
(Radio Configuration --> Radio Wide --> VRS Personality)*

The **VRS Personality** can be programmed directly into the VRS750 EEPROM using Professional Radio CPS and a new dip switch configuration, Professional CPS Mode. All other operating parameters will still be programmed using the ASTRO Spectra CPS. For more information, refer to “Mode Configuration,” Chapter 6.

The fifth window, **Radio Configuration --> Radio Wide VRS-EP Mode Steering --> VRS-EP Mode Steering List --> VRS-EP Mode Steering - 1** (see Figure 12) is a table containing PL and mode steering information that can be edited. Mode Steering must first be enabled in the **VRS Private Line** window before the mode steering PLs in the table can be edited. To enter the PL codes used in mode steering and their corresponding destinations, enter the desired PL code or frequency by using the pull down menu in each PL Freq. or PL Code box. Then select the corresponding Steering Destination in the same manner.

If the VRS Tx Squelch Type was set to TPL in the **VRS Private Line** window, none of the mode steering PLs may be the same as the VRS Tx PL Frequency.

NOTE: The Receive PL filter internal to the VRS is a low pass filter with a -3 dB point of approximately 170 Hz. As a result, the PLs greater than 170 Hz will be attenuated to allow for a decreased decode sensitivity. The higher the PL frequency the greater the attenuation. The Emergency, Message, and Status features of the VRS are best suited for use with these higher PL frequencies.

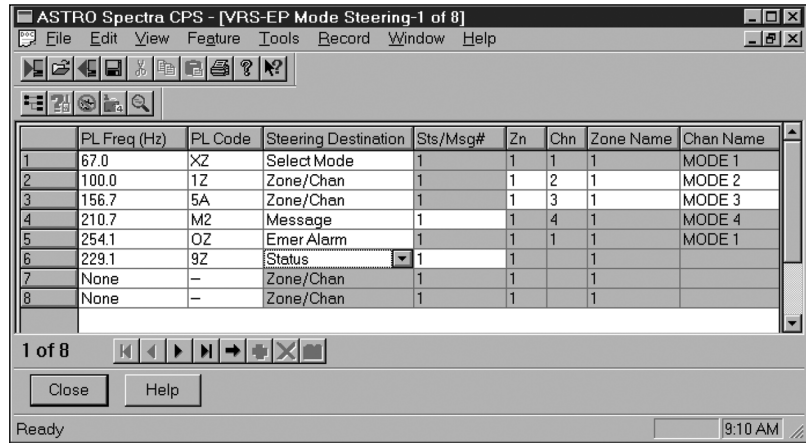

Figure 12. VRS-EP Mode Steering Window

Due to Host memory considerations, the maximum number of Zones allowed to be accessed by the VRS Mode Steering window is 20. Any Zone number greater than 20 will not be allowed in this window but is allowed for normal radio operation.

VRS750 Global Tuner

The Tuner for Professional Radios (Global Tuner) can be used to adjust the VRS750's Transmitter Output Power and Receiver Squelch Settings while in Normal Mode (see Table 6 in Chapter 6). In order to program the VRS750 using the Global Tuner it should be connected to the mobile and to a PC via its COM port as indicated in Figure 13.

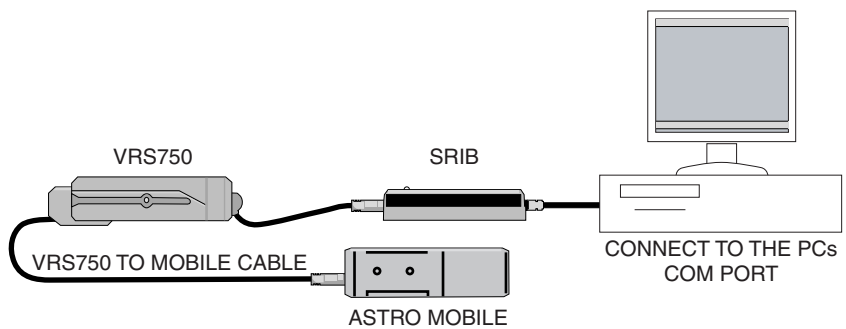

Figure 13. VRS Connection to the PC

Once the setup is complete and the mobile is turned on the current tuning parameters can be read from the VRS750 by selecting **File --> Read Radio Information and Softpots** on the Global Tuner.

NOTE: Radio Serial Number and Radio Model Number shown at the bottom of the screen will not match the model number and serial number of its associating VRS.

Transmit Power Tuning

The VRS750 supports 2 different power levels (High and Low). There are separate alignments for High and Low power (see Tables 2 and 3). We recommend setting and using a **Low** transmit power setting of 275 mW for optimal performance. This output power provides the VRS750 with a similar range as the portable when attached to a mobile antenna. Any deviation from this setting could result in a loss of communication from the portable to the base.

NOTE: Please also note that some countries may have different restrictions on the power level. If you are not sure on the power to tune, please check with your regulatory body. The maximum available power level given in the table below must not be exceeded.

NOTE: When checking the RF power output of the VRS750, always use an attenuator pad of at least 30 dB attached to the radio end of the RF cable. This will avoid an RF mismatch and ensure a stable RF reading that will not change with varying lengths of connecting cable.

NOTE: The VRS750 will be programmed from the factory with a high power setting of ~2 W and a low power setting of ~275 mW.

Table 2. Transmit High Power Level for VRS750s

RF Band (MHz)	High Power (W)
VHF (136-174)	5.2-5.7
UHF Band 1 (403-470)	4.2-4.6
UHF Band 2 (450-527)	4.2-4.5

To perform Transmit High Power Tuning, do the following:

1. Under the **Tx Align** menu, select **Transmit Power**, then select **High** (see Figure 14).
2. Press **PTT Toggle**. This will key the radio up at F1.
3. Adjust the high power level by moving the slider/spin control or keying in values in the edit control (press **ENTER** to confirm selection after typing in the softpot value).
4. Press **PTT Toggle** to dekey the radio, go to the next frequency point by selecting the slider, typing in the edit control box (press **ENTER** to confirm selection after typing in the softpot value) or toggling the softpot value using the spin control.

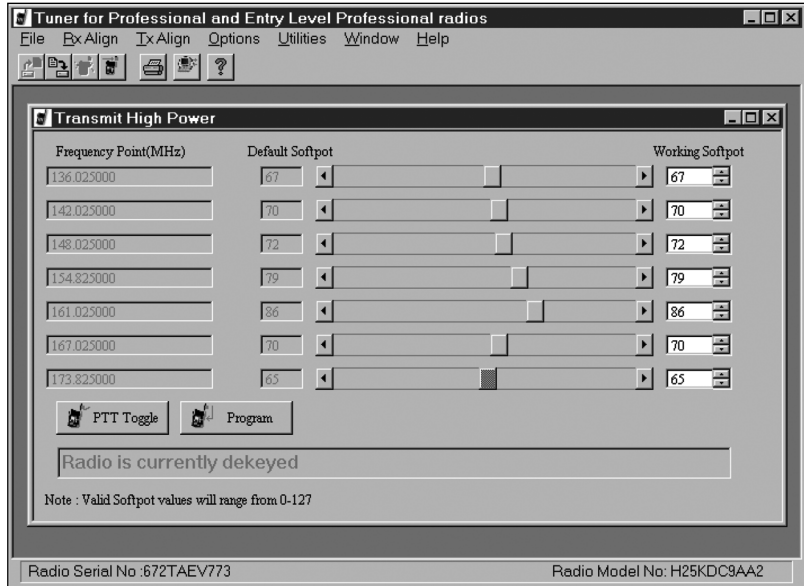

Figure 14. Transmit High Power Window in the Global Tuner

5. Press **PTT Toggle** again to key up the radio at the selected frequency point.
6. Repeat steps 3-5 for (F2-F7).
7. Press **Program** to store the softpot values into the radio's codeplug.
8. Exit the Transmit High Power function. The mobile will reset upon exiting

If low power channels are used, perform Transmit Low Power Tuning as shown in Table 3.

Table 3. Transmit Low Power Level for VRS750s

RF Band (MHz)	Low Power (mW)
VHF (136-174)	240-310
UHF Band 1 (403-470)	240-310
UHF Band 2 (450-527)	240-310

To perform Transmit Low Power Tuning, do the following:

1. Under the **Tx Align** menu, select **Transmit Power**, then select **Low**.
2. Press **PTT Toggle**. This will key the radio up at F1.
3. Adjust the power level by moving the slider/spin control or keying in values in the edit control (press **ENTER** to confirm selection after typing in the softpot value).

4. Press **PTT Toggle** to dekey the radio, go to the next frequency point by selecting the slider, typing in the edit control box (press **ENTER** to confirm selection) or toggling the softpot value using the spin control.
5. Press **PTT Toggle** again to key up the radio at the selected frequency point.
6. Repeat steps 3-5 for (F2-F7).
7. Press **Program** to store the softpot values into the radio's codeplug.
8. Exit the Transmit Low Power function. The mobile will reset upon exiting.

Squelch Tuning

Under **Rx Align**, select **Squelch Attn.** Select either **Squelch Attn. 12.5 kHz**, **Squelch Attn. 20 kHz**, or **Squelch Attn. 25 kHz** Channel Spacing variations (see Figure 15).

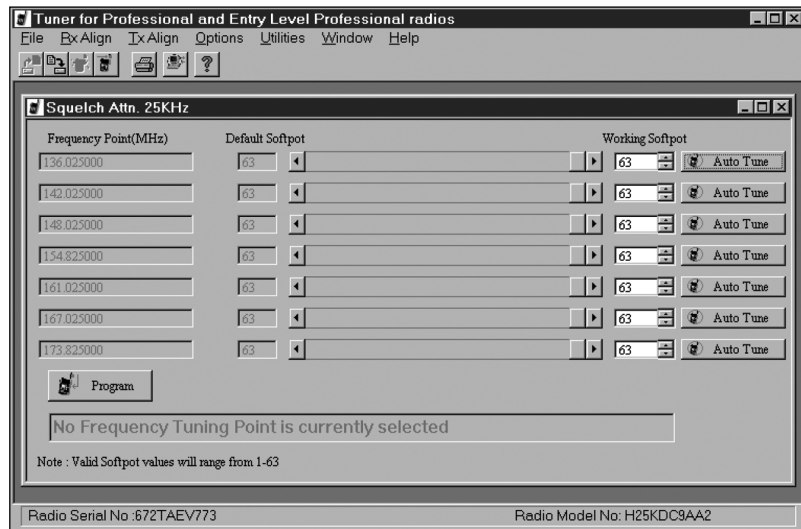

Figure 15. Squelch Attenuation Window in the Global Tuner

1. Apply an RF signal modulated with 1 kHz tone at 60% rated deviation (see Table 10 in Chapter 7) for current frequency point (F1 being the first) of -110 dBm. Make sure that the mobile mic is off HUB and the VRS is programmed for ICM BOTH mode so that the audio will be routed to the mobile speaker.
 NOTE: The -110 dBm squelch level was chosen so that each VRS750 would have the same squelch performance as other VRS750 units as well as VRS-EP units. This prevents one unit from receiving a signal that the other cannot.
2. Set softpot to its maximum value to mute the radio. If the VRS750 remains totally unmute at this setting, leave it at the maximum setting and continue to step 4.
3. Adjust the softpot value by using the slider, keying in the edit box (press **ENTER** to confirm selection), or using the spin controls.

Do this until the radio is totally unmuted. Verify the squelch closing by inputting a signal level of 4 dB lower (than that of the -110 dBm level).

4. Repeat steps 1-3 for F2-F7.
5. Press **Program** to commit the softpot values into the codeplug.
6. Exit the Squelch Attn. function. The mobile will reset upon exiting.

NOTE: The Auto Tuning feature does not work for the VRS750.

Table 4 shows the softpot ranges to achieve approximately -110 dBm. The actual value varies from radio to radio. The VRS transceiver ships from the factory with the softpot set for -110 dBm. In the event that this value needs to be re-set in the field, it is recommended that a communications analyzer or similar piece of test equipment be used to verify these settings.

Table 4. Softpot Ranges

Band	Channel Spacing (kHz)	Approximate Softpot Range for -110 dBm
VHF	25	56-63
VHF	12.5	63
UHF R1	25	44-52
UHF R1	12.5	63
UHF R2	25	43-46
UHF R2	12.5	63

Other adjustments can be made using the Global Tuner in the event that the transceiver is replaced. For more information, refer to "Transceiver Board Tuning Procedure," Chapter 7.

When all adjustments have been made, select **File --> Program All**. This will program all off the softpot values into the VRS750's EEPROM.

VRS750 Upgrade Kit

The VRS750 firmware can be reprogrammed/reflashed using the VRS750 Upgrade Kit. In order to use the VRS750 Upgrade Kit the VRS750 should be connected to a desktop or laptop PC via a COM port as indicated in Figure 13. The Flash adapter (NTN4056A) should be placed between the VRS750 programming cable (3085031D02) and the SRIB (see Figure 16). When connecting the VRS750 to the SRIB via the Flash adapter, **make sure that the switch on the adapter is in the "B" position**. With the ASTRO mobile powered on and "PROG VRS" displayed on the control head, the upgrade can be started. Open the VRS750 Upgrade Kit and click on the "PROGRAM" button. Follow the instructions through to the completion of the Flash process. Upon completion, place the switch on the Flash adapter back in the "B" position and disconnect the VRS750 from the programming cable. For more detailed information on the flashing process, consult the "read me" file for the Upgrade Kit.

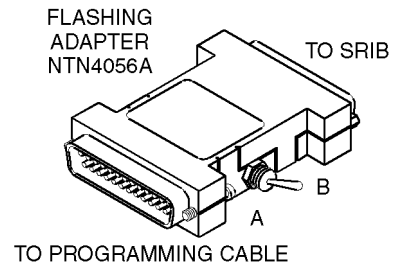

Figure 16. Flashing Adapter

NOTE: The VRS750 Upgrade Kit will request which baud rate to use when flashing the first radio. For the VRS750 the baud rate should not exceed 38,400 bps.

Contact Customer Resources for information on how to obtain this VRS750 Upgrade Kit.

VRS Operation

3

General

The VRS is a crossband repeater that repeats either UHF or VHF portable transmissions through a VHF, UHF, or 800 MHz ASTRO mobile. The repeater cannot be operated with a mobile radio operating in the same band as the VRS unit. In multiple-VRS sites, the VRS uses a priority algorithm to prevent other VRS units from repeating. In this mode, only the highest priority VRS will serve multiple portable users. This prevents interference problems associated with multiple VRS units in proximity to one another.

Control Unit

The VRS may be enabled/disabled from the ASTRO mobile radio's remote-mounted W4, W5, W7, or W9 control head (see Figure 17). The VRS button may occupy any of the indicator button positions. Field programming determines the exact position. The VRS requires an ASTRO radio with a remote-mount control head.

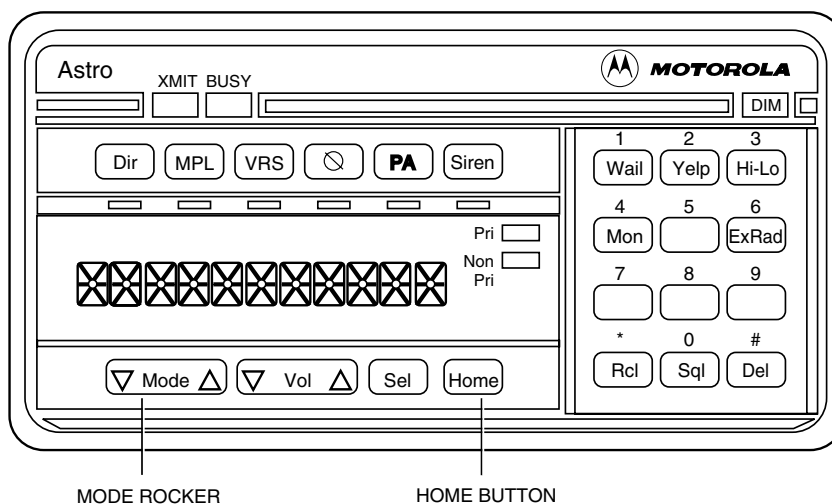

Figure 17. Typical ASTRO Control Head with VRS

When the VRS is turned on, the indicator illuminates and, after transmitting the Single Tone burst, the words "VRS BOTH" (indicating the In-Car Monitor mode) will be displayed momentarily. The indicator remains on for as long as the VRS is on.

When the VRS unit is activated, it transmits Single Tone on the portable frequency, and assumes the priority (active) repeater state. The Single Tone frequency is fixed at 847.5 Hz. For proper operation, all VRS units to be used in the same system must be programmed with

the same Single Tone frequency, as well as other VRS and ASTRO mobile features.

Press the **VRS** button to disable the VRS option. When the system is turned off and then back on from the control head, the VRS option returns to the state it was in immediately before the control head was turned off.

Vehicle Interface Ports

Another method of enabling/disabling the VRS option is through the use of a vehicle interface port (VIP). Using ASTRO CPS, the user can select which VIP to use and whether the input control voltage is to be high/ground or ground/high.

One use of VIP operation connects the VRS switch lead to a portable radio vehicular control charger, such as the AVA, SVA, MVA, MTVA, or ASTRO XTS. Remove the portable from its charger pocket to automatically enable the VRS option. Replace the portable unit in its charger to disable the VRS option. A toggle switch on the portable unit charger allows the portable unit to be removed without enabling the VRS option.

NOTE: This requires the VIP hardware interface kit, 0180757T61, which is not included with the VRS.

Turning the portable unit charger off, then on does not disable the VRS option. The VIP setting controls the on/off state of the VRS option. If the field programmer chooses the VIP option, pressing the VRS button on the control head will only cause the display to change momentarily to the In Car Monitor Mode (“**VRS BOTH**”). It will not enable or disable the VRS as previously described. It is still necessary, however, to select in CPS an indicator button for the VRS if it is desired to have the indicator light when the VRS is enabled.

VRS Access

With the VRS on, press the portable radio’s PTT button to begin transmissions. The VRS programming must include correct PL frequencies to allow the portable unit to access the option. The VRS option receives signals with the correct PL, then uses the mobile radio to re-transmit the signals. The control head’s XMIT indicator lights during the re-transmission.

The VRS re-transmits received mobile signals as explained in the “Mobile Audio Repeat” paragraph on page 21. Note that the XMIT indicator does not light when the VRS is transmitting to the portable.

To transmit directly to the other portable units, turn off the portable transmit PL. This allows you to talk around the VRS without transmitting on the mobile channels.

In-Car Monitor

The “In-Car Monitor” (ICM) feature is for use in a two-man operation where one user (user 1) is out of the vehicle while the other (user 2) remains in the vehicle. This allows user 2 limited access to both mobile and portable communications when the VRS is on, even when the repeater is the priority unit. ICM operation is set to **BOTH**.

ICM Transmissions

VRS BASE:

Press the mobile's PTT to transmit on the frequency corresponding to the mode shown on the control head's display. If this mobile's VRS is the priority unit (in delay state zero), the VRS unit will then become non-priority upon the mobile PTT. If you press the mobile's PTT during portable-to-base VRS activity, a talk-prohibit tone sounds and the mic audio is disabled.

VRS BOTH:

Press the mobile's PTT to transmit simultaneously on the frequency corresponding to the mode shown on the control head's display, and the portable frequency. Use the ASTRO CPS to enable the VRS TX PL generator option to transmit with the proper PL frequency. If you press the mobile's PTT during portable-to-base VRS activity, a momentary talk-prohibit tone sounds and the microphone audio is disabled.

When using VRS BASE or VRS BOTH mode, all mobile transmissions are on the mode that is shown on the control head's display. If the VRS is currently steering to another mode, that steered mode will be displayed on the control head. Any mobile transmissions will be on that new mode until the portable steers the VRS back or the mode rocker switch is used to change modes. If the mode rocker switch is used to change modes, the portable user will not be made aware of this mode change. With Ack Tones are enabled, the portable user will hear a "bad" tone if the mode is changed during the transmission.

VRS Reception

The VRS option has no effect on mobile radio squelch control or normal mobile radio reception. The VRS portable unit's squelch setting is not user adjustable. Portable audio is heard from the mobile speaker of the priority VRS unit as shown in Table 5.

Table 5. Portable Audio Heard from Mobile Speaker

Mobile Microphone	Portable Audio Heard from Mobile Speaker
On HUB	PL*
Off HUB	CSQ

* = any valid repeater access PL

Repeated portable transmissions will always be heard from the mobile speakers.

Portable transmissions without proper PL will only be heard from the mobile speaker if the microphone is off HUB.

Mobile Audio Repeat

The VRS transmits to the portable when audio unmutes the mobile speaker. This allows the user to set the monitor button "on" to defeat the coded squelch requirements of the mobile radio on a base-to-portable transmission or "off" to prevent the VRS from repeating base-to-portable (HUB will also disable this), unless the coded squelch requirements of the mobile radio are met. Button presses (that is, **Volume**, **Mode**, etc.) on the priority mobile unit will also be transmitted by the VRS.

Operation of VRS Options

4

The following sections describe the operation of CPS field-programmable options of the VRS. This includes information about when to use an option and compatibility between options.

Base Repeater

For two-frequency simplex systems using a fixed-site repeater, you can enable the base repeater option. This adds 300 ms of delay to the prioritization routine to account for the fixed repeater attack time. This allows non-priority mobiles to detect any priority mobile in the system through the base repeater.

Mobile Detector

The Mobile Detector feature allows the user to operate VRS units with two-frequency simplex dispatch systems without a base repeater. This feature allows the automatic multi-unit priority resolution algorithm to function in the above scenario. When this feature is activated by the CPS, a non-priority VRS will send a message to the mobile to enable a “Listen Around” feature when a proper portable PL is received.

“Listen Around” switches the mobile radio’s receive frequency to match that of its transmit frequency of the steered mode. The non-priority VRS will count down in priority if its corresponding mobile does not detect the repeated transmission on the “Listen Around” frequency. When the portable is dekeyed, the non-priority VRS will send a second message to the mobile to disable “Listen Around” and return to normal operation. This feature does not use any additional user modes in the mobile.

NOTE: The Mobile Detector feature only works on conventional modes. Trunked modes will be unaffected.

VRS Transmit PL Generator

The transmit PL generator, when enabled, causes the VRS to transmit (base-to-portable), with specific field programmable PL tones. The selected VRS transmit PL frequency cannot be the same as any of the VRS receive PL frequencies that the portable uses to access the vehicular repeater.

VRS Mode Steering

The VRS steering option gives the portable operator the ability to select the current mobile radio mode via PL tones. The total number of Mode-Steered modes can not exceed eight (including emergency, message, and status). The operator may program as many as eight such tones, along with corresponding mobile mode numbers, into the VRS.

The portable operator sets the channel or mode select switch to the position corresponding to the desired mobile mode and keys up the portable. The VRS unit decodes the PL tone and steers the mobile radio to the desired mode. There are two types of steering supported: Transmitter Steering/Receiver Latching, and Transmitter Steering/Receiver Steering.

NOTE: If mode steering is not selected during CPS programming, the programmer will need to enter the repeater access PL, which corresponds to a single access PL with select mode steering.

Steering Types

- <Transmitter Steering/Receiver Latching>—On portable-to-base repeating, the mobile radio is steered to the proper mode as determined by the received PL from the portable. When the portable dekeys, the condition to repeat ceases, and the mobile radio remains on this mode. Thus, all future base-to-portable repeating is heard via the mobile mode last steered by the portable.

The mobile control head will display the steered/latched mode. If, sometime after this operation and while no repeat is occurring, the ICM user keys the mobile with the microphone's PTT button, the mobile will now transmit on the latched mode that is displayed on the control head. If, however, the in-car-monitor (ICM) user changes the selected mode using the mobile's mode rocker switch before pressing the mic PTT, the mobile will now transmit on the new selected mode.

NOTE: For the above type of steering, the portable user will be able to steer back to the selected user mode on the control head by programming one PL destination for Sel-Mode. However, the selected mode can be changed by the rocker mode switch.

- <Transmitter Steering/Receiver Steering>—On portable-to-base repeating, the mobile radio is steered to the proper mode as determined by the received PL from the portable. When the portable dekeys, the condition to repeat ceases, and the mobile radio remains on this mode for 6 seconds. During this 6 seconds, the VRS waits for a repeatable base-to-portable transmission to be received.
 - If a base-to-portable transmission is not received, the mobile will return to the last mode selected by the control head's rocker switch (current user-selected mode).
 - If a base-to-portable transmission is received during the 6-second timer, the timer will be reset back to 6 seconds and start over at the end of the transmission.
 - If the portable is keyed during the 6 seconds, the VRS will handle the destination PL accordingly and reset the timer. If the 6-second timer has not expired, no repeat is occurring, and the ICM user keys the mobile with a microphone PTT, the mobile will transmit on the steered mode and the 6-second timer will start over at the end of the transmission.

Steering Destination Types

There are five types of actions, or “steering destination types,” that the VRS can be programmed to perform as a result of receiving a portable transmission with the specified PL:

NOTE: Each receive PL can only be used once and can only be programmed with one type of steering destination (for example, a single PL cannot be programmed to both change the mobile mode and send a message.)

Zone/Chan

The VRS will command the ASTRO mobile to change to the mode programmed by the CPS. Once the mobile has steered, it will follow the conventions of the type of steering selected (for example, Transmitter Steering/Receiver Latching).

Select Mode

The VRS will command the ASTRO mobile to return to the last mode selected by the rocker switch on the control head. If the portable user has steered to another mode, and the selected mode is changed in the car, the steering will be canceled until the VRS receives another mode steering PL.

Emergency Alarm

The VRS will initiate an Emergency Alarm through the ASTRO mobile, if the mobile is programmed for this type of Emergency, in the same manner as if the Emergency button on the control head were pressed. The type of Emergency (trunked or conventional) depends on the currently selected mobile mode, (trunked or conventional, respectively).

The VRS will only generate an Emergency, not perform a portable-to-base audio repeat, while the portable is transmitting on an “Emergency request” channel. This feature is typically implemented in the portable, using a one-touch button that has been programmed for Emergency-revert to a channel with the proper PL.

Although the portable generates MDC tones, the VRS cannot decode MDC. Instead it responds to the PL of the portable mode on which the Emergency MDC tones are transmitted. All of this is transparent to the user.

Message

The VRS will command the ASTRO mobile to send out a CPS-programmed message on the mode currently displayed on the control head, in the same manner as if the request to send a message had been generated using the control head. The VRS will send out only one message per received portable signal. No mode steering will occur; the currently steered/latched mode and the selected mobile mode will remain as they were before the request to send a message was received.

If the message selected is valid, the VRS will transmit to the portable the mobile tones indicating whether or not the valid message was acknowledged. If the message selected is invalid, (either incorrectly programmed in CPS or not a valid message for the currently displayed mode), the VRS will send a low-pitched alarm tone to the portable.

To generate a message request, the portable user would:

- select the channel on the portable programmed for the message request,

- momentarily press the PTT button,
- wait for the confirmation tone, and
- return the channel selector to a voice channel.

The VRS will not perform a portable-to-base audio repeat while the portable is transmitting on a “message request” channel.

NOTE: A message cannot be generated from the control head while the VRS is activated.

Status

The VRS will command the ASTRO mobile to send out a CPS-programmed status on the mode currently displayed on the control head, in the same manner as if the request to send status had been generated using the control head. The VRS will send out only one status per received portable signal. No mode steering will occur; the currently steered/latched mode and the selected mobile mode will remain as they were before the request to send a status was received.

If the status selected is valid, the VRS will transmit to the portable the mobile tones indicating whether or not the valid status was acknowledged. If the status selected is invalid, (either incorrectly programmed in CPS or not a valid status for the currently displayed mode), the VRS will send a low-pitched alarm tone to the portable.

To generate a status request, the portable user would:

- select the channel on the portable programmed for the status request,
- momentarily press the PTT button,
- wait for the confirmation tone, and
- return the channel selector to a voice channel.

The VRS will not perform a portable-to-base audio repeat while the portable is transmitting on a “status request” channel.

NOTE: A status cannot be generated from the control head while the VRS is activated.

Time-Out Timer

The Time-out Timer (TOT) duration value sets the maximum allowable time for a base-to-portable transmission. The VRS TOT may be set to 30, 60, 120 seconds, or disabled. When a unit times out, it counts up to delay state one. This removes it as the priority unit.

VRS Single Tone

When the VRS unit is enabled, it transmits an audible tone (Single Tone) for 700 mS which is used by other VRS units for the automatic prioritization routine. The Single Tone frequency is fixed at 847.5 Hz.

VRS Mobile-TX Acknowledgment Tones (Conventional Only)

When this option is enabled, the VRS transmits a 750 Hz feedback tone after it has received a repeatable message on the portable frequency. This signals the portable operator that the transmission was received. If the repeated message was cut short due to the mobile TOT being exceeded or the mobile channel being changed during the repeat, a lower-pitched tone (304 Hz) sounds. If the portable user does not hear a tone after completing a transmission, the portable is either out of range of the repeater or there is no priority repeater in the area.

See “VRS Mobile Trunking Tones (Trunking Only)” on page 38 for a description of trunking acknowledgment tones.

Flashing Display

The Flashing Display feature causes the display on the control head to alternate between the current mode and “**VRS BOTH.**” This feature is used primarily when the VRS enable/disable button does not have an indicator light or when VIP activation is used. This feature is normally disabled in CPS. The length of time “**VRS BOTH**” is displayed every 6 seconds is determined by the “temporary message display timer” value. This value (from 250 to 6250 ms [default = 1000 ms]) can be programmed by the CPS. To configure, select **Radio Configuration --> Display & Menu --> Advanced screen.**

Repeater PPI

The Repeater Portable Priority Interrupt (PPI), when enabled, causes a base-to-portable transmission to be interrupted every 1 second in trunked mode or 2 seconds in conventional mode so that the repeater can search for a portable radio signal. (These times are programmable and may be changed to 500 ms for trunked or 500 ms for conventional modes). This interruption may be heard on the portable as a “clicking” noise, but PPI is necessary to give the portable user priority over base-to-portable transmissions, for the self-clearing function of the automatic priority resolution feature, and to allow portable users in trunked mode to break in during system hang time to prevent loss of voice channel. This feature may be disabled through CPS.

Quick-Key

This feature allows the portable user to determine the status of the mobile trunking system. The feature is initiated by a short press of the portable’s PTT that is long enough for the VRS to key the mobile and access the trunking system, for less than 1 second in duration.

Detailed VRS Operation

5

Multi-VRS Operation

The VRS is designed to accommodate multiple VRS units in the same area. This is accomplished by each VRS maintaining a priority level or delay state. During either portable-to-base or base-to-portable transmissions, only the highest priority VRS will transmit or cause a mobile PTT. The procedures for determining priority levels in multi-VRS operation are discussed next.

Determining Priority Levels

Whenever a VRS is enabled, it transmits a Single Tone burst (except if portable activity is already present). The Single Tone burst frequency is fixed at 847.5 Hz. By default, when a VRS (VRS number 1) unit is enabled, it becomes the priority unit with a delay state of zero. When a second VRS unit (VRS number 2) is enabled in the area, it will transmit a Single Tone burst as described. Upon receiving this signal, VRS number 1 will know that another VRS is active and change its priority to delay state one from delay state zero. If a third VRS were to be enabled, VRS number 1 would change to delay state two and VRS number 2 would change to delay state one. This process could continue up until delay state seven is reached by VRS number 1, meaning that eight VRS units have been enabled. After eight VRS units are activated, they begin to stack up at delay state seven.

Portable-to-Base Transmissions

If a portable begins to transmit, only the highest priority VRS will PTT its corresponding mobile for transmission to the base. The other VRS units, however, will be able to hear the portable transmission and monitor for mobile channel activity. Channel activity is verified by a squelch detect of the mobile. For non-priority units, the portable's audio will be sent to the mobile's speaker (unmuted) from the VRS, not from the mobile. This allows the mobile to monitor the correct transmit frequency. If mode steering options are enabled then the non-priority VRS units monitor their mobile's channel activity on the channel steered to by the portable's PL and not on the mobile's current user selected channel.

The non-priority VRS units have a short delay in which they expect to see the squelch detect message. Conventional system units will wait at least 600 ms and trunking system units will wait at least 1500 ms. This time period is referred to as one delay state. If in the appropriate time frame a squelch detect message is not received, the priority VRS unit is assumed to have been disabled and all other VRS units will increase one priority level (for example, go from delay state 2 to delay state 1). The VRS units will continue to count down until a squelch detect message is received. In an extreme case, in which all but the lowest priority VRS units are disabled, it is possible that the remaining VRS unit which was the lowest priority (highest delay state) will have to wait up to 7 delay states before transmitting. This can lead to a transmission delay of up to 10.5 seconds for a trunking unit.

On conventional modes if the VRS <Base Repeater> option is enabled via CPS, then an additional 300 ms time delay is added to the delay states. This allows time for the mobile radios to transmit to and receive from a repeater site.

Base-to-Portable Transmissions

When a base transmits, only the priority VRS unit will transmit to the portable. The other VRS units monitor activity on the portable channel. Similar to the previous case, if portable activity is not detected in the specified time frame after receiving mobile channel activity, the non-priority VRS units will decrease one delay state, until eventually one unit is in priority.

During base-to-portable transmissions, the delay state timing is slightly different from that encountered during portable-to-base transmissions. On conventional modes, the first delay state is 1 second; on trunking modes, the first delay state is 3.4 seconds. All other delay states, on either trunking or conventional modes, are 400 mS. The worst-case delay for a unit to count into priority during a base-to-portable transmission in a trunking system would, therefore, be 5.8 seconds.

See the description of the Portable Priority Interrupt feature on page 34 for information on the self-clearing feature used to re-establish a single priority unit when multiple units are mistakenly in priority. This condition may occur when a VRS unit is activated before arriving on a scene, or in the unlikely case where several units stack up at delay state seven and all higher priority units (those in delay states one through six) leave the scene first or are otherwise disabled.

Single Unit Operation

Normal radio communication between a VRS-equipped vehicle (unit A) and the base is via the mobile radio. When the operator decides to leave the vehicle and use the VRS option, simply press the VRS button or remove the portable from the charger if VIP operation is enabled to turn on the vehicle's repeater. The repeater transmits the Single Tone burst on the associated portable radio frequency and sets the delay state to zero. When the delay state is zero, this unit is the priority unit. See Figure 18.

IMPORTANT NOTE: The VRS is designed to be a stationary repeater system. The VRS unit should always be disabled when the vehicle is moving. FAILURE TO DO SO COULD RESULT IN ERRATIC SYSTEM OPERATION.

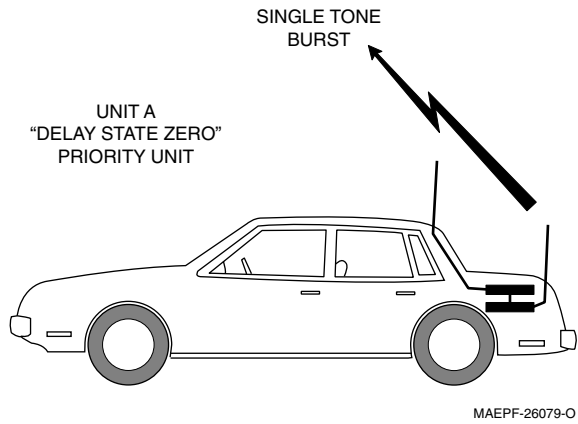

Figure 18. Single VRS Unit Operation

Two-Unit Operation

The arrival of another VRS-equipped vehicle (unit B) into the coverage area of unit A has no effect on unit A's radio operation until unit B's VRS is enabled.

Unless there are portable transmissions occurring when unit B arrives, unit B's repeater transmits a Single Tone burst when its VRS option is turned on. Unit B's repeater priority counter initializes in delay state zero, making unit B the priority unit. Unit A's repeater/portable receives unit B's Single Tone transmission, which sets unit A's repeater to delay state one. See Figure 19. Transmissions from portable units in the area now repeat through unit B. See Figure 20.

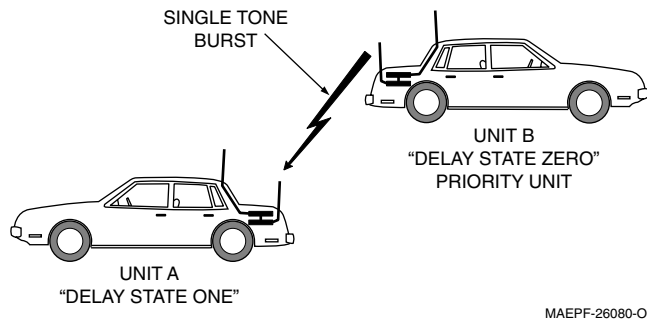

Figure 19. Two-Unit VRS Operation

A portable radio's transmissions (solid arrows in Figure 20) go to all portable radios and VRSs in the area. Because unit B is the priority repeater, it repeats the portable's signal (open arrows in Figure 20) to the base station and other mobile radios.

Unit A cannot countdown and repeat until the delay state one time delay elapses. However, because unit A detects the mobile carrier of the priority unit (open arrow in Figure 20) before the delay expires, the priority counter does not begin the countdown. Unit A remains in delay state one and does not repeat portable transmissions.

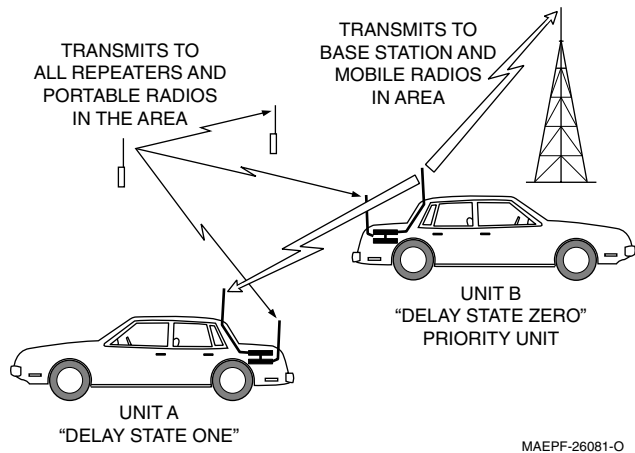

Figure 20. Two-Unit VRS Transmissions

If unit B activates its VRS during portable transmissions, unit B does NOT transmit Single Tone or enable in delay state zero. Unit B must wait until it cannot detect the portable signal before transmitting Singletone and taking over as the priority unit as described above.

Three-Unit Operation

Should another VRS-equipped vehicle (unit C) come into the area, the same sequence of events occurs as previously described in the "Two-Unit Operation" section on page 31. Unit C's arrival has no effect on unit A's or B's radio operation until unit C's VRS is enabled.

Unless there are portable transmissions occurring when unit C arrives, unit C's repeater transmits a Single Tone burst when its VRS option is turned on. Unit C's repeater priority counter initializes in delay state zero, making unit C the priority unit. Unit A's repeater/portable receives unit C's transmission which sets unit A's repeater to delay state two. Unit B's repeater/portable receives unit C's transmission which sets unit B's repeater to delay state one. Transmissions from portable units in the area now repeat through unit C. All lower-priority units will receive incoming portable transmissions, but will not key up their mobiles because they are in a delay state. See Figure 21.

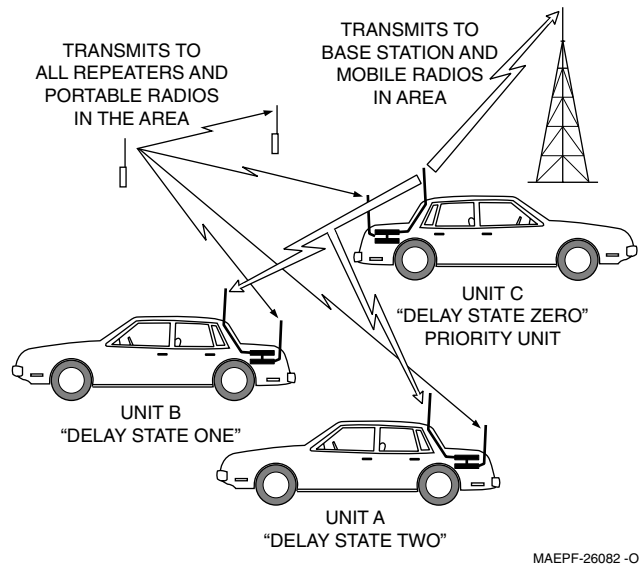

Figure 21. Three VRS Unit Transmission Sequence

Departure of a VRS Unit

The priority unit may change, depending upon the order in which they leave, as vehicles leave the coverage area. For example, in Figure 21, when unit A turns the VRS option off, it has no effect on the priority unit (unit C). Unit C continues to be the priority unit and repeat transmissions.

When the priority unit (unit C) turns the VRS option off and conditions for repeater transmissions occur, the unit in delay state one (unit B in Figure 21) counts down to delay state zero and becomes the priority unit. See Figure 22.

IMPORTANT NOTE: Non-priority units (those in delay state 1 or higher) will not count down into priority if the portable user attempts to send a status or message. If there is no priority unit on scene, the request will be ignored.

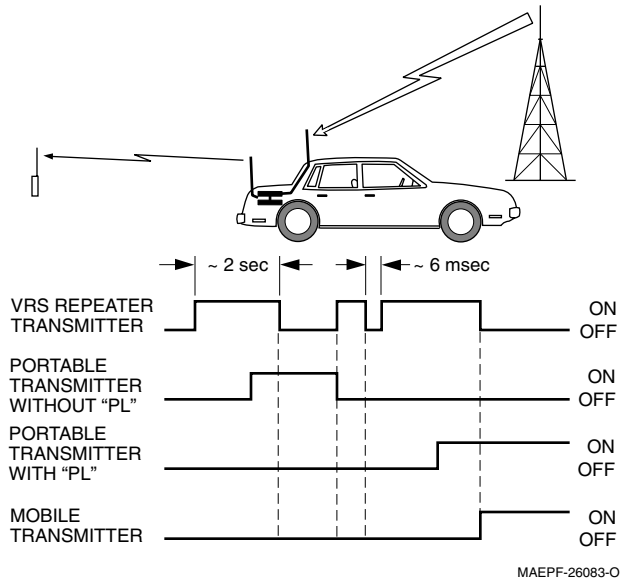

Figure 22. Priority Unit Reassignment

Rptr PPI—Portable Priority Interrupt

NOTE: When using Rptr PPI, the receiver squelch setting of the portable must be programmed for CSQ (carrier squelch).

<Rptr PPI> is CPS programmable. The main function of <Rptr PPI> is to allow the portable to interrupt base-to-portable transmissions. During VRS to portable transmissions, an interrupt is sent to the transmitter every 2 seconds on conventional modes and 1 second on trunking modes. (These times are CPS programmable and may be changed to 500 ms for trunked modes or 500 ms for conventional modes.) There is also a random time factor added to the base interval to prevent two VRS units from interrupting at the same time. This interrupt allows the receiver to monitor portable or other VRS activity for approximately 6 ms. See the timing chart in Figure 23.

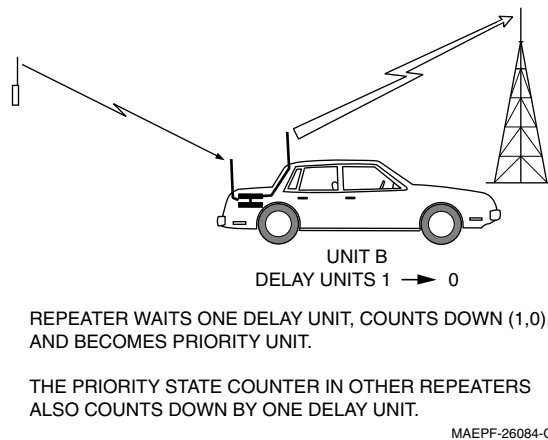

Figure 23. Portable Priority Interrupt

If a portable's signal without PL tone is present when the repeater is interrupted, the repeater transmitter remains inhibited for the duration of the incoming signal. If the portable's signal is modulated with a PL signal, the priority unit repeats the message back to the base station on top of the incoming signal.

In addition to giving the portable user priority over all incoming signals, the Portable Priority Interrupt is used for three basic functions:

1. Self-Clearing—This is used when two or more priority VRS units are on the same scene. On the first base-to-portable transmission, all priority VRS units will start to transmit. The first one to have an interrupt and detect carrier without proper portable PL (meaning another VRS is transmitting) will count up to priority state one, a condition which is referred to as self clearing. This will continue to happen until only one priority VRS is on scene.

As an example, consider a case in which both units A and B are in the priority state (delay state zero). When conditions for repeater transmitting begin (i.e., the mobile receives a base signal), both VRS units begin transmitting. Figure 24 shows the unit B interrupt pulse occurring first (due to the random time factor added to the interrupt interval). When unit B is interrupted, it detects another VRS unit transmitting and so unit B's transmitter remains inhibited. Unit B is set to delay state one and unit A remains the priority unit since by the time unit A's transmitter is interrupted, unit B is no longer transmitting.

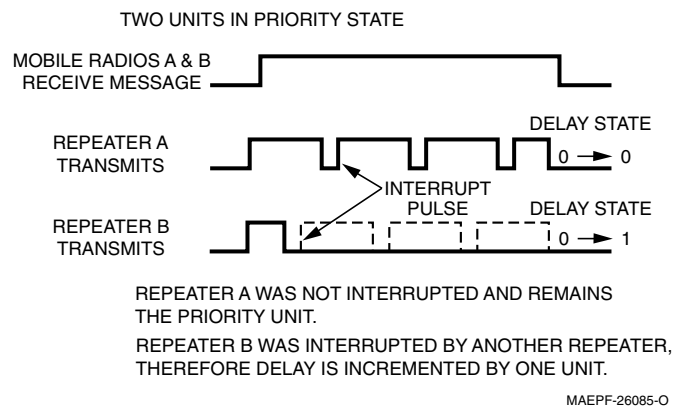

Figure 24. Self-Clearing Timing Diagram

2. Repeater Hangtime—This allows the user to get back into a conventional repeater or trunked system during hangtime. The timing is faster for trunked systems due to the added feature of talk permit tones being passed to the portable. If the portable keys up with proper PL, then the VRS will key up the mobile. If proper PL is not sent, the VRS will assume another VRS is in the area and count itself out of priority.

NOTE: If Repeater PPI is disabled on an analog trunking system with transmission trunking enabled, the Quick Key feature becomes useless, since the user will be unable to break-in during the repeater hangtime after the channel is acquired. For this reason, repeater PPI should always be ENABLED on an analog trunking system.

3. Emergency—This allows the portable to have priority over dispatch.

A drawback of portable priority interrupt is that during all base-to-portable transmissions, the signal drops out for approximately 6-8 ms every: 2 seconds (conventional); or 1 second (trunking) if the “slow” PPI option is chosen; or every 500 ms (either trunking or conventional if the “fast” option is chosen in CPS).

The repeater PPI function may be used by the portable user in the following manner:

During a base-to-portable transmission, the portable user wants to interrupt and transmit to the base.

- Portable must transmit with the VRS correct access or steering PL.
- When the VRS transmitter is interrupted, the VRS will detect channel activity from the portable’s transmission and switch to receive mode.
- The VRS will then transmit VRS TX Audio to the base.
- The VRS RX Audio is routed to the mobile speaker.

TX PL Self-Clearing

As part of the multi-unit resolution prioritization algorithm, TX PL Self-Clearing operates by adding the VRS transmit PL to the list of PLs that the VRS monitors. If a VRS transmit PL is detected by a priority VRS (delay state 0), it will indicate that another VRS is transmitting. This feature will cause the original priority VRS to count up to delay state 1, 2, or 3, and allow the transmitting VRS to remain in priority. The delay state is randomized to prevent multiple units from stacking up in delay state 1. In order to prevent ICM transmissions from other VRS units affecting the priority states, the TX PL Self-Clearing feature only works when detecting TX PL from a VRS that is repeating a Base-To-Portable transmission. This function is not programmable, but has no effect unless TX PL is used. This feature will not operate properly unless all VRS units are programmed to transmit with the same frequency PL, and the receiver squelch of the VRS750 units is set to approximately -110 dBm.

NOTE: The VRS750 ships from the factory with a receiver squelch setting of approximately -110 dBm. If the VRS750 is not going to be programmed with a TX PL, then the Global Tuner can be used to loosen the receiver squelch for better radio performance.

ICM Functions

The in-car-monitor (ICM) allows limited use of the mobile while the VRS is enabled.

<ICM Base> Mode

In this mode pressing the mobile's PTT will cause the mobile to transmit on the mode shown on the control head display. The VRS will not transmit the mic audio to the portable. During portable-to-base repeat operations pressing the mobile's PTT will result in the talk prohibit tone sounding momentarily and the mic audio will not be transmitted to the portable. When the mic is on HUB portable transmissions will not be heard at the mobile's speaker. When the mic is off HUB only portable transmissions with the proper PL will unmute the speaker. The following paragraphs detail how the VRS should operate in <ICM Base> mode during different cases.

1. No VRS repeat operations in progress and the mobile user initiates a PTT.
 - The mobile will key up and transmit mic audio to the base.
 - Mic-Hi line audio is not routed to the VRS transmitter.
2. During a portable-to-base repeat operation, the mobile user initiates a mic PTT.
 - A momentary talk prohibit tone will be heard and the mic audio will be disabled.
3. During a base-to-portable repeat operation, the mobile user initiates a mic PTT.
 - The base-to-portable repeat operation will be interrupted.
 - Mic-Hi line audio is not routed to the VRS transmitter.
 - The mobile will key up and transmit mic audio to the base.
 - When the mobile mic PTT is released, the base-to-portable repeat will continue if the mobile is still receiving a base transmission.

<ICM Both> Mode

In this mode pressing the mobile's PTT will cause the mobile to transmit on the mode shown on the control head display and cause the VRS to transmit to the portable. If the portable is using a PL frequency then the VRS can be programmed to transmit the proper PL. During portable-to-base repeat operations pressing the mobile's PTT will result in the talk prohibit tone sounding momentarily and the mic audio will not be transmitted to the portable. When the mic is off HUB all portable transmissions are heard at the mobile's speaker. When the mic is on HUB only portable transmissions with the proper PL will unmute the speaker. The following paragraphs detail how the VRS should operate in <ICM Both> mode during different cases.

1. No VRS repeat operations in progress and the mobile user initiates a PTT.
 - Mic-Hi line audio is routed to the VRS and transmitted to the portable.

- The mobile will key up and transmit mic audio to the base.
2. During a portable-to-base repeat operation, the mobile user initiates a mic PTT.
 - A momentary talk prohibit tone will be heard and the mic audio will be disabled.
 3. During a base-to-portable repeat operation, the mobile user initiates a mic PTT.
 - The base-to-portable repeat will be interrupted.
 - Mic-Hi line audio is routed to the VRS and transmitted to the portable.
 - The mobile will key up and transmit mic audio to the base.
 - When the mobile mic PTT is released, the base-to-portable repeat will continue if the mobile is still receiving a base transmission.

NOTE: If the VRS is in a non-priority state all portable transmissions will be heard on the mobile's speaker. The above descriptions apply to a VRS unit in a priority state.

Acknowledgment Tones

VRS Mobile-TX Acknowledgment Tones (Conventional Only)

When this option is enabled, the VRS transmits a feedback tone after it has received a repeatable message on the portable frequency. This signals the portable operator that the transmission was received. If the repeated message was cut short due to the mobile TOT being exceeded or the mobile channel being changed during the repeat, a lower-pitched tone sounds. If the portable user does not hear a tone after completing a transmission, the portable is either out of range of the repeater or there is no priority repeater in the area.

VRS Mobile Trunking Tones (Trunking Only)

For trunked modes, the VRS regenerates the standard trunking access tones and transmits them to the portable. These tones, which are essentially the same as those heard at the mobile's speaker, are accessed with the "quick-key" feature. For this operation, the portable user briefly (less than one second) presses the PTT button, and then listens for one of the following tones:

- The "talk permit" tone (three short beeps) indicates to the portable user that the trunking system has granted a voice channel to the mobile and that keying the portable during the trunking system hangtime will result in acquiring this channel.
- The "system busy" tone (a telephone-like busy tone) indicates that, at the time the portable user dekeyed, the trunking system had no voice channel available. If the user does not key the portable again after receiving a system busy signal, a "talk permit" tone will be transmitted to the portable as soon as a voice channel is available.

- The “talk prohibit” tone (a long, low tone) indicates to the portable user that the mobile cannot access the trunking system.

For portable transmissions lasting longer than one second (as opposed to a “quick-key,” which must be less than one second), the VRS will respond with one of the following tones. If the “Trunking Access Tones” option is disabled in the “VRS Options” screen of the ASTRO mobile CPS, the “trunking access good tone” and the “trunking access bad tone” will not be generated.

- The “trunking access good” tone (a single beep) indicates that a portable-to-base transmission has occurred and the mobile remained keyed for the entire transmission.
- The “trunking access bad” tone (a single, low-pitched tone) indicates that all or part of the portable-to-base transmission was not repeated or was interrupted during the portable’s valid PL transmission. This would handle, for example, the case of the mobile’s TOT expiring or the case where a “system busy” is received first, and then a “talk permit,” so that only part of the transmission could be repeated. This tone can also indicate that the VRS has counted down in priority from a delay state of 2 or higher.
- The “talk prohibit” tone (a long, low tone) indicates to the portable user that the mobile cannot access the trunking system.
- The “system busy” tone (a telephone-like busy tone) indicates that, at the time the portable user dekeyed, the trunking system had no voice channel available. If the user does not key the portable again after receiving a system busy signal, a “talk permit” tone will be transmitted to the portable as soon as a voice channel is available.

Message/Status Acknowledgment Tones

There are four different tones that the portable user can receive at the end of a message/status attempt:

- Message/Status Acknowledged Good Tone—This tone is generated by the mobile when the message/status has been acknowledged by the base station. The VRS repeats the tone to the portable.
- Message/Status Not Acknowledged Bad Tone—This tone is generated by the mobile when the message/status has been transmitted but was not acknowledged by the base station. The VRS repeats the tone to the portable.
- Message/Status Not Supported Conventional Bad Tone—This tone is generated by the VRS when it receives a message from the mobile indicating that the message/status number selected is not a valid message or status while the mobile is on a conventional channel.
- Message/Status Not Supported Trunking Bad Tone—This tone is generated by the VRS when it receives a message from the mobile indicating that the message/status number selected is not a valid message or status while the mobile is on a trunking channel.

Non-Priority VRS Rules

A priority VRS is placed into non-priority mode when one of the following occurs:

1. It receives a Single Tone burst at the fixed frequency of 847.5 Hz.
2. During a base-to-portable repeat, it receives a VRS/portable frequency RF signal without proper PL during the PPI.

When a VRS goes from priority to non-priority, the internal delay state changes from 0 to 1. Upon subsequent reception of Single Tone bursts (that is, other VRS units activate in the same coverage area), the non-priority unit will increase delay states up to a maximum of 7. While in non-priority, the following occur:

Portable-to-Base Non-Priority Operation

1. Upon reception of a portable frequency RF signal with proper PL, the VRS will determine if the mobile of another VRS system is repeating the signal.
2. For the prioritization routine to function, all of the mobiles with a VRS must be able to receive other mobile transmissions, either directly (TX=RX), or on a trunked system (TX≠RX), or through a base repeater (TX≠RX) in conventional modes with the <Base Repeater> feature enabled. For conventional non-repeater dispatch systems (TX≠RX), the Mobile Detector must be enabled for the prioritization routine to function properly.
3. The VRS will determine if the mobile of another VRS system is repeating the portable signal by steering the mobile to the mode corresponding to the received PL. If, within one delay state (at least 600 ms for conventional, at least 900 ms for <Base Repeater>, and at least 1.5 seconds for trunking), the mobile in the non-priority VRS system does not receive the repeated signal, it will countdown from the current delay state.
4. Upon reaching delay state 0, the non-priority VRS will become the priority VRS and start repeating. The maximum delay for a non-priority VRS to countdown into priority is 4.2 seconds for conventional, 6.3 seconds for <Base Repeater>, and 10.5 seconds for trunking.
5. If the VRS does detect another VRS system repeating within the delay state, it will stop the countdown process and stay non-priority.

Base-to-Portable Non-Priority Operation

1. Upon reception of a repeatable base signal, the non-priority VRS will monitor for a VRS-to-portable transmission from another VRS system (that is, a signal on the portable frequency without proper VRS access PL).
2. If, within one delay state, the VRS does not receive the repeated signal, it will countdown from the current delay state.

3. Upon reaching delay state 0, the non-priority VRS will become the priority VRS and start repeating. The maximum delay for a non-priority VRS to countdown into priority is 3.4 seconds for conventional and 5.8 seconds for trunking.
4. If the VRS does detect another VRS system repeating within the delay state, it will stop the countdown process and stay non-priority.
5. If the VRS detects a portable frequency signal with proper PL while receiving a repeatable base signal, it will handle it according to the portable-to-base case.

ICM Non-Priority Operation

The ICM feature will continue to operate as described in the “ICM Functions” section except for the following:

1. While receiving a portable transmission with correct repeat qualifiers, the unit will not repeat as long as the unit is non-priority.
2. During a portable-to-base transmission with correct PL, the non-priority VRS will steer the mobile to the mode programmed for that PL frequency. This allows the mobile to monitor for priority repeater traffic.

Emergency

Emergency Feature Summary

An emergency alarm is initiated when the VRS receives a portable transmission which contains the Emergency Alarm PL, as programmed in the mode-steering screen of CPS. Upon decoding the Emergency Alarm PL, the VRS sends an “enter emergency” bus message to the mobile radio. The mobile radio will respond as if the **Emer** button had been pressed on the control head, and will proceed with the Emergency operation which is programmed by the CPS.

In addition, an “emergency acknowledgment” tone is transmitted by the priority VRS as part of the automatic multi-unit priority resolution algorithm. The “Emergency ACK” tone generated by the VRS is a 1250 Hz tone lasting 500 ms in duration. Once in Emergency Alarm, the VRS ignores subsequent portable transmissions with the Emergency Alarm PL until the mobile exits Emergency. (The “Emergency ACK” tone, however, will always be generated in response to each portable transmission with the proper Emergency Alarm PL).

Emergency Call and VRS are mutually exclusive. Even if the mobile is programmed for alarm and call, when the alarm case is exited, the mobile will not transition into Emergency Call while the VRS is activated. Likewise, if the mobile is in Emergency Call, the VRS cannot be activated.

Emergency Feature Operation

Whether the mobile is programmed for silent or non-silent alarm is transparent to the VRS. However, the Emergency Alarm sequence changes slightly between the silent and non-silent case. The main differences are listed below:

1. The alarm exit sequence

For non-silent alarm, any of the following will cause the mobile to exit Emergency:

- Extended keypress of the **Emer** button on the mobile's control head.
- Mobile microphone PTT or a portable-to-base repeat.
- Mobile exhausts its retries without receiving an "Emergency ACK" from the base.
- The mobile receives an "Emergency ACK" from the base.

For silent Alarm, any of the following will cause the mobile to exit Emergency:

- Extended keypress of the **Emer** button on the mobile's control head.
- Mobile mic PTT or a portable-to-base repeat.

2. The mobile will not unmute due to base traffic during silent alarm, and therefore the priority VRS will not attempt a base-to-portable repeat. If there are other, non priority VRS units in the area, they will perform the base-to-portable repeat without counting into priority.

IMPORTANT NOTE: While in Emergency, attempts to send a message or status from the portable will be ignored and WILL NOT cause the mobile to exit Emergency.

Hardware Detailed Theory of Operation

6

The VRS750 contains two main modules: a transceiver and an interface board.

Transceiver

This module is an Analog synthesized FM device that contains the receiver, transmitter, and controller section. A flex cable connects the transceiver's two accessory connectors to a single connector, J30, on the interface board. The RF jack is connected to W101 on the interface board via the 50 ohm coaxial cable.

The VRS750 software is embedded in the digital portion of the transceiver's controller which consists of a microcontroller and associated EEPROM, RAM, and ROM memories.

NOTE: This transceiver cannot be used as a stand-alone portable.

Interface Board

This board provide power regulation, bus translation circuitry, audio routing circuitry, Single Tone Encoder and Decoder circuitry, programming circuitry, and mode configuration.

Power Regulation

The VRS750 is powered by the mobile's Radio_SWB+ (13.8 VDC) at the connector P102-22. L101 and C137 are used to filter alternator whine from this signal before providing it as SWB+ to the interface board. The VRS750 utilizes the mobile's analog (P102-2, 10, 11, 21) and digital grounds (P102-18).

U111 regulates the SWB+ down to +5 VDC. This voltage provides power for several switching transistors and voltage dividers on the VRS750 board. U118 is a micropower low dropout regulator used to provide +9.6 V for all of the analog audio circuitry. R162 and R164 form a divider network from this 9.6 V to produce the 4.8 V (VAG) used to bias the audio circuits. Finally, U129 is a three-terminal regulator used to provide the regulated 7.5V to the transceiver via Q113 in the reset circuit. SW7.5 V is provided to the transceiver at pad P31.

Bus Translation Circuitry

The devices U100-2, U103, Q100, Q101, Q102, Q103, and Q104 are used to separate messages from the bi-directional SB9600 serial bus Bus+, Bus-, and Busy into and from the single direction RXD, TXD, BUSY OUT, and BUSY IN signals at the transceiver.

The transceiver's microcontroller can be reset by an external device by generating an active high reset pulse at pin P102-19, RADIO_RESET. This will cause Q109 to drive J30-5 low.

Audio Routing Circuitry

There are four paths which are used to route audio between the mobile and the transceiver: AUX_RX_AUD, TX_AUDIO, MOB_MIC_HI and FIL_AUD. During the three types of communications of the VRS (Portable-to-Base, Base-to-Portable, and In-Car-Monitor), the routing is as follows:

Portable-to-Base

On channel RF signals are received by the transceiver through the connector, W101. The transceiver provides demodulated audio to the interface board at EXT_SPKR+ (J30-17) and URX_SND (J30-11).

The receive audio at EXT_SPKR+ is volume controlled. The transceiver monitors the mobile's volume setting and then updates its volume accordingly. The audio is filtered by a 2-pole low pass filter, U107-1, which has a corner frequency of 3.2 kHz. T1, a 600-ohm to 600-ohm audio transformer, is used to isolate any ground noise such as alternator whine from the receive audio before being routed to the mobile at AUX_RX_AUD (P102-7). During portable-to-base transmissions the mobile routes this audio to its speaker.

The receive audio at URX_SND is at a fixed level of 260 mVrms. It is attenuated through op amp circuit U104-3 to a level of 60 mVrms which can be adjusted via potentiometer R146. T2, a 600-ohm to 600-ohm audio transformer, is used to isolate this audio from any ground noise such as alternator whine before being routed to the mobile at TX_AUDIO, P102-8. During portable-to-base transmissions, the mobile routes TX_AUDIO to its transmitter.

Base to Portable

The MIC_FIL_SEL (J30-15) and TONES-MOBILE_AUD (J30-8) control signals are generated by the microcontroller and are used to control audio routing circuits, U101-1 and U101-3, for "Base to portable" activities.

FIL_AUD (P102-6)—This audio path contains receive audio from the mobile during Base-to-portable transmissions. The receive audio passes through op amp circuit U104-1 and can be level adjusted via potentiometer R150. When a base-to-portable repeat occurs, TONES_MOBILE_AUD is in a low state and MIC_FIL_SEL is in a high state so that FIL_AUD is routed to the transmitter input (EXT_MIC, J30-19).

In-Car-Monitor

The MIC_FIL_SEL (J30-15) and TONES-MOBILE_AUD (J30-8) control signals are generated by the microcontroller and are used to control audio routing circuits, U101-1 and U101-3, for "In-Car-Monitor" activities.

MOBILE_MIC_HI (P102-12)—This audio path contains microphone audio from the mobile during In-Car-Monitor (ICM) transmissions. The microphone audio passes through op amp circuit U104-4 and can be level adjusted via potentiometer R148. During an ICM transmission, both MIC_FIL_SEL line and TONES-MOBILE_AUD line are set to a Low state to configure both mux U101-3 and mux U101-1 to route the mobile mic audio to the transmitter input (EXT_MIC, J30-19).

Single Tone Encoder

The VRS750 Single Tone Encoder (U100-1, U124-3, U124-2, and U124-4) is used to produce a tone which is transmitted by the transceiver when the VRS750 is activated. Other VRS750 repeaters that are on in the operating area receive this Single Tone transmission. The other repeaters will then increment their priority counters by one while the transmitting VRS750 goes to delay state zero and becomes the priority repeater.

When the VRS750 is in transmit mode for Single Tone, the microcontroller generates a square wave at a set frequency of 847.5Hz to the SNGL_TX_DATA (J30-6) pin. The control signal, TONES-MOBILE_AUD, is set to a High state to allow the Single Tone signal to be routed to the input of the Single Tone Filter. The Single Tone Filter is a band pass filter that allows frequencies between 300Hz and 1.7 kHz. U124-4, R126 and R127 are for gain adjustment. The resulting sine wave is then sent to the transceiver to be transmitted on EXT_MIC (J30-19).

This circuit is also used when the transceiver generates various VRS750 acknowledgment tones.

Single Tone Decoder

The VRS750 Single Tone Decoder (U100-1, U124-3, U124-2, and U124-1) detects other Single Tone transmissions, then increments the priority counter.

VRS_TX*_RX from the microprocessor is set to a High state when the VRS750 is in the Single Tone Decode mode (receive mode). When this signal is high, U101-2 allows receive audio (URX_SND, J30-11) to pass to buffer U100-1. The output of the buffer drives the low-pass filter that is also used in the encoder circuit. U124-1 and the associated diodes, D100 and D101, produce a square wave which is divided down to 3.3V by R172 and R173. This signal, SNGL_DET(J30-12), is then sampled by the microprocessor to determine if Single Tone is present.

Boot Control Circuitry

The firmware for the VRS750 is stored in the transceiver's Flash memory. This firmware can be programmed using the VRS750 Upgrade Tool (refer to "VRS750 Upgrade Kit," Chapter 2). Prior to programming the firmware, the microprocessor must be placed into bootstrap mode.

To place the microprocessor into bootstrap mode, it must be reset while the BOOT-CNTRL (J30-28) pin is grounded. This pin is grounded when the programming cable is connected and the flash adapter switch is turned to the "A" position.

When the BOOT-CNTRL line is grounded, Q100 which controls U102 and U105, is opened and 9.6V passes through U102-2 to the base of Q112. Q113 opens and disconnects SW7.5 V from 7.5 V. At this point there is no supply voltage to the transceiver.

Meanwhile, 9.6V is also applied to the base of Q112 thus charging up capacitor C182. After approximately 1.5 seconds, C182 is charged to a voltage that saturates Q111, causing Q112 to open and Q113 to turn

On. SW7.5V is connected back to 7.5 V again. At this point the microprocessor on the transceiver has been reset and is now in bootstrap mode.

To prevent mobile bus messages from corrupting the flash programming of the transceiver, the control signals to U102-3, U105-2 and U105-3 are applied with 9.6V to disconnect the Bus+ (P102-5), Bus- (P102-14) and Busy (P102-23) lines from the mobile when the BOOT-CNTRL line is grounded.

Program Sense

The PROG_SENSE signal (J30-10) is monitored by the VRS to detect when the programming cable is connected at connector P101. This line will be pulled to ground when the programming cable is connected or will be 3.3VDC when the programming cable is not connected.

The programming cable is used when adjusting the VRS using the Tuning Tool (refer to “VRS750 Global Tuner,” Chapter 2) or when updating the VRS firmware using the VRS750 Upgrade Kit (refer to “VRS750 Upgrade Kit,” Chapter 2).

To prevent mobile bus messages from corrupting the codeplug programming and/or tuning of the transceiver, the control signal to U105-1 pin 10 is driven to ground.

Mode Configuration

There are various operating modes of the VRS750. The mode is selected at power-up based on the settings of dipswitch S1 pins 1, 2 and 3. Pin 4 is unused. Table 6 shows the supported modes:

Table 6. VRS750 Supported Modes

Operating Mode	S1 Pin 1	S1 Pin 2	S1 Pin 3
Normal	On	On	On
Test Mode	Off	Off	Off
ATE Test Mode	On	Off	Off
Professional CPS Mode	Off	On	On

Normal mode is the default and standard configuration for the VRS750. The Test Mode configuration is used when the transceiver requires tuning. The VRS750 can be put into Test Mode by placing S1 Pins 1, 2, and 3 to the OFF position before system power-up. When this setting is detected by the VRS μ P at power up, the following will occur:

- VRS TEST is displayed momentarily on the control head.
- Portable Priority Interrupt is disabled.
- VRS TOT disabled.
- TX PL disabled.

To exit Test Mode, power down the VRS750 and reconfigure S1 for Normal mode.

The ATE Test Mode configuration is used by Motorola for testing purposes. Professional CPS Mode is available for when the user requires the transmit and receive frequencies to differ. Operation during this mode is not advised and if required please contact your Motorola sales representative for details about this mode. All other combinations of the dipswitch are not supported and will default to the Normal mode.

Maintenance and Troubleshooting

7

The following paragraphs contain information to help you maintain and troubleshoot the VRS. A list of recommended test equipment is found in the “Recommended Test Equipment, Service Aids, and Tools” section of the ASTRO Spectra Basic Service Manual, Motorola publication 68P81076C20.

Additional information may be found in the Troubleshooting Chart in this manual.

Troubleshooting Procedures

VRS Activation

1. Turn on the mobile radio control head. The radio should go through self-check and then display the home mode of the mobile radio.
2. Possible error messages on power up are:
 - ERR 12/10—No VRS detected. See “Common Power-Up Problems” section on page 50 for possible solutions.
 - ERR 12/81—Flash EPROM failure. If re-flashing the unit does not fix this problem the transceiver should be replaced.
 - ERR 12/82—Codeplug checksum error. After verifying that both mobile and VRS have the correct software version, checking the mobile-to-VRS connection, and moving the cable away from any interference, reprogram the VRS750’s codeplug using the correct version of the CPS. If the codeplug cannot be corrected using CPS then the unit will need to have a new default codeplug written to the unit. Contact Customer Service for the default codeplug that corresponds to your model (see Table 7).

Table 7. Default Codeplugs

Band	VRS750 Model No.	VRS750 Back Cover Kit No.	Internal Codeplug No.
VHF	P2080	PMLD4196	PMUD1479
UHF R1	P2081	PMLE4242	PMUE1433
UHF R2	P2082	PMLE4243	PMUE1476

- ERR 12/84—CONFIG register corruption. The unit should be flashed with the correct version software. If this fails to correct the problem, the transceiver should be replaced.
 - ERR 12/88—HC11 RAM failure. Replace the Transceiver.
 - VRS 001—VRS Synthesizer out of lock error. See “Common Power-Up Problems” section on page 50 for possible solutions. If the solutions in the “Common Power-Up Problems” section do not fix the error then the transceiver should be replaced.
 - PROG VRS—The VRS750 is in programming configuration. This is only an error if the programming cable is not plugged into the front connector of the VRS750. Reset the ASTRO Mobile radio and if the problem is not corrected check P101 Pin 9 and the PROG_SENSE line for any shorts to ground.
3. Enable the VRS unit by pressing the VRS button on the mobile control head.
- “VRS BOTH” must be displayed momentarily on the control head and the indicator must light.
 - Verify a short single tone burst is transmitted upon activation at approximately 3 KHz deviation for a channel spacing of 25 kHz.

NOTE: Because of the short burst, it may be necessary to verify the deviation on the modulation scope instead of the usual deviation meter. Activation may be repeated by pressing the VRS button once to disable the unit and again to reactivate it.

Common Power-Up Problems

1. “ERR 12/10” message is displayed on power-up.
- The VRS mobile interface cable is disconnected or bad.
 - Verify the VRS Firmware is correct. Immediately after power up press the HOME button on the control head five (5) times and verify the correct firmware version is displayed.
 - Check all regulators for proper voltages. The 9.6-volt regulator is accessible at TP116.

CAUTION: Do not probe U118 pin1 when the unit is powered. U118 will shut down without any recovery if pins 1 and 2 are accidentally shorted to each other.

2. “VRS BOTH” message does not display momentarily on control head when VRS is enabled.
- VRS is receiving a VRS frequency signal. (VRS will not display “VRS BOTH” or transmit Single Tone if there is RF activity on the VRS frequency.)
 - Check the VRS750’s squelch setting.
3. “VRS 001” message is displayed on power-up.
- VRS Frequency Band in the VRS Personality of the ASTRO Mobile codeplug is incorrect.

- Check the VRS750's codeplug for incorrect programming.
- Re-flash the VRS750 with new firmware using the VRS750 Upgrade Kit.

Common Operational Problems

1. Common Portable-to-Base Repeat Problems.
 - Check portable for correct transmit frequency and PL.
 - Check portable for low battery.
 - Check VRS internal RF cable for loose connection.
2. Common Base-to-Portable Repeat Problems
 - Check portable for correct receive frequency and PL.
 - Check mobile for correct frequency.
 - Check that portable is set for the bandwidth corresponding to the VRS.
 - Check VRS internal RF cable for loose connection.

Disassembly & Reassembly Procedures

The disassembly/reassembly procedure covers all VRS750 models.

CAUTION: Refer to the "Safe Handling of CMOS Integrated-Circuit Devices" section at the beginning of this manual prior to disassembling the radio.

Disassembly to Interface Board Level

Remove Front Housing

1. Disconnect the Programming Connector Cover by squeezing the top and bottom of the connector together, disengaging the bottom snap then the top and pulling straight out.
2. Remove the gasket within the recessed area for the 18-pin programming connector.
3. Insert a small flat-blade screwdriver or like instrument in the side groove at the interface between the remote front housing and the main chassis (see Figure 25). Press while pulling the housing away from the chassis until the snap releases. Repeat the operation on the opposite side.
4. Pull front housing off the chassis.
5. Remove white retainer (p/n 4205395X01) from the header (or front housing).
6. Remove the 18 pin connector (2805347X01) from the front of the chassis.
7. Remove the front cover gasket.

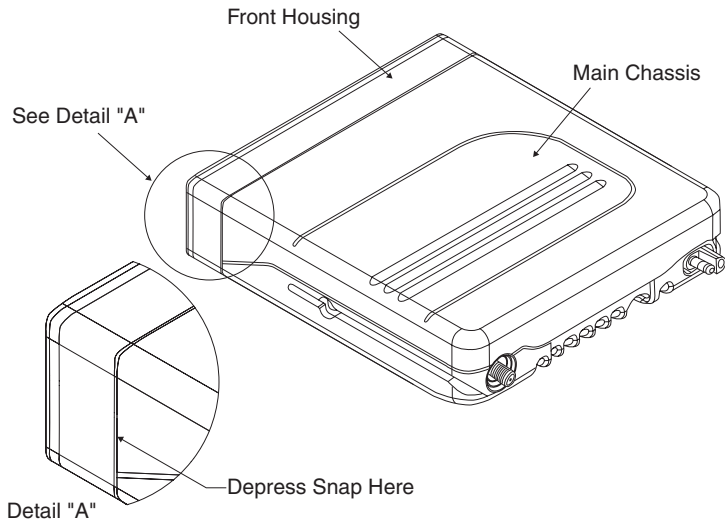

Figure 25. Removing the Front Housing

Remove the Top Cover

1. Insert a wide flat-blade screwdriver or like instrument in the recess area on the side of the main chassis near the RF connector end (see Figure 26).
2. Pry the cover off the chassis by pushing the handle of the screwdriver in and toward the chassis. This will disengage the snap between the cover and chassis.
3. Repeat Step 1 and Step 2 for the opposite side of the radio.

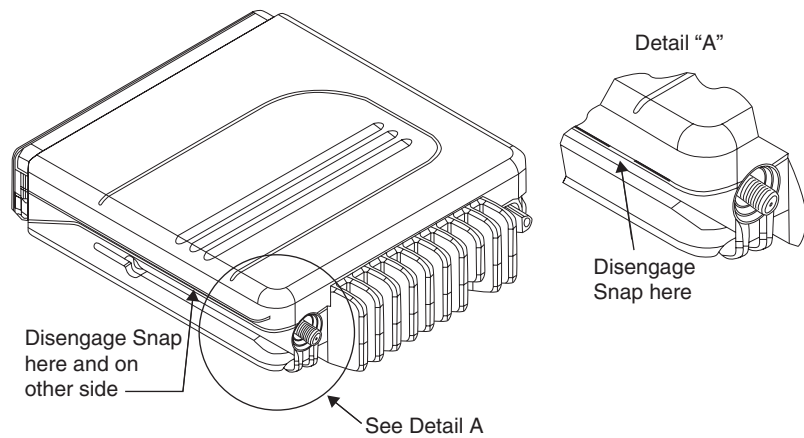

Figure 26. Removing the Top Cover

Remove the Interface Board

1. Remove the antenna connector retaining clip by inserting a small flat-blade screwdriver or like instrument between the clip and the top of the cavity wall as shown in Figure 27. Gently pry upwards.
2. Remove the board screws with a T-10 Torx Driver.
3. Carefully remove the interface board by rotating it out of the chassis. Slowly lift the board on the front edge while pushing up on the board through the accessory connector opening. Pull the board forward out of the chassis (see Figure 28).

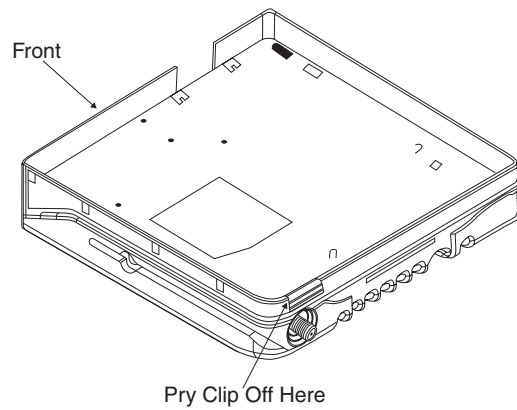

Figure 27. Removing the Antenna Connector Retaining Clip

4. Retain the heat conductive insulator from under the regulator.

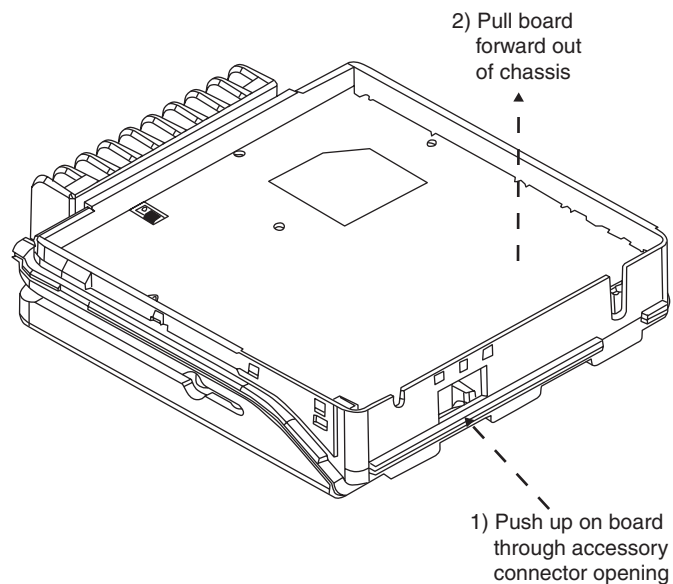

Figure 28. Removing the Interface Board

Transceiver Disassembly

1. Detach the RF cable assembly from the right-angle SMB connector on the interface board.
2. Turn over the interface board. Remove the flex connector retainer, 4285168D01.
3. Gently lift the clasps of the 20-pin and 40-pin flex connectors. Remove the 20-pin and 40-pin ends of the flex cable from the transceiver leaving the 30-pin end attached to the interface board.
4. Loosen the screws for the two retainers holding the transceiver to the interface board. Slide one of the retainers away from the edge of the transceiver to free it.
5. Remove the transceiver from within the two retainers.
6. Detach the RF cable from the RF adapter plug. Unscrew the RF adapter plug from the transceiver.

VRS750 Reassembly

NOTE: Replace all gaskets at each servicing to ensure proper sealing of unit.

Transceiver Reassembly

1. Screw the RF adapter plug into the transceiver. Tighten until the stop on the adapter is fully seated in the RF jack.
2. Connect the RF coax cable to the RF adapter.
3. Place the transceiver in between the two retainers, sliding one sideways if needed.
4. Adjust the retainers so that they align with the groove between the transceiver board and its chassis. Tighten the four screws of the retainers. If needed, adjust the screws so that the transceiver lays flat against the interface board.
5. Connect the 20-pin and 40-pin ends of the flex cable to the flex connector. Gently close the clasps on the connectors.
6. Reattach the flex connector retainer, 4285168D01.
7. Turn over the board.
8. Connect the RF coax cable to the right-angle SMB connector on the interface board.

Interface Board Reassembly

1. Install a new gasket around the 25 pin connector and Antenna connector located on the board.
2. Check that the foam seal is correctly positioned on the 25 pin connector on the bottom side of the board.
3. Add the conductive insulator to the back of the regulator.
4. Insert the main board carefully at an appropriate angle (approximately 30°) into the chassis. Start, but do not torque down, screw number 6 per Figure 29 and Table 8.
5. Install the antenna retaining clip.
6. Attach the nylon washer to the regulator at screw hole number 4 as indicated in Figure 29.
7. Install the screws with 6-8 in-lbs of torque using a T-10 Torx driver per sequence shown in Figure 29 and Table 8.
8. Place a new cover gasket around the chassis ensuring that it is placed under the locking tabs and ledge at the front of the chassis (see Figure 30). To ensure that the gasket remains seated along the groove, twist the gasket between fingers down and toward the chassis on both sides of the chassis.
9. If chassis is being replaced, add the plastic insert and seal into the area at the back of the main chassis opposite the antenna connector.
10. Install the top cover by engaging the hooks on front of the chassis and rotating the cover back. Ensure that the side snaps on the cover are engaged.
11. Install the front cover gasket over the front of the chassis ensuring that the rectangular hole in the chassis aligns with the rectangular hole in the gasket. Press the gasket flush against the chassis to ensure proper sealing.

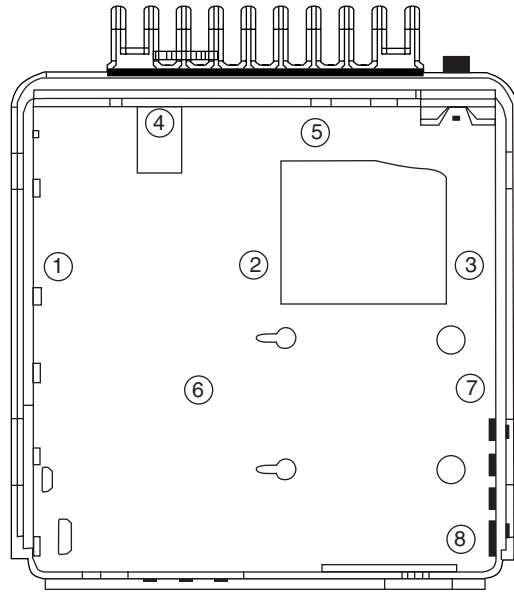

Figure 29. VRS750 Torque Sequence

Table 8. VRS750 Torque Sequence

Step	No.	Screw P/N	Bit	Torque	Notes
1	6	0310907A20	Torx T10	—	Start Only
2		—	—	—	Place Antenna Conn.
3	4-8	0310907A20	Torx T10	8 in-lb	Number 6 Inclusive
4	1-3	0310907A20	Torx T10	8 in-lb	

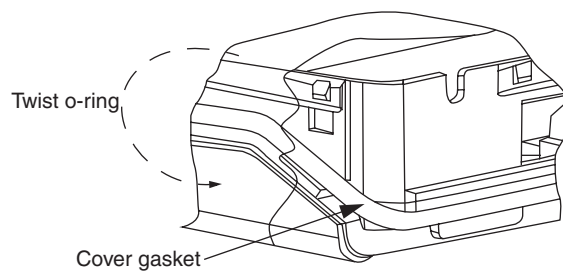

Figure 30. Cover Gasket Location

Assembly of Front Cover to Main Chassis

Refer to exploded views on page 88 for parts referenced in this procedure.

1. Install the 18 pin connector into the female connector (mounted on the PC board) through the hole in the front of the chassis.
2. Place white remote retainer (4205395X01) over the 18 pin connector.

3. Install the remote front housing over the 18 position connector onto the front of the chassis ensuring that both snaps are engaged.
4. Place the gasket within the recessed area for the 18-pin programming connector.
5. Connect the Programming Connector Cover to the main chassis.

VRS Transceiver

Field repair of the transceiver is not recommended. Contact your local service representative for a replacement transceiver. If replacement of the transceiver is necessary, refer to the Disassembly & Reassembly section and the Tuning Procedure section.

VRS Tuning and Alignment

The VRS is tuned at the factory and should not need to be realigned. Refer to the proper manuals for programming and alignment for the associated portable radio and mobile unit before attempting to troubleshoot the VRS unit. If proper tuning of the associated radio fails to correct a problem, the following procedure may be used to align the VRS.

Setup

ASTRO Spectra Station Cable Setup

Ensure that the ASTRO Spectra B+ cable is disconnected from the power supply and the control head is off (**WARNING: Never turn B+ power off with the control head still on.**) Connect the VRS DB-25 cable (HKN6153A) into the accessory connector of the mobile. Connect the other end of the VRS cable to the VRS. Set the test station power supply to 13.8 Vdc and current limiter to 12 amps. Connect the mobile's B+ cable to the power supply (see Figure 31).

Tuning Procedure

Interface Board Tuning Procedure

1. Place the VRS in the test mode:
 - a. Turn off the mobile radio control head.
 - b. Place the VRS into Test Mode by setting dipswitch S1 pins 1, 2, 3, and 4 to OFF.
 - c. Turn on the mobile control head and re-enable the VRS.
 - d. While in Test Mode, the VRS will not have portable priority interrupt and will not transmit PL with VRS-to-portable transmissions.
 - e. Figure 32 illustrates the relative placement of the tuning potentiometers.
2. Adjust the VRS Deviation Level:
 - a. Set the Mobile Communications Analyzer RF output to -50 dBm, with a standard test modulation (1 kHz tone, 3 kHz deviation).

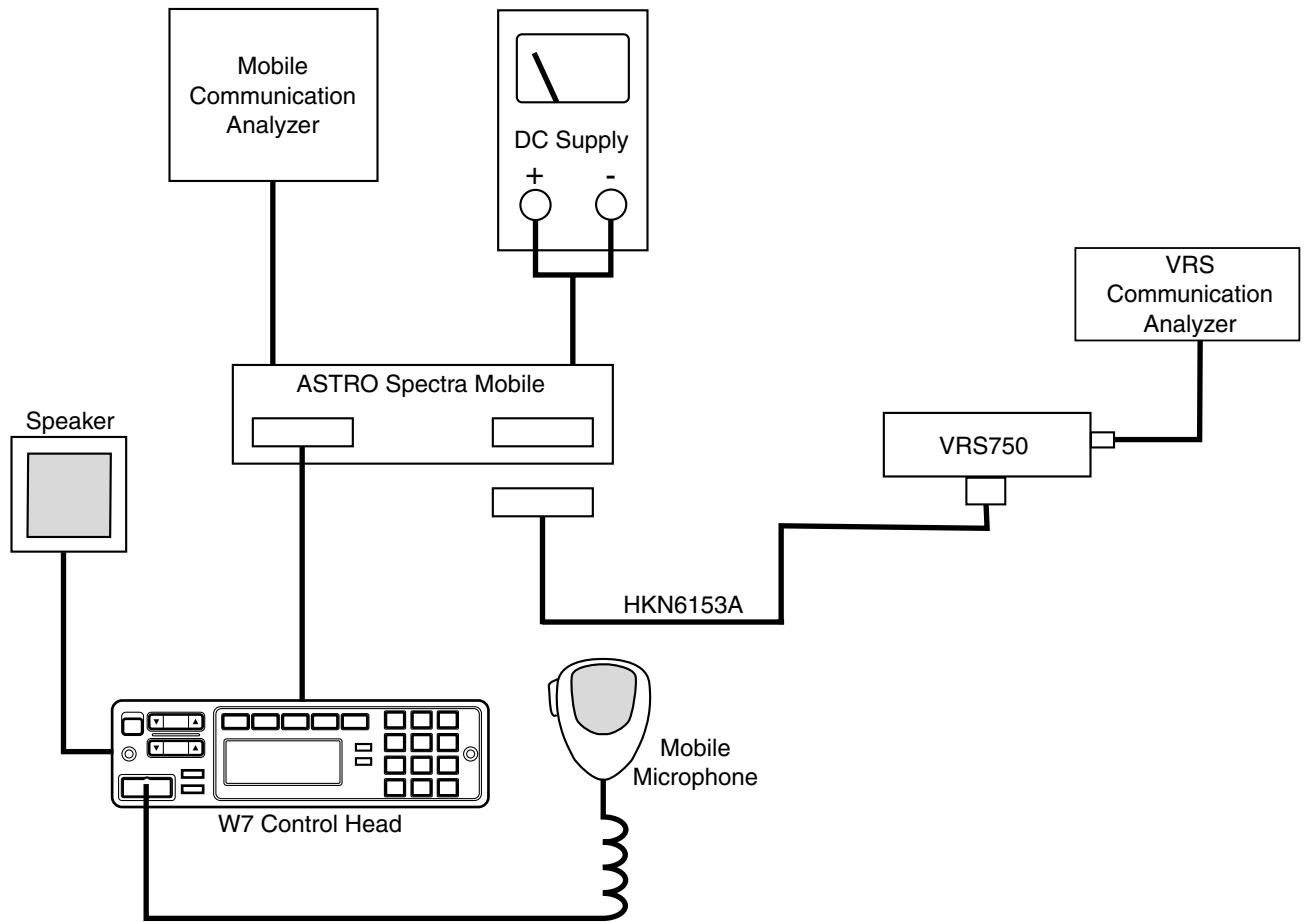

Figure 31. General Cabling Diagram

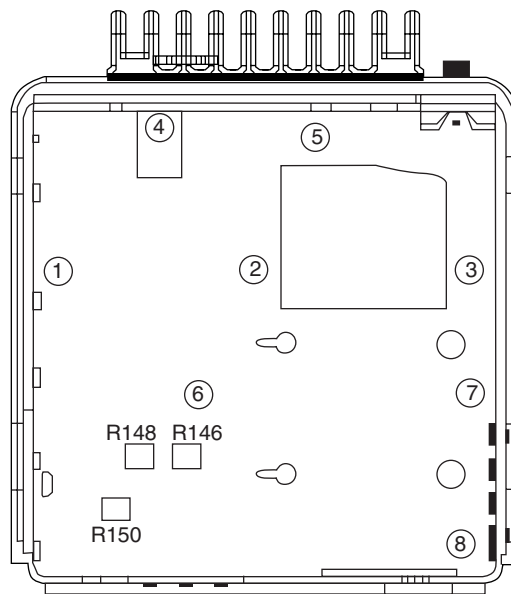

Figure 32. Tuning Potentiometers

- b. Set the Mobile Communications Analyzer frequency to the current mobile mode.
 - c. Switch on the Mobile Communications Analyzer RF.
 - d. Adjust R150 on the VRS board until 3.0 kHz deviation is obtained on the VRS Communications Analyzer.
 - e. Switch off the Mobile Communications Analyzer RF.
3. Adjust the Mobile Microphone Deviation Level:
- a. Inject a 1 kHz tone at 80 mVrms into the mobile microphone.
 - b. Key the mobile microphone. (Refer to the ASTRO Spectra Mobile service manual for specialized equipment.)
 - c. Adjust the signal level of the 1 kHz tone until 3.0 kHz deviation is obtained on the Mobile Communications Analyzer.
 - d. Adjust R148 on the VRS board until 3.0 kHz deviation is obtained on the VRS Communications Analyzer.
 - e. Dekey the mobile microphone.
4. Adjust the Mobile Deviation Level:
- NOTE:* Set the VRS Communications Analyzer RF output to -50 dBm with a standard test modulation (1 kHz tone, 3 kHz deviation) and any receive PL for which the VRS is programmed (750 Hz deviation). If the receive PL for “select mode” is not used, the Mobile Communications Analyzer frequency may need to be adjusted.
- a. Set the Mobile Communications Analyzer frequency to the current mobile mode.
 - b. Switch on the VRS Communications Analyzer RF.
 - c. Adjust R146 on the VRS board until 3.00 kHz deviation is obtained on the Mobile Communications Analyzer.
 - d. Switch off the VRS Communications Analyzer RF.
5. Check the VRS RF Sensitivity:
- a. Set the VRS Communications Analyzer RF output to -115 dBm with a standard test modulation (1 kHz tone, 3 kHz deviation) and any receive PL for which the VRS is programmed (750 Hz deviation).
- NOTE:* If the receive PL for “select mode” is not used, the Mobile Communications Analyzer frequency may need to be adjusted.
- b. Switch on the VRS Communications Analyzer RF. The unit should not retransmit this signal to the Mobile Communications Analyzer.
 - c. Slowly increase the input signal. The unit should begin repeating to the Mobile Communications Analyzer at no more than -104 dBm.

- d. Switch off the VRS Communications Analyzer RF.
6. Take the VRS out of test mode:
 - a. Turn off mobile control head and set the dipswitch S1 pins 1, 2, 3, and 4 to ON.
 - b. Turn on the mobile control head and re-enable the VRS.
7. Tuning is complete.

Transceiver Board Tuning Procedure

The transceiver board can be tuned using the Global Tuner when the VRS750 is in ATE Test Mode. Connect the VRS750 to the test box (RLN6394A) instead of the ASTRO Spectra mobile using the VRS750 ATE Cable (3080384N02) as shown in Figure 33. Before applying power, set dipswitch S1 pin 1 to ON and pins 2, 3, and 4 to OFF. This configures the VRS750 for ATE Test Mode. Make the appropriate connections to the VRS750 test box for power and audio. Once this is complete the VRS750 can be tested and tuned using the Global Tuner.

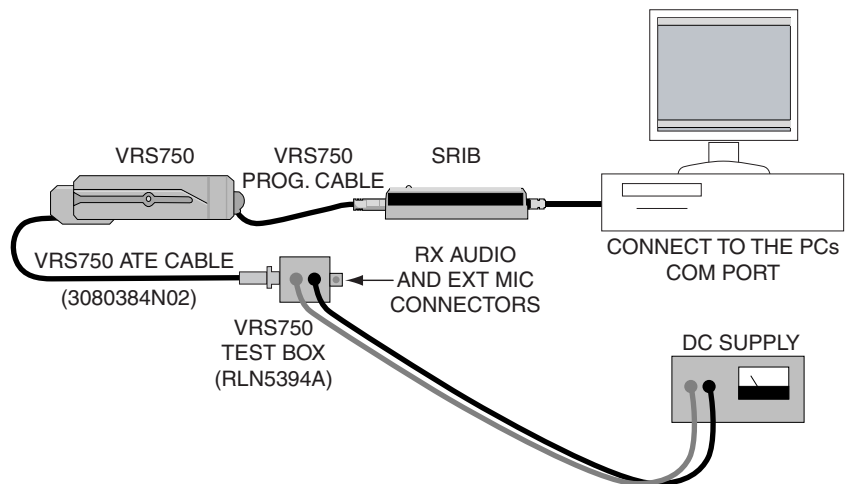

Figure 33. ATE Test Mode Configuration

Front End Filter Tuning

NOTE: Tuning is normally not required for VHF radios. It should only be performed if a radio has poor sensitivity. VHF radios are only tuned at one softpot frequency (F3: The values for the untuned frequencies are determined by adding the offset, calculated by subtracting the default softpot value for frequency F3 from the tuned softpot value for frequency F3. The default softpot values are listed in Table 9.)

Table 9. Default Softpot Values for VHF and UHF

Frequency Point	Softpot Value (Decimal)	
	VHF	UHF
F1	36	38
F2	57	48
F3	84	79
F4	124	110
F5	166	135
F6	195	161
F7	225	186

Under **Rx Align**, select the **Front End Filter** option.

1. Inject a -70 dBm RF Signal with Frequency F1 (for UHF)/F3 (for VHF) modulated with 1 kHz tone at 60% rated deviation (see Table 10) into the VRS750. A 1 kHz tone must be detected at the RX Audio connector on the test box to verify that the radio is receiving.
2. Measure the RSSI voltage with a DC voltmeter capable of 1 mV resolution at test point 111 on the VRS750. It is recommended that an RCA filter (1.5 K-47 uF) be added at the input of the voltmeter to reduce RSSI noise.
3. Increment the softpot value by adjusting the slider, keying in the softpot values in the edit box (press ENTER to confirm selection) or using the spin control until the **maximum RSSI voltage** has been achieved.
4. For UHF and VHF radios:
 - a. **UHF radios:** Choose the next frequency and repeat steps 1 to 3 until all seven tuning points are done.
 - b. **VHF radios:** Calculate the softpot offset by subtracting the default softpot value for F3 from the tuned softpot value for F3. Add the calculated offset to all default values and enter the results in the edit boxes for the appropriate softpot frequencies.
5. Press **Program** to commit the softpot values into the codeplug.

Table 10. VRS750 Deviation Levels

Channel Spacing (kHz)	Rated System Deviation (kHz)	Signal Generator Deviation (kHz)
12.5	2.5	1.5
20	4.0	2.4
20	5.0	3.0
25	5.0	3.0
30	5.0	3.0

Rated Volume Tuning

Under Rx Align, select **Rated Volume**.

NOTE: The received audio output is taken from the positive terminal of C189.

1. Inject a -47 dBm RF Signal modulated with 1 kHz tone at the 60% rated deviation (see Table 10) into the VRS750.
2. Adjust the softpot value by using the slider, keying in the edit box (press **ENTER** to confirm selection/send a softpot value), or via the spin controls. Repeat this until a **1.58 Vrms ±200 mVrms** signal can be obtained at the positive terminal of C189.
3. Press **Program** to commit the softpot value into the codeplug.

NOTE: Perform this operation prior to all other transmit tuning operations in order to minimize heating and because of the impact of warp on signaling operations.

Reference Oscillator Warp

1. Under **Tx Align** menu, select **Reference Oscillator Warp**.
2. There is only 1 frequency point shown which is always the last non 0 transmit frequency point, which will normally be F7.
3. Click on the slider thumb. Press **PTT Toggle** to key up the radio at the corresponding frequency point.
4. Monitor the transmit frequency.
5. Adjust the slider, spin or edit control (press **ENTER** to confirm selection/send a softpot value) until the frequency is as close as possible to the indicated transmit frequency (refer to Table 11).

Table 11. Frequency Error Specifications

RF Band	Target (Hz)
VHF (136-174)	±200
UHF Band 1 (403-470)	±200
UHF Band 2 (450-527)	±200

6. Dekey the radio by pressing **PTT Toggle**.

7. Program the warp value into the radio by pressing the **Program** button.
8. Exit the Reference Oscillator Warp function.

VCO Attenuation

NOTE: The Transmit Deviation Limit softpot sets the maximum deviation of the carrier. Tuning is performed for 12.5 kHz, 20 kHz, and 25 kHz channel spacing. Tuning for 25 kHz channel must be done first for all frequency points. Tuning for 12.5 kHz and 20 kHz channel spacing determines only the offset to the previously tuned deviation for 25 kHz tuning channel spacing. For (12.5, 20 kHz) channel spacing, only the last non 0 transmit frequency point (normally F7) will be used for tuning.

VCO Attn. 25 kHz

1. Under the **Tx Align** menu, select **VCO Attn. 25 kHz**.
2. Begin with the lowest frequency. Select the thumb of the slider at the lowest frequency point and then press the **PTT Toggle** button to key up the radio at the corresponding frequency point. The spin control can also be toggled via its up/down arrow buttons. The softpot value can also be typed into the edit control (press **ENTER** to confirm selection/send a softpot value).
3. Inject a 1 kHz at 80 mVrms signal into the external mic connector on the test box (VRS750 input).
4. Note down the deviation obtained.
5. Adjust the slider, adjust the spin control or key in softpot values (press **ENTER** to confirm) for the frequency point until the deviation is within range as defined in Table 12.
6. Dekey radio (press the **PTT Toggle** button). Choose the next frequency, key up and repeat steps 3 to 6 until all seven tuning points are done.
7. Program the softpot value by pressing the **Program** button.
8. Exit the VCO Attn. 25 kHz function.

VCO Attn. 20 kHz

NOTE: Tuning of Modulation Balance Attn. and VCO Attn. for 25 kHz channel spacing must be done first.

1. Under the **Tx Align** menu, select **VCO Attn. 20 kHz**.
2. Press **PTT Toggle** to key up the radio at the last non 0 transmit frequency point (normally F7).
3. Inject a 1 kHz at 80 mVrms signal into the external mic connector on the test box (VRS750 input).
4. Note down the deviation obtained.
5. Adjust the slider, adjust the spin control or key in softpot values (press **ENTER** to confirm) for the frequency point until the deviation is within range as defined in Table 12.
6. Press **PTT Toggle** to dekey the radio.
7. Program the softpot value by pressing the **Program** button.

VCO Attn. 12.5 kHz

- Exit the VCO Attn. 20 kHz function.

NOTE: Tuning of VCO Attn. for 25 kHz channel spacing must be done first.

- Under the **Tx Align** menu, select **VCO Attn. 12.5 kHz**.
- Press **PTT Toggle** to key up the radio at the last non 0 transmit frequency point (normally F7).
- Inject a 1 kHz at 80 mVrms signal into the external mic connector on the test box (VRS750 input).
- Note down the deviation obtained.
- Adjust the slider, adjust the spin control or key in softpot values (press **ENTER** to confirm) for the frequency point until the deviation is within range as defined in Table 12.
- Press **PTT Toggle** to dekey the radio.
- Program the softpot value by pressing the **Program** button.
- Exit the VCO Attn. 12.5 kHz function.

Table 12. Deviation Specifications for VRS750 UHF/VHF Radios

Band	Channel Spacing (kHz)	Deviation (kHz)
UHF/VHF	12.5	2.20-2.30
UHF/VHF	20	3.40-3.60
UHF/VHF	25	4.40-4.60

PA Bias Tuning UHF/VHF VRS750s (Procedure 1)

IMPORTANT NOTE: Tuning must be performed for both High and Low power for UHF and VHF radios. Take note that Procedure 1 IS NOT TO BE PERFORMED for UHF low power level tuning. Please refer to Procedure 2.

- Ensure that the radio's antenna output is terminated to a **50 Ohm load**. This is to prevent self destruction of the PA.
- Under **Tx Align**, select **PA Bias**, select **High Power**.
- Measure/read the dc current drawn from radio (specifications will vary from radio to radio). Call this X. This value should typically range from 70-100 mA or 0.07-0.1 A.
- Press **Toggle Voltage** to enable the PA control voltage edit box/spin control.
- Increase the Voltage softpot value and measure/read from current meter. Call the new value Y.
- Increase Y until Y-X is within the range given for PA current in Table 13.
- Press **Toggle Voltage** again to disable the PA control voltage edit box/spin control.

8. Press **Toggle Bias 1** in order to enable the PA Bias softpot.
9. Increase the softpot value to obtain **Z** until **Z-Y** is within the range for Bias Current as indicated in Table 13.
10. Press **Toggle Bias 1** again to disable the PA Bias softpot.
11. Program the Bias softpot into the radio's codeplug via pressing **Program**.
12. Exit the PA Bias High Power function.
13. Under **Tx Align**, select **PA Bias, Low Power**. (If UHF, skip to step 15 and continue to Procedure 2.)
14. Repeat steps 3-11.
15. Exit the PA Bias Low Power function.

Table 13. PA Bias High Power Specifications UHF/VHF VRS750s

RF Band	PA Current (mA)	Bias Current (mA)
VHF	90-110	90-110
UHF Band 1	30-45	600-700
UHF Band 2	30-55	400-480

PA Bias Tuning for UHF Low Power VRS750s (Procedure 2)

NOTE: Failure in the instructions below means that you cannot get a reading which is within the range of the current window as specified in Table 14 for each individual step.

Ensure that the radio's antenna output is terminated to a **50 Ohm load**. This is to prevent self destruction of the PA.

STEP 1

1. Under **Tx Align**, select **PA Bias**, select **Low Power**.
2. Measure/read the dc current drawn from radio (specifications will vary from radio to radio). Call this **X**. This value should typically range from 70-100 mA or 0.07-0.1 A.
3. Press **Toggle Voltage** to enable the PA control voltage edit box/spin control.
4. Increase the Voltage softpot value and measure/read from current meter. Call the new value **Y**.
5. Increase **Y** until **Y-X** is within the range given for PA current in Table 14 (**STEP 1**) below.

******* If a failure occurs, go to STEP 2 otherwise proceed**

6. Press **Toggle Voltage** again to disable the PA control voltage edit box/spin control.
7. Press **Toggle Bias** in order to enable the PA Bias softpot.
8. Increase the softpot value to obtain **Z** until **Z-Y** is within the range for Bias Current as indicated in Table 14 (**STEP 1**).

***** If a failure occurs, go to STEP 3 otherwise proceed

9. Press **Toggle Bias** again to disable the PA Bias softpot.
10. Program the Bias softpot into the radio's codeplug via pressing **Program**.
11. Exit the PA Bias Low Power function.

STEP 2

1. Increase Y until Y-X is within the range given for PA current in Table 14 (STEP 2).
2. Press **Toggle Voltage** again to disable the PA control voltage edit box/spin control.
3. Press **Toggle Bias** in order to enable the PA Bias softpot.
4. Increase the softpot value to obtain Z until Z-Y is within the range for Bias Current as indicated in Table 14 (STEP 2).

***** If a failure occurs, go to STEP 3 otherwise proceed

5. Press **Toggle Bias** again to disable the PA Bias softpot.
6. Program the Bias softpot into the radio's codeplug via pressing **Program**.
7. Exit the PA Bias Low Power function.

STEP 3

1. Press **Toggle Bias** twice to reset the softpot value.
2. Press **Toggle Bias** again to disable the PA Bias softpot.
3. Measure/read the dc current drawn from radio (specifications will vary from radio to radio). Call this X. This value should typically range from 70-100 mA or 0.07-0.1 A.
4. Press **Toggle Voltage** to enable the PA control voltage edit box/spin control.
5. Increase the Voltage softpot value and measure/read from current meter. Call the new value Y.
6. Increase Y until Y-X is within the range given for PA current in Table 14 (STEP 3).
7. Press **Toggle Voltage** again to disable the PA control voltage edit box/spin control.
8. Press **Toggle Bias** in order to enable the PA Bias softpot.
9. Increase the softpot value to obtain Z until Z-Y is within the range for Bias Current as indicated in Table 14 (STEP 3).

Table 14. PA Bias Low Power Specification for VRS750s (UHF Only)

Step	PA Current (mA)	Bias Current (mA)
STEP 1	20-30	630-750
STEP 2	30-45	750-900
STEP 3	40-55	600-750

10. Press **Toggle Bias** again to disable the PA Bias softpot.
11. Program the Bias softpot into the radio's codeplug via pressing **Program**.
12. Exit the PA Bias Low Power function.

NOTE: After tuning a transceiver, go back and tune the interface board (details in this chapter) and then adjust the output power and squelch settings (see Chapter 2).

Troubleshooting Charts

8

Introduction to this Section

This section contains detailed troubleshooting flowcharts. These charts should be used as a guide in determining problem areas. They are not a substitute for knowledge of circuit operation and astute troubleshooting techniques. It is advisable to refer to the related circuit descriptions in the “Hardware Detailed Theory of Operation,” Chapter 6.

List of Troubleshooting Charts

Chart Number	Description	Page Number
1	VRS Enable Failure	68
2	Error 12/10	69
3	Error 12/81	69
4	Error 12/82, Codeplug Checksum Error*	69
5	Error 12/84, Configuration Register Corruption*	69
6	Error 12/88, HC11 RAM Failure	69
7	VRS 001, VRS Synthesizer Lock Failure	70
8	Single Tone Encode Failure	71
9	Single Tone Failure	72
10	Base-to-Portable Repeat Failure	73
11	Portable-to-Base Repeat Failure	74
12	VRS ICM Audio Failure	75
13	Serial Bus Failure	76
14	Portable Audio at Local Speaker Issue	77
15	Programming/Tuning Failure	78

*Older VRS-EP versions may show a 12/82 Error flashing every 5 seconds for Codeplug Checksum Error, and a 12/82 Error at power-up only for Configuration Register Corruption.

VRS ENABLE FAILURE

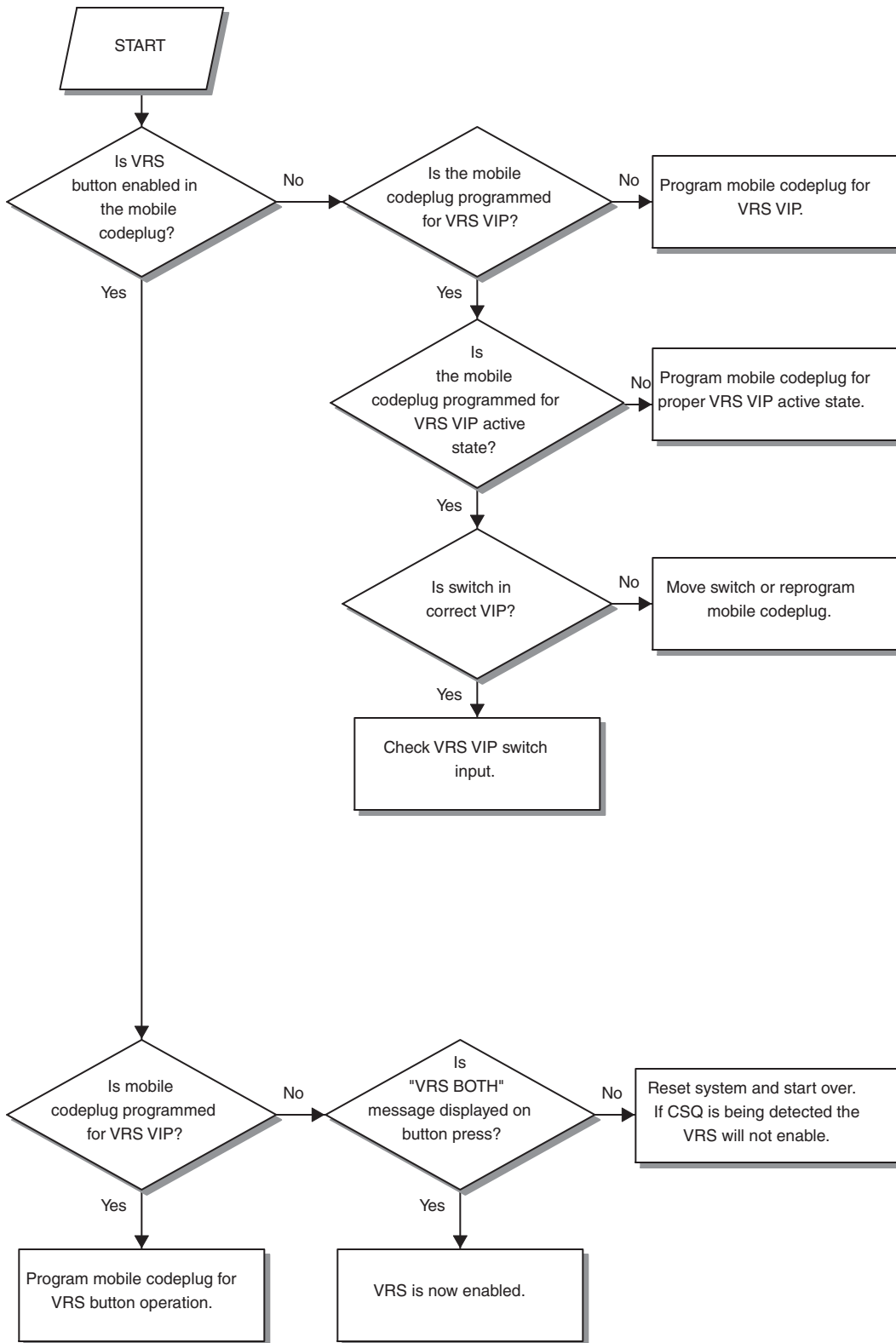

Chart 1—VRS Enable Feature

ERROR 12/10

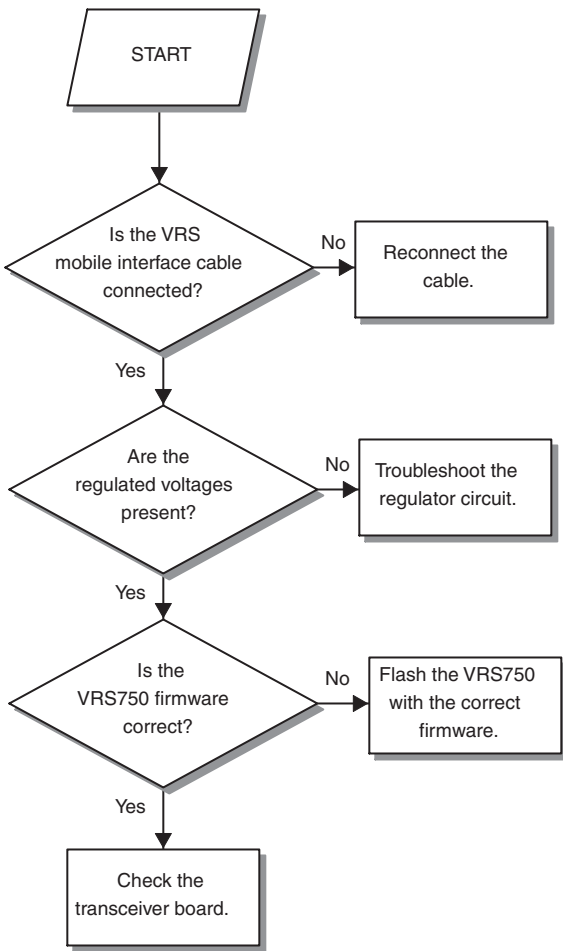

Chart 2—Error 12/10

ERROR 12/84

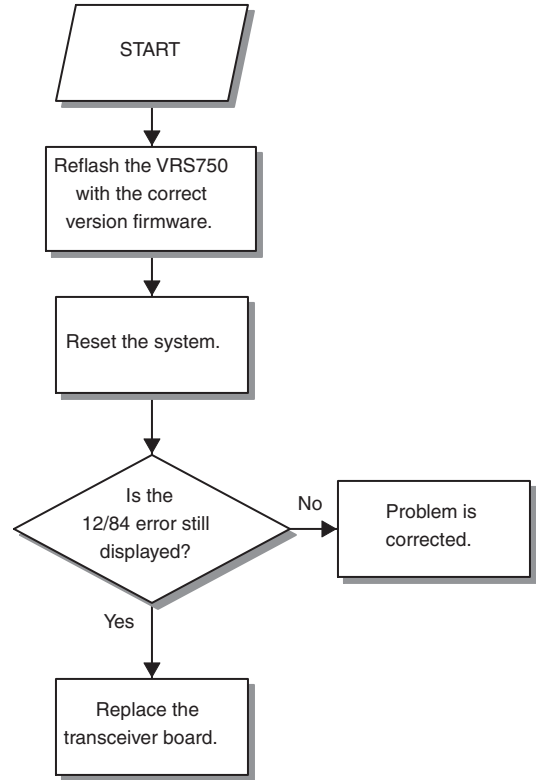

Chart 5—Error 12/84, Configuration Register Corruption

ERROR 12/81

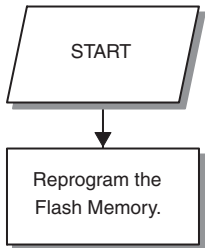

Chart 3—Error 12/81

ERROR 12/82

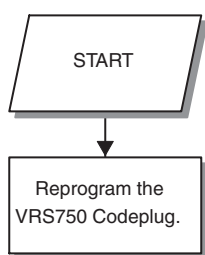

Chart 4—Error 12/82, Codeplug Checksum Error

ERROR 12/88

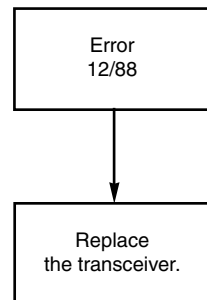

Chart 6—Error 12/88, HC11 RAM Failure

VRS 001 FAILURE

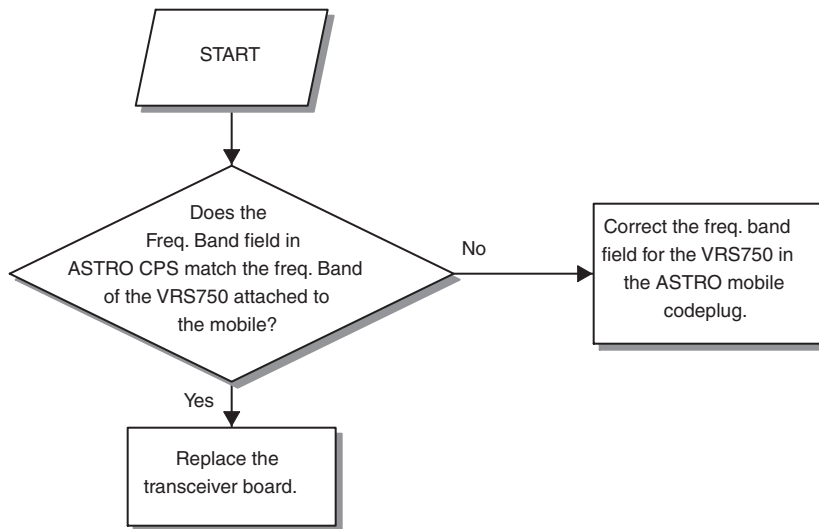

Chart 7—VRS 001, VRS Synthesizer Lock Failure

SINGLE TONE ENCODE FAILURE

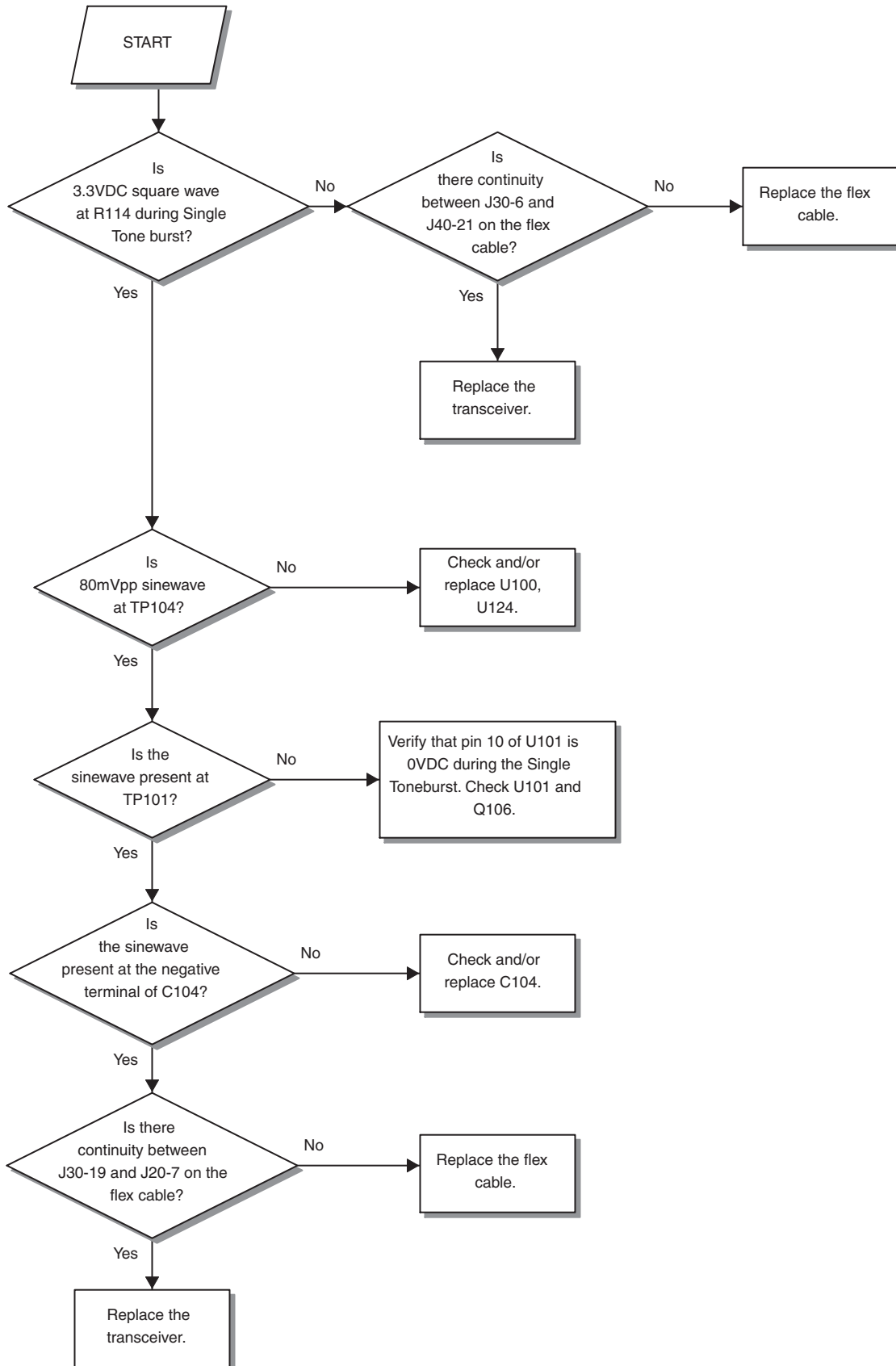

Chart 8—Single Tone Encode Failure

SINGLE TONE FAILURE

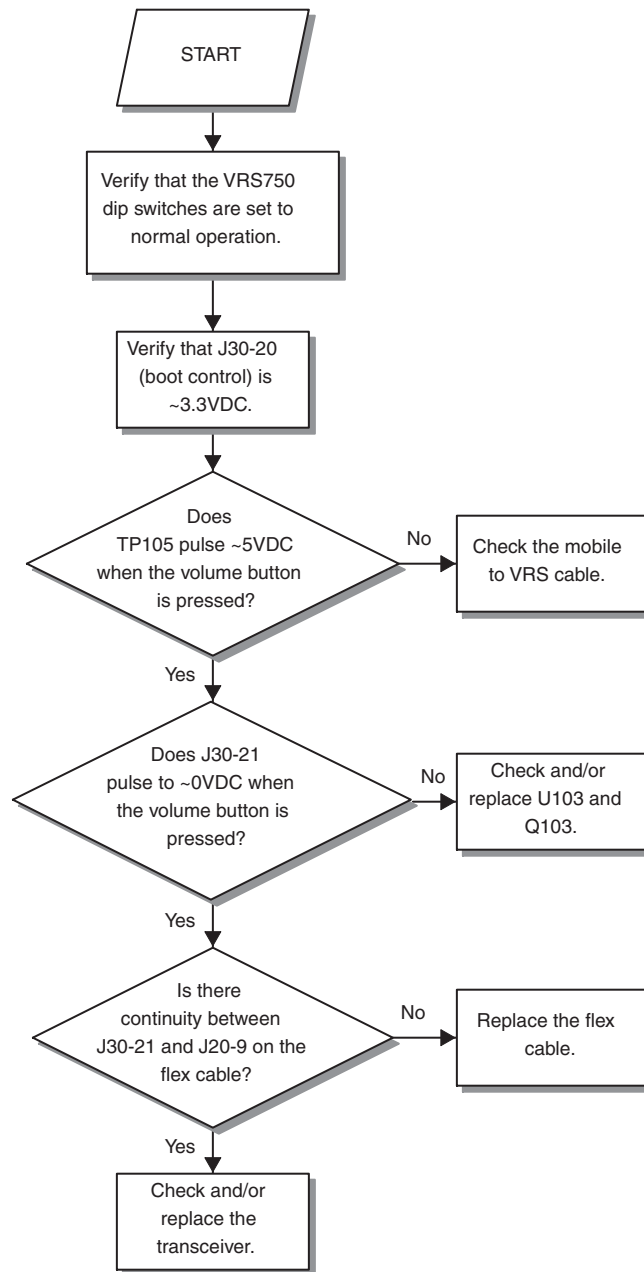

Chart 9—Single Tone Failure

BASE TO PORT. AUDIO ISSUES



Chart 10—Base-to-Portable Repeat Failure

PORTABLE-TO-BASE AUDIO ISSUE

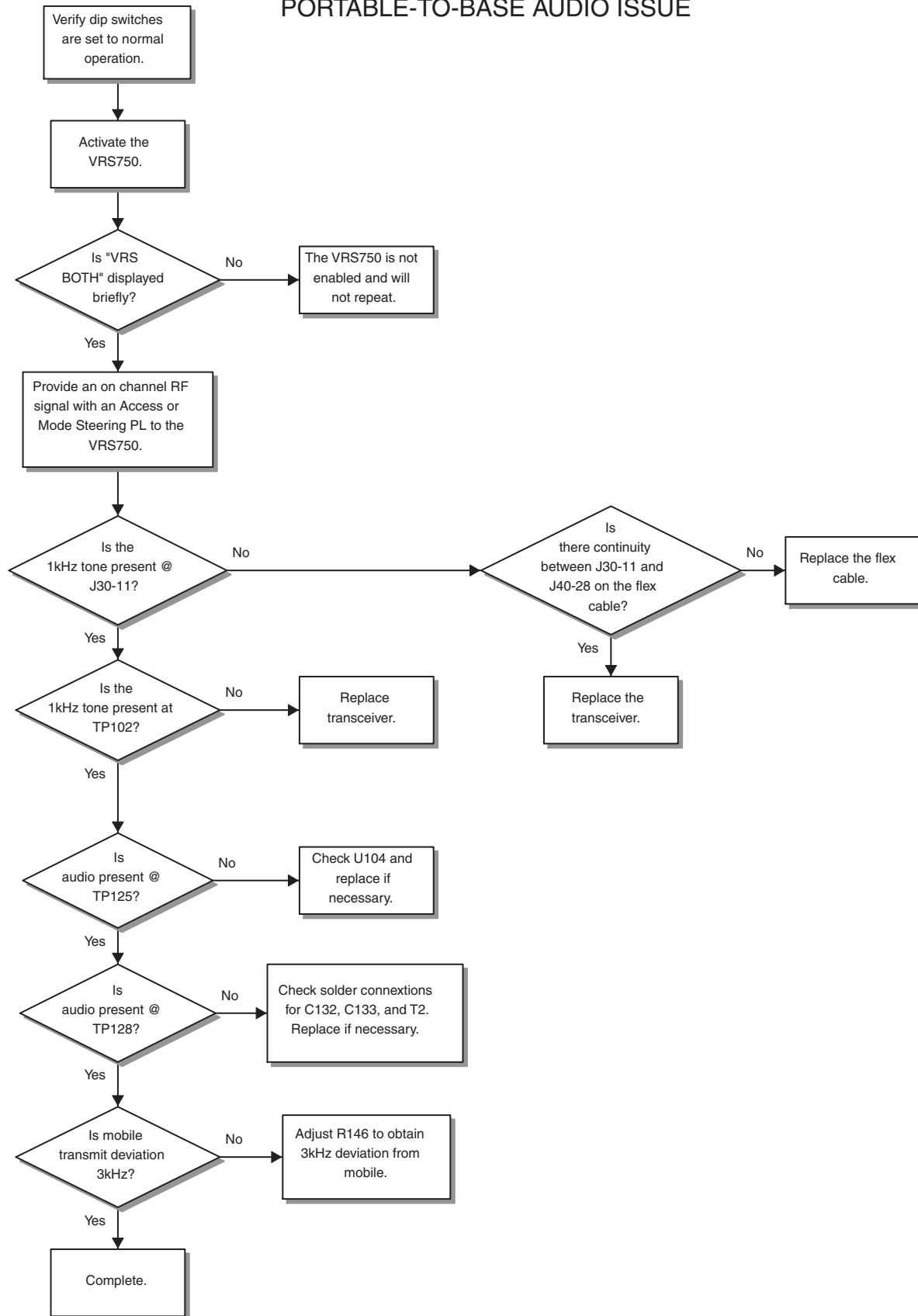

Chart 11—Portable-to-Base Repeat Failure

IN-CAR-MONITOR AUDIO ISSUES

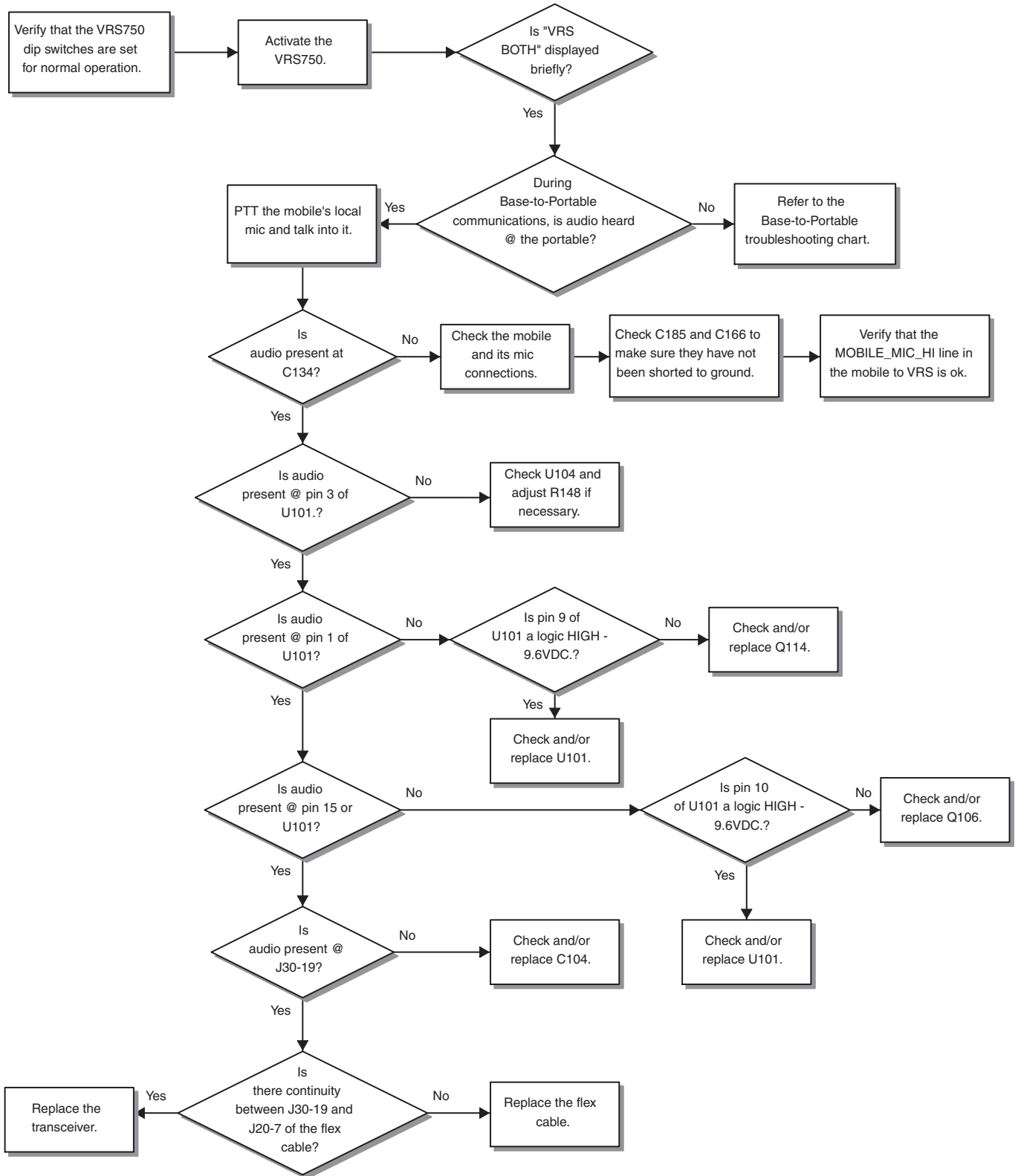

Chart 12—VRS ICM Audio Failure

SERIAL BUS FAILURE

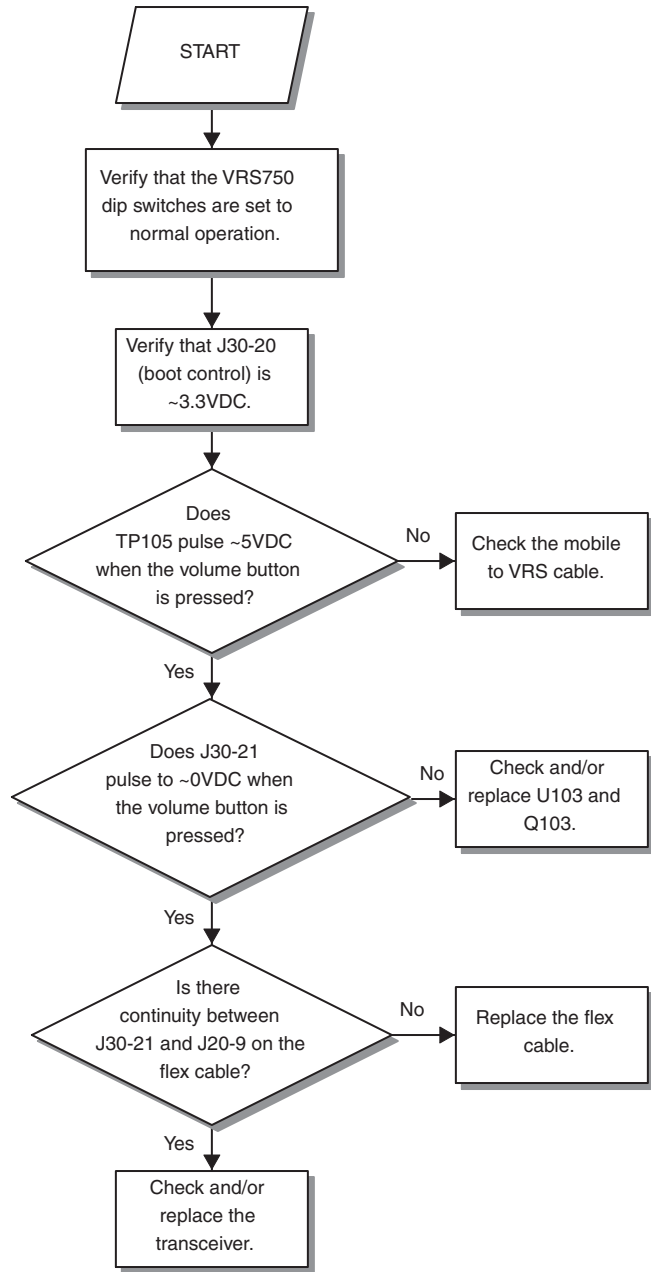

Chart 13—Serial Bus Failure

PORTABLE AUDIO AT LOCAL SPEAKER ISSUE

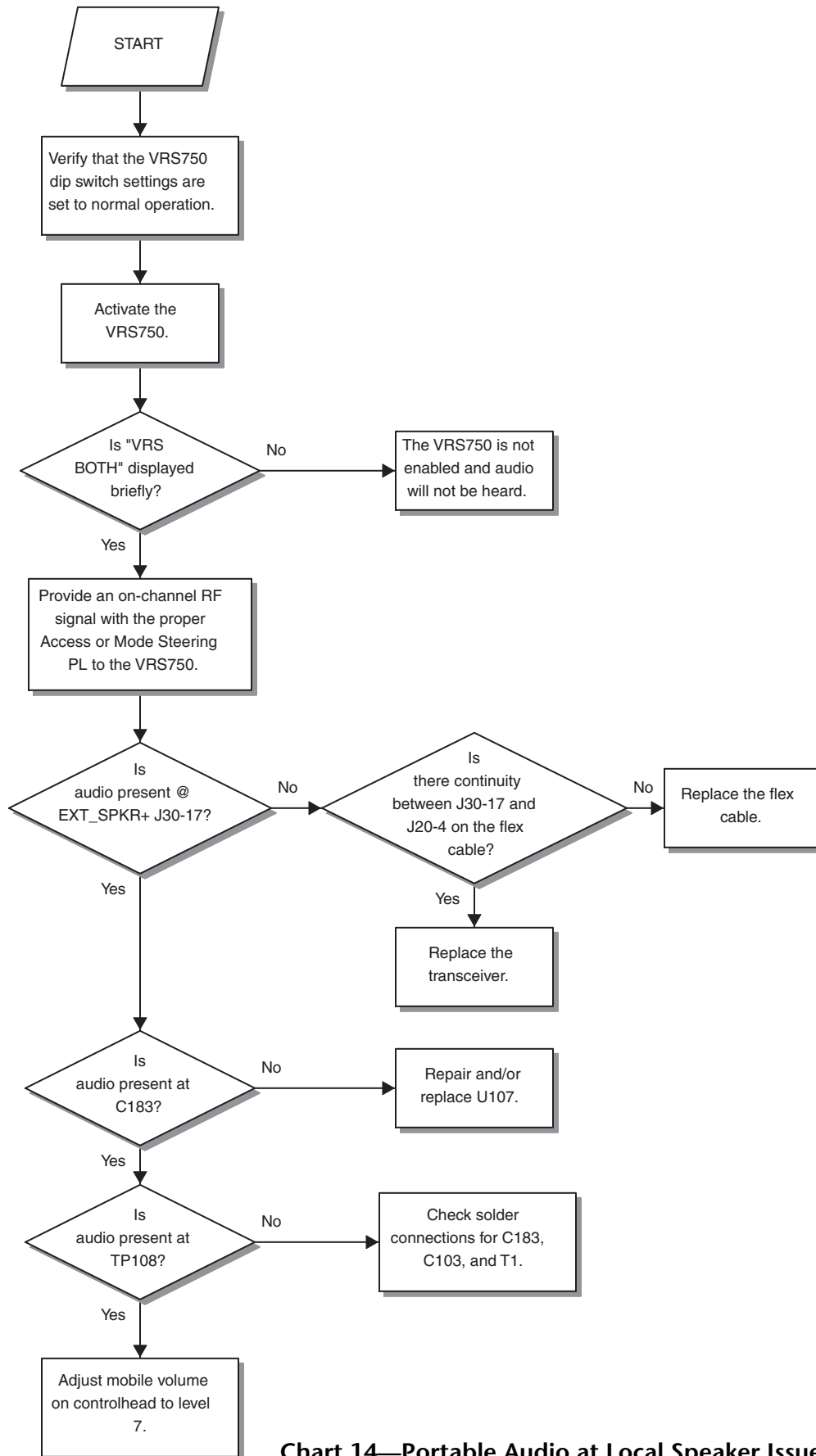

Chart 14—Portable Audio at Local Speaker Issue

PROGRAMMING AND TUNING ISSUES

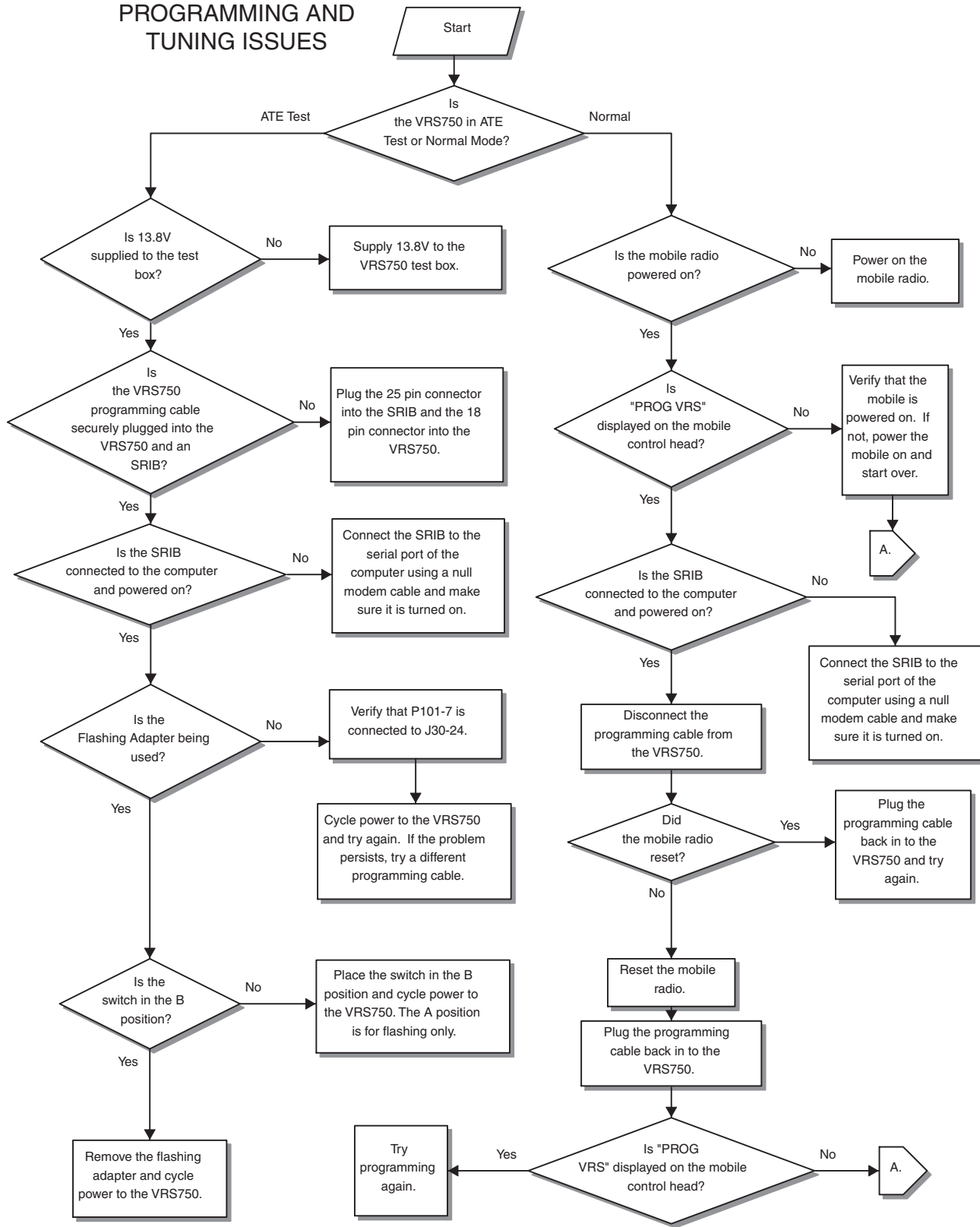

Chart 15—Programming/Tuning Failure

PROGRAMMING AND TUNING ISSUES (CONT.)

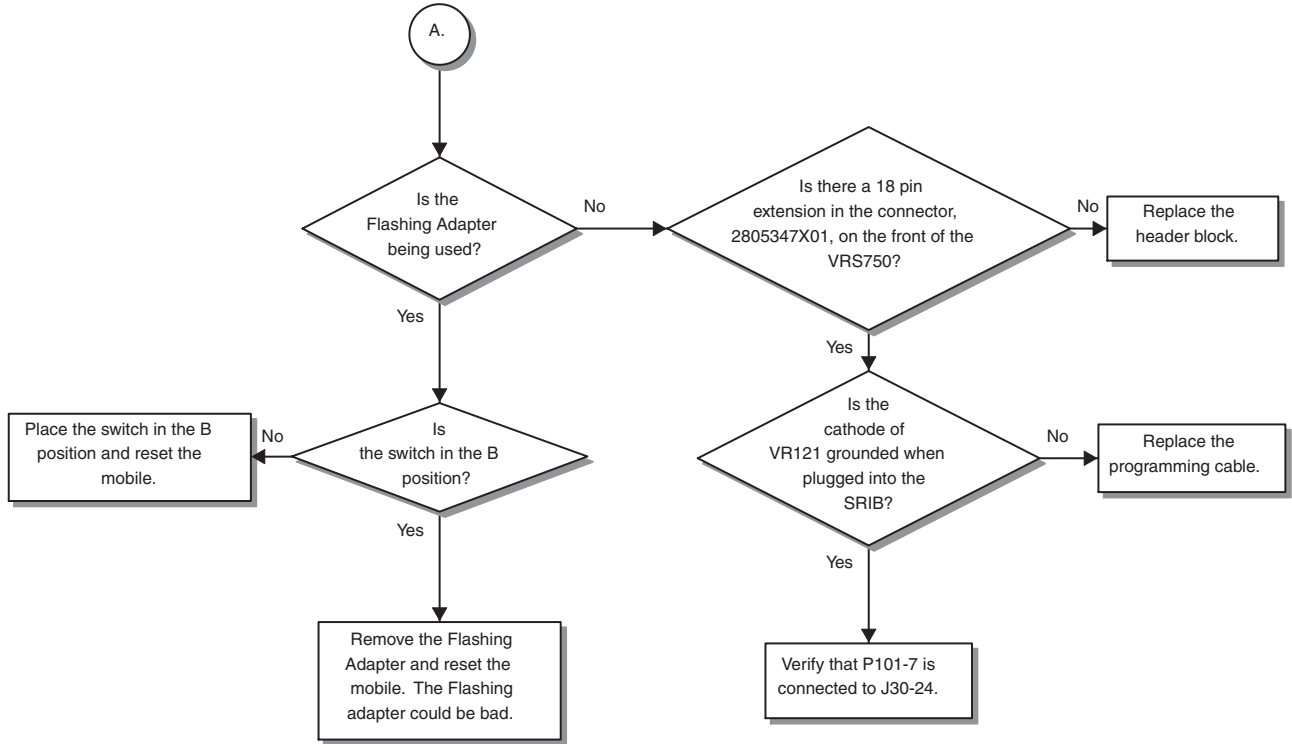

Chart 15—Programming/Tuning Failure (Cont.)

Diagrams and Parts Lists

9

Introduction to this Section

This section contains schematics, a component layout diagram, an exploded view, and electrical and exploded view parts lists.

List of Diagrams and Parts Lists

Description	Page Number
Printed Circuit Board Electrical Parts List	83
Printed Circuit Board Component Location Diagram	84-85
Printed Circuit Board Schematic Diagram	86-87
Exploded View and Exploded View Parts List	88
VRS-to-Mobile Cable	89
VRS-to-Siren Cable	89
VRS750 Programming Cable	90
VRS750 Programming Cable Schematic Diagram	90
VRS750 Flashing Adapter Schematic Diagram	90

**VRS750 Vehicular Repeater System
Printed Circuit Board Electrical Parts List
(PLN7780A)**

ITEM	MOTOROLA PART NUMBER	DESCRIPTION
		CAPACITOR, Fixed; pF: unless otherwise stated
C100	2113740F59	220
C101	2113740F39	33
C102	2113740F59	220
C103, 104	2311049A08	Polar, 1 µF
C105	2113741B69	0.1 µF
C107	2113740F59	220
C108	2113741B69	0.1 µF
C109	2113740F59	220
C111, 112	2113740F59	220
C113	2113741F33	2200
C114 thru 116	2113741A45	.01 µF
C117	2113741A49	.015 µF
C118	2113740A79	1000
C119	2113743B21	0.22 µF
C120	2113741B69	0.1 µF
C121	2113740B49	100
C122 thru 131	2113740F59	220
C132, 133	2311049A08	Polar, 1 µF
C134, 135	2113743E20	0.1 µF
C136	2113740F59	220
C137	2380090M40	Polar, 2200 µF
C138, 139	2113740F59	220
C140	2113743E20	0.1 µF
C141	2113741A45	.01 µF
C142	2113740F59	220
C143	2113741B69	0.1 µF
C145	2113740A79	1000
C146, 147	2113740F59	220
C148	2311049A08	Polar, 1 µF
C149	2311049A19	Polar, 10 µF
C150	2113740F59	220
C151	2311049A19	Polar, 10 µF
C152	2113740F59	220
C153	2311049A19	Polar, 10 µF
C154	2113740F59	220
C155	2311049A19	Polar, 10 µF
C156	2380090M25	Polar, 100 µF
C157 thru 161	2113740F59	220
C162	2380090M25	Polar, 100 µF
C164 thru 167	2113740F59	220
C168	2113743E20	0.1 µF
C170	2113740F59	220
C171	2113743E20	0.1 µF
C172, 173	2113740F59	220
C175	2113740F59	220
C179	2113740F59	220
C180	2113740A79	1000
C182	2311049A19	Polar, 10 µF
C183	2311049A08	Polar, 1 µF
C184	2113740F59	220
C185	2113743A13	0.047 µF
C188	2113740F59	220
C189	2311049A08	Polar, 1 µF
C190	2113741F21	680
C191	2113740F59	220
C194	2113740A79	1000
C195	2113740F59	220
C196	2113743E20	0.1 µF
C197	2113740F59	220
C198	2113743E20	0.1 µF
C199	2113740F59	220
C200	2113743E20	0.1 µF
C201 thru 208	2113740F59	220
		DIODE: See Note 1
D100, 101	4813825A08	MBD701
D102	4813832C77	Transient suppressor, 24 V

ITEM	MOTOROLA PART NUMBER	DESCRIPTION
F100	6580542Z01	FUSE: 3 A
J30	0985173D01	JACK: Connector, 30 pin flex
L101	2505462S03	COIL, RF: Inductor, 1000 µH
P101	0905904V02	PLUG: Connector, J
P102	2805429W03	Connector, P
		TRANSISTOR: See Note 1
Q100, 101	4880141L02	NPN
Q102	4813824A17	PNP
Q103	4880141L02	NPN
Q104	4813824A17	PNP
Q106	4880141L02	NPN
Q109 thru 112	4880141L02	NPN
Q113	4813821A21	nchan_tmosfet_gsd
Q114, 115	4880141L02	NPN
		RESISTOR: Ohms ±5%; 1/8 W unless otherwise stated
R101	0662057A93	68 k
R102	0662057A73	10 k
R104, 105	0662057A25	100
R106	0662057A65	4.7 k
R107	0662057A69	6.8 k
R108	0662057A93	68 k
R109	0662057A97	100 k
R110	0662057A77	15 k
R111	0662057A83	27 k
R112, 113	0662057A97	100 k
R114	0662057B10	330 k
R115	0662057A94	75 k
R116	0662057A84	30 k
R117, 118	0662057A65	4.7 k
R119	0662057A69	6.8 k
R120, 121	0662057A73	10 k
R122, 123	0662057A83	27 k
R124	0662057A73	10 k
R125	0662057A91	56 k
R126	0662057A77	15 k
R127	0662057A73	10 k
R128	0662057P95	100 k, 1%
R129	0662057P27	27.4 k, 1%
R130	0662057P22	22.1 k, 1%
R131	0662057P95	100 k, 1%
R132, 133	0662057A65	4.7 k
R136, 137	0662057A73	10 k
R138	0662057A65	4.7 k
R139	0662057A49	1 k
R140, 141	0662057A65	4.7 k
R142	0662057A49	1 k
R143	0662057A65	4.7 k
R145	0662057A89	47 k
R146	1813905A11	Pot, 20 k
R147	0662057A65	4.7 k
R148	1813905A11	Pot, 20 k
R149	0662057A91	56 k
R150	1813905A11	Pot, 20 k
R151	0662057A97	100 k
R155	0662057A73	10 k
R156	0662057A49	1 k
R157	0662057A77	15 k
R158	0662057A38	360
R159	0662057A55	1.8 k
R160	0662057A77	15 k
R161	0662057A47	820
R162 thru 164	0662057A73	10 k

ITEM	MOTOROLA PART NUMBER	DESCRIPTION
R165	0662057A56	2 k
R166	0662057A65	4.7 k
R171	0662057T64	47.5 k 1%
R172, 173	0662057A73	10 k
R174	0662057P27	27.4 k, 1%
R175	0662057A73	10 k
R180, 181	0662057A65	4.7 k
R182	0662057A49	1 k
R183	0662057A73	10 k
R184	0662057A65	4.7 k
R200	0662057A65	4.7 k
R210	0662057A49	1 k
R211, 212	0662057A73	10 k
R213'	0662057A65	4.7 k
R215	0662057A83	27 k
R216	0662057B26	1.5 M
R217	0662057A49	1 k
R220	0662057B47	0
R221	0662057A81	22 k
R224	0662057A97	100 k
R225	0662057A73	10 k
R226, 227	0662057A65	4.7 k
R228, 229	0662057A73	10 k
		SWITCH: Dip
S1	4080564C02	
		TRANSFORMER: 6-pin
T1, T2	2584422T02	
		INTEGRATED CIRCUIT MODULE: See Note 1
U100	5113818A03	MC33072-1
U101, 102	5184704M60	MC14053B
U103	5113806A37	MC14106
U104	5113819A04	MC3303
U105	5184704M60	MC14053B
U107	5113818A03	MC33072-1
U111	5113816A03	MC78L05A
U118	5105109Z13	LT1129
U124	5113819A04	MC3303
U129	5105469E18	LM317T
		DIODE: See Note 1
VR102 thru 109	4805129M35	Zener, 13, 5.6 V
VR110	4813830A28	Zener, 13, 15 V
VR112, 113	4805129M35	Zener, 13, 5.6 V
VR115	4813830A28	Zener, 13, 15 V
VR118	4805129M35	Zener, 13, 5.6 V
VR121	4805129M35	Zener, 13, 5.6 V
VR123	4805129M35	Zener, 13, 5.6 V
		CONNECTOR: SMB Jack Rt. Ang PCB J, Antenna Connector
W101	0984345R02	
W102	0905901V10	
		MISCELLANEOUS: Board, PC Nut Screw
	8485176D01	
	0200835638	
	0300114832	

Notes:

- For optimum performance, order replacement diodes, transistors, and circuit modules by Motorola part number only.
- When ordering crystals, specify carrier frequency, crystal frequency, crystal type number, and Motorola part number.
- Part value notations:

p=10 ⁻¹²	µ=10 ⁻⁶	k=10 ³
n=10 ⁻⁹	m=10 ⁻³	M=10 ⁶

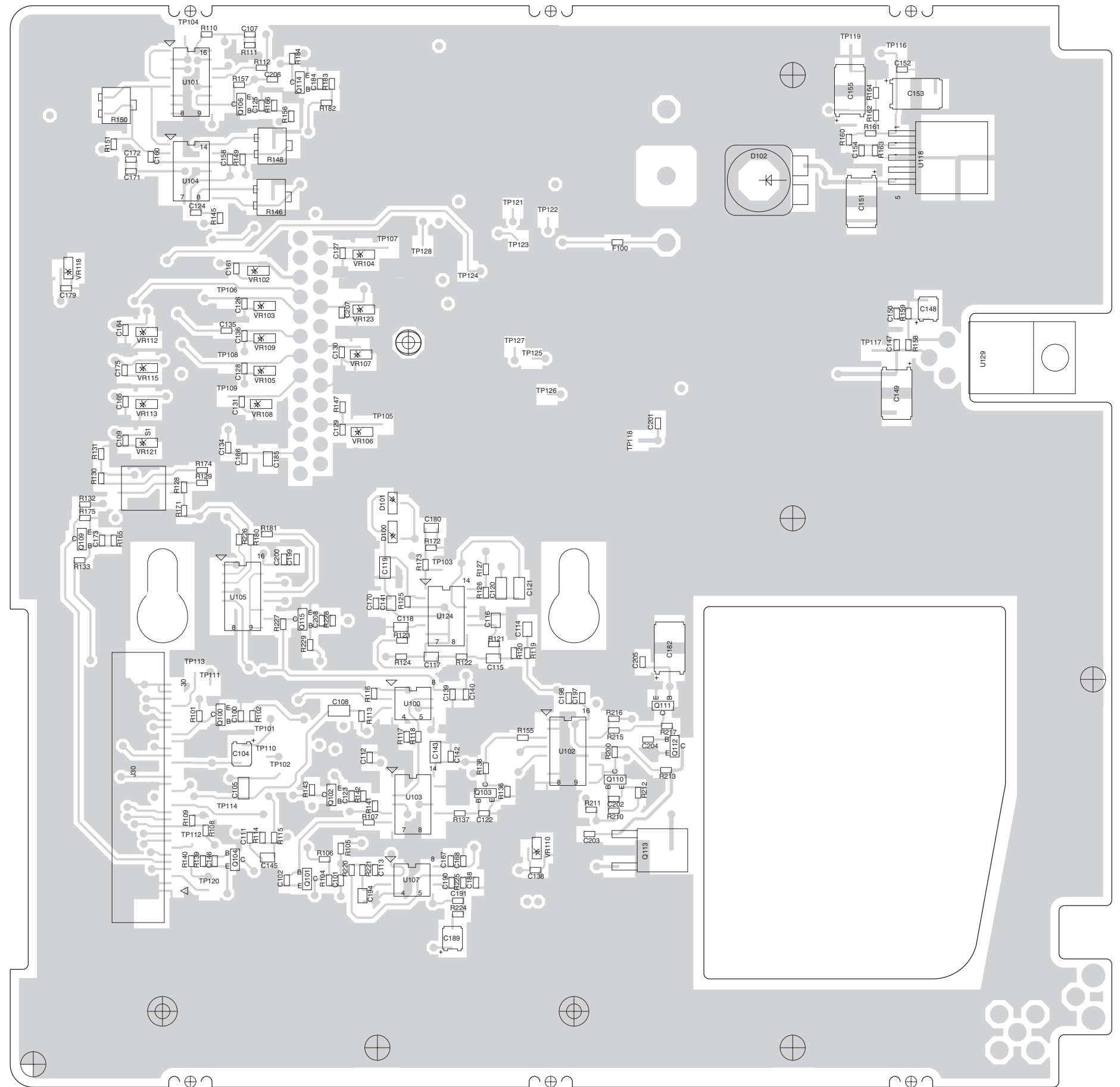

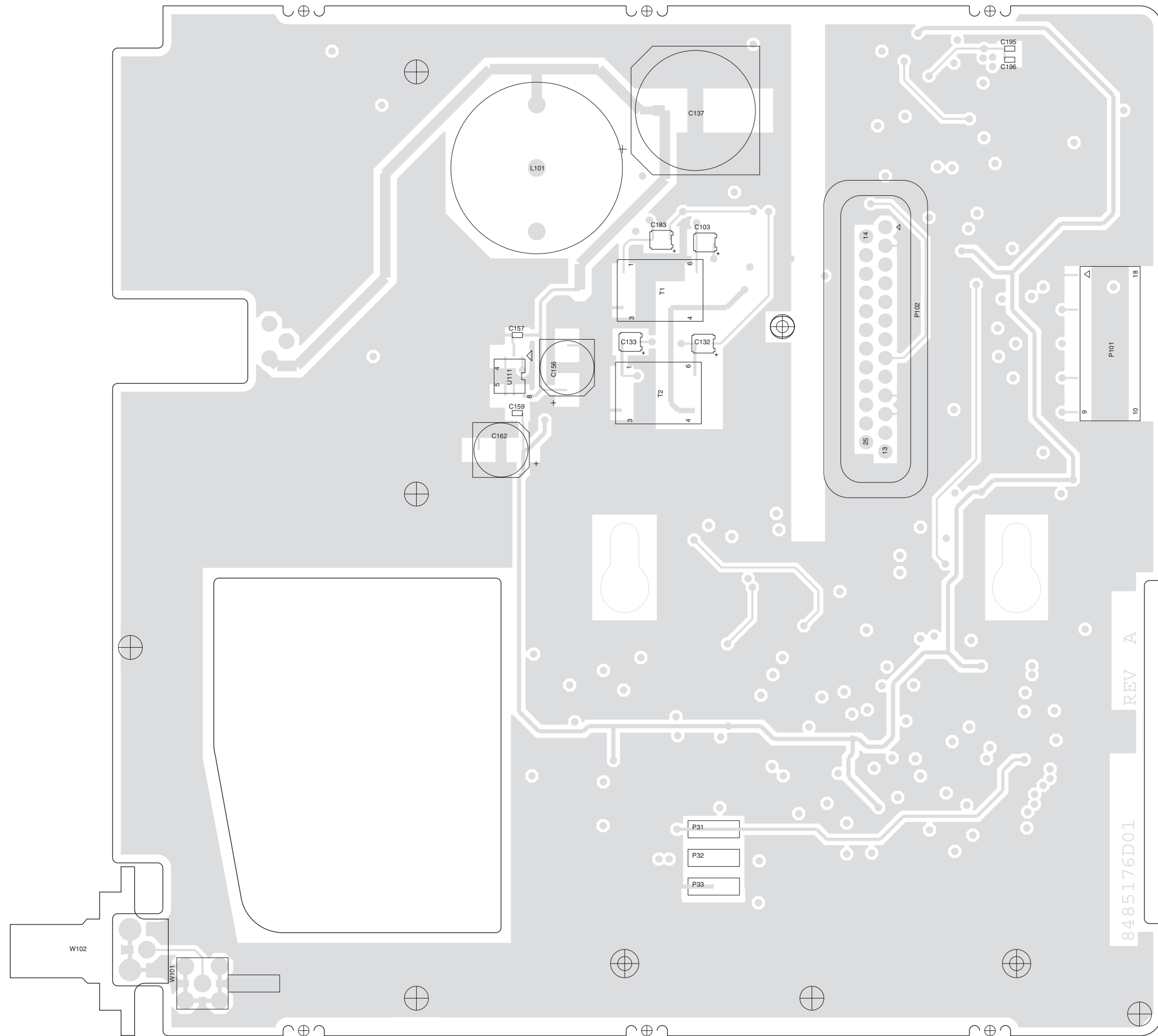

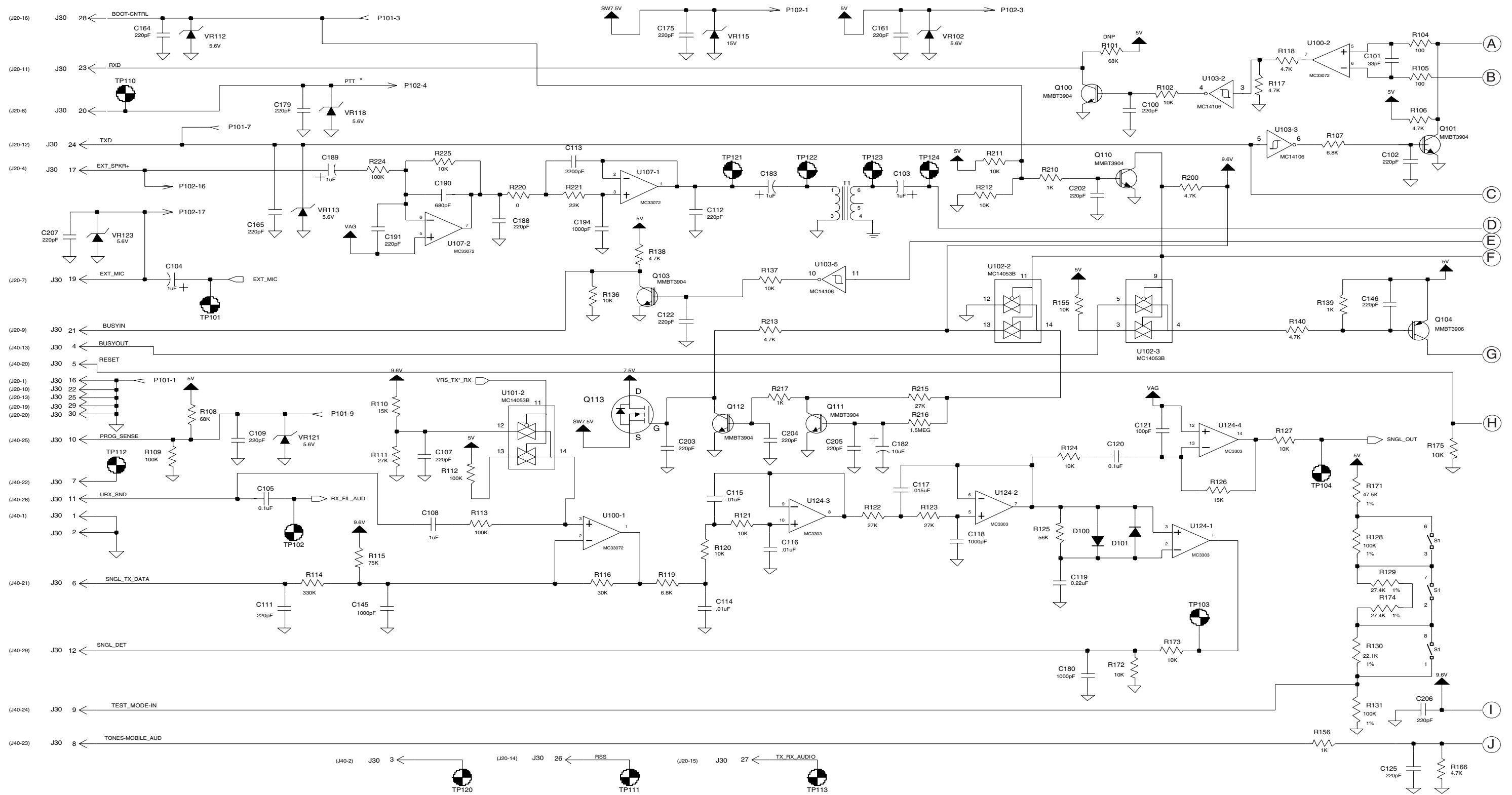

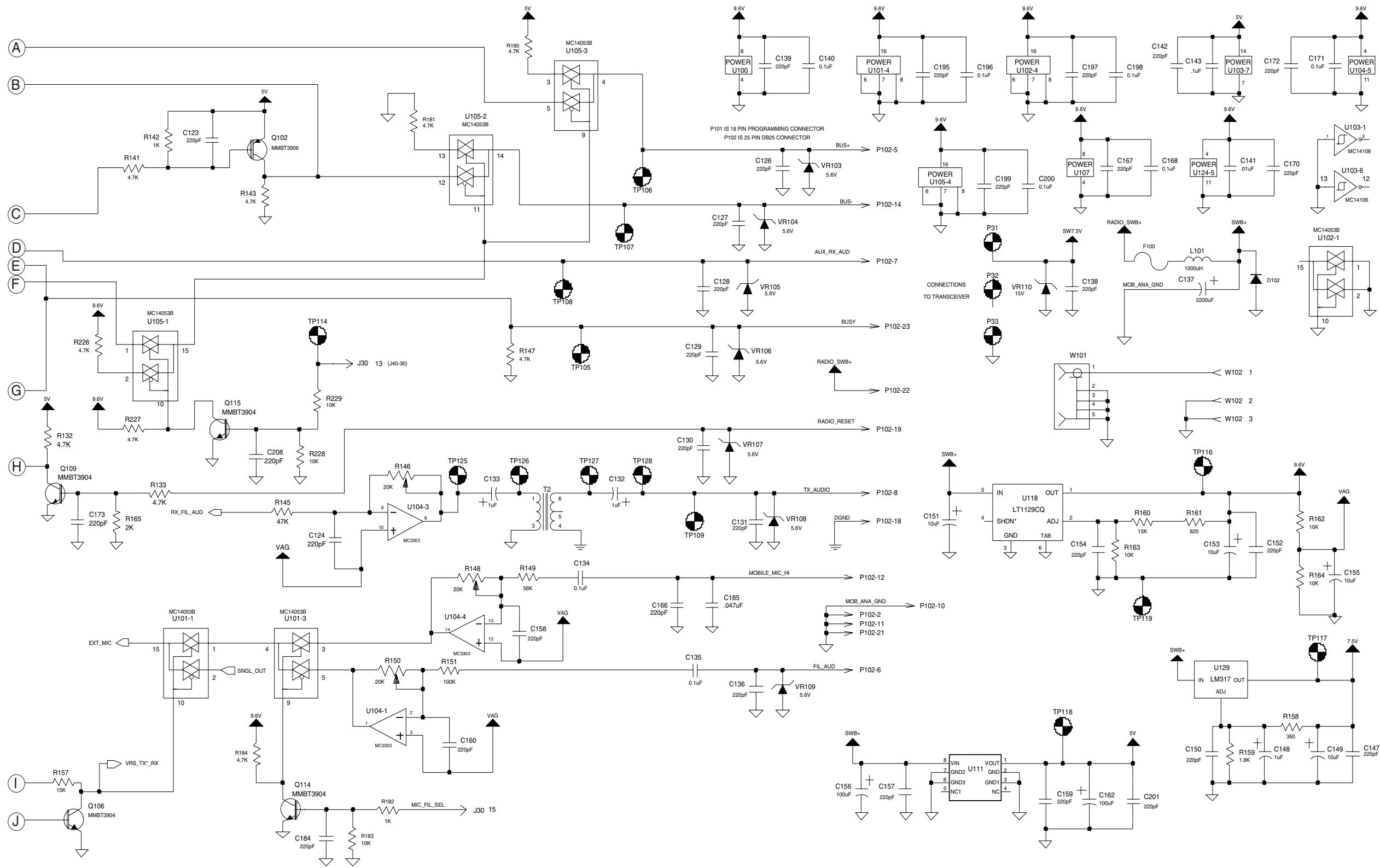

**VRS750 Vehicular Repeater System
Exploded View Parts List**

ITEM NO.	MOTOROLA PART NUMBER	DESCRIPTION
1	1505764X01	COVER ASSEMBLY, Midpwr Top
2	3205931V02	GASKET, Front Cover
3	1505905V02	HOUSING, Remote Front
4	2805347X01	CONNECTOR, 18 Position
5	4205395X01	RETAINER, Programming Connector
6	3205789X01	GASKET, Remote Cable
7	3385950D01	LABEL, Front
8	1505784W01	HOUSING, Programming Connector
9	1505791W01	HOUSING, Programming Connector Terminal
10	3285803D01	PLUG, Programming Connector
11	PLN7780A	VRS750 Controller Board
12	0310907A20	SCREW, M3 x .5 x 10 (8 req'd)
13	320545Z03	GASKET, Antenna Connector
14	0410057A13	WASHER, Nylon (for Regulator)
15	1483820M02	INSULATOR, Nylon, Heat Conductive (for Regulator)
16		TRANSCIVER
	PMLD4196A	VHF Transceiver
	PMLE4242A	UHF R1 Transceiver
	PMLE4243A	UHF R2 Transceiver
17	2885170D01	PLUG, RF Phone to SMB
18	3085166D01	CABLE, RF Coax
19	4285033D01	RETAINER, Internal Radio (2 req'd)
20	0300139800	SCREW, 6-32 x .5
21	0200844628	NUT, 6-32
22	4285168D01	RETAINER, Flex Connector
23	1485171D01	INSULATOR, PC Board
24	8485177D01	CABLE, Flex
25	2785032D01	CHASSIS, Modified
26	3205934V01	GASKET, Casting
27	4205938V01	CLIP, Spring
28	3885558D01	PLUG, Plastic DC
29	3285169D01	SEAL, Power
30	0785588D01	BRACKET, Sp. Mounting
31	3205935V01	GASKET, 25-Pin Connector
32	0305760W02	SCREW, M5 x 0.8 x 12 (2 req'd)
33	0400135783	WASHER, Lk. Spl't. (2 req'd)
34	0490440S01	WASHER, Flat (2 req'd)
35	0312002B14	SCREW, 10-16 x 1 (4 req'd)

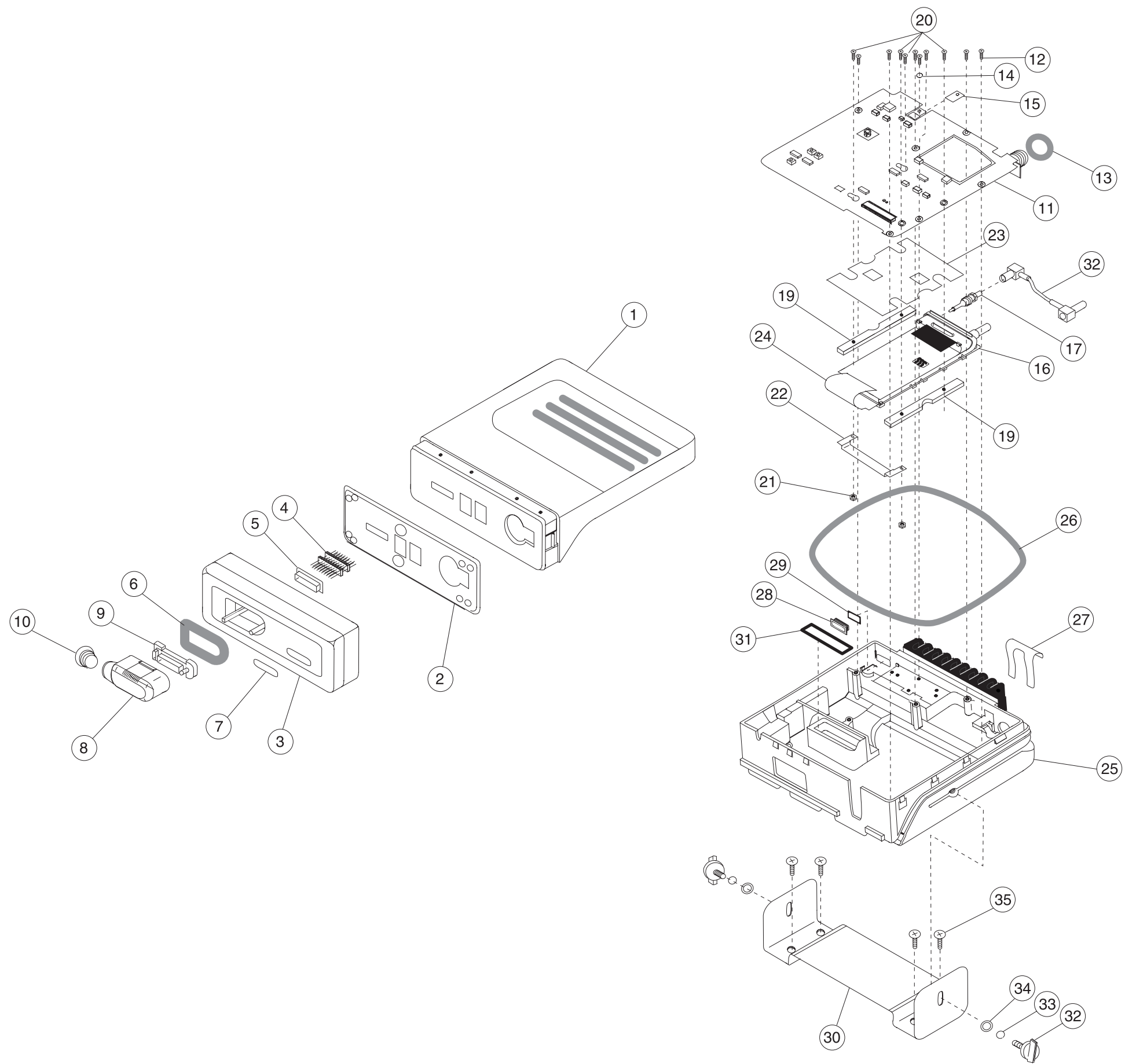

VRS-to-Mobile Cable HKN6153A

Pin Number		Signal Name
VRS750 P102	ASTRO Spectra Mobile DB25 Female	
1		N/C
2	2	FIL_Audio_GND
3		N/C
4		N/C
5	5	Bus+
6	6	FLT_Audio
7	7	Rx_Audio
8	8	Tx_Audio
9		N/C
10	10	AGND
11	11	Mic_Lo
12	12	Mic_Hi
13		N/C
14	14	Bus-
15		N/C
16		N/C
17		N/C
18	18	DGND
19	19	Reset
20		N/C
21	21	Bus_GND
22	22	SWB+
23	23	Busy
24		N/C
25		N/C

VRS-to-Siren Cable HKN6154A

Pin Number		Signal Name
VRS750 P102	Siren (HLN1439A) 39 pin J1	
1		N/C
2	15	FIL_Audio_GND
3		N/C
4		N/C
5	17	Bus+
6	9	FLT_Audio
7	33	Rx_Audio
8	3	Tx_Audio
9		N/C
10	11	AGND
11	14	Mic_Lo
12	27	Mic_Hi
13		N/C
14	25	Bus-
15		N/C
16		N/C
17		N/C
18	19	DGND
19	4	Reset
20		N/C
21	18	Bus_GND
22	6	SWB+
23	5	Busy
24		N/C
25		N/C

VRS750 Programming Cable 3085031D01

Pin Number		Signal Name
VRS750 P101	SRIB DB25 Female	
1	1	Ground
2		N/C
3	16	Boot_Cntl
4		N/C
5		N/C
6		N/C
7	15	TXD
8		N/C
9	2	Prog_Sense

Pin Number		Signal Name
VRS750 P101	SRIB DB25 Female	
10		N/C
11		N/C
12		N/C
13		N/C
14		N/C
15		N/C
16		N/C
17		N/C
18		N/C

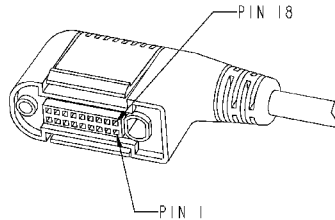
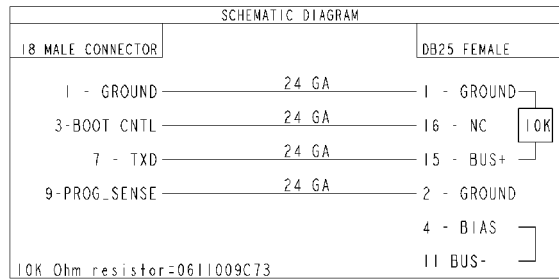

VRS750 Programming Cable Schematic (3085031D01)

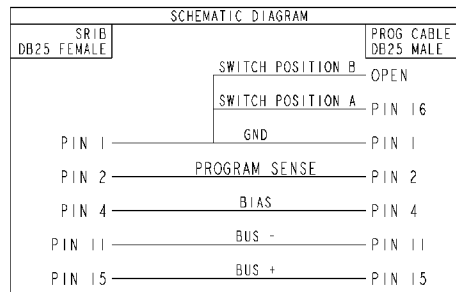

VRS750 Flashing Adapter Schematic (NTN4056A)

REPLACEMENT PARTS ORDERING

ORDERING INFORMATION

When ordering replacement parts or equipment information, the complete identification number should be included. This applies to all components, kits, and chassis. If the component part number is not known, the order should include the number of the chassis or kit of which it is a part, and sufficient description of the desired component to identify it.

Crystal and channel element orders should specify the crystal type or channel element type number, crystal and carrier frequency, and the model number in which the part is used.

MAIL ORDERS

Send written orders to the following addresses:

Replacement Parts/
Test Equipment/Manuals/
Crystal Service Items:

Motorola Inc.
United States and Canada
Accessories and Aftermarket
Division
Attention: Order Processing
1313 E. Algonquin Road
Schaumburg, IL 60196

Federal Government Orders:

Motorola Inc.
United States and Canada
Accessories and Aftermarket
Division
Attention: Order Processing
7230 Parkway Drive
Landover, MD 21076

International Orders:

Motorola Inc.
United States and Canada
Accessories and Aftermarket
Division
Attention: International Order
Processing
1313 E. Algonquin Road
Schaumburg, IL 60196

TELEPHONE ORDERS

United States and Canada Accessories and Aftermarket Division:
Call: 1-800-422-4210
1-800-826-1913 (For Federal Government Orders)
1-847-538-8023 (International Orders)

Servicers Training (VHS Video Tapes):
Call: 847-576-2828

FAX ORDERS

United States and Canada Accessories and Aftermarket Division:
FAX: 847-538-8198 (Domestic)
847-576-3023 (International)
Parts ID: 847-538-8194

Federal Government Orders:
FAX: 410-712-4991
International: 410-712-6200

PARTS CUSTOMER SERVICE

United States and Canada Accessories and
Aftermarket Division:
Call: 1-800-422-4210
Parts Identification:
Call: 847-538-0021

PRODUCT CUSTOMER SERVICE

Customer Resource Product Support
(Sales and Service Assistance):
Call: 1-800-927-2744
FAX: 1-954-723-4800



6881094C84

Motorola
8000 West Sunrise Boulevard
Fort Lauderdale, Florida 33322