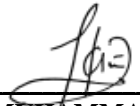

<p><b>MOTOROLA PENANG ADV. COMM. LABORATORY</b> Motorola Solutions Malaysia SDN BHD, Plot 2A, Medan Bayan Lepas, Mukim 12 S.W.D, 11900 Bayan Lepas, Penang, Malaysia.</p>	<p><b>FCC/ISED TEST REPORT</b> <b>Report Revision : Rev.B</b></p>
<p><b>Date/s Tested</b> : 07-AUG-2023 - 15-AUG-2023 <b>Report Issue Date</b> : 22-AUG-2023 <b>Manufacturer</b> : Motorola Solutions Malaysia SDN BHD <b>Manufacturer Address</b> : Plot 2A, Medan Bayan Lepas, Mukim 12 SWD, 11900 Bayan Lepas, Penang, Malaysia <b>Requestor</b> : HOMICIL HARLY <b>Product Type</b> : Hand-held <b>Product Version (PMN)</b> : APX N50, APX N30  <b>Model Number (HVIN)</b> : H25XDF9PW6AN, H15XDF9PW6AN <b>Frequency Band</b> : 380-520MHz <b>Max RF Output Power</b> : 5.7 Watts <b>Applicant Name</b> : Motorola Solutions Inc <b>Applicant Address</b> : 8000 West Sunrise Boulevard, Fort Lauderdale, Florida 33322  <b>ISED Registrations</b> : MY0001 <b>FCC Registrations</b> : 461337 <b>Firmware Version (FVIN)</b> : L06221125</p> <p><b>The equipment was tested accordance to the requirement listed below:</b></p> <p>(LMR ) FCC 47 CFR Part 2/ 22 / 74 / 80 / 90 ISED RSS- Gen Issue 5 / 119 Issue 12</p> <p style="text-align: right;"><b>PASS</b></p>	
<p>This report shall not be reproduced without written approval from an officially designated representative of the Motorola Penang Adv. Comm. Laboratory. The results and statements contained in this report pertain only to the device(s) evaluated.</p>	
<p>Prepared By:</p>  _____ <b>MUHAMMAD HAZIM</b> <b>Test Personnel</b>	<p>Approved Signatory:</p>  _____ <b>HO SZE KHIAN</b> <b>Responsible Engineer</b>

# Table of Contents

Report Revision History .....	3
1.0 General Information.....	4
2.0 Summary of Test Results .....	5
3.0 Measurement Uncertainty.....	6
4.0 Equipment List.....	7
5.0 Test Condition.....	10
5.1. Transmitter Test Conditions .....	10
6.0 Transmitter Test Parameters .....	11
6.1. RF Output Power .....	11
6.1.1. Test Setup .....	11
6.1.2. Test Result .....	11
6.2. Frequency Stability .....	12
6.2.1. Test Setup .....	12
6.2.2. Test Result .....	13
6.2.3. Test Limit.....	14
6.3. Modulation Characteristics .....	15
6.3.1. Test Setup .....	15
6.3.2. Test Result .....	16
6.3.3. Test Limit.....	18
6.4. Modulation Limiting.....	19
6.4.1. Test Setup .....	19
6.4.2. Test Result .....	20
6.4.3. Test Limit.....	21
6.5. Occupied Bandwidth.....	22
6.5.1. Test Setup (Analog).....	22
6.5.2. Test Result (Analog).....	23
6.5.3. Test Setup (Digital).....	31
6.5.4. Test Result (Digital).....	32
6.5.5. Test Limit.....	42
6.6. Band Edge Conducted Spurious Emission (Part 22) .....	43
6.6.1. Test Setup (Analog).....	43
6.6.2. Test Result (Analog).....	44
6.6.3. Test Setup (Digital).....	45
6.6.4. Test Result (Digital).....	46
6.6.5. Test Limit.....	47
6.7. Transient Frequency Behavior .....	48
6.7.1. Test Setup .....	48
6.7.2. Test Result .....	49
6.7.3. Test Limit.....	51
6.8. Adjacent Channel Power.....	52
6.8.1. Test Setup (Analog).....	52
6.8.2. Test Result .....	52
6.8.3. Test Setup (Digital).....	53

6.8.4. Test Result ..... 53  
 6.8.5. Test Limit..... 54  
 6.9. Conducted Spurious Emission ..... 56  
     6.9.1. Test Setup ..... 56  
     6.9.2. Test Result (Analog)..... 57  
     6.9.3. Test Result (Digital)..... 68  
     6.9.4. Test Limit..... 88  
 6.10. Radiated Spurious Emission ..... 89  
     6.10.1. Test Setup ..... 89  
     6.10.2. Test Result (Analog)..... 90  
     6.10.3. Test Result (Digital)..... 112  
     6.10.4. Test Limit..... 132  
 6.11. Effective Radiated Power (ERP) ..... 133  
     6.11.1. Test Setup ..... 133  
     6.11.2. Test Result ..... 134  
     6.11.3. Test Limit..... 134  
 6.12. GNSS (EIRP for 1559 - 1610MHz)..... 135  
     6.12.1. Test Setup ..... 135  
     6.12.1. Test Result ..... 135  
     6.12.2. Test Limit..... 135

**Report Revision History**

<b>Revision History</b>	<b>Description</b>	<b>Date</b>	<b>Originator</b>
Rev. A	Initial Report	09-Oct-23	Hazim
Rev. B	Update Firmware Version (FVIN), remove Part 24 and RSS 182	06-Nov-23	Hazim

## 1.0 General Information

### EUT Description:

<b>Technologies</b>	Land Mobile Radio (LMR)
<b>Modulation Type</b>	FM, C4FM, PHASE II

The EUT contains following accessory devices and data cable:

Item	Brand	Model or P/N
BATT LIION IMPRES 2 IP68 2850T	MOTOROLA	PMNN4813A
PROGRAMMING, TEST & ALIGNMENT CABLE	MOTOROLA	PMKN4231A
UHF Whip Antenna (380 - 520 MHz) 380-520 MHz	MOTOROLA	AN000452A01

### General Description of Applied Standards

The EUT is a RF Product. According to the specifications of the manufacturer, the EUT is to comply with the requirements of the following standards:

#### ANSI C63.26-2015

No modifications were done to the UUT to facilitate the tests in this report.

### Deviation from standard

Not applicable as no deviation from standard test method

### Antenna gain disclaimer

Antenna gain information is provided by customer. The validity of the results is dependent upon this information. The lab will not be held accountable in the event the supplied information affects compliance.

### Test configuration of EUT

All relevant configurations involving radio models and accessories (including chargers, batteries, and antennas) were assessed. Only worst case configurations will be included in this report.

## 2.0 Summary of Test Results

FCC General Rules Part (47CFR)	ISED General Rules Part	Test Item	Result	Remarks	Serial number tested
2.1046(a), 22.565(f), 74.461, 80.215	RSS-119	RF Power Output	Pass		287TZP0071
2.1055, 22.355, 74.464, 80.209	RSS-119	Frequency Stability	Pass		287TZP0071
2.1047	-	Audio Frequency Response	Pass		287TZP0071
2.1047	-	Audio Low Pass Filter Response	NA		
2.1047, 74.463, 80.213	-	Modulation limiting	Pass		287TZP0071
2.1049, 22.359, 90.21, 74.462, 80.211(b), (c)	RSS-119	Occupied Bandwidth	Pass	16K0F3E: 15.0153kHz 11K0F3E: 9.9702 kHz 8K10F1D/FXD: 7.8920 kHz 8K10F1E /FXE: 7.8123 kHz 8K10F1W: 7.8762 kHz 20K0F1E: 10.3929 kHz	287TZP0071
2.1051, 22.359 (a), (b)	-	Band Edge Conducted Spurious Emission	Pass		287TZP0071
90.214	RSS-119	Transient Frequency Behavior	Pass		287TZP0071
90.543(a), (b)	RSS-119	Adjacent Channel Power	NA		
2.1051, 22.359, 90.210 74.462(c), 80.211(f)	RSS-119	Conducted Spurious Emissions	Pass	Worst case: -39.67 dBm	287TZP0071
2.1051, 22.359, 74.462(c), 80.211(f)	RSS-119	Radiated Spurious Emission	Pass	Worst case: -46.4909 dBm (margin: 26.4909 dB, Noise Floor)	287TZP0060
-	-	GNSS (EIRP for 1559 – 1610MHz)	NA		
-	-	Effective Radiated Power (ERP)	Pass		287TZP0060

NA → Not Applicable

### 3.0 Measurement Uncertainty

Measurement	Frequency	Expanded Uncertainty (k=1.96) (±)
AC Power Line Conducted Spurious Emission	150KHz ~ 30MHz	3.48 dB
Radiated Emissions up to 1 GHz dB $\mu$ V/m (Field Strength)	30MHz ~ 1000MHz	5.88 dB
Radiated Emissions above 1 GHz dB $\mu$ V/m (Field Strength)	1GHz ~ 18GHz	5.84 dB
	18GHz ~ 40GHz	6.02 dB
Radiated Emissions dBm (ERP/EiRP)	30MHz ~ 18GHz	4.03 dB
Conducted Spurious Emissions	9kHz ~ 12.75GHz	2.82 dB
Frequency Stability	9kHz ~ 12.75GHz	0.0085 ppm
Audio Frequency Response / Low Pass Filter Response	300Hz – 20kHz	4.09 %
Modulation Limiting	300Hz – 3kHz	1.15 %
Occupied Bandwidth	9kHz ~ 12.75GHz	2.82 dB
Band Edge Conducted Spurious Emission	9kHz ~ 12.75GHz	2.82 dB
Transient Frequency Behavior	9kHz ~ 12.75GHz	5.4 ms
Adjacent Channel Power	9kHz ~ 12.75GHz	2.82 dB

#### 4.0 Equipment List

##### FCC Analog ATE#1: (SW version: FCC\_Analog\_v2.5.0)

Description	Model	Serial Number	Calibration Date	Calibration Due Date
CHAMBER	SH-641	92009188	09-Mar-23	09-Mar-24
POWER METER	E4416A	MY50000115	10-Feb-23	10-Feb-24
AUDIO ANALYZER	U8903B	MY62380007	04-Nov-22	04-Nov-23
POWER SENSOR	E4412A	MY49000115	08-Oct-22	08-Oct-23
POWER SUPPLY	6032A	3232A08410	20-Jun-23	20-Jun-24
CXA SIGNAL ANALYZER	N9000B	MY60251574	20-May-23	20-May-24
POWER SUPPLY	6023A	3236A05513	13-Jun-23	13-Jun-24
N to N RF Cable # 1	M17/128-RG400	NA	NA	NA
BNC to N RF Cable # 1	RG 58	NA	NA	NA
BNC to BNC RF Cable # 1	RG 58	NA	NA	NA
BNC to BNC RF Cable # 2	RG 58	NA	NA	NA
BNC to BNC RF Cable # 3	RG 58	NA	NA	NA
BNC to BNC RF Cable # 4	RG 58	NA	NA	NA
BNC to BNC RF Cable # 5	RG 58	NA	NA	NA
BNC to BNC RF Cable # 6	RG 58	NA	NA	NA
BNC to BNC RF Cable # 7	RG 58	NA	NA	NA
N to SMA RF Cable # 1	RG 58	NA	NA	NA
N to SMA RF Cable # 2	RG 58	NA	NA	NA
N to SMA RF Cable # 3	RG 58	NA	NA	NA
Aeroflex Attenuator 30dB	49-30-34-LIM	NA	NA	NA

**FCC Transient ATE #1: (SW version: FCC Transient ATE\_R1.2.1)**

Description	Model	Serial Number	Calibration Date	Calibration Due Date
SWITCH CONTROL UNIT	3488A	2719A36210	CNR	CNR
ATTENUATOR / SWITCH DRIVER	11713A	3748A09090	CNR	CNR
POWER SENSOR	E9301B	MY50180003	20-Jun-23	20-Jun-24
SIGNAL GENERATOR	8657B	3315U04973	21-Sep-22	21-Sep-23
AUDIO ANALYZER	8903B	2836A05866	10-Nov-22	10-Nov-23
POWER METER	E4416A	MY45101016	01-Mar-23	01-Mar-24
STEP ATTENUATOR	8494G	MY52301411	16-Dec-22	16-Dec-23
POWER SUPPLY	6033A	3506A08076	10-Jan-23	10-Jan-24
ANALYZER SPECTRUM	E4445A	MY46181262	09-Jan-23	09-Jan-24
ATTENUATOR/110DB	8496G	MY52300757	20-Jun-23	20-Jun-24
AUDIO ANALYZER	8903B	3011A08952	12-Sep-22	12-Sep-23
ANALYZER MODULATION	8901B	2619A00845	20-Sep-22	20-Sep-23
OSCILLOSCOPE	M508064A	MY45003003	01-Nov-22	01-Nov-23
N to N RF Cable # 1	SF126/11N/11N	NA	NA	NA
N to N RF Cable # 1	SF126/11N/11N	NA	NA	NA
N to N RF Cable # 2	M17/128-RG400	NA	NA	NA
N to N RF Cable # 3	M17/128-RG400	NA	NA	NA
N to N RF Cable # 4	M17/128-RG400	NA	NA	NA
N to N RF Cable # 5	M17/128-RG400	NA	NA	NA
N to N RF Cable # 6	M17/128-RG400	NA	NA	NA
N to N RF Cable # 7	M17/128-RG400	NA	NA	NA
N to N RF Cable # 8	M17/128-RG400	NA	NA	NA
N to N RF Cable # 9	M17/128-RG400	NA	NA	NA
BNC to BNC RF Cable # 1	RG 58	NA	NA	NA
BNC to BNC RF Cable # 2	RG 58	NA	NA	NA
BNC to BNC RF Cable # 3	RG 58	NA	NA	NA
BNC to BNC RF Cable # 4	RG 58	NA	NA	NA
BNC to BNC RF Cable # 5	RG 58	NA	NA	NA
BNC to BNC RF Cable # 6	RG 58	NA	NA	NA
BNC to N RF Cable # 1	RG 58	NA	NA	NA
Aeroflex Attenuator 10dB	49-10-43-LIM	NA	NA	NA
Aeroflex Attenuator 10dB	33-10-34-LIM	NA	NA	NA



**FCC CONDUCTED SPUR EMISSION ATE # 1 (SW version: Conducted Spur ATE\_rev 1.23.04)**

Description	Model	Serial Number	Calibration Date	Calibration Due Date
SWITCH CONTROL UNIT	3488A	2719A32735	CNR	CNR
POWER SUPPLY	6032A	US38323921	08-Dec-22	08-Dec-23
SPECTRUM ANALYZER	E4445A	MY46181250	20-May-23	20-May-24
INTERFACE BOX - FILTER	CNR	CS001	CNR	CNR
N to N RF Cable # 1	SF126/11N/11N	NA	NA	NA
N to N RF Cable # 2	SF126/11N/11N	NA	NA	NA
BNC to BNC RF Cable # 1	RG 58	NA	NA	NA
Aeroflex Attenuator 30dB	49-30-43-LIM	NA	NA	NA
Aeroflex Attenuator 10dB	33-10-34-LIM	NA	NA	NA

**EMC Chamber 1**

DESCRIPTION	MODEL	SERIAL NUMBER	CALIBRATION DATE	CALIBRATION DUE DATE
DRG HORN FREQ.	SAS-571	1143	08-Mar-23	08-Mar-25
DRG HORN FREQ.	SAS-571	720	18-Apr-23	18-Apr-25
DC Power Supply	6033A	3211A06649	12-Jun-22	12-Jun-24
SIGNAL GENERATOR	SMB 100A	182511	4-Jun-21	4-Jun-24
EMI TEST RECEIVER	ESW44	101750	24-Sept-22	24-Sept-23
5m SEMI-ANECHOIC CHAMBER	S800-HX	J2308	No Cal. Req'd	No Cal. Req'd
BILOG ANTENNA	CBL6112D	30991	5-Jan-23	5-Jan-24
BILOG ANTENNA	CBL6112D	55546	23-Jun-22	23-Sep-23
DATA LOGGER THERMOHYGROMETER	SDL500	A.016800	21-Jun-23	21-Jun-24
SYSTEM CONTROLLER	SC104V	050806-1	No Cal. Req'd	No Cal. Req'd
TURNTABLE FLUSH MOUNT 2M	FM2011	NA	No Cal. Req'd	No Cal. Req'd
ANTENNA POSITIONING TOWER	TLT2	NA	No Cal. Req'd	No Cal. Req'd
BROAD-BAND HORN ANTENNA	BBHA9170	BBHA9170143	18-Aug-22	18-Aug-23
PREAMPLIFIER 18-40GHz	Miteq Hi Gain Sucoflex	002	No Cal. Req'd	No Cal. Req'd
PREAMPLIFIER	PAM-0118P	361	11-Sep-20	11-Sep-23
LOOP ANTENNA	6502	00208416	12-Oct-22	12-Oct-23
TEST SOFTWARE	EMC_FCC_IC_BLUETOOTH_RE_TEST			
VERSION	EMC_FCC_RE_v1.6.5			

## 5.0 Test Condition

### 5.1. Transmitter Test Conditions

Test Item, (Channel Spacing)	Power (W)	Modulation	Test Frequency (MHz)	Tested By	Environmental conditions
RF Output Power	Low & Max	FM	380.0125, 406.2, 450.025, 459.125, 467.775, 469.9875, 482.0125, 511.9875 519.9875	Hazim	23.4°C, 50%RH
Frequency Stability	Max	FM	467.775	Hazim	25.1°C, 54.3%RH, 60.3°C, 50%RH, -30.1°C, 51.2%RH
Audio Frequency Response (12.5kHz / 25kHz)	Max	FM	459.125, 467.775	Hazim	23.4°C, 50%RH
Audio Low Pass Filter Response (12.5kHz / 25kHz)	Max	FM	459.125, 467.775		
Modulation limiting (12.5kHz / 25kHz)	Max	FM	459.125, 467.775	Hazim	23.4°C, 50%RH
Occupied Bandwidth (12.5kHz / 20kHz / 25kHz)	Max	FM/C4FM/ Phase II	406.2, 450.025, 459.125, 467.775, 473.0125, 511.9875	Hazim	23.4°C, 50%RH
Band Edge Conducted Spurious Emissions (Part 22) (12.5kHz / 20kHz / 25kHz)	Max	FM//C4FM /Phase II	459.025, 459.65, 473.0125, 479.2875	Hazim	23.4°C, 50%RH
Transient Frequency Behavior (UHF & VHF Band) (12.5kHz / 25kHz)	Max	FM/C4FM	467.775	Hazim	23.4°C, 50%RH
Adjacent Channel Power (700MHz Band) (12.5kHz / 25kHz)	Max	FM/C4FM/ Phase II	NA		
Conducted Spurious Emissions- (12.5kHz / 25kHz)	Low / Max	FM/C4FM/ Phase II	380.0125, 406.2, 450.025, 459.125, 467.775, 482.0125, 511.9875, 519.9875	Hazim	23.4°C, 50%RH
Radiated Spurious Emission (12.5kHz / 25kHz)	Low / Max	FM/C4FM/ Phase II	380.0125, 406.2, 450.025, 459.125, 467.775, 482.0125, 511.9875, 519.9875	Nazrin & Rezza	23.4°C, 69.6%RH
GNSS (EIRP for 1559 - 1610MHz) (12.5kHz / 25kHz)	Max	FM	NA		
Effective Radiated Power (ERP) (12.5kHz / 25kHz)	Max	FM	467.775	Nazrin & Rezza	23.4°C, 69.6%RH

NA → Not Applicable

## 6.0 Transmitter Test Parameters

### 6.1 RF Output Power

#### 6.1.1 Test Setup

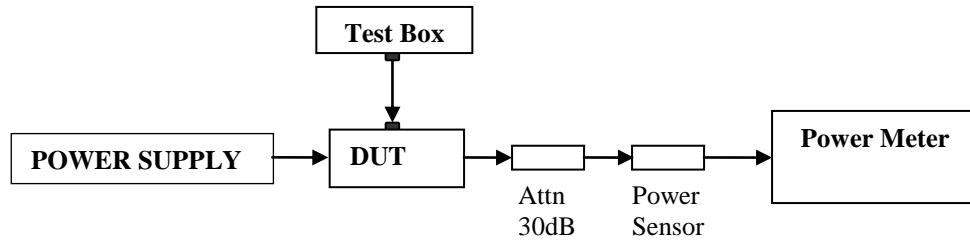

- 1) The DUT transmitter connected to Power Meter using the 30 dB attenuator and power sensor with above setup.
- 2) Path loss for the measurement included.
- 3) All the measurement was done at low, mid, high frequency for each band.
- 4) Record the power into the test report.

#### 6.1.2 Test Result

Temperature	25°C				
Voltage (V)	7.5V				
Frequency (MHz)	Low Power (W)	Current (A)	Max Power (W)	Current (A)	Remark
380.01250	1.00	1.03	5.61	2.19	Part 80
406.20000	1.00	0.99	5.61	2.15	
450.02500	1.00	0.99	5.70	1.94	
459.12500	1.00	0.89	5.70	1.98	
467.77500	1.00	0.91	5.70	2.03	
467.77500	1.00	0.84	2.00	1.08	
469.98750	1.00	0.91	5.70	2.03	
482.01250	1.00	0.90	5.59	2.11	
511.98750	1.00	1.08	5.60	2.29	
519.98750	1.00	1.15	5.63	2.43	

## 6.2. Frequency Stability

### 6.2.1. Test Setup

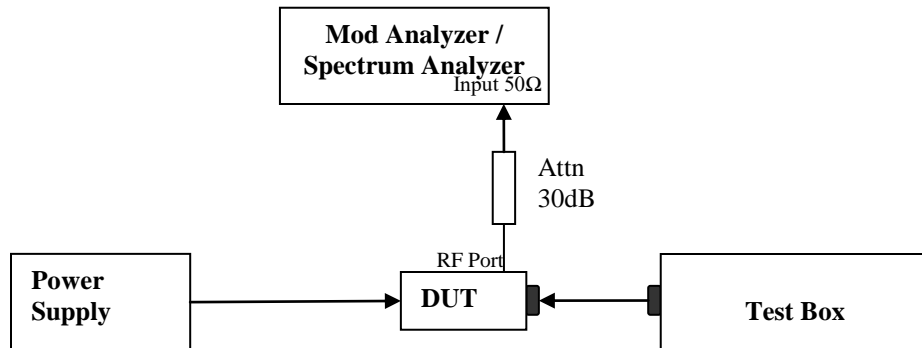

- 1) The DUT transmitter output port was connected to Modulation / Spectrum Analyzer.
- 2) Path loss for the measurement included.
- 3) Transmit the DUT and record the freq in  $MCF_{MHz}$ .
- 4) Test in 2 conditions:
  - Temperature: The frequency of the transmitter was measured from  $-30^{\circ}C$  to  $50^{\circ}C$ .
  - Supply Voltage:
    - Mobile: The frequency of the transmitter was measured from 85% to 115% of the nominal operating input voltage.
    - Portable: The frequency of the transmitter was measured from nominal  $\pm x\%$  as specified by the manufacturer
- 5) Calculate the ppm frequency error by the following:

$$ppm\ error = \left( \frac{MCF_{MHz}}{ACF_{MHz}} - 1 \right) * 10^6$$

Where:  $MCF_{MHz}$  is the Measured Carrier Frequency in MHz  
 $ACF_{MHz}$  is the Assigned Carrier Frequency in MHz

**6.2.2. Test Result**

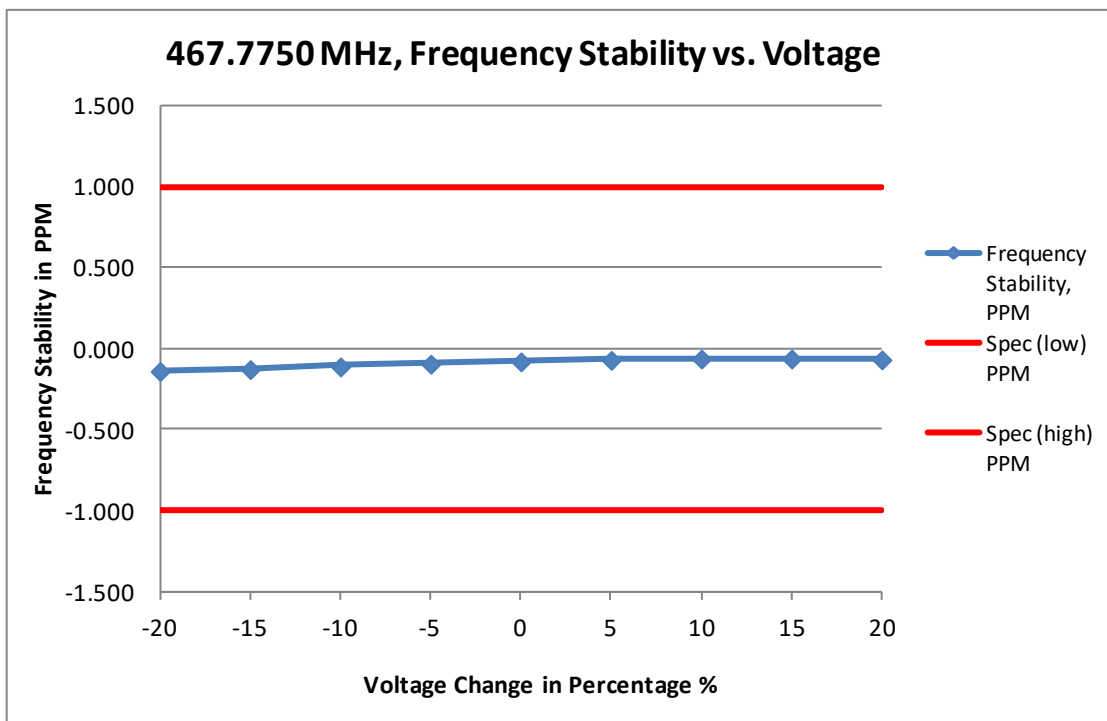

(i) Frequency Stability VS Voltage

Frequency / Channel Spacing	467.7750 MHz / 12.5 kHz				
Temperature, °C	25				
Voltage %	Voltage, V	Frequency, MHz	Frequency Stability, PPM	Spec (low) PPM	Spec (high) PPM
-20	6.000	467.774937	-0.135	-1.000	1.000
-15	6.375	467.774943	-0.123	-1.000	1.000
-10	6.750	467.774950	-0.106	-1.000	1.000
-5	7.125	467.774958	-0.090	-1.000	1.000
0	7.500	467.774965	-0.075	-1.000	1.000
5	7.875	467.774969	-0.066	-1.000	1.000
10	8.250	467.774973	-0.058	-1.000	1.000
15	8.625	467.774973	-0.058	-1.000	1.000
20	9.000	467.774971	-0.063	-1.000	1.000

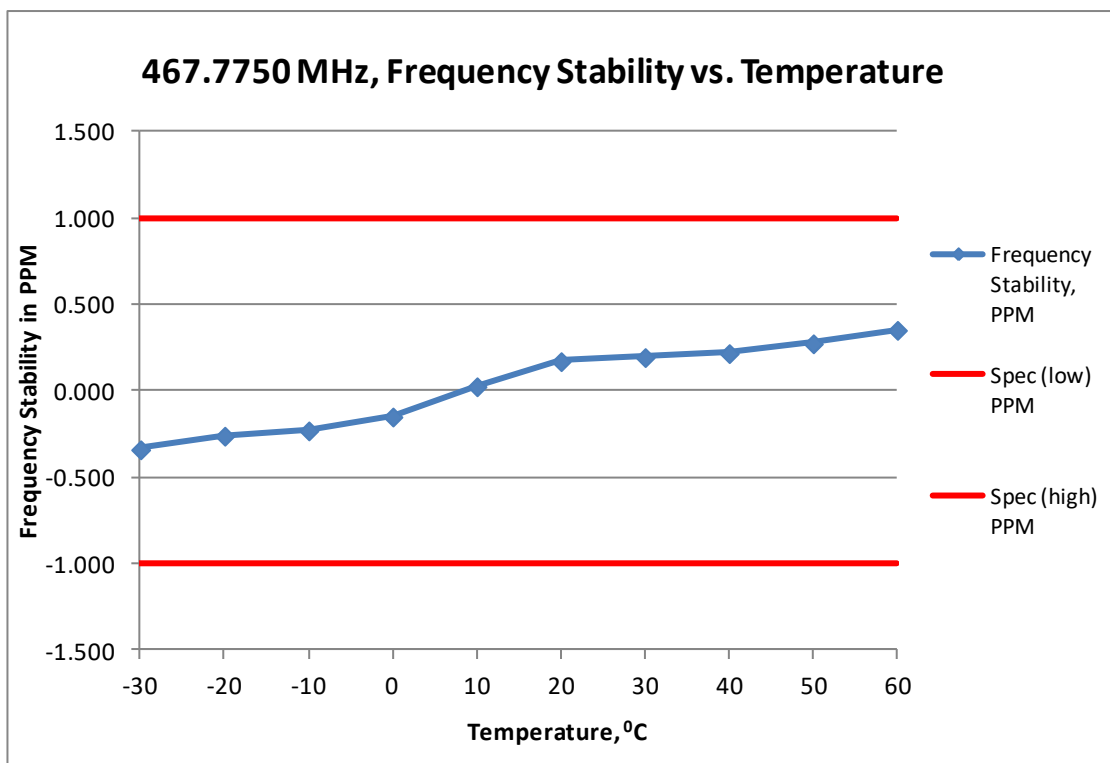

(ii) Frequency Stability VS temperature

Frequency / Channel Spacing	467.7750 MHz / 12.5 kHz			
Voltage, V	7.5			
Temperature, °C	Frequency, MHz	Frequency Stability, PPM	Spec (low) PPM	Spec (high) PPM
-30	467.774843	-0.336	-1.000	1.000
-20	467.774880	-0.257	-1.000	1.000
-10	467.774894	-0.226	-1.000	1.000
0	467.774932	-0.146	-1.000	1.000
10	467.775014	0.029	-1.000	1.000
20	467.775082	0.175	-1.000	1.000
30	467.775093	0.198	-1.000	1.000
40	467.775104	0.221	-1.000	1.000
50	467.775130	0.278	-1.000	1.000
60	467.775167	0.356	-1.000	1.000

**6.2.3. Test Limit**

As per manufacturer declared spec +/- 1.0ppm

### 6.3. Modulation Characteristics

#### 6.3.1. Test Setup

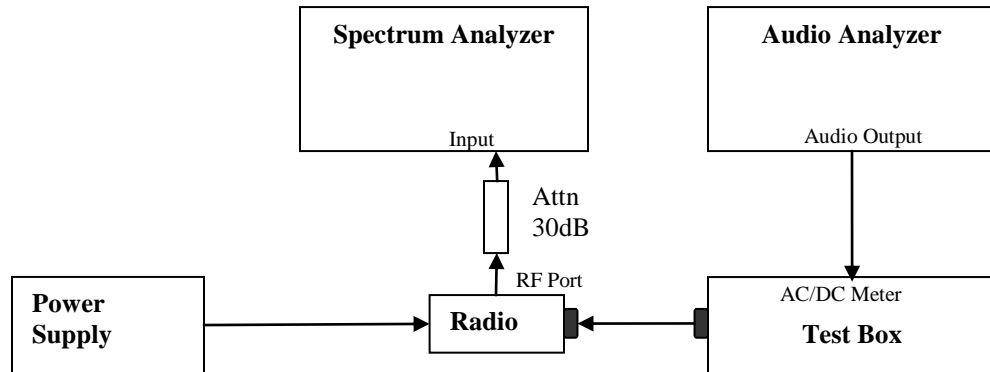

- 1) The DUT transmitter output port was connected to Modulation Analyzer.
- 2) Path loss for the measurement included.
- 3) Set the audio bandwidth filter to 15 kHz and 50 kHz.
- 4) Transmit the radio and set the audio analyzer to 1 kHz audio frequency and 20% of the Full rated system deviation.
- 5) On audio analyzer, set the rated level as 0dB reference
- 6) Vary the audio frequency from 300 Hz to 20 kHz. Record the change in modulation in reference to step 5.

### 6.3.2. Test Result

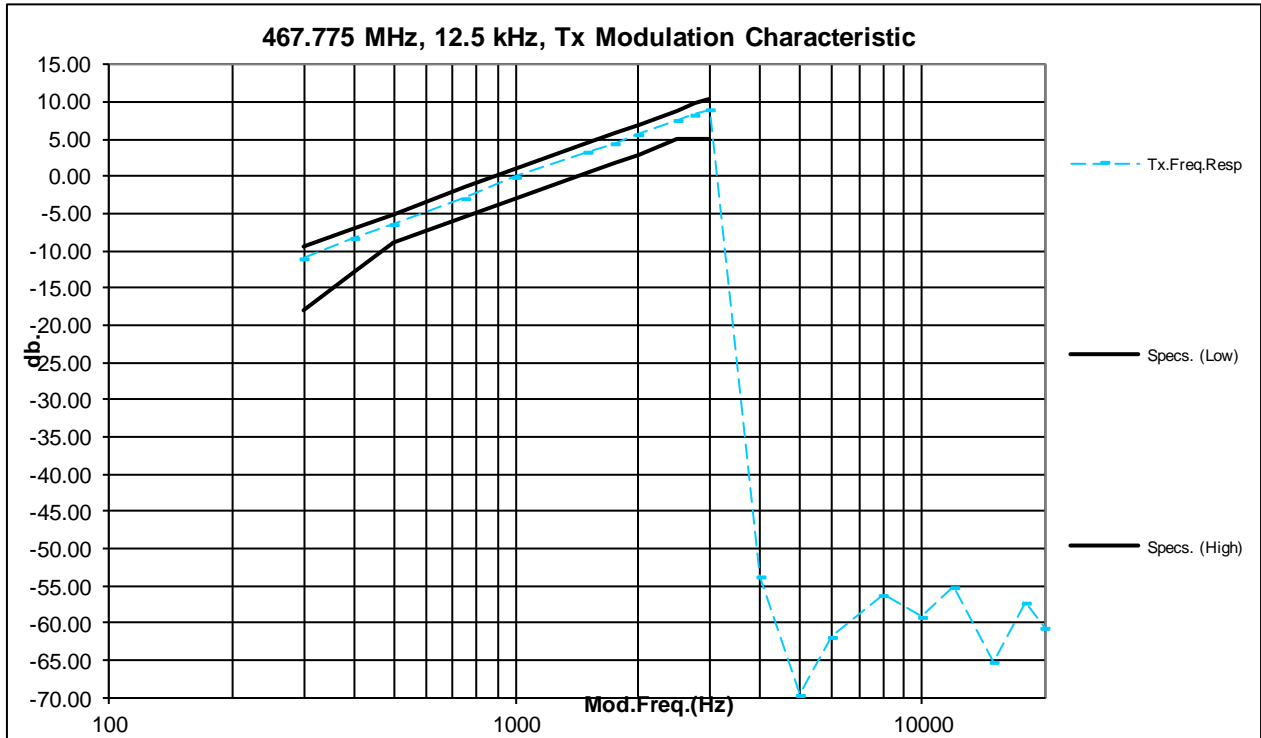

Not for FCC review

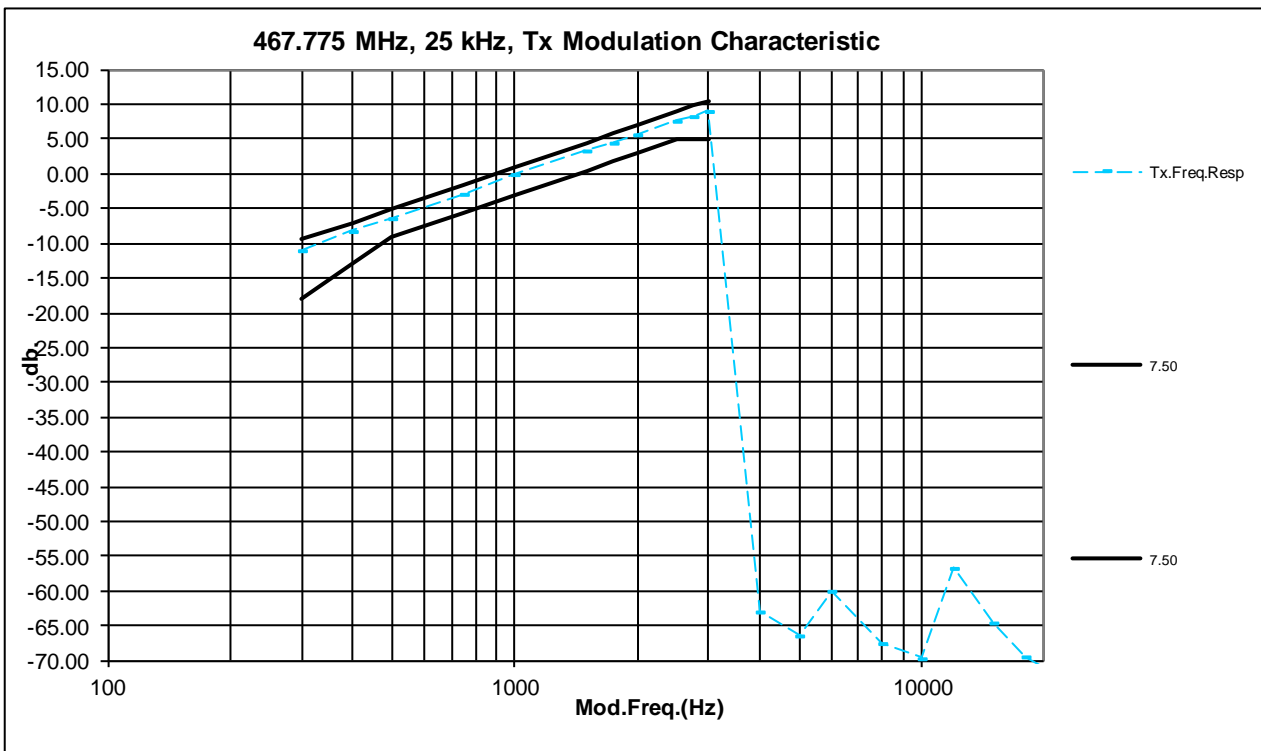



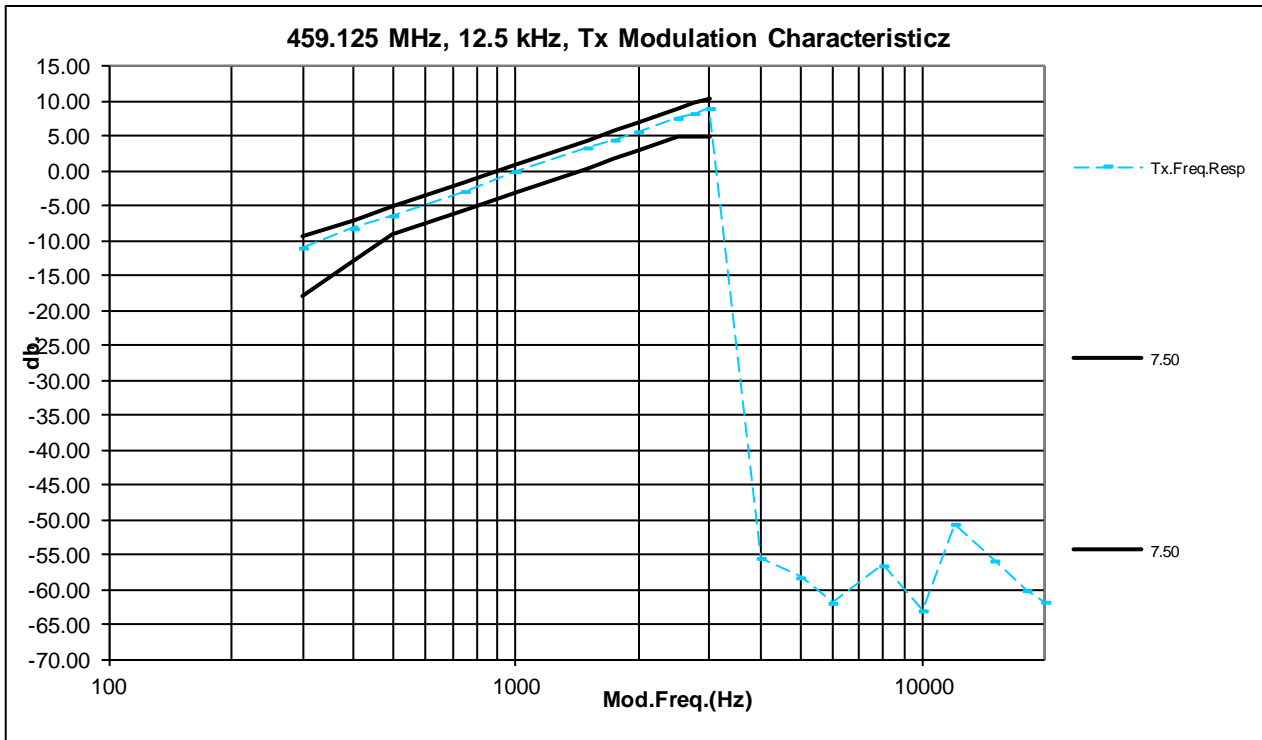

Not for FCC review

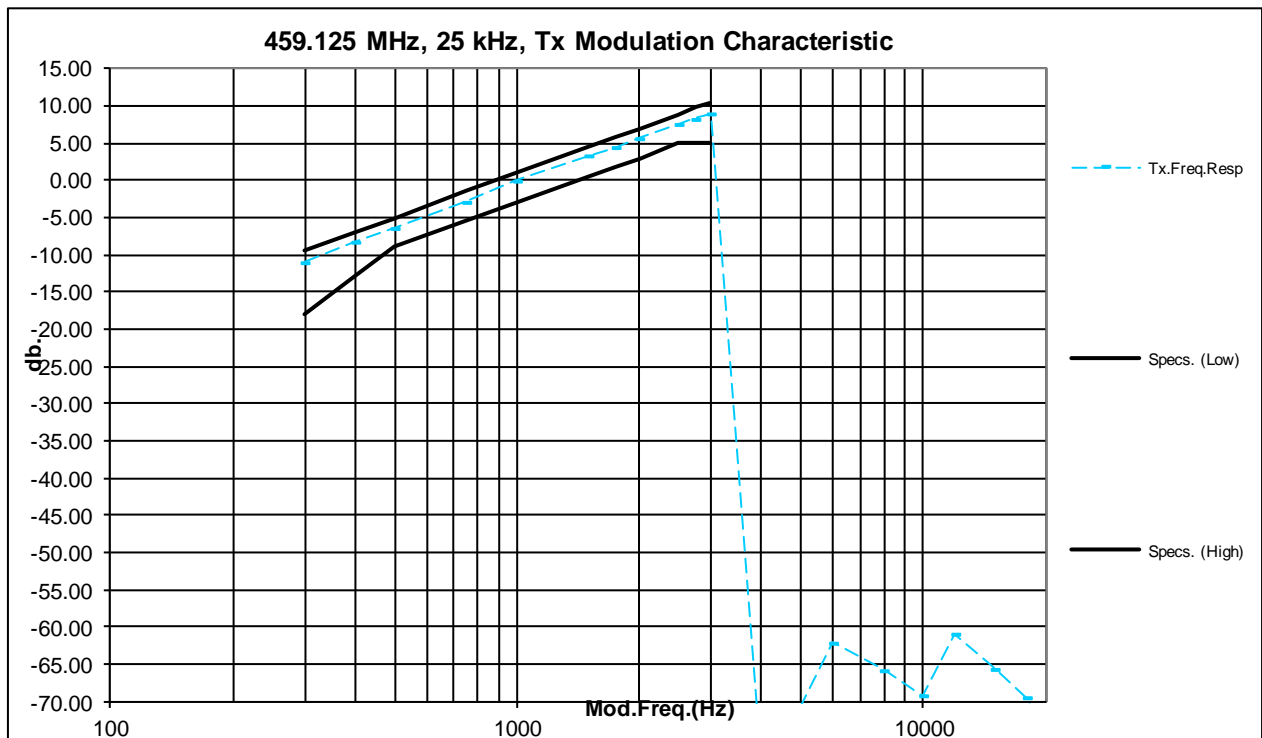

### 6.3.3. Test Limit

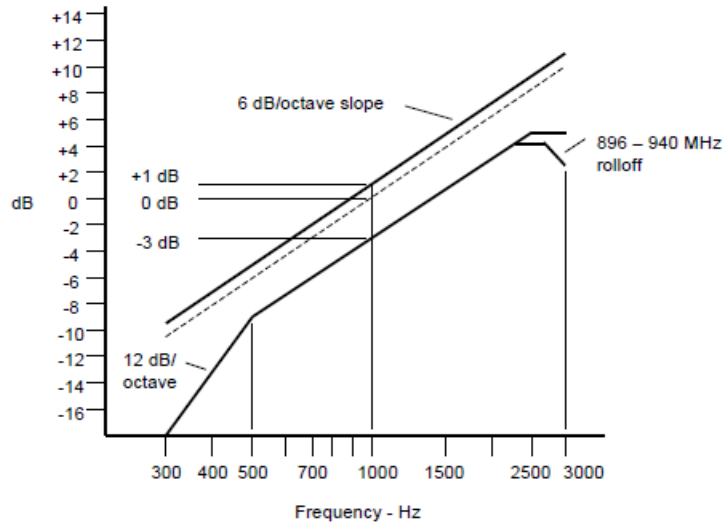

Note:

- o There are additional 6 dB per octave attenuation is allowed from 2.5KHz to 3KHz in equipment 25MHz to 869MHz radio.
- o Additional 6 dB per octave attenuation is allowed from 2.3KHz to 2.7KHz & additional 12 dB per octave attenuation is allowed from 2.7KHz to 3KHz in equipment 896MHz to 940MHz radio.

## 6.4. Modulation Limiting

### 6.4.1. Test Setup

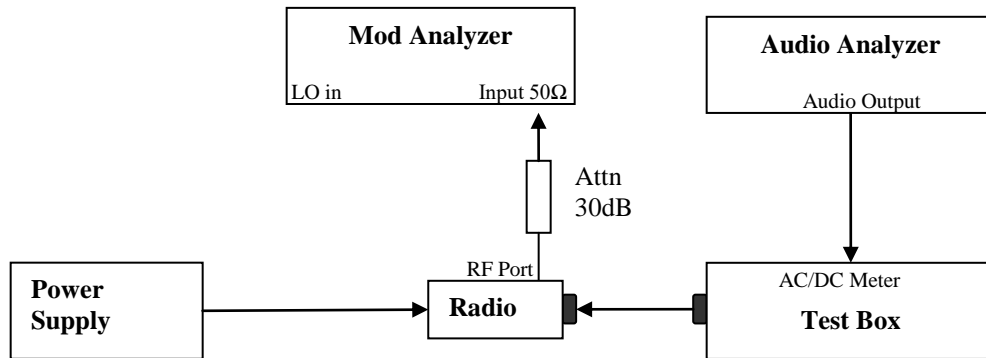

- 1) The DUT transmitter output port was connected to Modulation Analyzer.
- 2) Path loss for the measurement included.
- 3) Set the audio bandwidth filter to 15 kHz.
- 4) Transmit the radio and set the audio analyzer to 1 kHz audio frequency and 60% of the Full rated system deviation.
- 5) Record the frequency deviation as 0dB input level at 1kHz audio frequency.
- 6) Repeat the step and record the frequency deviation from -20 dB to 20dB by 5 dB increments and different audio freq 300 Hz, 2.5 kHz and 3 kHz.

**6.4.2. Test Result**  
Not for FCC review

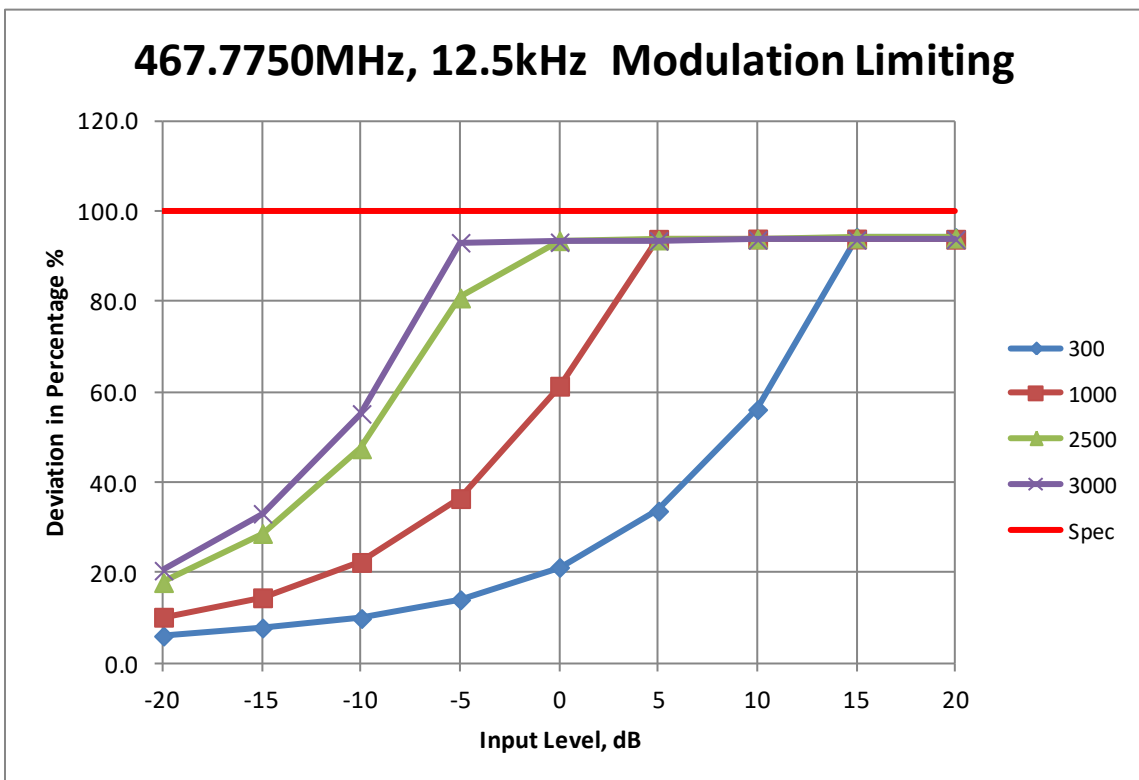
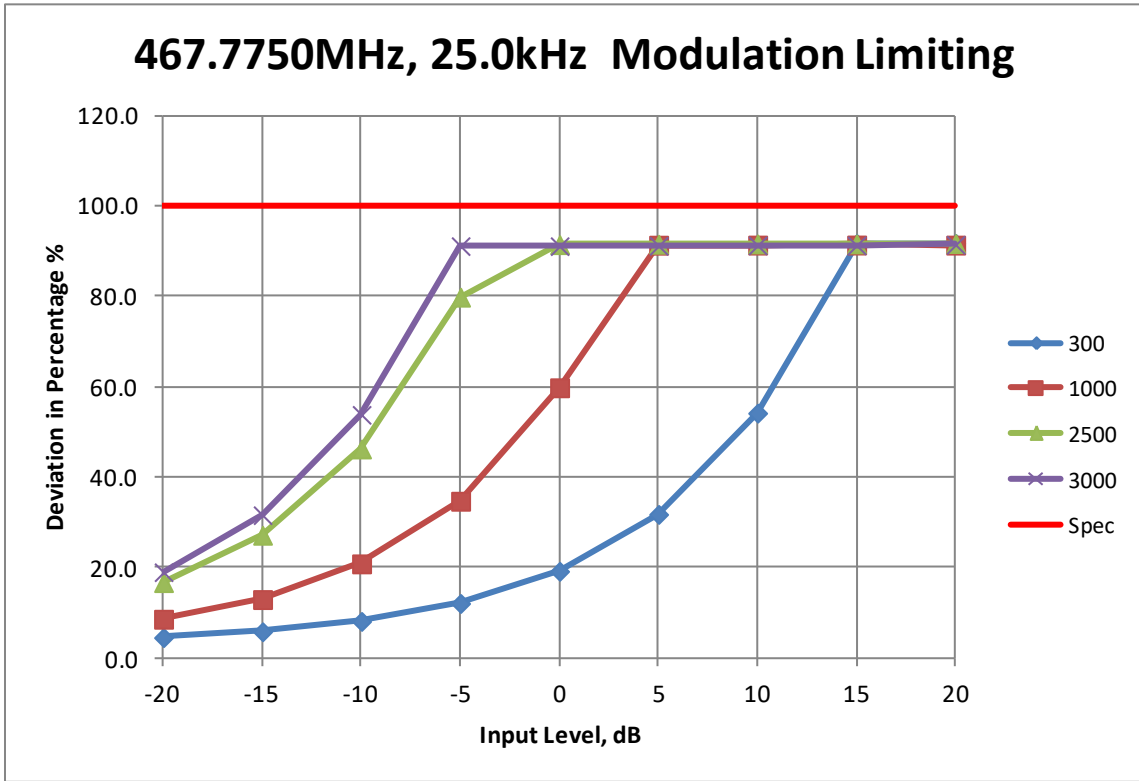

Not for FCC review

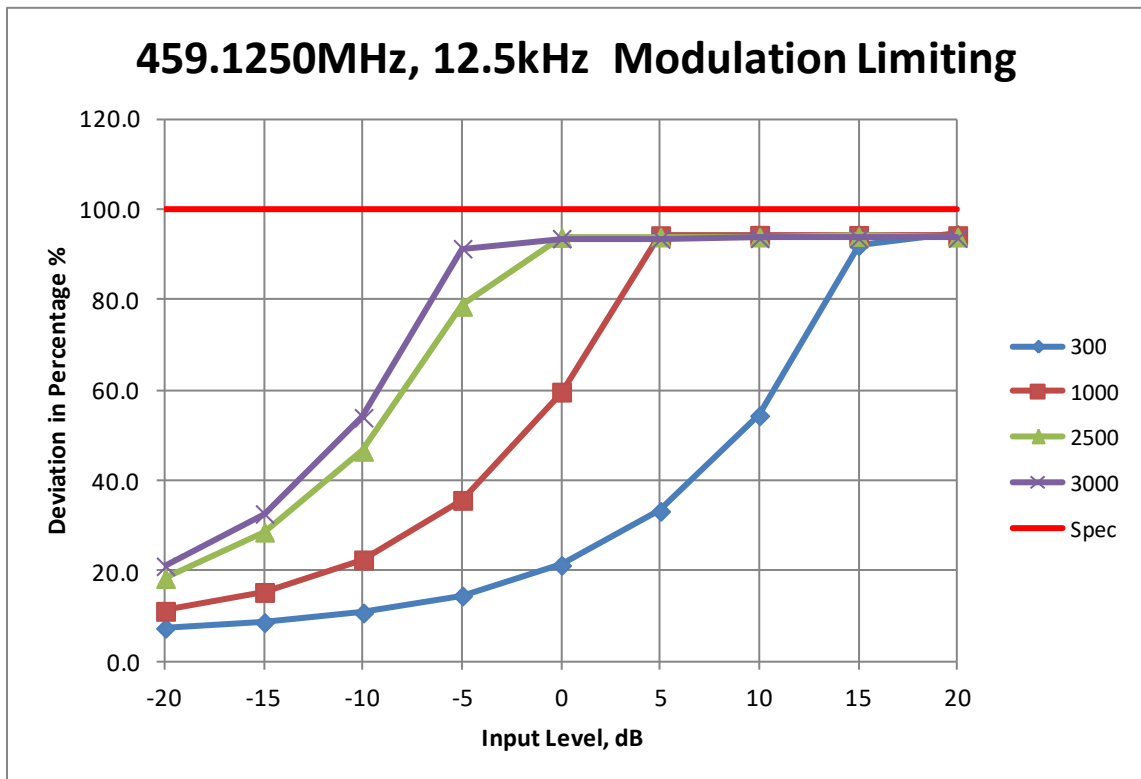
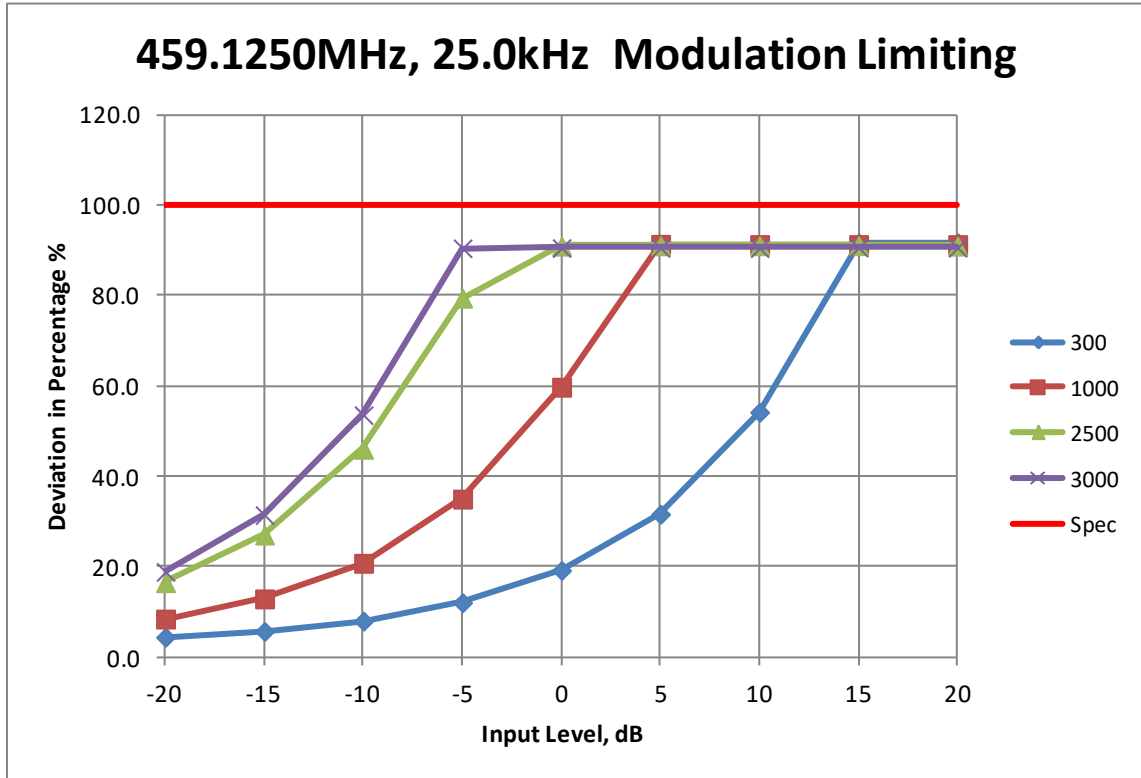

**6.4.3. Test Limit**  
Modulation Limiting shall not exceed 100 percent.

## 6.5. Occupied Bandwidth

### 6.5.1. Test Setup (Analog)

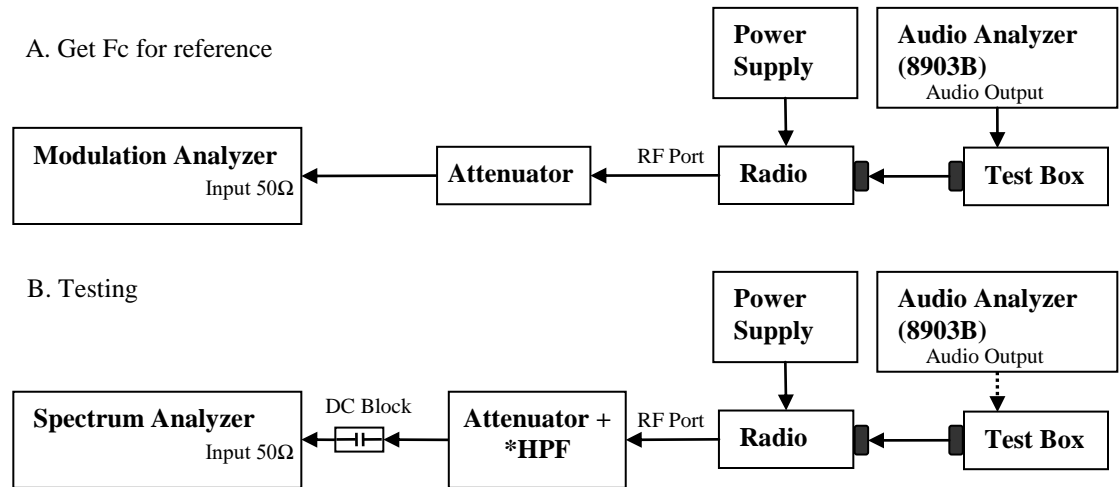

- 1) The DUT transmitter output port was connected to Modulation Analyzer.
- 2) Set the audio bandwidth filter to 15 kHz low pass filter and 50 kHz high pass filter.
- 3) Transmit the radio and set the audio analyzer to 2.5 kHz audio frequency and 50% of the rated deviation. Up the amplitude by 16 dB. Dekey the DUT.
- 4) Path loss for the measurement included.
- 5) Select the Occupied Bandwidth measurement for 99% Emissions Bandwidth Measurement.
- 6) Key in the Fc and Resolution Bandwidth (1 ~ 5 % of emission designator).
- 7) Transmit the DUT and record the occupied Bandwidth frequency.
- 8) Preset the spectrum analyzer for sideband spectrum measurement.
- 9) Set the span and Resolution Bandwidth (according to FCC/ ISED standard).
- 10) Save the screen shot as modulated signal
- 11) Remove the audio tone from audio analyzer to capture unmodulated signal.

\* Only HPF added for Mask 80.211 measurement with attenuator.

\* 99% Bandwidth measurement is computed by the spectrum analyzer and is consistent with the C63.26 5.4.4 method.

### 6.5.2. Test Result (Analog)

Standard Audio Modulation (25 kHz Channelization, Analog Voice):  
 Emission Designator 16K0F3E

In this case, the maximum modulating frequency is 3 kHz with a 5 kHz deviation.

$BW = 2(M+D) = 2*(3 \text{ kHz} + 5 \text{ kHz}) = 16 \text{ kHz} = 16K0$   
 F3E portion of the designator indicates voice.

Therefore, the entire designator for 25 kHz channelization analog voice is 16K0F3E.

Standard Audio Modulation (12.5 kHz Channelization, Analog Voice):  
 Emission Designator 11K0F3E

In this case, the maximum modulating frequency is 3.0 kHz with a 2.5 kHz deviation.

$BW = 2(M+D) = 2*(3.0 \text{ kHz} + 2.5 \text{ kHz}) = 11 \text{ kHz} = 11K0$   
 F3E portion of the designator indicates voice.

Therefore, the entire designator for 12.5 kHz channelization analog voice is 11K0F3E.

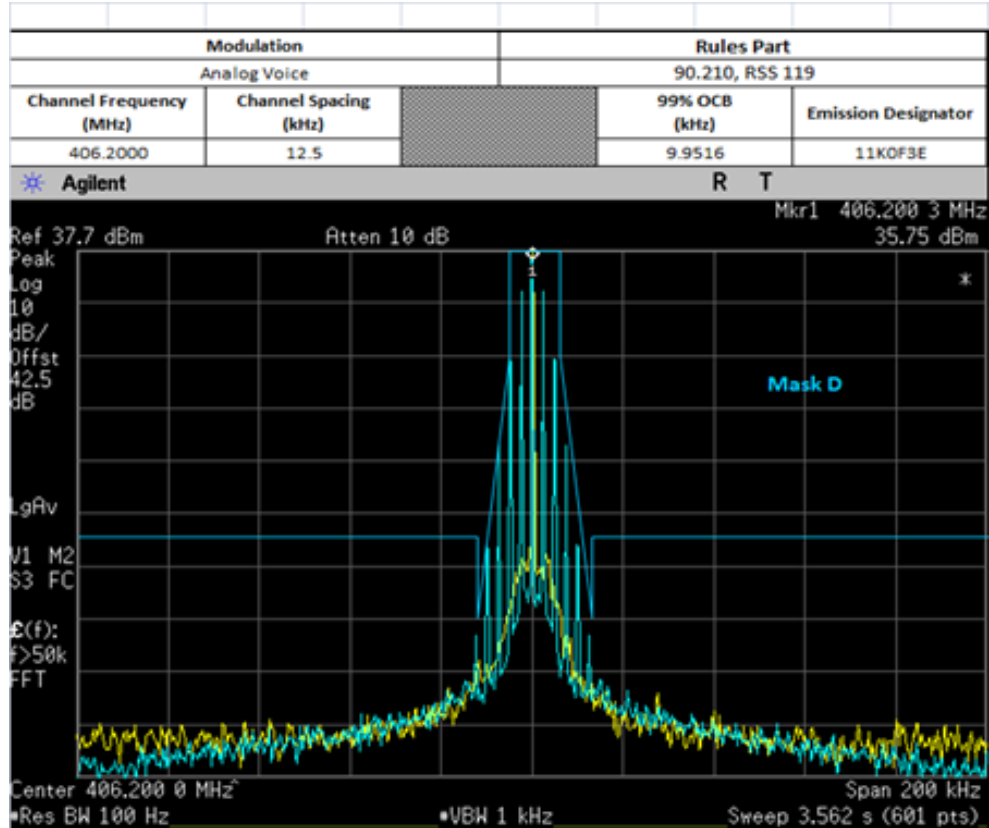

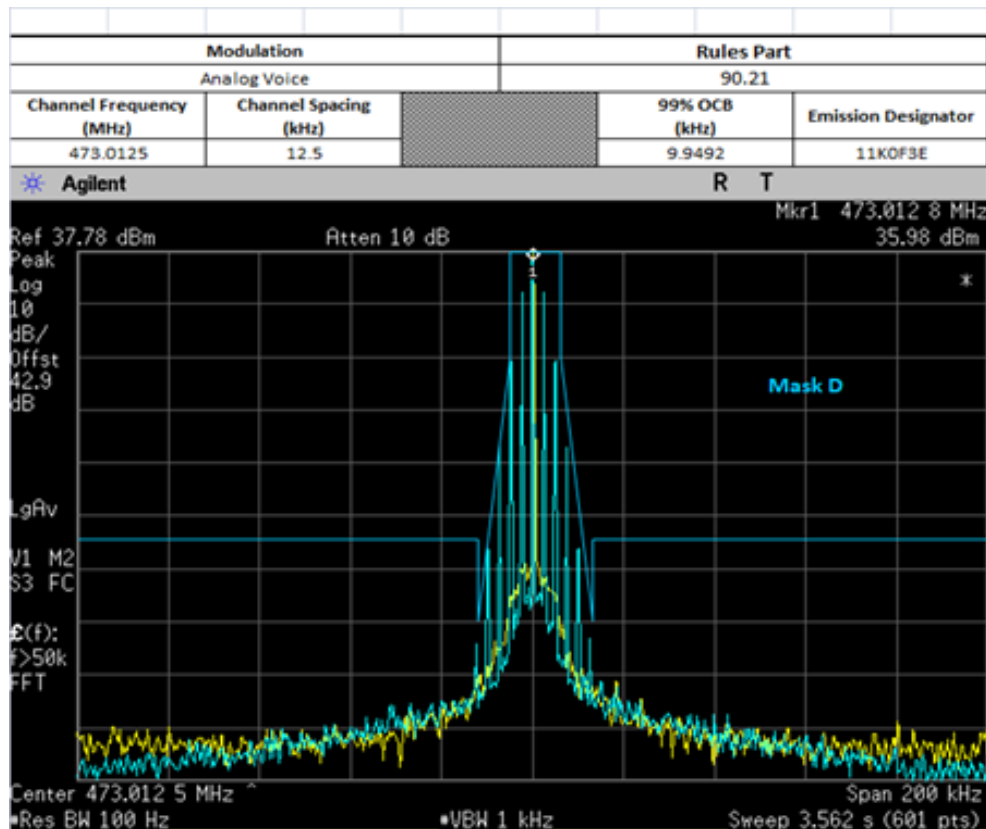
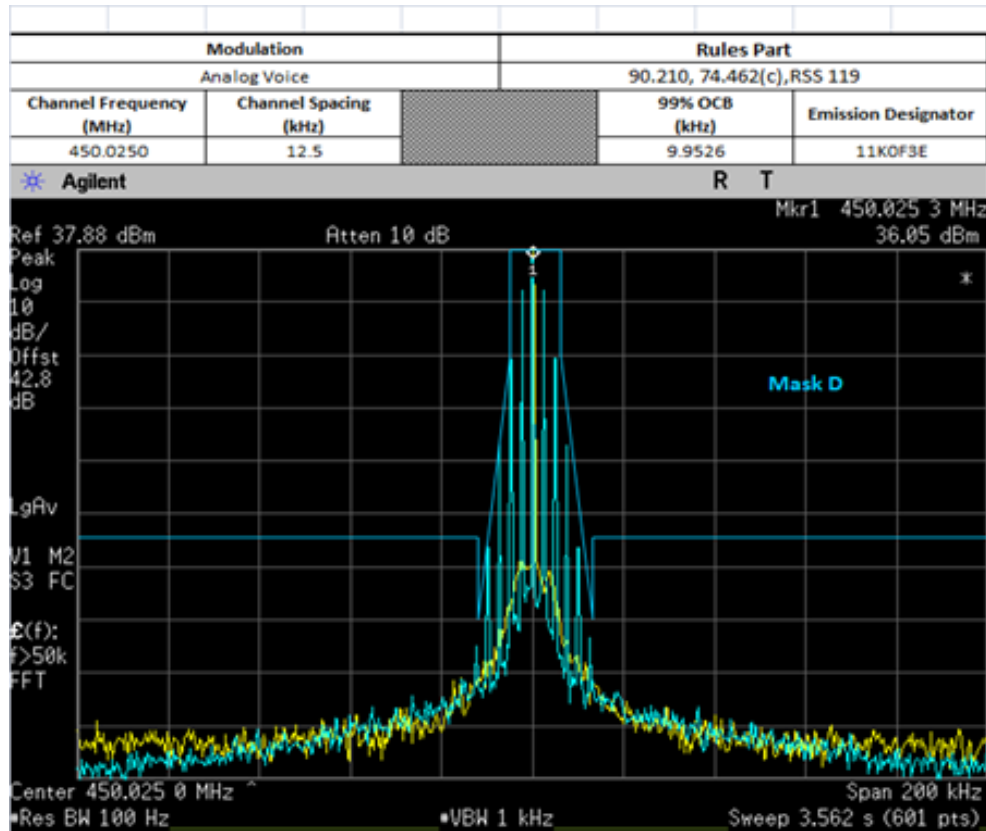



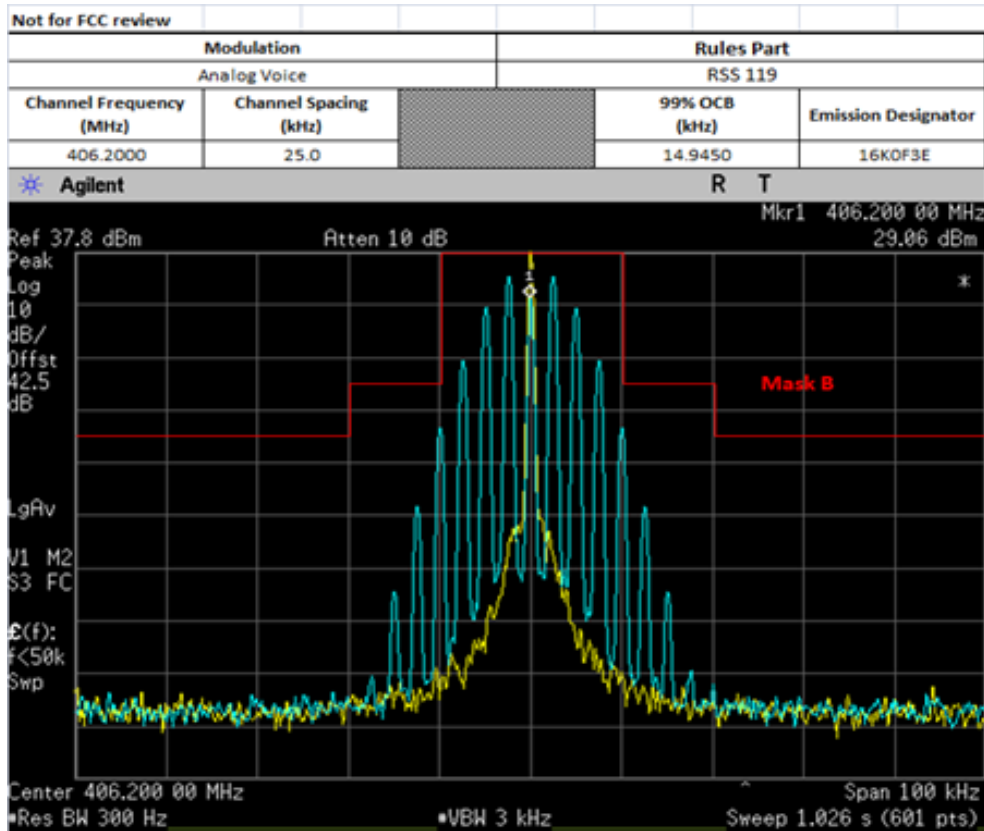
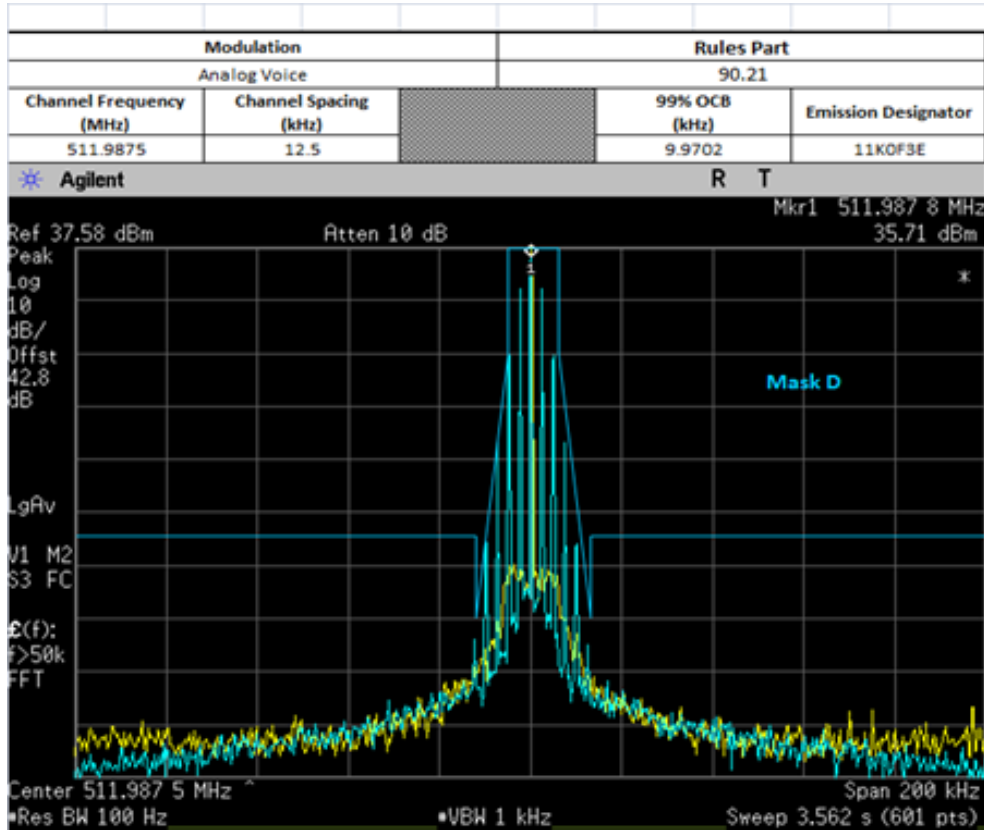

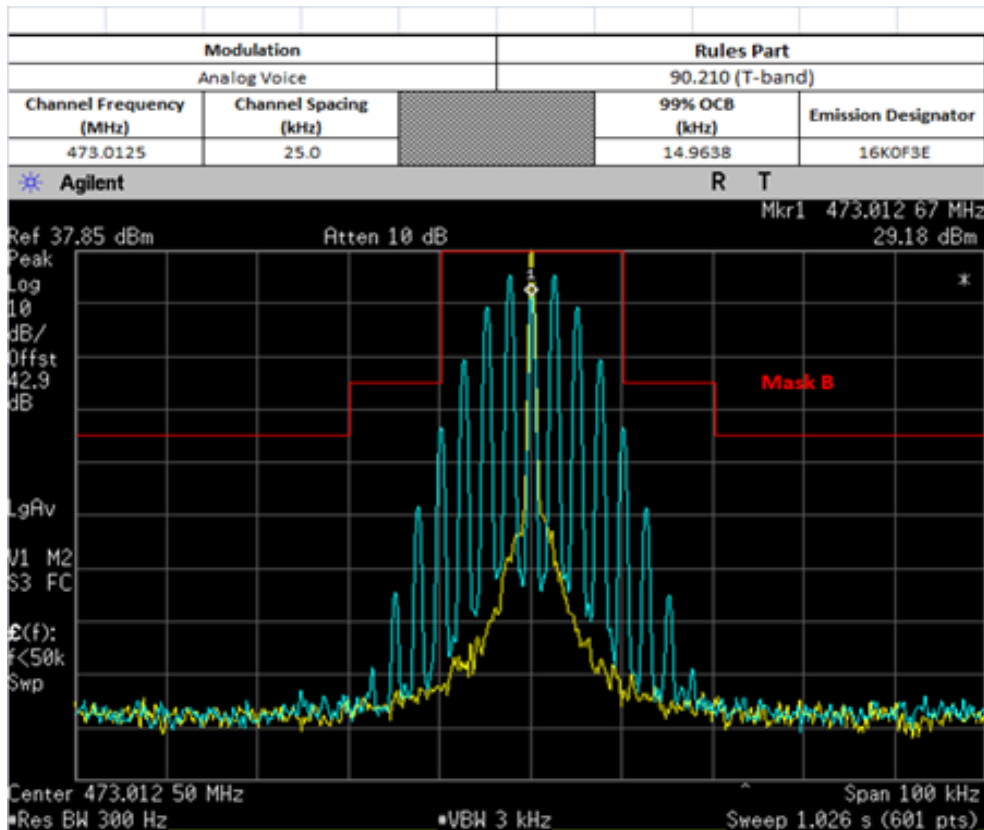
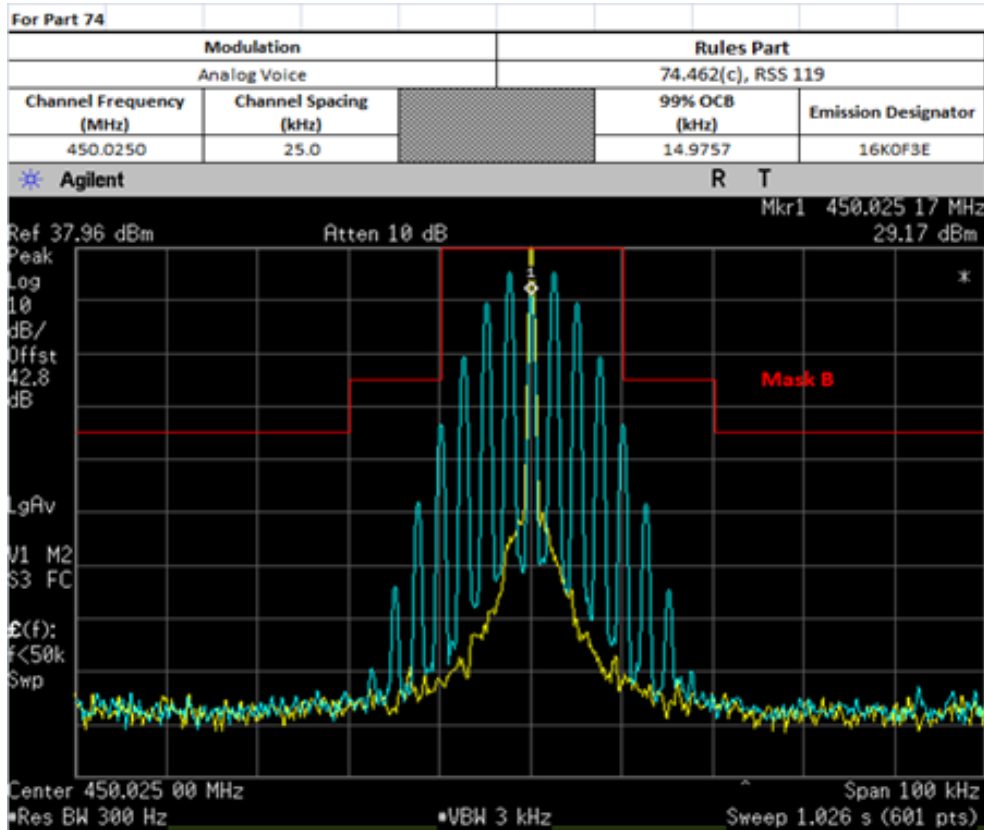

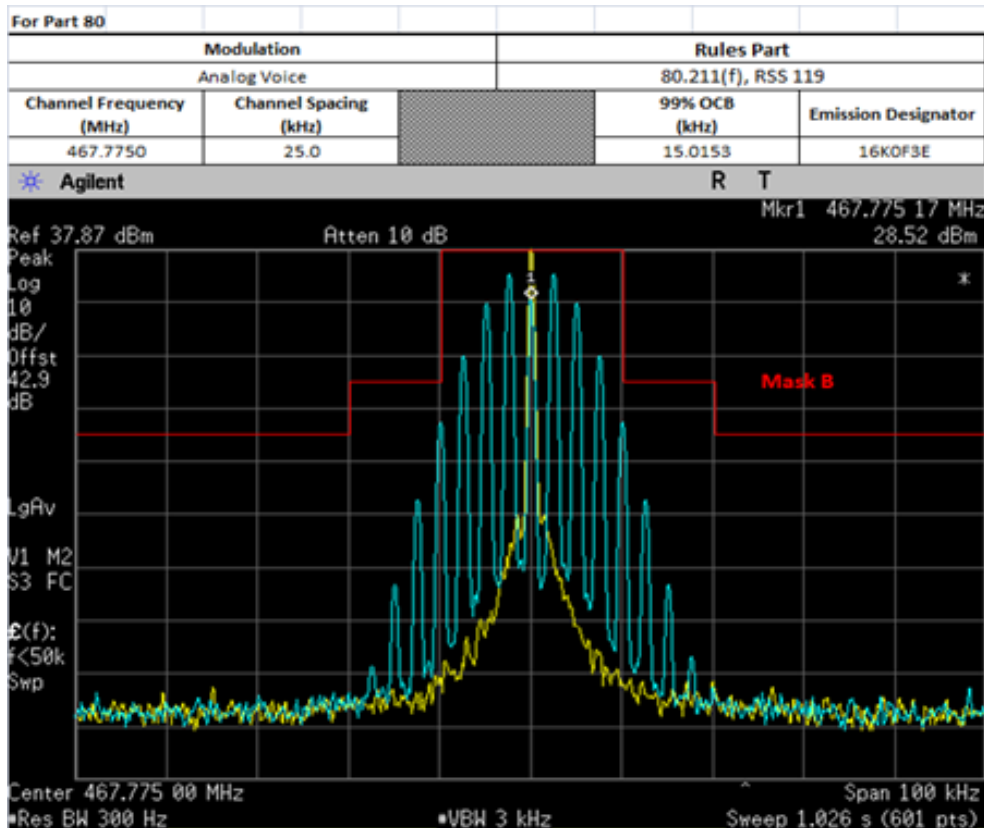
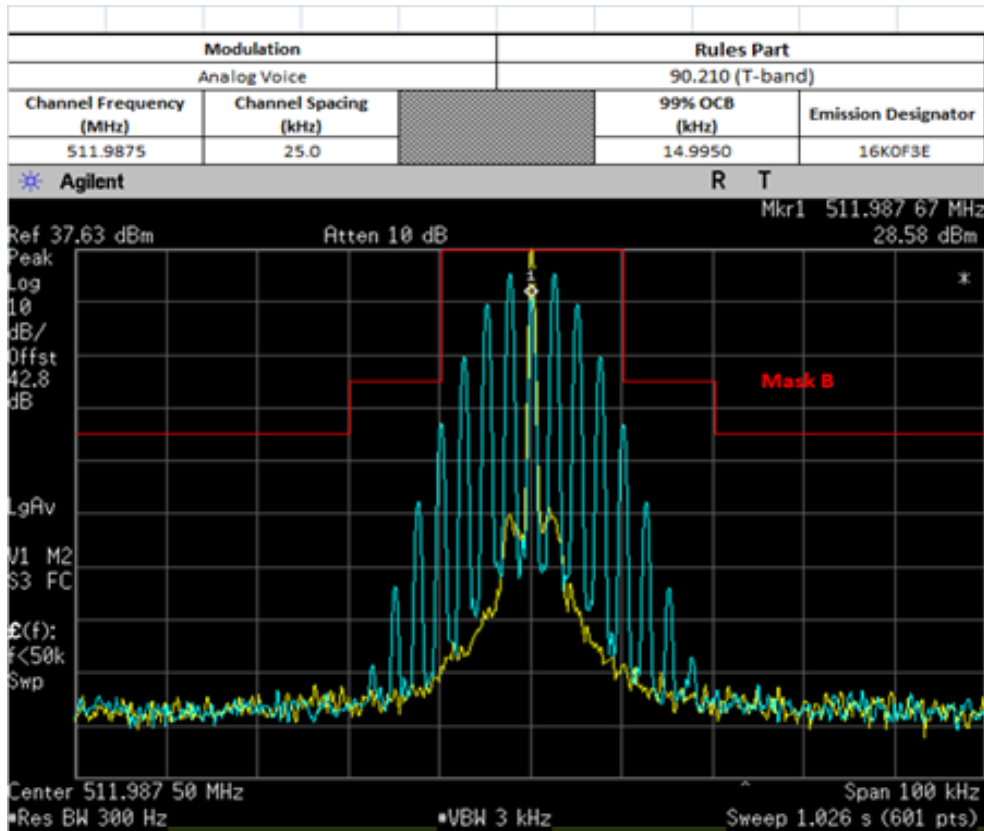

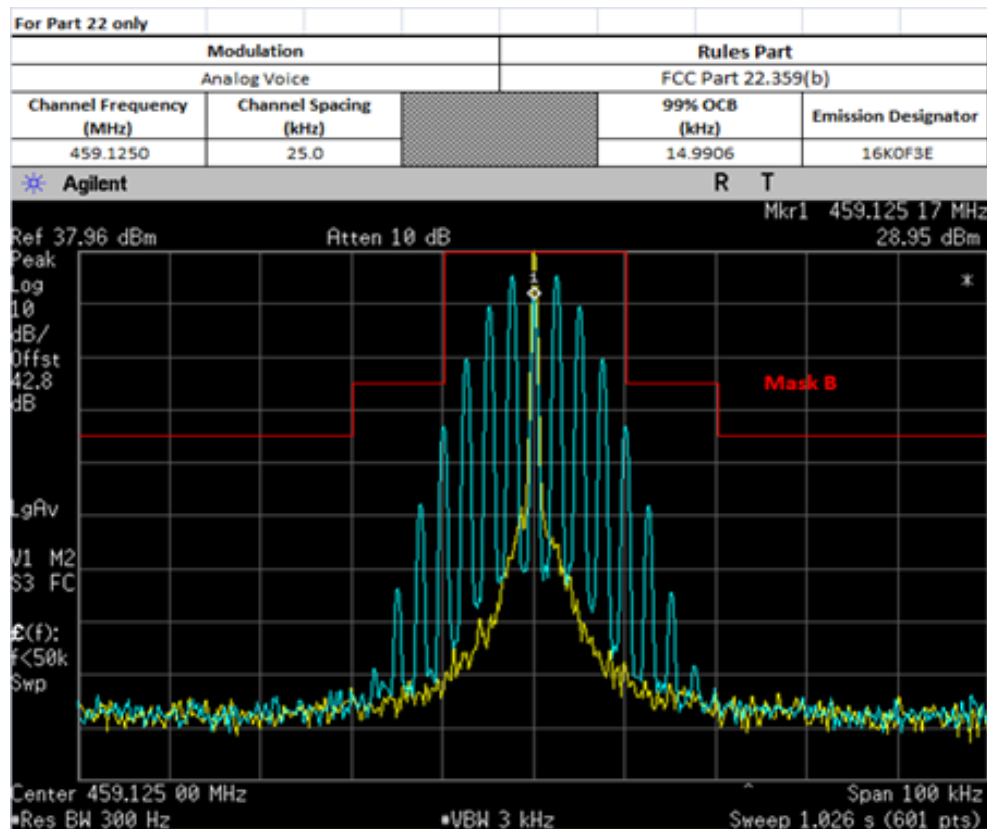
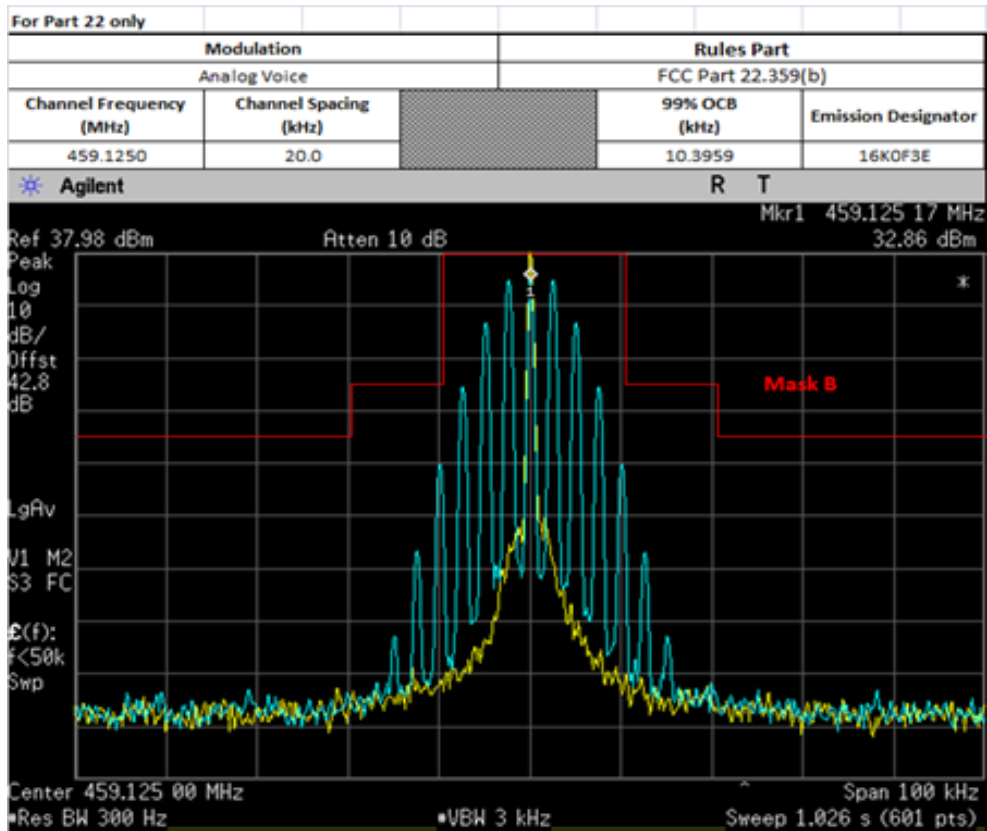

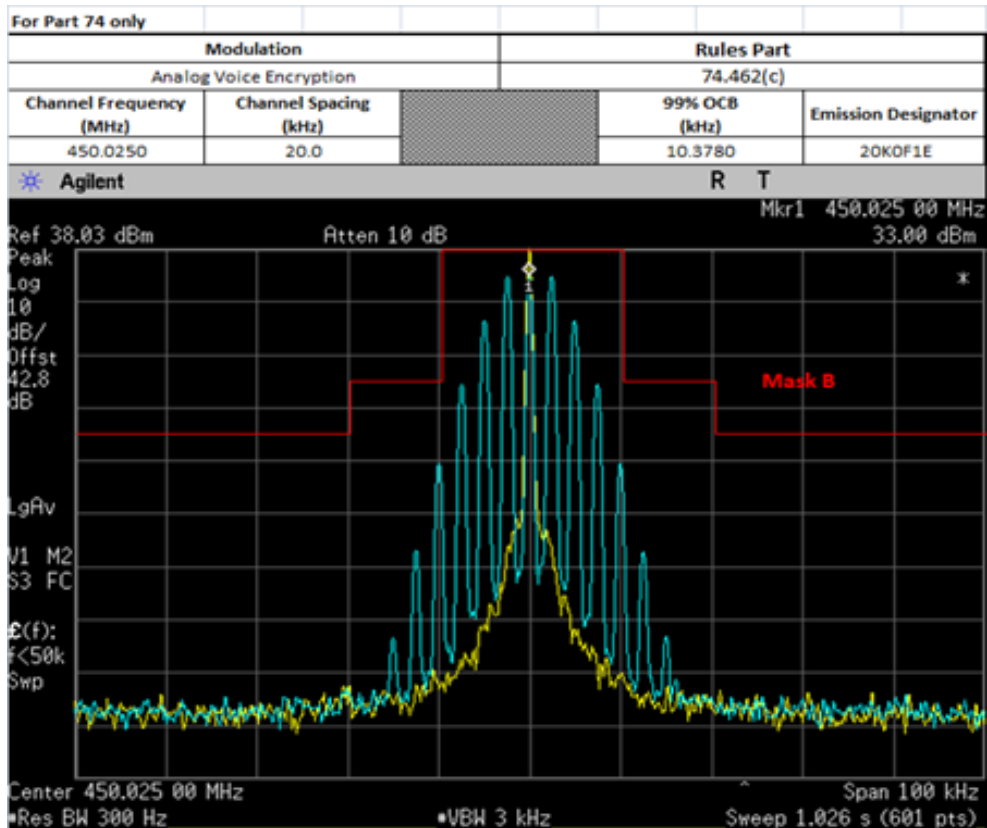
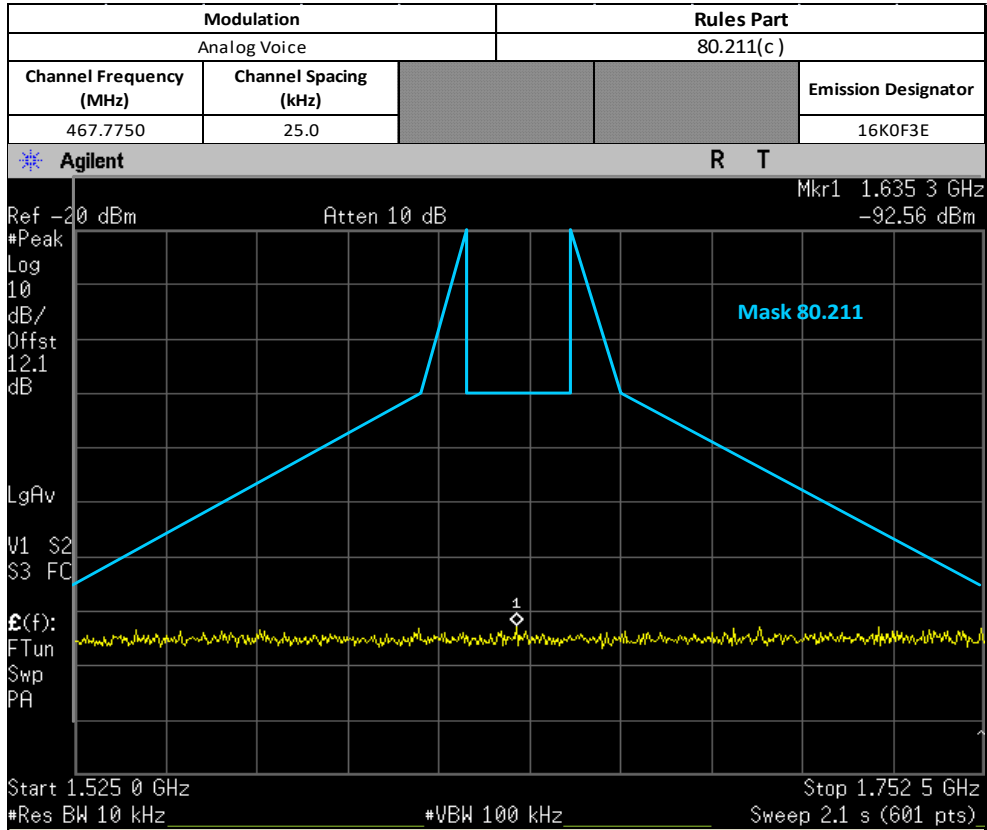

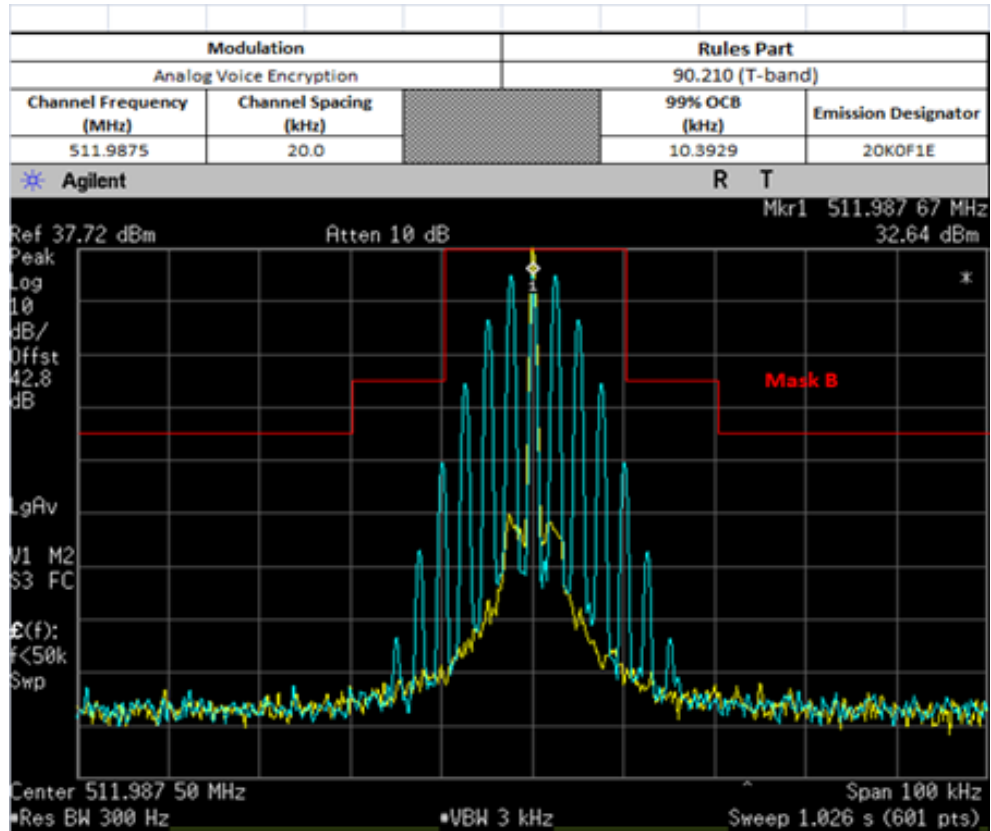

### 6.5.3. Test Setup (Digital)

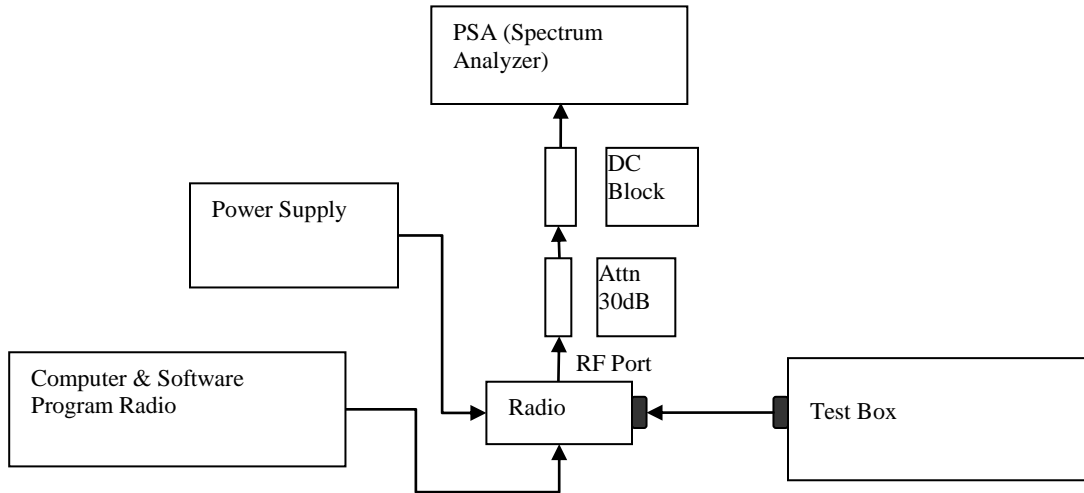

- 1) Program and set radio to operate in desire test frequency and digital mode with modulation. (\*4FSK, C4FM or other digital modulation form).
- 2) Path loss for the measurement included.
- 3) Select the Occupied Bandwidth measurement for 99% Emissions Bandwidth Measurement.
- 4) Key in the Fc and Resolution Bandwidth (1 ~ 5 % of emission designator).
- 5) Transmit the DUT and record the occupied Bandwidth frequency.
- 6) Preset the spectrum analyzer for modulation emission spectrum measurement.
- 7) Set the span and Resolution Bandwidth (according to FCC/ ISED standard).
- 8) Capture the screen shot as modulated signal.

\* 99% Bandwidth measurement is computed by the spectrum analyzer and is consistent with the C63.26 5.4.4 method.

\*Note:

- For Digital Modulation, 12.5 kHz Data F1D & FXD would be the same. Therefore only measurements with F1D modulation shown below.
- For Digital Modulation, 12.5 kHz Data F1E & FXE would be the same. Therefore only measurements with F1E modulation shown below.

### 6.5.4. Test Result (Digital)

Digital (12.5 kHz Channelization, Digital Voice/Data/Voice+Data):  
 Emission Designator 8K10F1E/D/W

The 99% energy rule (title 47CFR 2.989) was used for digital mode and is more accurate than Carson’s rule. It basically states that 99% of the modulation energy falls within X kHz, in this case, 7.60 kHz. Measurements were performed in accordance with TIA/EIA TSB102.CAAB Section 2.2.5.2. The emission mask was obtained from 47CFR 90.210(d).

F1E/D/W portion of the designator indicates digital voice/data/voice+data.

Therefore, the entire designator for 12.5 kHz channelization digital voice is 8K10F1E/D/W.

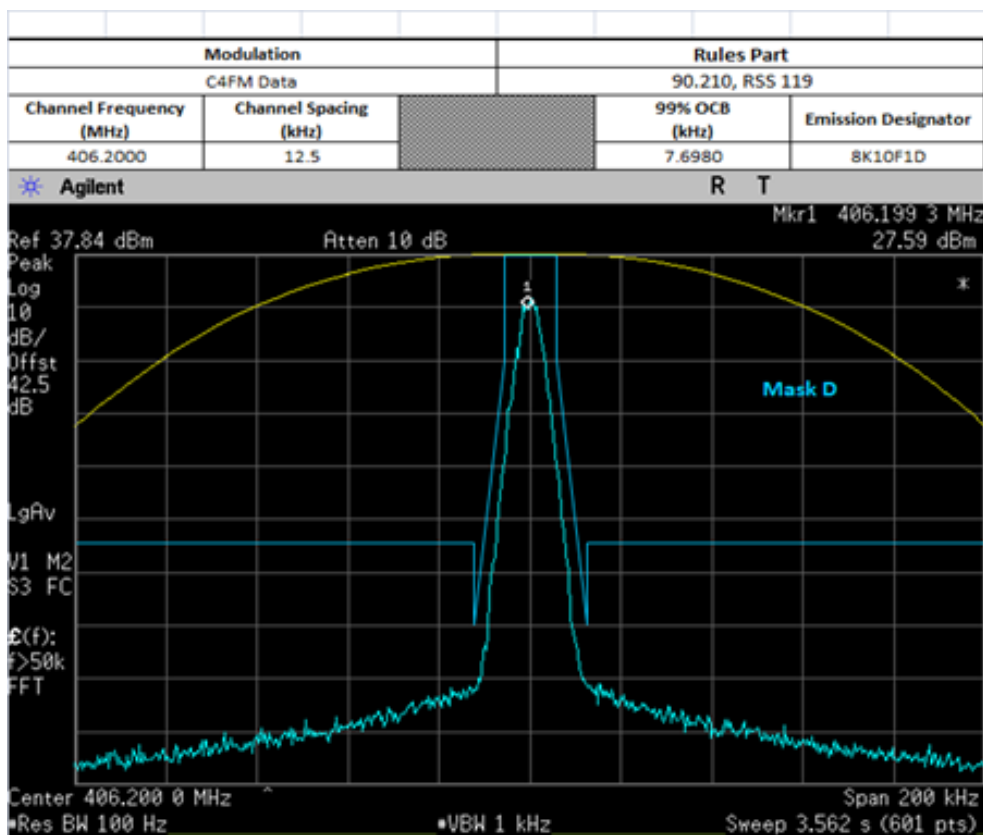



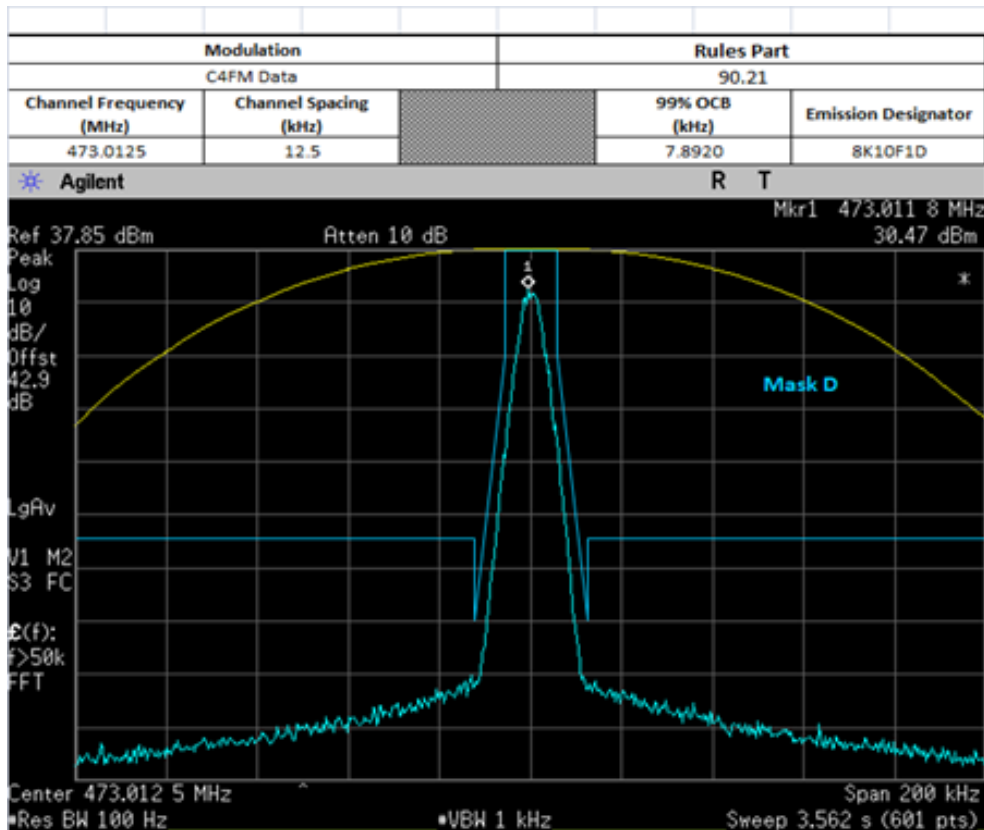
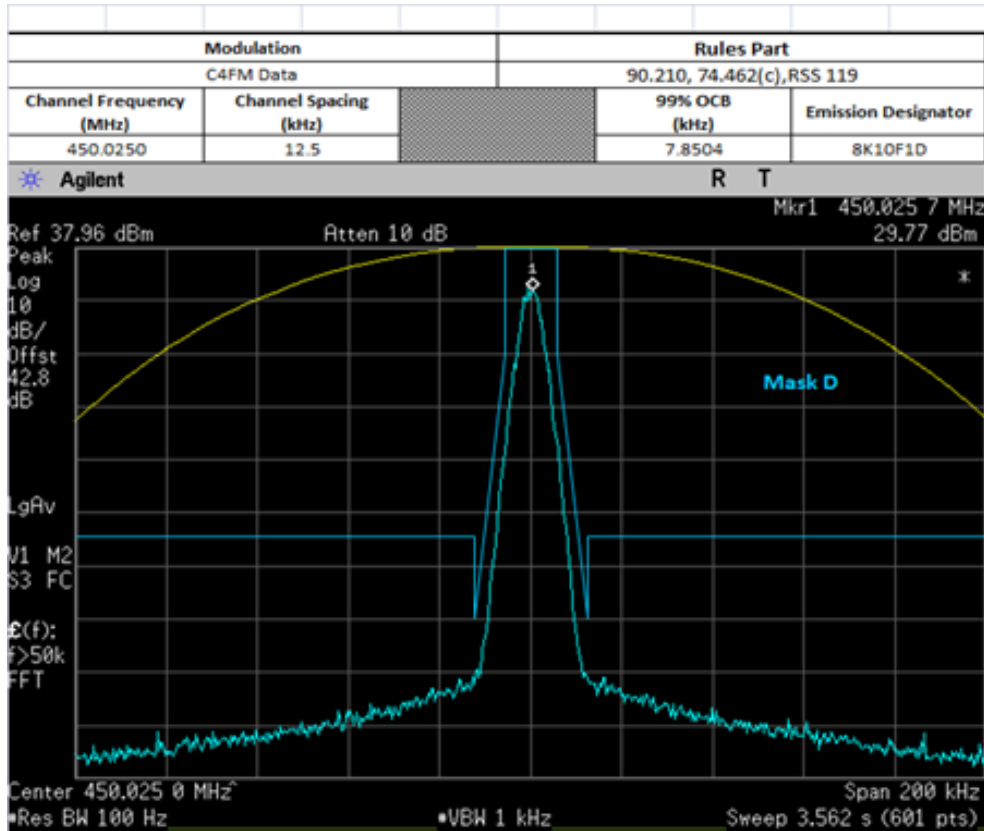

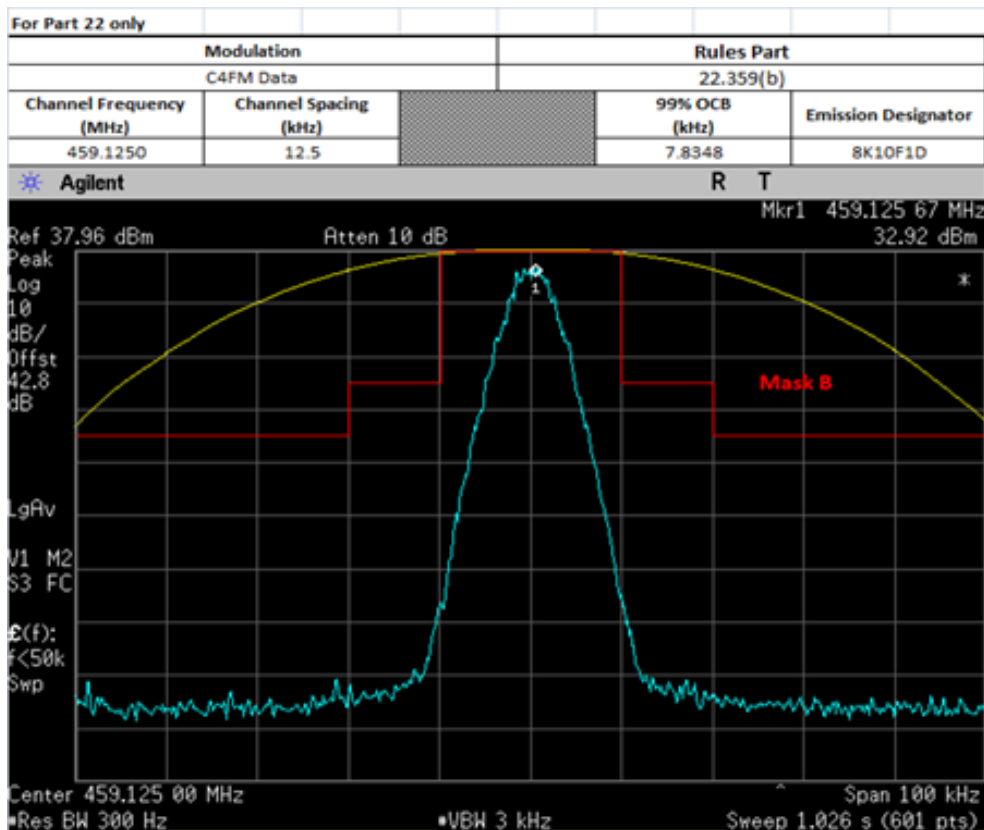
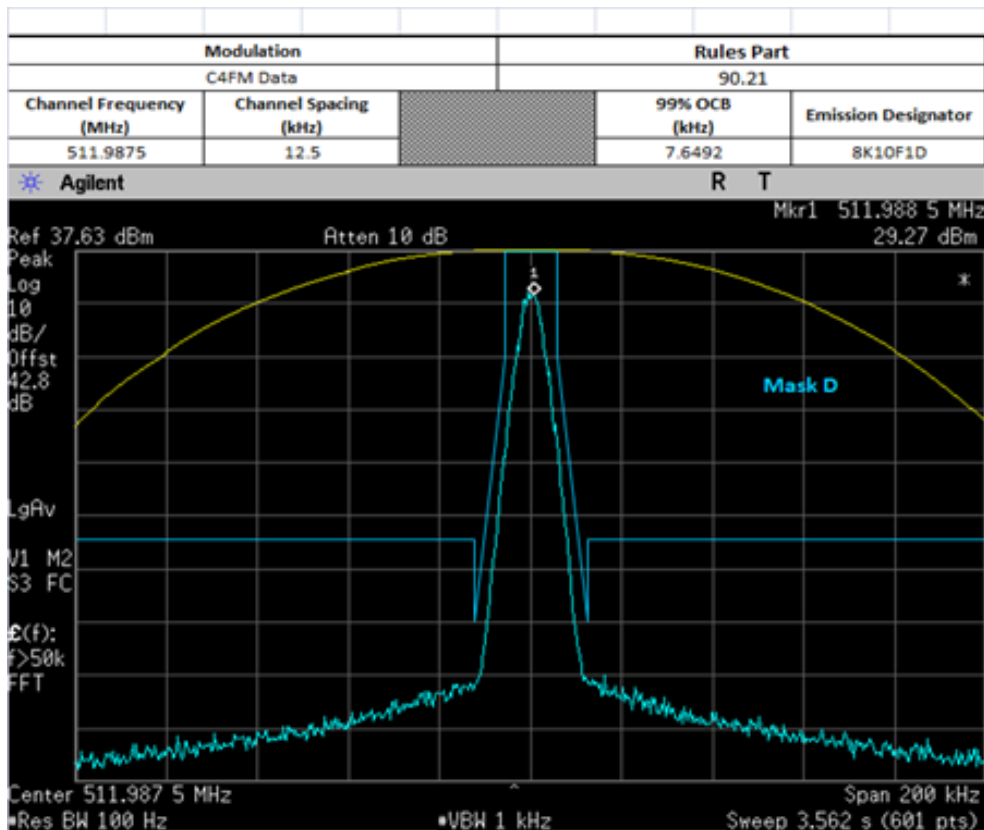

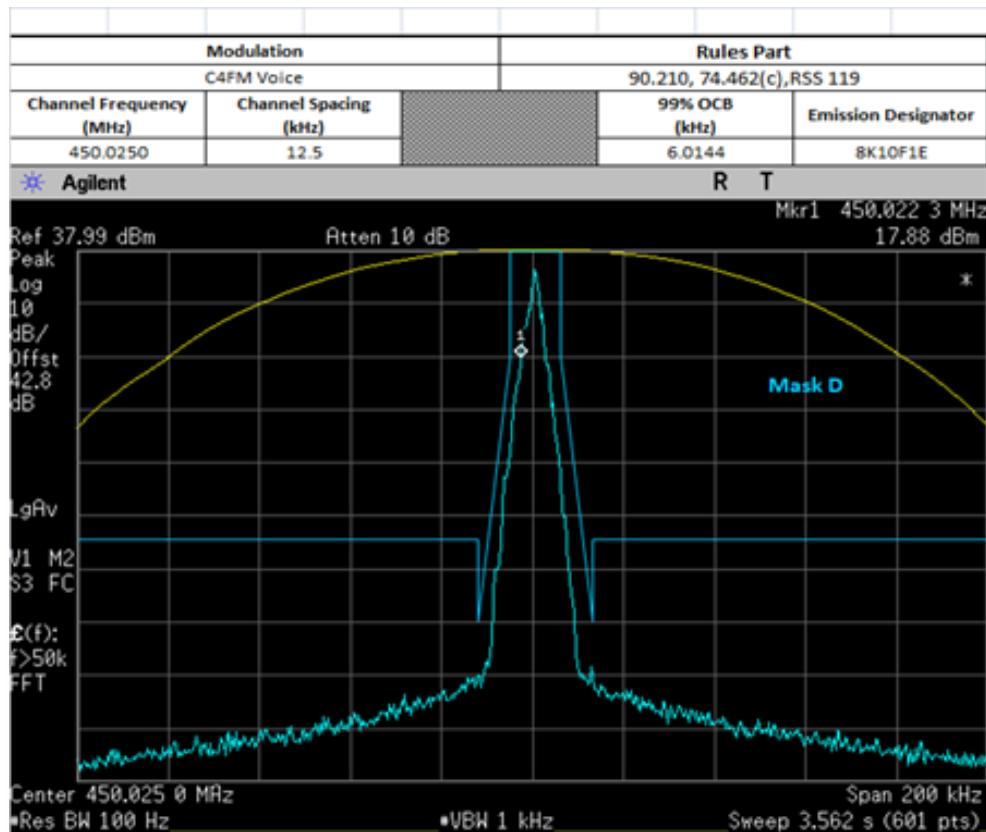
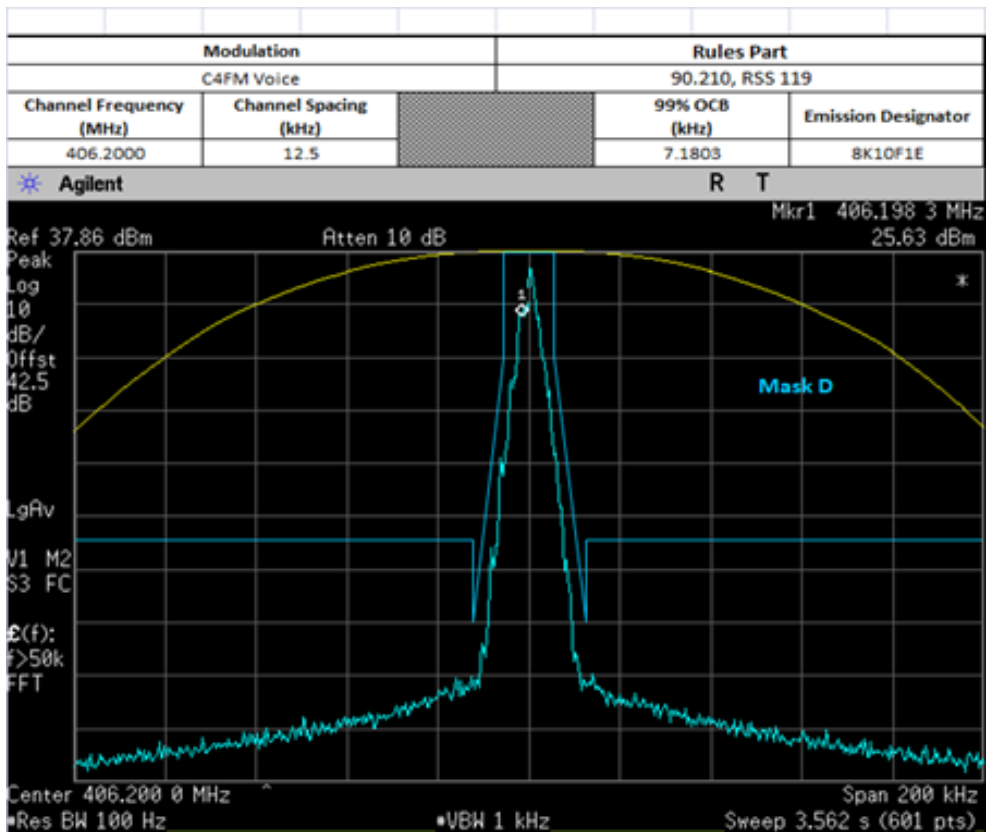

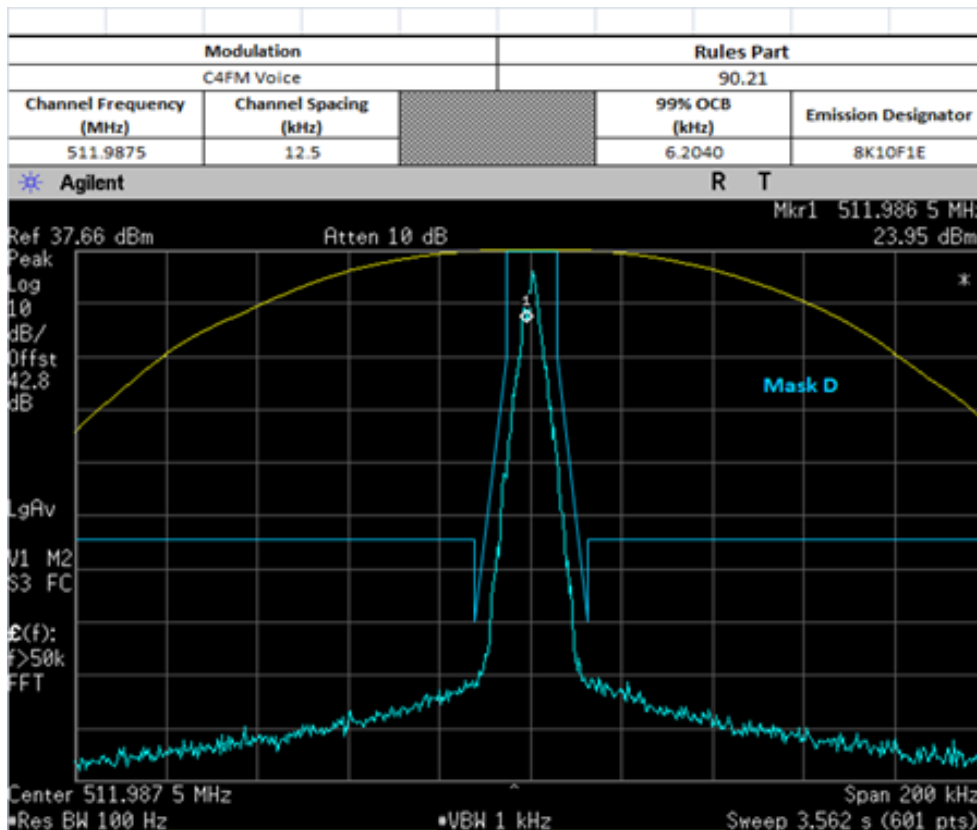
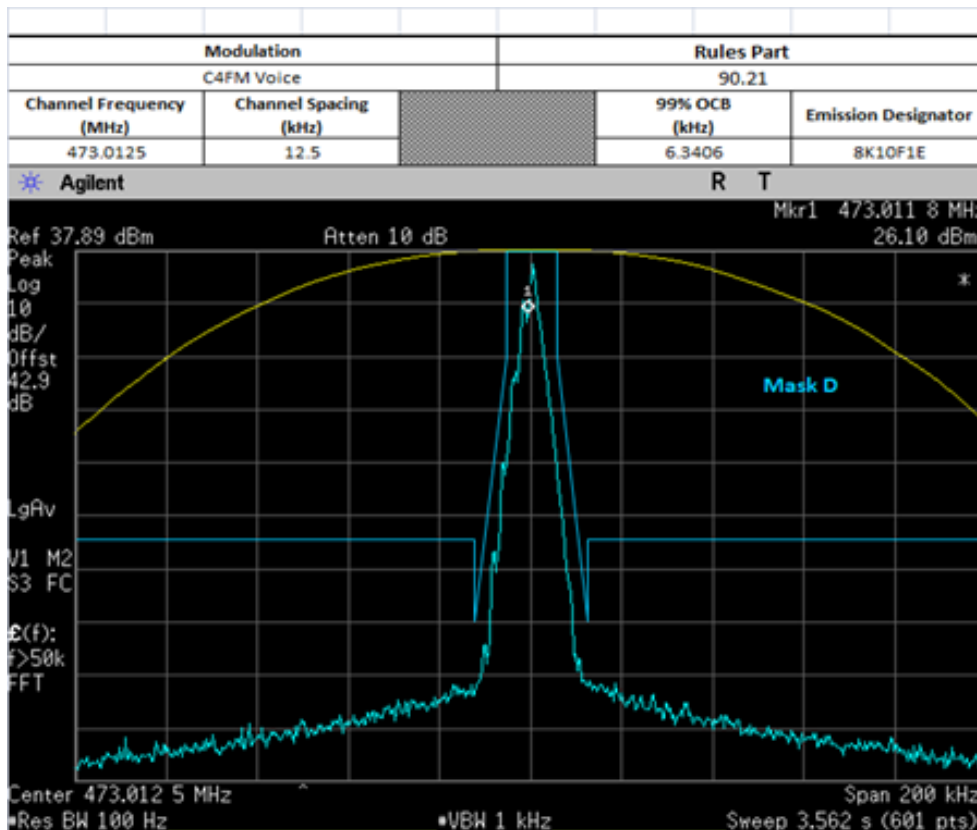

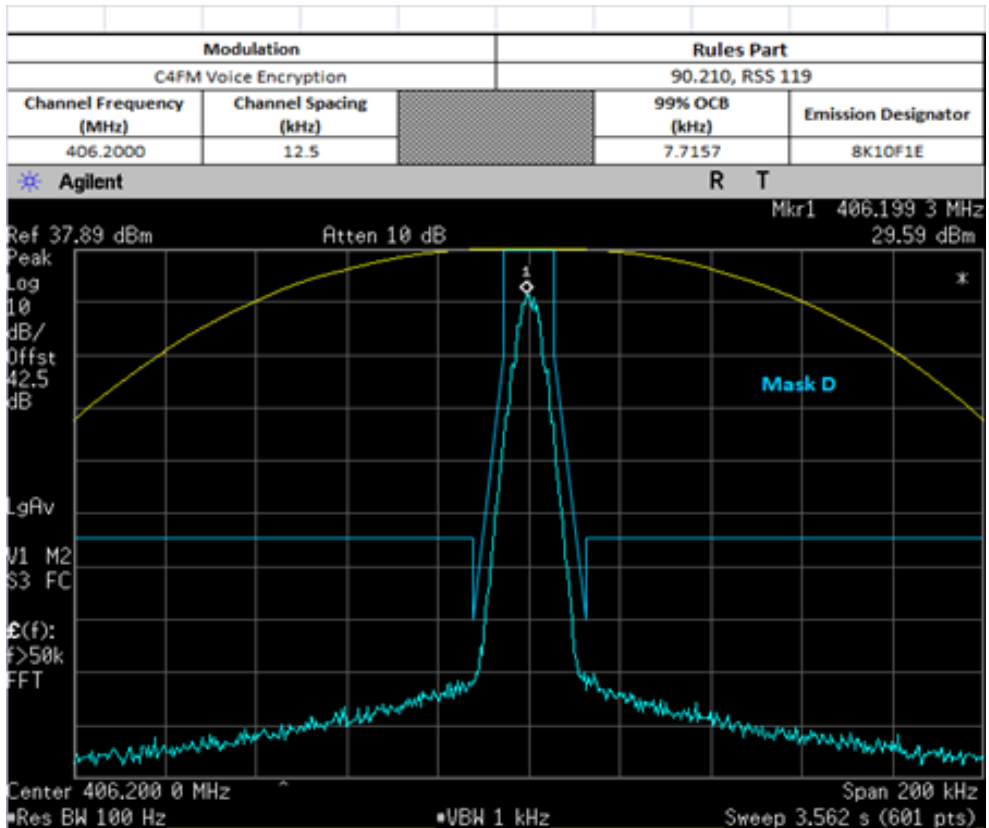
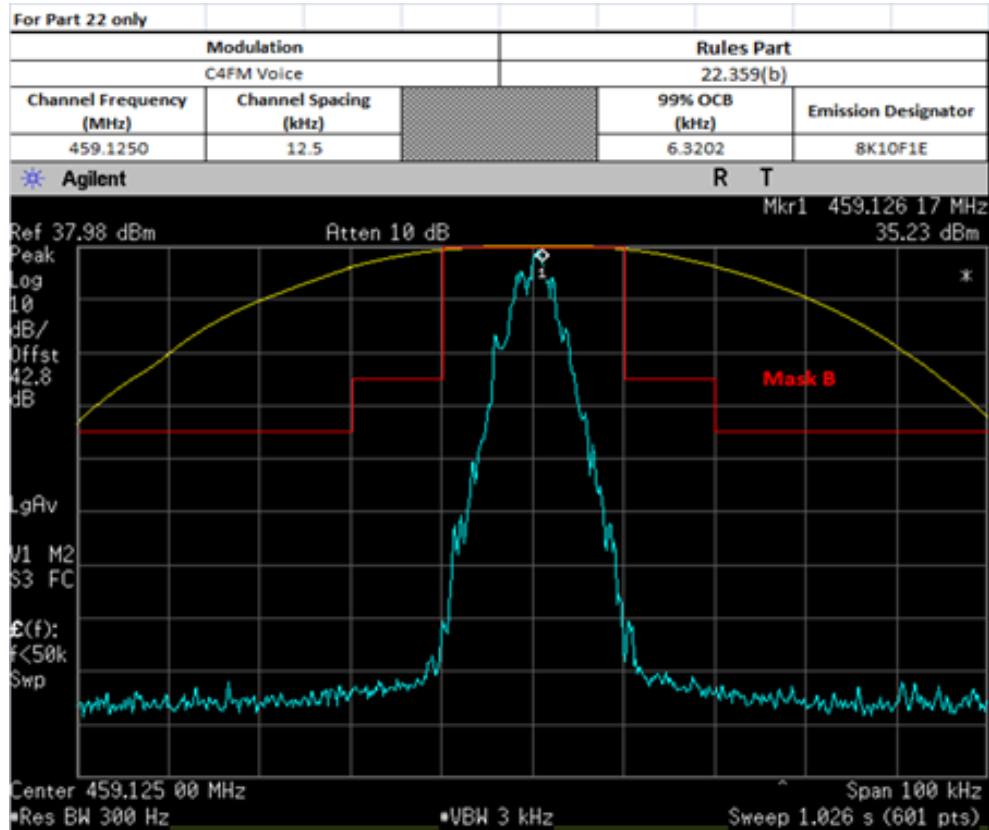

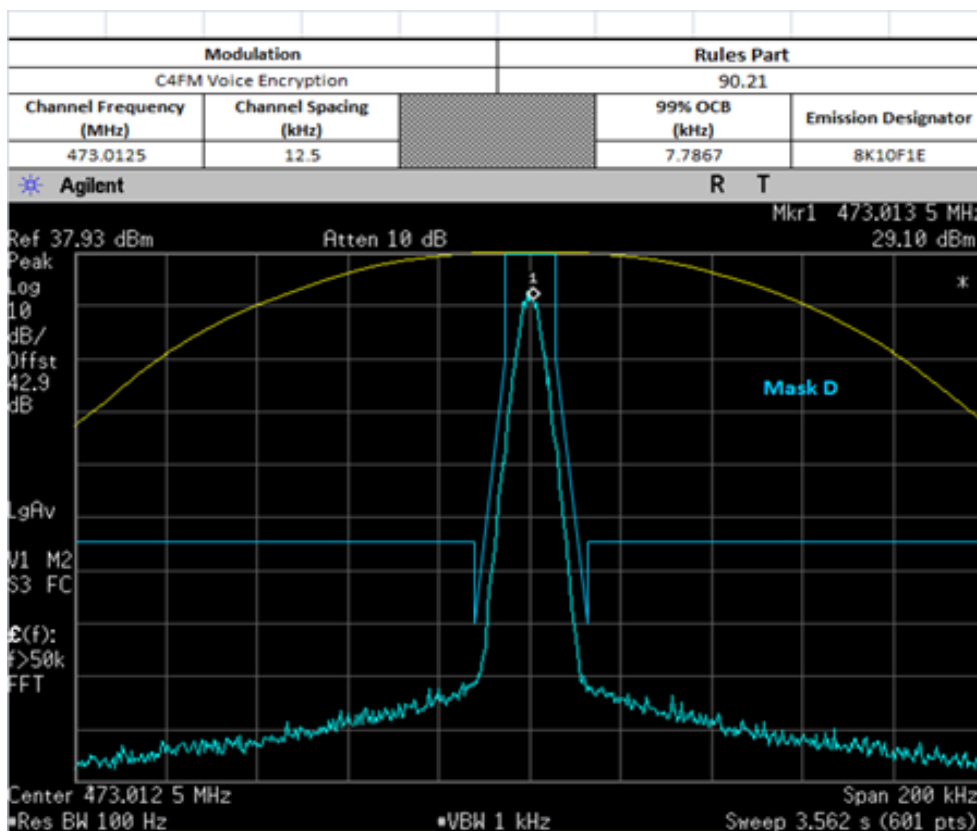
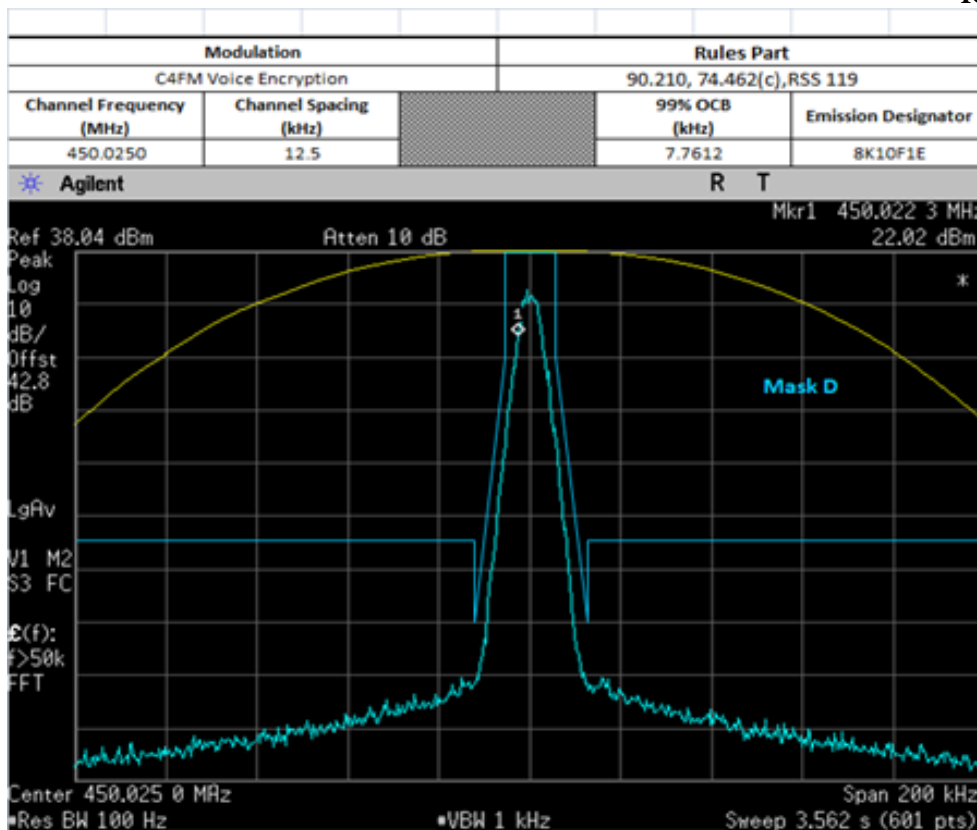

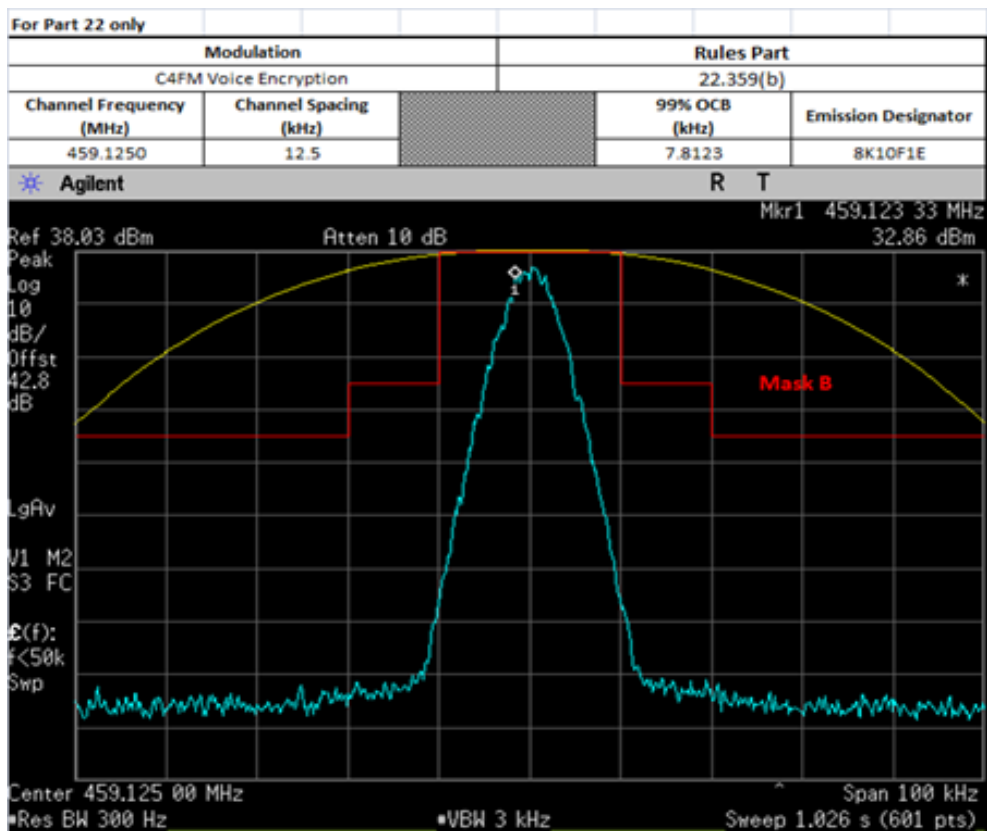
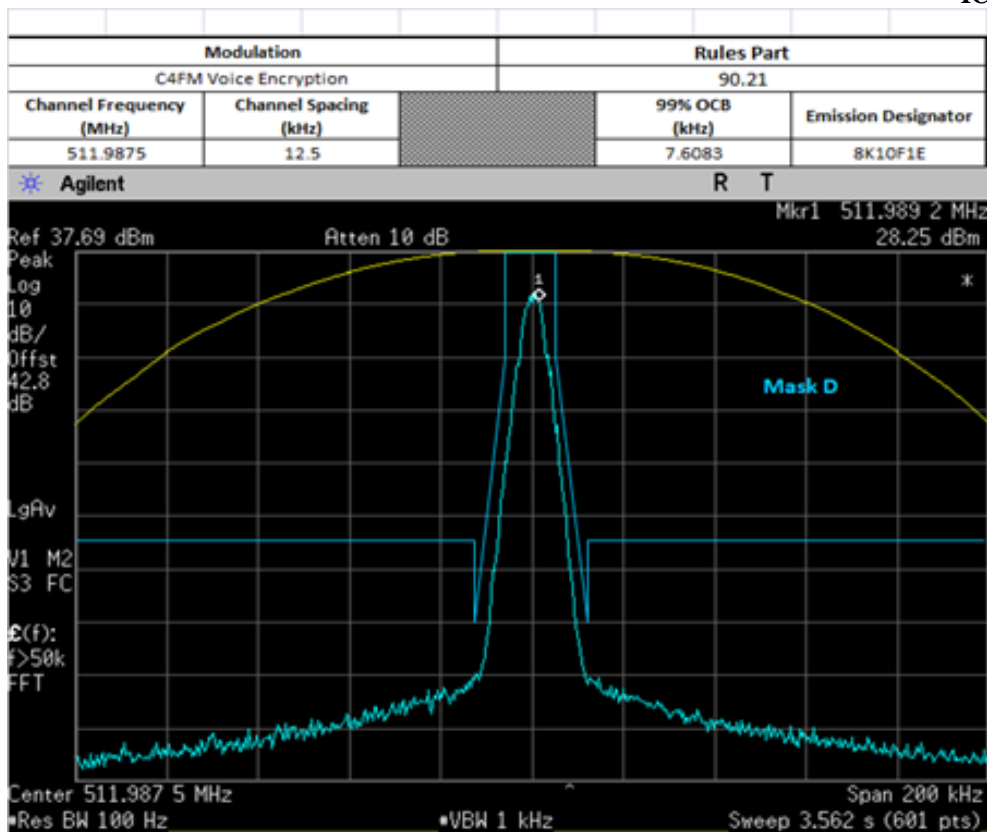

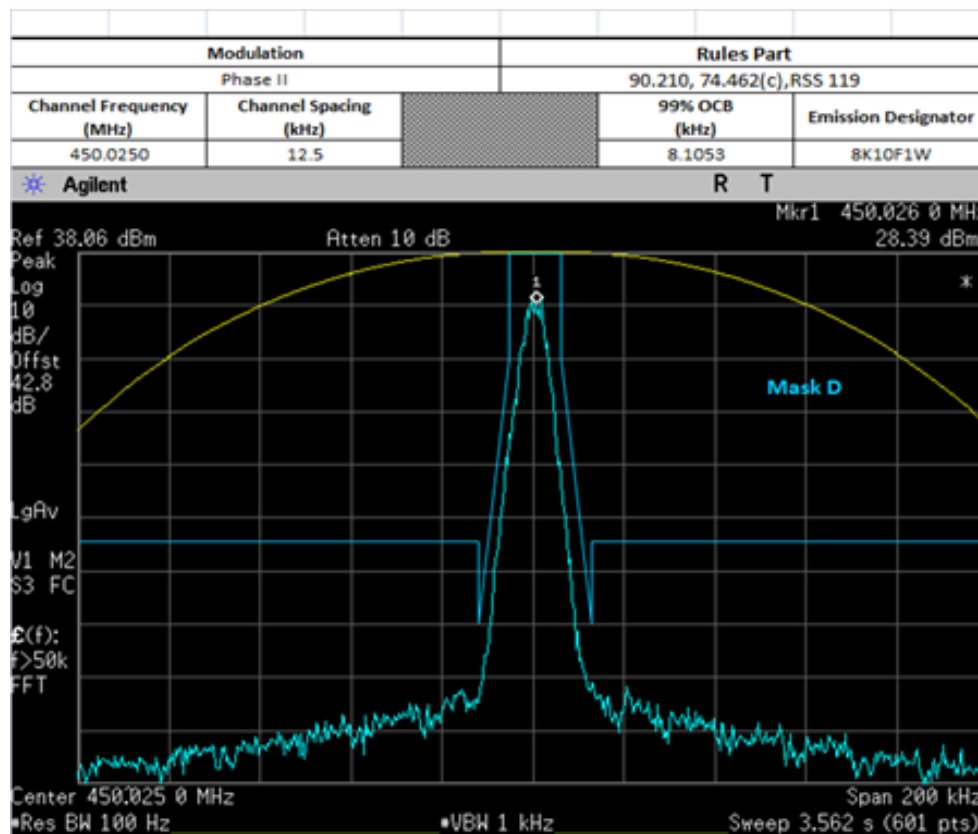
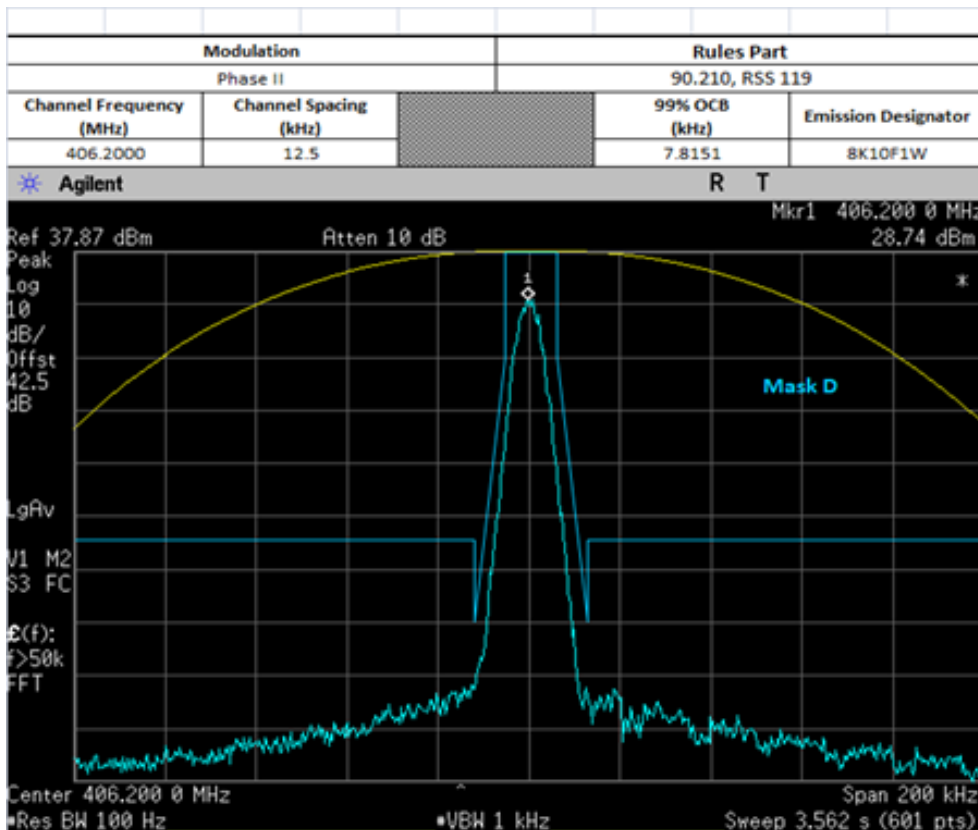



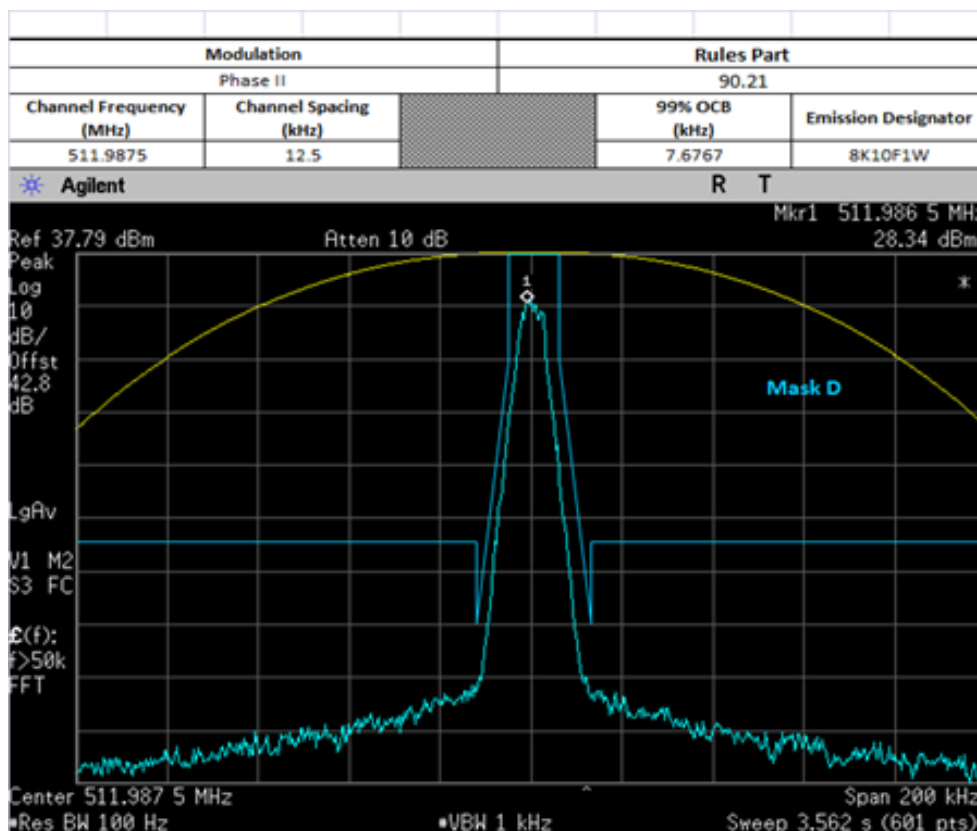
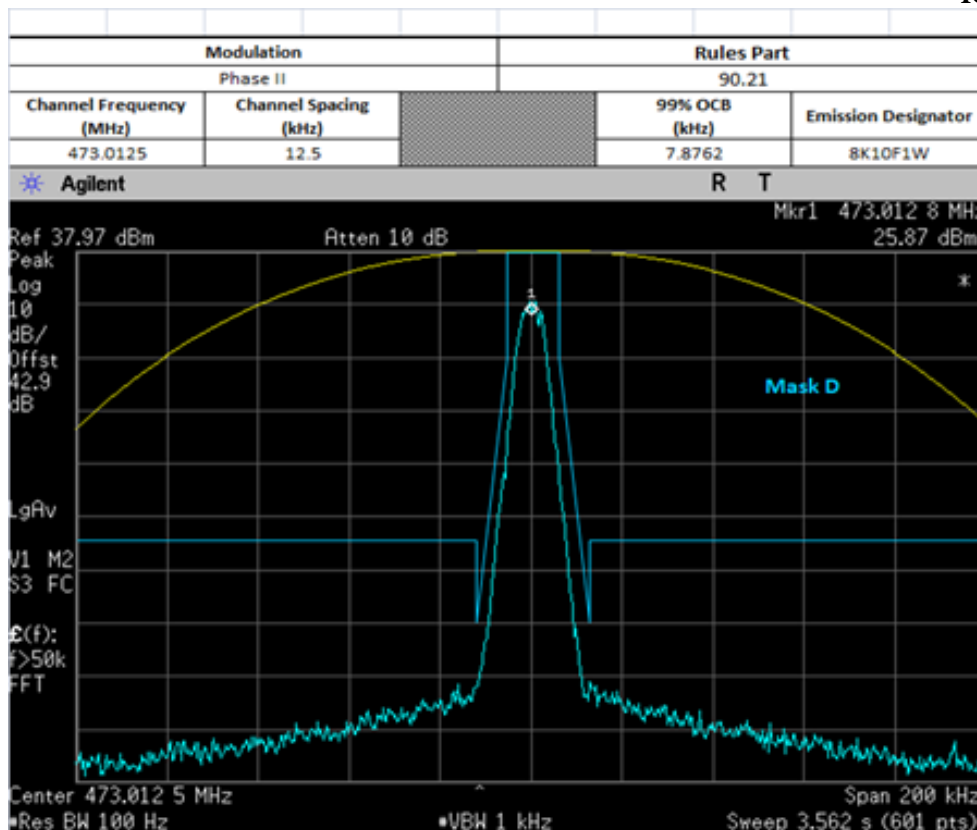

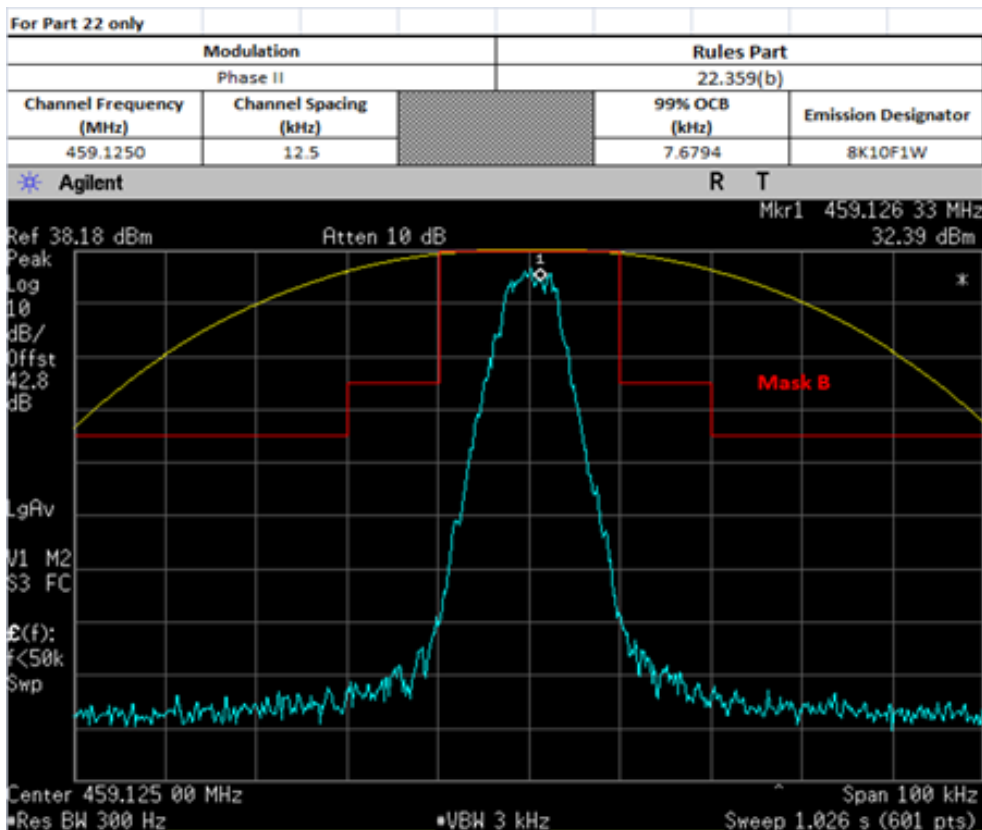

**6.5.5. Test Limit**

The 99% occupied bandwidth is the width of a frequency band such that, below the lower and above the upper frequency limits, the mean powers emitted are each equal to a specified percentage 0.5% of the total mean transmitted power.

## 6.6. Band Edge Conducted Spurious Emission (Part 22)

### 6.6.1. Test Setup (Analog)

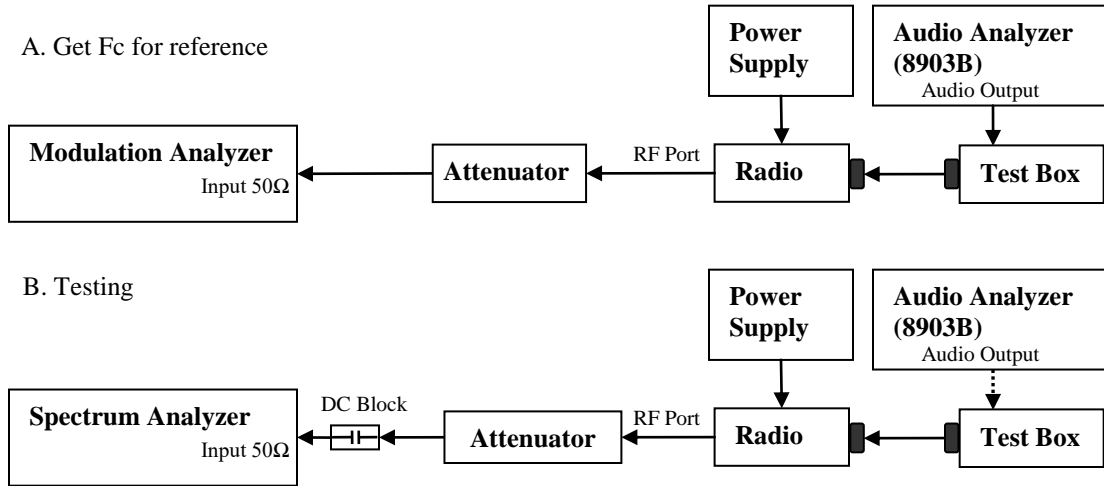

- 1) The DUT transmitter output port was connected to Modulation Analyzer.
- 2) Set the audio bandwidth filter to 15 kHz low pass filter and 50 kHz high pass filter.
- 3) Transmit the radio and set the audio analyzer to 2.5 kHz audio frequency and 50% of the rated deviation. Up the amplitude by 16 dB. Dekey the DUT.
- 4) Path loss for the measurement included.
- 5) Select the Occupied Bandwidth measurement for 99% and 26dB Emissions Bandwidth Measurement.
- 6) Key in the Fc and Resolution Bandwidth.
- 7) Transmit the DUT and record the occupied Bandwidth frequencies.
- 8) Preset the spectrum analyzer for band edge measurement.
- 9) The band edges of lowest and highest channels were measured.
- 10) Key in the Lowest and highest channel frequency, span is 60 kHz and Resolution Bandwidth is at least 1% of Emission Bandwidth.
- 11) Save the screen shot as modulated signal.
- 12) Remove the audio tone from audio analyzer to capture unmodulated signal.

\*Note:

- For emission designator ending with F3E, 16K0F3E is the worst case and therefore only 16K0F3E will be shown.

### 6.6.2. Test Result (Analog)

#### Max Power

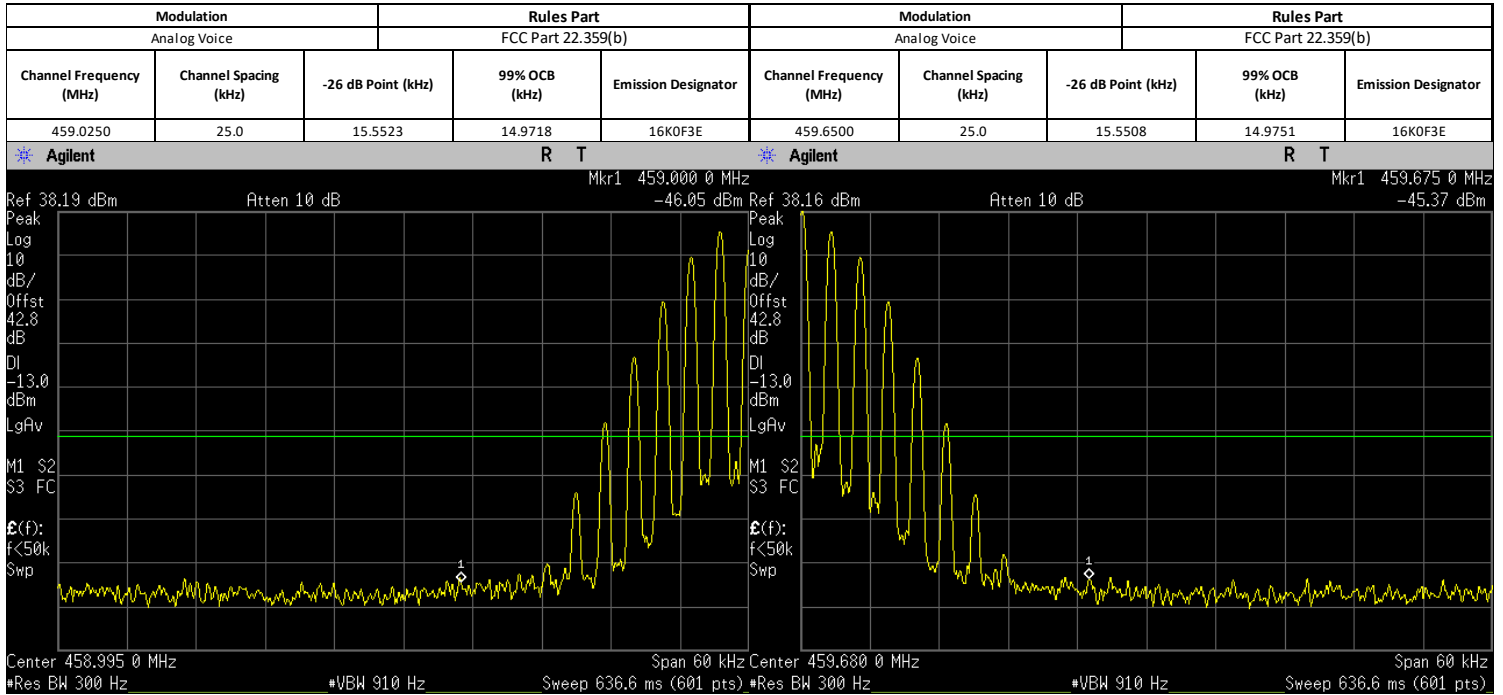

#### Max Power

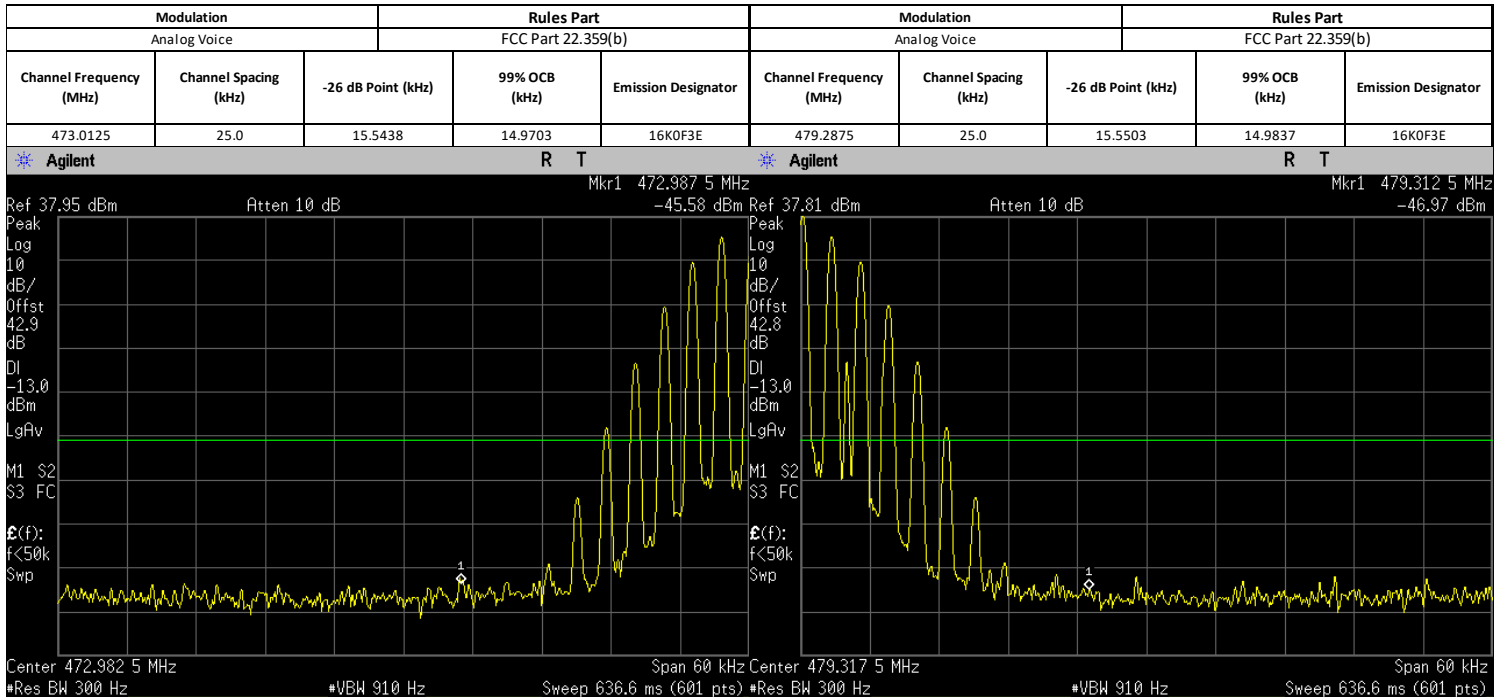

### 6.6.3. Test Setup (Digital)

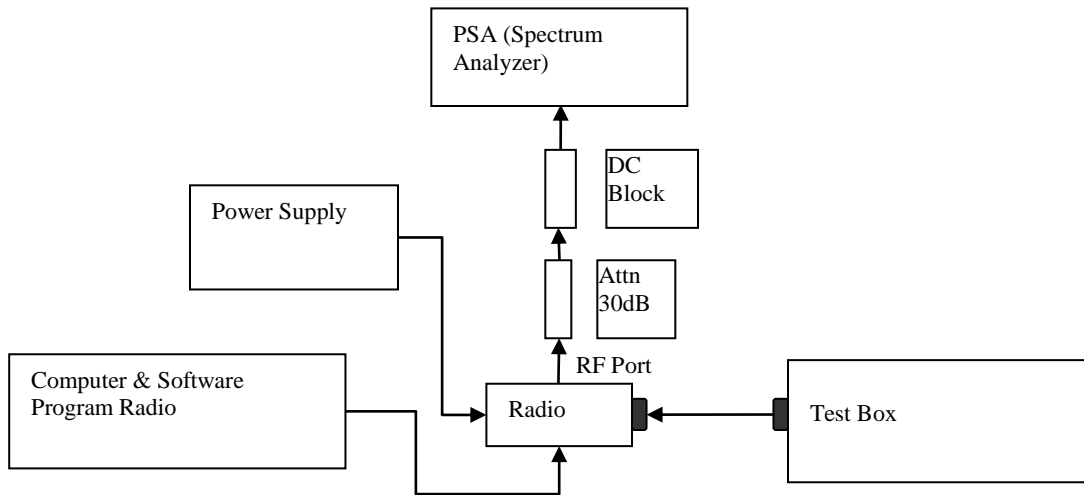

- 1) Program and set radio to operate in desire test frequency and digital mode with modulation. (\*4FSK, C4FM or other digital modulation form).
- 2) Path loss for the measurement included.
- 3) Select the Occupied Bandwidth measurement for 99% and 26dB Emissions Bandwidth Measurement.
- 4) Key in the Fc and Resolution Bandwidth.
- 5) Transmit radio record the occupied Bandwidth frequencies.
- 6) Preset the spectrum analyzer for band edge measurement.
- 7) Key in the lowest and highest channels frequency, span is 60 kHz and Resolution Bandwidth is at least 1% of Emission Bandwidth.
- 8) Save the screen shot.

\*Note:

- For Digital Modulation, 12.5 kHz Data F1D & FXD would be the same. Therefore only measurements with F1D modulation shown below.
- For Digital Modulation, 12.5 kHz Data F1E & FXE would be the same. Therefore only measurements with F1E modulation shown below.

### 6.6.4. Test Result (Digital)

#### Max Power

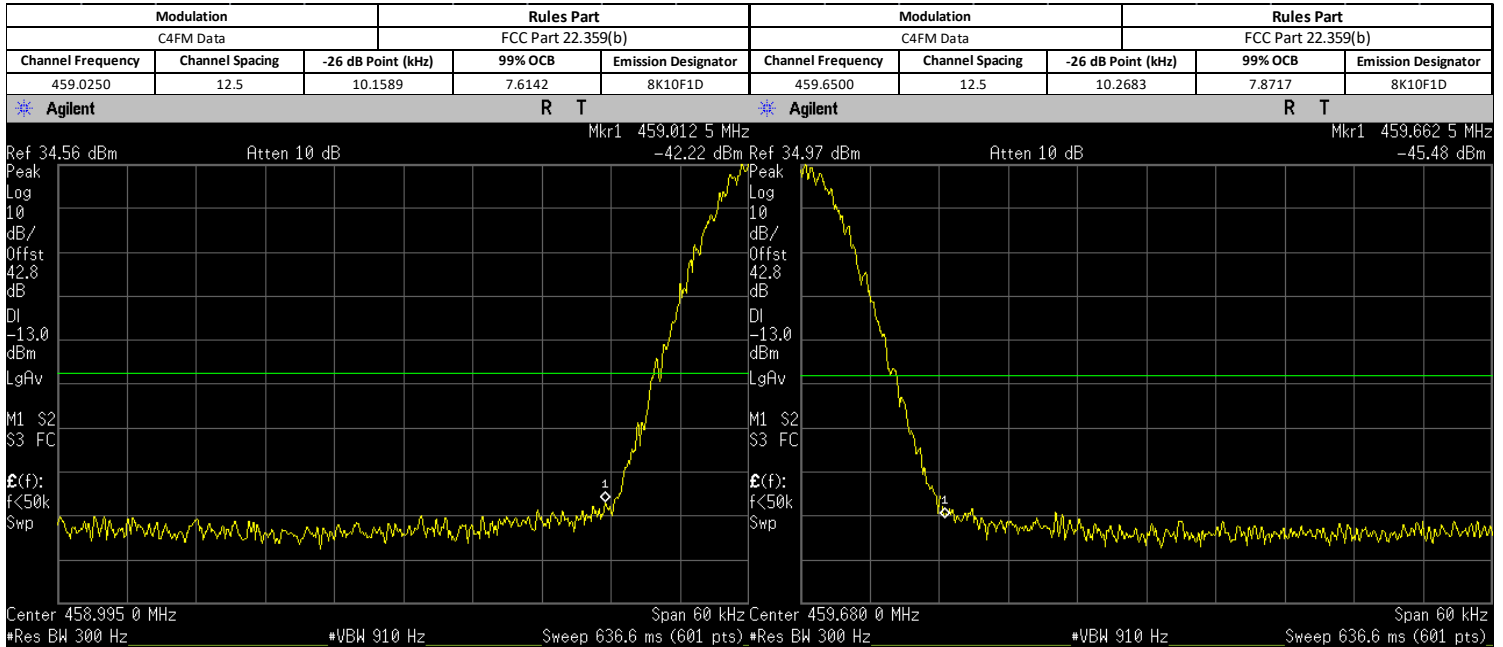

#### Max Power

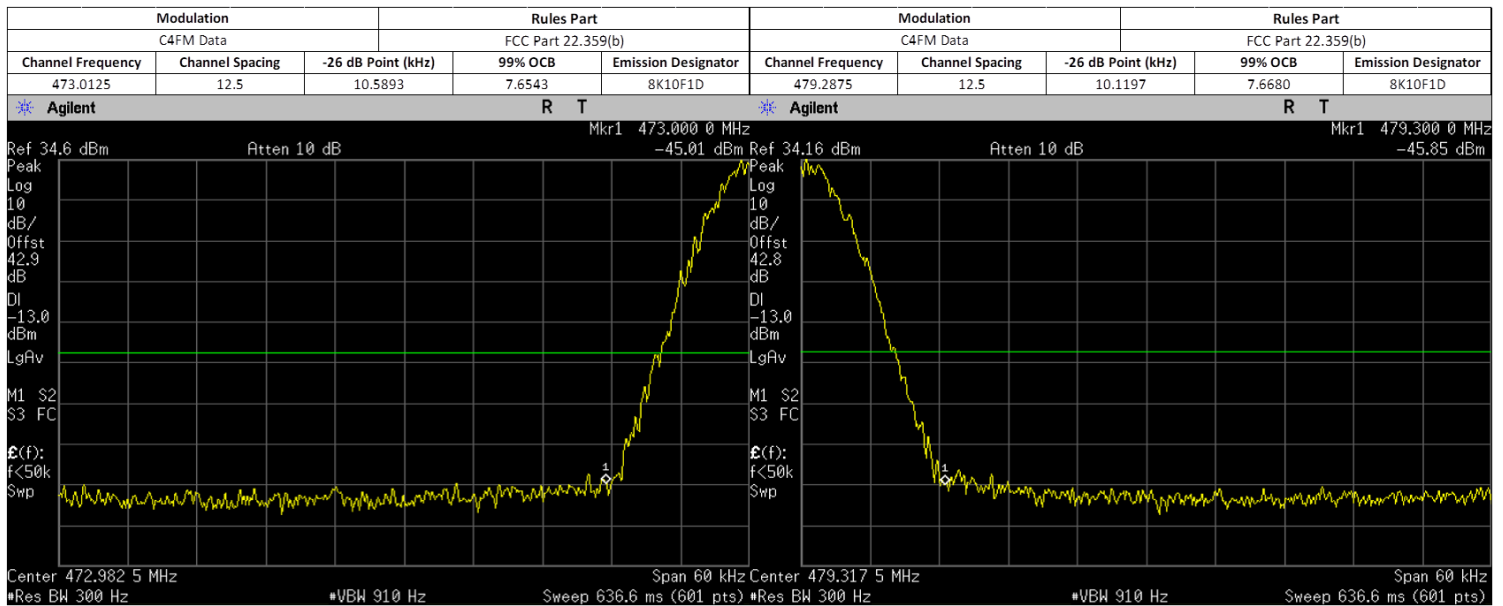

Phase II: Max Power

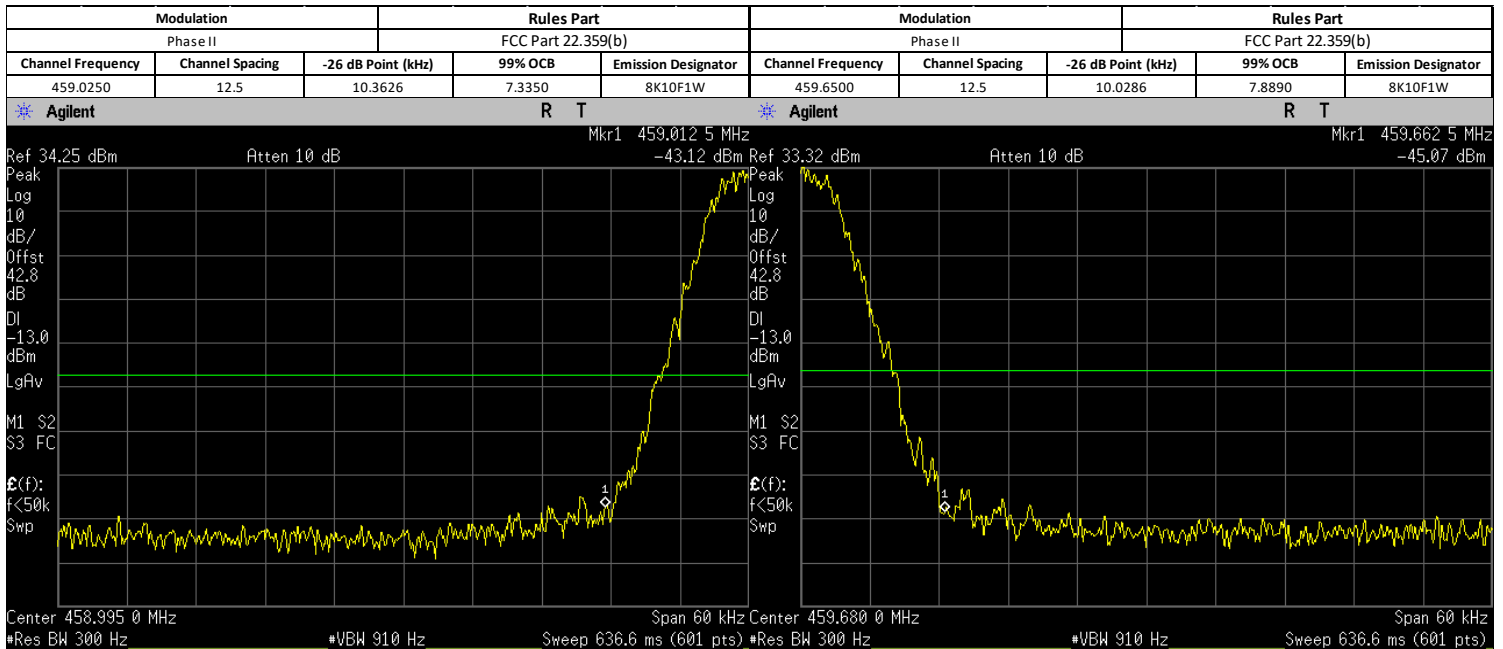

Phase II: Max Power

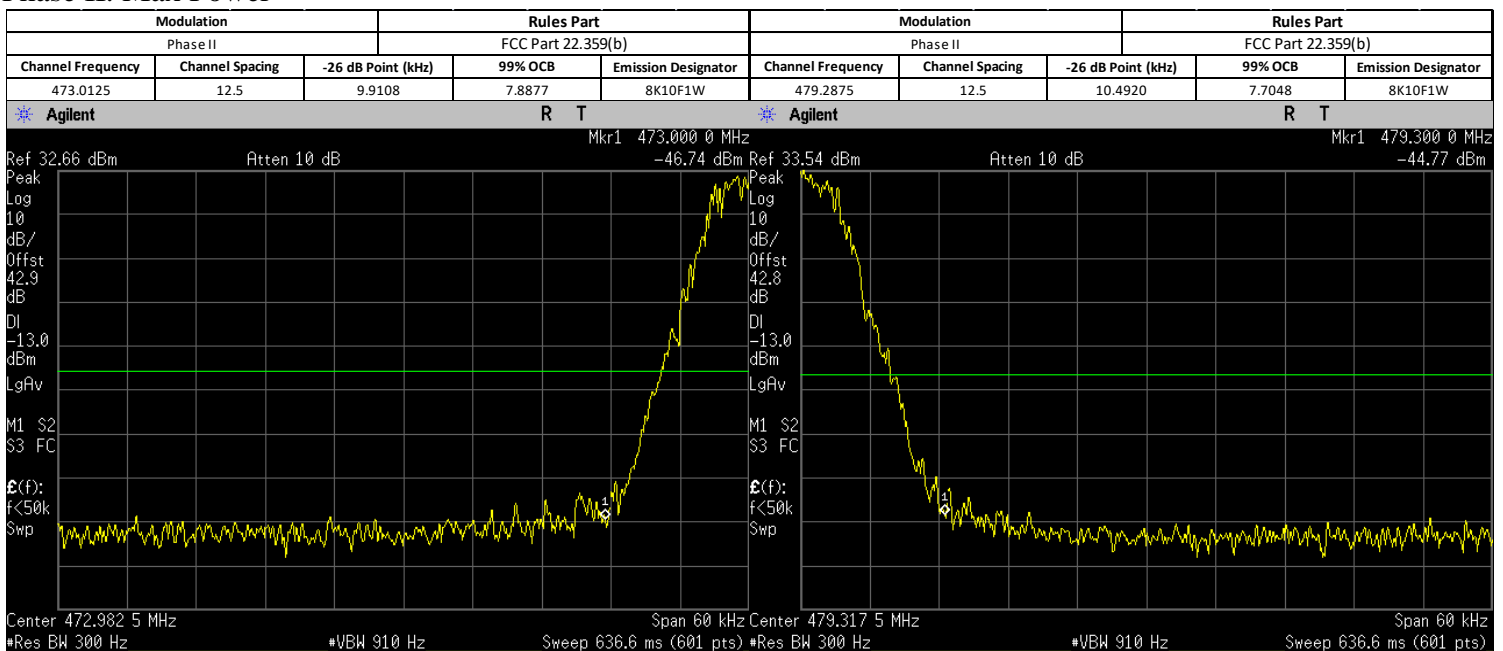

6.6.5. Test Limit

The power of any emission outside of the authorized operating frequency ranges must be attenuated below the transmitting power (P) by a factor of at least 43 + 10 log(P) dB.

## 6.7. Transient Frequency Behavior

### 6.7.1. Test Setup

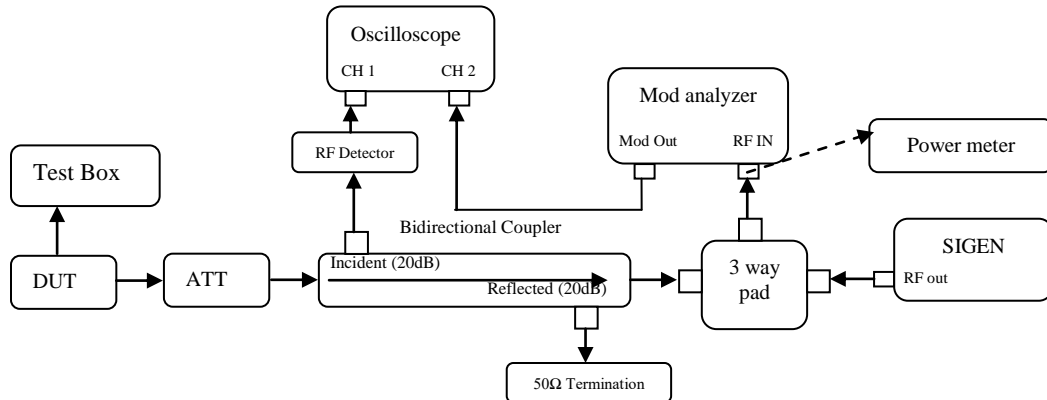

- 1) Connect the setup as figure above.
- 2) Path loss for the measurement included.
- 3) Set on Siggen with the assigned center frequency, internal 1 kHz FM tone.  
FM Deviation: Analog 25kHz Channel Spacing = 25 kHz  
Analog 12.5 kHz Channel Spacing = 12.5 kHz  
C4FM = 12.5 kHz
- 4) Turn on 50 kHz high pass filter and 15 kHz low pass filter on modulation analyzer.
- 5) Supply sufficient attenuation ATT to provide the output power of  $\leq -11\text{dBm}$  into power meter when DUT is keying up.
- 6) Note the power level on power meter and dekey the DUT.
- 7) Adjust the amplitude of the signal generator to the level power meter, maintained the amplitude throughout the rest of the measurement.
- 8) Connect the output to modulation analyzer.
- 9) Reduce 30dB attenuation and transmit the radio to get the trigger line.
- 10) Capture the screen shot for key-up (rising edge) and de-key (falling edge) mode.



### 6.7.2. Test Result

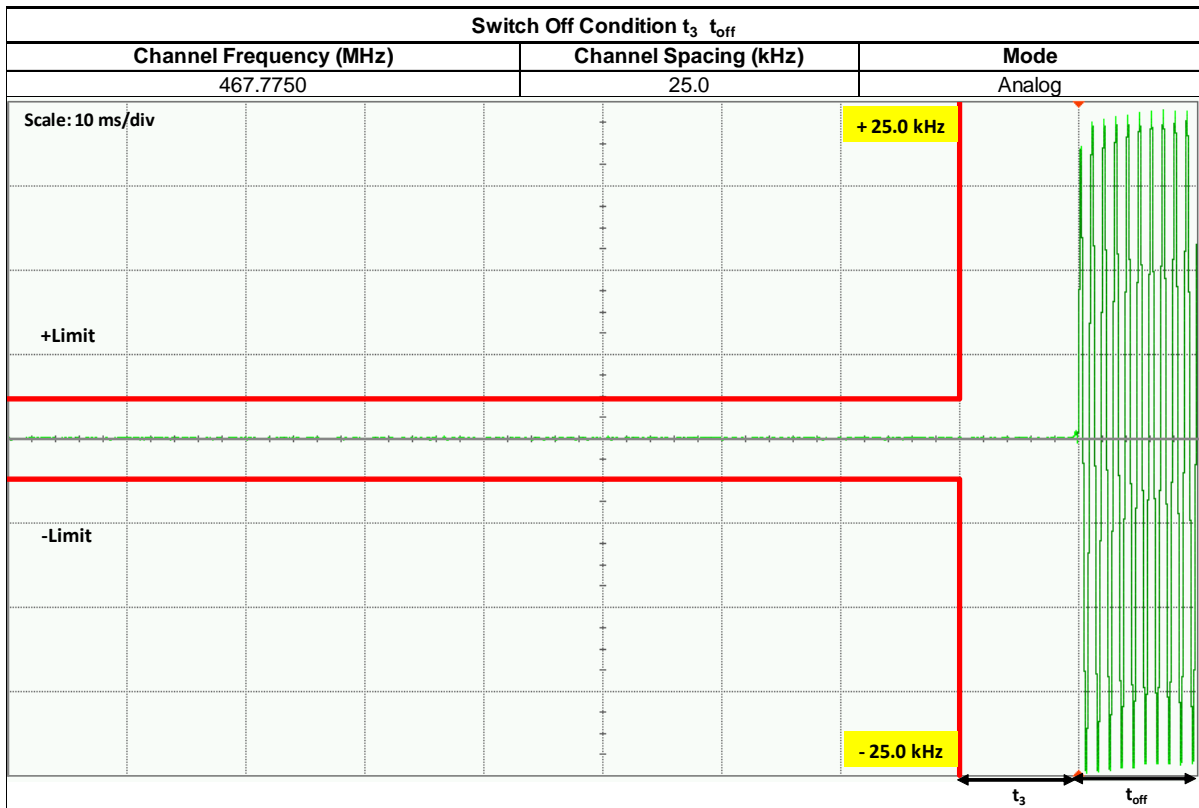
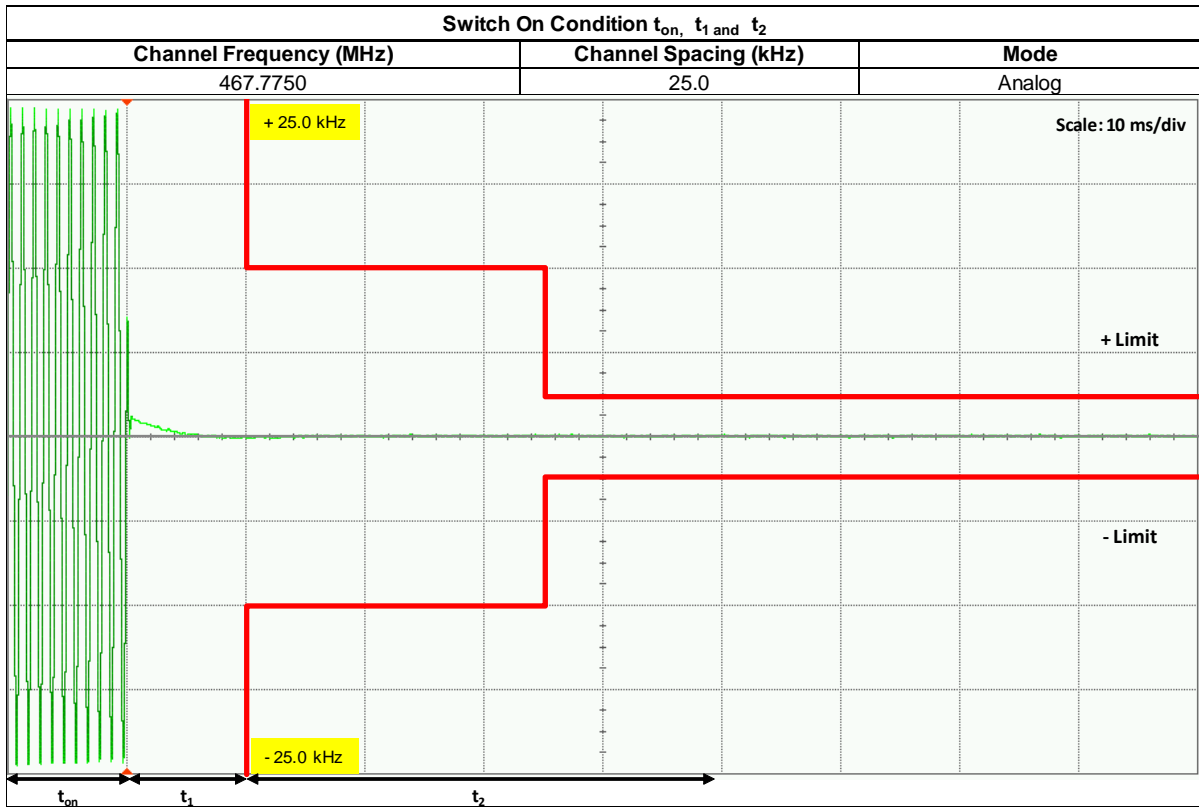

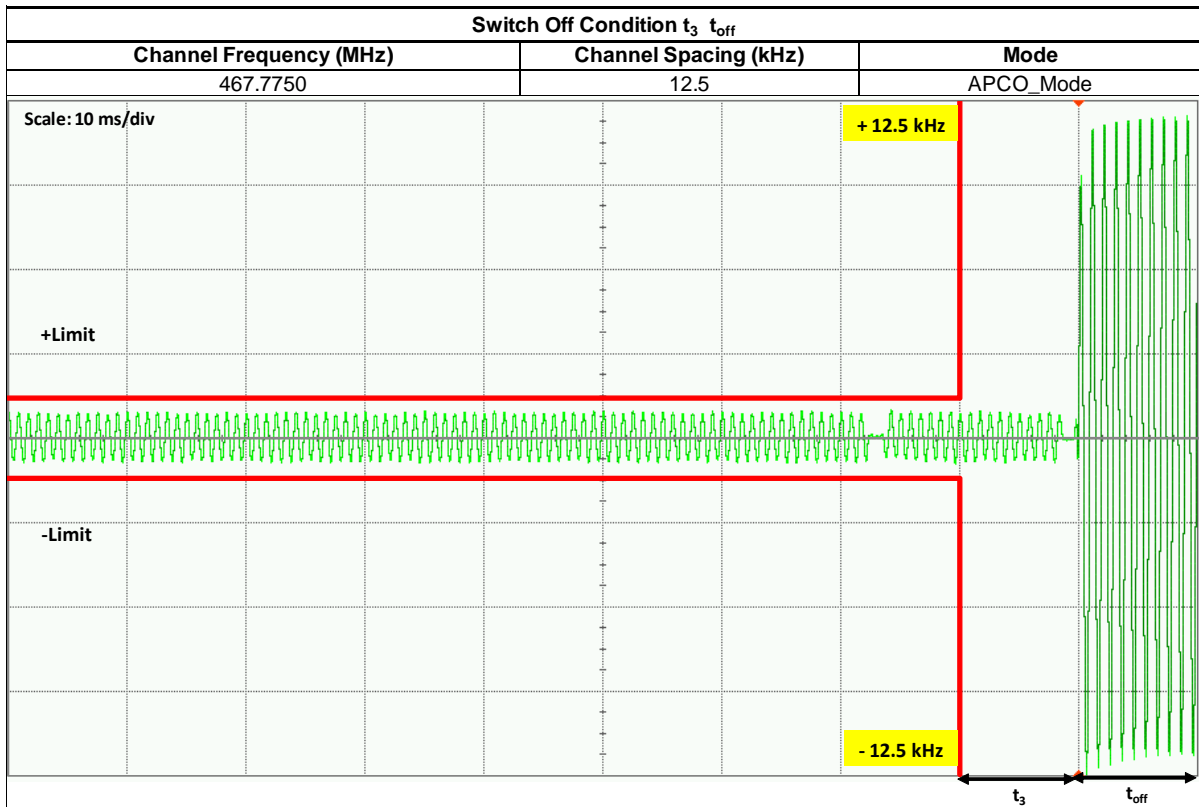
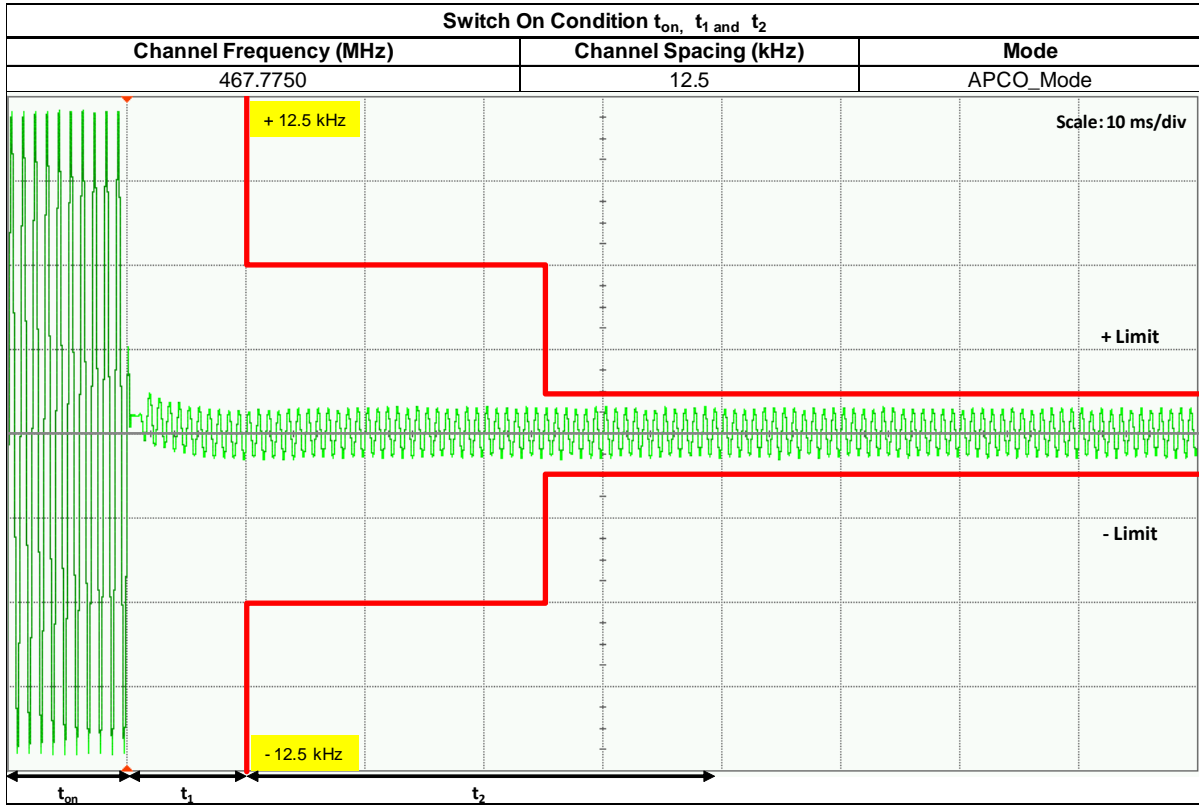

### 6.7.3. Test Limit

Transmitters designed to operate in the 150-174 MHz and 421-512 MHz frequency bands must maintain transient frequencies within the maximum frequency difference limits during the time intervals indicated:

Time intervals <sup>1 2</sup>	Maximum frequency difference <sup>3</sup>	All equipment	
		150 to 174 MHz	421 to 512 MHz
Transient Frequency Behavior for Equipment Designed to Operate on 25 kHz Channels			
$t_1^4$	±25.0 kHz	5.0 ms	10.0 ms
$t_2$	±12.5 kHz	20.0 ms	25.0 ms
$t_3^4$	±25.0 kHz	5.0 ms	10.0 ms
Transient Frequency Behavior for Equipment Designed to Operate on 12.5 kHz Channels			
$t_1^4$	±12.5 kHz	5.0 ms	10.0 ms
$t_2$	±6.25 kHz	20.0 ms	25.0 ms
$t_3^4$	±12.5 kHz	5.0 ms	10.0 ms
Transient Frequency Behavior for Equipment Designed to Operate on 6.25 kHz Channels			
$t_1^4$	±6.25 kHz	5.0 ms	10.0 ms
$t_2$	±3.125 kHz	20.0 ms	25.0 ms
$t_3^4$	±6.25 kHz	5.0 ms	10.0 ms

<sup>1</sup>  $t_{on}$  is the instant when a 1 kHz test signal is completely suppressed, including any capture time due to phasing.

$t_1$  is the time period immediately following  $t_{on}$ .

$t_2$  is the time period immediately following  $t_1$ .

$t_3$  is the time period from the instant when the transmitter is turned off until  $t_{off}$ .

$t_{off}$  is the instant when the 1 kHz test signal starts to rise.

<sup>2</sup> During the time from the end of  $t_2$  to the beginning of  $t_3$ , the frequency difference must not exceed the limits specified in §90.213.

<sup>3</sup> Difference between the actual transmitter frequency and the assigned transmitter frequency.

<sup>4</sup> If the transmitter carrier output power rating is 6 watts or less, the frequency difference during this time period may exceed the maximum frequency difference for this time period.

## 6.8. Adjacent Channel Power

### 6.8.1. Test Setup (Analog)

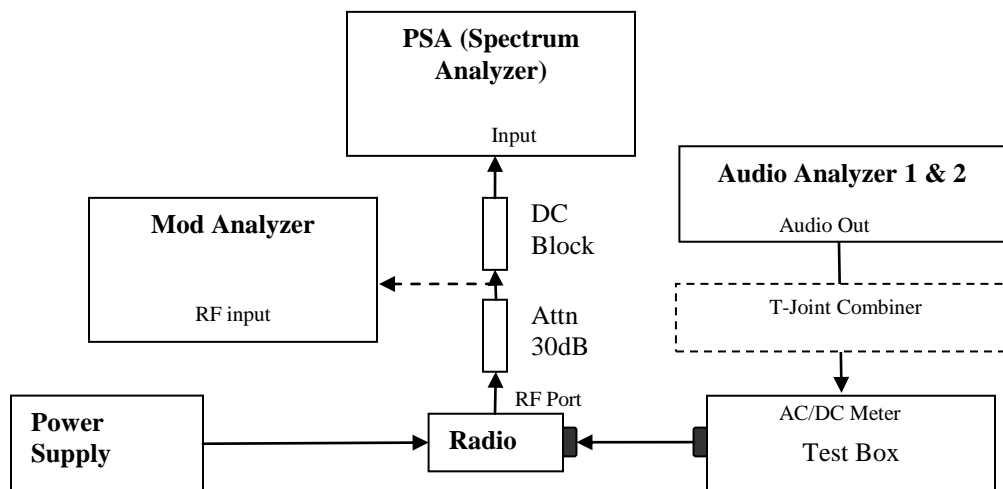

- 1) The DUT transmitter output port was connected to modulation analyzer.
- 2) Transmit the radio and turn on 1<sup>st</sup> audio analyzer with audio frequency 650Hz, 50% rated deviation, and record the amplitude value as AmpT1.
- 3) Turn off Audio analyzer 1 and turn on audio analyzer 2, set the audio frequency to 2.2 kHz and 50% deviation. Record the amplitude as AmpT2.
- 4) Turn both audio analyzers ON and up 10dB amplitude level.
- 5) Connect the output to PSA and set to assigned center frequency.
- 6) Set Span, Resolution Bandwidth and Video Bandwidth per rules part.
- 7) Transmit the radio and record the Adjacent Channel Power value in dBc.

### 6.8.2. Test Result **Not Applicable**

### 6.8.3. Test Setup (Digital)

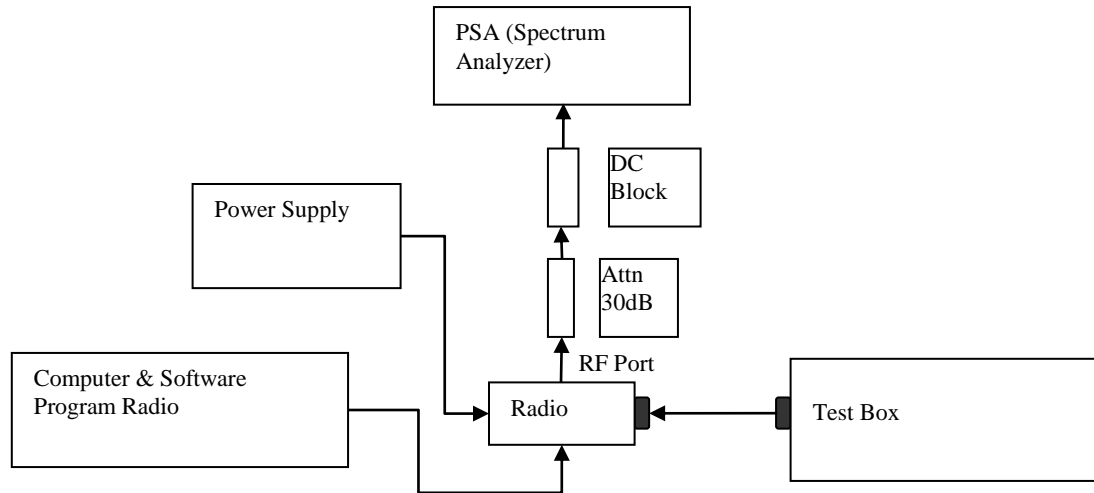

- 1) Program and set radio to operate in desire test frequency and digital mode with modulation. (4FSK, C4FM or other digital modulation form).
- 2) Prepare setup as per picture.
- 3) Turn on the ACP Measurement – Press Measure, ACP.
- 4) Set Span, Resolution Bandwidth and Video Bandwidth as per rules part.
- 5) Transmit the radio and record the Adjacent Channel Power value in dBc.

### 6.8.4. Test Result **Not Applicable**

### 6.8.5. Test Limit

#### 12.5 kHz MOBILE TRANSMITTER ACP REQUIREMENTS

Offset from center frequency (kHz)	Measurement bandwidth (kHz)	Maximum ACP relative (dBc)
9.375	6.25	-40
15.625	6.25	-60
21.875	6.25	-60
37.50	25.00	-60
62.50	25.00	-65
87.50	25.00	-65
150.00	100	-65
250.00	100	-65
350.00	100	-65
>400 to 12 MHz	30 (s)	-75
12 MHz to paired receive band	30 (s)	-75
In the paired receive band	30 (s)	-100

#### 25 kHz MOBILE TRANSMITTER ACP REQUIREMENTS

Offset from center frequency (kHz)	Measurement bandwidth (kHz)	Maximum ACP relative (dBc)
15.625	6.25	-40
21.875	6.25	-60
37.50	25	-60
62.50	25	-65
87.50	25	-65
150.00	100	-65
250.00	100	-65
350.00	100	-65
>400 kHz to 12 MHz	30 (s)	-75
12 MHz to paired receive band	30 (s)	-75
In the paired receive band	30 (s)	-100

**12.5 kHz BASE TRANSMITTER ACP REQUIREMENTS**

Offset from center frequency (kHz)	Measurement bandwidth (kHz)	Maximum ACP (dBc)
9.375	6.25	-40
15.625	6.25	-60
21.875	6.25	-60
37.5	25	-60
62.5	25	-65
87.5	25	-65
150	100	-65
250	100	-65
350.00	100	-65
>400 kHz to 12 MHz	30 (s)	-80
12 MHz to paired receive band	30 (s)	-80
In the paired receive band	30 (s)	<sup>1</sup> -85

**25 kHz BASE TRANSMITTER ACP REQUIREMENTS**

Offset from center frequency (kHz)	Measurement bandwidth (kHz)	Maximum ACP (dBc)
15.625	6.25	-40
21.875	6.25	-60
37.5	25	-60
62.5	25	-65
87.5	25	-65
150	100	-65
250	100	-65
350	100.00	-65
>400 kHz to 12 MHz	30 (s)	-80
12 MHz to paired receive band	30 (s)	-80
In the paired receive band	30 (s)	<sup>1</sup> -85

## 6.9. Conducted Spurious Emission

### 6.9.1. Test Setup

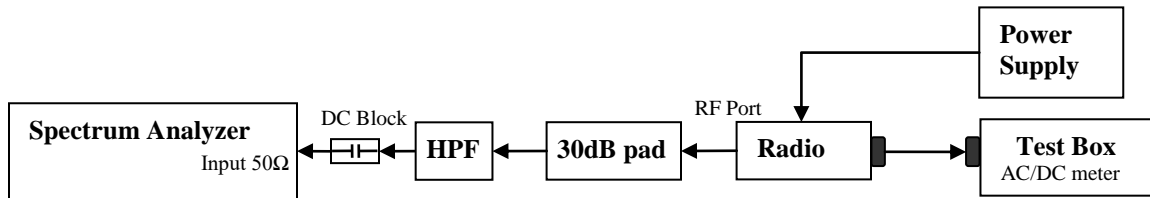

- 1) The DUT transmitter output port was connected to Spectrum Analyzer with above setup.
- 2) Program and set radio to operate in desire test frequency and mode. (Analog / digital modulation form).
- 3) Path loss for the measurement included.
- 4) Set the PSA Resolution Bandwidth as per rules part.
- 5) Set the Ref offset from the pathloss offset calibration file.
- 6) Adjust the center frequency of the spectrum analyzer for incremental coverage of the range from:
  - a. 9 KHz to  $F_c - \text{Test Bandwidth}$
  - b.  $F_c + \text{Test Bandwidth}$  to  $2F_c - 5\text{MHz}$ .
- 7) Key up the DUT, Peak Search the highest Spur and record the levels of spurious emissions
- 8) Dekey the DUT.
- 9) Turn On High Pass Filter path and Key up the DUT.
- 10) Adjust the PSA Freq for incremental coverage of range from  $2F_c$  to  $10F_c$
- 11) Key up the DUT and record the highest spur levels of spurious emissions.



**6.9.2. Test Result (Analog)**

**Analog: 380.0125 MHz, 25.kHz Channel Spacing, Max. Power**

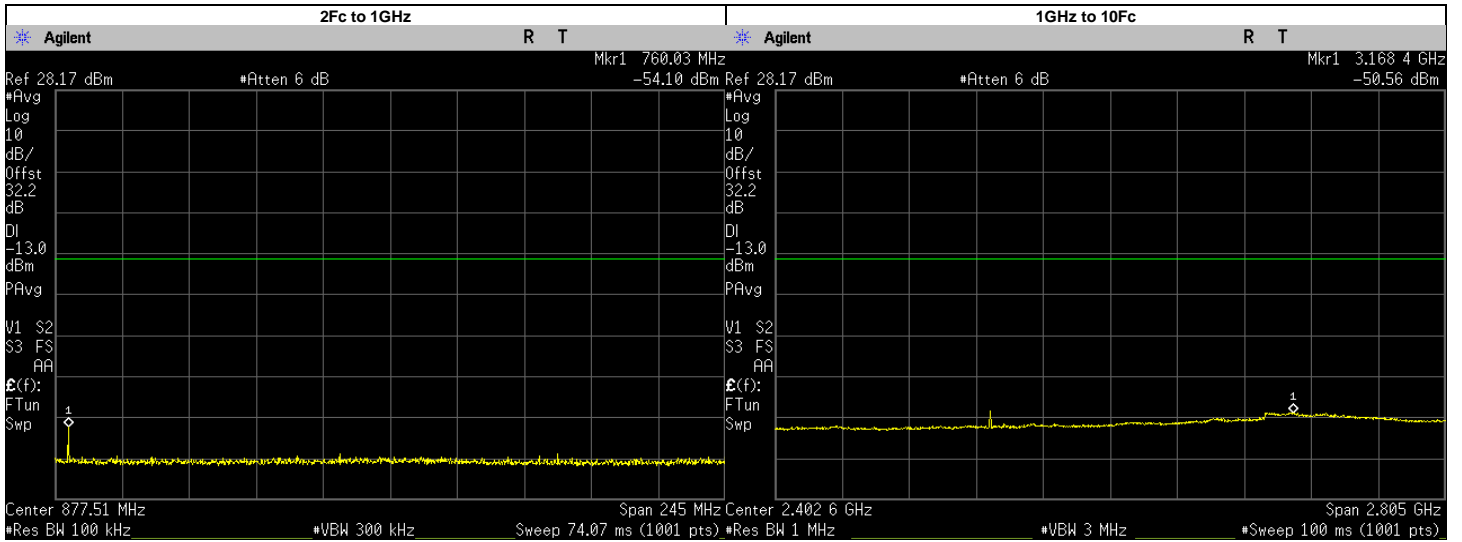
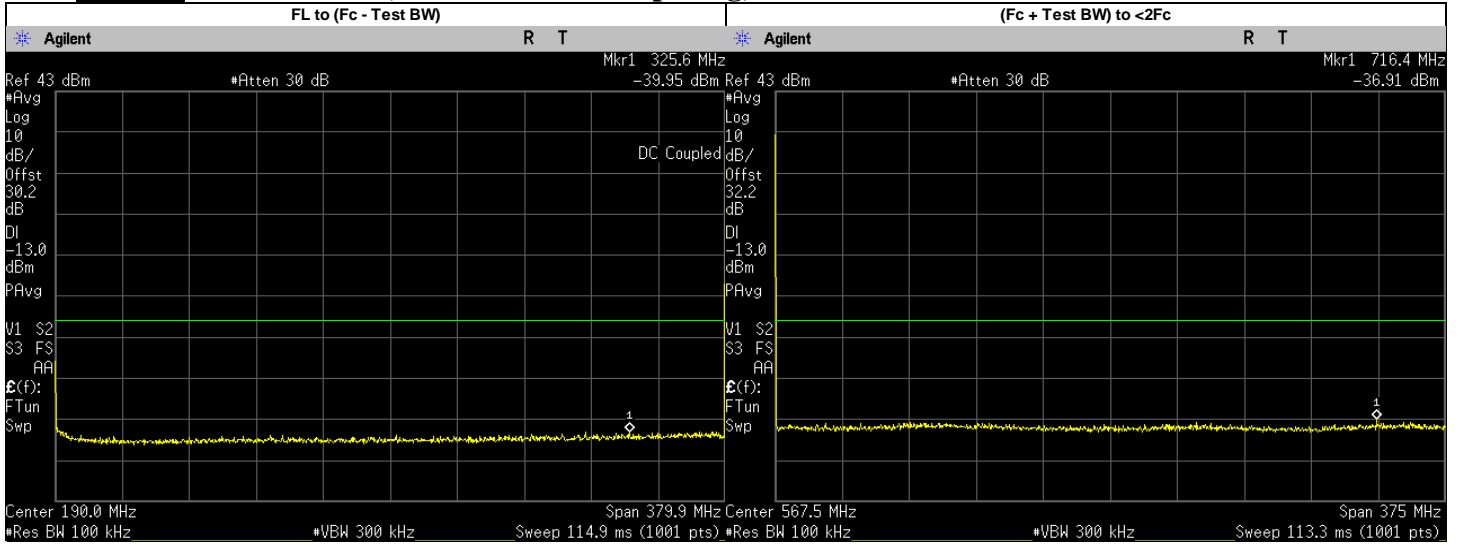

Frequency Range	Highest Spur Frequency (MHz)	Spurious Level (dBm)	Failing Limit (dBm)	Results
FL to (Fc - Test BW)	325.6000	-39.9510	-13.00	PASS
(Fc + Test BW) to <2Fc	716.4044	-36.9100	-13.00	PASS
2Fc to 1GHz 1GHz to 10Fc	760.0250	-54.1000	-13.00	PASS
	3168.3620	-50.5600	-13.00	PASS
	1140.0370	-54.4274	-13.00	PASS
	1520.0500	-54.6164	-13.00	PASS
	1900.0620	-50.6699	-13.00	PASS
	2280.0750	-53.9068	-13.00	PASS
	2660.0880	-53.3286	-13.00	PASS
	3040.1000	-51.8782	-13.00	PASS
	3420.1130	-51.5363	-13.00	PASS
	3800.1250	-52.5951	-13.00	PASS

**Analog: 406.2 MHz, 25.kHz Channel Spacing, Max. Power**

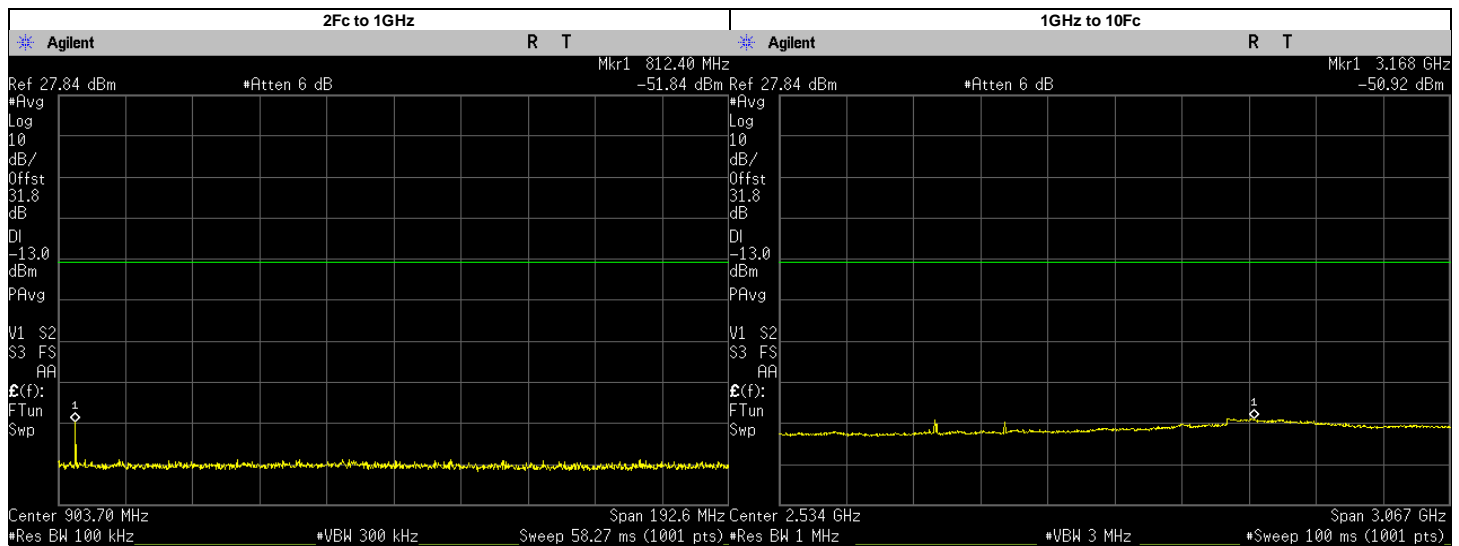
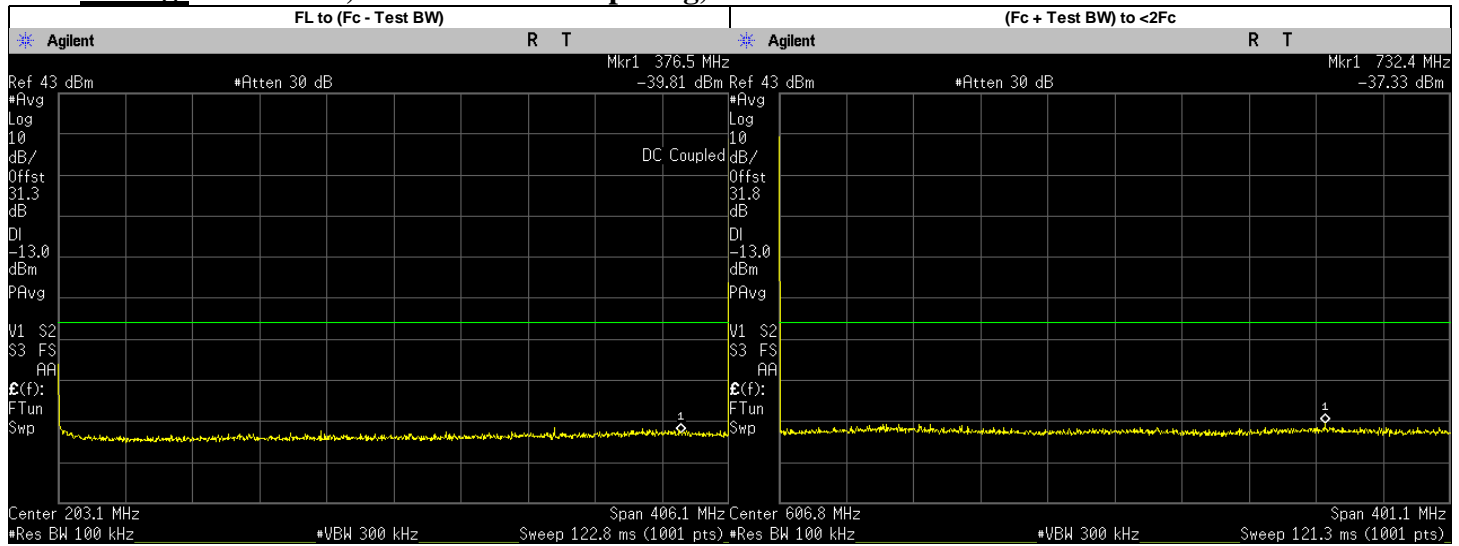

Frequency Range	Highest Spur Frequency (MHz)	Spurious Level (dBm)	Failing Limit (dBm)	Results
FL to (Fc - Test BW)	376.5000	-39.8100	-13.00	PASS
(Fc + Test BW) to <2Fc	732.3860	-37.3300	-13.00	PASS
2Fc to 1GHz 1GHz to 10Fc	812.4000	-51.8410	-13.00	PASS
	3168.3690	-50.9200	-13.00	PASS
	1218.6000	-54.4935	-13.00	PASS
	1624.8000	-54.5021	-13.00	PASS
	2031.0000	-52.1210	-13.00	PASS
	2437.2000	-53.8107	-13.00	PASS
	2843.4000	-52.2380	-13.00	PASS
	3249.6000	-51.7437	-13.00	PASS
	3655.8000	-52.9729	-13.00	PASS
4062.0000	-52.9988	-13.00	PASS	

### Analog: 450.025 MHz, 25.kHz Channel Spacing, Max. Power

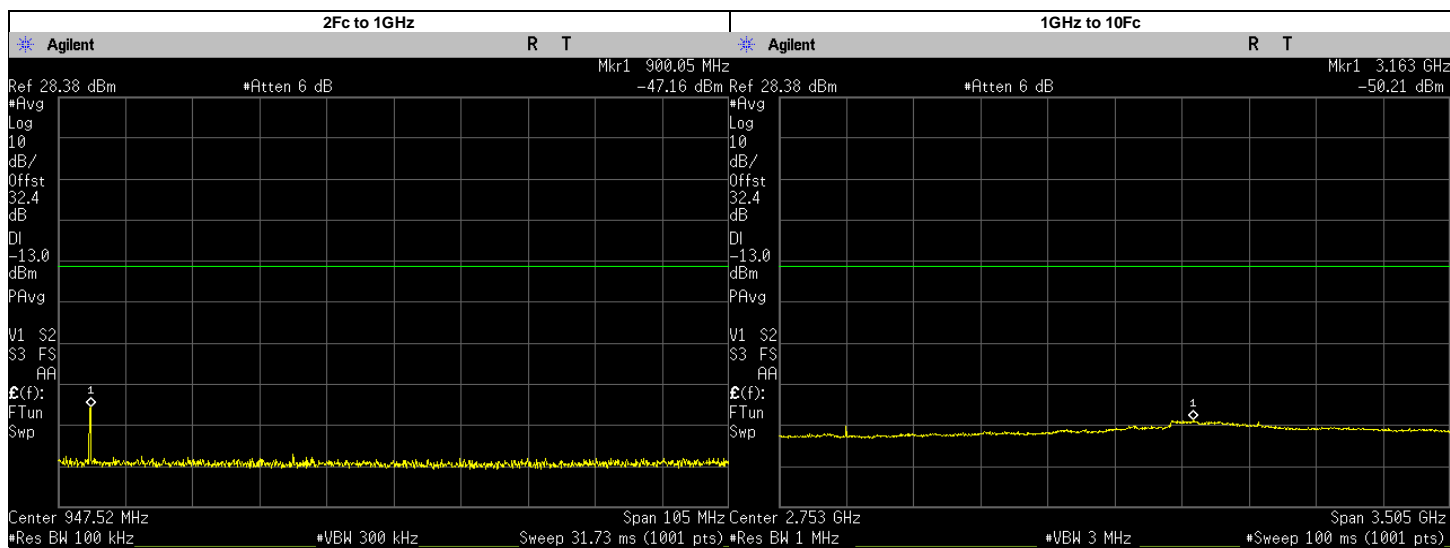
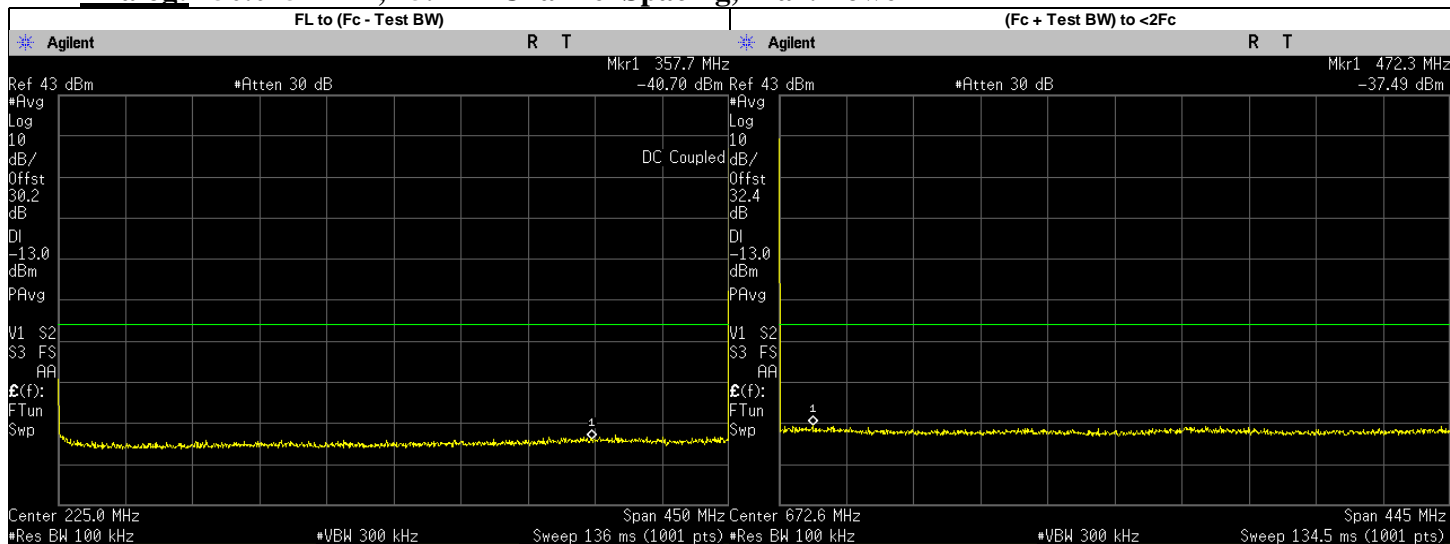

Frequency Range	Highest Spur Frequency (MHz)	Spurious Level (dBm)	Failing Limit (dBm)	Results
FL to (Fc - Test BW)	357.7000	-40.7020	-13.00	PASS
(Fc + Test BW) to <2Fc	472.3302	-37.4900	-13.00	PASS
2Fc to 1GHz 1GHz to 10Fc	900.0500	-47.1601	-13.00	PASS
	3162.7390	-50.2100	-13.00	PASS
	1350.0750	-51.9786	-13.00	PASS
	1800.1000	-53.6284	-13.00	PASS
	2250.1250	-53.2626	-13.00	PASS
	2700.1500	-53.0738	-13.00	PASS
	3150.1750	-50.8138	-13.00	PASS
	3600.2000	-52.0447	-13.00	PASS
	4050.2250	-52.4647	-13.00	PASS
4500.2500	-53.1831	-13.00	PASS	

**Analog: 450.025 MHz, 25.kHz Channel Spacing, Low. Power**

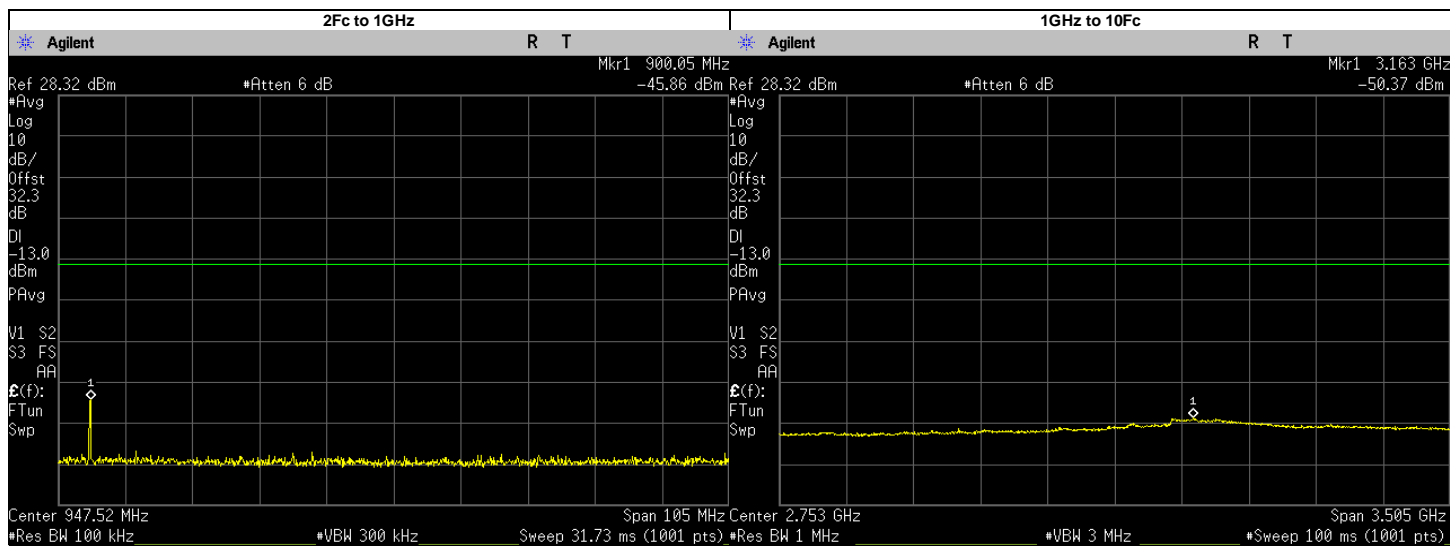
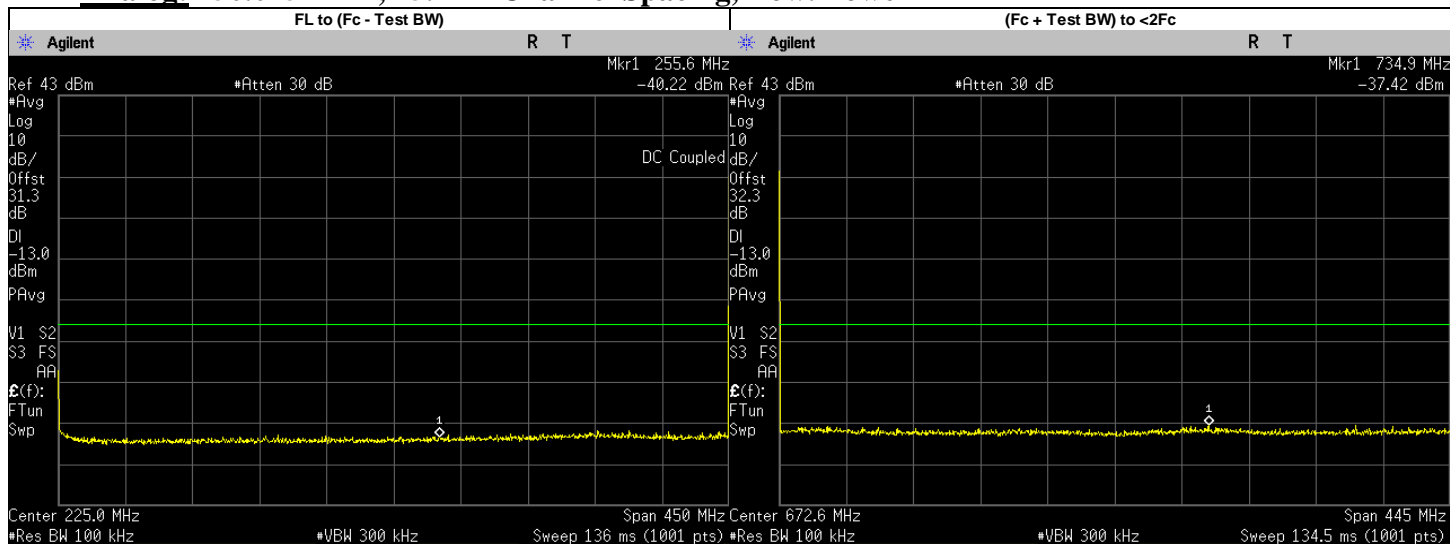

Frequency Range	Highest Spur Frequency (MHz)	Spurious Level (dBm)	Failing Limit (dBm)	Results
FL to (Fc - Test BW)	255.6000	-40.2230	-13.00	PASS
(Fc + Test BW) to <2Fc	734.8614	-37.4200	-13.00	PASS
2Fc to 1GHz 1GHz to 10Fc	900.0500	-45.8559	-13.00	PASS
	3162.7390	-50.3700	-13.00	PASS
	1350.0750	-54.2970	-13.00	PASS
	1800.1000	-53.5875	-13.00	PASS
	2250.1250	-53.5313	-13.00	PASS
	2700.1500	-53.1701	-13.00	PASS
	3150.1750	-50.8070	-13.00	PASS
	3600.2000	-52.3022	-13.00	PASS
	4050.2250	-52.6473	-13.00	PASS
4500.2500	-53.2511	-13.00	PASS	

**Analog: 459.125 MHz, 25.kHz Channel Spacing, Max. Power**

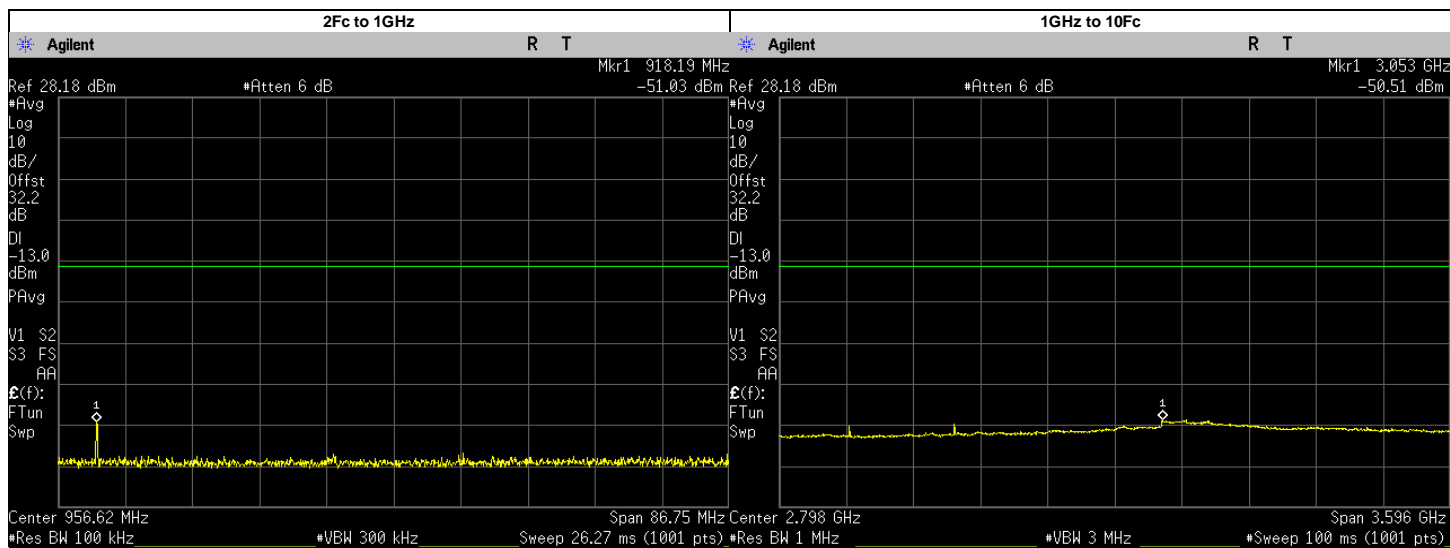
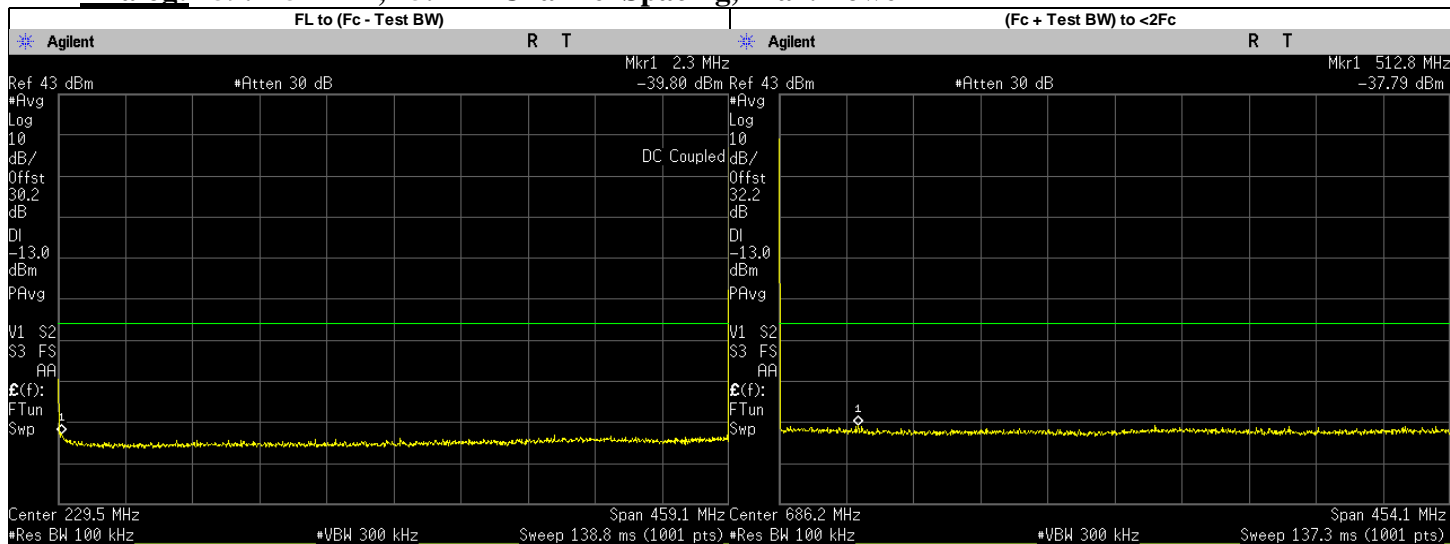

Frequency Range	Highest Spur Frequency (MHz)	Spurious Level (dBm)	Failing Limit (dBm)	Results
FL to (Fc - Test BW)	2.3000	-39.8010	-13.00	PASS
(Fc + Test BW) to <2Fc	512.7618	-37.7900	-13.00	PASS
2Fc to 1GHz 1GHz to 10Fc	918.1947	-51.0300	-13.00	PASS
	3053.4590	-50.5100	-13.00	PASS
	1377.3750	-52.1105	-13.00	PASS
	1836.5000	-54.0435	-13.00	PASS
	2295.6250	-53.4305	-13.00	PASS
	2754.7500	-52.5391	-13.00	PASS
	3213.8750	-51.2876	-13.00	PASS
	3673.0000	-52.6127	-13.00	PASS
	4132.1250	-52.8486	-13.00	PASS
4591.2500	-53.2060	-13.00	PASS	

**Analog: 467.775 MHz, 25.kHz Channel Spacing, Max. Power**

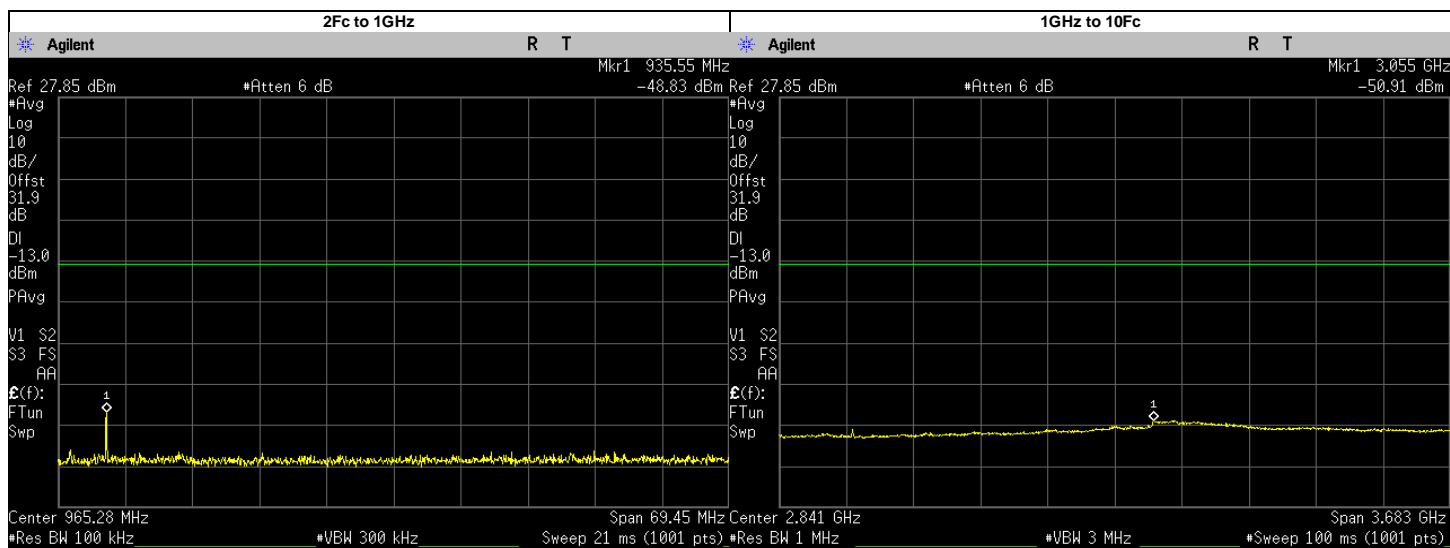
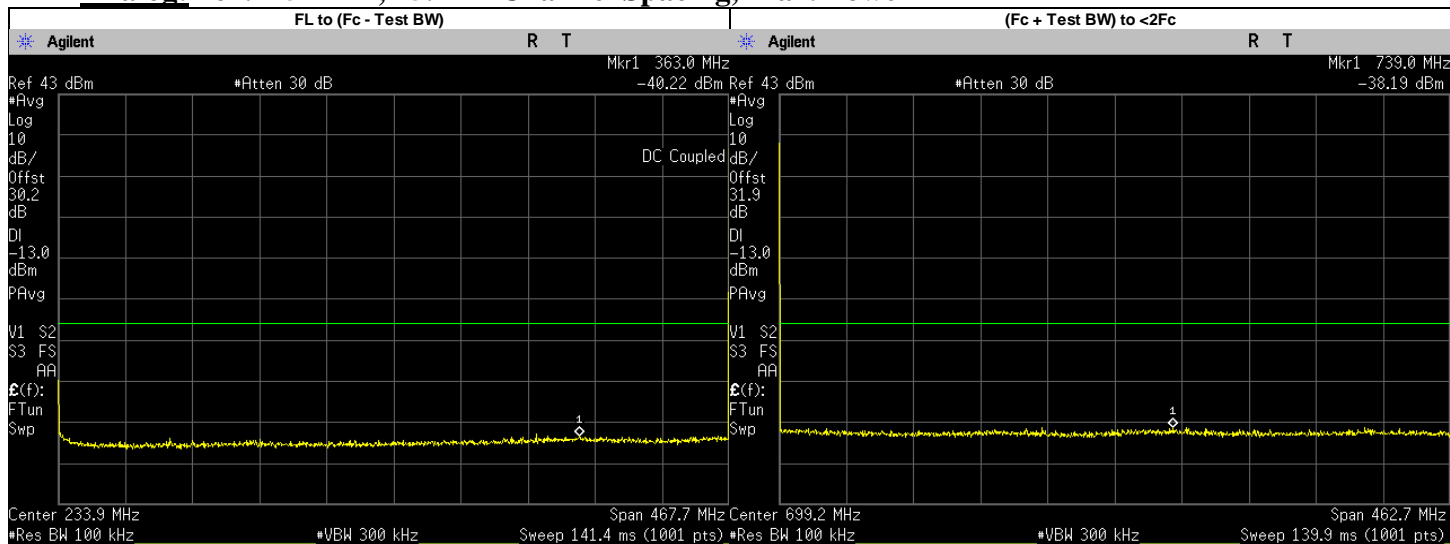

Frequency Range	Highest Spur Frequency (MHz)	Spurious Level (dBm)	Failing Limit (dBm)	Results
FL to (Fc - Test BW)	363.0000	-40.2180	-13.00	PASS
(Fc + Test BW) to <2Fc	738.9847	-38.1900	-13.00	PASS
2Fc to 1GHz 1GHz to 10Fc	935.5500	-48.8316	-13.00	PASS
	3054.9740	-50.9100	-13.00	PASS
	1403.3250	-53.3902	-13.00	PASS
	1871.1000	-54.4351	-13.00	PASS
	2338.8750	-53.7187	-13.00	PASS
	2806.6500	-53.1196	-13.00	PASS
	3274.4250	-51.3012	-13.00	PASS
	3742.2000	-53.0278	-13.00	PASS
	4209.9750	-53.3404	-13.00	PASS
4677.7500	-53.3584	-13.00	PASS	

**Analog: 467.775 MHz, 25.kHz Channel Spacing, Low. Power**

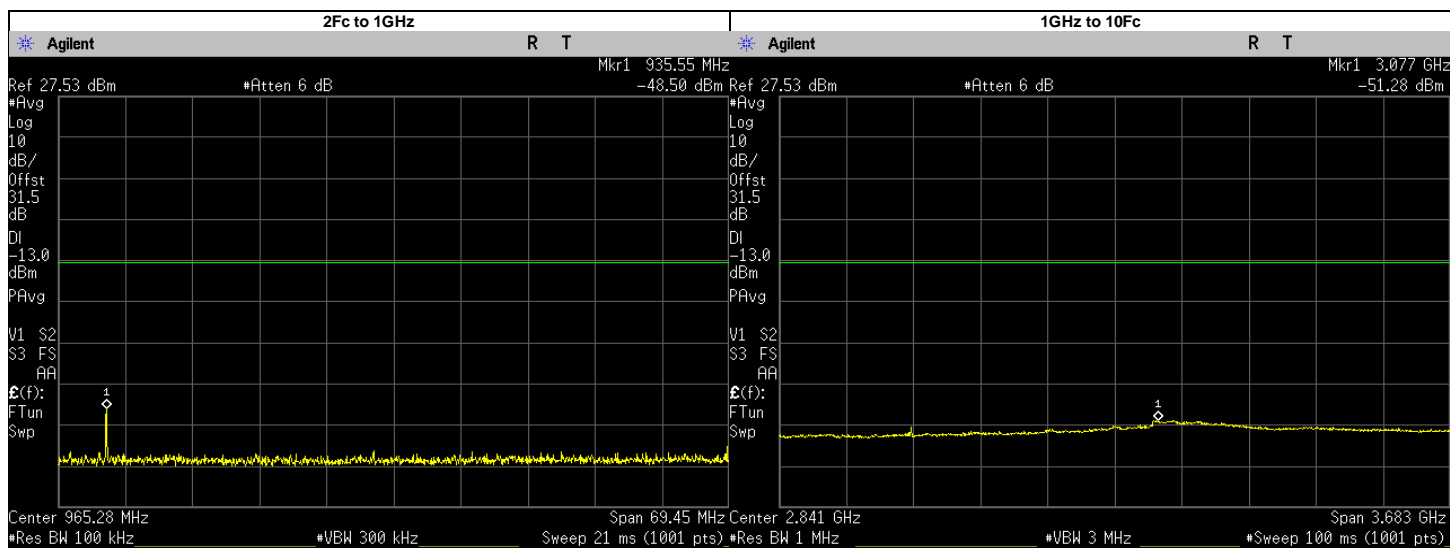
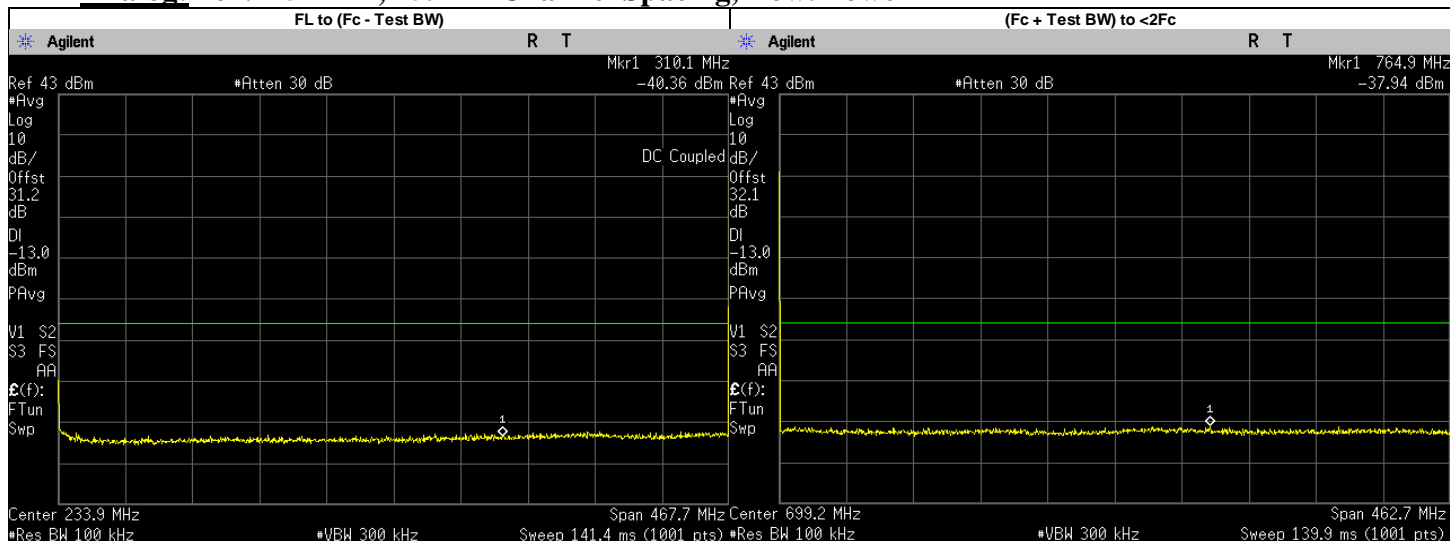

Frequency Range	Highest Spur Frequency (MHz)	Spurious Level (dBm)	Failing Limit (dBm)	Results
FL to (Fc - Test BW)	310.1000	-40.3640	-13.00	PASS
(Fc + Test BW) to <2Fc	764.9000	-37.9400	-13.00	PASS
2Fc to 1GHz 1GHz to 10Fc	935.5500	-48.5029	-13.00	PASS
	3077.0710	-51.2800	-13.00	PASS
	1403.3250	-55.3623	-13.00	PASS
	1871.1000	-54.8817	-13.00	PASS
	2338.8750	-54.4574	-13.00	PASS
	2806.6500	-53.3239	-13.00	PASS
	3274.4250	-51.8246	-13.00	PASS
	3742.2000	-53.1947	-13.00	PASS
	4209.9750	-53.6860	-13.00	PASS
4677.7500	-53.7174	-13.00	PASS	

**Analog: 482.0125 MHz, 25.kHz Channel Spacing, Max. Power**

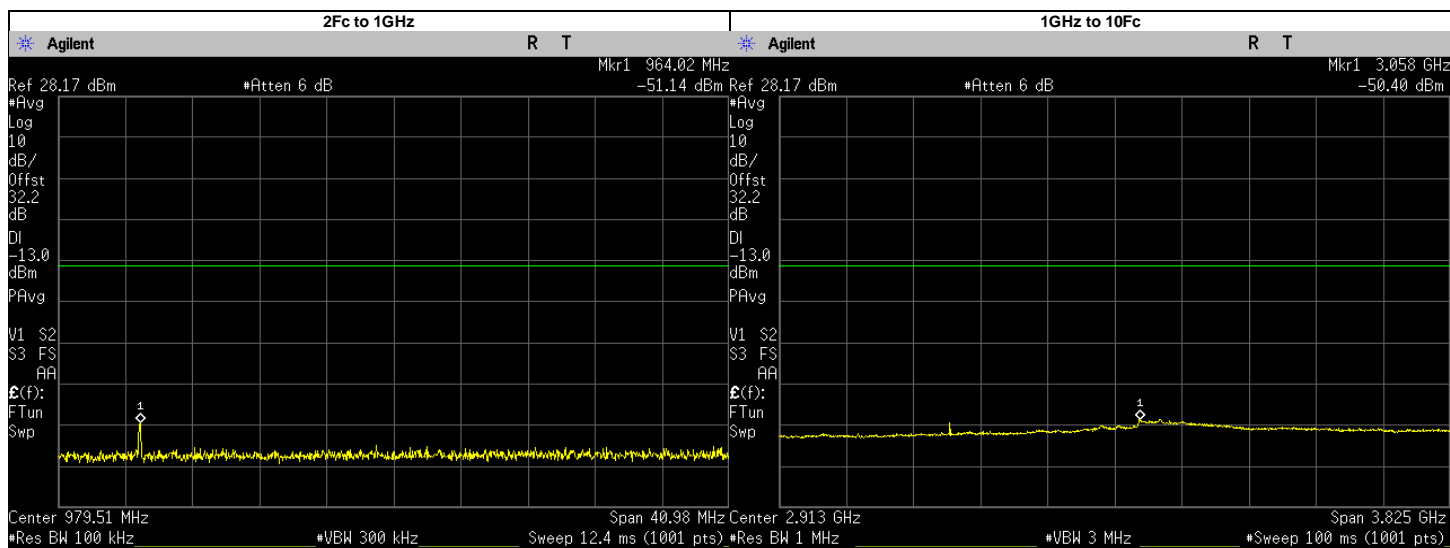
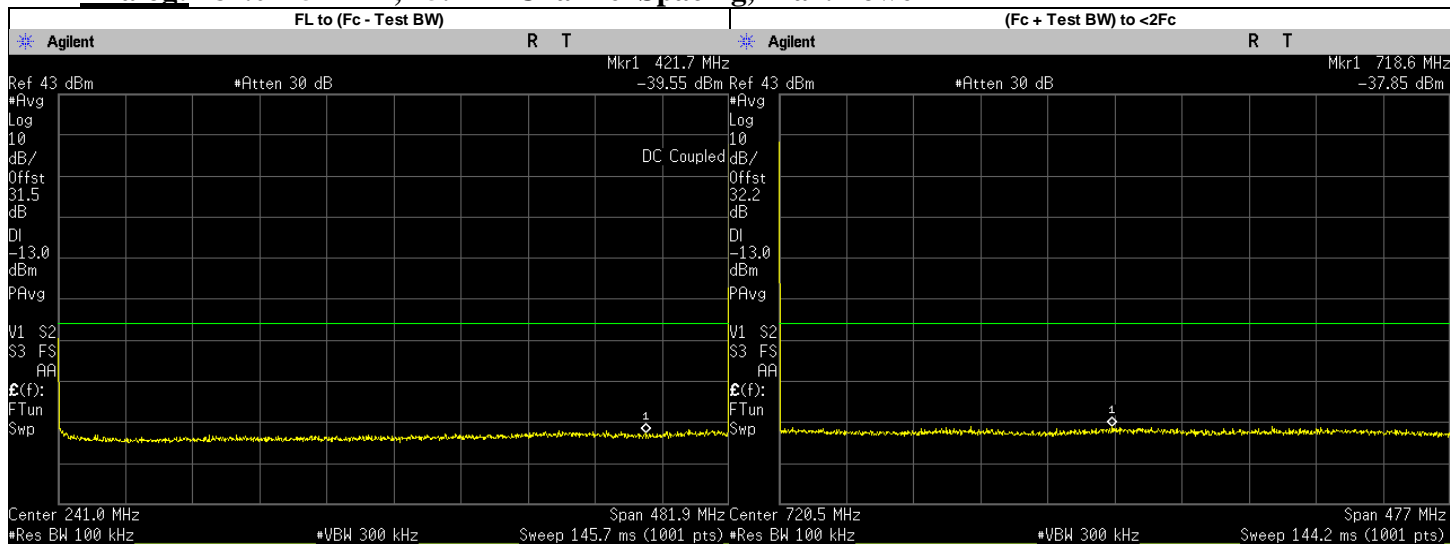

Frequency Range	Highest Spur Frequency (MHz)	Spurious Level (dBm)	Failing Limit (dBm)	Results
FL to (Fc - Test BW)	421.7000	-39.5460	-13.00	PASS
(Fc + Test BW) to <2Fc	718.6393	-37.8500	-13.00	PASS
2Fc to 1GHz 1GHz to 10Fc	964.0250	-51.1417	-13.00	PASS
	3057.9170	-50.4000	-13.00	PASS
	1446.0370	-53.9889	-13.00	PASS
	1928.0500	-53.8536	-13.00	PASS
	2410.0620	-53.3865	-13.00	PASS
	2892.0750	-52.8228	-13.00	PASS
	3374.0880	-51.6651	-13.00	PASS
	3856.1000	-52.4758	-13.00	PASS
	4338.1130	-53.1677	-13.00	PASS
	4820.1250	-53.1496	-13.00	PASS



**Analog: 511.9875 MHz, 25.kHz Channel Spacing, Max. Power**

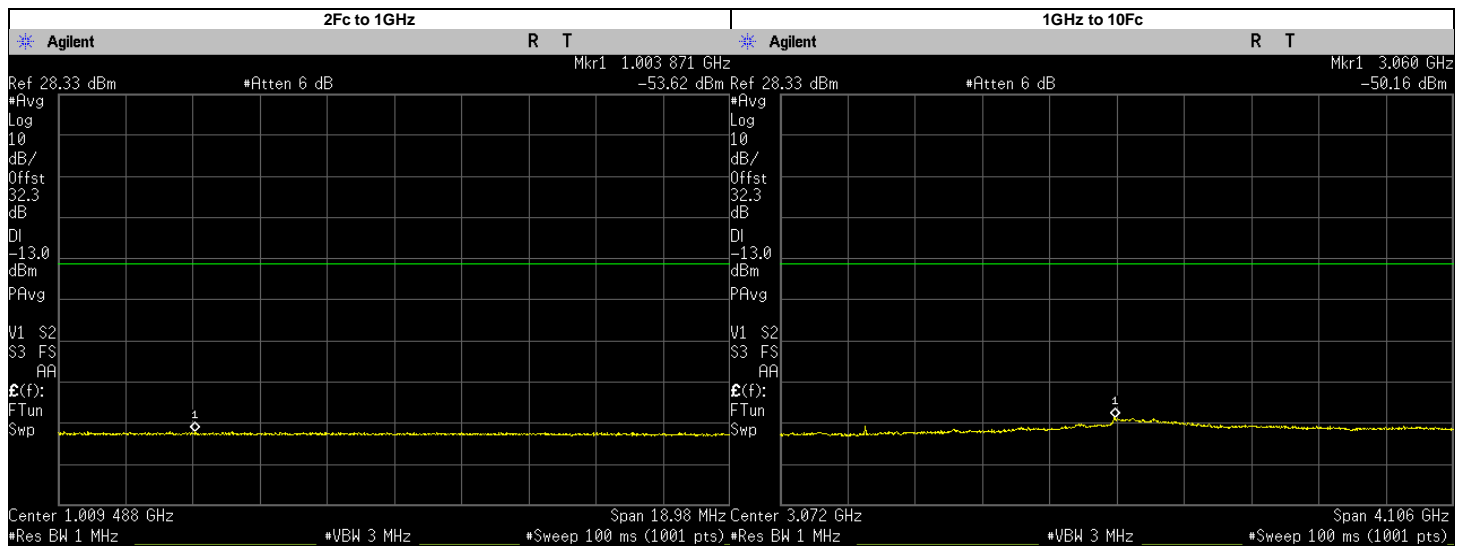
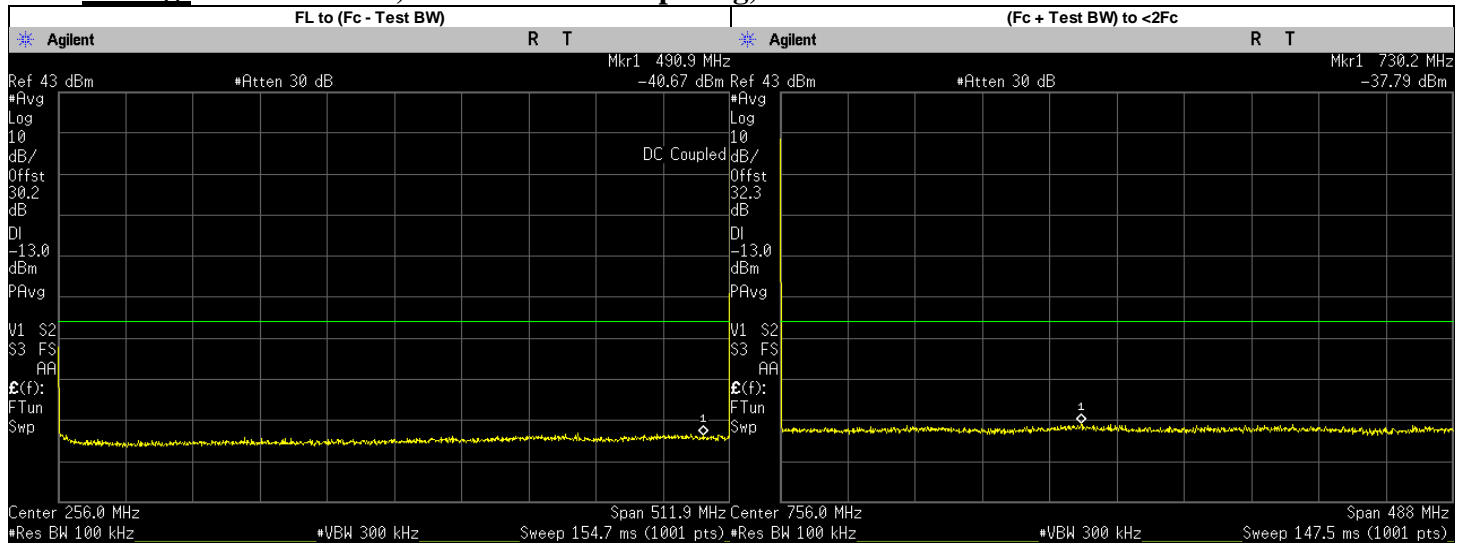

Frequency Range	Highest Spur Frequency (MHz)	Spurious Level (dBm)	Failing Limit (dBm)	Results
FL to (Fc - Test BW)	490.9000	-40.6710	-13.00	PASS
(Fc + Test BW) to <2Fc	730.1605	-37.7900	-13.00	PASS
2Fc to 1GHz 1GHz to 10Fc	1003.8710	-53.6200	-13.00	PASS
	3059.6070	-50.1600	-13.00	PASS
	1023.9750	-54.5054	-13.00	PASS
	1535.9630	-52.5702	-13.00	PASS
	2047.9500	-53.7478	-13.00	PASS
	2559.9370	-53.0840	-13.00	PASS
	3583.9120	-52.3379	-13.00	PASS
	4095.9000	-52.5913	-13.00	PASS
	4607.8870	-53.1894	-13.00	PASS
5119.8750	-53.1844	-13.00	PASS	

**Analog: 511.9875 MHz, 25.kHz Channel Spacing, Low. Power**

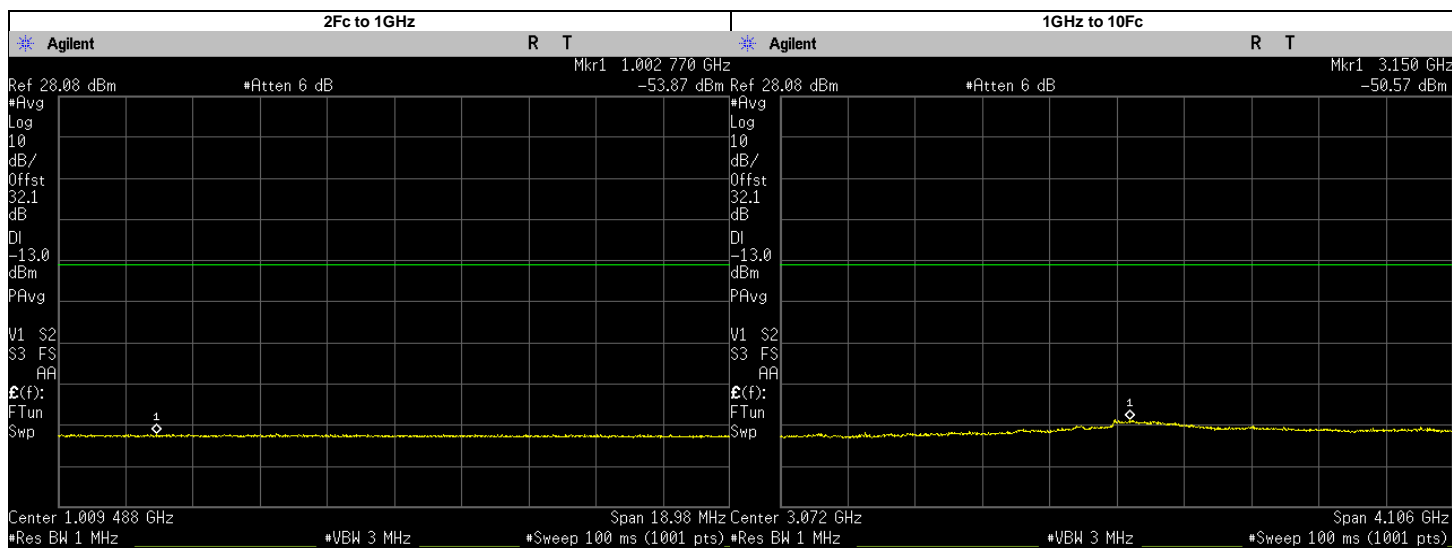
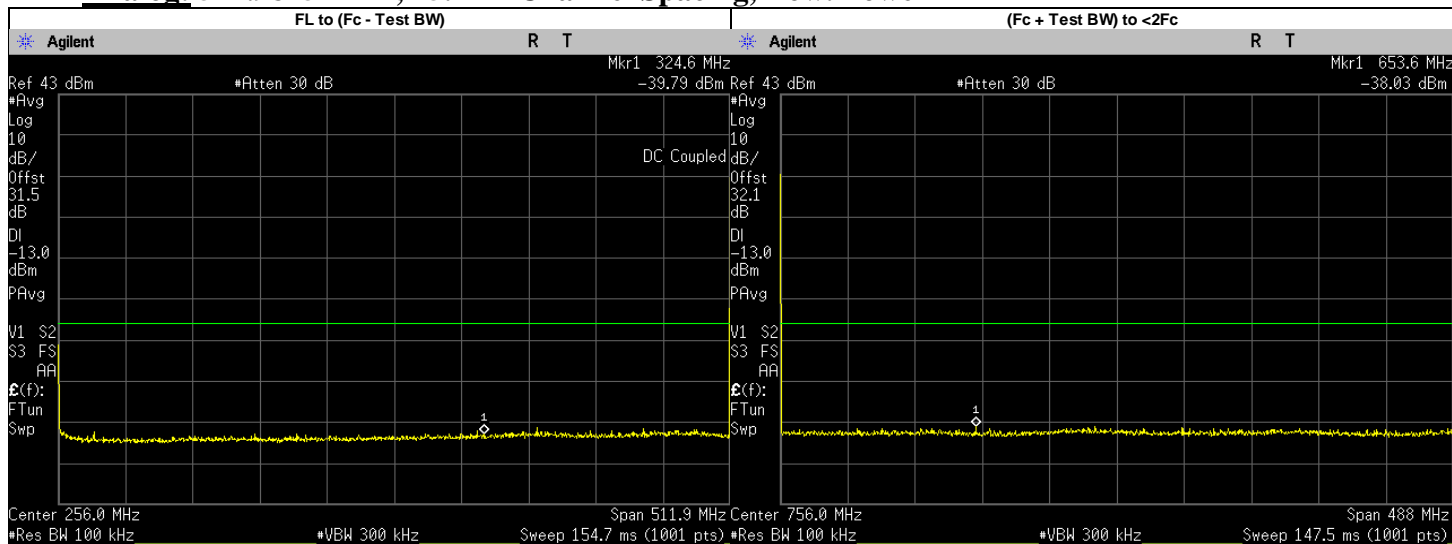

Frequency Range	Highest Spur Frequency (MHz)	Spurious Level (dBm)	Failing Limit (dBm)	Results
FL to (Fc - Test BW)	324.6000	-39.7880	-13.00	PASS
(Fc + Test BW) to <2Fc	653.5515	-38.0300	-13.00	PASS
2Fc to 1GHz 1GHz to 10Fc	1002.7700	-53.8700	-13.00	PASS
	3149.9370	-50.5700	-13.00	PASS
	1023.9750	-54.5586	-13.00	PASS
	1535.9630	-53.7420	-13.00	PASS
	2047.9500	-54.0032	-13.00	PASS
	2559.9370	-53.2221	-13.00	PASS
	3583.9120	-52.3994	-13.00	PASS
	4095.9000	-52.9509	-13.00	PASS
	4607.8870	-53.0832	-13.00	PASS
5119.8750	-53.3631	-13.00	PASS	

### Analog: 519.9875 MHz, 25.kHz Channel Spacing, Max. Power

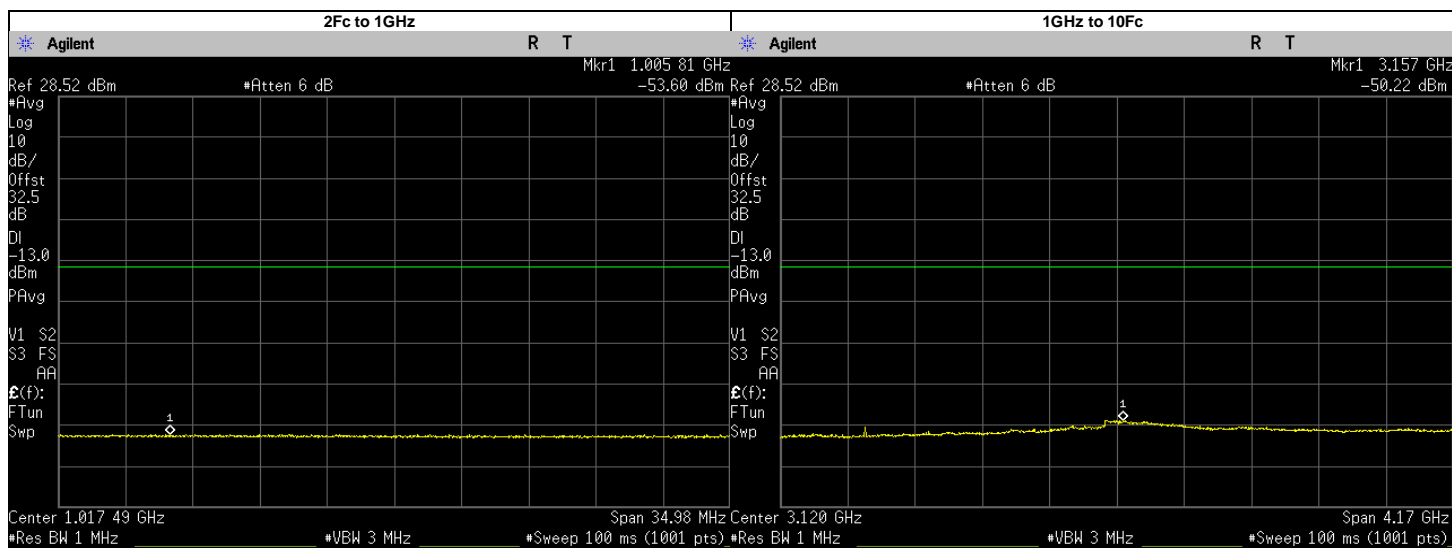
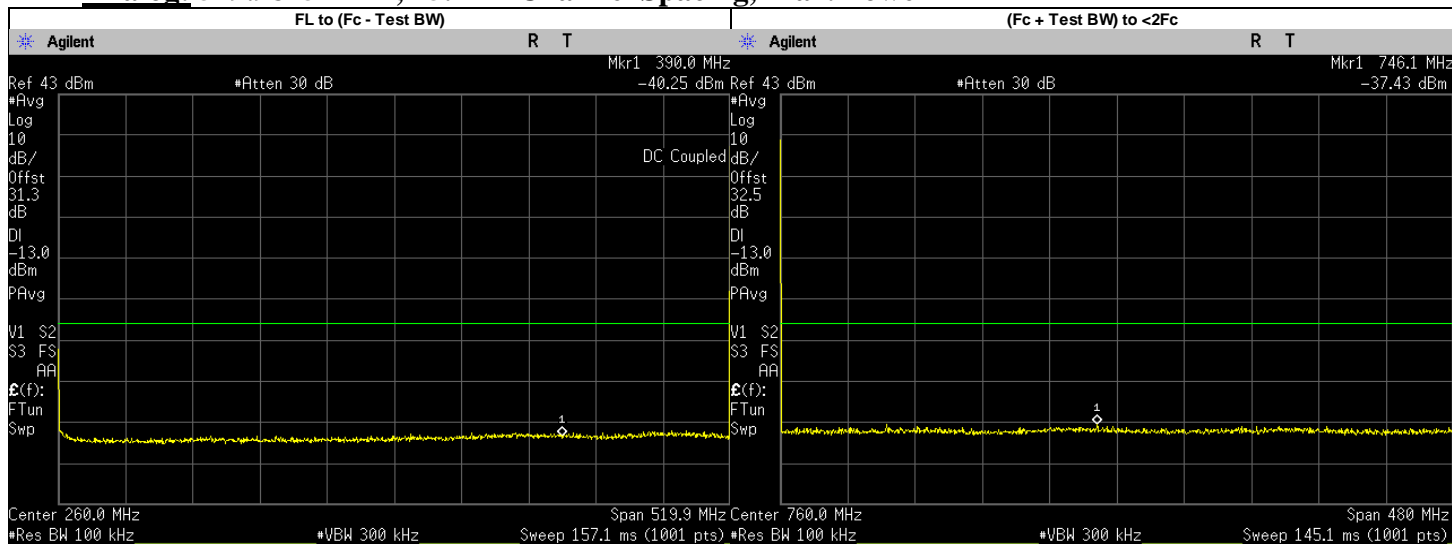

Frequency Range	Highest Spur Frequency (MHz)	Spurious Level (dBm)	Failing Limit (dBm)	Results
FL to (Fc - Test BW)	390.0000	-40.2530	-13.0000	PASS
(Fc + Test BW) to <2Fc	746.1034	-37.4300	-13.0000	PASS
2Fc to 1GHz 1GHz to 10Fc	1005.8060	-53.6000	-13.0000	PASS
	3157.4540	-50.2200	-13.0000	PASS
	1039.9750	-54.3172	-13.0000	PASS
	1559.9630	-52.0692	-13.0000	PASS
	2079.9500	-53.3676	-13.0000	PASS
	2599.9370	-52.7898	-13.0000	PASS
	3639.9120	-52.1438	-13.0000	PASS
	4159.9000	-52.5572	-13.0000	PASS
	4679.8870	-52.7707	-13.0000	PASS
5199.8750	-52.5504	-13.0000	PASS	

**6.9.3. Test Result (Digital)**

**Digital: 380.0125 MHz, 12.5.kHz Channel Spacing, Max. Power**

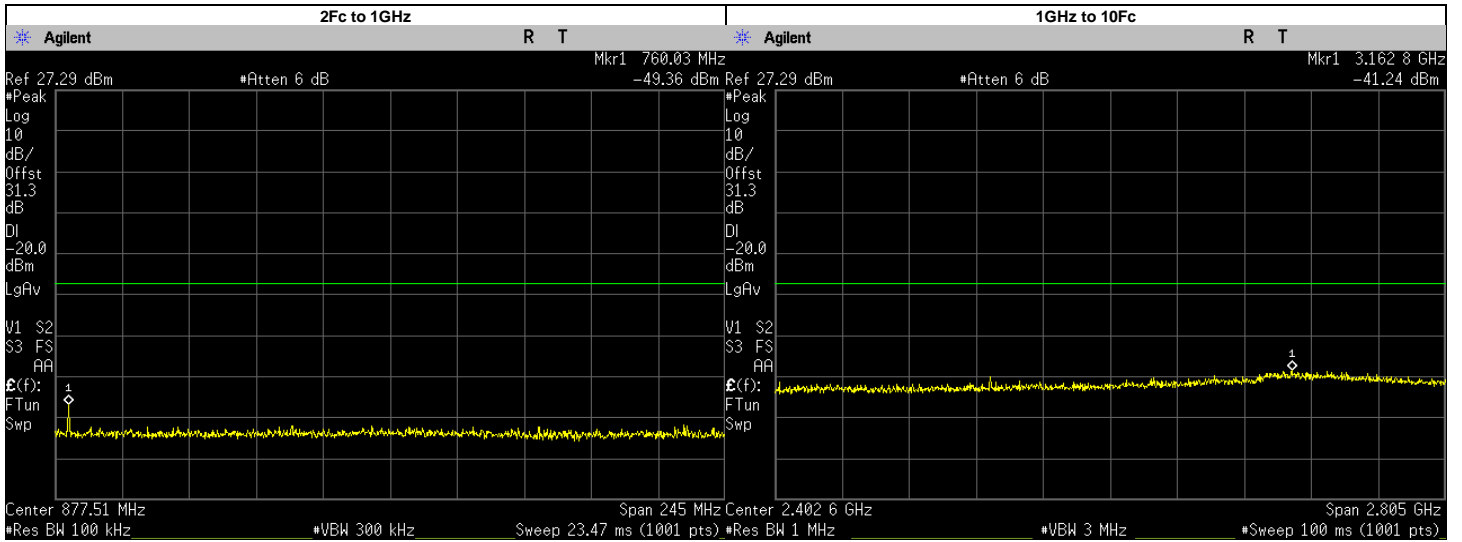
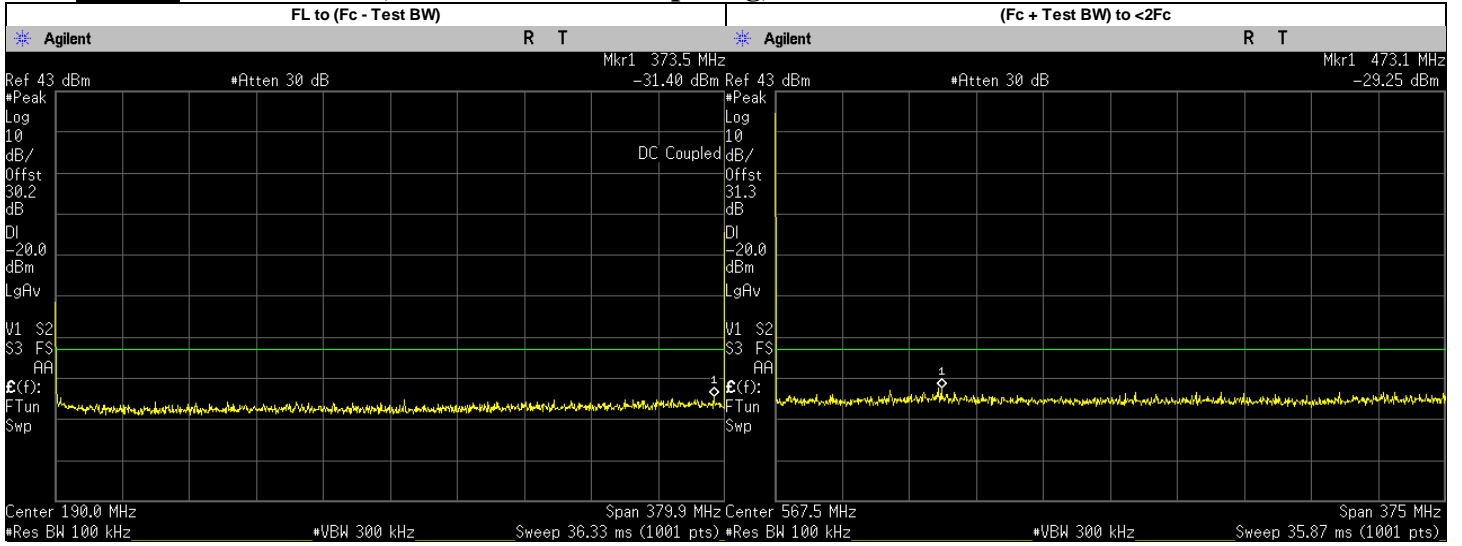

Frequency Range	Highest Spur Frequency (MHz)	Spurious Level (dBm)	Failing Limit (dBm)	Results
FL to (Fc - Test BW)	373.5000	-31.4040	-20.00	PASS
(Fc + Test BW) to <2Fc	473.1074	-29.2500	-20.00	PASS
2Fc to 1GHz 1GHz to 10Fc	760.0250	-49.3601	-20.00	PASS
	3162.7510	-41.2400	-20.00	PASS
	1140.0370	-46.2330	-20.00	PASS
	1520.0500	-45.4936	-20.00	PASS
	1900.0620	-42.9262	-20.00	PASS
	2280.0750	-45.2366	-20.00	PASS
	2660.0880	-43.9887	-20.00	PASS
	3040.1000	-43.5597	-20.00	PASS
	3420.1130	-43.0764	-20.00	PASS
3800.1250	-44.3900	-20.00	PASS	

### Digital: 406.2 MHz, 12.5.kHz Channel Spacing, Max. Power

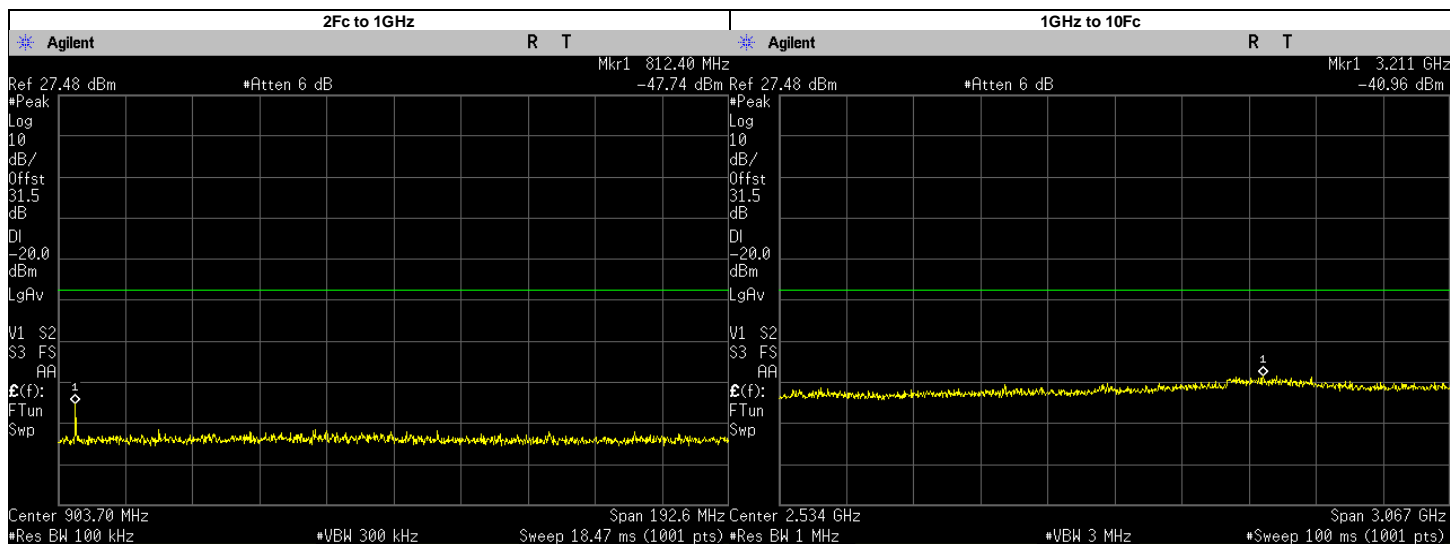
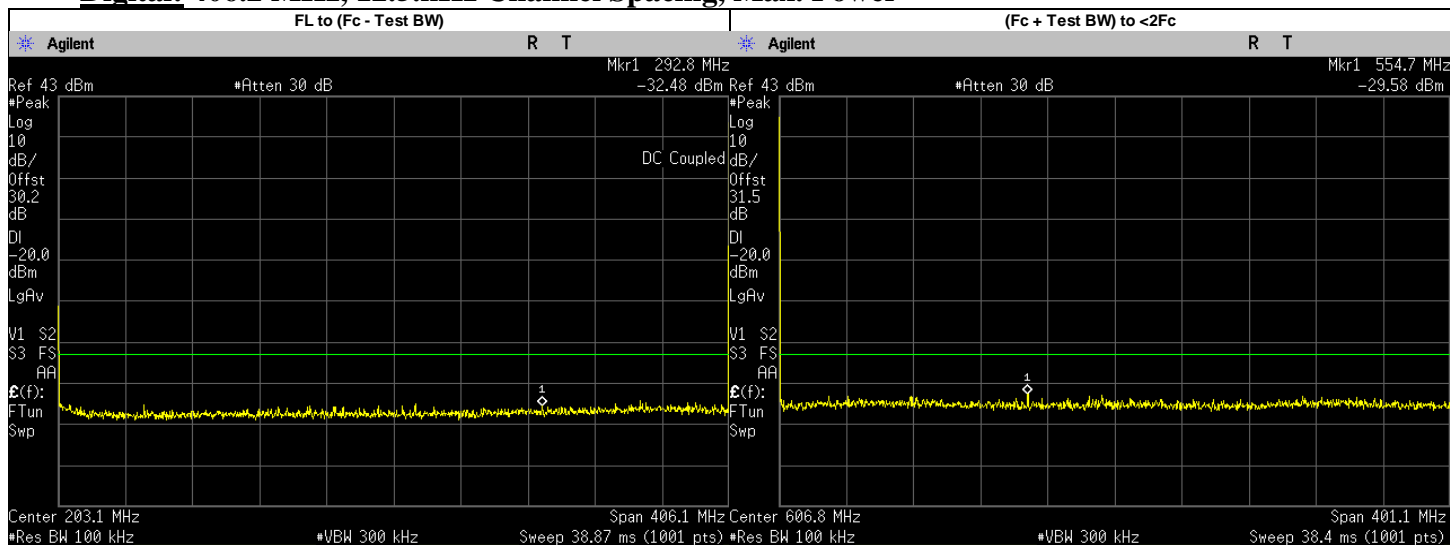

Frequency Range	Highest Spur Frequency (MHz)	Spurious Level (dBm)	Failing Limit (dBm)	Results
FL to (Fc - Test BW)	292.8000	-32.4840	-20.00	PASS
(Fc + Test BW) to <2Fc	554.6790	-29.5800	-20.00	PASS
2Fc to 1GHz	812.4000	-47.7408	-20.00	PASS
1GHz to 10Fc	3211.3070	-40.9600	-20.00	PASS
	1218.6000	-45.5018	-20.00	PASS
	1624.8000	-45.5665	-20.00	PASS
	2031.0000	-43.2080	-20.00	PASS
	2437.2000	-44.8795	-20.00	PASS
	2843.4000	-43.6811	-20.00	PASS
	3249.6000	-42.2345	-20.00	PASS
	3655.8000	-44.0904	-20.00	PASS
	4062.0000	-43.9418	-20.00	PASS

**Digital: 450.025 MHz, 12.5.kHz Channel Spacing, Max. Power**

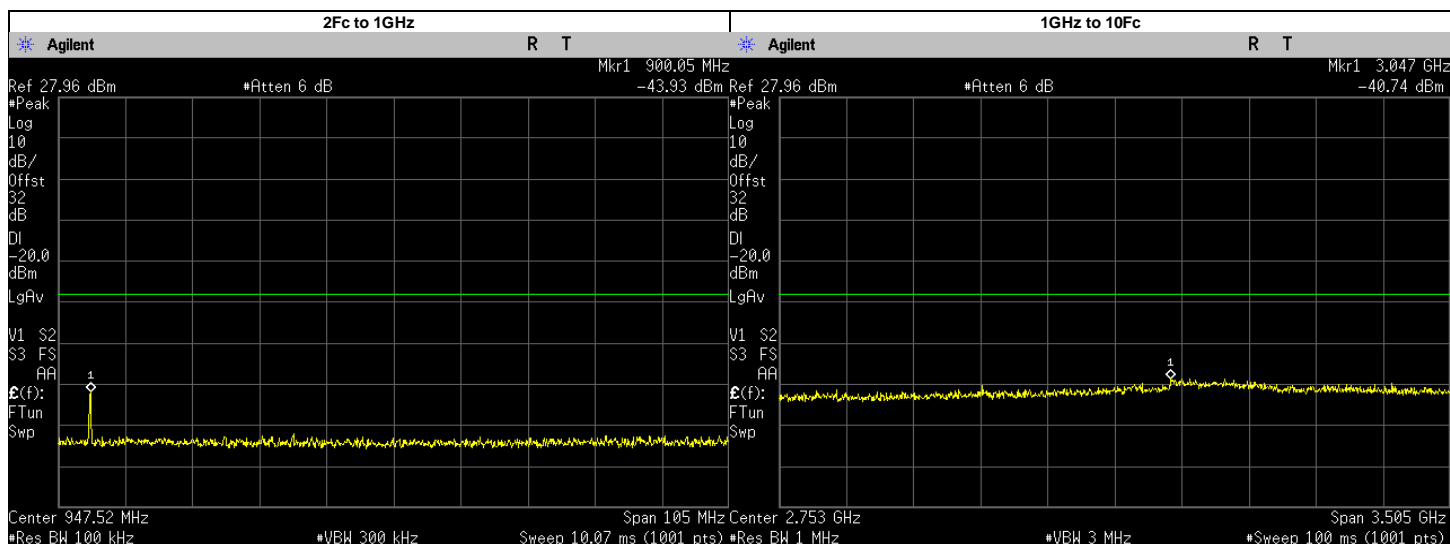
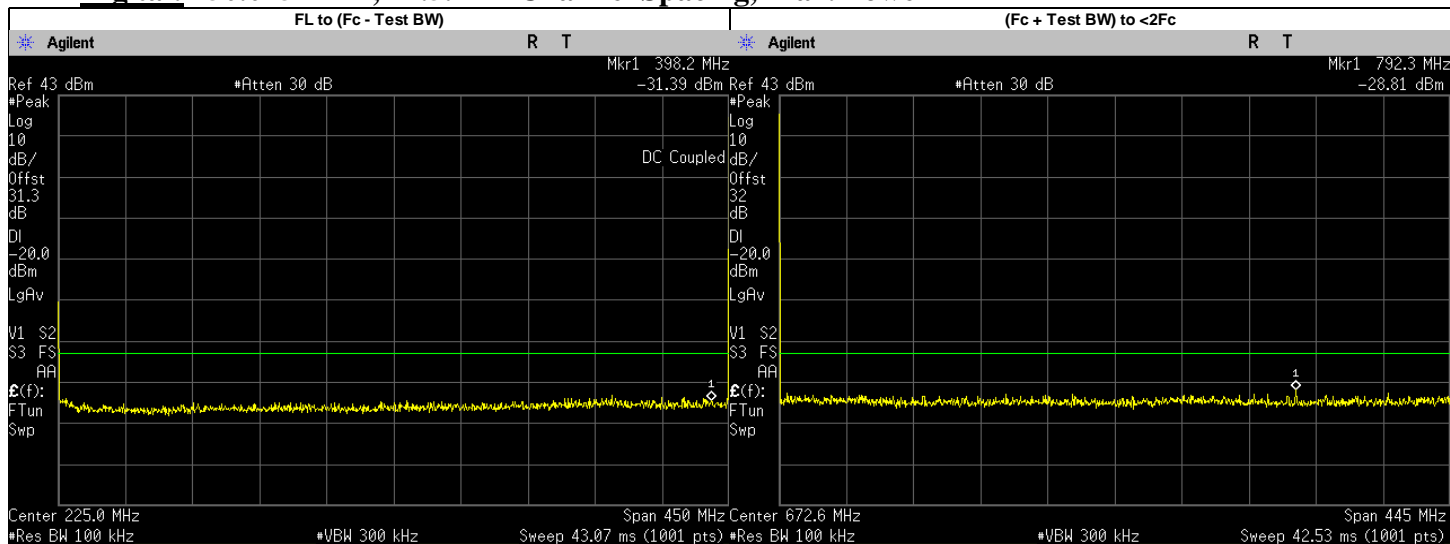

Frequency Range	Highest Spur Frequency (MHz)	Spurious Level (dBm)	Failing Limit (dBm)	Results
FL to (Fc - Test BW)	437.8000	-31.3900	-20.00	PASS
(Fc + Test BW) to <2Fc	792.2623	-28.8100	-20.00	PASS
2Fc to 1GHz 1GHz to 10Fc	900.0500	-43.9300	-20.00	PASS
	3047.0660	-40.7400	-20.00	PASS
	1350.0750	-44.1039	-20.00	PASS
	1800.1000	-44.7231	-20.00	PASS
	2250.1250	-43.8733	-20.00	PASS
	2700.1500	-43.5722	-20.00	PASS
	3150.1750	-42.3411	-20.00	PASS
	3600.2000	-42.1105	-20.00	PASS
	4050.2250	-43.7004	-20.00	PASS
4500.2500	-43.9486	-20.00	PASS	

**Digital: 450.025 MHz, 12.5.kHz Channel Spacing, Low. Power**

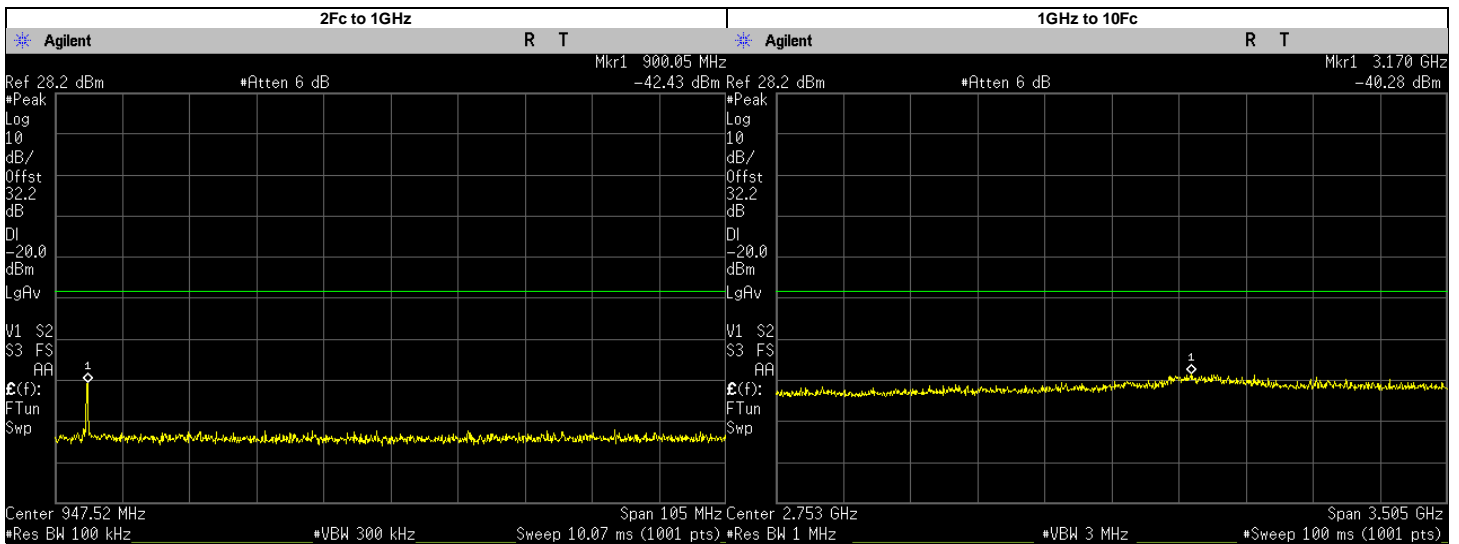
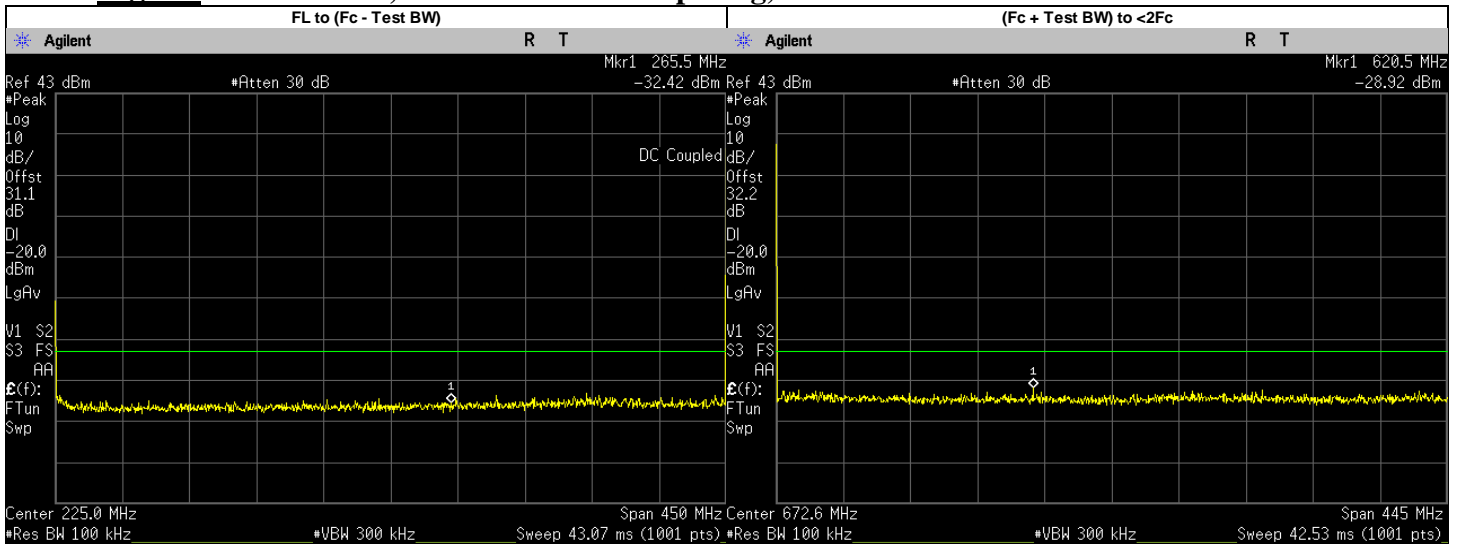

Frequency Range	Highest Spur Frequency (MHz)	Spurious Level (dBm)	Failing Limit (dBm)	Results
FL to (Fc - Test BW)	265.5000	-32.4220	-20.00	PASS
(Fc + Test BW) to <2Fc	620.5046	-28.9200	-20.00	PASS
2Fc to 1GHz 1GHz to 10Fc	900.0500	-42.5030	-20.00	PASS
	3169.7500	-40.2800	-20.00	PASS
	1350.0750	-45.0197	-20.00	PASS
	1800.1000	-43.3940	-20.00	PASS
	2250.1250	-44.0361	-20.00	PASS
	2700.1500	-43.7133	-20.00	PASS
	3150.1750	-41.4891	-20.00	PASS
	3600.2000	-42.5307	-20.00	PASS
	4050.2250	-43.0766	-20.00	PASS
4500.2500	-43.6037	-20.00	PASS	

**Digital: 459.125 MHz, 12.5.kHz Channel Spacing, Max. Power**

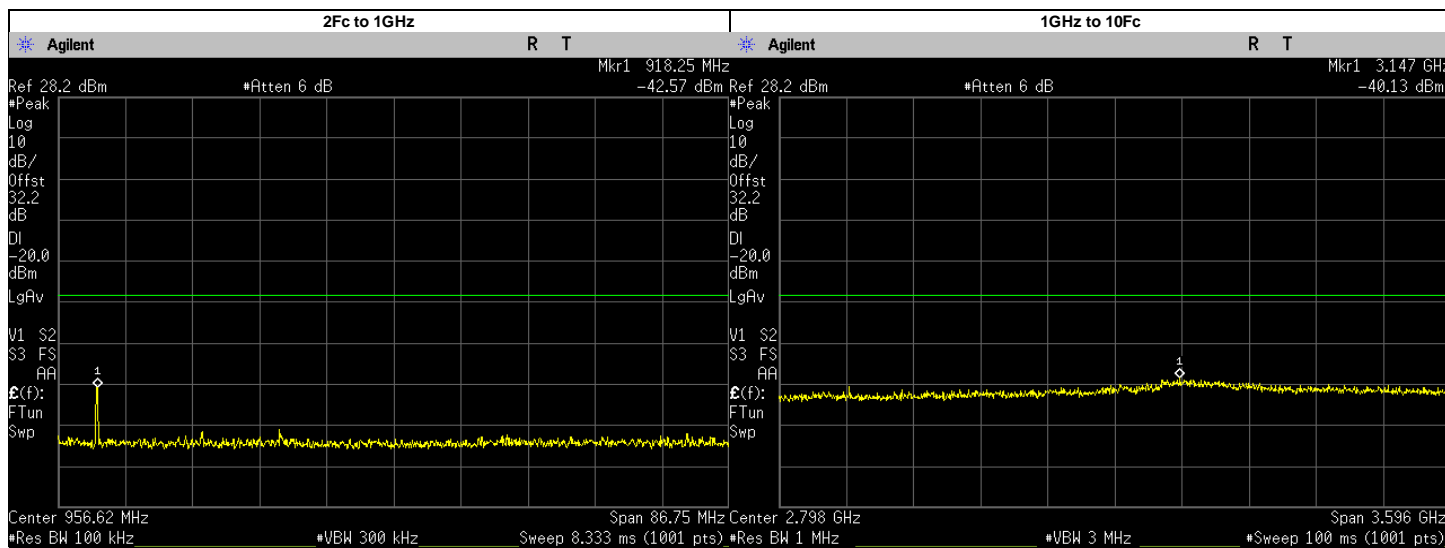
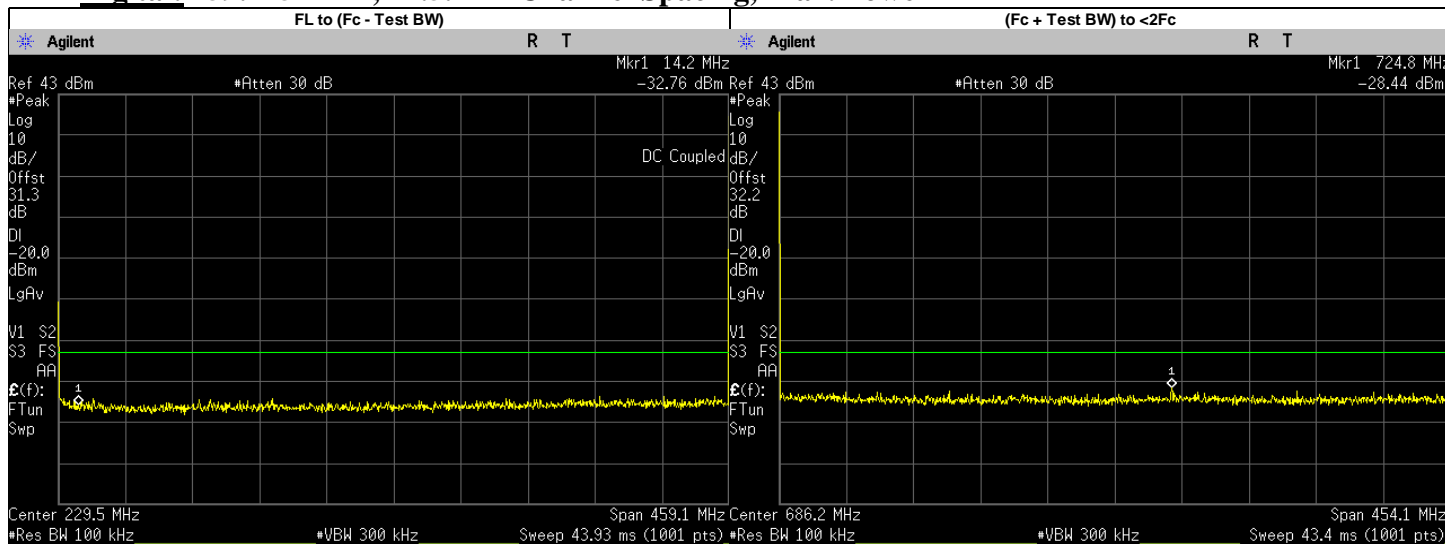

Frequency Range	Highest Spur Frequency (MHz)	Spurious Level (dBm)	Failing Limit (dBm)	Results
FL to (Fc - Test BW)	14.2000	-32.7630	-20.00	PASS
(Fc + Test BW) to <2Fc	724.8117	-28.4400	-20.00	PASS
2Fc to 1GHz 1GHz to 10Fc	918.2500	-42.5875	-20.00	PASS
	3146.9610	-40.1300	-20.00	PASS
	1377.3750	-42.3636	-20.00	PASS
	1836.5000	-44.9789	-20.00	PASS
	2295.6250	-43.5743	-20.00	PASS
	2754.7500	-43.7253	-20.00	PASS
	3213.8750	-41.1795	-20.00	PASS
	3673.0000	-43.5483	-20.00	PASS
	4132.1250	-43.3167	-20.00	PASS
4591.2500	-43.3663	-20.00	PASS	



**Digital: 467.775 MHz, 12.5.kHz Channel Spacing, Max. Power**

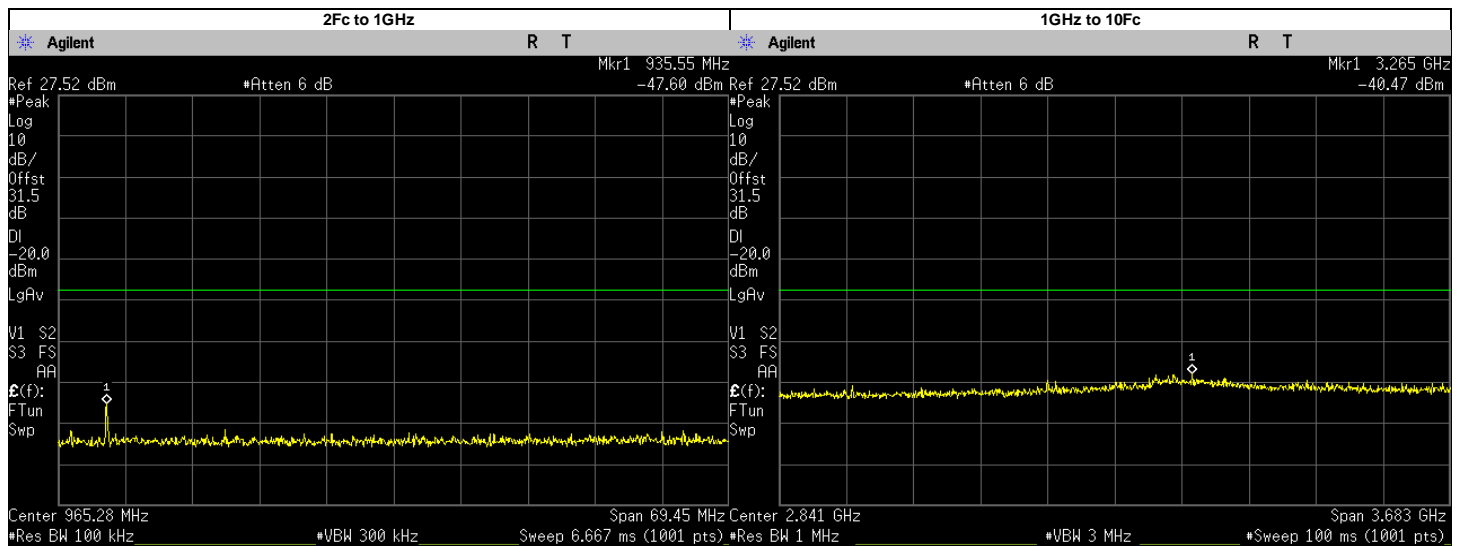
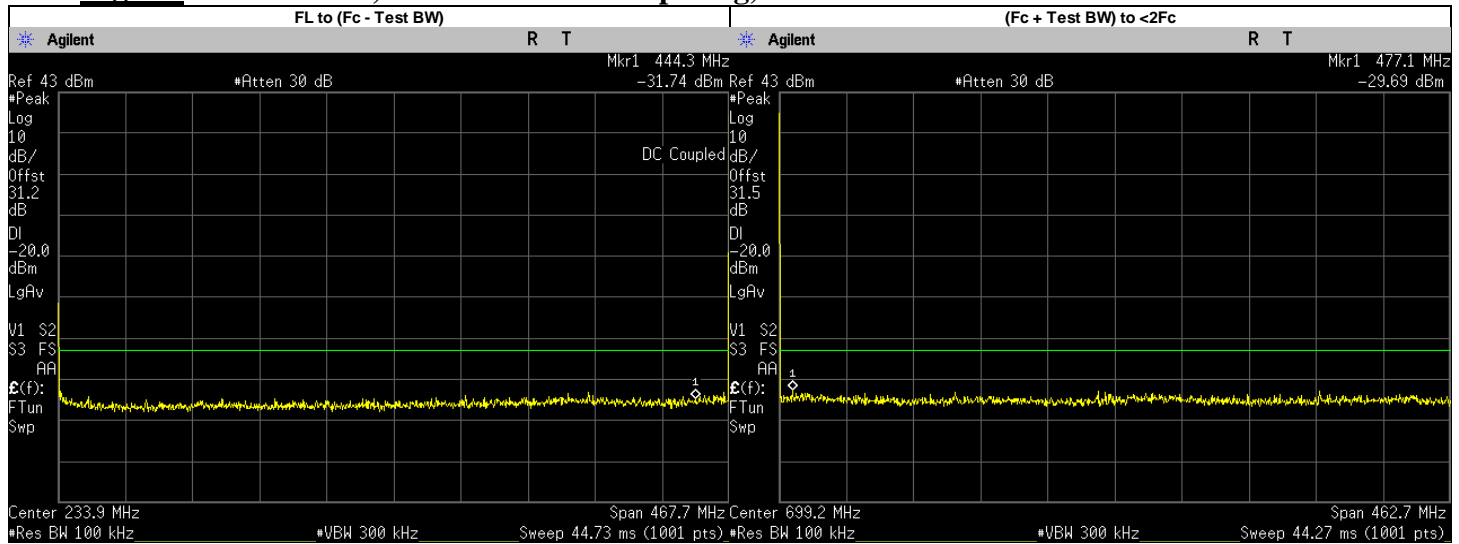

Frequency Range	Highest Spur Frequency (MHz)	Spurious Level (dBm)	Failing Limit (dBm)	Results
FL to (Fc - Test BW)	444.3000	-31.7370	-20.00	PASS
(Fc + Test BW) to <2Fc	477.0862	-29.6900	-20.00	PASS
2Fc to 1GHz 1GHz to 10Fc	935.5500	-47.6024	-20.00	PASS
	3264.8910	-40.4700	-20.00	PASS
	1403.3250	-43.5509	-20.00	PASS
	1871.1000	-45.2865	-20.00	PASS
	2338.8750	-44.5023	-20.00	PASS
	2806.6500	-44.5323	-20.00	PASS
	3274.4250	-42.1047	-20.00	PASS
	3742.2000	-44.0114	-20.00	PASS
	4209.9750	-44.2051	-20.00	PASS
4677.7500	-44.4993	-20.00	PASS	

**Digital: 482.0125 MHz, 12.5.kHz Channel Spacing, Max. Power**

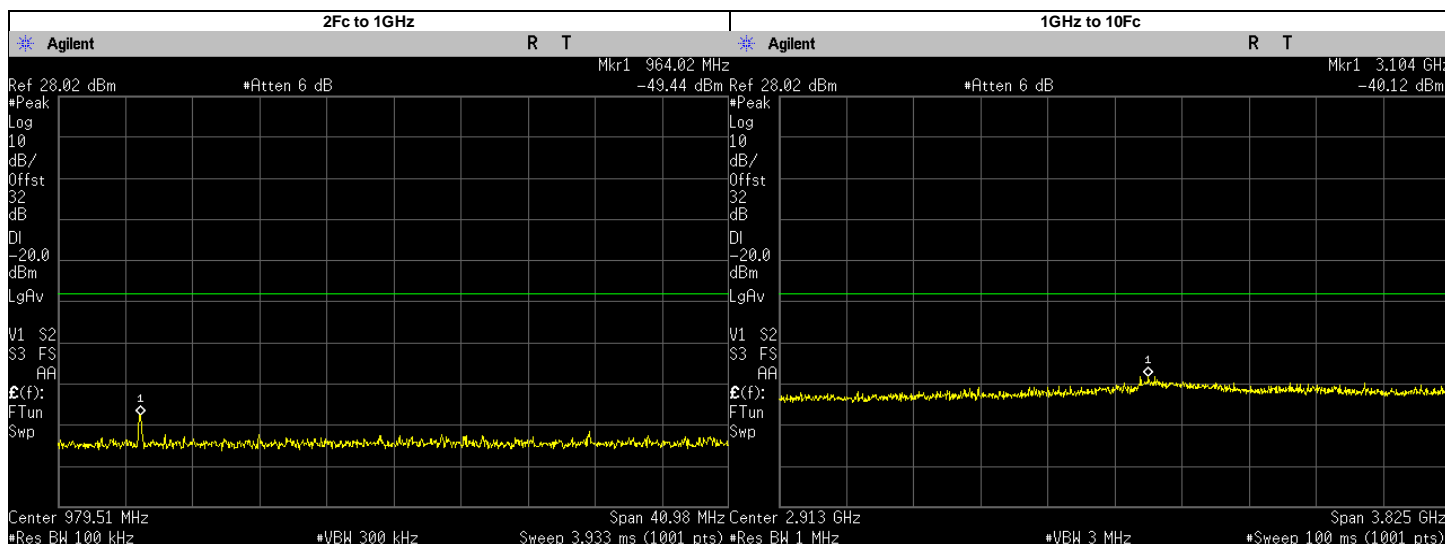
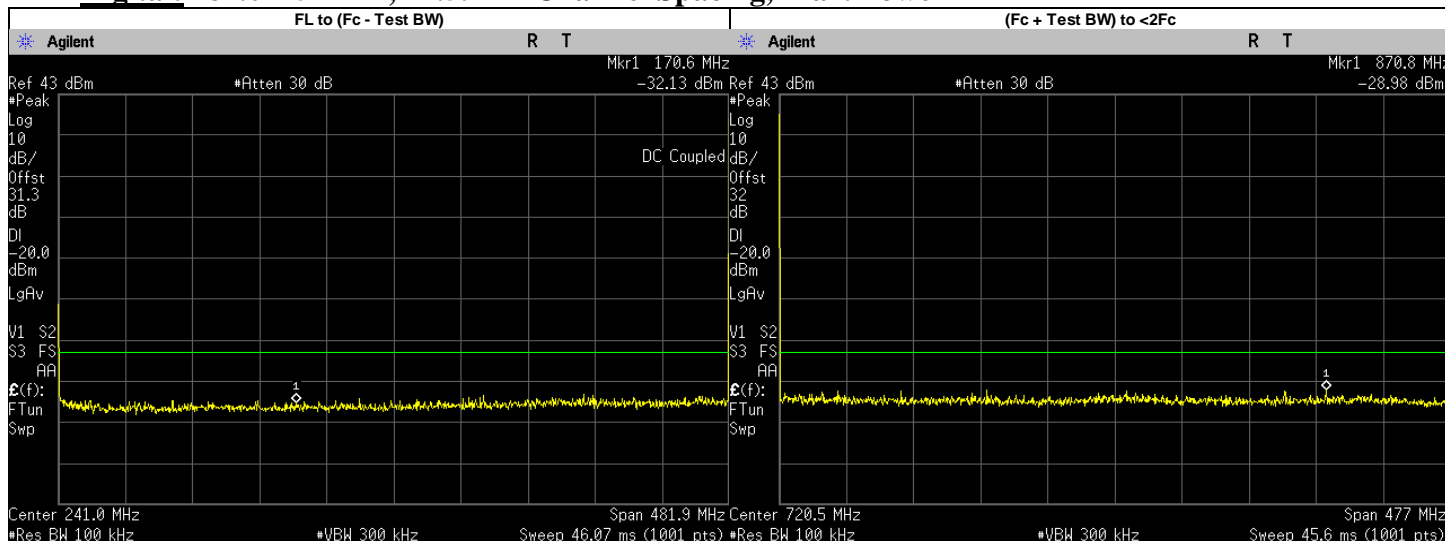

Frequency Range	Highest Spur Frequency (MHz)	Spurious Level (dBm)	Failing Limit (dBm)	Results
FL to (Fc - Test BW)	170.6000	-32.1320	-20.00	PASS
(Fc + Test BW) to <2Fc	870.7882	-28.9800	-20.00	PASS
2Fc to 1GHz 1GHz to 10Fc	964.0250	-49.4395	-20.00	PASS
	3103.8190	-40.1200	-20.00	PASS
	1446.0370	-44.0892	-20.00	PASS
	1928.0500	-44.7423	-20.00	PASS
	2410.0620	-44.6823	-20.00	PASS
	2892.0750	-43.6323	-20.00	PASS
	3374.0880	-42.7089	-20.00	PASS
	3856.1000	-43.6543	-20.00	PASS
	4338.1130	-41.9290	-20.00	PASS
4820.1250	-43.9207	-20.00	PASS	

**Digital: 511.9875 MHz, 12.5.kHz Channel Spacing, Max. Power**

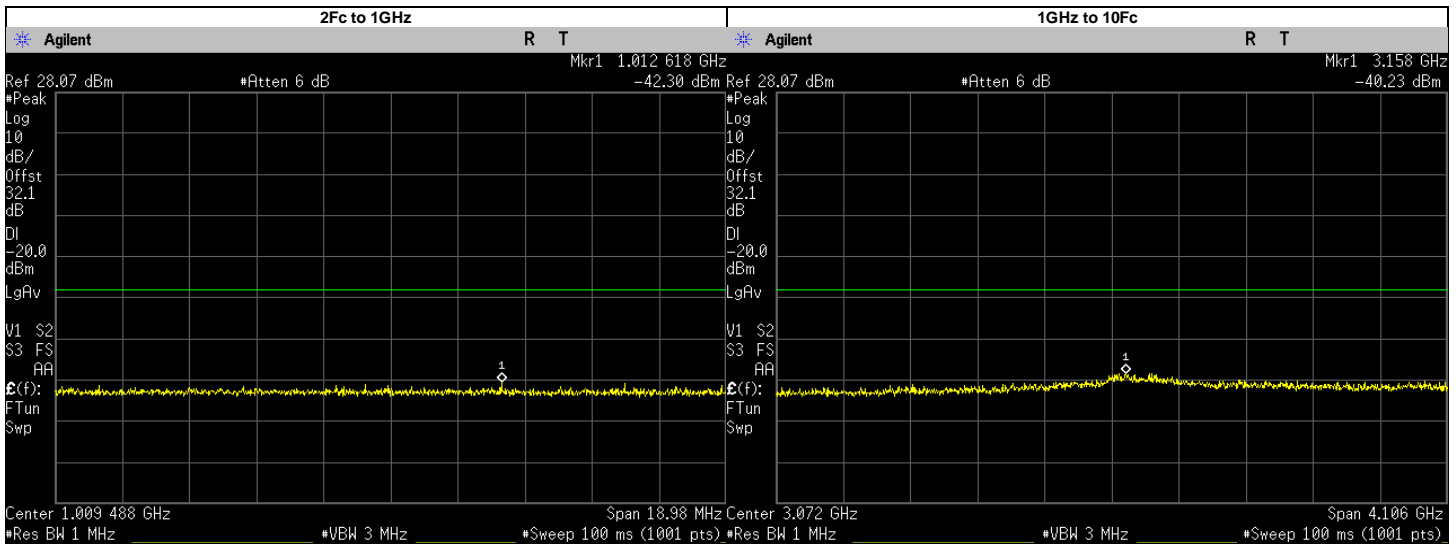
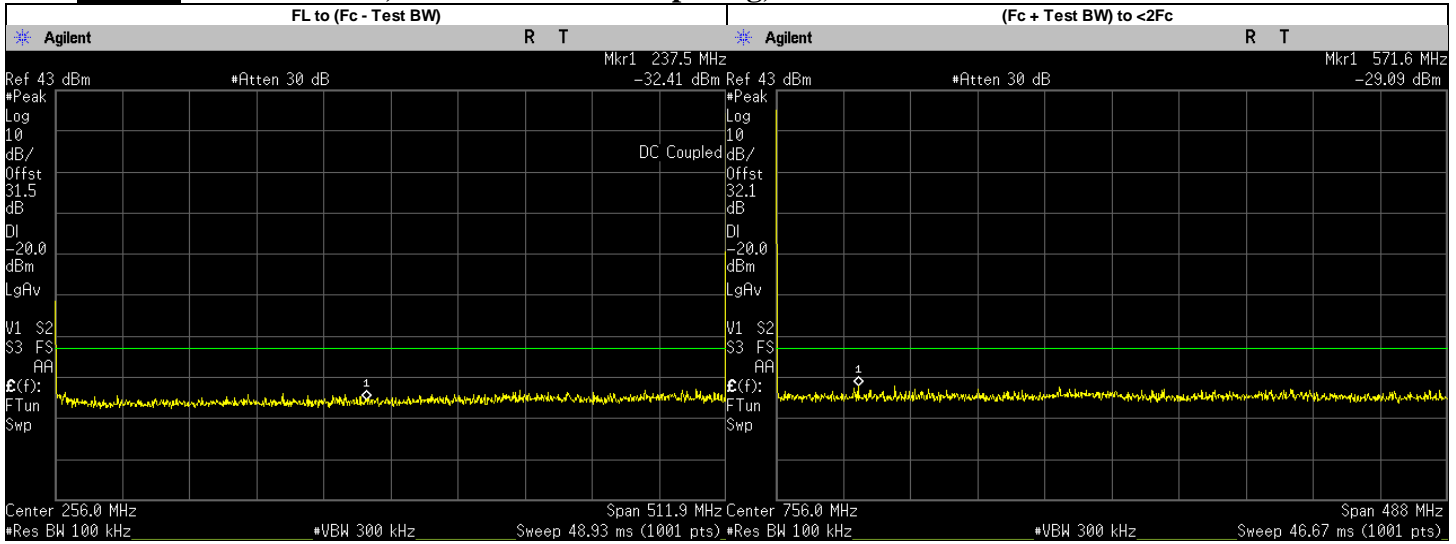

Frequency Range	Highest Spur Frequency (MHz)	Spurious Level (dBm)	Failing Limit (dBm)	Results
FL to (Fc - Test BW)	237.5000	-32.4070	-20.00	PASS
(Fc + Test BW) to <2Fc	571.5749	-29.0900	-20.00	PASS
2Fc to 1GHz 1GHz to 10Fc	1012.6180	-42.3000	-20.00	PASS
	3158.1490	-40.2300	-20.00	PASS
	1023.9750	-45.5574	-20.00	PASS
	1535.9630	-43.8037	-20.00	PASS
	2047.9500	-44.6174	-20.00	PASS
	2559.9370	-44.0414	-20.00	PASS
	3583.9120	-42.9804	-20.00	PASS
	4095.9000	-43.1437	-20.00	PASS
	4607.8870	-44.1743	-20.00	PASS
	5119.8750	-44.2113	-20.00	PASS

**Digital: 511.9875 MHz, 12.5.kHz Channel Spacing, Low. Power**

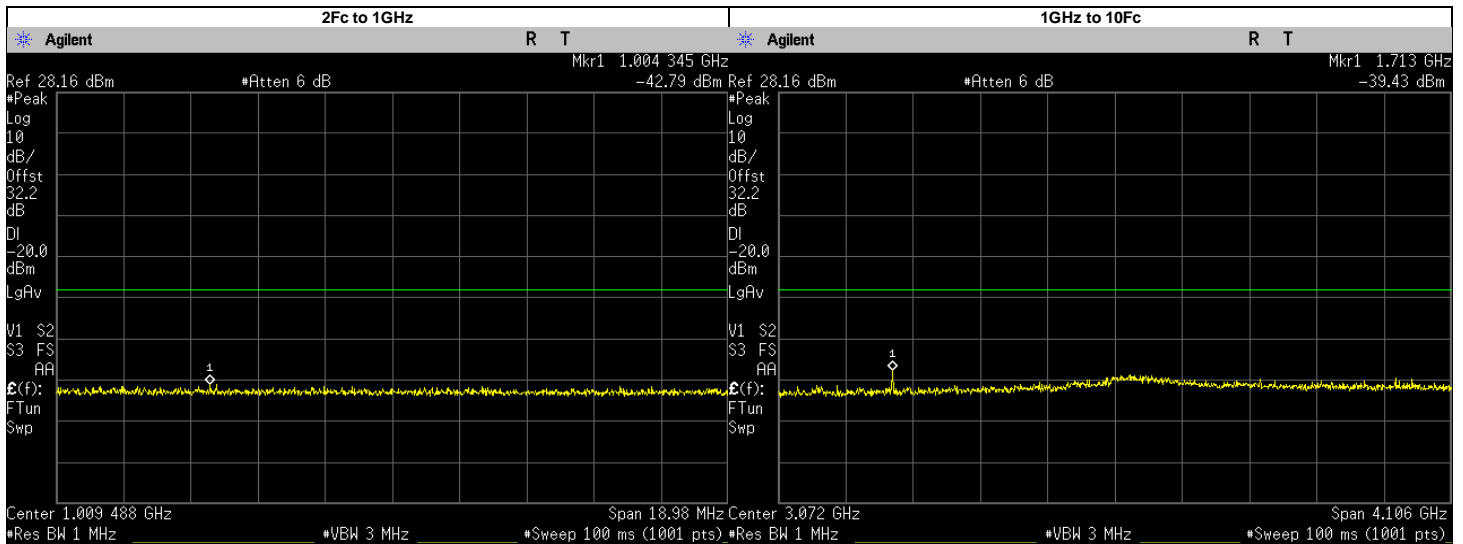
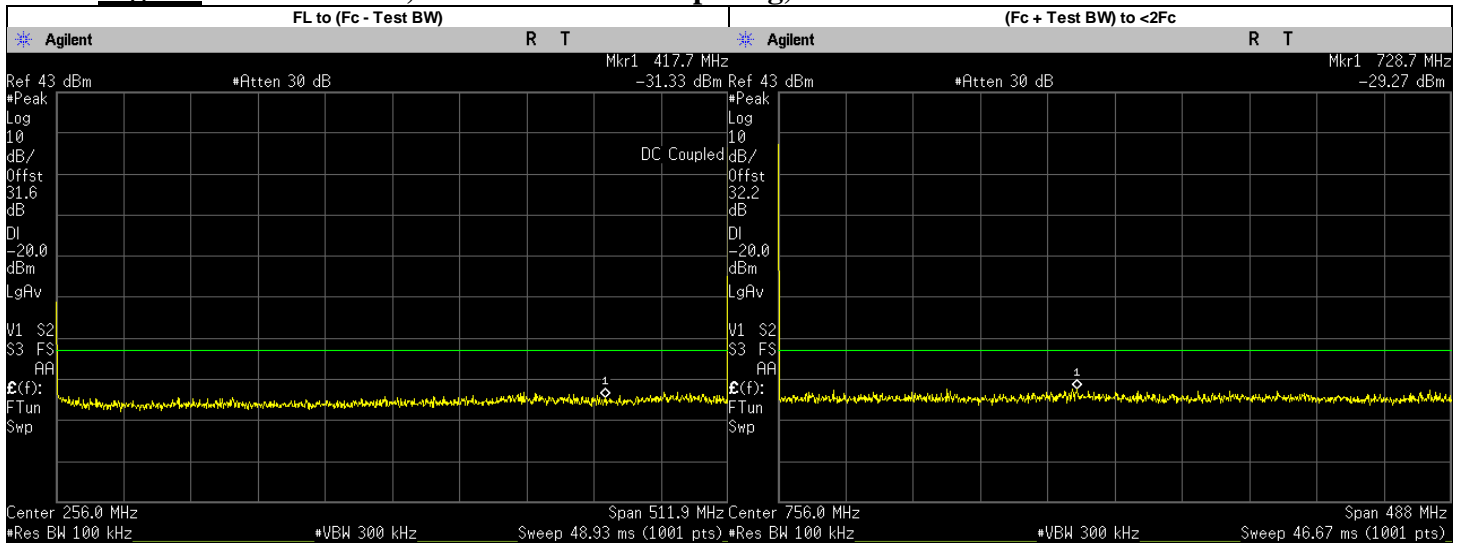

Frequency Range	Highest Spur Frequency (MHz)	Spurious Level (dBm)	Failing Limit (dBm)	Results
FL to (Fc - Test BW)	417.7000	-31.3300	-20.00	PASS
(Fc + Test BW) to <2Fc	728.6966	-29.2700	-20.00	PASS
2Fc to 1GHz 1GHz to 10Fc	1004.3450	-42.7900	-20.00	PASS
	1712.8720	-39.4300	-20.00	PASS
	1535.9630	-43.9008	-20.00	PASS
	2047.9500	-44.4440	-20.00	PASS
	2559.9370	-43.9223	-20.00	PASS
	3071.9250	-41.2510	-20.00	PASS
	3583.9120	-43.1671	-20.00	PASS
	4095.9000	-43.5707	-20.00	PASS
	4607.8870	-43.1012	-20.00	PASS
5119.8750	-44.0374	-20.00	PASS	

**Digital: 519.9875 MHz, 12.5.kHz Channel Spacing, Max. Power**

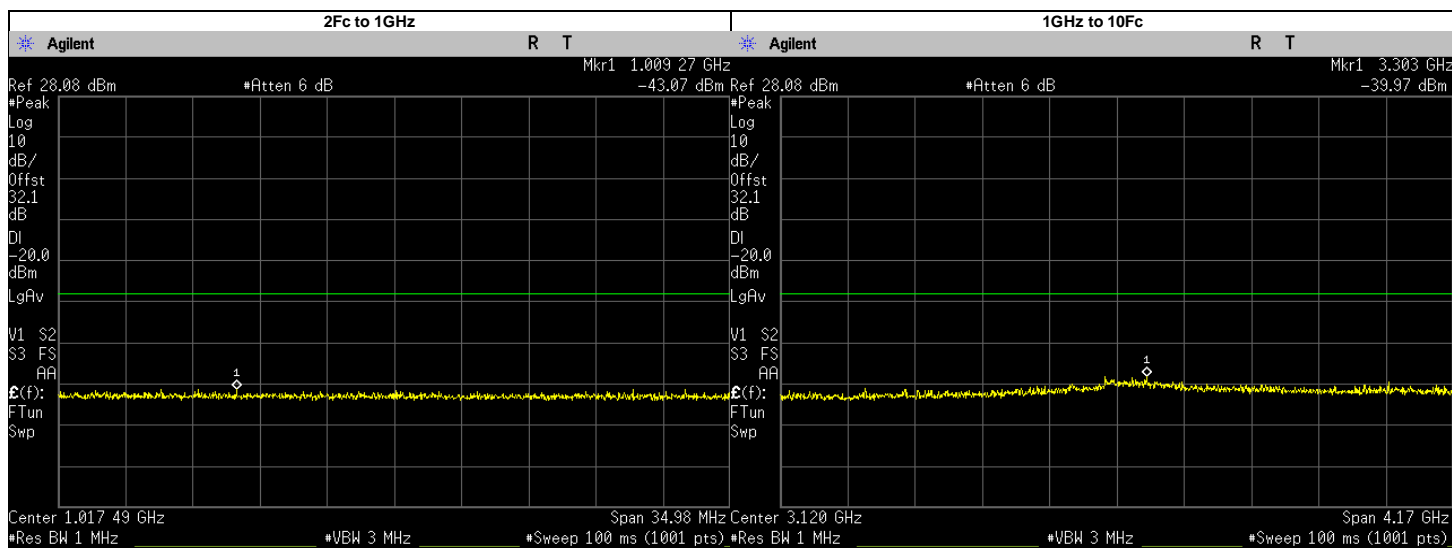
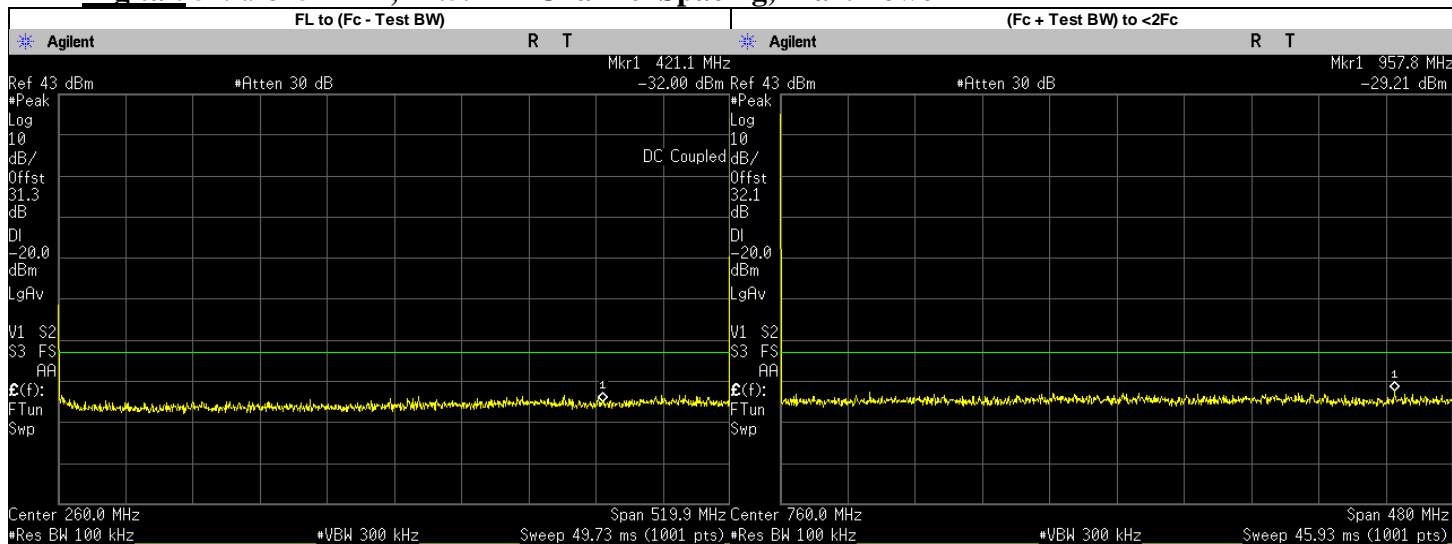

Frequency Range	Highest Spur Frequency (MHz)	Spurious Level (dBm)	Failing Limit (dBm)	Results
FL to (Fc - Test BW)	421.1000	-31.9990	-20.00	PASS
(Fc + Test BW) to <2Fc	957.7639	-29.2100	-20.00	PASS
2Fc to 1GHz 1GHz to 10Fc	1009.2680	-43.0700	-20.00	PASS
	3303.4010	-39.9700	-20.00	PASS
	1559.9630	-43.1886	-20.00	PASS
	2079.9500	-44.4166	-20.00	PASS
	2599.9370	-43.4328	-20.00	PASS
	3119.9250	-41.7730	-20.00	PASS
	3639.9120	-43.2309	-20.00	PASS
	4159.9000	-43.6010	-20.00	PASS
	4679.8870	-43.1133	-20.00	PASS
5199.8750	-43.5255	-20.00	PASS	

**Phase II: 380.0125 MHz, 12.5.kHz Channel Spacing, Max. Power**

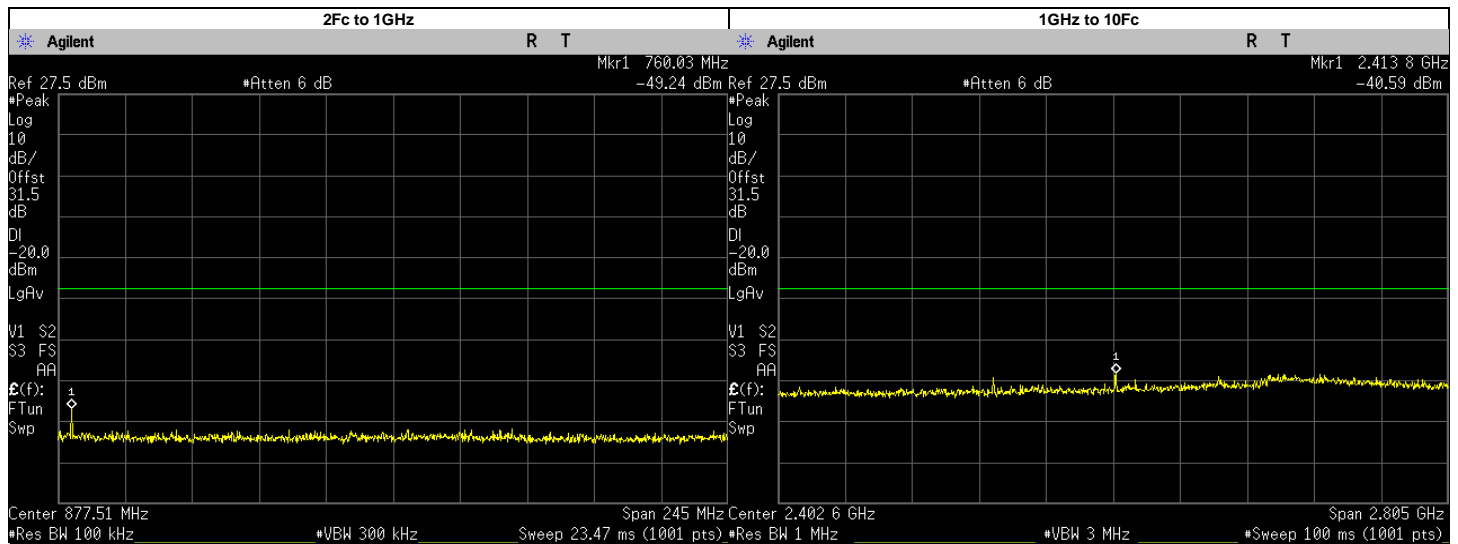
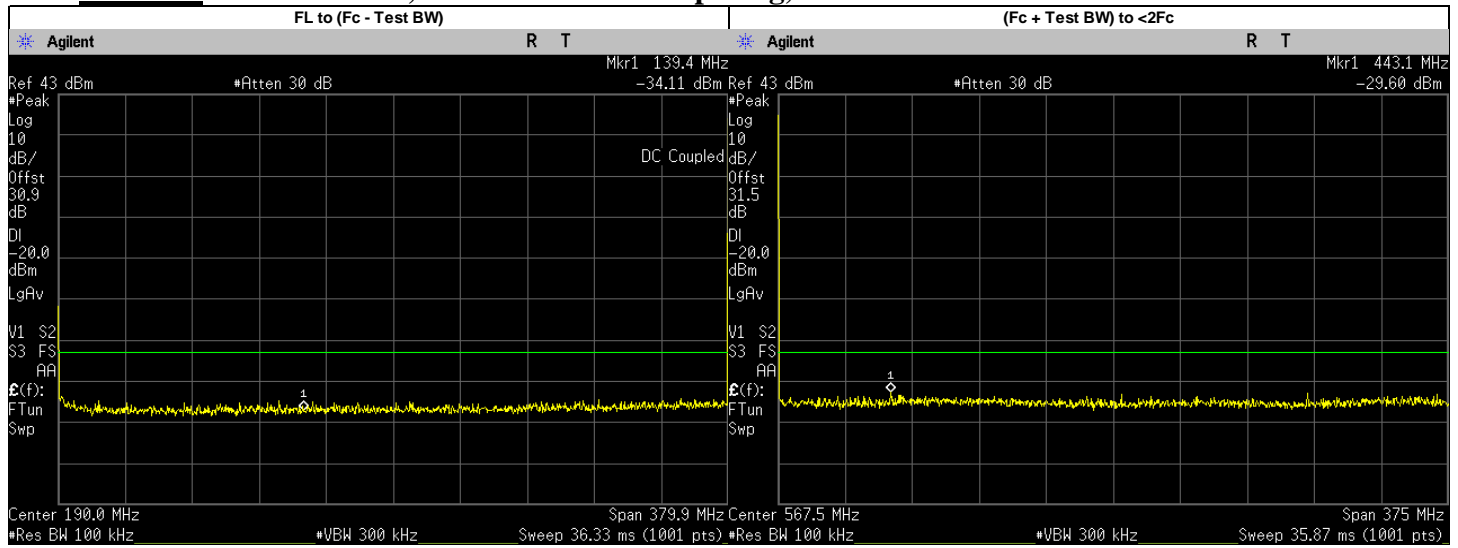

Frequency Range	Highest Spur Frequency (MHz)	Spurious Level (dBm)	Failing Limit (dBm)	Results
FL to (Fc - Test BW)	139.4000	-34.1140	-20.00	PASS
(Fc + Test BW) to <2Fc	443.0609	-29.6000	-20.00	PASS
2Fc to 1GHz 1GHz to 10Fc	760.0250	-49.2366	-20.00	PASS
	2413.7830	-40.5900	-20.00	PASS
	1140.0370	-45.7955	-20.00	PASS
	1520.0500	-44.7035	-20.00	PASS
	1900.0620	-42.1227	-20.00	PASS
	2280.0750	-44.6545	-20.00	PASS
	2660.0880	-44.2387	-20.00	PASS
	3040.1000	-43.3492	-20.00	PASS
	3420.1130	-43.5422	-20.00	PASS
	3800.1250	-43.7585	-20.00	PASS

**Phase II: 406.2 MHz, 12.5.kHz Channel Spacing, Max. Power**

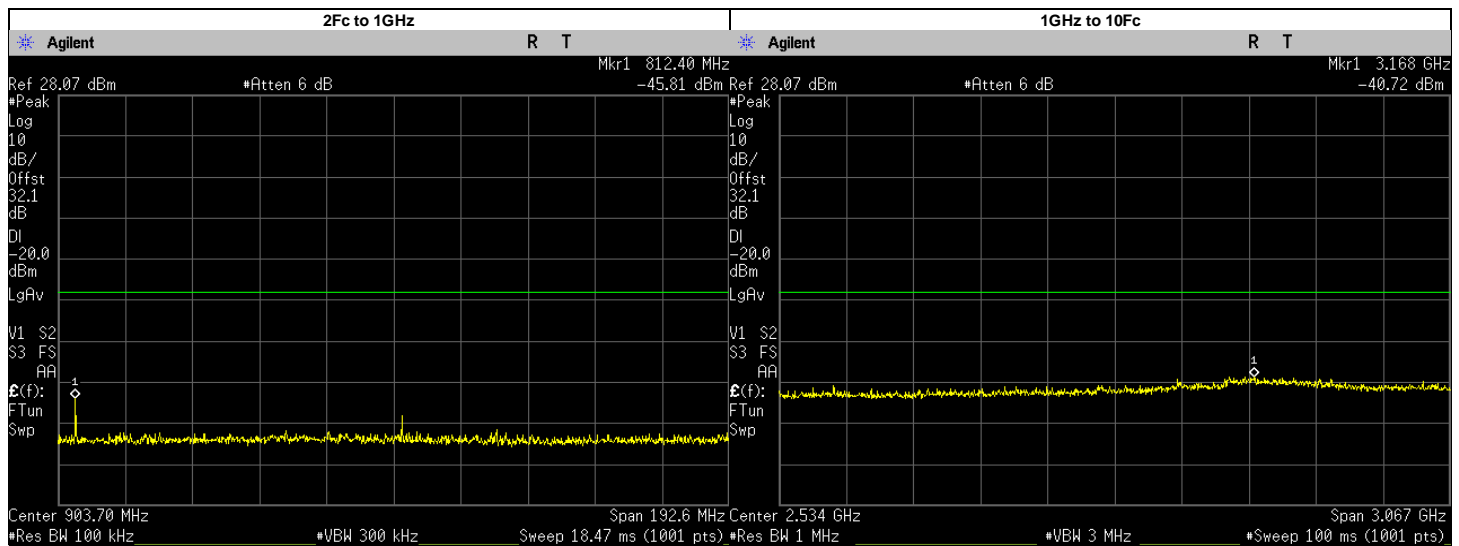
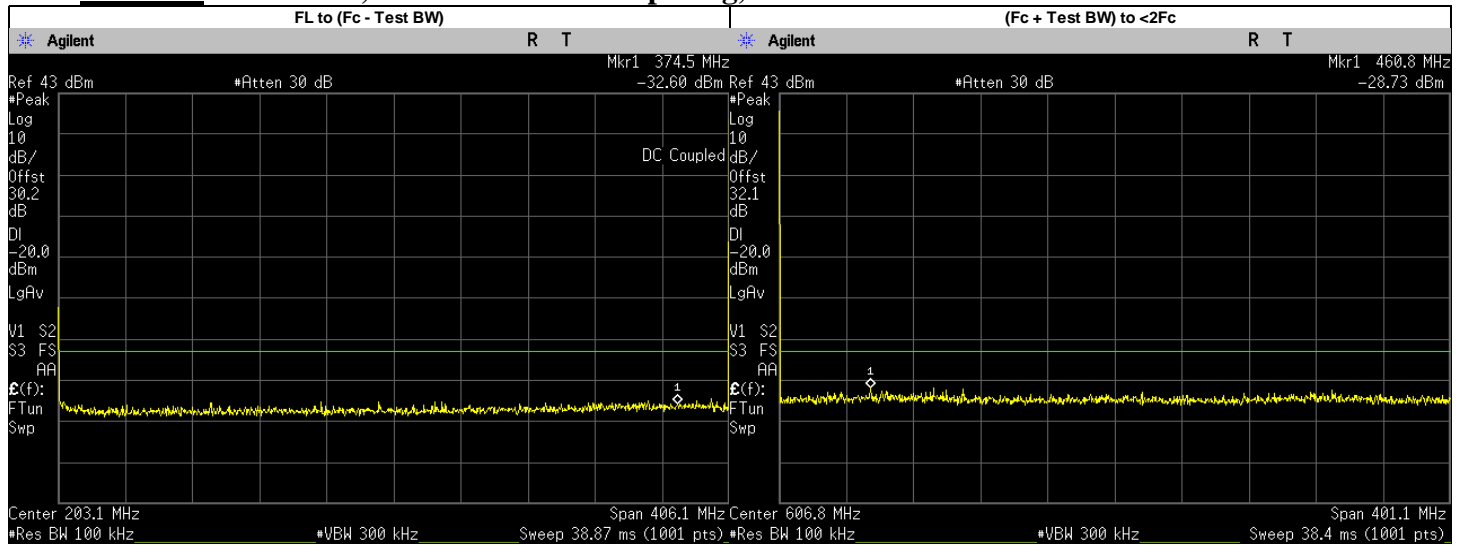

Frequency Range	Highest Spur Frequency (MHz)	Spurious Level (dBm)	Failing Limit (dBm)	Results
FL to (Fc - Test BW)	374.5000	-32.6010	-20.00	PASS
(Fc + Test BW) to <2Fc	460.8113	-28.7300	-20.00	PASS
2Fc to 1GHz 1GHz to 10Fc	812.4000	-45.8118	-20.00	PASS
	3168.3690	-40.7200	-20.00	PASS
	1218.6000	-44.7627	-20.00	PASS
	1624.8000	-45.1312	-20.00	PASS
	2031.0000	-43.1174	-20.00	PASS
	2437.2000	-44.4484	-20.00	PASS
	2843.4000	-43.1861	-20.00	PASS
	3249.6000	-42.0720	-20.00	PASS
	3655.8000	-43.4222	-20.00	PASS
4062.0000	-43.4760	-20.00	PASS	

### Phase II: 450.025 MHz, 12.5.kHz Channel Spacing, Max. Power

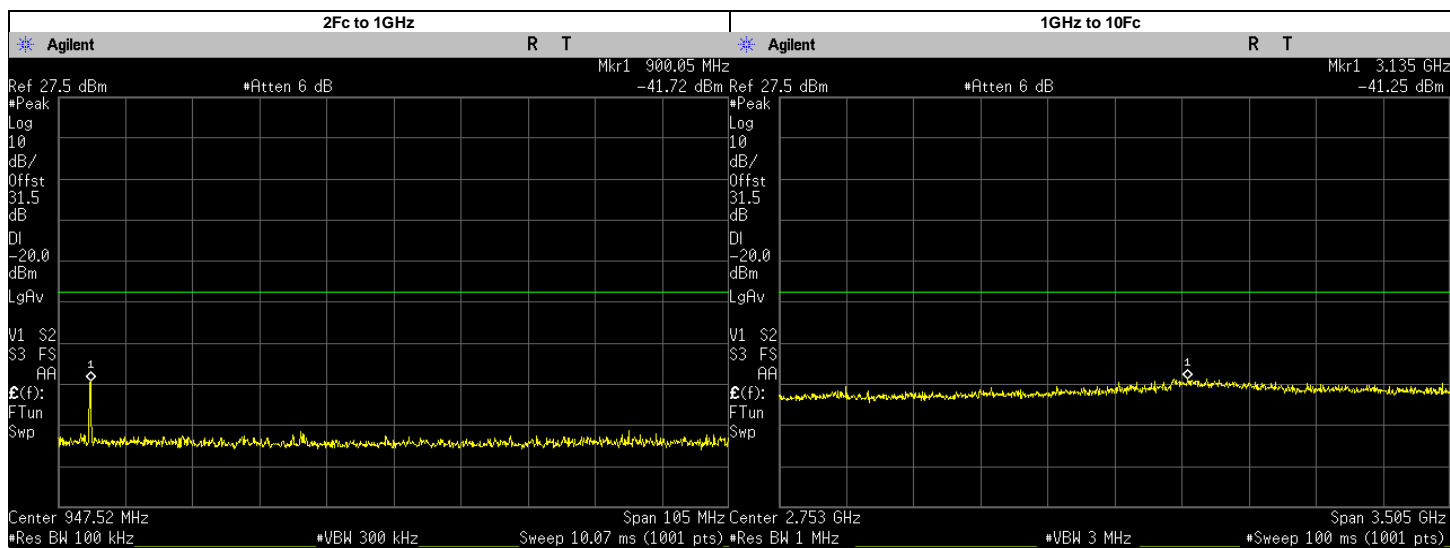
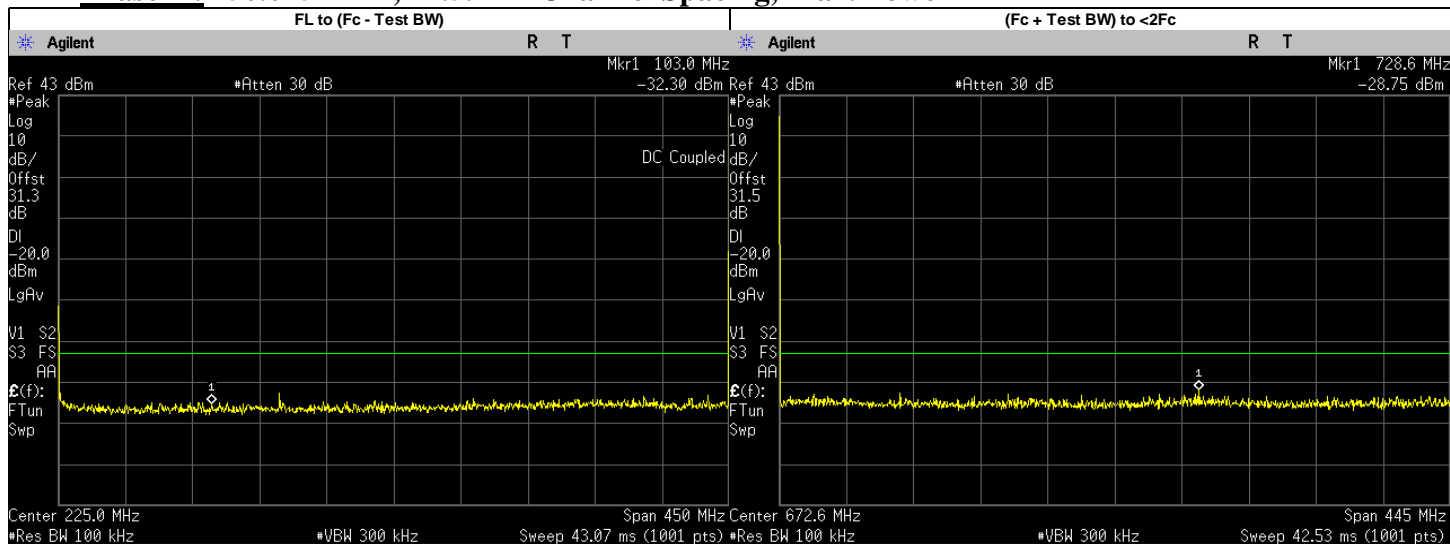

Frequency Range	Highest Spur Frequency (MHz)	Spurious Level (dBm)	Failing Limit (dBm)	Results
FL to (Fc - Test BW)	103.0000	-32.3000	-20.00	PASS
(Fc + Test BW) to <2Fc	728.6319	-28.7500	-20.00	PASS
2Fc to 1GHz 1GHz to 10Fc	900.0500	-41.7218	-20.00	PASS
	3134.6970	-41.2500	-20.00	PASS
	1350.0750	-43.4120	-20.00	PASS
	1800.1000	-44.4480	-20.00	PASS
	2250.1250	-44.5400	-20.00	PASS
	2700.1500	-44.1263	-20.00	PASS
	3150.1750	-42.3605	-20.00	PASS
	3600.2000	-43.1793	-20.00	PASS
	4050.2250	-43.9508	-20.00	PASS
4500.2500	-44.6334	-20.00	PASS	



### Phase II: 450.025 MHz, 12.5.kHz Channel Spacing, Low. Power

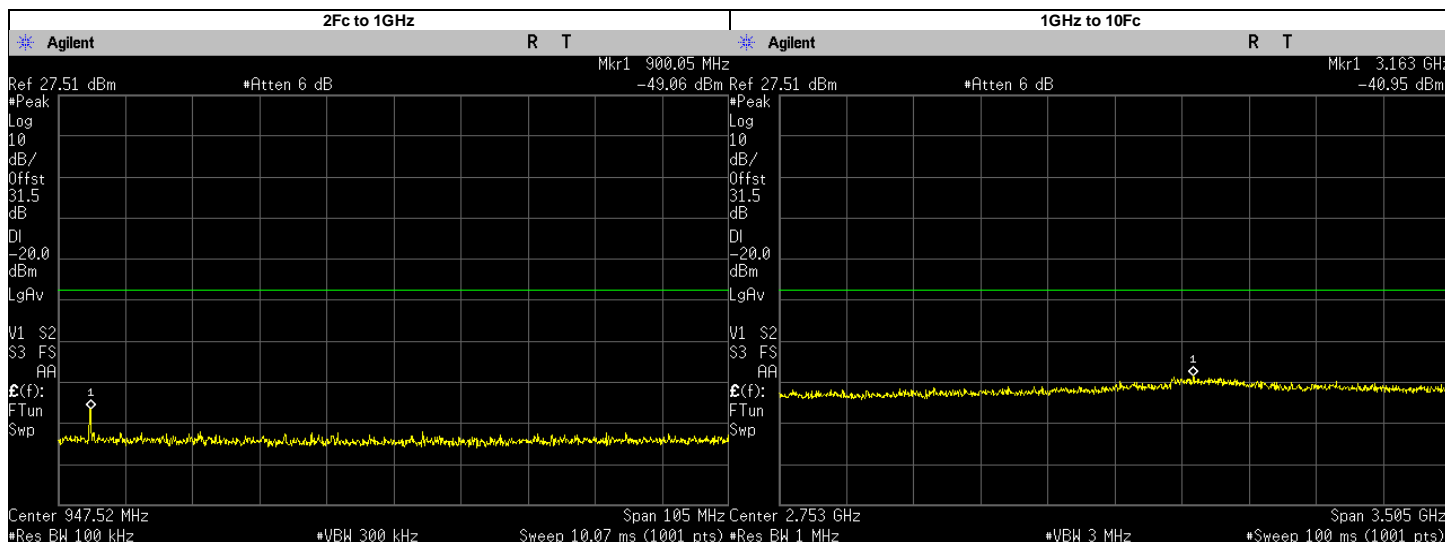
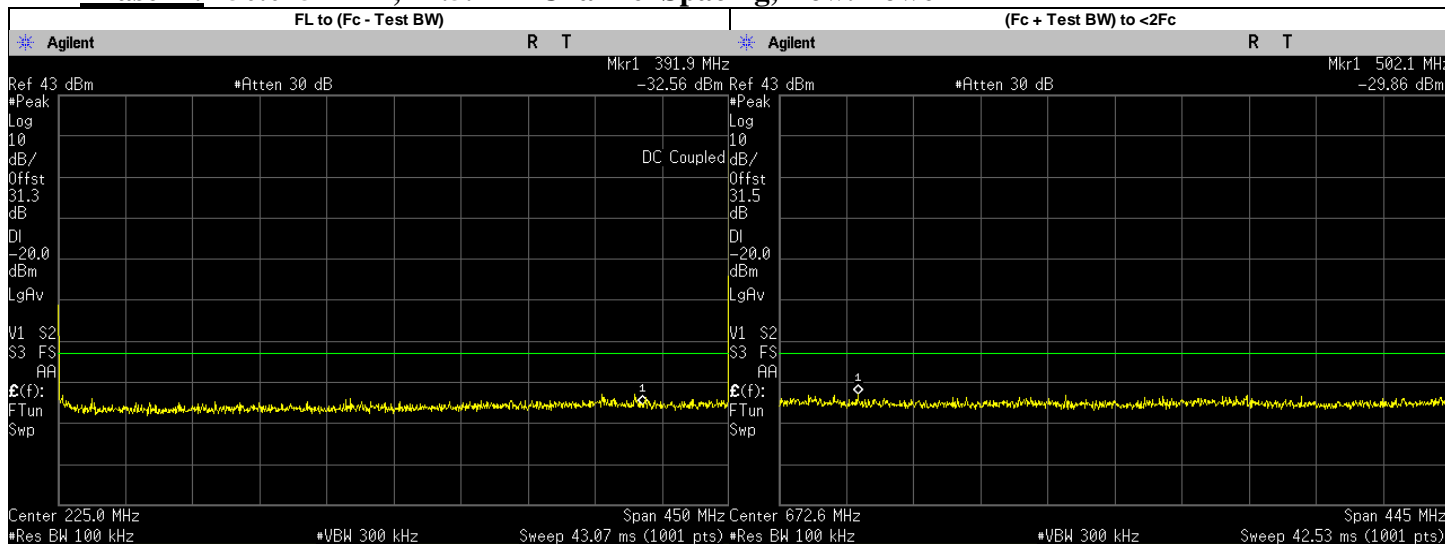

Frequency Range	Highest Spur Frequency (MHz)	Spurious Level (dBm)	Failing Limit (dBm)	Results
FL to (Fc - Test BW)	391.9000	-32.5610	-20.00	PASS
(Fc + Test BW) to <2Fc	502.1431	-29.8600	-20.00	PASS
2Fc to 1GHz 1GHz to 10Fc	900.0500	-49.0572	-20.00	PASS
	3162.7390	-40.9500	-20.00	PASS
	1350.0750	-46.1109	-20.00	PASS
	1800.1000	-44.5366	-20.00	PASS
	2250.1250	-45.2754	-20.00	PASS
	2700.1500	-43.7307	-20.00	PASS
	3150.1750	-42.3403	-20.00	PASS
	3600.2000	-42.7272	-20.00	PASS
	4050.2250	-44.1722	-20.00	PASS
4500.2500	-44.6975	-20.00	PASS	

**Phase II: 459.125 MHz, 12.5.kHz Channel Spacing, Max. Power**

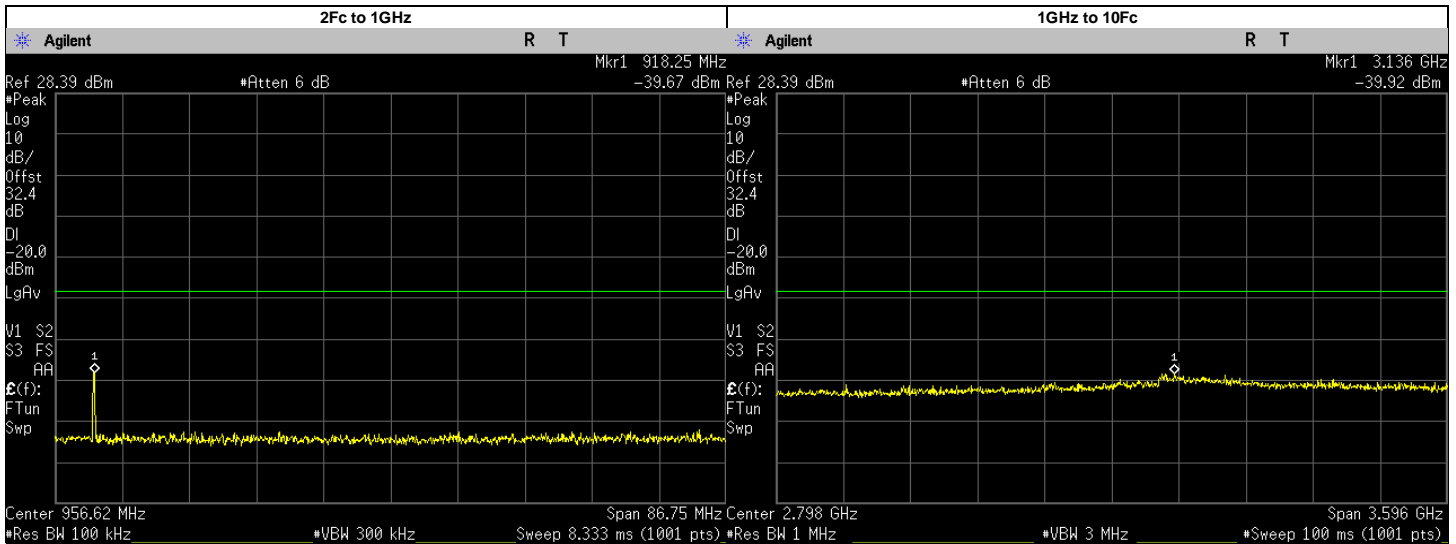
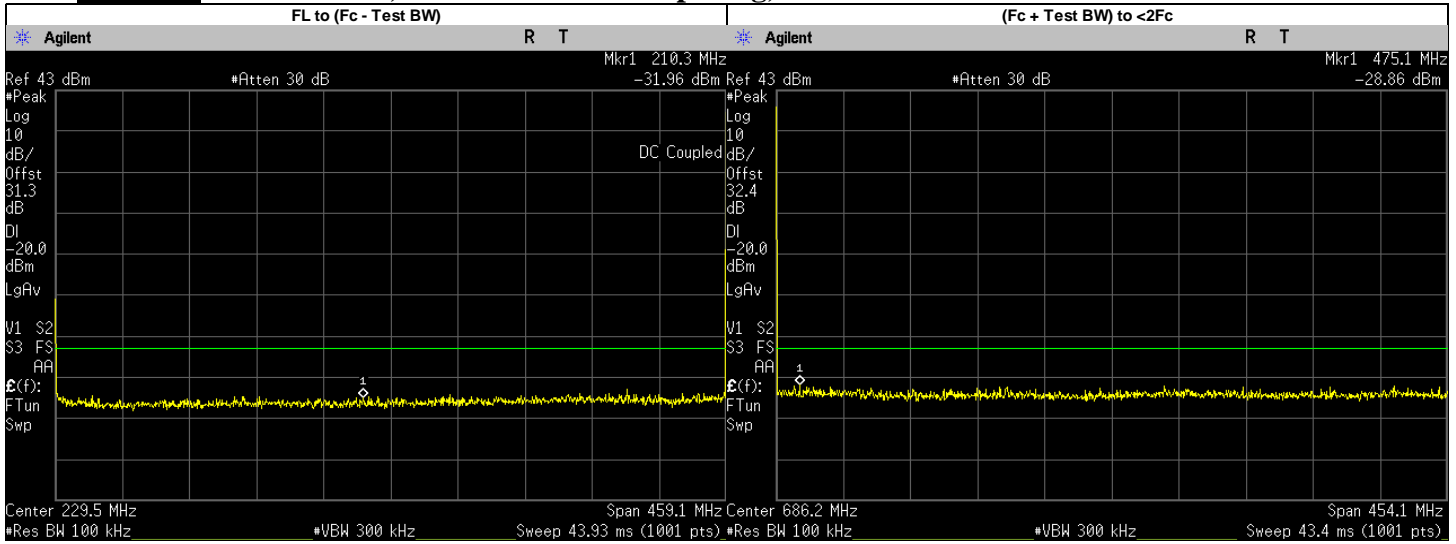

Frequency Range	Highest Spur Frequency (MHz)	Spurious Level (dBm)	Failing Limit (dBm)	Results
FL to (Fc - Test BW)	210.3000	-31.9630	-20.00	PASS
(Fc + Test BW) to <2Fc	475.0742	-28.8600	-20.00	PASS
2Fc to 1GHz 1GHz to 10Fc	918.2500	-39.6728	-20.00	PASS
	3136.1730	-39.9200	-20.00	PASS
	1377.3750	-42.6690	-20.00	PASS
	1836.5000	-43.3150	-20.00	PASS
	2295.6250	-43.9468	-20.00	PASS
	2754.7500	-42.4112	-20.00	PASS
	3213.8750	-41.6566	-20.00	PASS
	3673.0000	-42.3898	-20.00	PASS
	4132.1250	-42.6705	-20.00	PASS
4591.2500	-43.1776	-20.00	PASS	

**Phase II: 467.775 MHz, 12.5.kHz Channel Spacing, Max. Power**

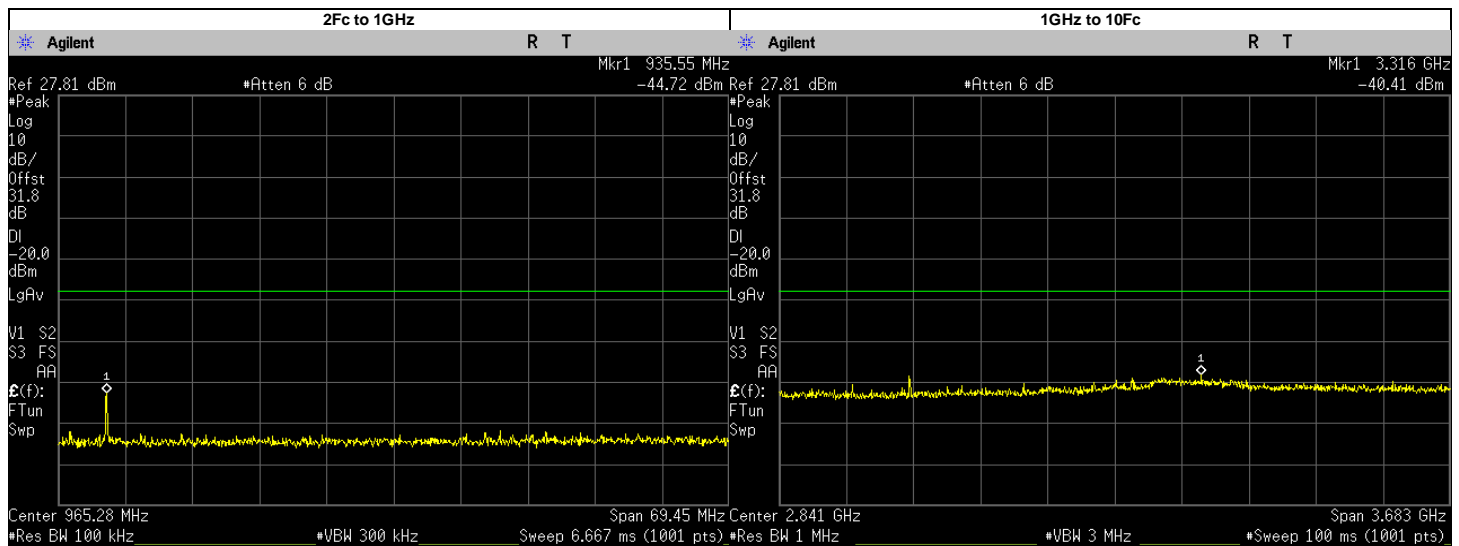
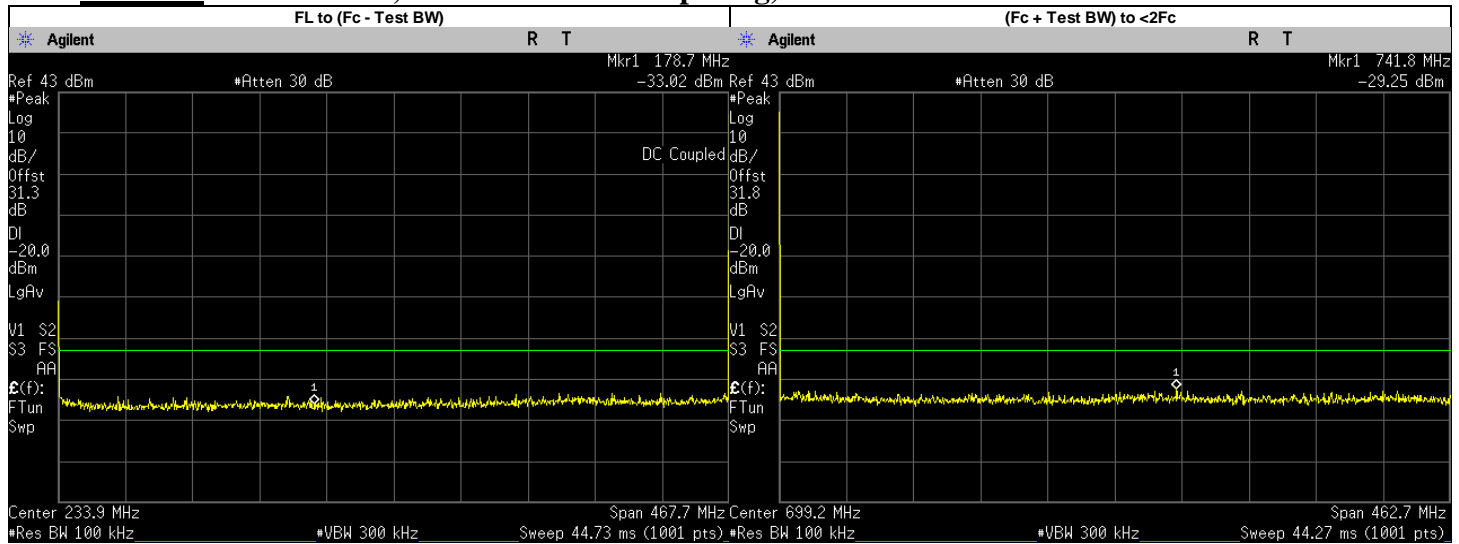

Frequency Range	Highest Spur Frequency (MHz)	Spurious Level (dBm)	Failing Limit (dBm)	Results
FL to (Fc - Test BW)	178.7000	-33.0240	-20.00	PASS
(Fc + Test BW) to <2Fc	741.7610	-29.2500	-20.00	PASS
2Fc to 1GHz 1GHz to 10Fc	935.5500	-44.7201	-20.00	PASS
	3316.4500	-40.4100	-20.00	PASS
	1403.3250	-43.1786	-20.00	PASS
	1871.1000	-45.3227	-20.00	PASS
	2338.8750	-43.1214	-20.00	PASS
	2806.6500	-43.5488	-20.00	PASS
	3274.4250	-42.0412	-20.00	PASS
	3742.2000	-43.5619	-20.00	PASS
	4209.9750	-42.9819	-20.00	PASS
4677.7500	-43.8689	-20.00	PASS	

### Phase II: 482.0125 MHz, 12.5.kHz Channel Spacing, Max. Power

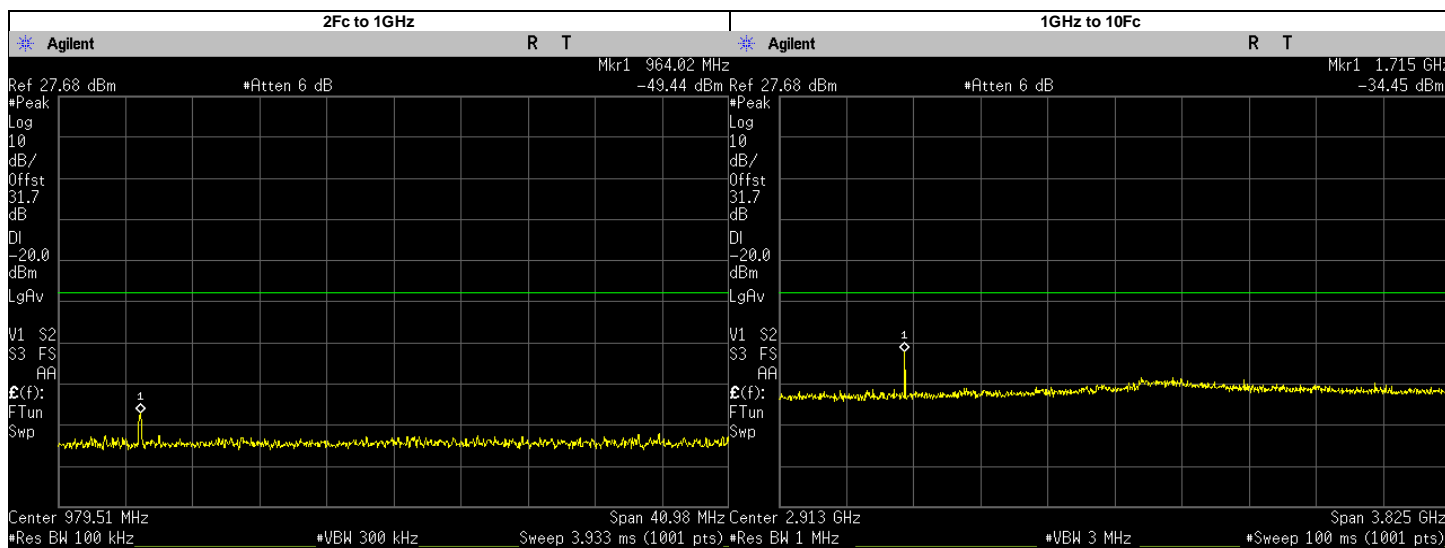
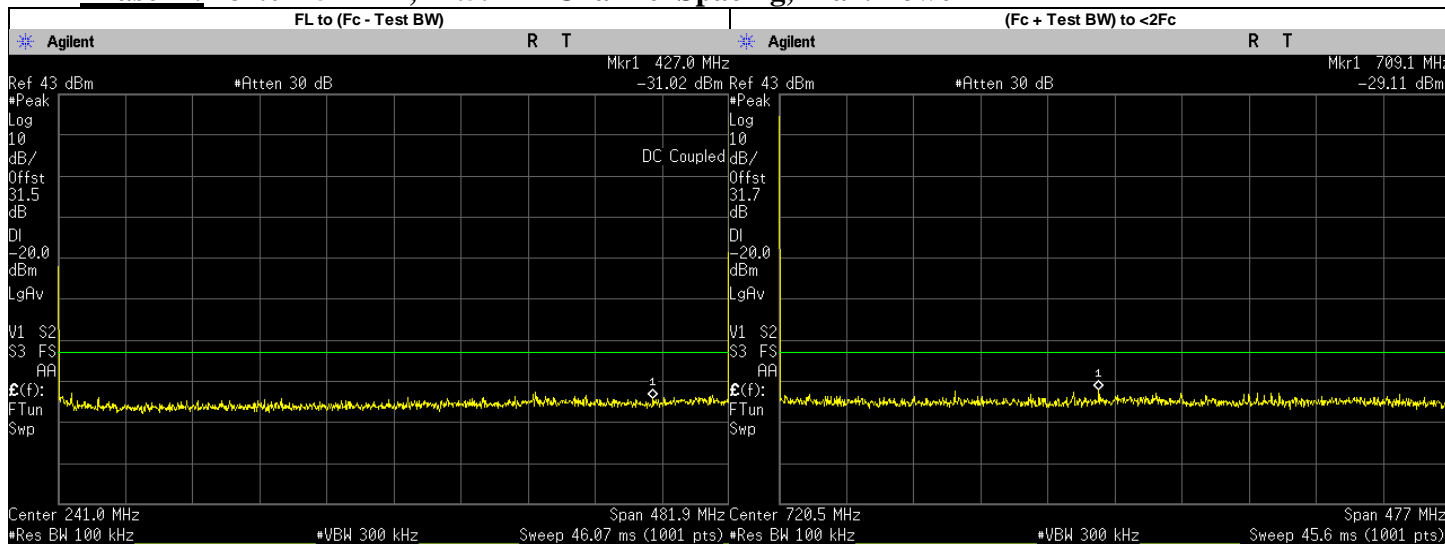

Frequency Range	Highest Spur Frequency (MHz)	Spurious Level (dBm)	Failing Limit (dBm)	Results
FL to (Fc - Test BW)	427.0000	-31.0220	-20.00	PASS
(Fc + Test BW) to <2Fc	709.1002	-29.1100	-20.00	PASS
2Fc to 1GHz 1GHz to 10Fc	964.0250	-49.4427	-20.00	PASS
	1715.2980	-34.4500	-20.00	PASS
	1446.0370	-44.8579	-20.00	PASS
	1928.0500	-45.4621	-20.00	PASS
	2410.0620	-44.3723	-20.00	PASS
	2892.0750	-43.8411	-20.00	PASS
	3374.0880	-42.6547	-20.00	PASS
	3856.1000	-43.7029	-20.00	PASS
	4338.1130	-44.1688	-20.00	PASS
4820.1250	-44.2356	-20.00	PASS	

**Phase II: 511.9875 MHz, 12.5.kHz Channel Spacing, Max. Power**

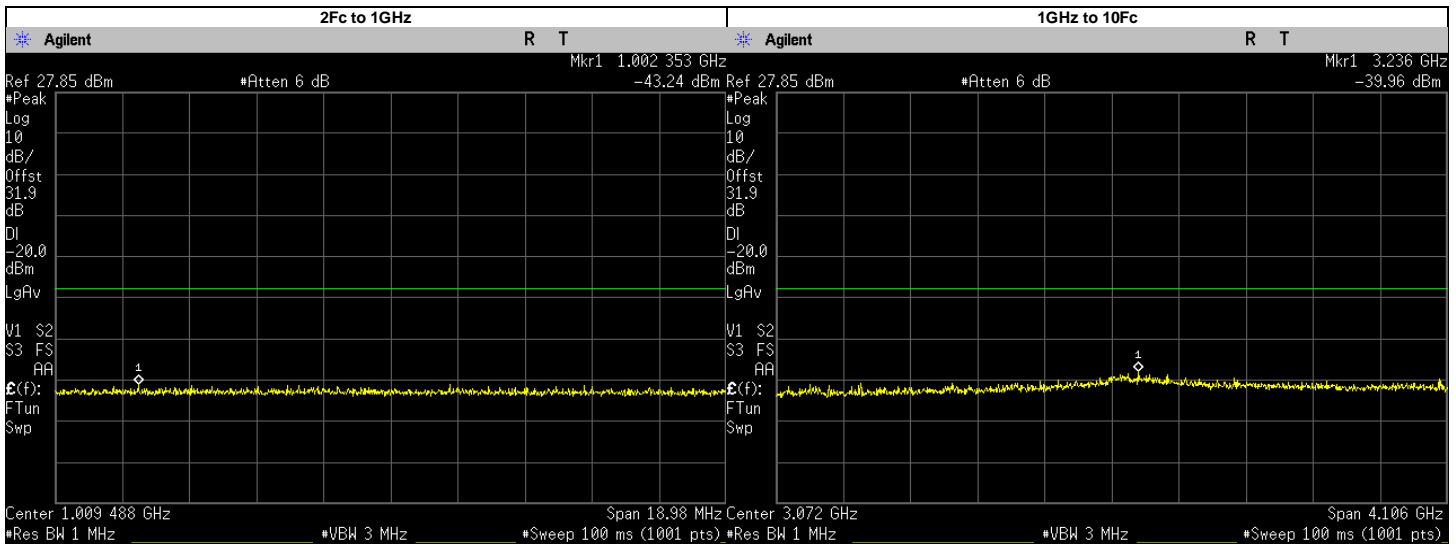
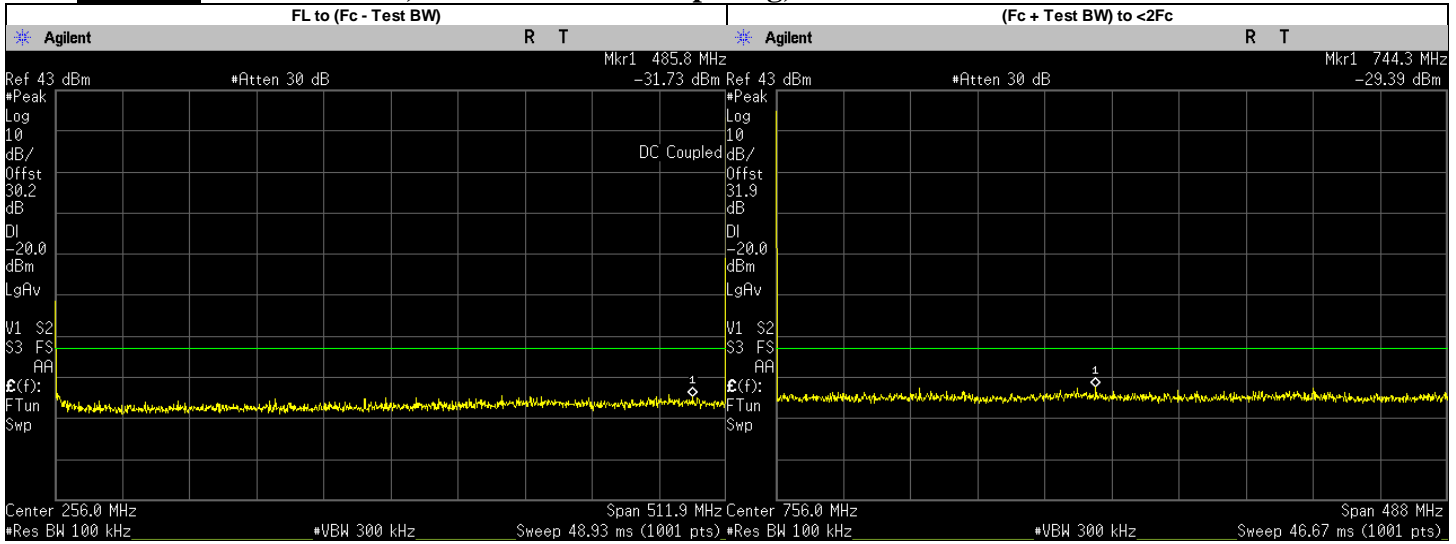

Frequency Range	Highest Spur Frequency (MHz)	Spurious Level (dBm)	Failing Limit (dBm)	Results
FL to (Fc - Test BW)	485.8000	-31.7340	-20.00	PASS
(Fc + Test BW) to <2Fc	744.3112	-29.3900	-20.00	PASS
2Fc to 1GHz 1GHz to 10Fc	1002.3530	-43.2400	-20.00	PASS
	3236.1610	-39.9600	-20.00	PASS
	1023.9750	-45.6455	-20.00	PASS
	1535.9630	-43.1584	-20.00	PASS
	2047.9500	-44.8910	-20.00	PASS
	2559.9370	-43.6286	-20.00	PASS
	3583.9120	-42.6009	-20.00	PASS
	4095.9000	-43.7246	-20.00	PASS
	4607.8870	-44.3917	-20.00	PASS
5119.8750	-44.4384	-20.00	PASS	

**Phase II: 511.9875 MHz, 12.5.kHz Channel Spacing, Low. Power**

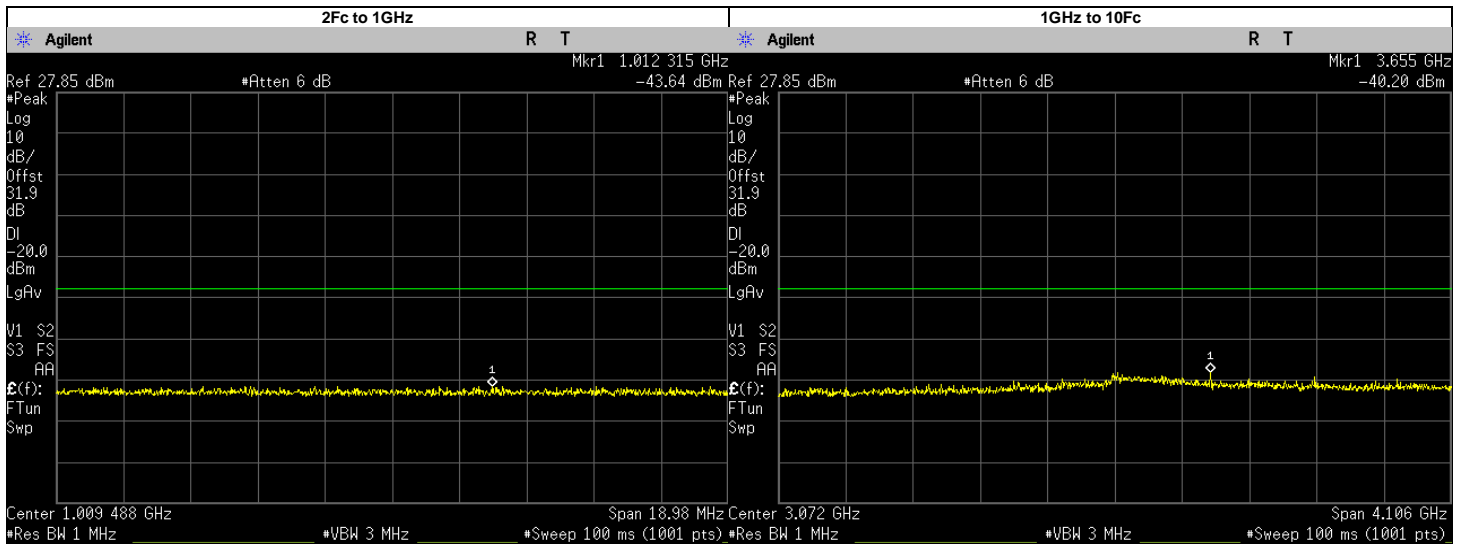
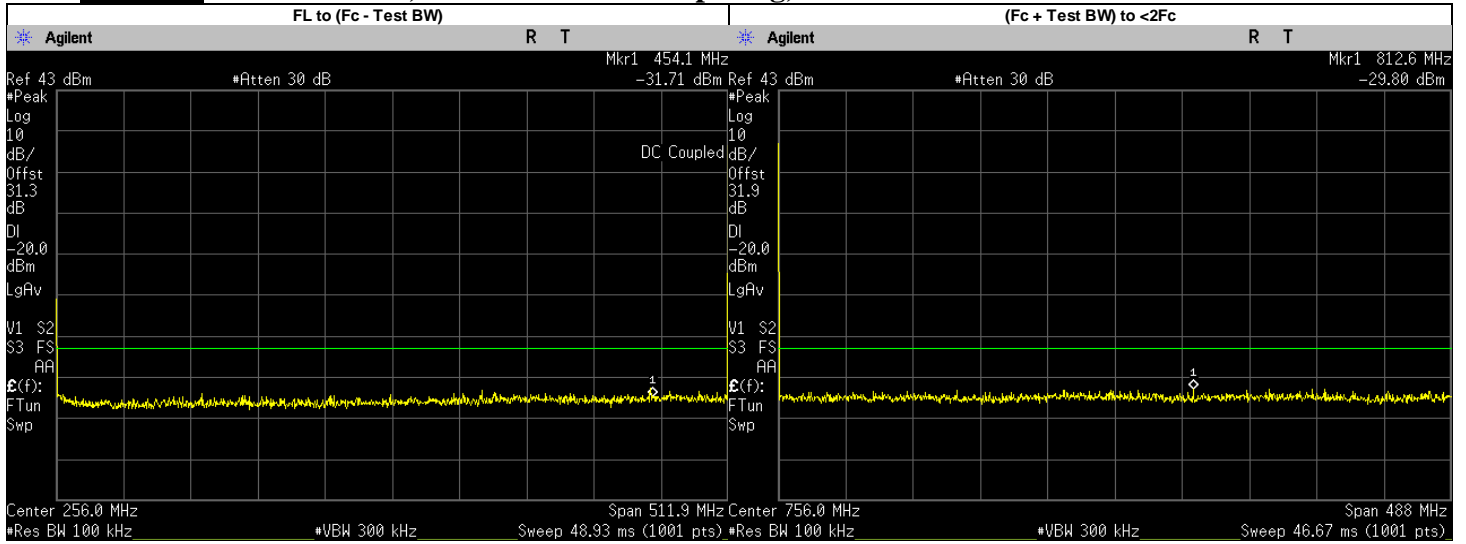

Frequency Range	Highest Spur Frequency (MHz)	Spurious Level (dBm)	Failing Limit (dBm)	Results
FL to (Fc - Test BW)	454.1000	-31.7110	-20.00	PASS
(Fc + Test BW) to <2Fc	812.6250	-29.8000	-20.00	PASS
2Fc to 1GHz 1GHz to 10Fc	1012.3150	-43.6400	-20.00	PASS
	3654.9630	-40.2000	-20.00	PASS
	1023.9750	-45.9003	-20.00	PASS
	1535.9630	-45.0423	-20.00	PASS
	2047.9500	-44.7503	-20.00	PASS
	2559.9370	-44.8416	-20.00	PASS
	3071.9250	-42.0560	-20.00	PASS
	4095.9000	-43.9941	-20.00	PASS
	4607.8870	-43.3659	-20.00	PASS
5119.8750	-44.2281	-20.00	PASS	

**Phase II: 519.9875 MHz, 12.5.kHz Channel Spacing, Max. Power**

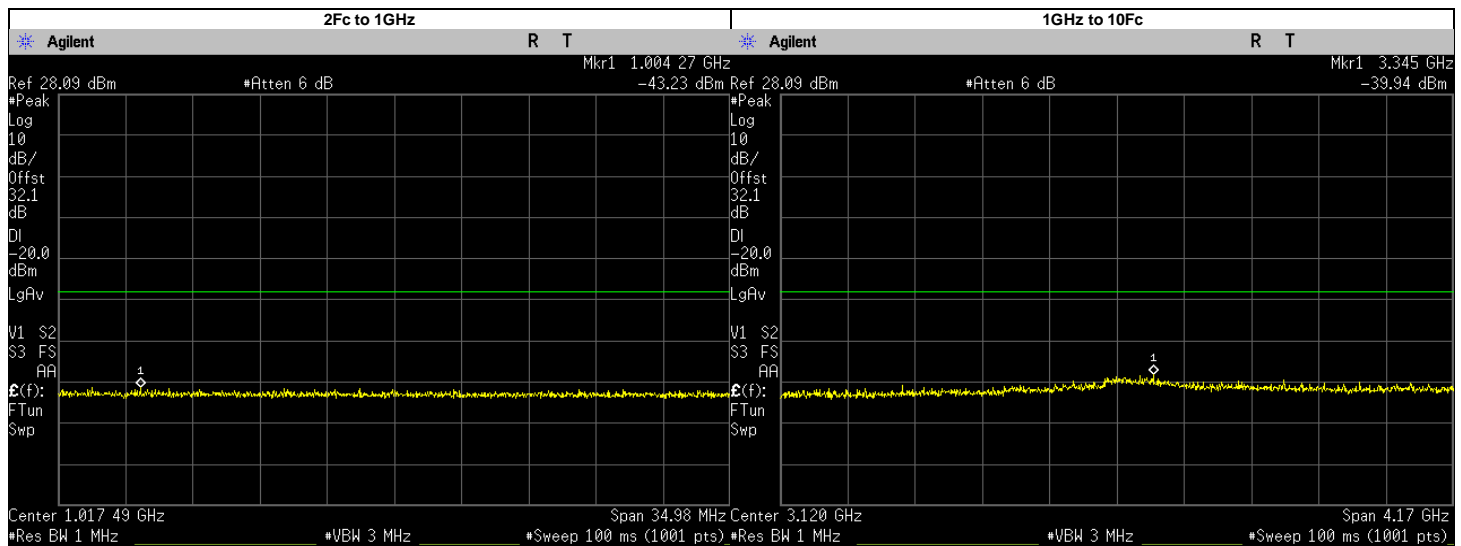
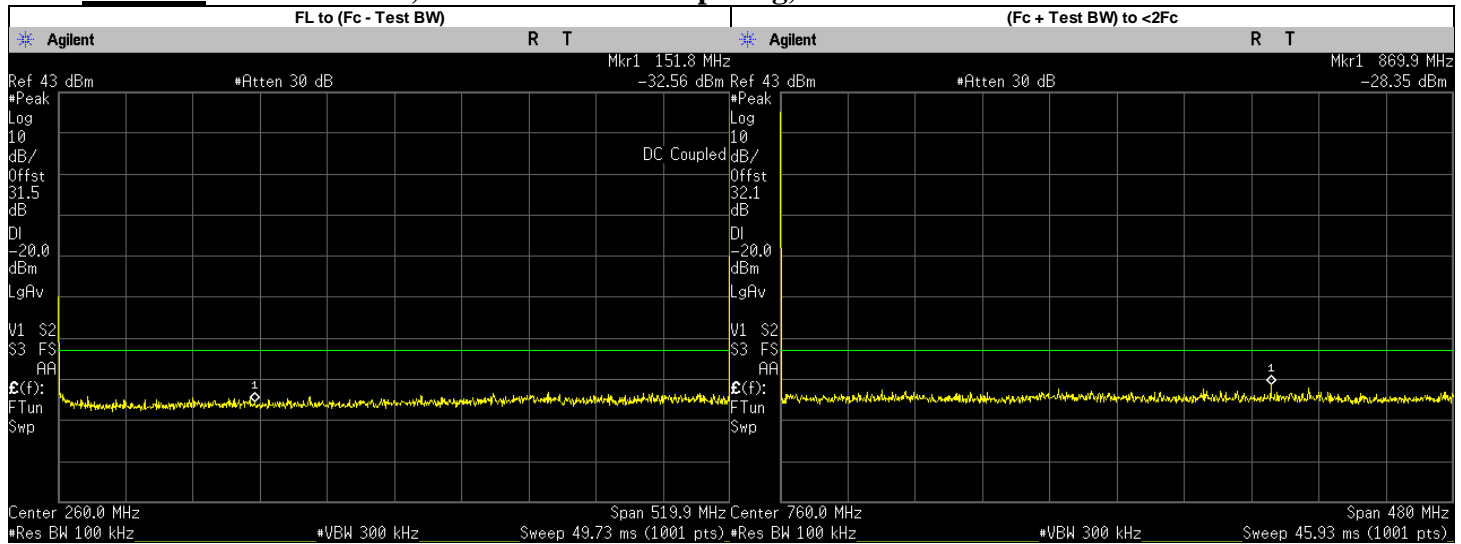

Frequency Range	Highest Spur Frequency (MHz)	Spurious Level (dBm)	Failing Limit (dBm)	Results
FL to (Fc - Test BW)	151.8000	-32.5600	-20.00	PASS
(Fc + Test BW) to <2Fc	869.9320	-28.3500	-20.00	PASS
2Fc to 1GHz 1GHz to 10Fc	1004.2670	-43.2300	-20.00	PASS
	3345.1000	-39.9400	-20.00	PASS
	1039.9750	-45.4333	-20.00	PASS
	1559.9630	-43.5279	-20.00	PASS
	2079.9500	-44.1655	-20.00	PASS
	2599.9370	-44.1272	-20.00	PASS
	3639.9120	-43.4350	-20.00	PASS
	4159.9000	-43.1831	-20.00	PASS
	4679.8870	-43.4816	-20.00	PASS
	5199.8750	-43.1629	-20.00	PASS

### 6.9.4. Test Limit

Table below summarized the power of any emission outside a licensee's frequency block shall be attenuated below the transmitter power (P) by at least

Channel Spacing	Part 22	Part 24D	Part 74	Part 80	Part 90 (UHF, VHF, 800, 900)	Part 90 (700)
12.5kHz	43 + log <sub>10</sub> (P) (-13 dBm)	43 + log <sub>10</sub> (P) (-13 dBm)	43 + log <sub>10</sub> (P) (-13 dBm)	Not Applicable	50 + log <sub>10</sub> (P) (-20 dBm)	43 + log <sub>10</sub> (P) (-13 dBm)
25kHz		Not Applicable		43 + log <sub>10</sub> (P) (-13 dBm)	43 + log <sub>10</sub> (P) (-13 dBm)	43 + log <sub>10</sub> (P) (-13 dBm)

Channel Spacing	RSS 134	RSS 182	RSS 119 (UHF, VHF, 800, 900)	RSS 119 (700)
12.5kHz	43 + log <sub>10</sub> (P) (-13 dBm)	Not Applicable	50 + log <sub>10</sub> (P) (-20 dBm)	43 + log <sub>10</sub> (P) (-13 dBm)
25kHz	Not Applicable	43 + log <sub>10</sub> (P) (-13 dBm)	43 + log <sub>10</sub> (P) (-13 dBm)	43 + log <sub>10</sub> (P) (-13 dBm)



## 6.10. Radiated Spurious Emission

### 6.10.1. Test Setup

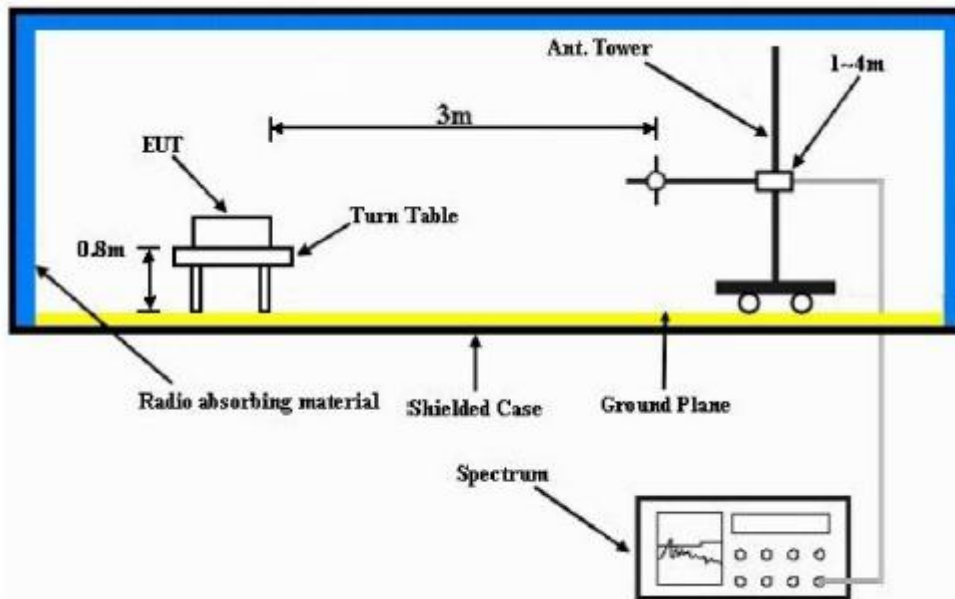

- 1) The Resolution Bandwidth for scanning Radiated Emission below 1 GHz is 100 kHz with Video Bandwidth = 300 kHz and Resolution Bandwidth for above 1 GHz is 1 MHz with Video Bandwidth = 3 MHz. Detector mode is positive peak.
- 2) In the semi- anechoic chamber, setup as illustrated above the DUT placed on the 0.8m height (for  $F_c < 1\text{GHz}$ ) or 1.5m height (for  $F_c > 1\text{GHz}$ ) of Turn Table, rotated the table around 360 degrees to search the maximum radiation power and receiver antenna shall be rotated vertical and horizontal polarization and moved height from 1m to 4m to find the maximum polar radiated power. The “Read Value” is the spectrum reading the maximum power value.
- 3) The substitution antenna is substituted for DUT at the same position and signals generator (S.G) export the CW signal to the substitution antenna via a TX cable. The receiver antenna shall be rotated vertical and horizontal polarization and moved height from 1m to 4m to find the maximum radiation power. Record the power level of maximum radiation power from spectrum. So, the measured substitution value = Ref level of S.G + TX cables loss – Substituted Antenna Gain.
- 4) Final Radiated Spurious Emission = “Read Value” + Measured substitution value.

### 6.10.2. Test Result (Analog)

SAC Transmitter Radiated Emission:

Model Number: H25XDF9PW6AN

S/N: 287TZP0060

SR:39809-EMC-00045

Battery Part No: PMNN4813A

Accy Part No: NA

380.012500 MHz

Test Mode: TX Analog  
 25 kHz

5.700 Watt(s) /Max Power

Frequency (MHz)	Limit	Horizontal Measured Emission Equiv Pwr Into Ideal Dipole (dBm)	Vertical Measured Emission Equiv Pwr Into ideal Dipole (dBm)
760.0250	-13.0000	-77.1083 **	-76.9501 **
1140.0375	-13.0000	-61.6312 **	-61.3938 **
1520.0500	-13.0000	-60.0183 **	-61.0554 **
1900.0625	-13.0000	-58.1533 **	-57.5332 **
2280.0750	-13.0000	-56.6841 **	-57.2731 **
2660.0875	-13.0000	-54.1951 **	-54.0535 **
3040.1000	-13.0000	-52.4808 **	-52.8857 **
3420.1125	-13.0000	-51.9613 **	-51.3097 **
3800.1250	-13.0000	-51.8841 **	-51.4782 **

RADIATED SPURIOUS EMISSIONS

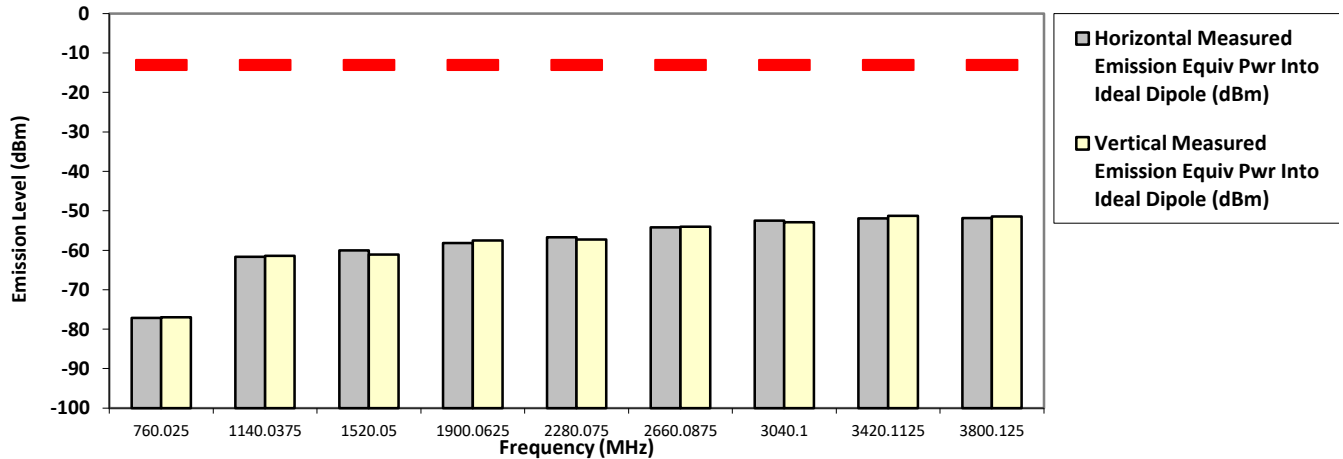

The data presented here was taken using the substitution method as found in the ANSI C63.26-2015 document.  
 Motorola Penang EMC Lab - Test Performed by: Nazrin & Rezza  
 Fri, 11 Aug, 2023

Remarks: \*\* Indicates the spurious emission could not be detected due to noise limitations or ambient.  
 \*Pursuant to CFR 47 Part 2.1057 ( c ), emissions attenuated more than 20 dB below the permissible limit are not reported  
 Temp(Deg): 23.4 Hum(%RH): 69.6

Remarks: Passed Results Marginal Results Failed Results

**SAC Transmitter Radiated Emission:**

Model Number: H25XDF9PW6AN      S/N: 287TZP0060      SR:39809-EMC-00045  
 Battery Part No: PMNN4813A      Test Mode: TX Analog      Accy Part No: NA  
 406.20000 MHz      25 kHz      5.700 Watt(s) /Max Power

Frequency (MHz)	Limit	Horizontal Measured Emission Equiv Pwr Into Ideal Dipole (dBm)	Vertical Measured Emission Equiv Pwr Into ideal Dipole (dBm)
812.4000	-13.0000	-76.0748 **	-76.4523 **
1218.6000	-13.0000	-62.3507 **	-61.7460 **
1624.8000	-13.0000	-60.2572 **	-59.4083 **
2031.0000	-13.0000	-56.8626 **	-56.9143 **
2437.2000	-13.0000	-55.5875 **	-56.2441 **
2843.4000	-13.0000	-54.9245 **	-55.9007 **
3249.6000	-13.0000	-52.0203 **	-51.4405 **
3655.8000	-13.0000	-51.7761 **	-54.4617 **
4062.0000	-13.0000	-50.6365 **	-51.2869 **

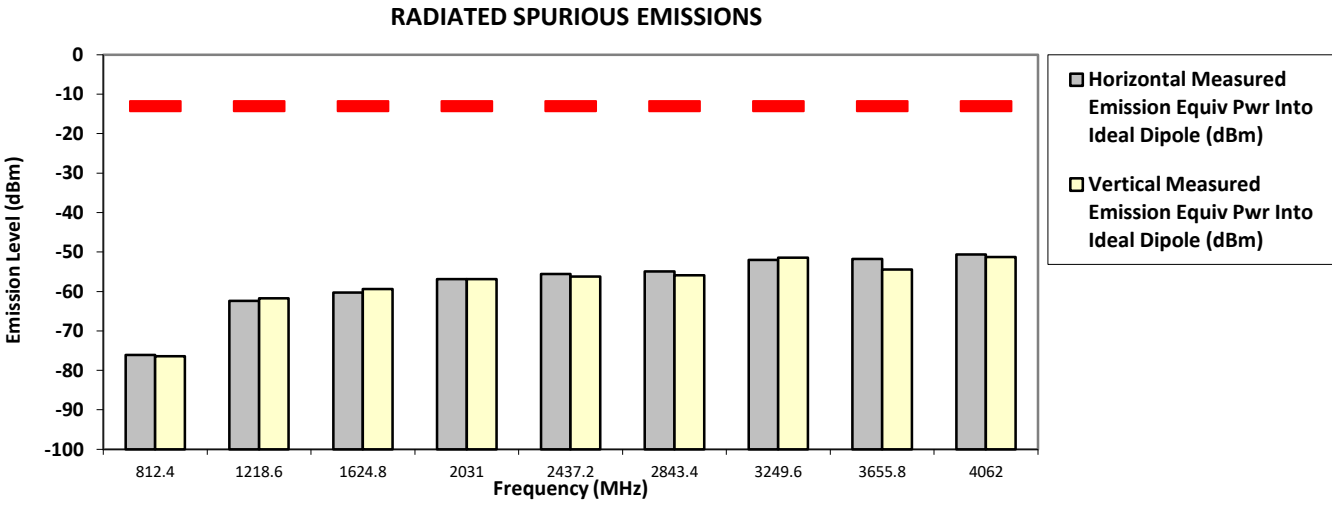

The data presented here was taken using the substitution method as found in the ANSI C63.26-2015 document.  
 Motorola Penang EMC Lab - Test Performed by: Nazrin & Rezza      Fri, 11 Aug, 2023

Remarks: \*\* Indicates the spurious emission could not be detected due to noise limitations or ambient.  
 \*Pursuant to CFR 47 Part 2.1057 ( c ), emissions attenuated more than 20 dB below the permissible limit are not reported  
 Temp(Deg): 23.4 Hum(%RH): 69.6

Remarks: Passed Results Marginal Results Failed Results

**SAC Transmitter Radiated Emission:**

**Model Number: H25XDF9PW6AN**      **S/N: 287TZP0060**      **SR:39809-EMC-00045**  
**Battery Part No: PMNN4813A**      **Accy Part No: NA**  
**450.025000 MHz**      **Test Mode: TX Analog**      **25 kHz**      **1.000 Watt(s) /Low Power**

Frequency (MHz)	Limit	Horizontal Measured Emission Equiv Pwr Into Ideal Dipole (dBm)	Vertical Measured Emission Equiv Pwr Into ideal Dipole (dBm)
900.0500	-13.0000	-76.7168 **	-75.1613 **
1350.0750	-13.0000	-61.1191 **	-58.0402 **
1800.1000	-13.0000	-59.2433 **	-59.0157 **
2250.1250	-13.0000	-56.6146 **	-56.8330 **
2700.1500	-13.0000	-53.6731 **	-54.1034 **
3150.1750	-13.0000	-51.1040 **	-52.5096 **
3600.2000	-13.0000	-53.2327 **	-52.8456 **
4050.2250	-13.0000	-51.3945 **	-50.4791 **
4500.2500	-13.0000	-50.1453 **	-49.8213 **

**RADIATED SPURIOUS EMISSIONS**

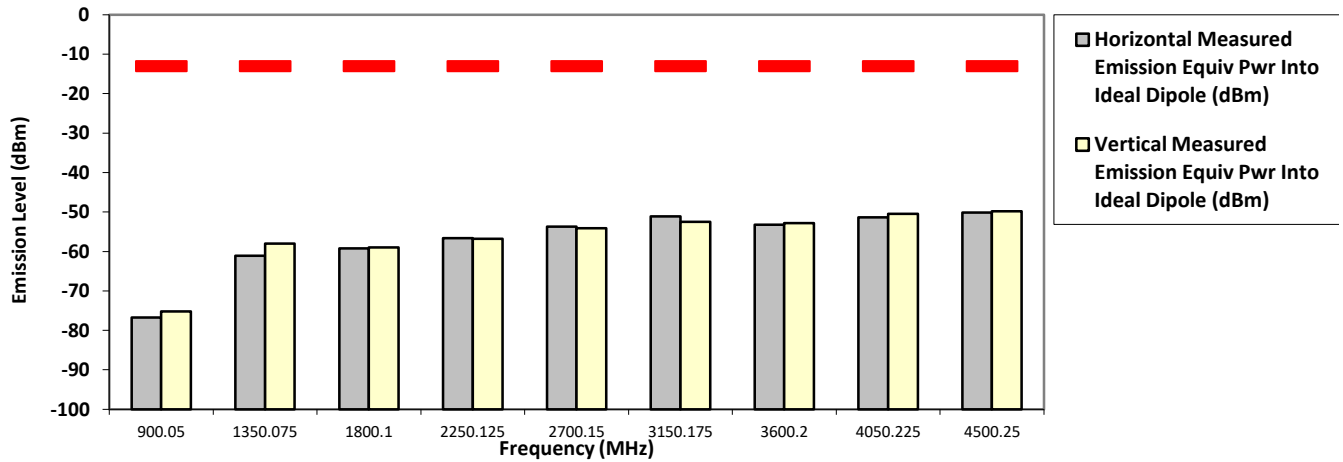

The data presented here was taken using the substitution method as found in the ANSI C63.26-2015 document.  
 Motorola Penang EMC Lab - Test Performed by: Nazrin & Rezza      Fri, 11 Aug, 2023

Remarks: \*\* Indicates the spurious emission could not be detected due to noise limitations or ambient.  
 \*Pursuant to CFR 47 Part 2.1057 ( c ), emissions attenuated more than 20 dB below the permissible limit are not reported  
 Temp(Deg): 23.4 Hum(%RH): 69.6

Remarks: Passed Results Marginal Results Failed Results

**SAC Transmitter Radiated Emission:**

**Model Number: H25XDF9PW6AN**      **S/N: 287TZP0060**      **SR:39809-EMC-00045**  
**Battery Part No: PMNN4813A**      **Accy Part No: NA**  
**450.025000 MHz**      **Test Mode: TX Analog**      **25 kHz**      **5.700 Watt(s) /Max Power**

Frequency (MHz)	Limit	Horizontal Measured Emission Equiv Pwr Into Ideal Dipole (dBm)	Vertical Measured Emission Equiv Pwr Into ideal Dipole (dBm)
900.0500	-13.0000	-76.6770 **	-75.8154 **
1350.0750	-13.0000	-56.4705 **	-60.4118 **
1800.1000	-13.0000	-60.0511 **	-58.7731 **
2250.1250	-13.0000	-57.2262 **	-56.9390 **
2700.1500	-13.0000	-54.2197 **	-54.0919 **
3150.1750	-13.0000	-51.2989 **	-52.5964 **
3600.2000	-13.0000	-52.1774 **	-52.8986 **
4050.2250	-13.0000	-50.4462 **	-50.8733 **
4500.2500	-13.0000	-50.7115 **	-50.5544 **

**RADIATED SPURIOUS EMISSIONS**

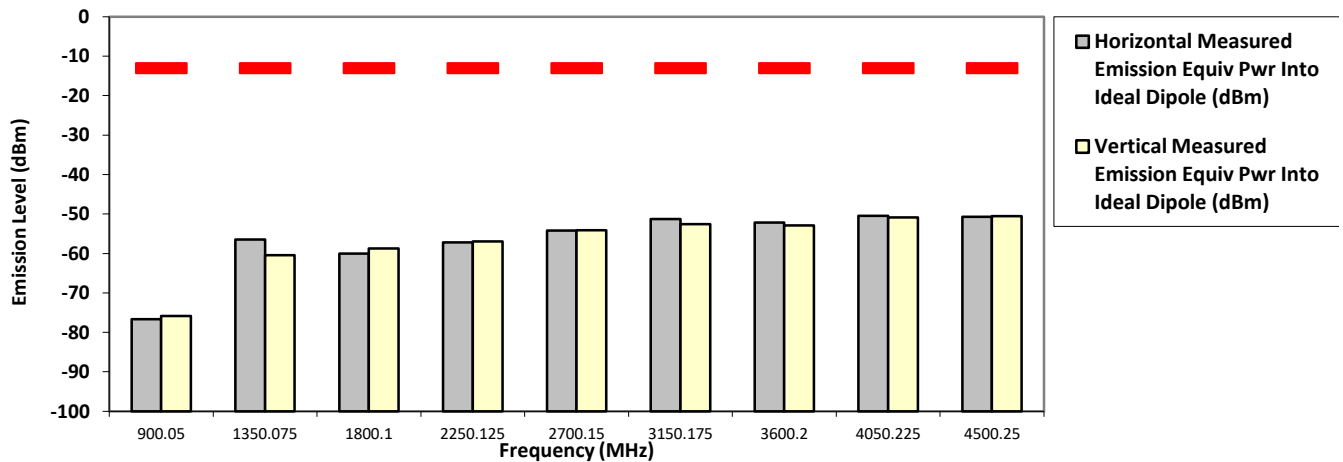

The data presented here was taken using the substitution method as found in the ANSI C63.26-2015 document.  
 Motorola Penang EMC Lab - Test Performed by: Nazrin & Rezza      Fri, 11 Aug, 2023

Remarks: \*\* Indicates the spurious emission could not be detected due to noise limitations or ambient.  
 \*Pursuant to CFR 47 Part 2.1057 ( c ), emissions attenuated more than 20 dB below the permissible limit are not reported  
 Temp(Deg): 23.4 Hum(%RH): 69.6

Remarks: Passed Results Marginal Results Failed Results

SAC Transmitter Radiated Emission:

Model Number: H25XDF9PW6AN

S/N: 287TZP0060

SR:39809-EMC-00045

Battery Part No: PMNN4813A

Accy Part No: NA

459.125000 MHz

Test Mode: TX Analog  
 25 kHz

5.700 Watt(s) /Max Power

Frequency (MHz)	Limit	Horizontal Measured Emission Equiv Pwr Into Ideal Dipole (dBm)	Vertical Measured Emission Equiv Pwr Into ideal Dipole (dBm)
918.2500	-13.0000	-76.0433 **	-76.3443 **
1377.3750	-13.0000	-61.0061 **	-59.7156 **
1836.5000	-13.0000	-59.0664 **	-58.4956 **
2295.6250	-13.0000	-57.4196 **	-56.4783 **
2754.7500	-13.0000	-55.5451 **	-55.3094 **
3213.8750	-13.0000	-52.3472 **	-52.3786 **
3673.0000	-13.0000	-52.8284 **	-52.6383 **
4132.1250	-13.0000	-50.9632 **	-50.8443 **
4591.2500	-13.0000	-50.1899 **	-49.0917 **

RADIATED SPURIOUS EMISSIONS

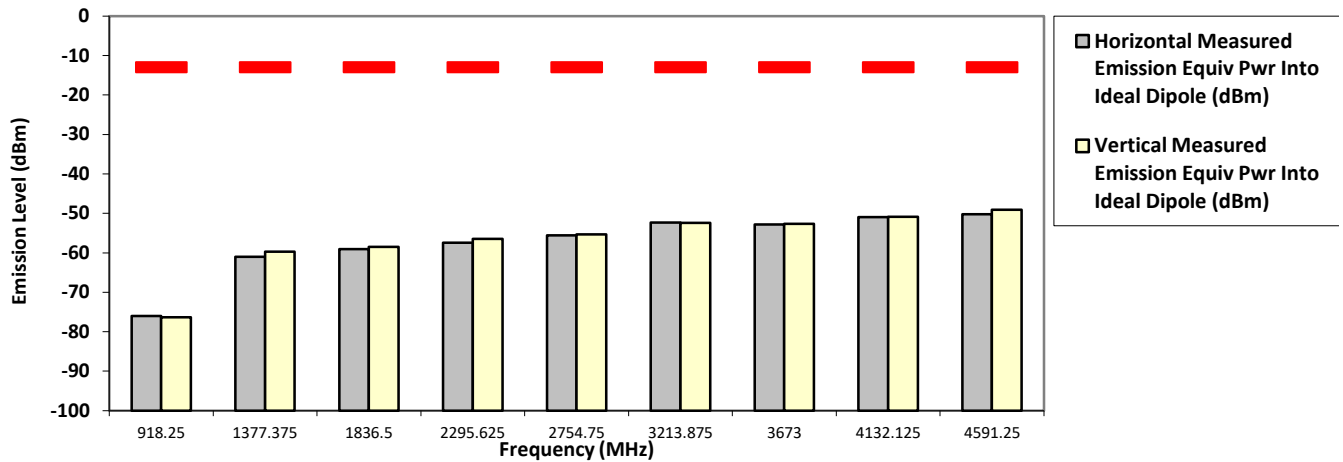

The data presented here was taken using the substitution method as found in the ANSI C63.26-2015 document.

Motorola Penang EMC Lab - Test Performed by: Nazrin & Rezza

Fri, 11 Aug, 2023

Remarks: \*\* Indicates the spurious emission could not be detected due to noise limitations or ambient.

\*Pursuant to CFR 47 Part 2.1057 ( c ), emissions attenuated more than 20 dB below the permissible limit are not reported

Temp(Deg): 23.4 Hum(%RH): 69.6

Remarks:

Passed Results	Marginal Results	Failed Results
----------------	------------------	----------------

**SAC Transmitter Radiated Emission:**

**Model Number: H25XDF9PW6AN**      **S/N: 287TZP0060**      **SR:39809-EMC-00045**  
**Battery Part No: PMNN4813A**      **Accy Part No: NA**  
**467.775000 MHz**      **Test Mode: TX Analog**      **25 kHz**      **1.000 Watt(s) /Low Power**

Frequency (MHz)	Limit	Horizontal Measured Emission Equiv Pwr Into Ideal Dipole (dBm)	Vertical Measured Emission Equiv Pwr Into ideal Dipole (dBm)
935.5500	-13.0000	-75.8419 **	-73.9464 **
1403.3250	-13.0000	-61.0706 **	-60.3931 **
1871.1000	-13.0000	-58.0489 **	-58.3044 **
2338.8750	-13.0000	-55.7708 **	-55.8772 **
2806.6500	-13.0000	-55.0953 **	-54.9080 **
3274.4250	-13.0000	-52.8523 **	-52.4915 **
3742.2000	-13.0000	-52.4160 **	-52.3297 **
4209.9750	-13.0000	-51.6892 **	-50.9449 **
4677.7500	-13.0000	-48.9606 **	-49.1758 **

**RADIATED SPURIOUS EMISSIONS**

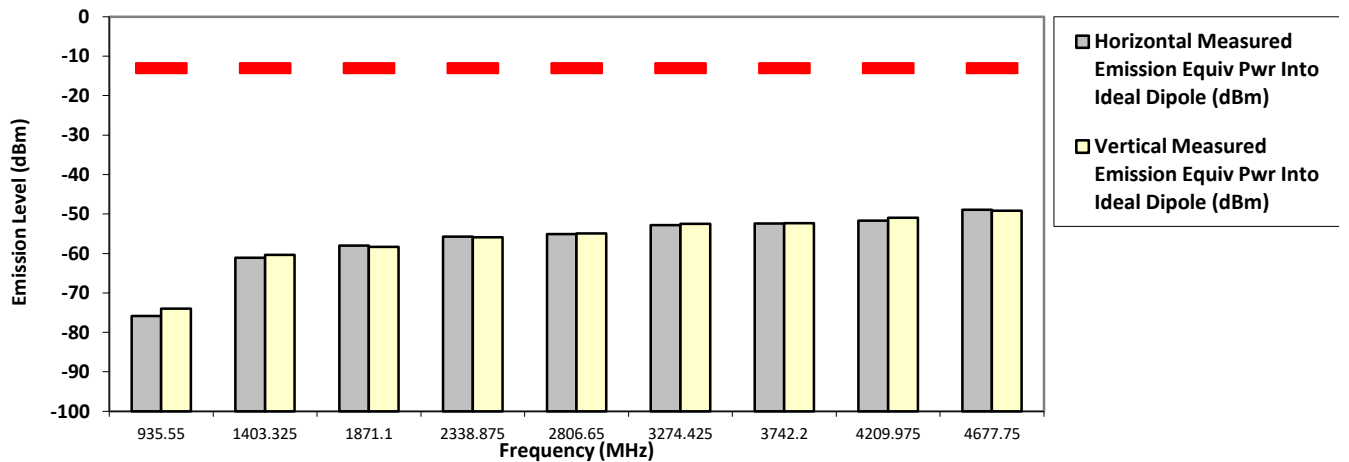

The data presented here was taken using the substitution method as found in the ANSI C63.26-2015 document.  
 Motorola Penang EMC Lab - Test Performed by: Nazrin & Rezza      Fri, 11 Aug, 2023

Remarks: \*\* Indicates the spurious emission could not be detected due to noise limitations or ambient.  
 \*Pursuant to CFR 47 Part 2.1057 ( c ), emissions attenuated more than 20 dB below the permissible limit are not reported  
 Temp(Deg): 23.4 Hum(%RH): 69.6

Remarks: Passed Results Marginal Results Failed Results

**SAC Transmitter Radiated Emission:**

**Model Number: H25XDF9PW6AN**      **S/N: 287TZP0060**      **SR:39809-EMC-00045**  
**Battery Part No: PMNN4813A**      **Test Mode: TX Analog**      **Accy Part No: NA**  
**467.775000 MHz**      **25 kHz**      **5.700 Watt(s) /Max Power**

Frequency (MHz)	Limit	Horizontal Measured Emission Equiv Pwr Into Ideal Dipole (dBm)	Vertical Measured Emission Equiv Pwr Into ideal Dipole (dBm)
935.5500	-13.0000	-76.1159 **	-76.2775 **
1403.3250	-13.0000	-61.5807 **	-59.9227 **
1871.1000	-13.0000	-58.7134 **	-58.2024 **
2338.8750	-13.0000	-56.4930 **	-55.9903 **
2806.6500	-13.0000	-55.9965 **	-55.3513 **
3274.4250	-13.0000	-53.1314 **	-51.8875 **
3742.2000	-13.0000	-52.8786 **	-51.7445 **
4209.9750	-13.0000	-51.1697 **	-50.9630 **
4677.7500	-13.0000	-49.9963 **	-49.1145 **

**RADIATED SPURIOUS EMISSIONS**

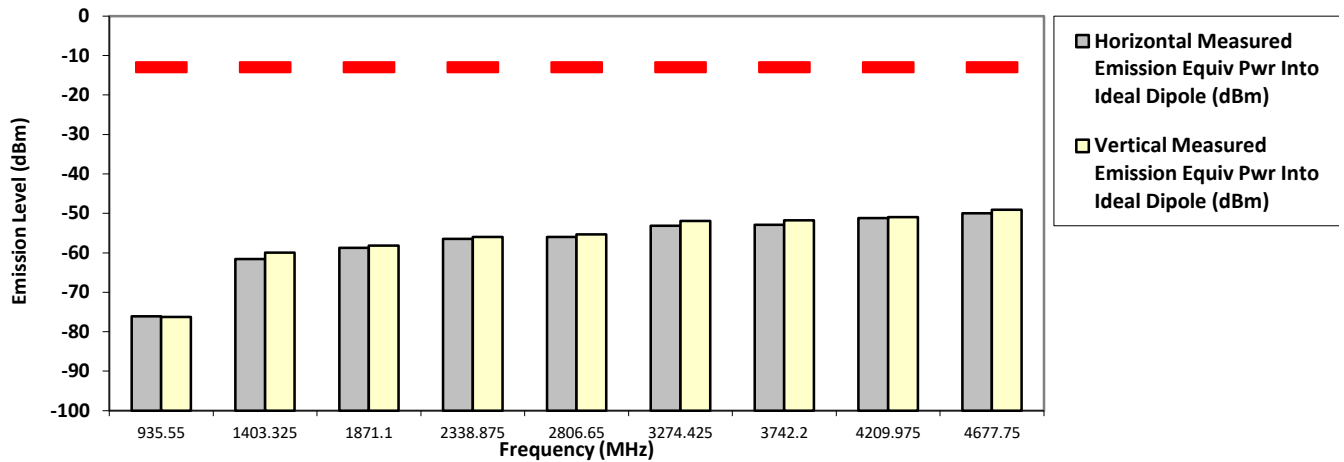

The data presented here was taken using the substitution method as found in the ANSI C63.26-2015 document.  
 Motorola Penang EMC Lab - Test Performed by: Nazrin & Rezza      Fri, 11 Aug, 2023

Remarks: \*\* Indicates the spurious emission could not be detected due to noise limitations or ambient.  
 \*Pursuant to CFR 47 Part 2.1057 ( c ), emissions attenuated more than 20 dB below the permissible limit are not reported  
 Temp(Deg): 23.4 Hum(%RH): 69.6

Remarks: Passed Results Marginal Results Failed Results



**SAC Transmitter Radiated Emission:**

**Model Number: H25XDF9PW6AN**      **S/N: 287TZP0060**      **SR:39809-EMC-00045**  
**Battery Part No: PMNN4813A**      **Test Mode: TX Analog**      **Accy Part No: NA**  
**482.012500 MHz**      **25 kHz**      **5.700 Watt(s) /Max Power**

Frequency (MHz)	Limit	Horizontal Measured Emission Equiv Pwr Into Ideal Dipole (dBm)	Vertical Measured Emission Equiv Pwr Into ideal Dipole (dBm)
964.0250	-13.0000	-75.2573 **	-74.2272 **
1446.0375	-13.0000	-60.6952 **	-61.1664 **
1928.0500	-13.0000	-57.7378 **	-57.4733 **
2410.0625	-13.0000	-53.7893 **	-55.1027 **
2892.0750	-13.0000	-53.3724 **	-54.8824 **
3374.0875	-13.0000	-52.6480 **	-50.5100 **
3856.1000	-13.0000	-51.5783 **	-50.5866 **
4338.1125	-13.0000	-51.4100 **	-50.4720 **
4820.1250	-13.0000	-48.2220 **	-48.9269 **

**RADIATED SPURIOUS EMISSIONS**

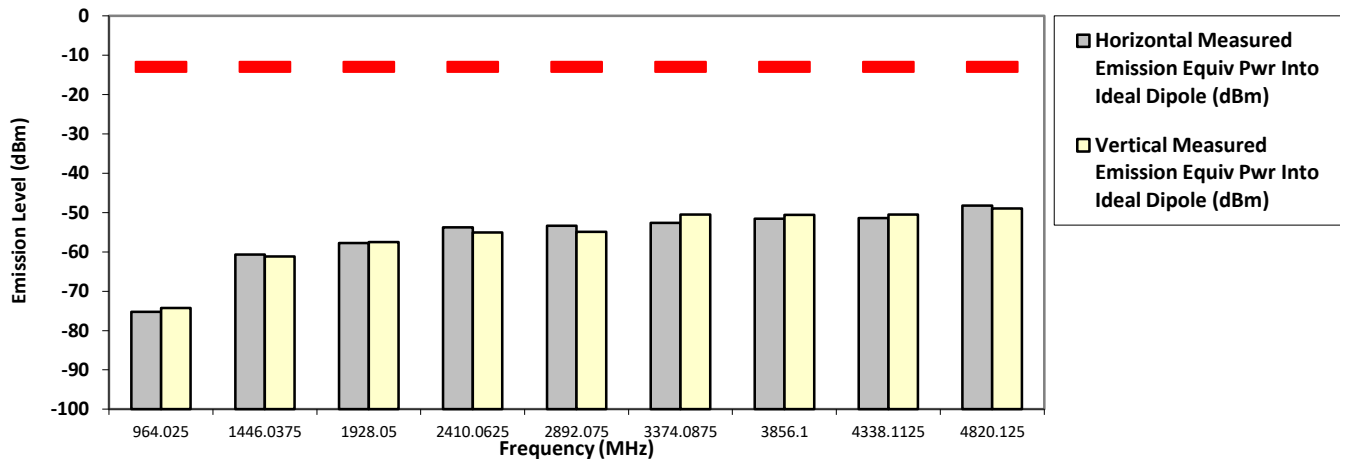

The data presented here was taken using the substitution method as found in the ANSI C63.26-2015 document.  
 Motorola Penang EMC Lab - Test Performed by: Nazrin & Rezza      Fri, 11 Aug, 2023

Remarks: \*\* Indicates the spurious emission could not be detected due to noise limitations or ambient.  
 \*Pursuant to CFR 47 Part 2.1057 ( c ), emissions attenuated more than 20 dB below the permissible limit are not reported  
 Temp(Deg): 23.4 Hum(%RH): 69.6

Remarks: Passed Results Marginal Results Failed Results

**SAC Transmitter Radiated Emission:**

**Model Number: H25XDF9PW6AN**      **S/N: 287TZP0060**      **SR:39809-EMC-00045**  
**Battery Part No: PMNN4813A**      **Test Mode: TX Analog**      **Accy Part No: NA**  
**511.987500 MHz**      **25 kHz**      **1.000 Watt(s) /Low Power**

Frequency (MHz)	Limit	Horizontal Measured Emission Equiv Pwr Into Ideal Dipole (dBm)	Vertical Measured Emission Equiv Pwr Into ideal Dipole (dBm)
1023.9750	-13.0000	-62.9449 **	-61.7311 **
1535.9625	-13.0000	-59.9799 **	-60.8383 **
2047.9500	-13.0000	-56.5666 **	-56.2118 **
2559.9375	-13.0000	-54.9581 **	-54.7521 **
3071.9250	-13.0000	-53.3584 **	-53.1924 **
3583.9125	-13.0000	-53.3357 **	-52.5518 **
4095.9000	-13.0000	-51.1138 **	-50.3955 **
4607.8875	-13.0000	-50.2532 **	-49.5831 **
5119.8750	-13.0000	-49.3993 **	-48.4356 **

**RADIATED SPURIOUS EMISSIONS**

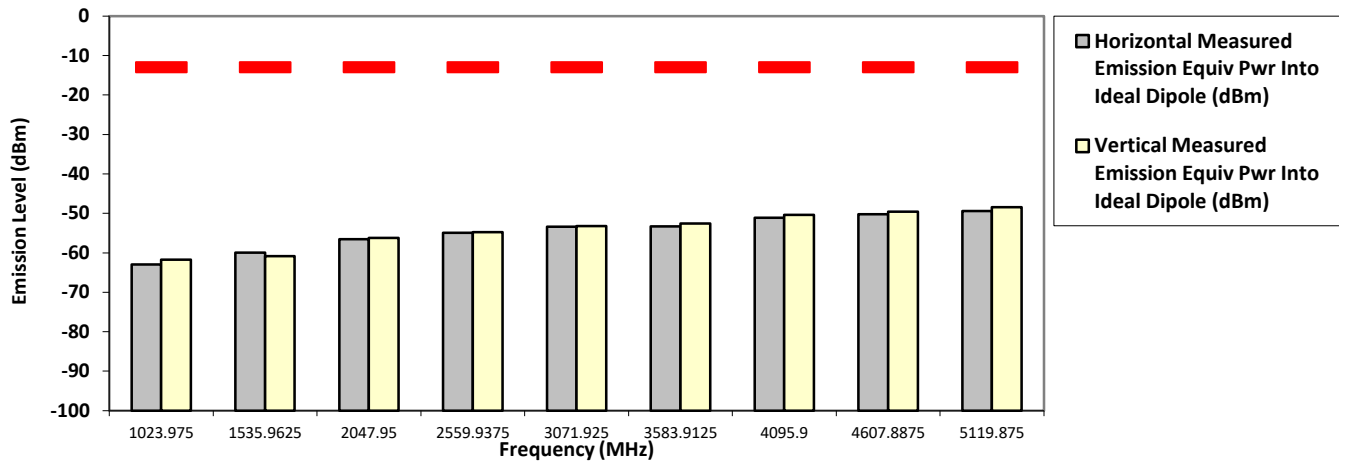

The data presented here was taken using the substitution method as found in the ANSI C63.26-2015 document.  
 Motorola Penang EMC Lab - Test Performed by: Nazrin & Rezza      Fri, 11 Aug, 2023

Remarks: \*\* Indicates the spurious emission could not be detected due to noise limitations or ambient.  
 \*Pursuant to CFR 47 Part 2.1057 ( c ), emissions attenuated more than 20 dB below the permissible limit are not reported  
 Temp(Deg): 23.4 Hum(%RH): 69.6

Remarks: Passed Results Marginal Results Failed Results

**SAC Transmitter Radiated Emission:**

**Model Number: H25XDF9PW6AN**      **S/N: 287TZP0060**      **SR:39809-EMC-00045**  
**Battery Part No: PMNN4813A**      **Test Mode: TX Analog**      **Accy Part No: NA**  
**511.987500 MHz**      **25 kHz**      **5.700 Watt(s) /Max Power**

Frequency (MHz)	Limit	Horizontal Measured Emission Equiv Pwr Into Ideal Dipole (dBm)	Vertical Measured Emission Equiv Pwr Into ideal Dipole (dBm)
1023.9750	-13.0000	-63.1450 **	-62.8269 **
1535.9625	-13.0000	-61.5806 **	-59.1794 **
2047.9500	-13.0000	-56.7672 **	-56.2276 **
2559.9375	-13.0000	-54.9738 **	-53.4798 **
3071.9250	-13.0000	-51.6938 **	-52.5832 **
3583.9125	-13.0000	-52.2106 **	-52.2958 **
4095.9000	-13.0000	-49.2567 **	-51.8146 **
4607.8875	-13.0000	-49.3442 **	-50.0372 **
5119.8750	-13.0000	-47.9986 **	-48.5101 **

**RADIATED SPURIOUS EMISSIONS**

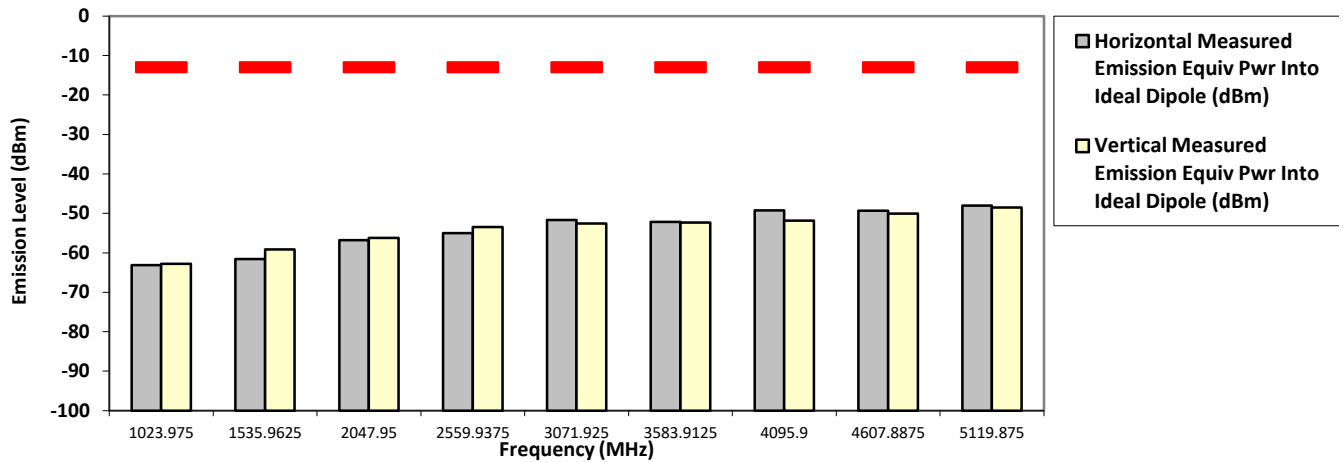

The data presented here was taken using the substitution method as found in the ANSI C63.26-2015 document.  
 Motorola Penang EMC Lab - Test Performed by: Nazrin & Rezza      Fri, 11 Aug, 2023

Remarks: \*\* Indicates the spurious emission could not be detected due to noise limitations or ambient.  
 \*Pursuant to CFR 47 Part 2.1057 ( c ), emissions attenuated more than 20 dB below the permissible limit are not reported  
 Temp(Deg): 23.4 Hum(%RH): 69.6

Remarks: Passed Results Marginal Results Failed Results

**SAC Transmitter Radiated Emission:**

**Model Number: H25XDF9PW6AN**      **S/N: 287TZP0060**      **SR:39809-EMC-00045**  
**Battery Part No: PMNN4813A**      **Test Mode: TX Analog**      **Accy Part No: NA**  
**519.987500 MHz**      **25 kHz**      **5.700 Watt(s) /Max Power**

Frequency (MHz)	Limit	Horizontal Measured Emission Equip Pwr Into Ideal Dipole (dBm)	Vertical Measured Emission Equip Pwr Into ideal Dipole (dBm)
1039.9750	-13.0000	-63.2215 **	-63.6652 **
1559.9625	-13.0000	-61.1018 **	-60.9350 **
2079.9500	-13.0000	-55.2756 **	-56.6980 **
2599.9375	-13.0000	-52.9749 **	-54.5307 **
3119.9250	-13.0000	-52.2407 **	-52.2989 **
3639.9125	-13.0000	-52.8176 **	-53.2976 **
4159.9000	-13.0000	-51.1479 **	-52.2071 **
4679.8875	-13.0000	-49.3979 **	-49.3024 **
5199.8750	-13.0000	-48.6579 **	-46.3473 **

**RADIATED SPURIOUS EMISSIONS**

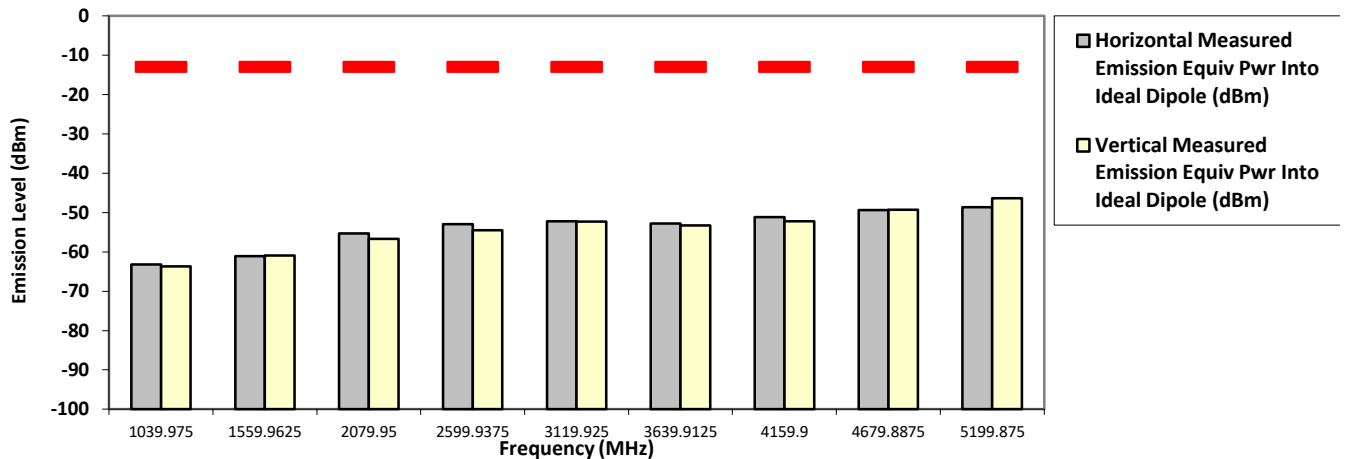

The data presented here was taken using the substitution method as found in the ANSI C63.26-2015 document.  
 Motorola Penang EMC Lab - Test Performed by: Nazrin & Rezza      Fri, 11 Aug, 2023

Remarks: \*\* Indicates the spurious emission could not be detected due to noise limitations or ambient.  
 \*Pursuant to CFR 47 Part 2.1057 ( c ), emissions attenuated more than 20 dB below the permissible limit are not reported  
 Temp(Deg): 23.4 Hum(%RH): 69.6

Remarks: Passed Results Marginal Results Failed Results

**SAC Transmitter Radiated Emission:**

**Model Number: H15XDF9PW6AN**      **S/N: 657TZP0033**      **SR:39809-EMC-00091**  
**Battery Part No: PMNN4813A**      **Test Mode: TX Analog**      **Accy Part No: NA**  
**380.012500 MHz**      **25 kHz**      **5.700 Watt(s) /Max Power**

Frequency (MHz)	Limit	Horizontal Measured Emission Equip Pwr Into Ideal Dipole (dBm)	Vertical Measured Emission Equip Pwr Into ideal Dipole (dBm)
760.0250	-13.0000	-76.9298 **	-76.5012 **
1140.0375	-13.0000	-61.6918 **	-60.1100 **
1520.0500	-13.0000	-59.4032 **	-59.7381 **
1900.0625	-13.0000	-57.5896 **	-56.6789 **
2280.0750	-13.0000	-56.1604 **	-54.4647 **
2660.0875	-13.0000	-54.4345 **	-54.3111 **
3040.1000	-13.0000	-52.0377 **	-52.6418 **
3420.1125	-13.0000	-51.5363 **	-52.1976 **
3800.1250	-13.0000	-51.6449 **	-50.3520 **

**RADIATED SPURIOUS EMISSIONS**

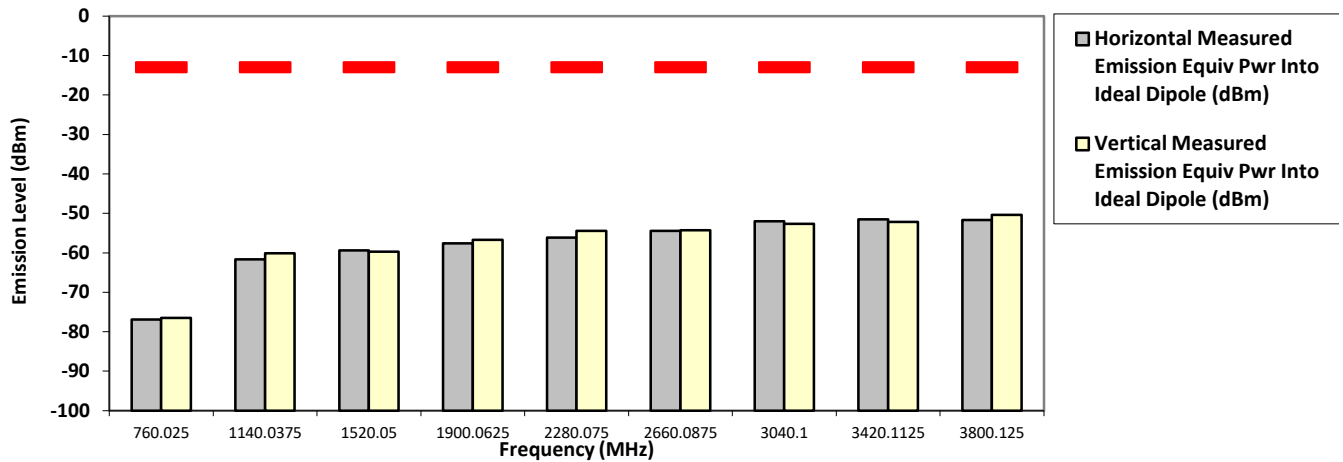

The data presented here was taken using the substitution method as found in the ANSI C63.26-2015 document.  
 Motorola Penang EMC Lab - Test Performed by: Nazrin & Rezza      Thu, 17 Aug, 2023

Remarks: \*\* Indicates the spurious emission could not be detected due to noise limitations or ambient.  
 \*Pursuant to CFR 47 Part 2.1057 ( c ), emissions attenuated more than 20 dB below the permissible limit are not reported  
 Temp(Deg): 23.4 Hum(%RH): 69.6

Remarks: Passed Results Marginal Results Failed Results

**SAC Transmitter Radiated Emission:**

**Model Number: H15XDF9PW6AN**      **S/N: 657TZP0033**      **SR:39809-EMC-00091**  
**Battery Part No: PMNN4813A**      **Test Mode: TX Analog**      **Accy Part No: NA**  
**406.20000 MHz**      **25 kHz**      **5.700 Watt(s) /Max Power**

Frequency (MHz)	Limit	Horizontal Measured Emission Equip Pwr Into Ideal Dipole (dBm)	Vertical Measured Emission Equip Pwr Into ideal Dipole (dBm)
812.4000	-13.0000	-75.5945 **	-75.6120 **
1218.6000	-13.0000	-60.9760 **	-61.7206 **
1624.8000	-13.0000	-59.4183 **	-58.7060 **
2031.0000	-13.0000	-55.4300 **	-56.0716 **
2437.2000	-13.0000	-55.3905 **	-55.4808 **
2843.4000	-13.0000	-54.2359 **	-53.9144 **
3249.6000	-13.0000	-50.1588 **	-52.2415 **
3655.8000	-13.0000	-53.0672 **	-52.4230 **
4062.0000	-13.0000	-50.5700 **	-50.4374 **

**RADIATED SPURIOUS EMISSIONS**

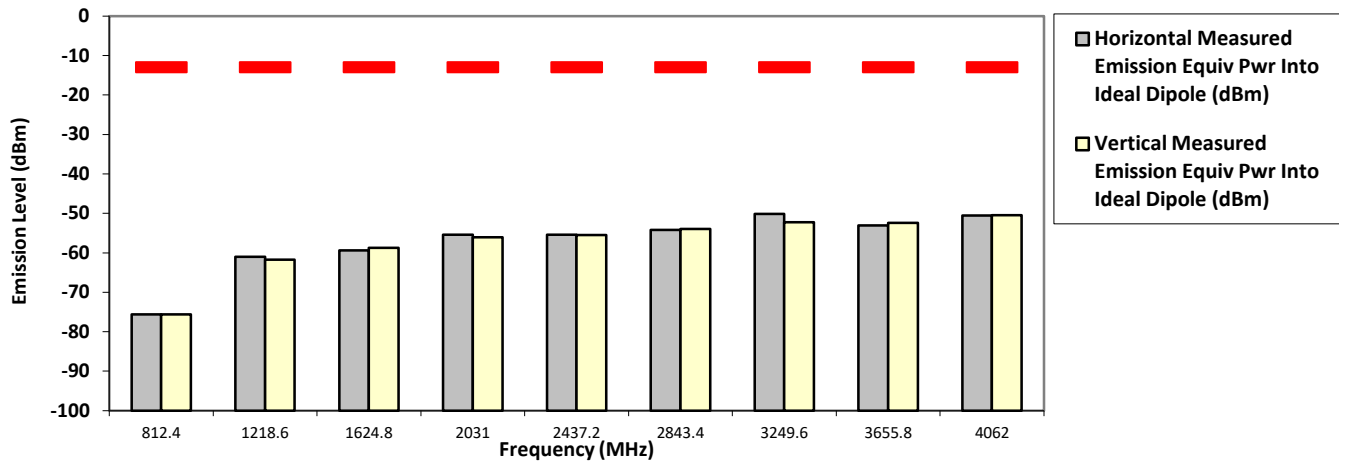

The data presented here was taken using the substitution method as found in the ANSI C63.26-2015 document.  
 Motorola Penang EMC Lab - Test Performed by: Nazrin & Rezza      Thu, 17 Aug, 2023

Remarks: \*\* Indicates the spurious emission could not be detected due to noise limitations or ambient.  
 \*Pursuant to CFR 47 Part 2.1057 ( c ), emissions attenuated more than 20 dB below the permissible limit are not reported  
 Temp(Deg): 23.4 Hum(%RH): 69.6

Remarks: Passed Results Marginal Results Failed Results

**SAC Transmitter Radiated Emission:**

**Model Number: H15XDF9PW6AN**      **S/N: 657TZP0033**      **SR:39809-EMC-00091**  
**Battery Part No: PMNN4813A**      **Test Mode: TX Analog**      **Accy Part No: NA**  
**450.025000 MHz**      **25 kHz**      **1.000 Watt(s) /Low Power**

Frequency (MHz)	Limit	Horizontal Measured Emission Equip Pwr Into Ideal Dipole (dBm)	Vertical Measured Emission Equip Pwr Into ideal Dipole (dBm)
900.0500	-13.0000	-75.8995 **	-74.5359 **
1350.0750	-13.0000	-60.6097 **	-60.4374 **
1800.1000	-13.0000	-58.6020 **	-58.1408 **
2250.1250	-13.0000	-55.4319 **	-56.3931 **
2700.1500	-13.0000	-53.7657 **	-54.1898 **
3150.1750	-13.0000	-53.2540 **	-52.0010 **
3600.2000	-13.0000	-52.8563 **	-52.9380 **
4050.2250	-13.0000	-50.2952 **	-51.3192 **
4500.2500	-13.0000	-49.2402 **	-49.2470 **

**RADIATED SPURIOUS EMISSIONS**

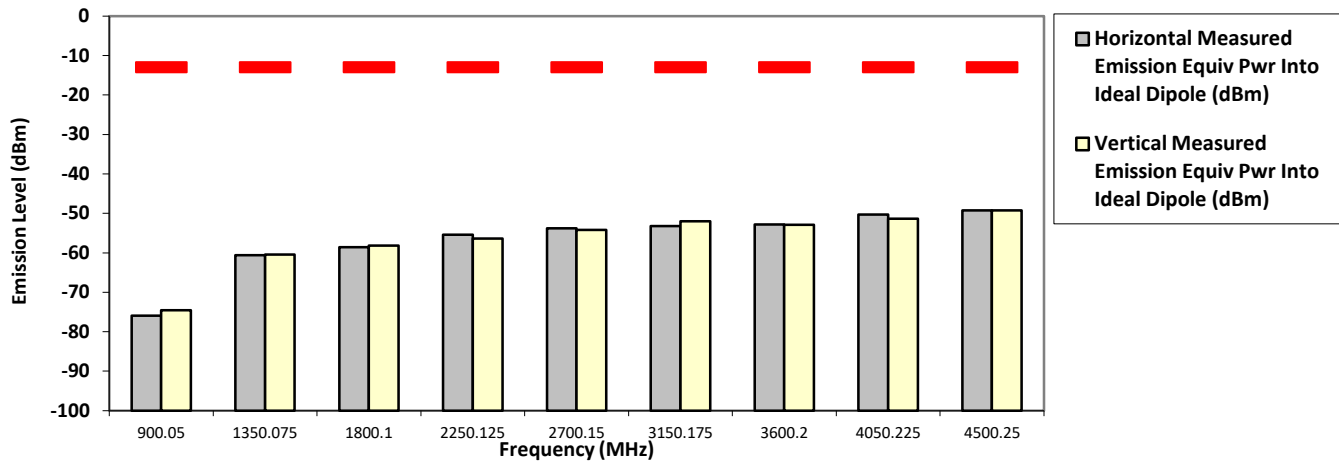

The data presented here was taken using the substitution method as found in the ANSI C63.26-2015 document.  
 Motorola Penang EMC Lab - Test Performed by: Nazrin & Rezza      Thu, 17 Aug, 2023

Remarks: \*\* Indicates the spurious emission could not be detected due to noise limitations or ambient.  
 \*Pursuant to CFR 47 Part 2.1057 ( c ), emissions attenuated more than 20 dB below the permissible limit are not reported  
 Temp(Deg): 23.4 Hum(%RH): 69.6

Remarks: Passed Results Marginal Results Failed Results

**SAC Transmitter Radiated Emission:**

**Model Number: H15XDF9PW6AN**      **S/N: 657TZP0033**      **SR:39809-EMC-00091**  
**Battery Part No: PMNN4813A**      **Test Mode: TX Analog**      **Accy Part No: NA**  
**450.025000 MHz**      **25 kHz**      **5.700 Watt(s) /Max Power**

Frequency (MHz)	Limit	Horizontal Measured Emission Equip Pwr Into Ideal Dipole (dBm)	Vertical Measured Emission Equip Pwr Into ideal Dipole (dBm)
900.0500	-13.0000	-74.8363 **	-75.6043 **
1350.0750	-13.0000	-60.9832 **	-59.9099 **
1800.1000	-13.0000	-58.1249 **	-58.8223 **
2250.1250	-13.0000	-56.4535 **	-54.9745 **
2700.1500	-13.0000	-54.3543 **	-54.1652 **
3150.1750	-13.0000	-51.8766 **	-52.0462 **
3600.2000	-13.0000	-52.1103 **	-52.7318 **
4050.2250	-13.0000	-49.9165 **	-50.1686 **
4500.2500	-13.0000	-49.6701 **	-49.9167 **

**RADIATED SPURIOUS EMISSIONS**

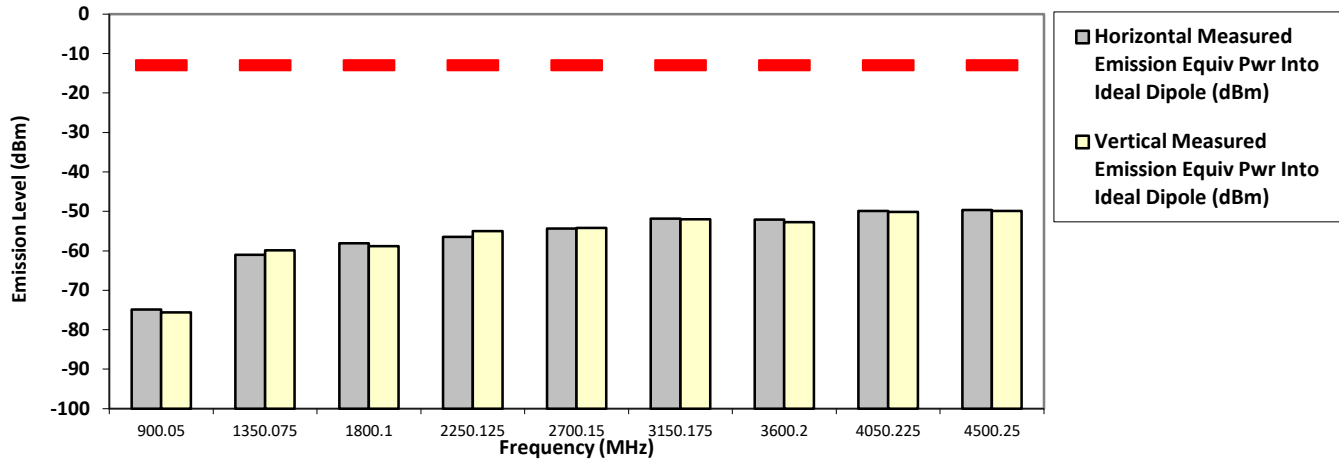

The data presented here was taken using the substitution method as found in the ANSI C63.26-2015 document.  
 Motorola Penang EMC Lab - Test Performed by: Nazrin & Rezza      Thu, 17 Aug, 2023

Remarks: \*\* Indicates the spurious emission could not be detected due to noise limitations or ambient.  
 \*Pursuant to CFR 47 Part 2.1057 ( c ), emissions attenuated more than 20 dB below the permissible limit are not reported  
 Temp(Deg): 23.4 Hum(%RH): 69.6

Remarks: Passed Results Marginal Results Failed Results



**SAC Transmitter Radiated Emission:**

**Model Number: H15XDF9PW6AN**      **S/N: 657TZP0033**      **SR:39809-EMC-00091**  
**Battery Part No: PMNN4813A**      **Test Mode: TX Analog**      **Accy Part No: NA**  
**459.125000 MHz**      **25 kHz**      **5.700 Watt(s) /Max Power**

Frequency (MHz)	Limit	Horizontal Measured Emission Equip Pwr Into Ideal Dipole (dBm)	Vertical Measured Emission Equip Pwr Into ideal Dipole (dBm)
918.2500	-13.0000	-76.6315 **	-76.2005 **
1377.3750	-13.0000	-60.7832 **	-60.7579 **
1836.5000	-13.0000	-58.3772 **	-57.4024 **
2295.6250	-13.0000	-56.2301 **	-56.4379 **
2754.7500	-13.0000	-53.6543 **	-53.4014 **
3213.8750	-13.0000	-50.9275 **	-50.4864 **
3673.0000	-13.0000	-52.6007 **	-51.5406 **
4132.1250	-13.0000	-50.9213 **	-51.1567 **
4591.2500	-13.0000	-49.1609 **	-48.9139 **

**RADIATED SPURIOUS EMISSIONS**

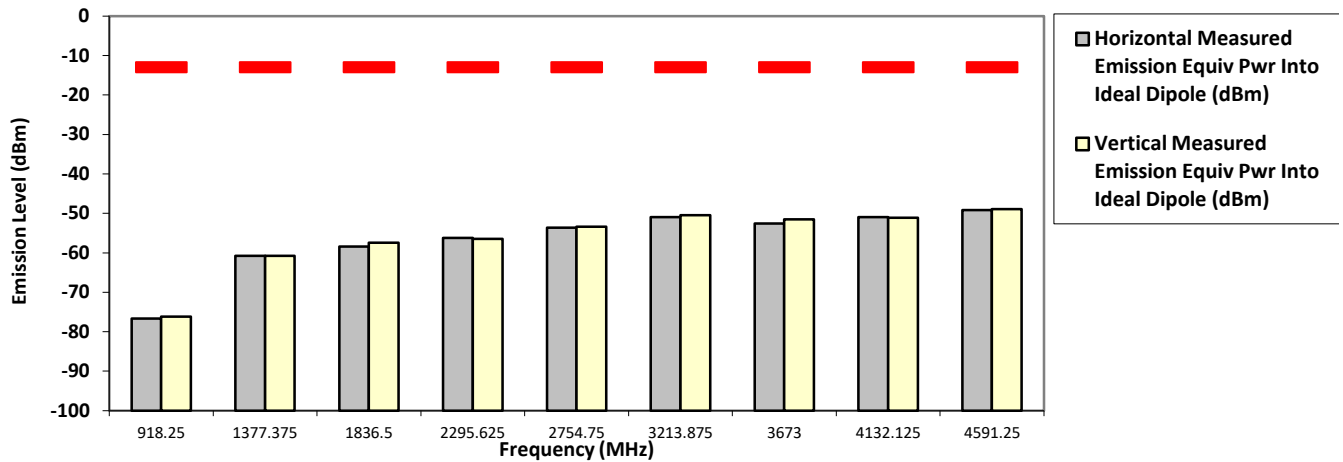

The data presented here was taken using the substitution method as found in the ANSI C63.26-2015 document.  
 Motorola Penang EMC Lab - Test Performed by: Nazrin & Rezza      Thu, 17 Aug, 2023

Remarks: \*\* Indicates the spurious emission could not be detected due to noise limitations or ambient.  
 \*Pursuant to CFR 47 Part 2.1057 ( c ), emissions attenuated more than 20 dB below the permissible limit are not reported  
 Temp(Deg): 23.4 Hum(%RH): 69.6

Remarks: Passed Results Marginal Results Failed Results

**SAC Transmitter Radiated Emission:**

**Model Number: H15XDF9PW6AN**      **S/N: 657TZP0033**      **SR:39809-EMC-00091**  
**Battery Part No: PMNN4813A**      **Test Mode: TX Analog**      **Accy Part No: NA**  
**467.775000 MHz**      **25 kHz**      **1.000 Watt(s) /Low Power**

Frequency (MHz)	Limit	Horizontal Measured Emission Equip Pwr Into Ideal Dipole (dBm)	Vertical Measured Emission Equip Pwr Into ideal Dipole (dBm)
935.5500	-13.0000	-75.2683 **	-75.9362 **
1403.3250	-13.0000	-59.7677 **	-61.1669 **
1871.1000	-13.0000	-58.4699 **	-58.1275 **
2338.8750	-13.0000	-56.1723 **	-56.1706 **
2806.6500	-13.0000	-53.8437 **	-53.9749 **
3274.4250	-13.0000	-51.7334 **	-51.5714 **
3742.2000	-13.0000	-51.8431 **	-51.5575 **
4209.9750	-13.0000	-50.2693 **	-49.4110 **
4677.7500	-13.0000	-48.3079 **	-49.6759 **

**RADIATED SPURIOUS EMISSIONS**

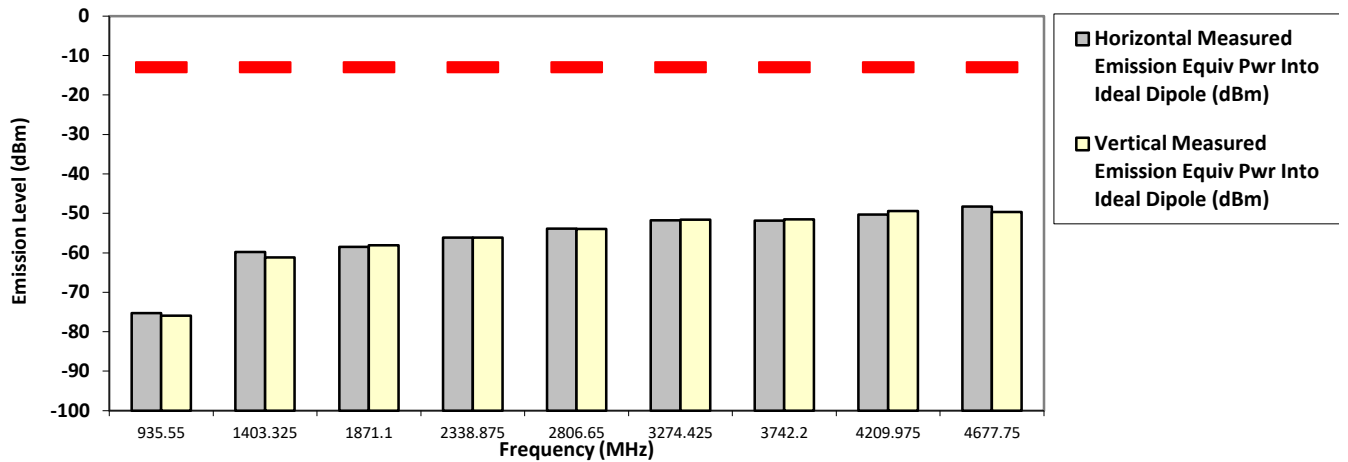

The data presented here was taken using the substitution method as found in the ANSI C63.26-2015 document.  
 Motorola Penang EMC Lab - Test Performed by: Nazrin & Rezza      Thu, 17 Aug, 2023

Remarks: \*\* Indicates the spurious emission could not be detected due to noise limitations or ambient.  
 \*Pursuant to CFR 47 Part 2.1057 ( c ), emissions attenuated more than 20 dB below the permissible limit are not reported  
 Temp(Deg): 23.4 Hum(%RH): 69.6

Remarks: Passed Results Marginal Results Failed Results

**SAC Transmitter Radiated Emission:**

**Model Number: H15XDF9PW6AN**      **S/N: 657TZP0033**      **SR:39809-EMC-00091**  
**Battery Part No: PMNN4813A**      **Test Mode: TX Analog**      **Accy Part No: NA**  
**467.775000 MHz**      **25 kHz**      **5.700 Watt(s) /Max Power**

Frequency (MHz)	Limit	Horizontal Measured Emission Equip Pwr Into Ideal Dipole (dBm)	Vertical Measured Emission Equip Pwr Into ideal Dipole (dBm)
935.5500	-13.0000	-75.7245 **	-75.0344 **
1403.3250	-13.0000	-61.4601 **	-60.3301 **
1871.1000	-13.0000	-57.7880 **	-57.3388 **
2338.8750	-13.0000	-56.0468 **	-56.2059 **
2806.6500	-13.0000	-54.2786 **	-54.2227 **
3274.4250	-13.0000	-52.2423 **	-51.9381 **
3742.2000	-13.0000	-50.7525 **	-50.6163 **
4209.9750	-13.0000	-50.9858 **	-50.9967 **
4677.7500	-13.0000	-49.2969 **	-49.7469 **

**RADIATED SPURIOUS EMISSIONS**

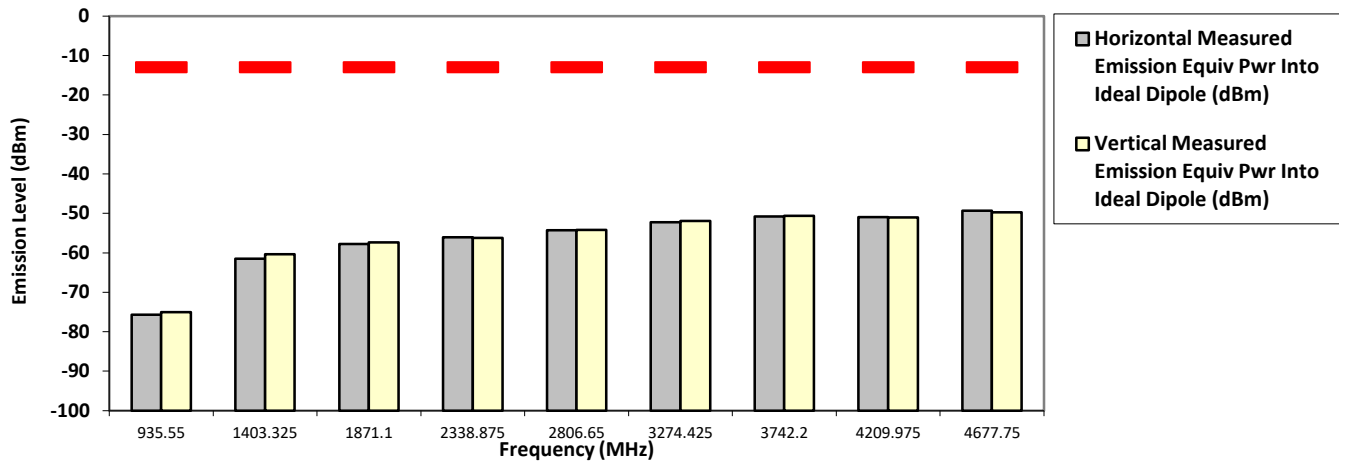

The data presented here was taken using the substitution method as found in the ANSI C63.26-2015 document.  
 Motorola Penang EMC Lab - Test Performed by: Nazrin & Rezza      Thu, 17 Aug, 2023

Remarks: \*\* Indicates the spurious emission could not be detected due to noise limitations or ambient.  
 \*Pursuant to CFR 47 Part 2.1057 ( c ), emissions attenuated more than 20 dB below the permissible limit are not reported  
 Temp(Deg): 23.4 Hum(%RH): 69.6

Remarks: Passed Results Marginal Results Failed Results

**SAC Transmitter Radiated Emission:**

**Model Number: H15XDF9PW6AN**      **S/N: 657TZP0033**      **SR:39809-EMC-00091**  
**Battery Part No: PMNN4813A**      **Test Mode: TX Analog**      **Accy Part No: NA**  
**482.012500 MHz**      **25 kHz**      **5.700 Watt(s) /Max Power**

Frequency (MHz)	Limit	Horizontal Measured Emission Equip Pwr Into Ideal Dipole (dBm)	Vertical Measured Emission Equip Pwr Into ideal Dipole (dBm)
964.0250	-13.0000	-75.4660 **	-73.7998 **
1446.0375	-13.0000	-59.8874 **	-60.2980 **
1928.0500	-13.0000	-57.5873 **	-57.4831 **
2410.0625	-13.0000	-55.1465 **	-53.9655 **
2892.0750	-13.0000	-53.9218 **	-53.9646 **
3374.0875	-13.0000	-51.8908 **	-51.6738 **
3856.1000	-13.0000	-50.9324 **	-51.2120 **
4338.1125	-13.0000	-49.9019 **	-49.2186 **
4820.1250	-13.0000	-48.2693 **	-48.6872 **

**RADIATED SPURIOUS EMISSIONS**

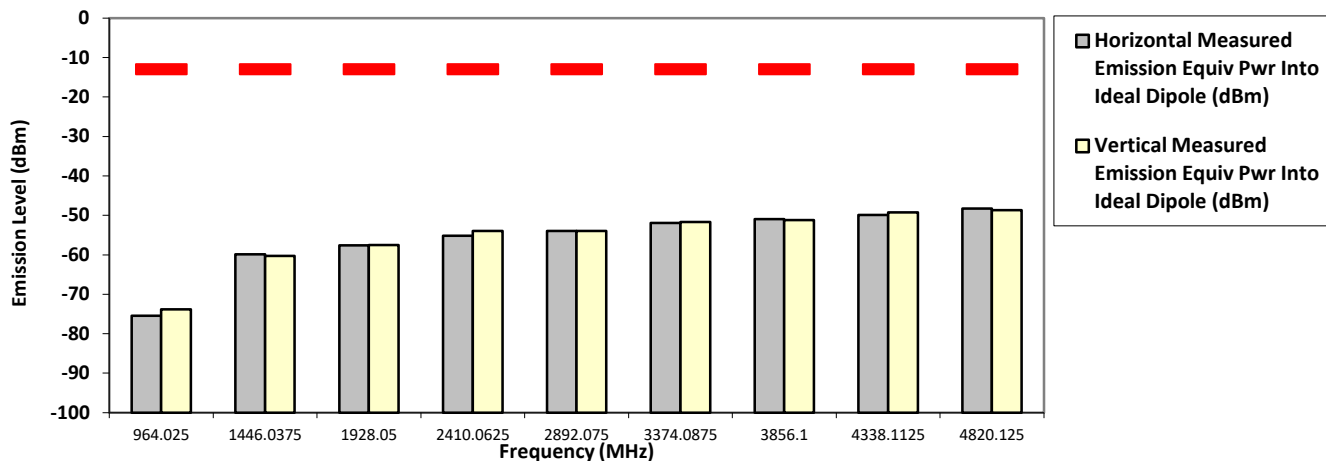

The data presented here was taken using the substitution method as found in the ANSI C63.26-2015 document.  
 Motorola Penang EMC Lab - Test Performed by: Nazrin & Rezza      Thu, 17 Aug, 2023

Remarks: \*\* Indicates the spurious emission could not be detected due to noise limitations or ambient.  
 \*Pursuant to CFR 47 Part 2.1057 ( c ), emissions attenuated more than 20 dB below the permissible limit are not reported  
 Temp(Deg): 23.4 Hum(%RH): 69.6

Remarks: Passed Results Marginal Results Failed Results

**SAC Transmitter Radiated Emission:**

**Model Number: H15XDF9PW6AN**      **S/N: 657TZP0033**      **SR:39809-EMC-00091**  
**Battery Part No: PMNN4813A**      **Test Mode: TX Analog**      **Accy Part No: NA**  
**511.987500 MHz**      **25 kHz**      **1.000 Watt(s) /Low Power**

Frequency (MHz)	Limit	Horizontal Measured Emission Equip Pwr Into Ideal Dipole (dBm)	Vertical Measured Emission Equip Pwr Into ideal Dipole (dBm)
1023.9750	-13.0000	-61.8480 **	-61.9025 **
1535.9625	-13.0000	-58.5348 **	-59.9090 **
2047.9500	-13.0000	-56.2176 **	-55.9859 **
2559.9375	-13.0000	-54.9478 **	-53.8985 **
3071.9250	-13.0000	-51.8701 **	-53.0013 **
3583.9125	-13.0000	-51.5273 **	-52.6257 **
4095.9000	-13.0000	-50.6407 **	-50.0735 **
4607.8875	-13.0000	-49.8336 **	-49.7041 **
5119.8750	-13.0000	-47.7637 **	-47.6913 **

**RADIATED SPURIOUS EMISSIONS**

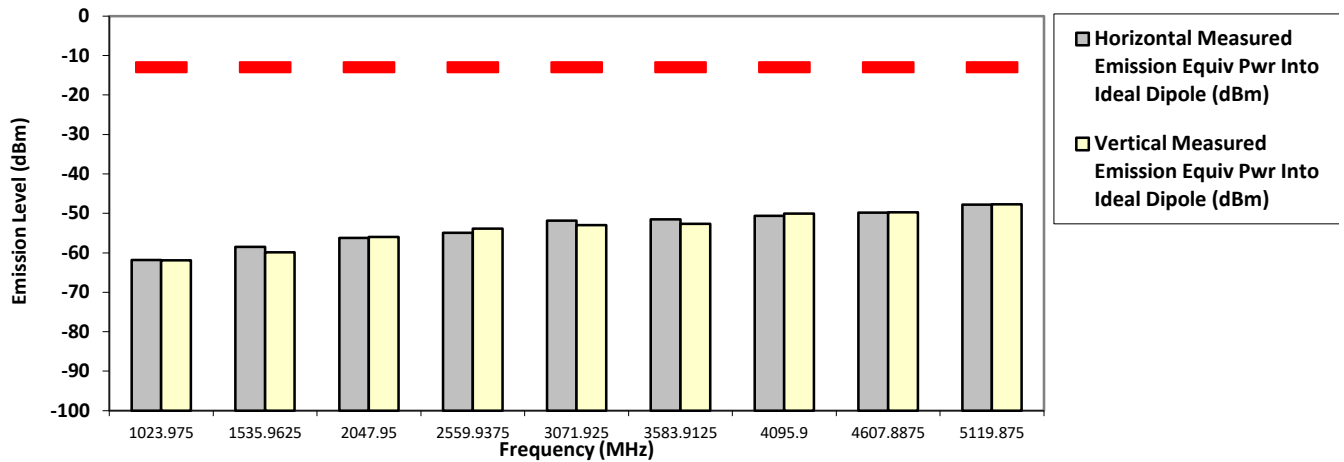

The data presented here was taken using the substitution method as found in the ANSI C63.26-2015 document.  
 Motorola Penang EMC Lab - Test Performed by: Nazrin & Rezza      Thu, 17 Aug, 2023

Remarks: \*\* Indicates the spurious emission could not be detected due to noise limitations or ambient.  
 \*Pursuant to CFR 47 Part 2.1057 ( c ), emissions attenuated more than 20 dB below the permissible limit are not reported  
 Temp(Deg): 23.4 Hum(%RH): 69.6

Remarks: Passed Results Marginal Results Failed Results

**SAC Transmitter Radiated Emission:**

**Model Number: H15XDF9PW6AN**      **S/N: 657TZP0033**      **SR:39809-EMC-00091**  
**Battery Part No: PMNN4813A**      **Test Mode: TX Analog**      **Accy Part No: NA**  
**511.987500 MHz**      **25 kHz**      **5.700 Watt(s) /Max Power**

Frequency (MHz)	Limit	Horizontal Measured Emission Equip Pwr Into Ideal Dipole (dBm)	Vertical Measured Emission Equip Pwr Into ideal Dipole (dBm)
1023.9750	-13.0000	-62.5628 **	-61.8775 **
1535.9625	-13.0000	-60.5991 **	-60.2533 **
2047.9500	-13.0000	-56.2056 **	-56.3422 **
2559.9375	-13.0000	-53.7159 **	-53.6778 **
3071.9250	-13.0000	-52.3720 **	-52.4844 **
3583.9125	-13.0000	-52.7423 **	-51.9334 **
4095.9000	-13.0000	-50.8552 **	-49.8349 **
4607.8875	-13.0000	-49.4707 **	-49.9248 **
5119.8750	-13.0000	-48.1286 **	-47.5803 **

**RADIATED SPURIOUS EMISSIONS**

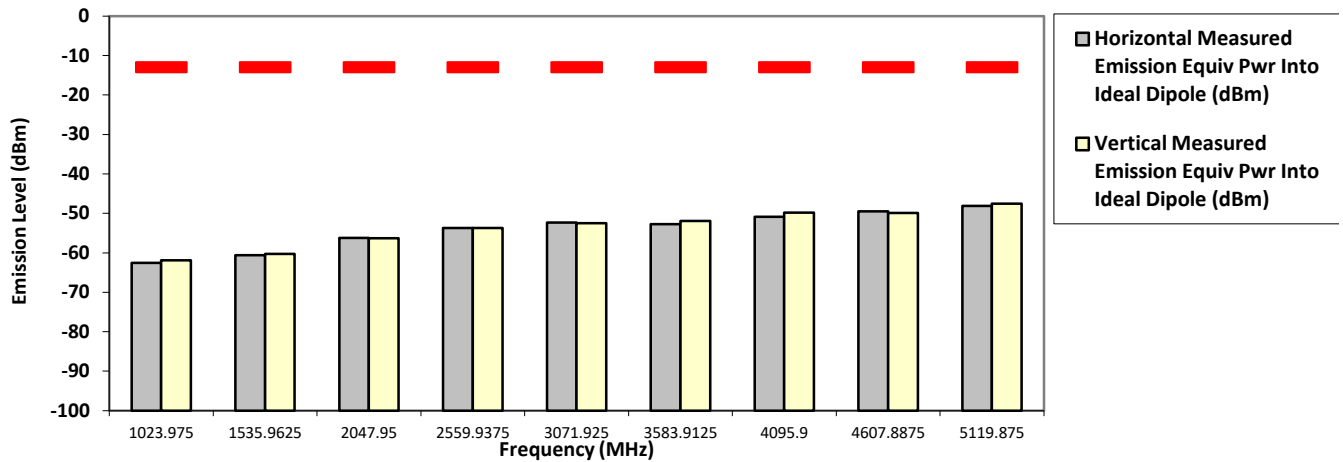

The data presented here was taken using the substitution method as found in the ANSI C63.26-2015 document.  
 Motorola Penang EMC Lab - Test Performed by: Nazrin & Rezza      Thu, 17 Aug, 2023

Remarks: \*\* Indicates the spurious emission could not be detected due to noise limitations or ambient.  
 \*Pursuant to CFR 47 Part 2.1057 ( c ), emissions attenuated more than 20 dB below the permissible limit are not reported  
 Temp(Deg): 23.4 Hum(%RH): 69.6

Remarks: Passed Results Marginal Results Failed Results

**SAC Transmitter Radiated Emission:**

**Model Number: H15XDF9PW6AN**      **S/N: 657TZP0033**      **SR:39809-EMC-00091**  
**Battery Part No: PMNN4813A**      **Test Mode: TX Analog**      **Accy Part No: NA**  
**519.987500 MHz**      **25 kHz**      **5.700 Watt(s) /Max Power**

Frequency (MHz)	Limit	Horizontal Measured Emission Equip Pwr Into Ideal Dipole (dBm)	Vertical Measured Emission Equip Pwr Into ideal Dipole (dBm)
1039.9750	-13.0000	-61.3024 **	-62.6867 **
1559.9625	-13.0000	-59.7279 **	-59.2208 **
2079.9500	-13.0000	-54.9813 **	-55.7973 **
2599.9375	-13.0000	-53.5911 **	-53.8143 **
3119.9250	-13.0000	-52.1811 **	-52.8439 **
3639.9125	-13.0000	-53.0818 **	-52.5857 **
4159.9000	-13.0000	-50.0366 **	-50.6464 **
4679.8875	-13.0000	-49.3307 **	-48.4148 **
5199.8750	-13.0000	-47.3446 **	-47.5958 **

**RADIATED SPURIOUS EMISSIONS**

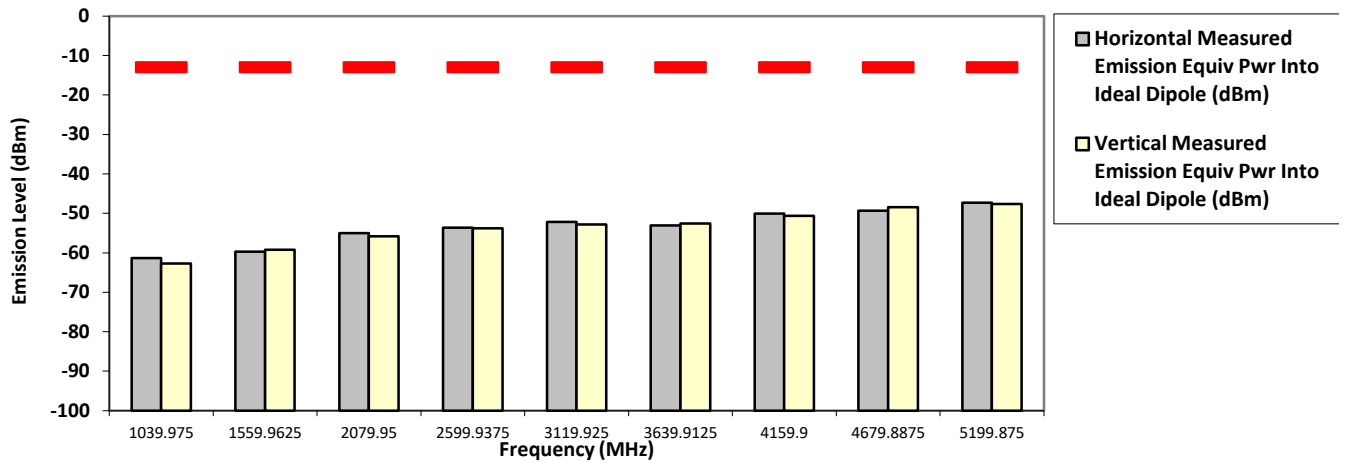

The data presented here was taken using the substitution method as found in the ANSI C63.26-2015 document.  
 Motorola Penang EMC Lab - Test Performed by: Nazrin & Rezza      Thu, 17 Aug, 2023

Remarks: \*\* Indicates the spurious emission could not be detected due to noise limitations or ambient.  
 \*Pursuant to CFR 47 Part 2.1057 ( c ), emissions attenuated more than 20 dB below the permissible limit are not reported  
 Temp(Deg): 23.4 Hum(%RH): 69.6

Remarks: Passed Results Marginal Results Failed Results

### 6.10.3. Test Result (Digital)

**SAC Transmitter Radiated Emission:**

Model Number: H25XDF9PW6AN      S/N: 287TZP0060      SR:39809-EMC-00045  
 Battery Part No: PMNN4813A      Accy Part No: NA  
 Test Mode: TX APCO Digital C4FM  
 380.012500 MHz      12.5 kHz      5.700 Watt(s) /Max Power

Frequency (MHz)	Limit	Horizontal Measured Emission Equiv Pwr Into Ideal Dipole (dBm)	Vertical Measured Emission Equiv Pwr Into ideal Dipole (dBm)
760.0250	-20.0000	-75.0926 **	-76.6343 **
1140.0375	-20.0000	-61.6499 **	-61.7964 **
1520.0500	-20.0000	-59.9916 **	-59.2626 **
1900.0625	-20.0000	-59.2633 **	-58.8015 **
2280.0750	-20.0000	-57.3493 **	-56.7056 **
2660.0875	-20.0000	-54.7585 **	-54.2243 **
3040.1000	-20.0000	-53.9408 **	-53.5237 **
3420.1125	-20.0000	-52.5619 **	-52.7418 **
3800.1250	-20.0000	-51.3634 **	-51.7888 **

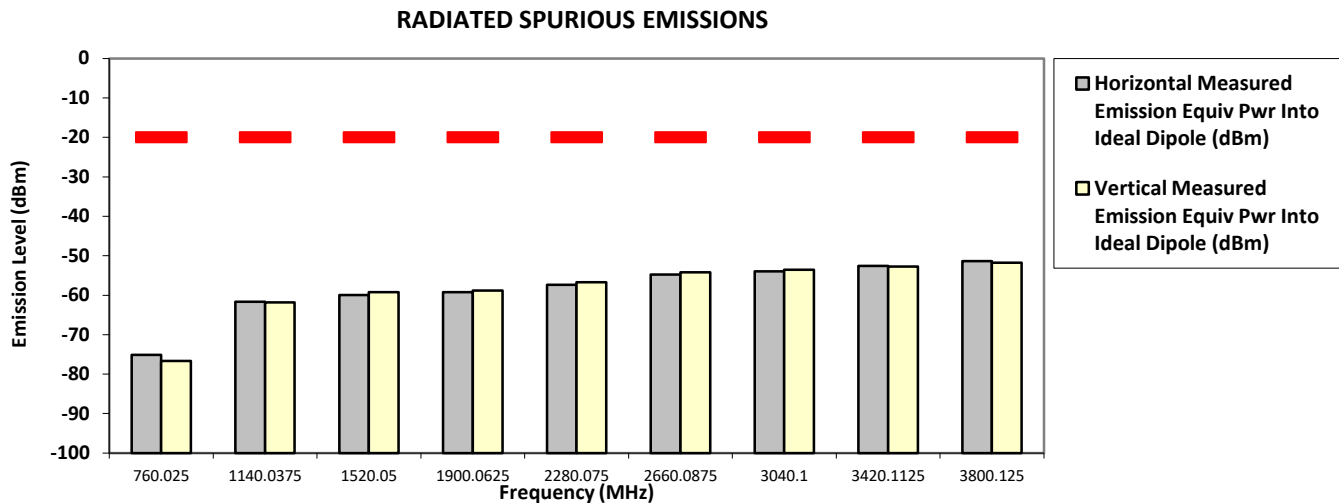

The data presented here was taken using the substitution method as found in the ANSI C63.26-2015 document.  
 Motorola Penang EMC Lab - Test Performed by: Nazrin & Rezza      Fri, 11 Aug, 2023

Remarks: \*\* Indicates the spurious emission could not be detected due to noise limitations or ambient.  
 \*Pursuant to CFR 47 Part 2.1057 ( c ), emissions attenuated more than 20 dB below the permissible limit are not reported  
 Temp(Deg): 23.4 Hum(%RH): 69.6

Remarks: Passed Results Marginal Results Failed Results



**SAC Transmitter Radiated Emission:**

**Model Number: H25XDF9PW6AN**      **S/N: 287TZP0060**      **SR:39809-EMC-00045**  
**Battery Part No: PMNN4813A**      **Accy Part No: NA**  
**Test Mode: TX APCO Digital C4FM**  
**406.200000 MHz**      **12.5 kHz**      **5.700 Watt(s) /Max Power**

Frequency (MHz)	Limit	Horizontal Measured Emission Equiv Pwr Into Ideal Dipole (dBm)	Vertical Measured Emission Equiv Pwr Into ideal Dipole (dBm)
812.4000	-20.0000	-76.1647 **	-75.7214 **
1218.6000	-20.0000	-61.1260 **	-61.8391 **
1624.8000	-20.0000	-59.3239 **	-58.5050 **
2031.0000	-20.0000	-55.7835 **	-55.1424 **
2437.2000	-20.0000	-54.4507 **	-55.5997 **
2843.4000	-20.0000	-55.1722 **	-55.4189 **
3249.6000	-20.0000	-52.3826 **	-51.5087 **
3655.8000	-20.0000	-51.3515 **	-53.2397 **
4062.0000	-20.0000	-50.7305 **	-50.5591 **

**RADIATED SPURIOUS EMISSIONS**

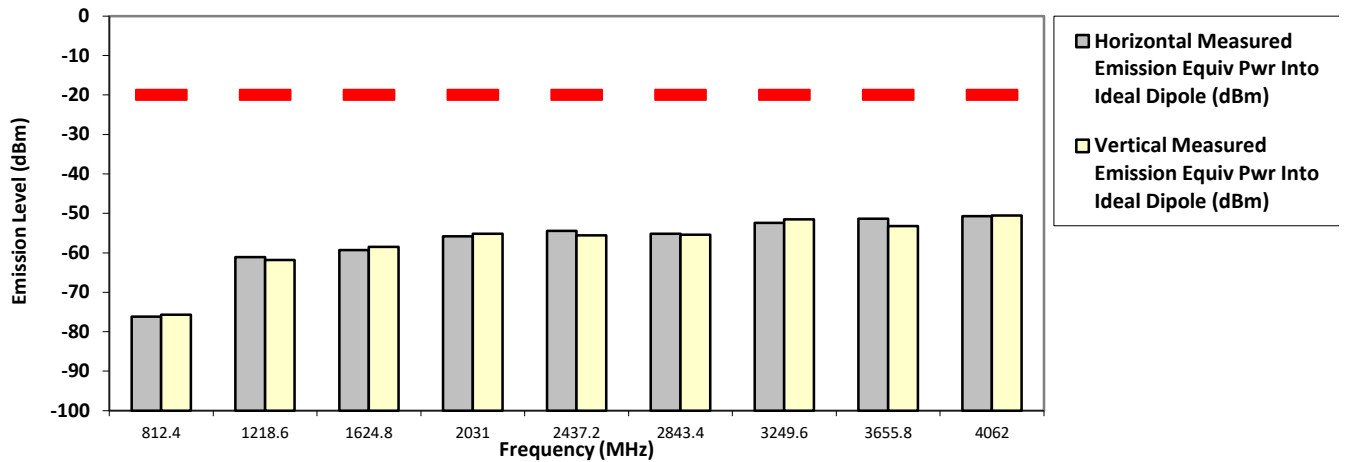

The data presented here was taken using the substitution method as found in the ANSI C63.26-2015 document.  
 Motorola Penang EMC Lab - Test Performed by: Nazrin & Rezza      Fri, 11 Aug, 2023

Remarks: \*\* Indicates the spurious emission could not be detected due to noise limitations or ambient.  
 \*Pursuant to CFR 47 Part 2.1057 ( c ), emissions attenuated more than 20 dB below the permissible limit are not reported  
 Temp(Deg): 23.4 Hum(%RH): 69.6

Remarks: Passed Results Marginal Results Failed Results

**SAC Transmitter Radiated Emission:**

**Model Number: H25XDF9PW6AN**      **S/N: 287TZP0060**      **SR:39809-EMC-00045**  
**Battery Part No: PMNN4813A**      **Accy Part No: NA**  
**Test Mode: TX APCO Digital C4FM**  
**450.025000 MHz**      **12.5 kHz**      **1.000 Watt(s) /Low Power**

Frequency (MHz)	Limit	Horizontal Measured Emission Equip Pwr Into Ideal Dipole (dBm)	Vertical Measured Emission Equip Pwr Into ideal Dipole (dBm)
900.0500	-20.0000	-75.2389 **	-76.3769 **
1350.0750	-20.0000	-61.1585 **	-59.8971 **
1800.1000	-20.0000	-59.2292 **	-58.7901 **
2250.1250	-20.0000	-55.2154 **	-56.2949 **
2700.1500	-20.0000	-54.8675 **	-55.7256 **
3150.1750	-20.0000	-52.4177 **	-53.0075 **
3600.2000	-20.0000	-52.9214 **	-52.1981 **
4050.2250	-20.0000	-50.2617 **	-51.6791 **
4500.2500	-20.0000	-50.0339 **	-50.6941 **

**RADIATED SPURIOUS EMISSIONS**

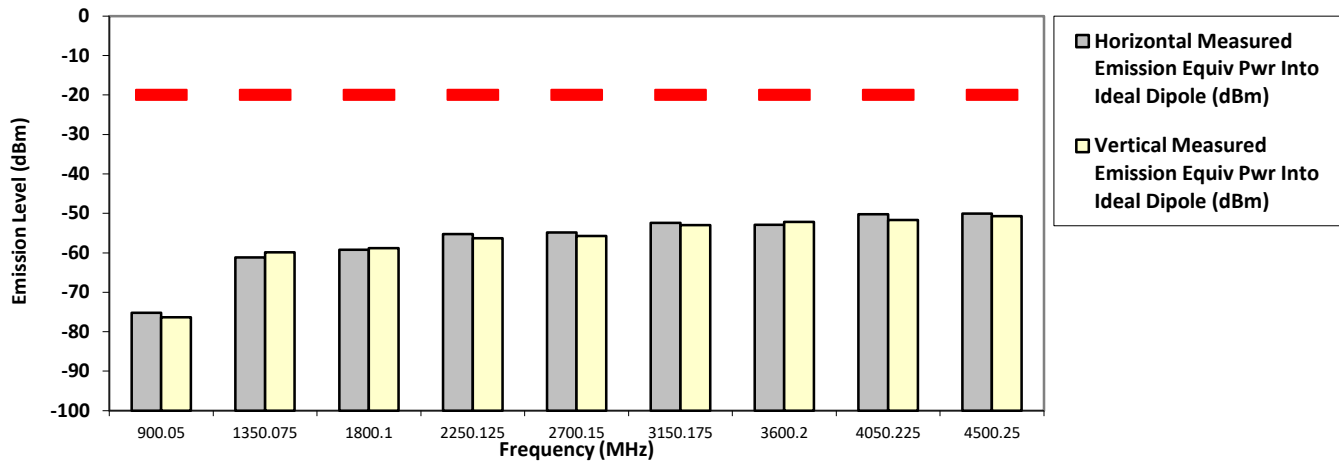

The data presented here was taken using the substitution method as found in the ANSI C63.26-2015 document.  
 Motorola Penang EMC Lab - Test Performed by: Nazrin & Rezza      Fri, 11 Aug, 2023

Remarks: \*\* Indicates the spurious emission could not be detected due to noise limitations or ambient.  
 \*Pursuant to CFR 47 Part 2.1057 ( c ), emissions attenuated more than 20 dB below the permissible limit are not reported  
 Temp(Deg): 23.4 Hum(%RH): 69.6

Remarks: Passed Results Marginal Results Failed Results

**SAC Transmitter Radiated Emission:**

**Model Number: H25XDF9PW6AN**      **S/N: 287TZP0060**      **SR:39809-EMC-00045**  
**Battery Part No: PMNN4813A**      **Accy Part No: NA**  
**Test Mode: TX APCO Digital C4FM**  
**450.025000 MHz**      **12.5 kHz**      **5.700 Watt(s) /Max Power**

Frequency (MHz)	Limit	Horizontal Measured Emission Equip Pwr Into Ideal Dipole (dBm)	Vertical Measured Emission Equip Pwr Into ideal Dipole (dBm)
900.0500	-20.0000	-76.4772 **	-75.4956 **
1350.0750	-20.0000	-61.4941 **	-60.4399 **
1800.1000	-20.0000	-58.8873 **	-58.8992 **
2250.1250	-20.0000	-57.1184 **	-56.7846 **
2700.1500	-20.0000	-54.7050 **	-54.9531 **
3150.1750	-20.0000	-52.9979 **	-52.8618 **
3600.2000	-20.0000	-53.3328 **	-53.2534 **
4050.2250	-20.0000	-50.8810 **	-50.9113 **
4500.2500	-20.0000	-50.1569 **	-49.6437 **

**RADIATED SPURIOUS EMISSIONS**

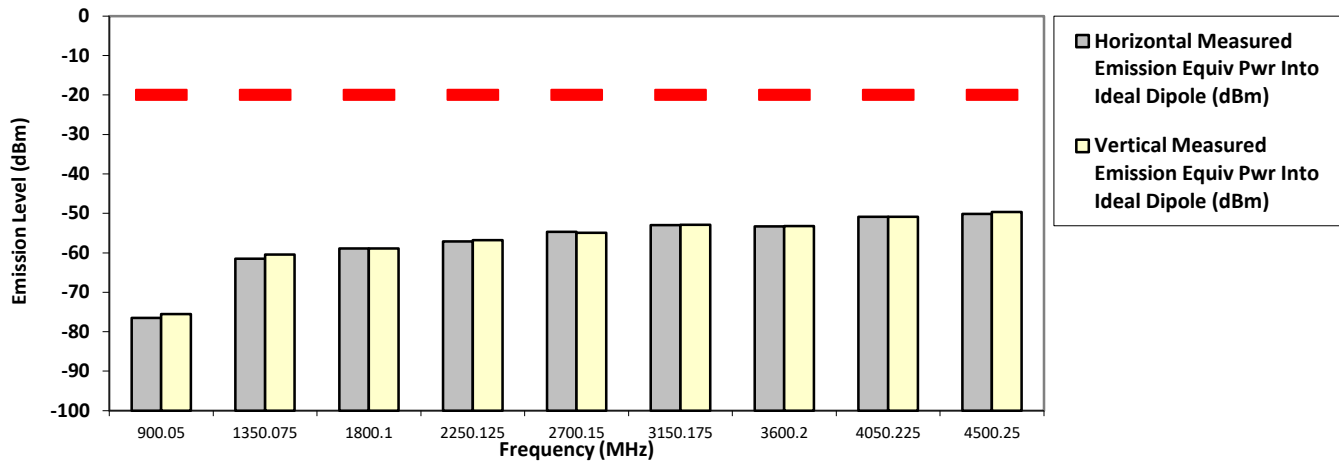

The data presented here was taken using the substitution method as found in the ANSI C63.26-2015 document.  
 Motorola Penang EMC Lab - Test Performed by: Nazrin & Rezza      Fri, 11 Aug, 2023

Remarks: \*\* Indicates the spurious emission could not be detected due to noise limitations or ambient.  
 \*Pursuant to CFR 47 Part 2.1057 ( c ), emissions attenuated more than 20 dB below the permissible limit are not reported  
 Temp(Deg): 23.4 Hum(%RH): 69.6

Remarks: Passed Results Marginal Results Failed Results

**SAC Transmitter Radiated Emission:**

**Model Number: H25XDF9PW6AN**      **S/N: 287TZP0060**      **SR:39809-EMC-00045**  
**Battery Part No: PMNN4813A**      **Accy Part No: NA**  
**Test Mode: TX APCO Digital C4FM**  
**459.125000 MHz**      **12.5 kHz**      **5.700 Watt(s) /Max Power**

Frequency (MHz)	Limit	Horizontal Measured Emission Equip Pwr Into Ideal Dipole (dBm)	Vertical Measured Emission Equip Pwr Into ideal Dipole (dBm)
918.2500	-20.0000	-76.0045 **	-76.6527 **
1377.3750	-20.0000	-60.9436 **	-60.2853 **
1836.5000	-20.0000	-58.8993 **	-57.4063 **
2295.6250	-20.0000	-56.7657 **	-56.7324 **
2754.7500	-20.0000	-54.7425 **	-54.5900 **
3213.8750	-20.0000	-53.0270 **	-52.8163 **
3673.0000	-20.0000	-52.7075 **	-53.4361 **
4132.1250	-20.0000	-50.3814 **	-51.4369 **
4591.2500	-20.0000	-50.8090 **	-50.1668 **

**RADIATED SPURIOUS EMISSIONS**

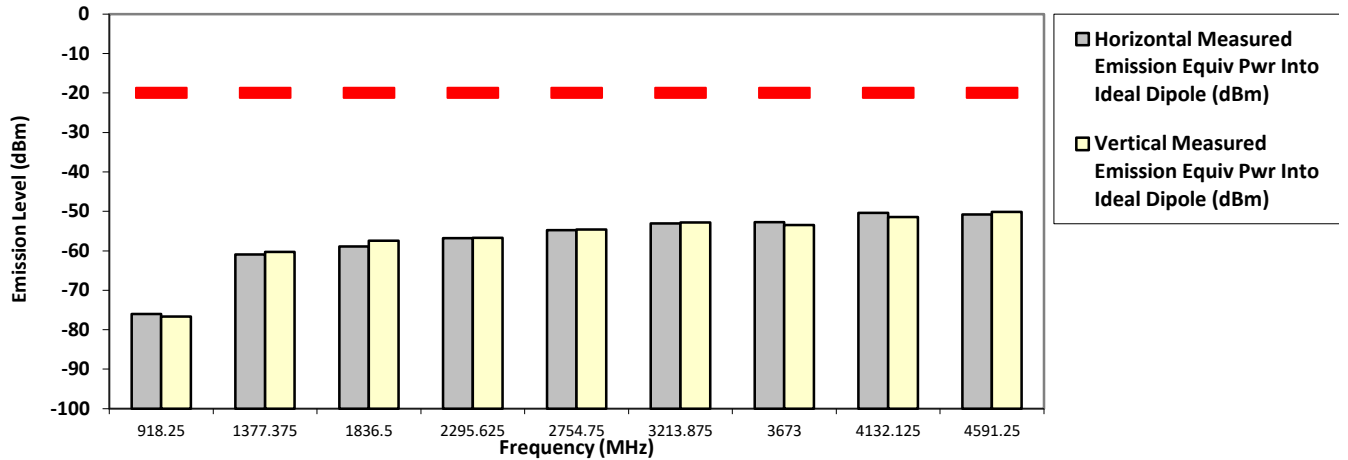

The data presented here was taken using the substitution method as found in the ANSI C63.26-2015 document.  
 Motorola Penang EMC Lab - Test Performed by: Nazrin & Rezza      Fri, 11 Aug, 2023

Remarks: \*\* Indicates the spurious emission could not be detected due to noise limitations or ambient.  
 \*Pursuant to CFR 47 Part 2.1057 ( c ), emissions attenuated more than 20 dB below the permissible limit are not reported  
 Temp(Deg): 23.4 Hum(%RH): 69.6

Remarks: Passed Results Marginal Results Failed Results

**SAC Transmitter Radiated Emission:**

**Model Number: H25XDF9PW6AN**      **S/N: 287TZP0060**      **SR:39809-EMC-00045**  
**Battery Part No: PMNN4813A**      **Accy Part No: NA**  
**Test Mode: TX APCO Digital C4FM**  
**467.775000 MHz**      **12.5 kHz**      **5.700 Watt(s) /Max Power**

Frequency (MHz)	Limit	Horizontal Measured Emission Equiv Pwr Into Ideal Dipole (dBm)	Vertical Measured Emission Equiv Pwr Into ideal Dipole (dBm)
935.5500	-20.0000	-75.7144 **	-75.7619 **
1403.3250	-20.0000	-61.4225 **	-60.4655 **
1871.1000	-20.0000	-59.1347 **	-58.7499 **
2338.8750	-20.0000	-57.1191 **	-56.5932 **
2806.6500	-20.0000	-53.4203 **	-53.6967 **
3274.4250	-20.0000	-52.7476 **	-52.1018 **
3742.2000	-20.0000	-51.5744 **	-52.8931 **
4209.9750	-20.0000	-51.6266 **	-51.1714 **
4677.7500	-20.0000	-50.1911 **	-48.5513 **

**RADIATED SPURIOUS EMISSIONS**

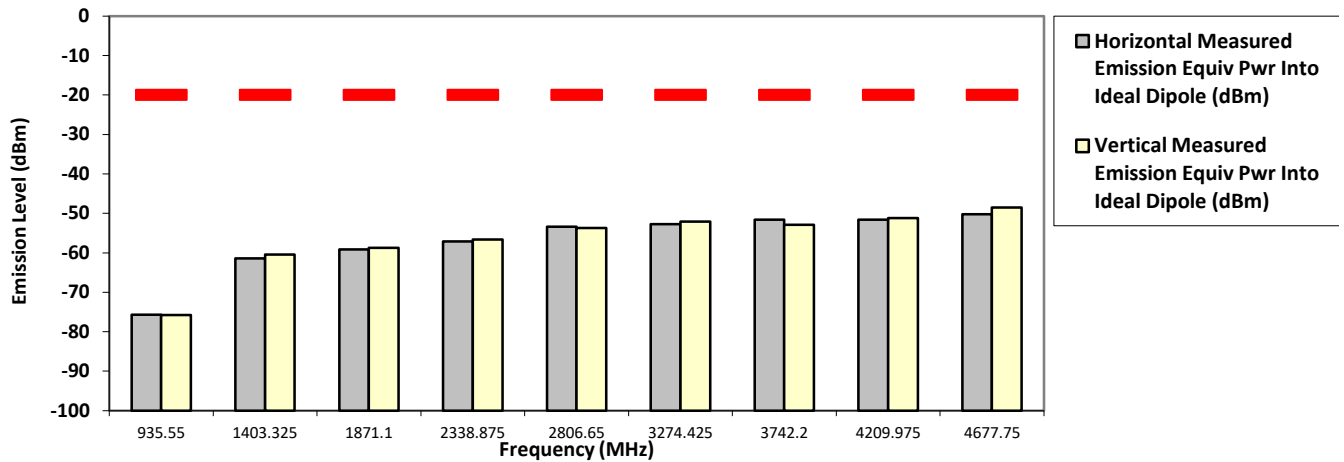

The data presented here was taken using the substitution method as found in the ANSI C63.26-2015 document.  
 Motorola Penang EMC Lab - Test Performed by: Nazrin & Rezza      Fri, 11 Aug, 2023

Remarks: \*\* Indicates the spurious emission could not be detected due to noise limitations or ambient.  
 \*Pursuant to CFR 47 Part 2.1057 ( c ), emissions attenuated more than 20 dB below the permissible limit are not reported  
 Temp(Deg): 23.4 Hum(%RH): 69.6

Remarks: Passed Results Marginal Results Failed Results

**SAC Transmitter Radiated Emission:**

**Model Number: H25XDF9PW6AN**      **S/N: 287TZP0060**      **SR:39809-EMC-00045**  
**Battery Part No: PMNN4813A**      **Accy Part No: NA**  
**Test Mode: TX APCO Digital C4FM**  
**482.012500 MHz**      **12.5 kHz**      **5.700 Watt(s) /Max Power**

Frequency (MHz)	Limit	Horizontal Measured Emission Equip Pwr Into Ideal Dipole (dBm)	Vertical Measured Emission Equip Pwr Into ideal Dipole (dBm)
964.0250	-20.0000	-75.3233 **	-73.6217 **
1446.0375	-20.0000	-62.0643 **	-61.0018 **
1928.0500	-20.0000	-56.4222 **	-56.8388 **
2410.0625	-20.0000	-54.9211 **	-55.0734 **
2892.0750	-20.0000	-55.2093 **	-54.5954 **
3374.0875	-20.0000	-52.3521 **	-51.6824 **
3856.1000	-20.0000	-50.8708 **	-49.9827 **
4338.1125	-20.0000	-49.7600 **	-49.8740 **
4820.1250	-20.0000	-48.7222 **	-47.7947 **

**RADIATED SPURIOUS EMISSIONS**

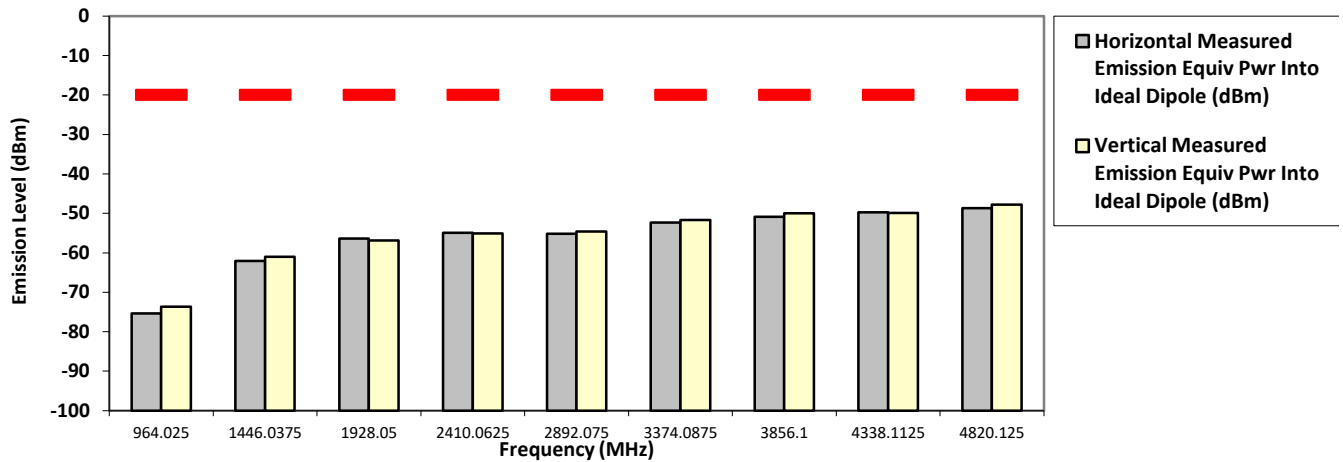

The data presented here was taken using the substitution method as found in the ANSI C63.26-2015 document.  
 Motorola Penang EMC Lab - Test Performed by: Nazrin & Rezza      Fri, 11 Aug, 2023

Remarks: \*\* Indicates the spurious emission could not be detected due to noise limitations or ambient.  
 \*Pursuant to CFR 47 Part 2.1057 ( c ), emissions attenuated more than 20 dB below the permissible limit are not reported  
 Temp(Deg): 23.4 Hum(%RH): 69.6

Remarks: Passed Results Marginal Results Failed Results

**SAC Transmitter Radiated Emission:**

**Model Number: H25XDF9PW6AN**      **S/N: 287TZP0060**      **SR:39809-EMC-00045**  
**Battery Part No: PMNN4813A**      **Accy Part No: NA**  
**Test Mode: TX APCO Digital C4FM**  
**511.987500 MHz**      **12.5 kHz**      **1.000 Watt(s) /Low Power**

Frequency (MHz)	Limit	Horizontal Measured Emission Equiv Pwr Into Ideal Dipole (dBm)	Vertical Measured Emission Equiv Pwr Into ideal Dipole (dBm)
1023.9750	-20.0000	-62.8751 **	-62.6865 **
1535.9625	-20.0000	-60.6036 **	-58.3091 **
2047.9500	-20.0000	-56.9981 **	-54.9586 **
2559.9375	-20.0000	-54.4542 **	-55.0833 **
3071.9250	-20.0000	-52.4931 **	-52.7246 **
3583.9125	-20.0000	-53.0858 **	-51.3875 **
4095.9000	-20.0000	-50.8177 **	-50.1952 **
4607.8875	-20.0000	-49.5178 **	-49.5704 **
5119.8750	-20.0000	-48.8167 **	-48.3307 **

**RADIATED SPURIOUS EMISSIONS**

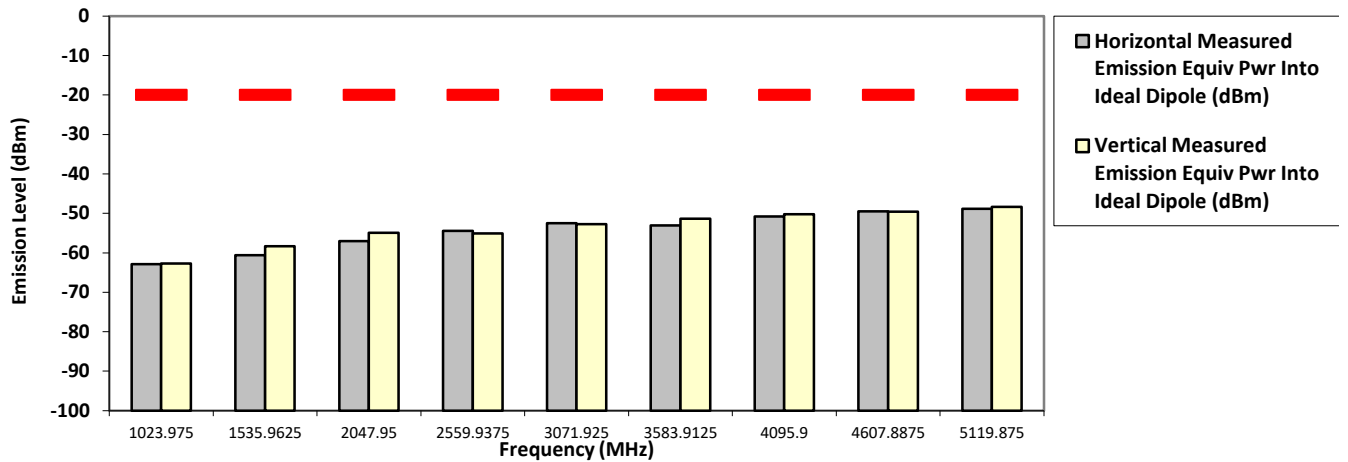

The data presented here was taken using the substitution method as found in the ANSI C63.26-2015 document.  
 Motorola Penang EMC Lab - Test Performed by: Nazrin & Rezza      Fri, 11 Aug, 2023

Remarks: \*\* Indicates the spurious emission could not be detected due to noise limitations or ambient.  
 \*Pursuant to CFR 47 Part 2.1057 ( c ), emissions attenuated more than 20 dB below the permissible limit are not reported  
 Temp(Deg): 23.4 Hum(%RH): 69.6

Remarks: Passed Results Marginal Results Failed Results

**SAC Transmitter Radiated Emission:**

**Model Number: H25XDF9PW6AN**      **S/N: 287TZP0060**      **SR:39809-EMC-00045**  
**Battery Part No: PMNN4813A**      **Accy Part No: NA**  
**Test Mode: TX APCO Digital C4FM**  
**511.987500 MHz**      **12.5 kHz**      **5.700 Watt(s) /Max Power**

Frequency (MHz)	Limit	Horizontal Measured Emission Equiv Pwr Into Ideal Dipole (dBm)	Vertical Measured Emission Equiv Pwr Into ideal Dipole (dBm)
1023.9750	-20.0000	-63.0404 **	-62.1328 **
1535.9625	-20.0000	-60.7951 **	-59.5017 **
2047.9500	-20.0000	-54.7266 **	-56.8901 **
2559.9375	-20.0000	-54.8650 **	-54.7599 **
3071.9250	-20.0000	-51.0417 **	-52.0101 **
3583.9125	-20.0000	-52.1951 **	-53.1685 **
4095.9000	-20.0000	-50.3966 **	-51.5328 **
4607.8875	-20.0000	-49.5203 **	-49.9167 **
5119.8750	-20.0000	-47.5294 **	-48.5660 **

**RADIATED SPURIOUS EMISSIONS**

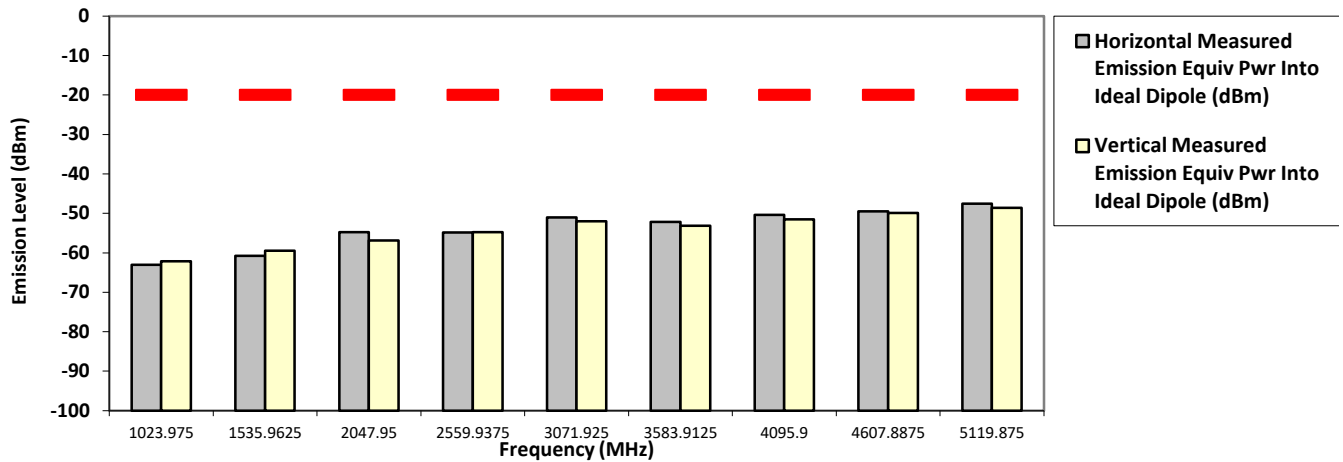

The data presented here was taken using the substitution method as found in the ANSI C63.26-2015 document.  
 Motorola Penang EMC Lab - Test Performed by: Nazrin & Rezza      Fri, 11 Aug, 2023

Remarks: \*\* Indicates the spurious emission could not be detected due to noise limitations or ambient.  
 \*Pursuant to CFR 47 Part 2.1057 ( c ), emissions attenuated more than 20 dB below the permissible limit are not reported  
 Temp(Deg): 23.4 Hum(%RH): 69.6

Remarks: Passed Results Marginal Results Failed Results



**SAC Transmitter Radiated Emission:**

**Model Number: H25XDF9PW6AN**      **S/N: 287TZP0060**      **SR:39809-EMC-00045**  
**Battery Part No: PMNN4813A**      **Accy Part No: NA**  
**Test Mode: TX APCO Digital C4FM**  
**519.987500 MHz**      **12.5 kHz**      **5.700 Watt(s) /Max Power**

Frequency (MHz)	Limit	Horizontal Measured Emission Equip Pwr Into Ideal Dipole (dBm)	Vertical Measured Emission Equip Pwr Into ideal Dipole (dBm)
1039.9750	-20.0000	-62.6317 **	-62.5055 **
1559.9625	-20.0000	-59.2026 **	-58.8385 **
2079.9500	-20.0000	-55.1245 **	-56.7072 **
2599.9375	-20.0000	-54.6049 **	-54.3672 **
3119.9250	-20.0000	-52.9753 **	-51.4795 **
3639.9125	-20.0000	-53.8008 **	-52.6940 **
4159.9000	-20.0000	-50.3602 **	-51.1492 **
4679.8875	-20.0000	-49.8837 **	-49.0584 **
5199.8750	-20.0000	-46.4909 **	-47.3653 **

**RADIATED SPURIOUS EMISSIONS**

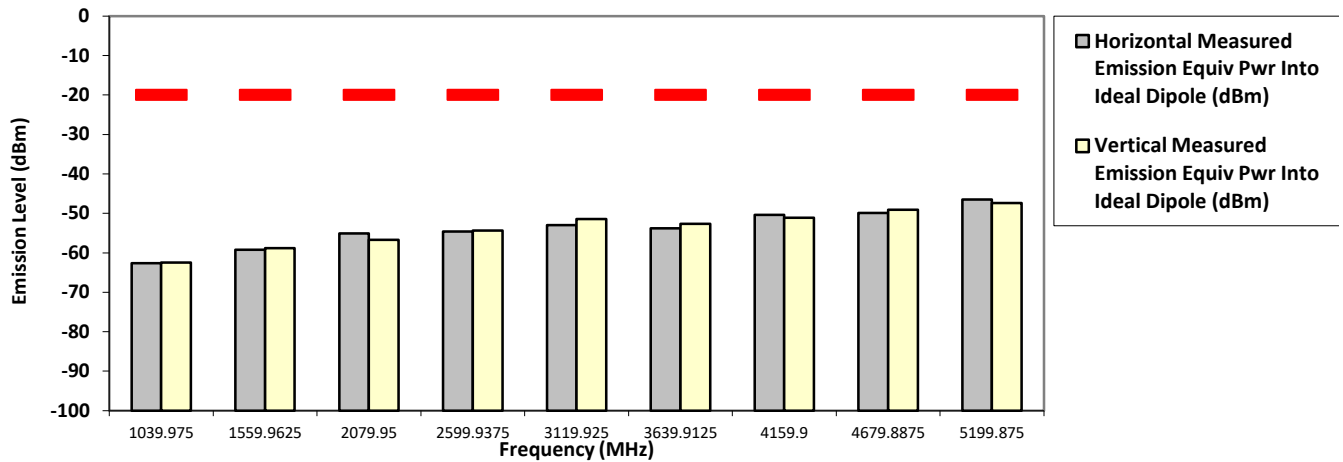

The data presented here was taken using the substitution method as found in the ANSI C63.26-2015 document.  
 Motorola Penang EMC Lab - Test Performed by: Nazrin & Rezza      Fri, 11 Aug, 2023

Remarks: \*\* Indicates the spurious emission could not be detected due to noise limitations or ambient.  
 \*Pursuant to CFR 47 Part 2.1057 ( c ), emissions attenuated more than 20 dB below the permissible limit are not reported  
 Temp(Deg): 23.4 Hum(%RH): 69.6

Remarks: Passed Results Marginal Results Failed Results

**SAC Transmitter Radiated Emission:**

**Model Number: H25XDF9PW6AN**      **S/N: 287TZP0060**      **SR:39809-EMC-00045**  
**Battery Part No: PMNN4813A**      **Accy Part No: NA**  
**Test Mode: TX APCO Digital Phase II**  
**380.012500 MHz**      **12.5 kHz**      **5.700 Watt(s) /Max Power**

Frequency (MHz)	Limit	Horizontal Measured Emission Equip Pwr Into Ideal Dipole (dBm)	Vertical Measured Emission Equip Pwr Into ideal Dipole (dBm)
760.0250	-20.0000	-76.4622 **	-76.7207 **
1140.0375	-20.0000	-61.6598 **	-62.4190 **
1520.0500	-20.0000	-61.1614 **	-60.5391 **
1900.0625	-20.0000	-58.6302 **	-58.1208 **
2280.0750	-20.0000	-57.0739 **	-56.4719 **
2660.0875	-20.0000	-54.1852 **	-53.8184 **
3040.1000	-20.0000	-53.3804 **	-52.6050 **
3420.1125	-20.0000	-52.1830 **	-51.8165 **
3800.1250	-20.0000	-51.6855 **	-49.8205 **

**RADIATED SPURIOUS EMISSIONS**

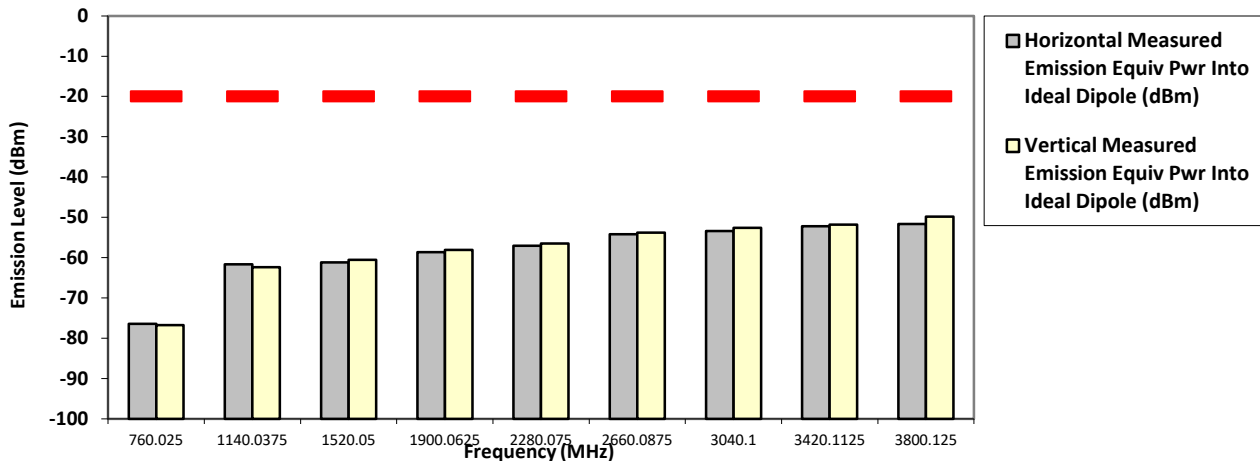

The data presented here was taken using the substitution method as found in the ANSI C63.26-2015 document.  
 Motorola Penang EMC Lab - Test Performed by: Nazrin & Rezza      Fri, 11 Aug, 2023

Remarks: \*\* Indicates the spurious emission could not be detected due to noise limitations or ambient.  
 \*Pursuant to CFR 47 Part 2.1057 ( c ), emissions attenuated more than 20 dB below the permissible limit are not reported  
 Temp(Deg): 23.4 Hum(%RH): 69.6

Remarks: Passed Results Marginal Results Failed Results

**SAC Transmitter Radiated Emission:**

**Model Number: H25XDF9PW6AN**      **S/N: 287TZP0060**      **SR:39809-EMC-00045**  
**Battery Part No: PMNN4813A**      **Accy Part No: NA**  
**Test Mode: TX APCO Digital Phase II**  
**406.200000 MHz**      **12.5 kHz**      **5.700 Watt(s) /Max Power**

Frequency (MHz)	Limit	Horizontal Measured Emission Equip Pwr Into Ideal Dipole (dBm)	Vertical Measured Emission Equip Pwr Into ideal Dipole (dBm)
812.4000	-20.0000	-75.5779 **	-76.7992 **
1218.6000	-20.0000	-61.5109 **	-60.6883 **
1624.8000	-20.0000	-58.8358 **	-59.3886 **
2031.0000	-20.0000	-56.1322 **	-56.7551 **
2437.2000	-20.0000	-55.4380 **	-55.8692 **
2843.4000	-20.0000	-52.9029 **	-54.4614 **
3249.6000	-20.0000	-51.1344 **	-49.3443 **
3655.8000	-20.0000	-53.5670 **	-53.2042 **
4062.0000	-20.0000	-49.7672 **	-49.9878 **

**RADIATED SPURIOUS EMISSIONS**

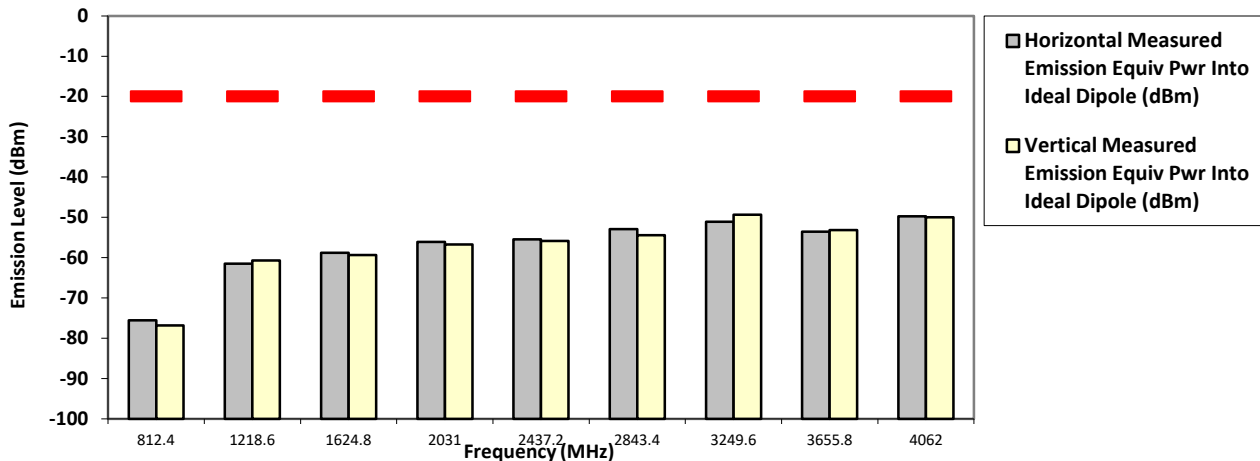

The data presented here was taken using the substitution method as found in the ANSI C63.26-2015 document.  
 Motorola Penang EMC Lab - Test Performed by: Nazrin & Rezza      Fri, 11 Aug, 2023

Remarks: \*\* Indicates the spurious emission could not be detected due to noise limitations or ambient.  
 \*Pursuant to CFR 47 Part 2.1057 ( c ), emissions attenuated more than 20 dB below the permissible limit are not reported  
 Temp(Deg): 23.4 Hum(%RH): 69.6

Remarks: Passed Results Marginal Results Failed Results

**SAC Transmitter Radiated Emission:**

**Model Number: H25XDF9PW6AN**      **S/N: 287TZP0060**      **SR:39809-EMC-00045**  
**Battery Part No: PMNN4813A**      **Accy Part No: NA**  
**Test Mode: TX APCO Digital Phase II**  
**450.025000 MHz**      **12.5 kHz**      **1.000 Watt(s) /Low Power**

Frequency (MHz)	Limit	Horizontal Measured Emission Equip Pwr Into Ideal Dipole (dBm)	Vertical Measured Emission Equip Pwr Into ideal Dipole (dBm)
900.0500	-20.0000	-76.6215 **	-75.1024 **
1350.0750	-20.0000	-61.7411 **	-60.6706 **
1800.1000	-20.0000	-58.5400 **	-59.0621 **
2250.1250	-20.0000	-56.9683 **	-56.7849 **
2700.1500	-20.0000	-55.0436 **	-54.9023 **
3150.1750	-20.0000	-50.8164 **	-53.3631 **
3600.2000	-20.0000	-52.0717 **	-52.0854 **
4050.2250	-20.0000	-50.9582 **	-50.6715 **
4500.2500	-20.0000	-49.3472 **	-50.0814 **

**RADIATED SPURIOUS EMISSIONS**

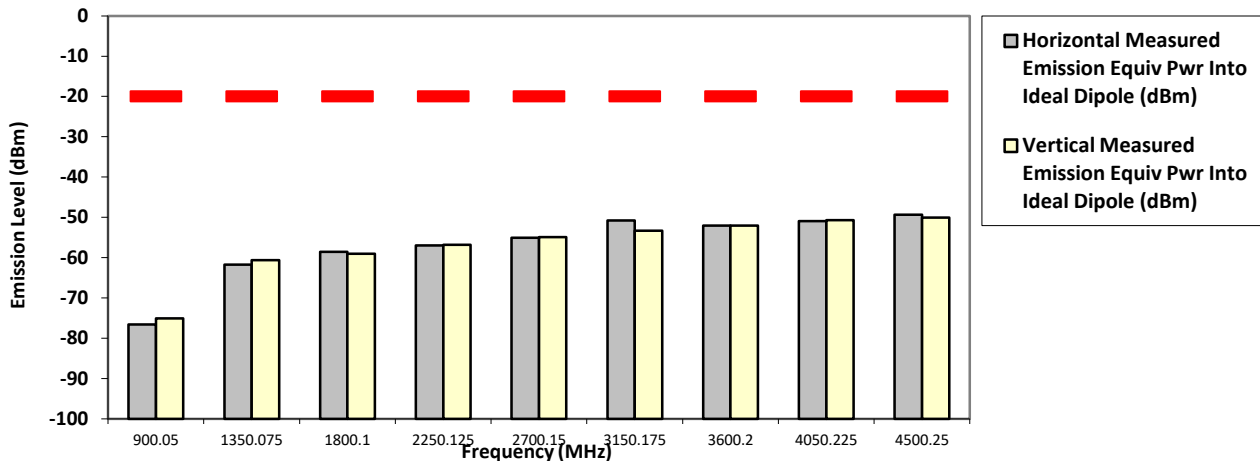

The data presented here was taken using the substitution method as found in the ANSI C63.26-2015 document.  
 Motorola Penang EMC Lab - Test Performed by: Nazrin & Rezza      Fri, 11 Aug, 2023

Remarks: \*\* Indicates the spurious emission could not be detected due to noise limitations or ambient.  
 \*Pursuant to CFR 47 Part 2.1057 ( c ), emissions attenuated more than 20 dB below the permissible limit are not reported  
 Temp(Deg): 23.4 Hum(%RH): 69.6

Remarks: Passed Results Marginal Results Failed Results

**SAC Transmitter Radiated Emission:**

**Model Number: H25XDF9PW6AN**      **S/N: 287TZP0060**      **SR:39809-EMC-00045**  
**Battery Part No: PMNN4813A**      **Accy Part No: NA**  
**Test Mode: TX APCO Digital Phase II**  
**450.025000 MHz**      **12.5 kHz**      **5.700 Watt(s) /Max Power**

Frequency (MHz)	Limit	Horizontal Measured Emission Equip Pwr Into Ideal Dipole (dBm)	Vertical Measured Emission Equip Pwr Into ideal Dipole (dBm)
900.0500	-20.0000	-76.5072 **	-75.4728 **
1350.0750	-20.0000	-60.1430 **	-60.7969 **
1800.1000	-20.0000	-58.5365 **	-59.7860 **
2250.1250	-20.0000	-57.3393 **	-56.4339 **
2700.1500	-20.0000	-55.6517 **	-54.2892 **
3150.1750	-20.0000	-51.6780 **	-52.3334 **
3600.2000	-20.0000	-52.9877 **	-51.3542 **
4050.2250	-20.0000	-51.3395 **	-50.5962 **
4500.2500	-20.0000	-49.6028 **	-49.2655 **

**RADIATED SPURIOUS EMISSIONS**

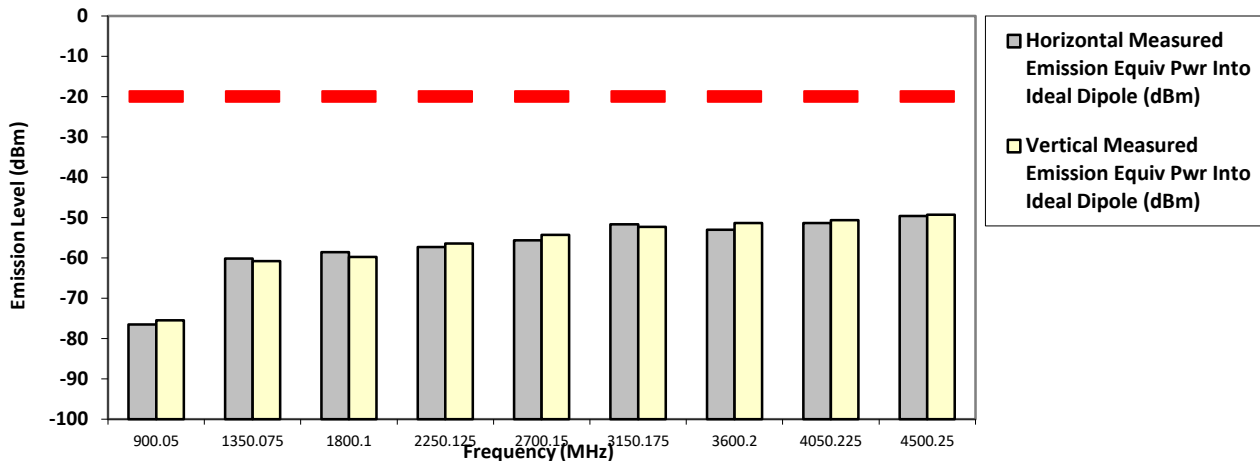

The data presented here was taken using the substitution method as found in the ANSI C63.26-2015 document.  
 Motorola Penang EMC Lab - Test Performed by: Nazrin & Rezza      Fri, 11 Aug, 2023

Remarks: \*\* Indicates the spurious emission could not be detected due to noise limitations or ambient.  
 \*Pursuant to CFR 47 Part 2.1057 ( c ), emissions attenuated more than 20 dB below the permissible limit are not reported  
 Temp(Deg): 23.4 Hum(%RH): 69.6

Remarks: Passed Results Marginal Results Failed Results

**SAC Transmitter Radiated Emission:**

**Model Number: H25XDF9PW6AN**      **S/N: 287TZP0060**      **SR:39809-EMC-00045**  
**Battery Part No: PMNN4813A**      **Accy Part No: NA**  
**Test Mode: TX APCO Digital Phase II**  
**459.125000 MHz**      **12.5 kHz**      **5.700 Watt(s) /Max Power**

Frequency (MHz)	Limit	Horizontal Measured Emission Equip Pwr Into Ideal Dipole (dBm)	Vertical Measured Emission Equip Pwr Into ideal Dipole (dBm)
918.2500	-20.0000	-76.0951 **	-75.5771 **
1377.3750	-20.0000	-59.9904 **	-60.3240 **
1836.5000	-20.0000	-59.0174 **	-58.3895 **
2295.6250	-20.0000	-57.1899 **	-55.1840 **
2754.7500	-20.0000	-54.7558 **	-54.9484 **
3213.8750	-20.0000	-52.8230 **	-51.1598 **
3673.0000	-20.0000	-52.4308 **	-52.3472 **
4132.1250	-20.0000	-49.4146 **	-51.2375 **
4591.2500	-20.0000	-50.8792 **	-50.1820 **

**RADIATED SPURIOUS EMISSIONS**

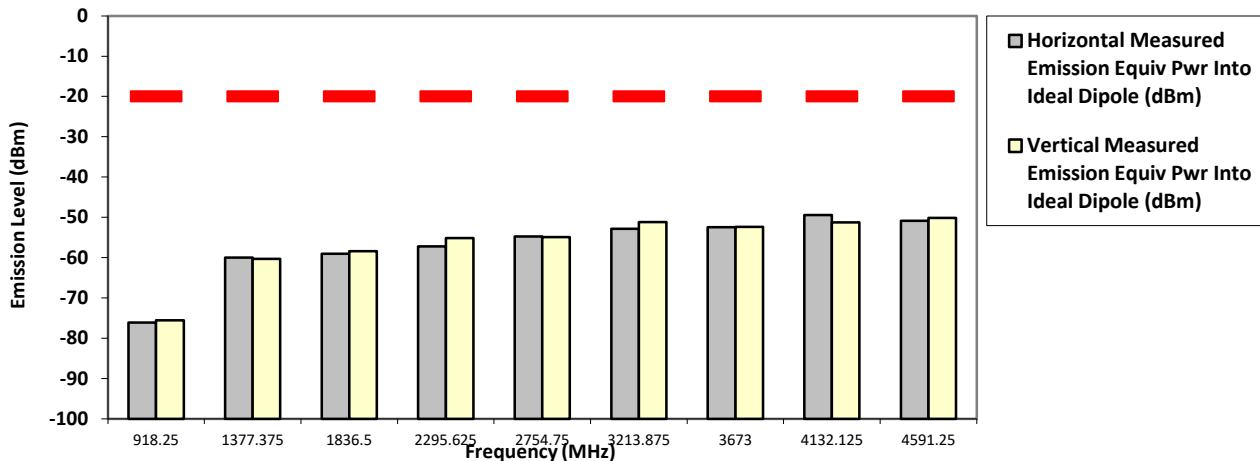

The data presented here was taken using the substitution method as found in the ANSI C63.26-2015 document.  
 Motorola Penang EMC Lab - Test Performed by: Nazrin & Rezza      Fri, 11 Aug, 2023

Remarks: \*\* Indicates the spurious emission could not be detected due to noise limitations or ambient.  
 \*Pursuant to CFR 47 Part 2.1057 ( c ), emissions attenuated more than 20 dB below the permissible limit are not reported  
 Temp(Deg): 23.4 Hum(%RH): 69.6

Remarks: Passed Results Marginal Results Failed Results

**SAC Transmitter Radiated Emission:**

**Model Number: H25XDF9PW6AN**      **S/N: 287TZP0060**      **SR:39809-EMC-00045**  
**Battery Part No: PMNN4813A**      **Accy Part No: NA**  
**Test Mode: TX APCO Digital Phase II**  
**467.775000 MHz**      **12.5 kHz**      **5.700 Watt(s) /Max Power**

Frequency (MHz)	Limit	Horizontal Measured Emission Equip Pwr Into Ideal Dipole (dBm)	Vertical Measured Emission Equip Pwr Into ideal Dipole (dBm)
935.5500	-20.0000	-74.6795 **	-75.9604 **
1403.3250	-20.0000	-60.1222 **	-60.9925 **
1871.1000	-20.0000	-58.4265 **	-58.9736 **
2338.8750	-20.0000	-56.6750 **	-56.4333 **
2806.6500	-20.0000	-53.2357 **	-54.4787 **
3274.4250	-20.0000	-53.3732 **	-52.0347 **
3742.2000	-20.0000	-51.6368 **	-52.0978 **
4209.9750	-20.0000	-50.9299 **	-50.9841 **
4677.7500	-20.0000	-49.2176 **	-47.9214 **

**RADIATED SPURIOUS EMISSIONS**

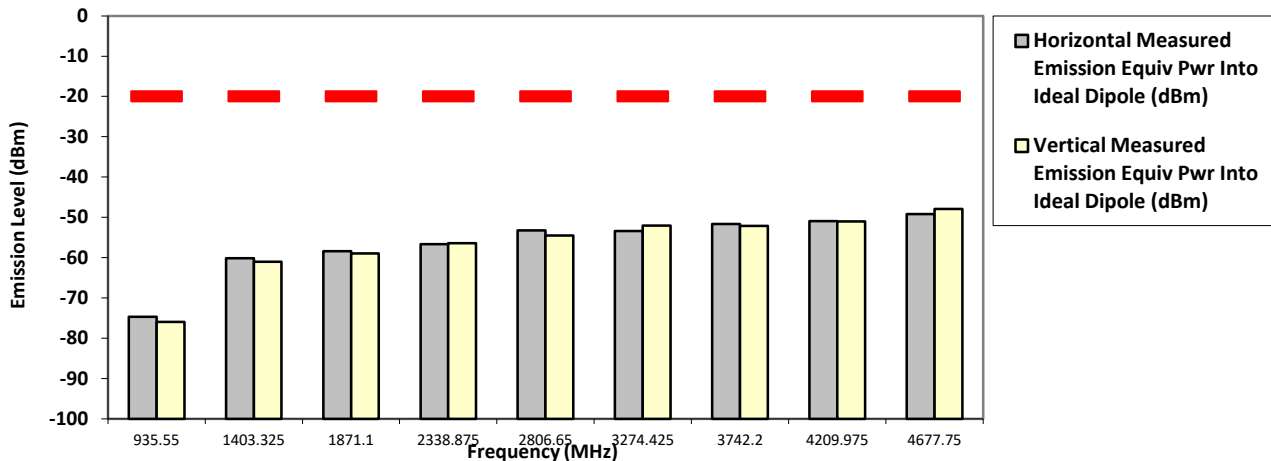

The data presented here was taken using the substitution method as found in the ANSI C63.26-2015 document.  
 Motorola Penang EMC Lab - Test Performed by: Nazrin & Rezza      Fri, 11 Aug, 2023

Remarks: \*\* Indicates the spurious emission could not be detected due to noise limitations or ambient.  
 \*Pursuant to CFR 47 Part 2.1057 ( c ), emissions attenuated more than 20 dB below the permissible limit are not reported  
 Temp(Deg): 23.4 Hum(%RH): 69.6

Remarks: Passed Results Marginal Results Failed Results

**SAC Transmitter Radiated Emission:**

**Model Number: H25XDF9PW6AN**      **S/N: 287TZP0060**      **SR:39809-EMC-00045**  
**Battery Part No: PMNN4813A**      **Accy Part No: NA**  
**Test Mode: TX APCO Digital Phase II**  
**482.012500 MHz**      **12.5 kHz**      **5.700 Watt(s) /Max Power**

Frequency (MHz)	Limit	Horizontal Measured Emission Equip Pwr Into Ideal Dipole (dBm)	Vertical Measured Emission Equip Pwr Into ideal Dipole (dBm)
964.0250	-20.0000	-74.0479 **	-74.4402 **
1446.0375	-20.0000	-59.7092 **	-60.5039 **
1928.0500	-20.0000	-57.1658 **	-58.2295 **
2410.0625	-20.0000	-55.0589 **	-55.5913 **
2892.0750	-20.0000	-54.6955 **	-55.1678 **
3374.0875	-20.0000	-52.9524 **	-51.5142 **
3856.1000	-20.0000	-50.8058 **	-49.7383 **
4338.1125	-20.0000	-50.8642 **	-49.6017 **
4820.1250	-20.0000	-48.1653 **	-48.6446 **

**RADIATED SPURIOUS EMISSIONS**

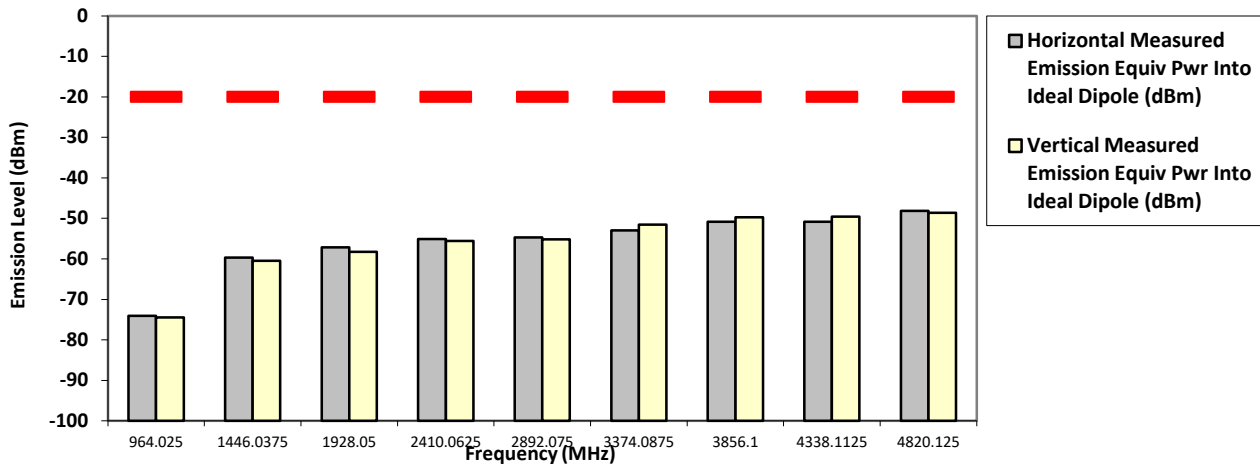

The data presented here was taken using the substitution method as found in the ANSI C63.26-2015 document.  
 Motorola Penang EMC Lab - Test Performed by: Nazrin & Rezza      Fri, 11 Aug, 2023

Remarks: \*\* Indicates the spurious emission could not be detected due to noise limitations or ambient.  
 \*Pursuant to CFR 47 Part 2.1057 ( c ), emissions attenuated more than 20 dB below the permissible limit are not reported  
 Temp(Deg): 23.4 Hum(%RH): 69.6

Remarks: Passed Results Marginal Results Failed Results



**SAC Transmitter Radiated Emission:**

**Model Number: H25XDF9PW6AN**      **S/N: 287TZP0060**      **SR:39809-EMC-00045**  
**Battery Part No: PMNN4813A**      **Accy Part No: NA**  
**Test Mode: TX APCO Digital Phase II**  
**511.987500 MHz**      **12.5 kHz**      **1.000 Watt(s) /Low Power**

Frequency (MHz)	Limit	Horizontal Measured Emission Equip Pwr Into Ideal Dipole (dBm)	Vertical Measured Emission Equip Pwr Into ideal Dipole (dBm)
1023.9750	-20.0000	-63.0774 **	-62.3793 **
1535.9625	-20.0000	-60.2188 **	-59.8366 **
2047.9500	-20.0000	-55.9550 **	-54.9139 **
2559.9375	-20.0000	-55.2185 **	-53.5109 **
3071.9250	-20.0000	-51.9826 **	-52.6602 **
3583.9125	-20.0000	-51.9945 **	-52.5637 **
4095.9000	-20.0000	-50.5119 **	-51.1012 **
4607.8875	-20.0000	-50.7170 **	-49.5383 **
5119.8750	-20.0000	-48.5863 **	-47.6461 **

**RADIATED SPURIOUS EMISSIONS**

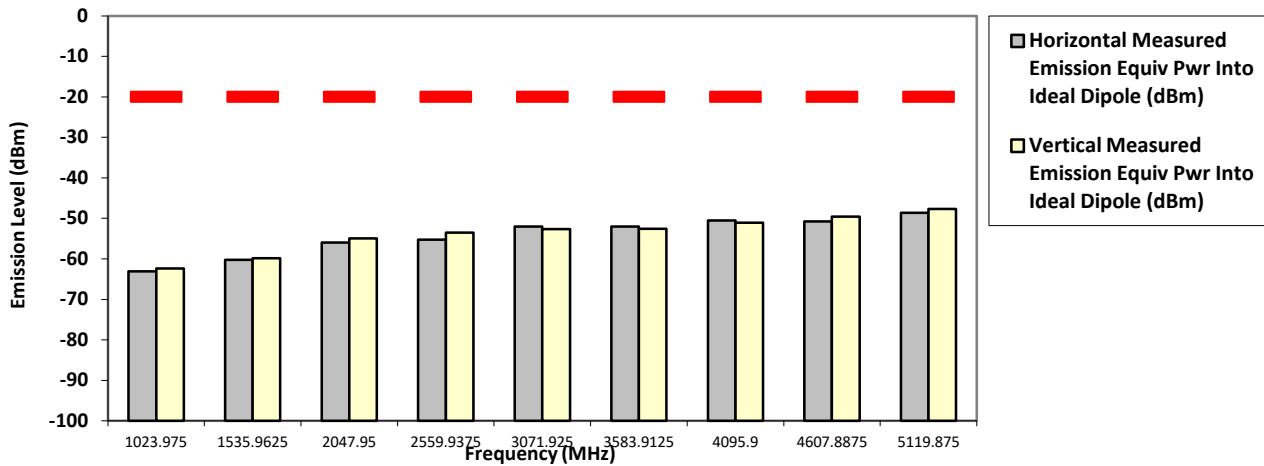

The data presented here was taken using the substitution method as found in the ANSI C63.26-2015 document.  
 Motorola Penang EMC Lab - Test Performed by: Nazrin & Rezza      Fri, 11 Aug, 2023

Remarks: \*\* Indicates the spurious emission could not be detected due to noise limitations or ambient.  
 \*Pursuant to CFR 47 Part 2.1057 ( c ), emissions attenuated more than 20 dB below the permissible limit are not reported  
 Temp(Deg): 23.4 Hum(%RH): 69.6

Remarks: Passed Results Marginal Results Failed Results

**SAC Transmitter Radiated Emission:**

**Model Number: H25XDF9PW6AN**      **S/N: 287TZP0060**      **SR:39809-EMC-00045**  
**Battery Part No: PMNN4813A**      **Accy Part No: NA**  
**Test Mode: TX APCO Digital Phase II**  
**511.987500 MHz**      **12.5 kHz**      **5.700 Watt(s) /Max Power**

Frequency (MHz)	Limit	Horizontal Measured Emission Equip Pwr Into Ideal Dipole (dBm)	Vertical Measured Emission Equip Pwr Into ideal Dipole (dBm)
1023.9750	-20.0000	-63.1947 **	-62.2527 **
1535.9625	-20.0000	-59.8605 **	-60.2350 **
2047.9500	-20.0000	-56.6688 **	-55.5144 **
2559.9375	-20.0000	-55.1249 **	-54.9830 **
3071.9250	-20.0000	-52.9849 **	-52.1080 **
3583.9125	-20.0000	-52.8092 **	-52.4413 **
4095.9000	-20.0000	-50.6695 **	-51.3919 **
4607.8875	-20.0000	-50.5759 **	-48.7140 **
5119.8750	-20.0000	-47.9310 **	-48.1129 **

**RADIATED SPURIOUS EMISSIONS**

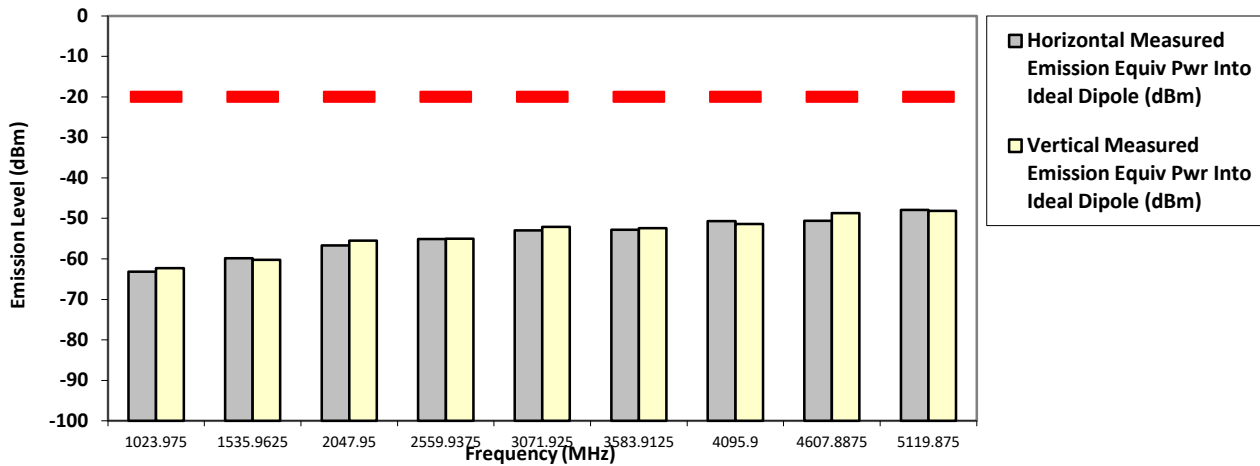

The data presented here was taken using the substitution method as found in the ANSI C63.26-2015 document.  
 Motorola Penang EMC Lab - Test Performed by: Nazrin & Rezza      Fri, 11 Aug, 2023

Remarks: \*\* Indicates the spurious emission could not be detected due to noise limitations or ambient.  
 \*Pursuant to CFR 47 Part 2.1057 ( c ), emissions attenuated more than 20 dB below the permissible limit are not reported  
 Temp(Deg): 23.4 Hum(%RH): 69.6

Remarks: Passed Results Marginal Results Failed Results

**SAC Transmitter Radiated Emission:**

**Model Number: H25XDF9PW6AN**      **S/N: 287TZP0060**      **SR:39809-EMC-00045**  
**Battery Part No: PMNN4813A**      **Accy Part No: NA**  
**Test Mode: TX APCO Digital Phase II**  
**519.987500 MHz**      **12.5 kHz**      **5.700 Watt(s) /Max Power**

Frequency (MHz)	Limit	Horizontal Measured Emission Equip Pwr Into Ideal Dipole (dBm)	Vertical Measured Emission Equip Pwr Into ideal Dipole (dBm)
1039.9750	-20.0000	-63.0478 **	-62.7638 **
1559.9625	-20.0000	-60.2366 **	-59.8772 **
2079.9500	-20.0000	-56.4107 **	-55.5440 **
2599.9375	-20.0000	-53.7989 **	-54.3966 **
3119.9250	-20.0000	-52.3214 **	-51.9046 **
3639.9125	-20.0000	-52.4427 **	-52.7088 **
4159.9000	-20.0000	-50.3382 **	-51.6493 **
4679.8875	-20.0000	-49.8504 **	-48.7885 **
5199.8750	-20.0000	-49.2440 **	-47.6407 **

**RADIATED SPURIOUS EMISSIONS**

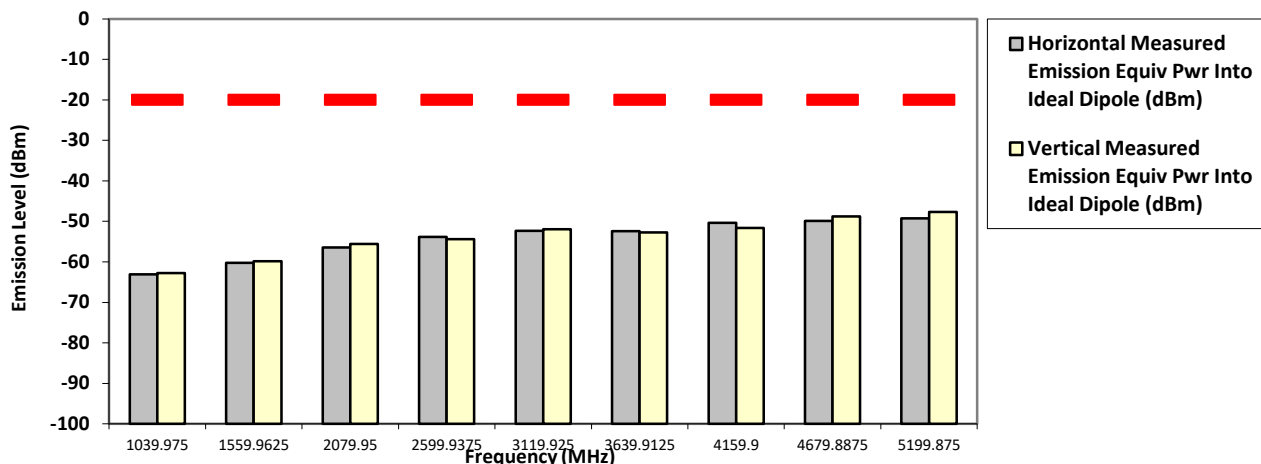

The data presented here was taken using the substitution method as found in the ANSI C63.26-2015 document.  
 Motorola Penang EMC Lab - Test Performed by: Nazrin & Rezza      Fri, 11 Aug, 2023

Remarks: \*\* Indicates the spurious emission could not be detected due to noise limitations or ambient.  
 \*Pursuant to CFR 47 Part 2.1057 ( c ), emissions attenuated more than 20 dB below the permissible limit are not reported  
 Temp(Deg): 23.4 Hum(%RH): 69.6

Remarks: Passed Results Marginal Results Failed Results

**6.10.4. Test Limit**

Table below summarized the power of any emission outside a licensee’s frequency block shall be attenuated below the transmitter power (P) by at least

Channel Spacing	Part 22	Part 24D	Part 74	Part 80	Part 90 (UHF, VHF, 800, 900)	Part 90 (700)
12.5kHz	43 + log <sub>10</sub> (P) (-13 dBm)	43 + log <sub>10</sub> (P) (-13 dBm)	43 + log <sub>10</sub> (P) (-13 dBm)	Not Applicable	50 + log <sub>10</sub> (P) (-20 dBm)	43 + log <sub>10</sub> (P) (-13 dBm)
25kHz		Not Applicable		43 + log <sub>10</sub> (P) (-13 dBm)	43 + log <sub>10</sub> (P) (-13 dBm)	43 + log <sub>10</sub> (P) (-13 dBm)

Channel Spacing	RSS 134	RSS 182	RSS 119 (UHF, VHF, 800, 900)	RSS 119 (700)
12.5kHz	43 + log <sub>10</sub> (P) (-13 dBm)	Not Applicable	50 + log <sub>10</sub> (P) (-20 dBm)	43 + log <sub>10</sub> (P) (-13 dBm)
25kHz	Not Applicable	43 + log <sub>10</sub> (P) (-13 dBm)	43 + log <sub>10</sub> (P) (-13 dBm)	43 + log <sub>10</sub> (P) (-13 dBm)

## 6.11. Effective Radiated Power (ERP)

### 6.11.1. Test Setup

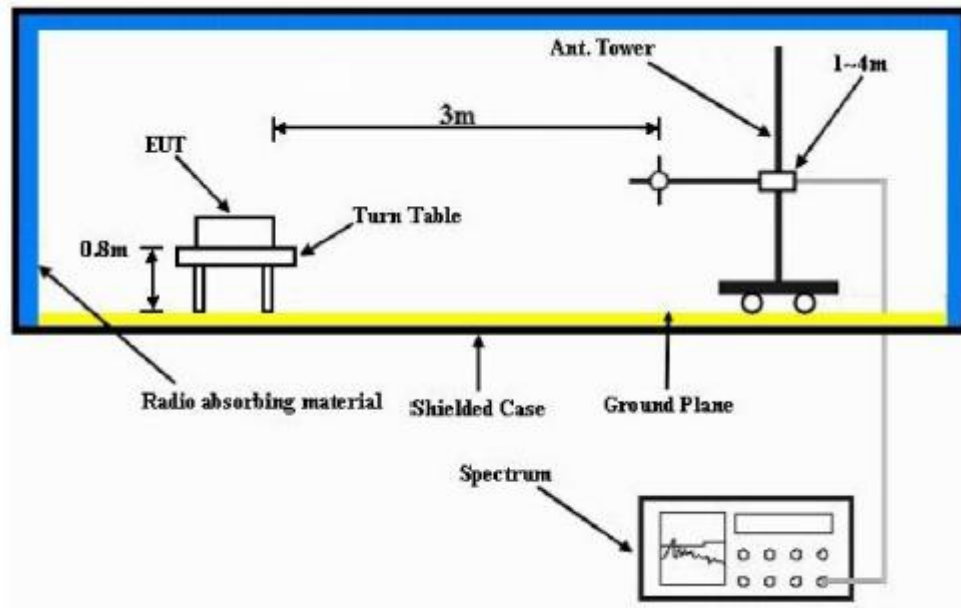

- 1) The Resolution Bandwidth for Equivalent Radiated Power (ERP) below 1 GHz is 100 kHz with Video Bandwidth = 300 kHz and Resolution Bandwidth for EIRP above 1 GHz is 1 MHz with Video Bandwidth = 3 MHz. Detector Mode is RMS.
- 2) In the semi-anechoic chamber, setup as illustrated above the DUT placed on the 0.8m height (for  $F_c < 1\text{GHz}$ ) or 1.5m (for  $F_c > 1\text{GHz}$ ) of Turn Table, rotated the table 45 degree each interval to search the maximum radiation power and receiver antenna shall be rotated vertical and horizontal polarization and moved height from 1m to 4m to find the maximum polar radiated power for each degree interval. The “Read Value” is the spectrum reading of maximum power value.
- 3) The substitution antenna is substituted for DUT at the same position and signals generator (S.G) export the CW signal to the substitution antenna via a TX cable. The receiver antenna shall be rotated vertical and horizontal polarization and moved height from 1m to 4m to find the maximum radiation power. Record the power level of maximum radiation power from spectrum. So, the Measured substitution value = Ref level of S.G + TX cables loss – Substituted Antenna Gain.

**6.11.2. Test Result**

**Part 80 EIRP/ERP**

SRID: 39809-EMC-00046  
S/N: 287TZP0060  
Channel Spacing: 25kHz  
Accessory: AN000452A01

Tx Measured Conducted Power: 2.000 Watts  
Modulation: Analog  
Battery: PMNN4813A

Antenna Polarization	Frequency (MHz)	EIRP (dBm)	ERP (dBm)	ERP (Watts)	Limit (Watts)	Result
Vert.	467.7750	34.78	32.63	1.8323	2	Pass

**6.11.3. Test Limit**

The maximum output power of the transmitter for mobile stations is 100 watts (20 dB). Power is given in terms of effective radiated power (ERP).

## 6.12. GNSS (EIRP for 1559 - 1610MHz)

### 6.12.1. Test Setup

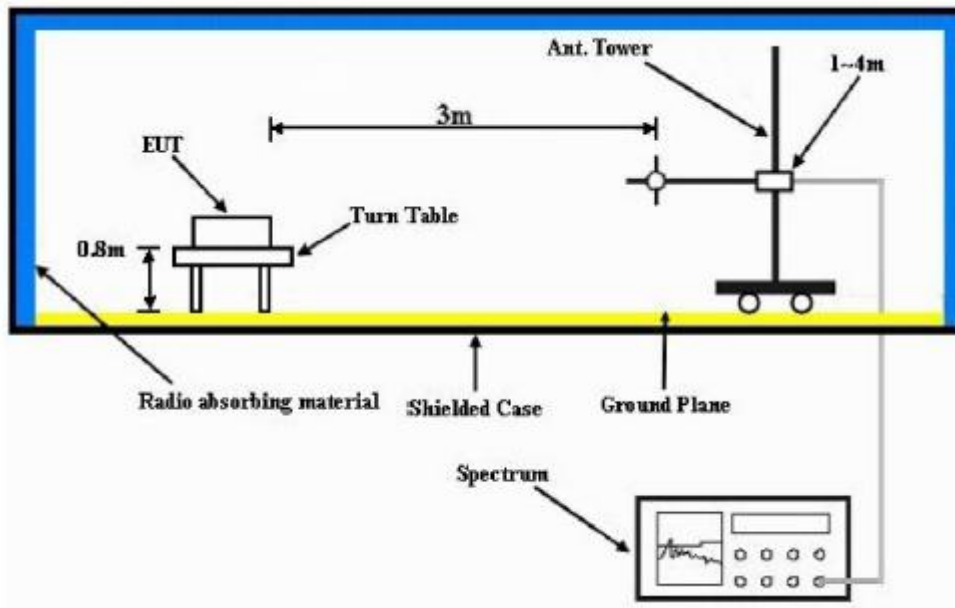

- 4) The Resolution Bandwidth for Equivalent Isotropically Radiated Power (EIRP) below 1 GHz is 100 kHz with Video Bandwidth = 300 kHz and Resolution Bandwidth for EIRP above 1 GHz is 1 MHz with Video Bandwidth = 3 MHz. Detector Mode is RMS.
- 5) In the semi-anechoic chamber, setup as illustrated above the DUT placed on the 0.8m height of Turn Table, rotated the table 45 degree each interval to search the maximum radiation power and receiver antenna shall be rotated vertical and horizontal polarization and moved height from 1m to 4m to find the maximum polar radiated power for each degree interval. The “Read Value” is the spectrum reading of maximum power value.
- 6) The substitution antenna is substituted for DUT at the same position and signals generator (S.G) export the CW signal to the substitution antenna via a TX cable. The receiver antenna shall be rotated vertical and horizontal polarization and moved height from 1m to 4m to find the maximum radiation power. Record the power level of maximum radiation power from spectrum. So, the Measured substitution value = Ref level of S.G + TX cables loss – Substituted Antenna Gain.
- 7)  $EIRP = \text{“Read Value”} + \text{Measured substitution value} + 2.15$ .

### 6.12.1. Test Result **Not Applicable**

### 6.12.2. Test Limit

For operations in the 758-775 MHz and 788-805 MHz bands, all emissions including harmonics in the band 1559-1610 MHz shall be limited to  $-70$  dBW/MHz equivalent isotropically radiated power (EIRP) for wideband signals, and  $-80$  dBW EIRP for discrete emissions of less than 700 Hz bandwidth.

~ End of Test Report ~