 <p>CERTIFICATE 2518.08</p> <p>MS ISO/IEC 17025 TESTING SAMM NO. 0825</p>
<p>MOTOROLA PENANG ADV. COMM. LABORATORY Motorola Solutions Malaysia SDN BHD, Plot 2A, Medan Bayan Lepas, Mukim 12 S.W.D, 11900 Bayan Lepas, Penang, Malaysia.</p>	<p>FCC/ISED TEST REPORT Report Revision : Rev.B</p>
<p>Date/s Tested : 07-FEB-2022 - 24-FEB-2022 Report Issue Date : 22-MAR-2022 Manufacturer : Motorola Solutions Malaysia SDN BHD Manufacturer Address : Plot 2A, Medan Bayan Lepas, Mukim 12 SWD, 11900 Bayan Lepas, Penang, Malaysia Requestor : ISMAIL, ABDUL HAKIM Product Type : Hand-held Product Version (PMN) : APX N50, APX N30 Model Number (HVIN) : H25UCF9PW6AN, H15UCF9PW6AN Frequency Band : 806-870MHz Max RF Output Power : 3.60 Watts Applicant Name : Motorola Solutions Inc Applicant Address : 8000 West Sunrise Boulevard, Fort Lauderdale, Florida 33322</p> <p>ISED Registrations : MY0001 FCC Registrations : 461337 Firmware Version (FVIN) : S27.50.08</p> <p>The equipment was tested accordance to the requirement listed below:</p> <p>(LMR) FCC 47 CFR Part 90 PASS ISED RSS- Gen Issue 5 / 119 Issue 12</p>	
<p>This report shall not be reproduced without written approval from an officially designated representative of the Motorola Penang Adv. Comm. Laboratory. The results and statements contained in this report pertain only to the device(s) evaluated.</p>	
<p>Prepared By:</p>  <p>_____ Putri Nur Sarah Sofia Test Personnel</p>	<p>Approved Signatory:</p> <p>_____ Soon Oi May Responsible Engineer</p>

Table of Contents

Report Revision History	3
1.0 General Information.....	4
2.0 Summary of Test Results.....	5
3.0 Measurement Uncertainty.....	6
4.0 Equipment List.....	7
5.0 Test Condition.....	10
5.1. Transmitter Test Conditions	10
6.0 Transmitter Test Parameters	11
6.1. RF Output Power	11
6.1.1. Test Setup.....	11
6.1.2. Test Result	11
6.2. Frequency Stability	12
6.2.1. Test Setup.....	12
6.2.2. Test Result	13
6.2.3. Test Limit.....	14
6.3. Audio Frequency Response	15
6.3.1. Test Setup.....	15
6.3.2. Test Result	16
6.3.3. Test Limit.....	17
6.4. Audio Low Pass Filter Response	18
6.4.1. Test Setup.....	18
6.4.2. Test Result	19
6.4.3. Test Limit.....	20
6.5. Modulation Limiting.....	21
6.5.1. Test Setup.....	21
6.5.2. Test Result	22
6.5.3. Test Limit.....	22
6.6. Occupied Bandwidth.....	23
6.6.1. Test Setup (Analog)	23
6.6.2. Test Result (Analog).....	24
6.6.3. Test Setup (Digital).....	39
6.6.4. Test Result (Digital).....	40
6.6.5. Test Limit.....	61
6.7. Band Edge Conducted Spurious Emission (Part 22)	62
6.7.1. Test Setup (Analog)	62
6.7.2. Test Result (Analog).....	62
6.7.3. Test Setup (Digital).....	63
6.7.4. Test Result (Digital).....	63
6.7.5. Test Limit.....	63
6.8. Transient Frequency Behavior.....	64
6.8.1. Test Setup.....	64
6.8.2. Test Result	64
6.8.3. Test Limit.....	65

6.9. Adjacent Channel Power..... 66

6.9.1. Test Setup (Analog) 66

6.9.2. Test Result 66

6.9.3. Test Setup (Digital)..... 67

6.9.4. Test Result 67

6.9.5. Test Limit..... 68

6.10. Conducted Spurious Emission 70

6.10.1. Test Setup..... 70

6.10.2. Test Result (Analog)..... 71

6.10.3. Test Result (Digital)..... 77

6.10.4. Test Limit..... 89

6.11. Radiated Spurious Emission 90

6.11.1. Test Setup..... 90

6.11.2. Test Result (Analog)..... 91

6.11.3. Test Result (Digital)..... 97

6.11.4. Test Limit..... 121

6.12. Effective Radiated Power (ERP) 122

6.12.1. Test Setup..... 122

6.12.2. Test Result 122

6.12.3. Test Limit..... 122

6.13. GNSS (EIRP for 1559 - 1610MHz)..... 123

6.13.1. Test Setup..... 123

6.13.1. Test Result 123

6.13.2. Test Limit..... 123

Report Revision History

Revision History	Description	Date	Originator
Rev. A	Initial Report	20-Mar-2022	Putri
Rev. B	Added sales model name for N50	22-Mar-2022	Putri

1.0 General Information

EUT Description:

Technologies	Land Mobile Radio (LMR)
Modulation Type	Analog, C4FM, Phase II

The EUT contains following accessory devices and data cable:

Item	Brand	Model or P/N
7/800 Whip Antenna (762-870MHz)	MOTOROLA	AN000411A01
BATT LIION IMPRES 2 IP68 2850T	MOTOROLA	PMNN4813A

General Description of Applied Standards

The EUT is a RF Product. According to the specifications of the manufacturer, the EUT is to comply with the requirements of the following standards:

ANSI C63.26-2015

No modifications were done to the UUT to facilitate the tests in this report.

Deviation from standard

Not applicable as no deviation from standard test method

Antenna gain disclaimer

Antenna gain information is provided by customer. The validity of the results is dependent upon this information. The lab will not be held accountable in the event the supplied information affects compliance.

Test configuration of EUT

All relevant configurations involving radio models and accessories (including chargers, batteries, and antennas) were assessed. Only worst case configurations will be included in this report.

2.0 Summary of Test Results

FCC General Rules Part (47CFR)	ISED General Rules Part	Test Item	Result	Remarks	Serial number tested
2.1046, 90.541	RSS-Gen, RSS-119	RF Power Output	Pass		657TYB0700
2.1055, 90.213	-	Frequency Stability	Pass		657TYB0700
2.1047	-	Audio Frequency Response	Pass		657TYB0700
2.1047	-	Audio Low Pass Filter Response	Pass		657TYB0700
2.1047	-	Modulation limiting	Pass		657TYB0700
2.1049, 90.210	RSS-119	Occupied Bandwidth	Pass	20K0F1E- 11.9244kHz 16K0F3E- 15.0102kHz 11K0F3E- 9.9360kHz 8K10F1D- 7.9473kHz 8K10F1E - 8.0429kHz 8K10F1W - 7.9332kHz	657TYB0700
-	-	Band Edge Conducted Spurious Emission	NA		
-	-	Transient Frequency Behavior	NA		
-	-	Adjacent Channel Power	NA		657TYB0700
2.1051, 90.210	RSS-Gen, RSS-119	Conducted Spurious Emissions	Pass	Worst Case - -29.23dBm	657TYB0700
2.1051, 90.210	RSS-Gen, RSS-119	Radiated Spurious Emission	Pass	Worst Case - -40.1788dBm, margin:20.1788dB (Noise floor)	657TYB0463, 657TYB0716
-	-	GNSS (EIRP for 1559 – 1610MHz)	NA		
-	-	Effective Radiated Power (ERP)	NA		

NA → Not Applicable

Note: Both N50 and N30 models are accessed and only the worst case results are presented in the report

3.0 Measurement Uncertainty

Measurement	Frequency	Expanded Uncertainty (k=1.96) (±)
AC Power Line Conducted Spurious Emission	150KHz ~ 30MHz	3.48 dB
Radiated Emissions up to 1 GHz dB μ V/m (Field Strength)	30MHz ~ 1000MHz	5.88 dB
Radiated Emissions above 1 GHz dB μ V/m (Field Strength)	1GHz ~ 18GHz	5.84 dB
	18GHz ~ 40GHz	6.02 dB
Radiated Emissions dBm (ERP/EiRP)	30MHz ~ 18GHz	4.03 dB
Conducted Spurious Emissions	9kHz ~ 12.75GHz	2.82 dB
Frequency Stability	9kHz ~ 12.75GHz	0.0085 ppm
Audio Frequency Response / Low Pass Filter Response	300Hz – 20kHz	4.09 %
Modulation Limiting	300Hz – 3kHz	1.15 %
Occupied Bandwidth	9kHz ~ 12.75GHz	2.82 dB
Band Edge Conducted Spurious Emission	9kHz ~ 12.75GHz	2.82 dB
Transient Frequency Behavior	9kHz ~ 12.75GHz	5.4 ms
Adjacent Channel Power	9kHz ~ 12.75GHz	2.82 dB

4.0 Equipment List

FCC Analog ATE#1: (SW version: 2.4.6 & FCC_Frequency Stability 1.0.3 rev.)

Description	Model	Serial Number	Calibration Date	Calibration Due Date
CHAMBER	SH-641	92009188	08-Mar-21	08-Mar-22
SWITCH CONTROL SYSTEM	3499B	CN40150337	CNR	CNR
POWER SENSOR	E4412A	MY41502652	09-Sep-21	09-Sep-22
POWER SUPPLY	6032A	3232A08203	14-Jun-21	14-Jun-22
POWER METER	E4416A	GB41293240	14-Mar-21	14-Mar-22
SIGNAL GENERATOR	2042	203003/061	07-Sep-21	07-Sep-22
ANALYZER SIGNAL (DYNAMIC)	35670A	MY42506847	17-Sep-21	17-Sep-22
MODULATION ANALYZER	8901B	3403A04974	06-Sep-21	06-Sep-22
N to N RF Cable # 1	M17/128-RG400	NA	NA	NA
BNC to N RF Cable # 1	RG 58	NA	NA	NA
BNC to BNC RF Cable # 1	RG 58	NA	NA	NA
BNC to BNC RF Cable # 2	RG 58	NA	NA	NA
BNC to BNC RF Cable # 3	RG 58	NA	NA	NA
BNC to BNC RF Cable # 4	RG 58	NA	NA	NA
BNC to BNC RF Cable # 5	RG 58	NA	NA	NA
BNC to BNC RF Cable # 6	RG 58	NA	NA	NA
BNC to BNC RF Cable # 7	RG 58	NA	NA	NA
N to SMA RF Cable # 1	RG 58	NA	NA	NA
N to SMA RF Cable # 2	RG 58	NA	NA	NA
N to SMA RF Cable # 3	RG 58	NA	NA	NA
Aeroflex Attenuator 30dB	49-30-34-LIM	NA	NA	NA

FCC Transient ATE #1: (SW version: FCC Transient ATE_R1.1.3)

Description	Model	Serial Number	Calibration Date	Calibration Due Date
SWITCH CONTROL UNIT	3488A	2719A36210	CNR	CNR
ATTENUATOR / SWITCH DRIVER	11713A	2508A10141	CNR	CNR
POWER SENSOR	E9301B	MY41495393	15-May-21	15-May-22
SIGNAL GENERATOR	8657A	3039A02769	11-Jun-21	11-Jun-22
AUDIO ANALYZER	8903B	3011A10318	01-Nov-21	01-Nov-22
POWER METER	E4416A	MY45101448	21-Jun-21	21-Jun-22
STEP ATTENUATOR	8494G	MY52300967	17-Jun-21	17-Jun-22
POWER SUPPLY	6033A	3004A04987	08-Jul-21	08-Jul-22
ANALYZER SPECTRUM	E4445A	MY46181732	29-Jun-21	29-Jun-22
ATTENUATOR/110DB	8496G	MY52300176	22-Aug-21	22-Aug-22
AUDIO ANALYZER	8903B	3413A14586	13-Sep-21	13-Sep-22
ANALYZER MODULATION	8901B	2619A00845	30-Sep-21	30-Sep-22
AUDIO ANALYZER	8903B	3011A12488	13-Sep-21	13-Sep-22
N to N RF Cable # 1	SF126/11N/11N	NA	NA	NA
N to N RF Cable # 1	SF126/11N/11N	NA	NA	NA
N to N RF Cable # 2	M17/128-RG400	NA	NA	NA
N to N RF Cable # 3	M17/128-RG400	NA	NA	NA
N to N RF Cable # 4	M17/128-RG400	NA	NA	NA
N to N RF Cable # 5	M17/128-RG400	NA	NA	NA
N to N RF Cable # 6	M17/128-RG400	NA	NA	NA
N to N RF Cable # 7	M17/128-RG400	NA	NA	NA
N to N RF Cable # 8	M17/128-RG400	NA	NA	NA
N to N RF Cable # 9	M17/128-RG400	NA	NA	NA
BNC to BNC RF Cable # 1	RG 58	NA	NA	NA
BNC to BNC RF Cable # 2	RG 58	NA	NA	NA
BNC to BNC RF Cable # 3	RG 58	NA	NA	NA
BNC to BNC RF Cable # 4	RG 58	NA	NA	NA
BNC to BNC RF Cable # 5	RG 58	NA	NA	NA
BNC to BNC RF Cable # 6	RG 58	NA	NA	NA
BNC to N RF Cable # 1	RG 58	NA	NA	NA
Aeroflex Attenuator 10dB	49-10-43-LIM	NA	NA	NA
Aeroflex Attenuator 10dB	33-10-34-LIM	NA	NA	NA

FCC CONDUCTED SPUR EMISSION ATE # 1 (SW version: Conducted Spur ATE_rev 1.23.03)

Description	Model	Serial Number	Calibration Date	Calibration Due Date
SWITCH CONTROL UNIT	3488A	2719A32735	CNR	CNR
ANALYZER SPECTRUM	E4440A	MY48250517	21-Dec-21	21-Dec-22
POWER SUPPLY	6031A	3221A02613	25-May-21	25-May-22
INTERFACE BOX - FILTER	CNR	CS001	06-Jul-21	06-Jul-22
N to N RF Cable # 1	SF126/11N/11N	NA	NA	NA
N to N RF Cable # 2	SF126/11N/11N	NA	NA	NA
BNC to BNC RF Cable # 1	RG 58	NA	NA	NA
Aeroflex Attenuator 30dB	49-30-43-LIM	NA	NA	NA
Aeroflex Attenuator 10dB	33-10-34-LIM	NA	NA	NA

EMC Chamber 1

DESCRIPTION	MODEL	SERIAL NUMBER	CALIBRATION DATE	CALIBRATION DUE DATE
DRG HORN FREQ.	SAS-571	720	06-Apr-21	06-Apr-23
DRG HORN FREQ.	SAS-571	719	13-Sep-21	13-Sep-22
POWER SUPPLY	N7976A	MY53410110	24-May-21	24-May-22
SIGNAL GENERATOR	SMB 100A	182511	4-Jun-21	4-Jun-24
EMI TEST RECEIVER	ESW44	101731	5-Nov-21	5-Nov-22
EMI TEST RECEIVER	ESIB26	827769/009	11-Mar-21	11-Mar-22
5m SEMI-ANECHOIC CHAMBER	S800-HX	J2308	No Cal. Req'd	No Cal. Req'd
BILOG ANTENNA	CBL6112D	55546	06-Jun-21	06-Jun-22
BILOG ANTENNA	CBL6112B	2964	4-May-21	4-May-22
HYGRO-THERMOMETER	SDL500	A.016800	18-May-21	18-May-22
SYSTEM CONTROLLER	SC104V	050806-1	No Cal. Req'd	No Cal. Req'd
TURNTABLE FLUSH MOUNT 2M	FM2011	NA	No Cal. Req'd	No Cal. Req'd
ANTENNA POSITIONING TOWER	TLT2	NA	No Cal. Req'd	No Cal. Req'd
BROAD-BAND HORN ANTENNA	BBHA9170	BBHA9170143	3-Aug-21	3-Aug-22
PREAMPLIFIER 18-40GHz	BBV9721	9721-007	No Cal. Req'd	No Cal. Req'd
PREAMPLIFIER	PAM-0118P	361	11-Sep-20	11-Sep-23
LOOP ANTENNA	6502	00208416	8-Oct-21	8-Oct-22
TEST SOFTWARE	EMC FCC IC BLUETOOTH RE TEST			
VERSION	EMC FCC RE_v1.6.2			

5.0 Test Condition

5.1. Transmitter Test Conditions

Test Item, (Channel Spacing)	Power (W)	Modulation	Test Frequency (MHz)	Tested By	Environmental conditions
RF Output Power	Low & Max	Analog	806.0125, 814.9875, 823.9875, 851.0125, 860.0125, 868.8875	Putri	23.4°C, 50%RH
Frequency Stability	Max	Analog	823.9875	Putri	25.1°C, 54.3%RH, 60.3°C, 50%RH, -30.1°C, 51.2%RH
Audio Frequency Response (12.5kHz / 25kHz)	Max	Analog	823.9875	Putri	23.4°C, 50%RH
Audio Low Pass Filter Response (12.5kHz / 25kHz)	Max	Analog	823.9875	Putri	23.4°C, 50%RH
Modulation limiting (12.5kHz / 25kHz)	Max	Analog	823.9875	Putri	23.4°C, 50%RH
Occupied Bandwidth (12.5kHz / 20kHz / 25kHz)	Max	Analog, C4FM, Phase II	806.0125, 814.9875, 823.9875, 851.0125, 860.0125, 868.8875, 853.9875	Putri	23.4°C, 50%RH
Band Edge Conducted Spurious Emissions (Part 22) (12.5kHz / 20kHz / 25kHz)	Max	Analog, C4FM, Phase II	NA		
Transient Frequency Behavior (UHF & VHF Band) (12.5kHz / 25kHz)	Max	Analog, C4FM, Phase II	NA		
Adjacent Channel Power (700MHz Band) (12.5kHz / 25kHz)	Max	Analog, C4FM, Phase II	NA		
Conducted Spurious Emissions- (12.5kHz / 25kHz)	Low / Max	Analog, C4FM, Phase II	806.0125, 814.9875, 823.9875, 851.0125, 860.0125, 868.8875	Putri	23.4°C, 50%RH
Radiated Spurious Emission (12.5kHz / 25kHz)	Low / Max	Analog, C4FM, Phase II	806.0125, 814.9875, 823.9875, 851.0125, 860.0125, 868.8875	Nazrin, Qawiman&Azil	23.3°C 69.4%RH
GNSS (EIRP for 1559 - 1610MHz) (12.5kHz / 25kHz)	Max	Analog	NA		
Effective Radiated Power (ERP) (12.5kHz / 25kHz)	Max	Analog	NA		

NA → Not Applicable

6.0 Transmitter Test Parameters

6.1. RF Output Power

6.1.1. Test Setup

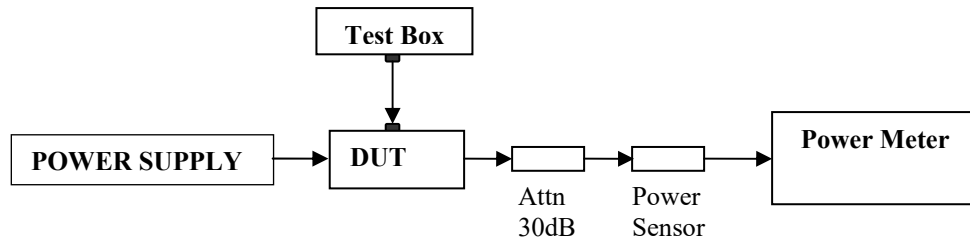

- 1) The DUT transmitter connected to Power Meter using the 30 dB attenuator and power sensor with above setup.
- 2) Path loss for the measurement included.
- 3) All the measurement was done at low, mid, high frequency for each band.
- 4) Record the power into the test report.

6.1.2. Test Result

Temperature	25°C			
Voltage (V)	7.5V			
Frequency (MHz)	Low Power (W)	Current (A)	Max Power (W)	Current (A)
806.01250	1.04	1.03	3.58	1.70
814.98750	1.03	1.06	3.57	1.70
823.98750	1.03	1.03	3.57	1.73
851.01250	1.04	1.03	3.58	1.70
860.01250	1.03	1.00	3.53	1.69
868.88750	1.04	1.06	3.54	1.70

6.2. Frequency Stability

6.2.1. Test Setup

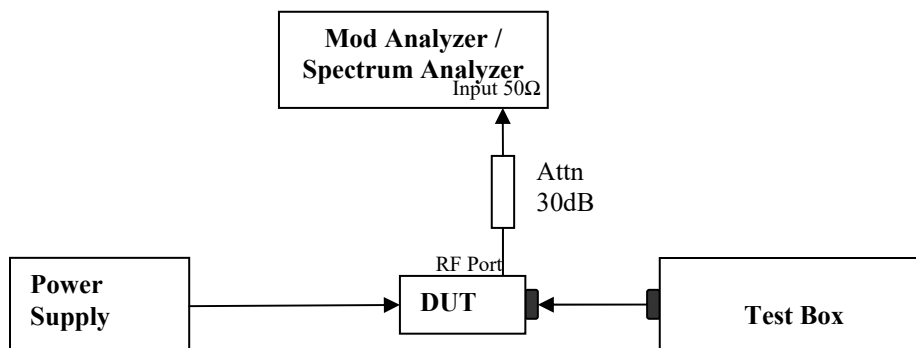

- 1) The DUT transmitter output port was connected to Modulation / Spectrum Analyzer.
- 2) Path loss for the measurement included.
- 3) Transmit the DUT and record the freq in MCF_{MHz} .
- 4) Test in 2 conditions:
 - Temperature: The frequency of the transmitter was measured from $-30^{\circ}C$ to $50^{\circ}C$.
 - Supply Voltage:
 - Mobile: The frequency of the transmitter was measured from 85% to 115% of the nominal operating input voltage.
 - Portable: The frequency of the transmitter was measured from nominal $\pm x\%$ as specified by the manufacturer
- 5) Calculate the ppm frequency error by the following:

$$ppm\ error = \left(\frac{MCF_{MHz}}{ACF_{MHz}} - 1 \right) * 10^6$$

Where: MCF_{MHz} is the Measured Carrier Frequency in MHz
 ACF_{MHz} is the Assigned Carrier Frequency in MHz

6.2.2. Test Result

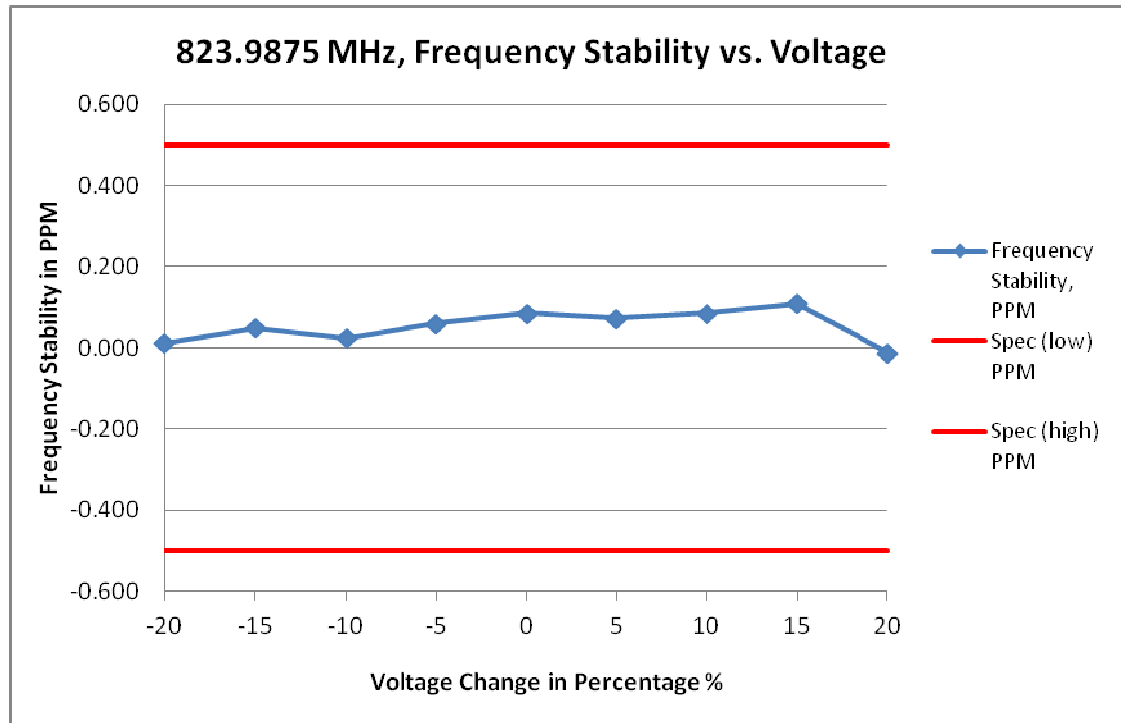

(i) Frequency Stability VS Voltage

Frequency / Channel Spacing	823.9875 MHz / 12.5 kHz				
Temperature, °C	25				
Voltage %	Voltage, V	Frequency, MHz	Frequency Stability, PPM	Spec (low) PPM	Spec (high) PPM
-20	6.000	823.987510	0.012	-0.500	0.500
-15	6.370	823.987540	0.049	-0.500	0.500
-10	6.750	823.987520	0.024	-0.500	0.500
-5	7.120	823.987550	0.061	-0.500	0.500
0	7.500	823.987570	0.085	-0.500	0.500
5	7.870	823.987560	0.073	-0.500	0.500
10	8.250	823.987570	0.085	-0.500	0.500
15	8.620	823.987590	0.109	-0.500	0.500
20	9.000	823.987490	-0.012	-0.500	0.500

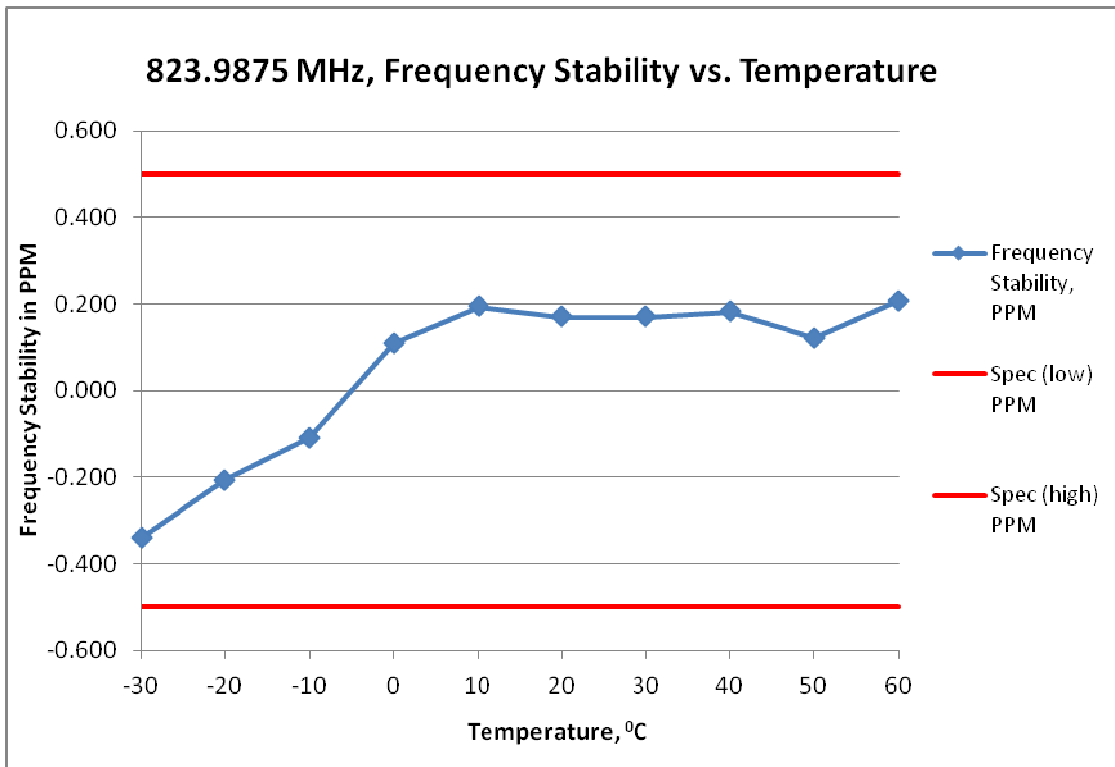

(ii) Frequency Stability VS temperature

Frequency / Channel Spacing	823.9875 MHz / 12.5 kHz			
Voltage, V	7.5			
Temperature, °C	Frequency, MHz	Frequency Stability, PPM	Spec (low) PPM	Spec (high) PPM
-30	823.987220	-0.340	-0.500	0.500
-20	823.987330	-0.206	-0.500	0.500
-10	823.987410	-0.109	-0.500	0.500
0	823.987590	0.109	-0.500	0.500
10	823.987660	0.194	-0.500	0.500
20	823.987640	0.170	-0.500	0.500
30	823.987640	0.170	-0.500	0.500
40	823.987650	0.182	-0.500	0.500
50	823.987600	0.121	-0.500	0.500
60	823.987670	0.206	-0.500	0.500

6.2.3. Test Limit

As per manufacturer declared spec +/- 0.5ppm

6.3. Audio Frequency Response

6.3.1. Test Setup

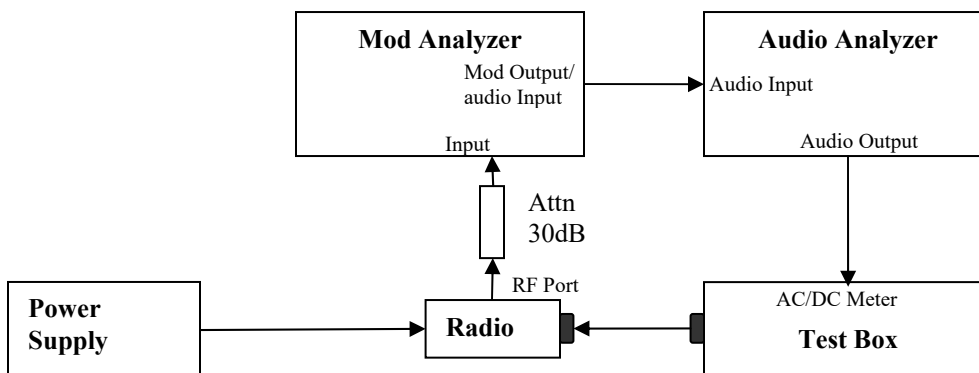

- 1) The DUT transmitter output port was connected to Modulation Analyzer.
- 2) Path loss for the measurement included.
- 3) Set the audio bandwidth filter to 15 kHz and 50 kHz.
- 4) Transmit the radio and set the audio analyzer to 1 kHz audio frequency and 20% of the Full rated system deviation.
- 5) On audio analyzer, set the rated level as reference to zero.
- 6) Vary the audio frequency from 300 Hz to 3 kHz. Record the change in dB on the audio analyzer.

6.3.2. Test Result

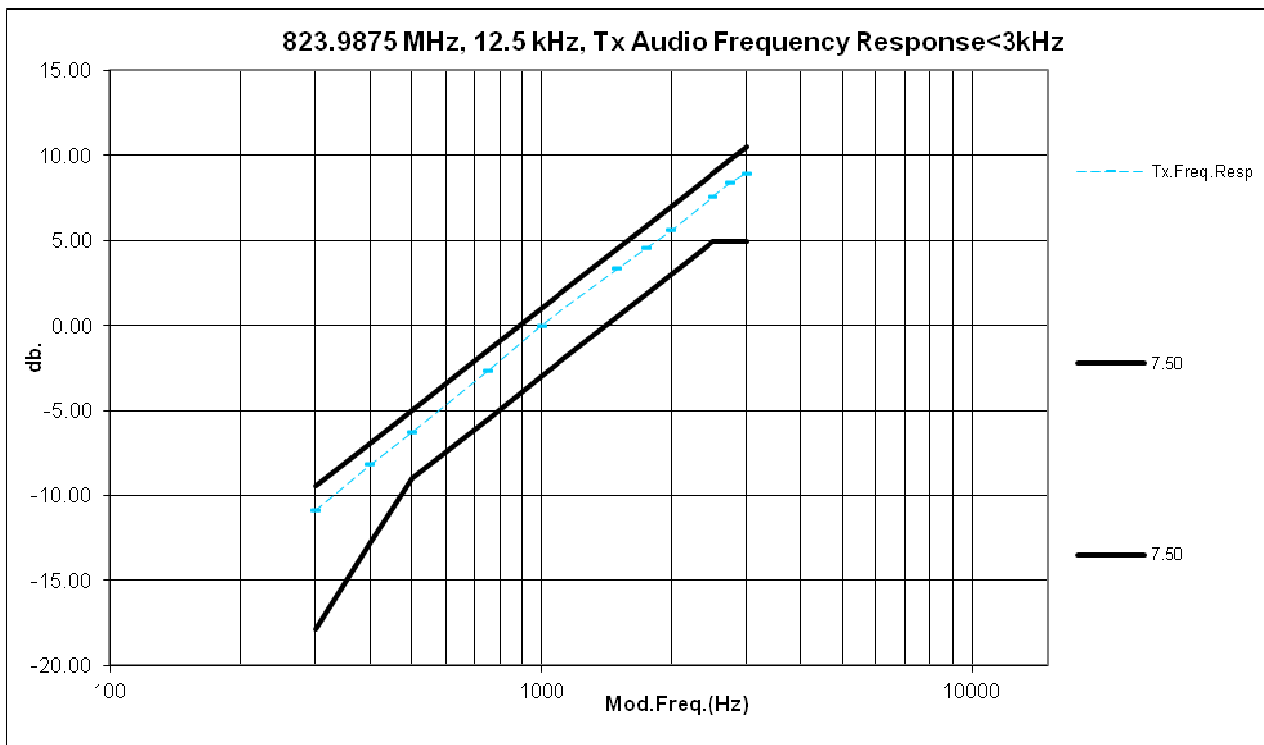
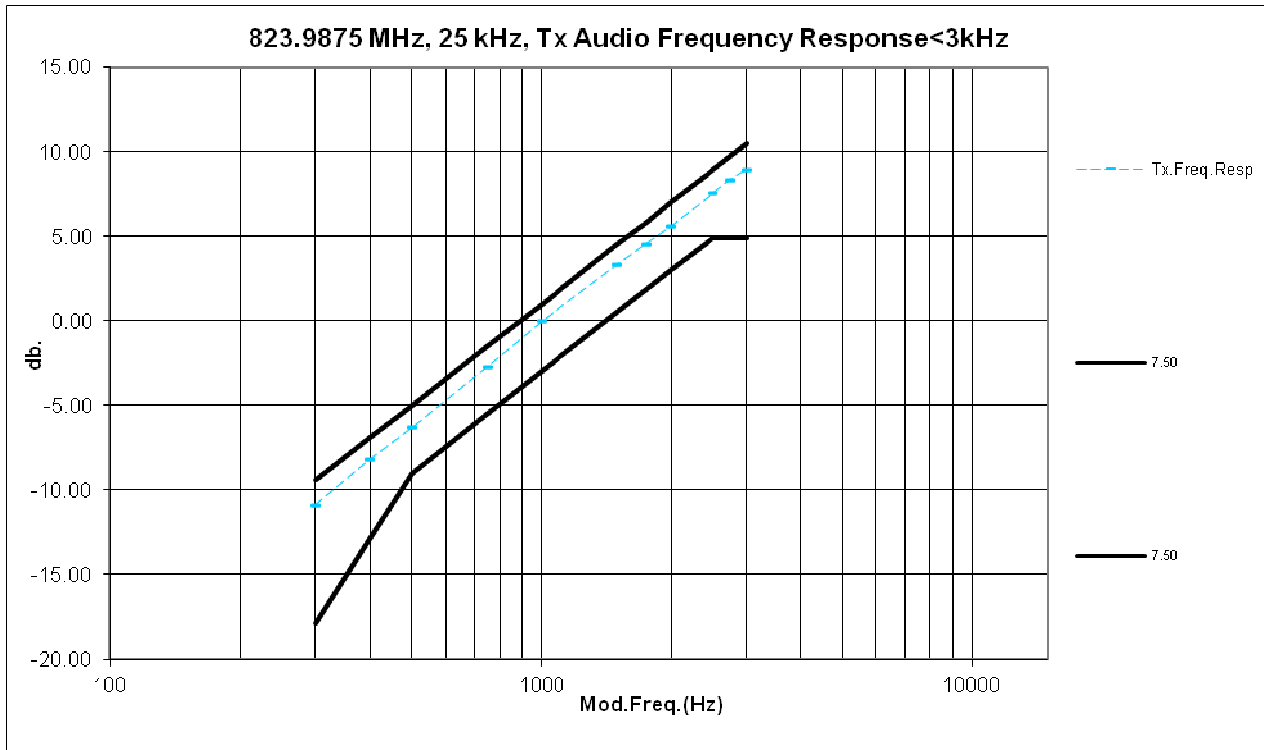

6.3.3. Test Limit

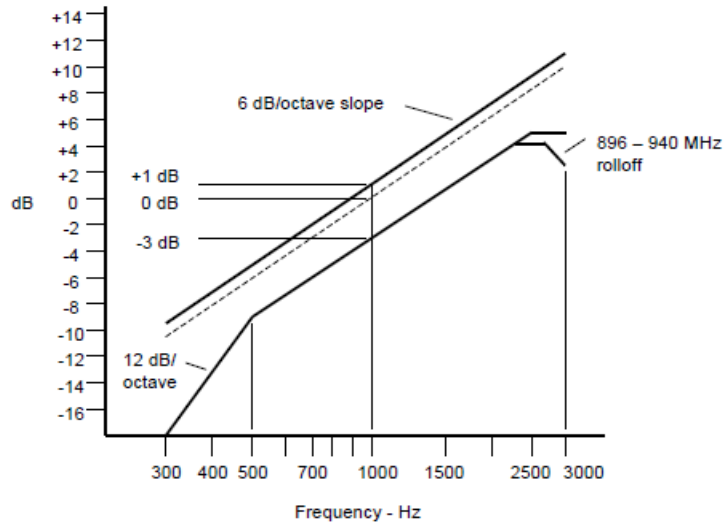

Note:

- o There are additional 6 dB per octave attenuation is allowed from 2.5KHz to 3KHz in equipment 25MHz to 869MHz radio.
- o Additional 6 dB per octave attenuation is allowed from 2.3KHz to 2.7KHz & additional 12 dB per octave attenuation is allowed from 2.7KHz to 3KHz in equipment 896MHz to 940MHz radio.

6.4. Audio Low Pass Filter Response

6.4.1. Test Setup

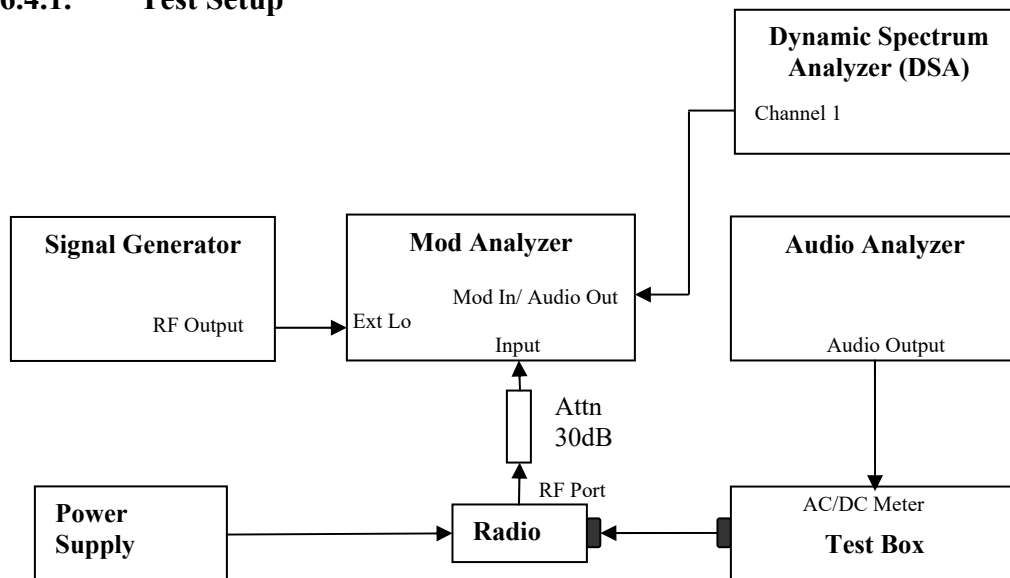

- 1) The DUT transmitter output port was connected to Modulation Analyzer.
- 2) Path loss for the measurement included.
- 3) Press 23.1SPCL on modulation analyzer to enable the external LO from Sigen.
- 4) Set the Sigen frequency to $F_c + 1.5$ MHz, RF output level to 0dBm without modulation.
- 5) Transmit the radio and set the audio analyzer to 1 kHz audio frequency and 60% of the Full rated system deviation.
- 6) Up the amplitude by 20dB.
- 7) On DSA, get the reference point to 0dB.
- 8) Vary the frequency on audio analyzer from 3 kHz to 20 kHz, record the audio tone from DSA.

6.4.2. Test Result

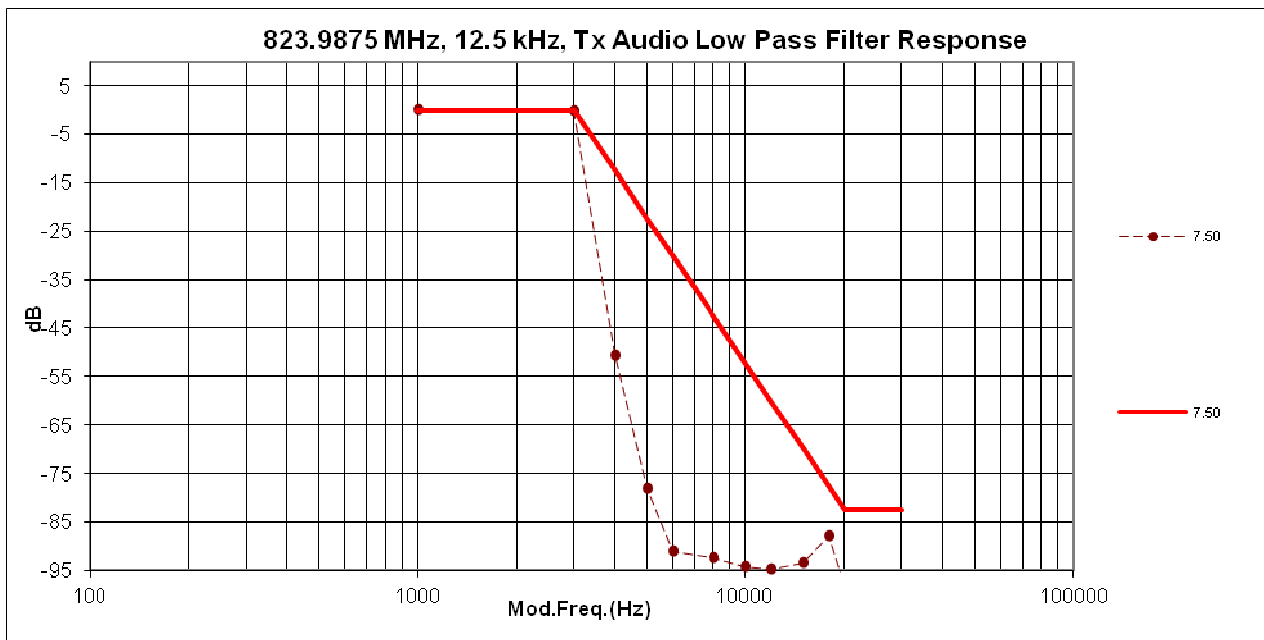
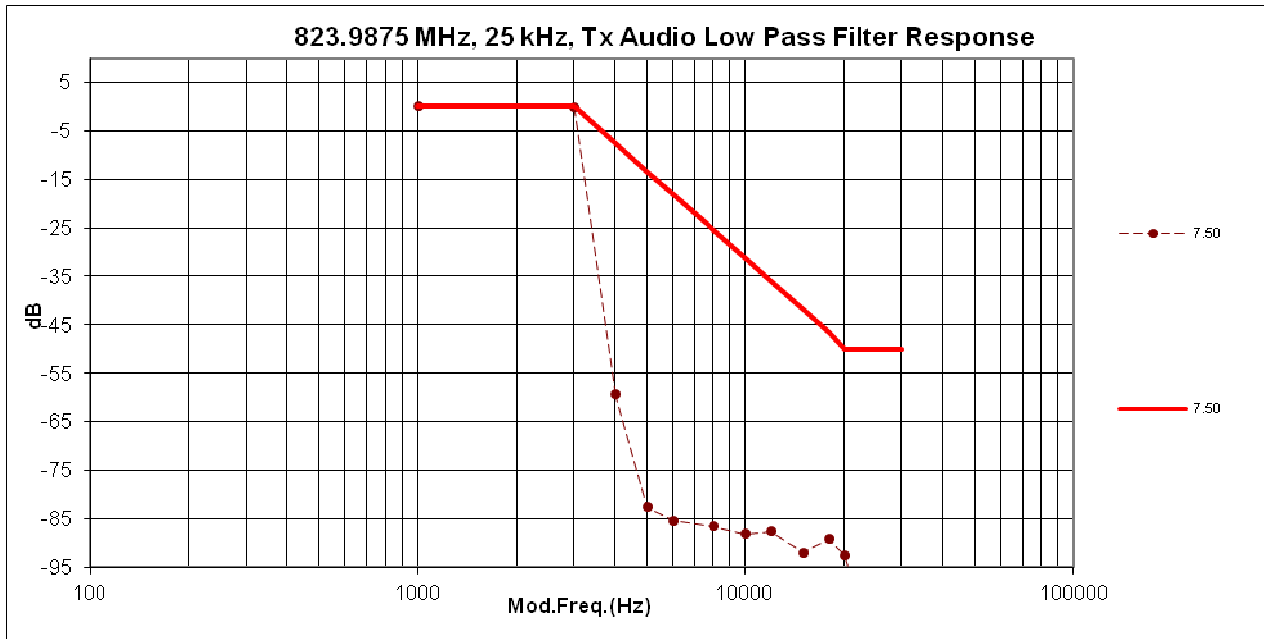

6.4.3. Test Limit

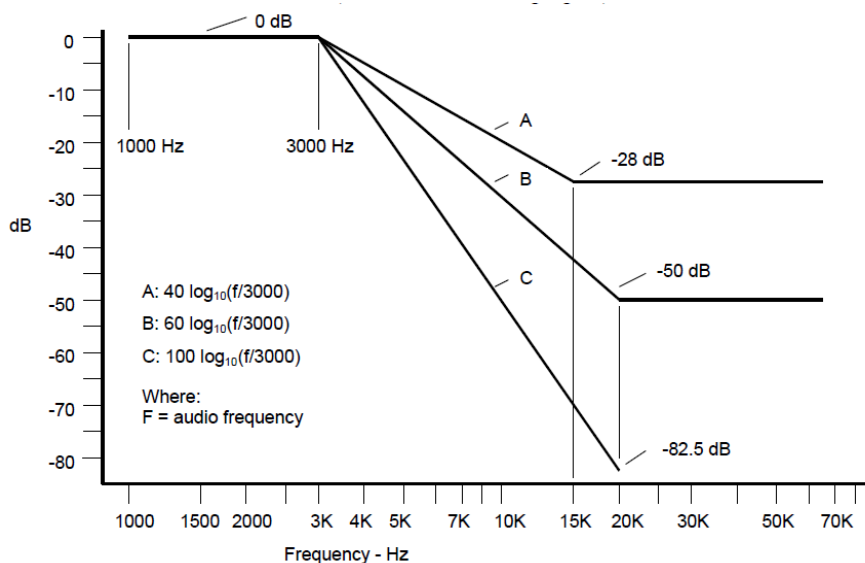

For audio frequencies above 3000 Hz, the audio response of the post limiter low-pass filter shall meet or exceed the following requirements:

- a) For equipment operating on 20, 25 or 30 kHz channel bandwidth in the 25 MHz to 174 MHz range:

At frequencies from 3000 Hz through 15,000 Hz the attenuation shall be greater than the attenuation at 1000 Hz by at least: $40 \log_{10}(f/3000)$ dB

where: f is the audio frequency in Hz.

At frequencies above 15,000 Hz, the attenuation shall be greater than the attenuation at 1000 Hz, by at least: 28 dB.

- b) For equipment operating with 25 kHz bandwidth channels between 406 and 512 MHz through 896 MHz, and between 929 MHz through 930 MHz:

At frequencies from 3000 Hz through 20,000 Hz, the attenuation shall be greater than the attenuation at 1000 Hz by at least: $60 \log_{10}(f/3000)$ dB

where: f is the audio frequency in Hz.

At frequencies above 20,000 Hz the attenuation shall be greater than the attenuation at 1000 Hz by at least: 50 dB.

- c) For equipment operating on channels between 896 MHz through 901 MHz, between 935 MHz through 940 MHz, and 12.5 or 15 kHz spaced channels in the frequency range 138-174 MHz and 406-512 MHz.

At frequencies from 3000 Hz through 20,000 Hz the attenuation shall be greater than the attenuation at 1000 Hz by at least: $100 \log_{10}(f/3000)$ dB

where: f is the audio frequency in Hz.

6.5. Modulation Limiting

6.5.1. Test Setup

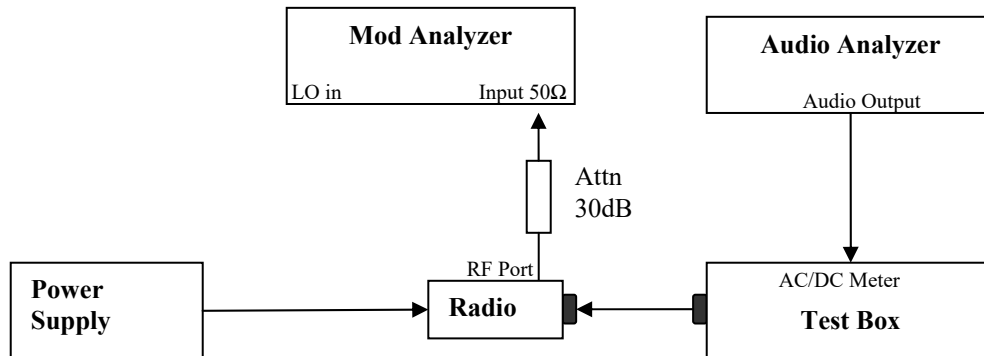

- 1) The DUT transmitter output port was connected to Modulation Analyzer.
- 2) Path loss for the measurement included.
- 3) Set the audio bandwidth filter to 15 kHz.
- 4) Transmit the radio and set the audio analyzer to 1 kHz audio frequency and 60% of the Full rated system deviation.
- 5) Record the frequency deviation as 0dB input level at 1kHz audio frequency.
- 6) Repeat the step and record the frequency deviation from -20 dB to 20dB by 5 dB increments and different audio freq 300 Hz, 2.5 kHz and 3 kHz.

6.5.2. Test Result

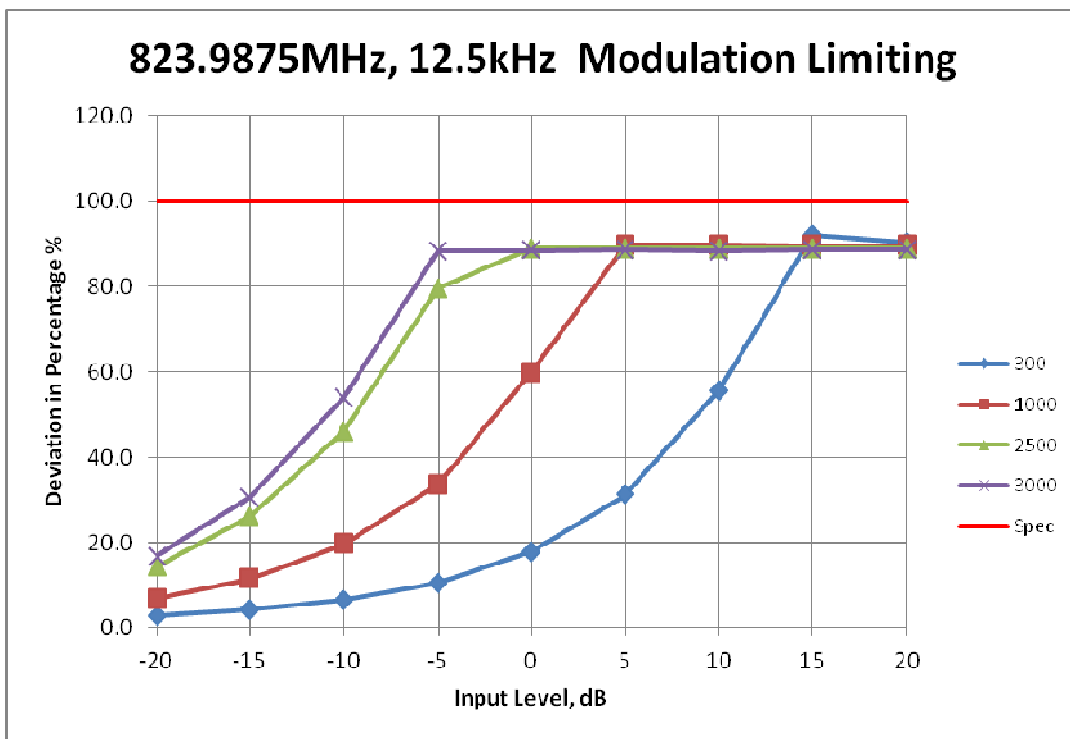
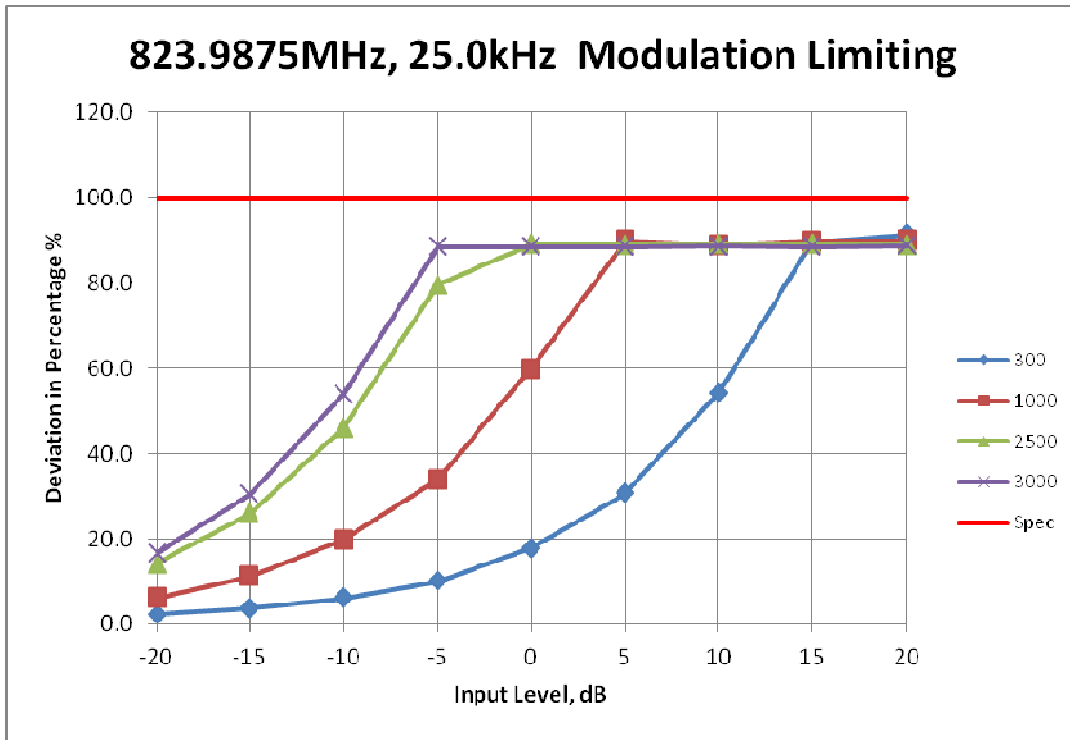

6.5.3. Test Limit

Modulation Limiting shall not exceed 100 percent.

6.6. Occupied Bandwidth

6.6.1. Test Setup (Analog)

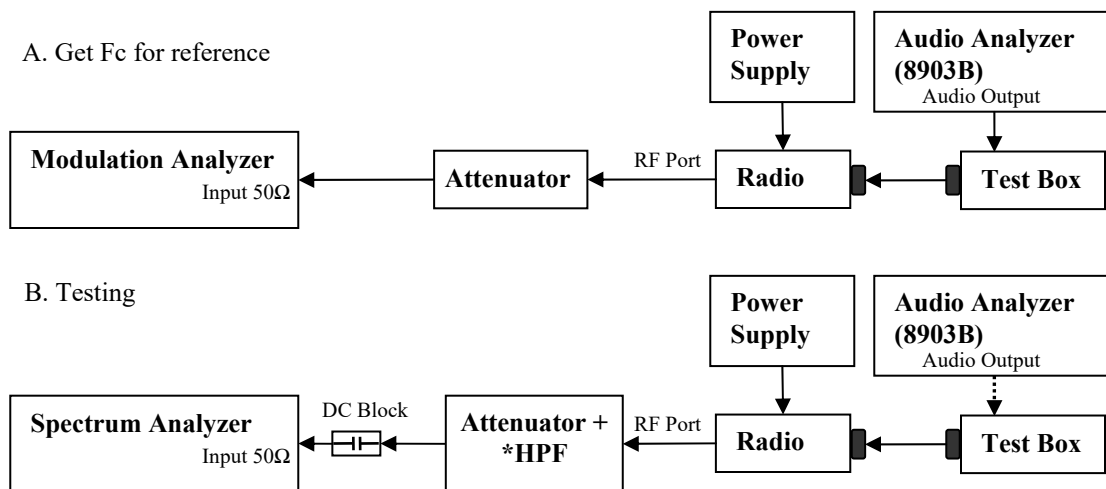

- 1) The DUT transmitter output port was connected to Modulation Analyzer.
- 2) Set the audio bandwidth filter to 15 kHz low pass filter and 50 kHz high pass filter.
- 3) Transmit the radio and set the audio analyzer to 2.5 kHz audio frequency and 50% of the rated deviation. Up the amplitude by 16 dB. Dekey the DUT.
- 4) Path loss for the measurement included.
- 5) Select the Occupied Bandwidth measurement for 99% Emissions Bandwidth Measurement.
- 6) Key in the Fc and Resolution Bandwidth (1 ~ 5 % of emission designator).
- 7) Transmit the DUT and record the occupied Bandwidth frequency.
- 8) Preset the spectrum analyzer for sideband spectrum measurement.
- 9) Set the span and Resolution Bandwidth (according to FCC/ ISED standard).
- 10) Save the screen shot as modulated signal
- 11) Remove the audio tone from audio analyzer to capture unmodulated signal.

* Only HPF added for Mask 80.211 measurement with attenuator.

* 99% Bandwidth measurement is computed by the spectrum analyzer and is consistent with the C63.26 5.4.4 method.

6.6.2. Test Result (Analog)

Standard Audio Modulation (25 kHz Channelization, Analog Voice):
Emission Designator 16K0F3E

In this case, the maximum modulating frequency is 3 kHz with a 5 kHz deviation.

$BW = 2(M+D) = 2*(3 \text{ kHz} + 5 \text{ kHz}) = 16 \text{ kHz} = 16K0$
F3E portion of the designator indicates voice.

Therefore, the entire designator for 25 kHz channelization analog voice is 16K0F3E.

Standard Audio Modulation (12.5 kHz Channelization, Analog Voice):
Emission Designator 11K0F3E

In this case, the maximum modulating frequency is 3.0 kHz with a 2.5 kHz deviation.

$BW = 2(M+D) = 2*(3.0 \text{ kHz} + 2.5 \text{ kHz}) = 11 \text{ kHz} = 11K0$
F3E portion of the designator indicates voice.

Therefore, the entire designator for 12.5 kHz channelization analog voice is 11K0F3E.

Not for FCC review

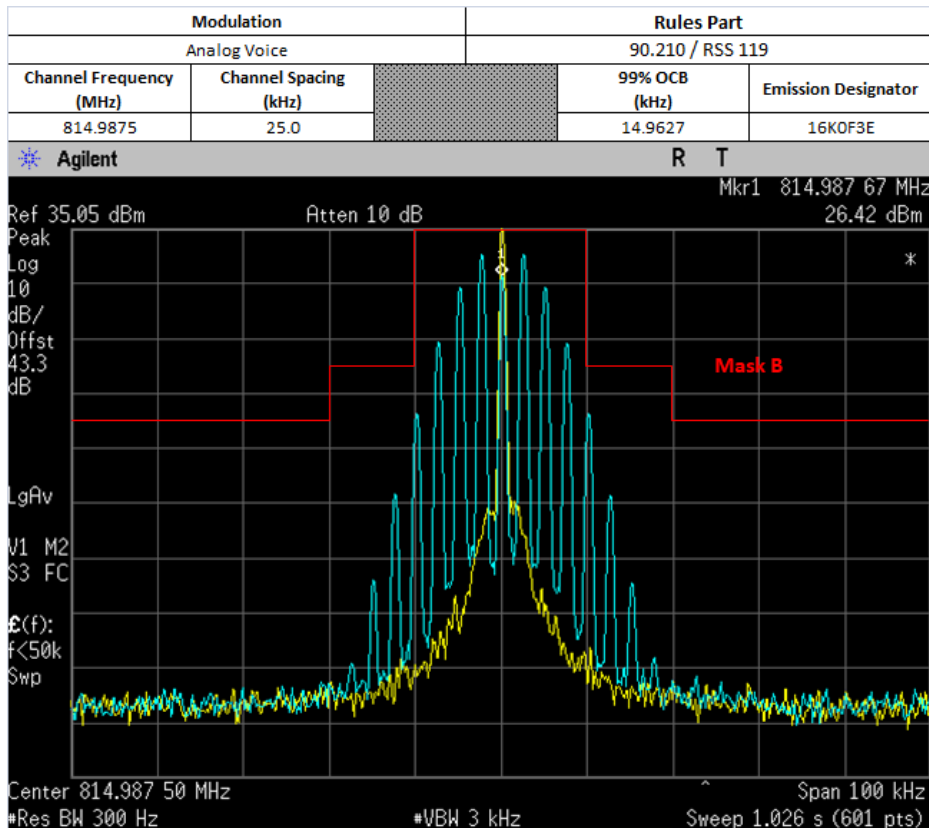
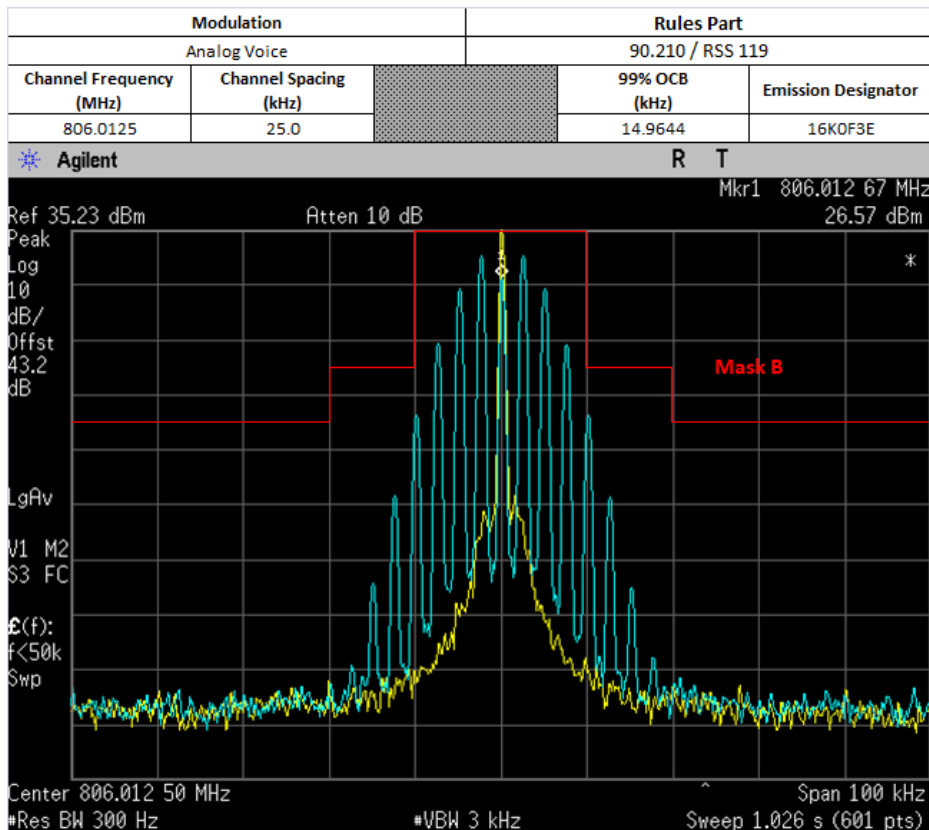

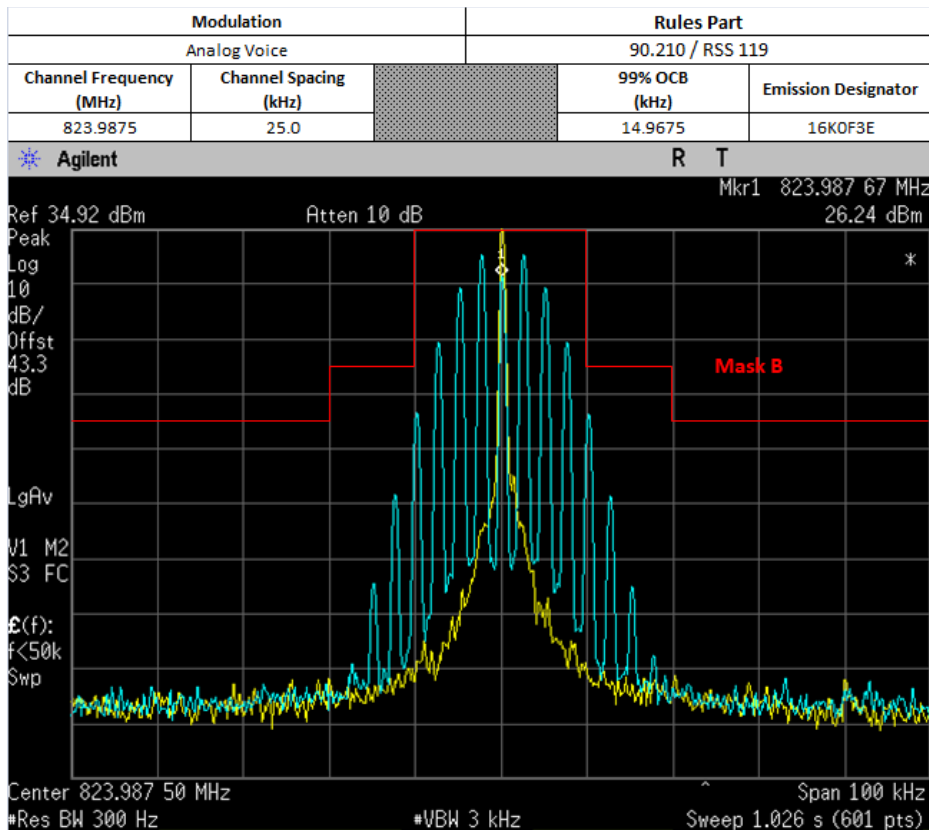

Not for FCC review

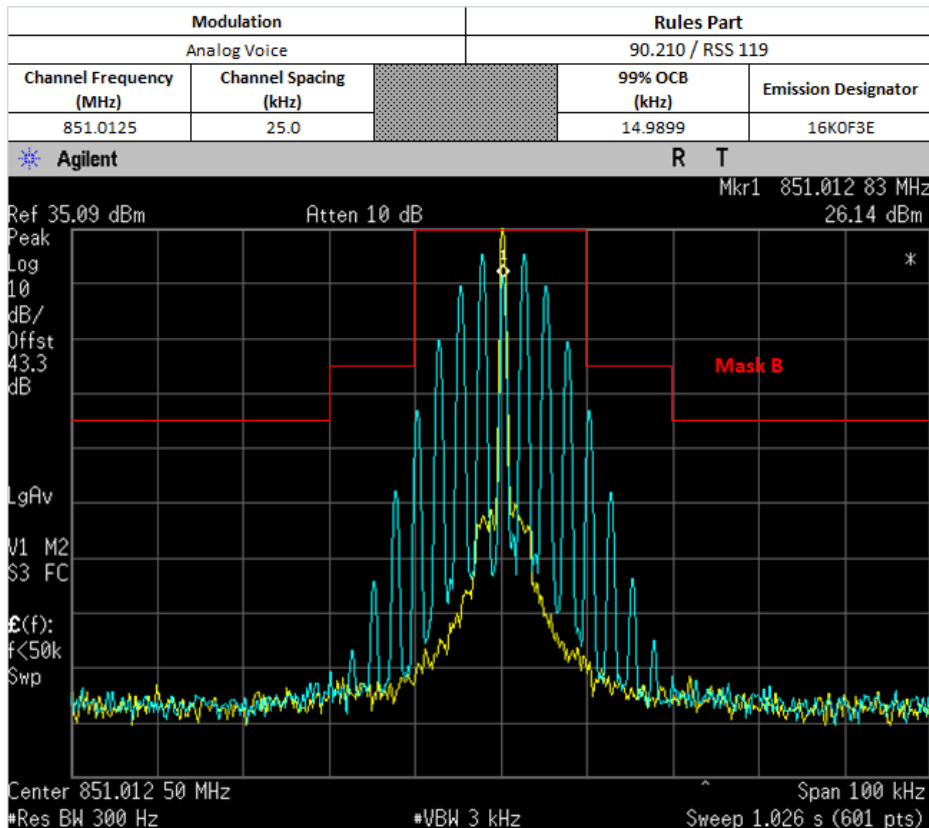

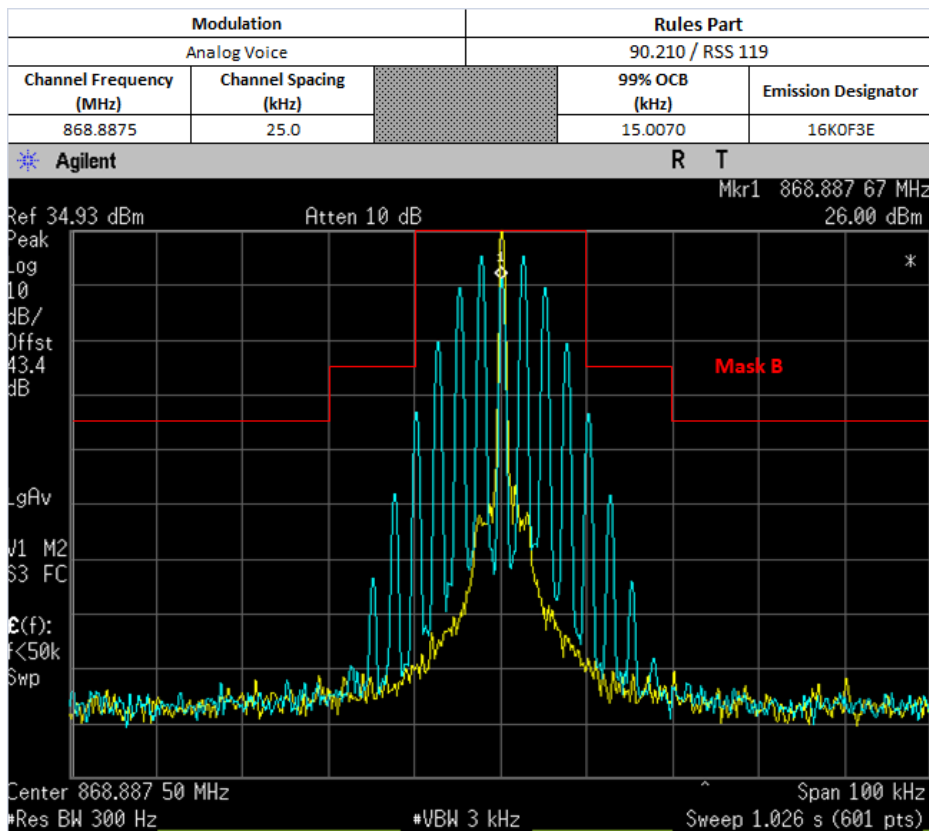
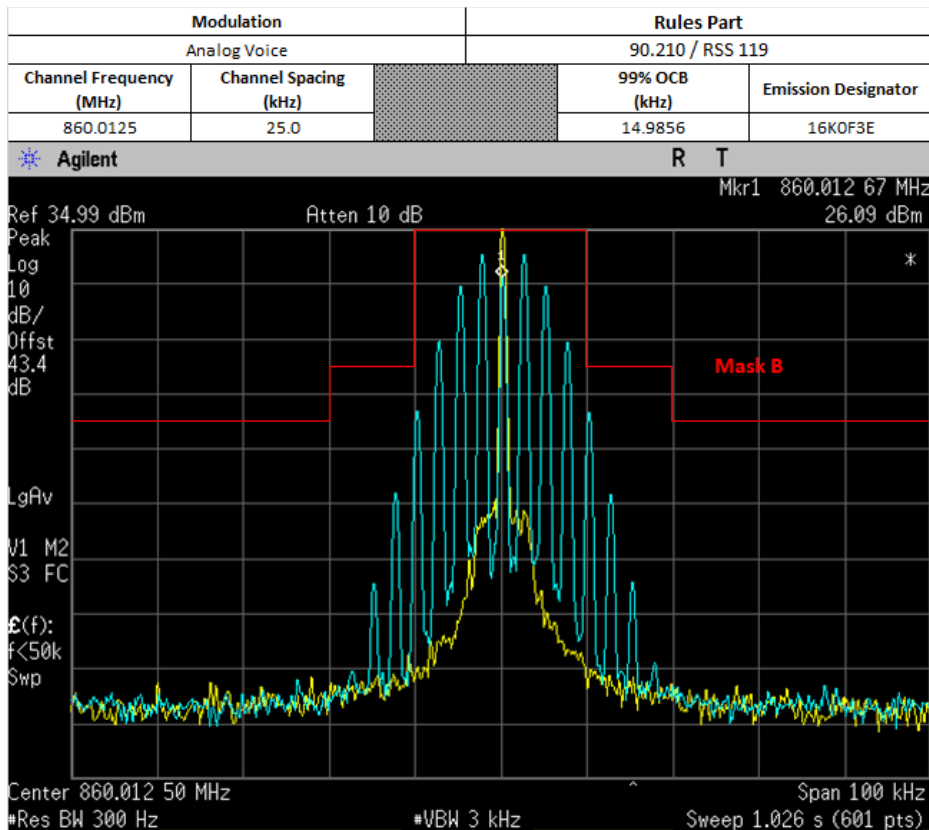

Not for FCC review

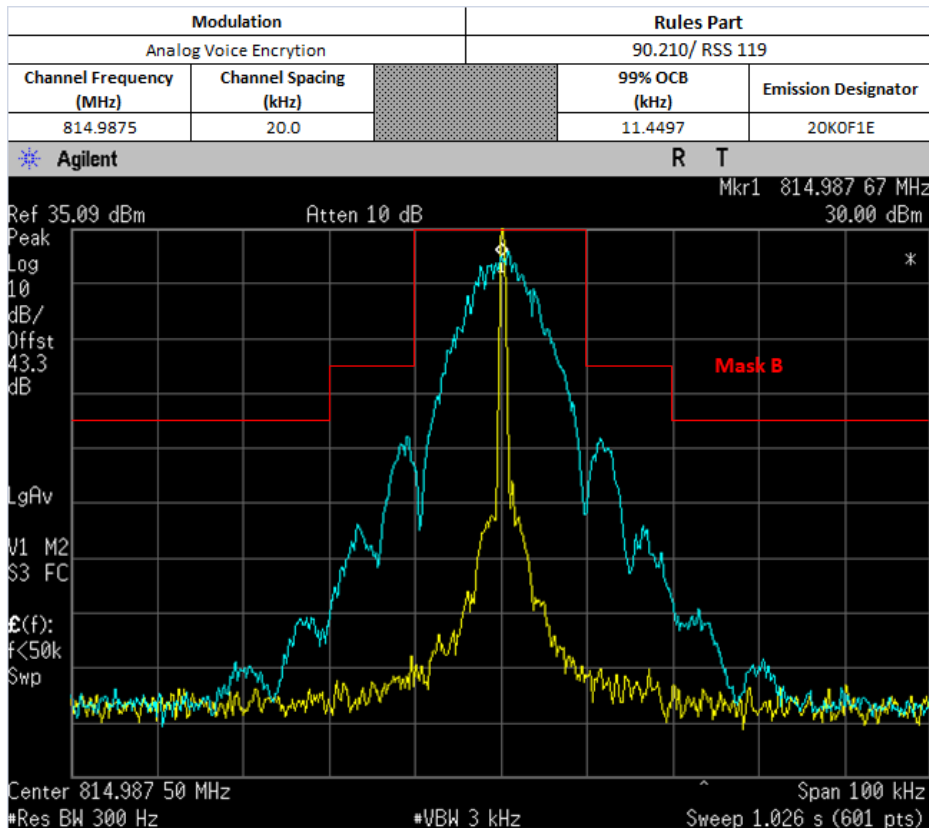
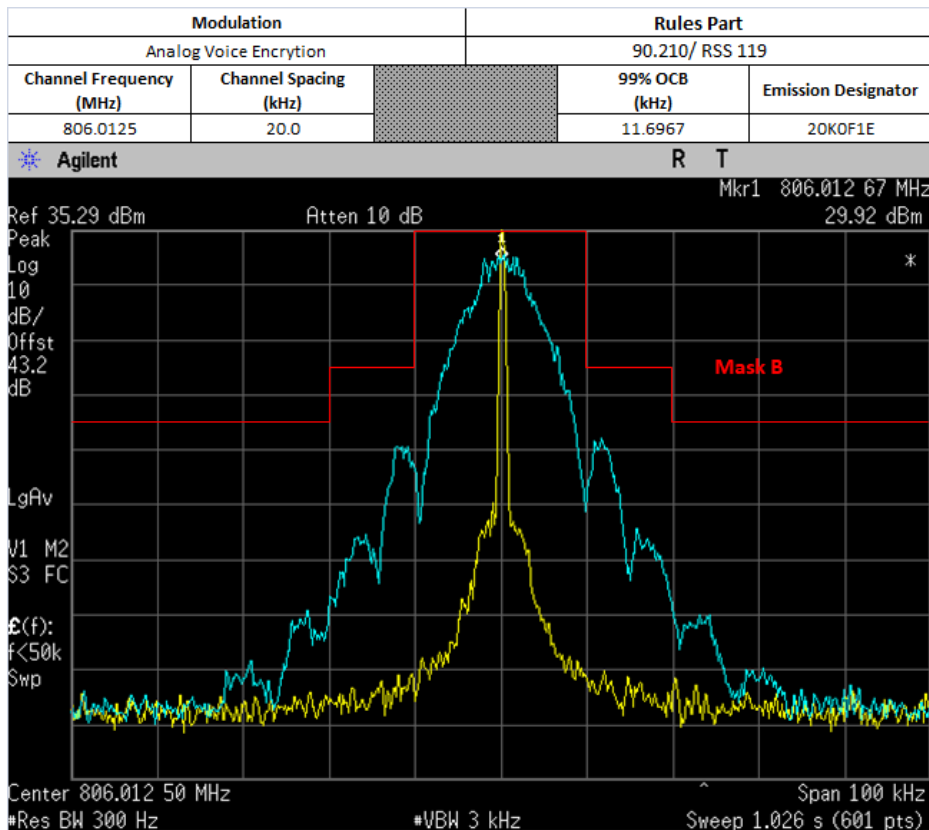

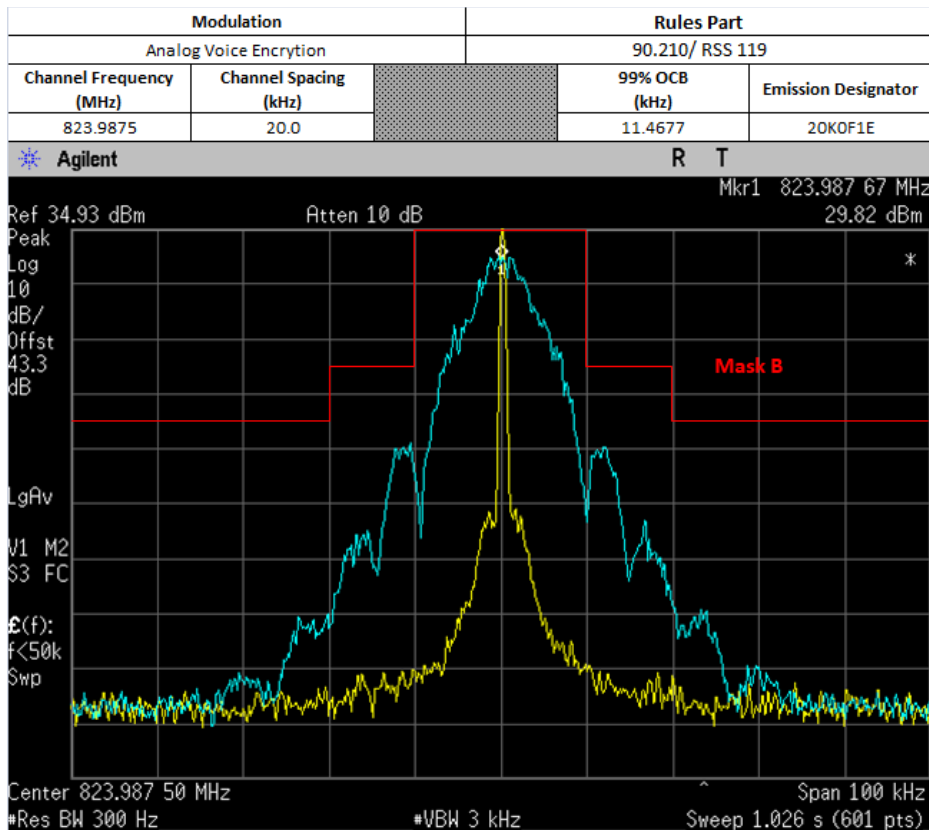

Not for FCC review

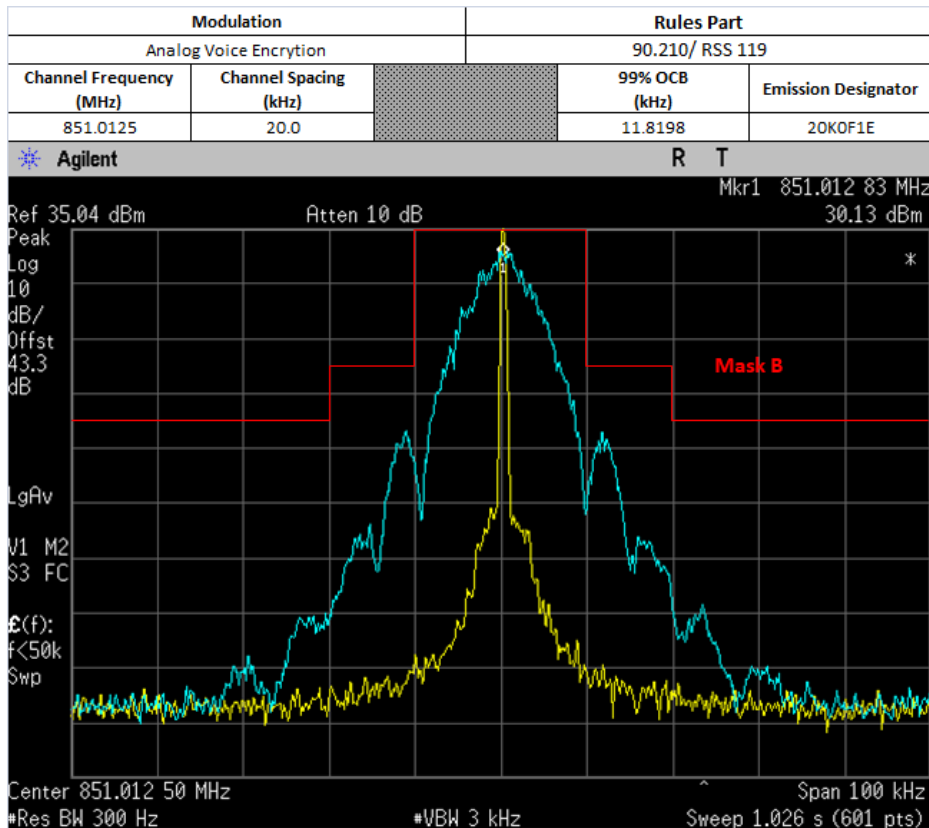

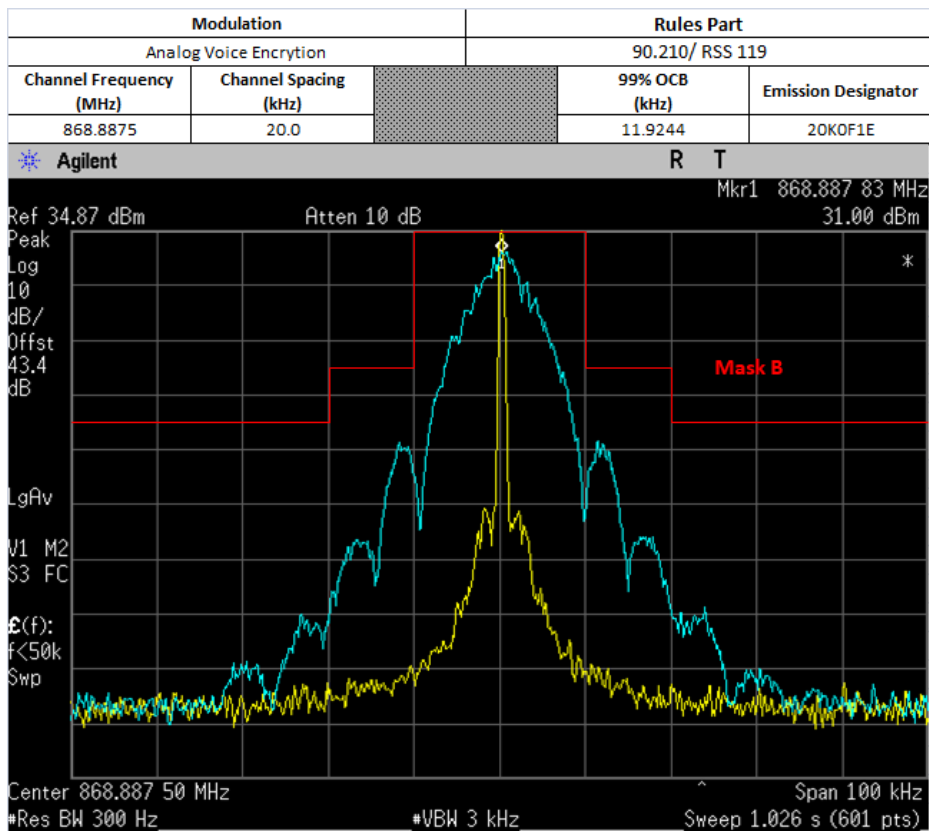
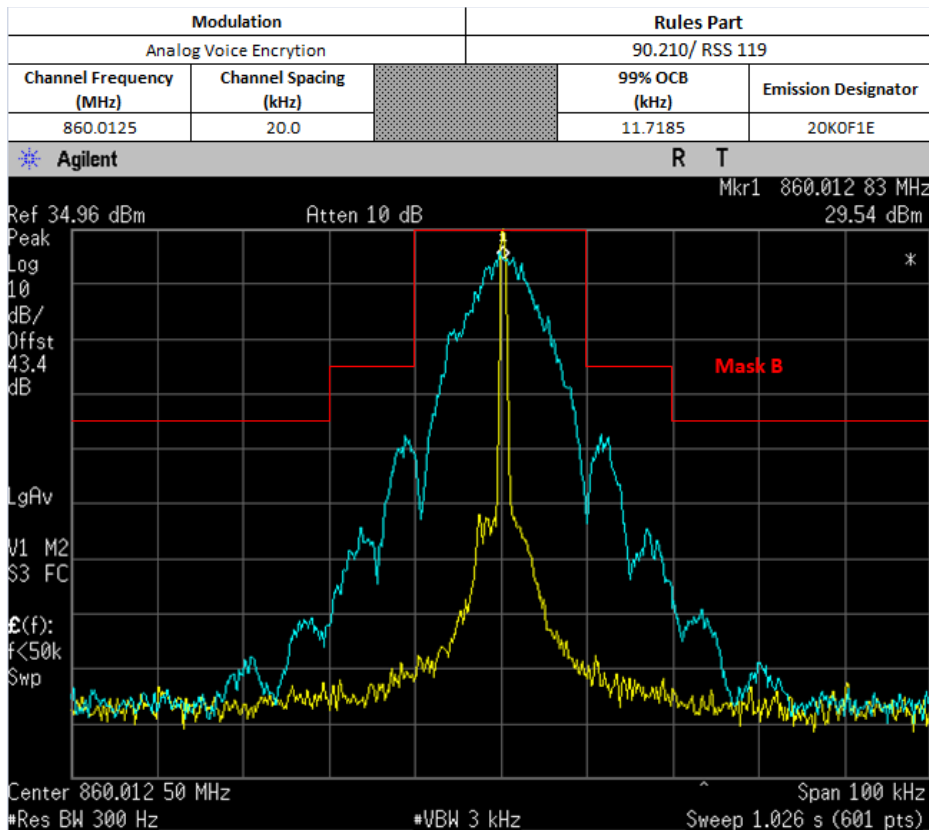

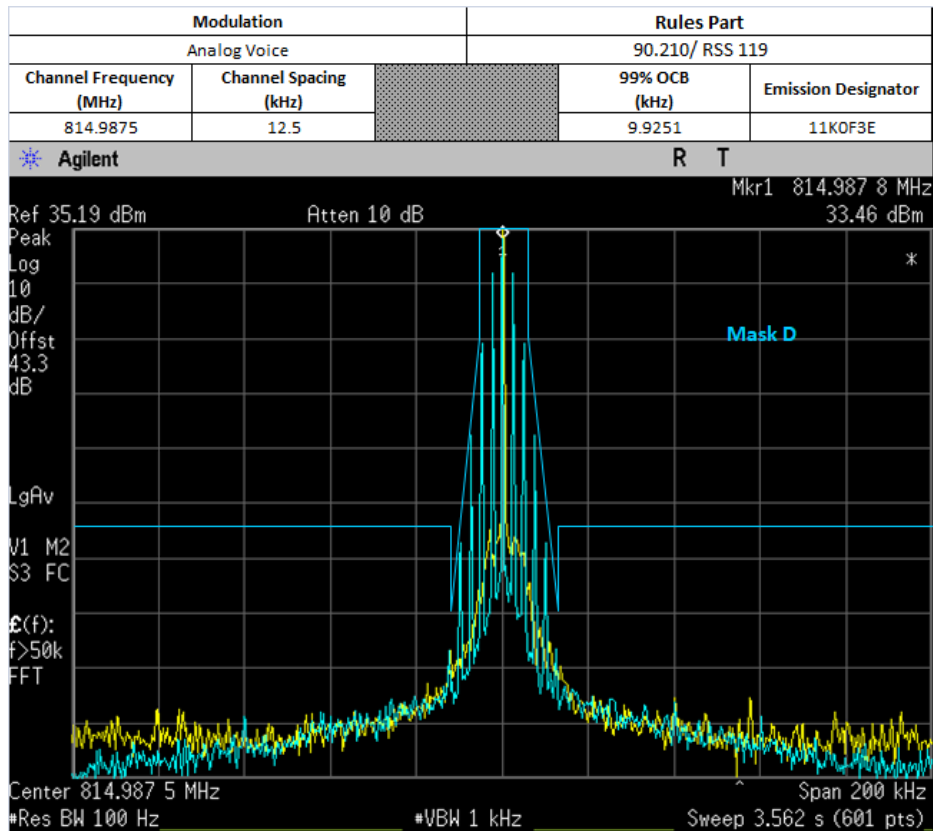
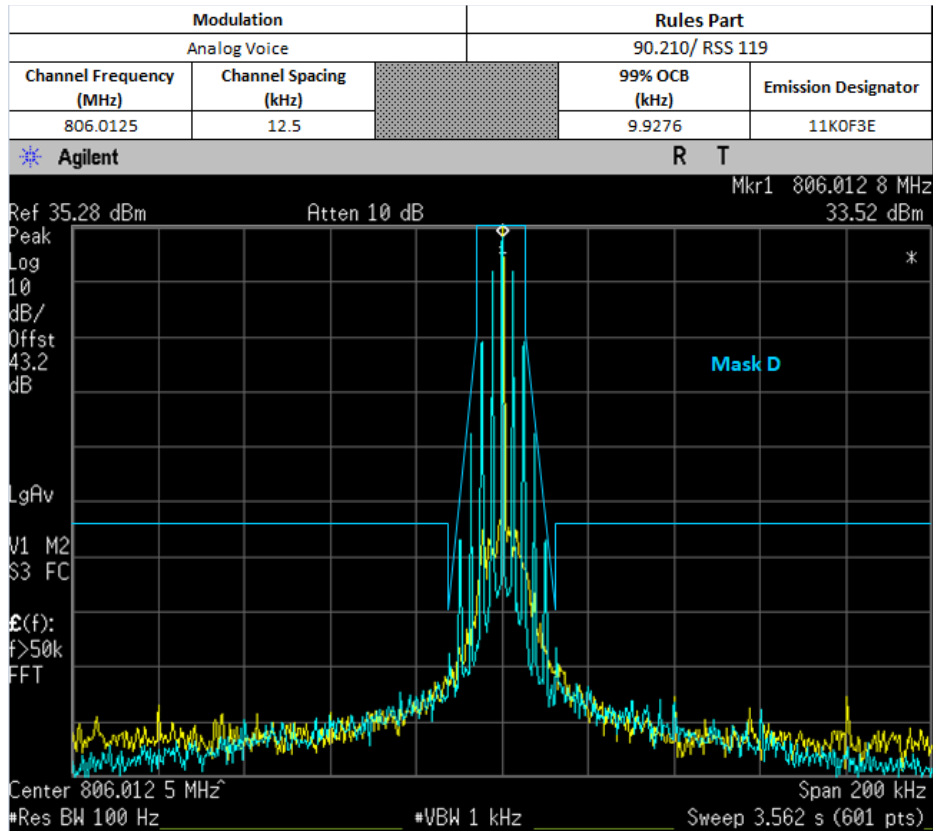

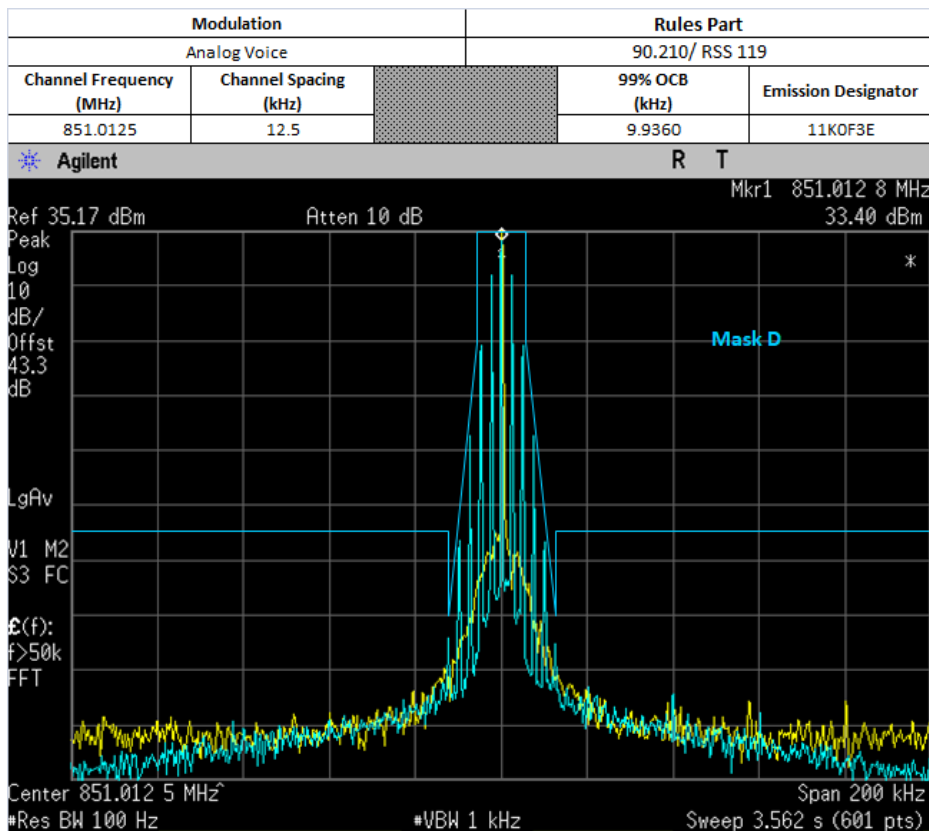
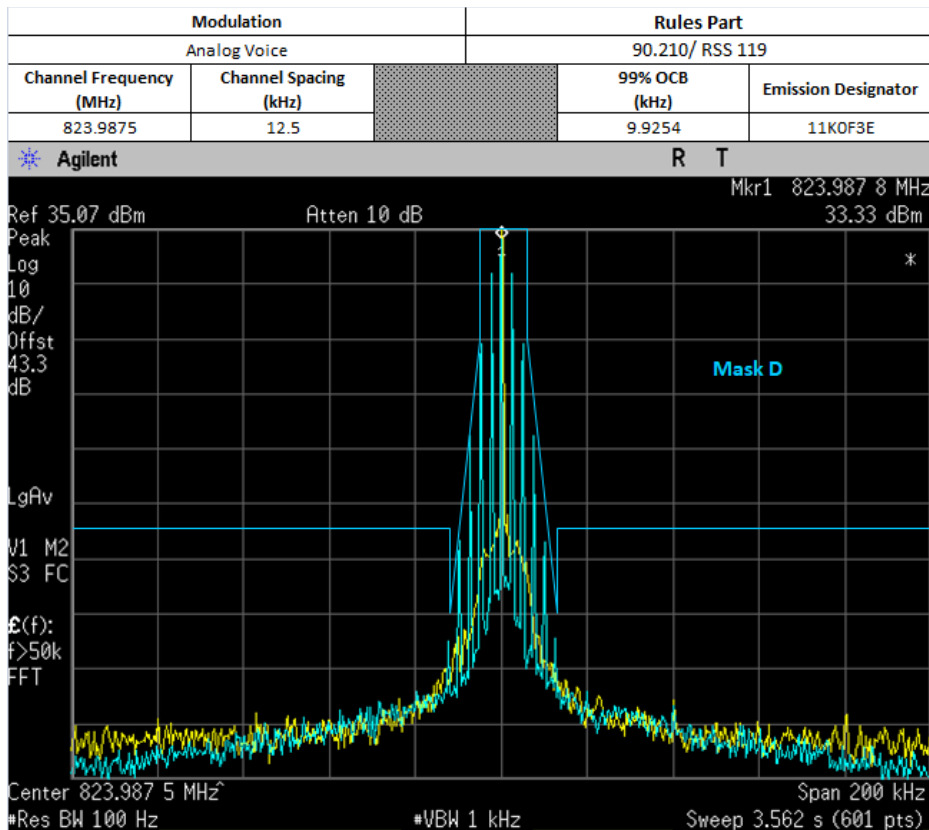

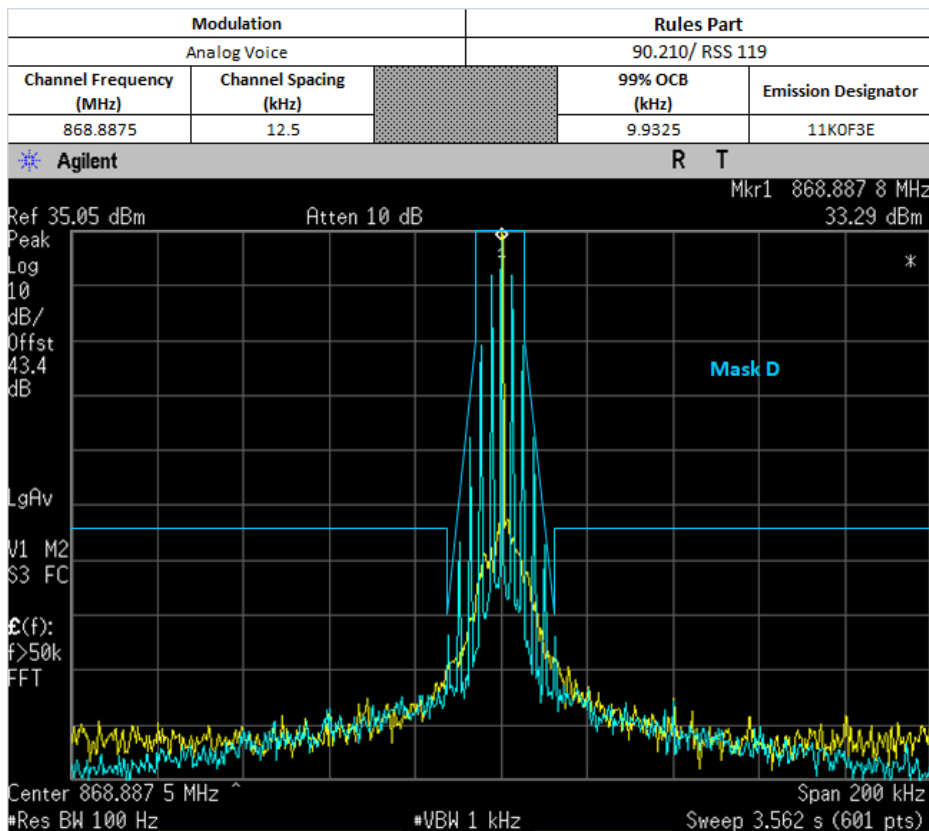
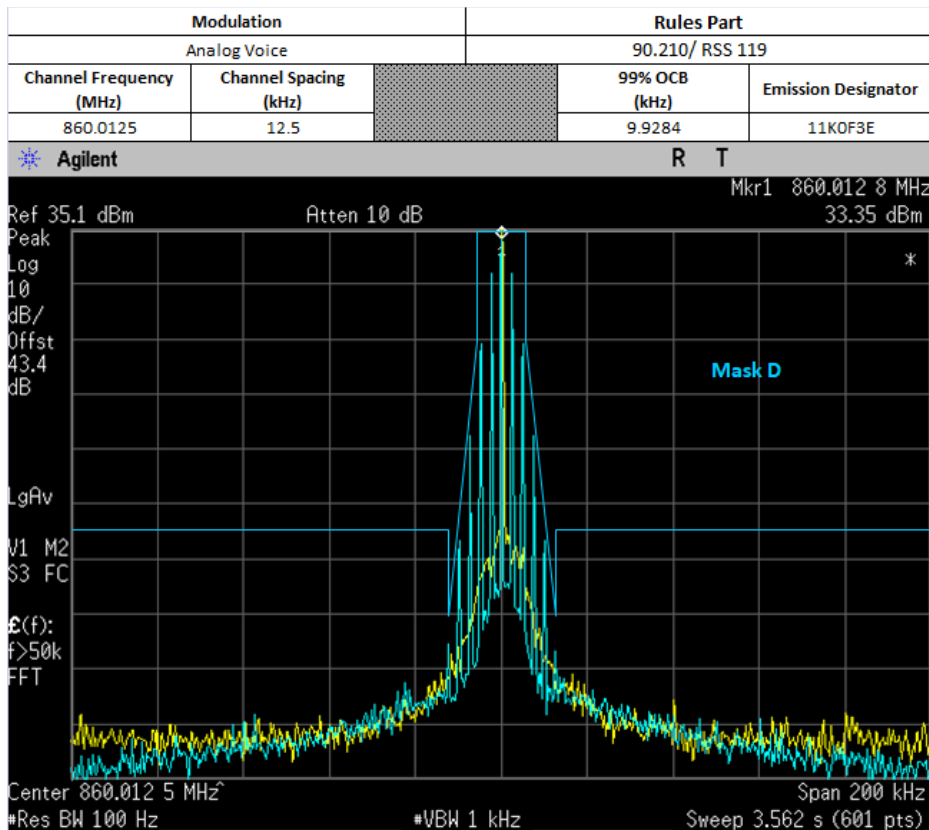

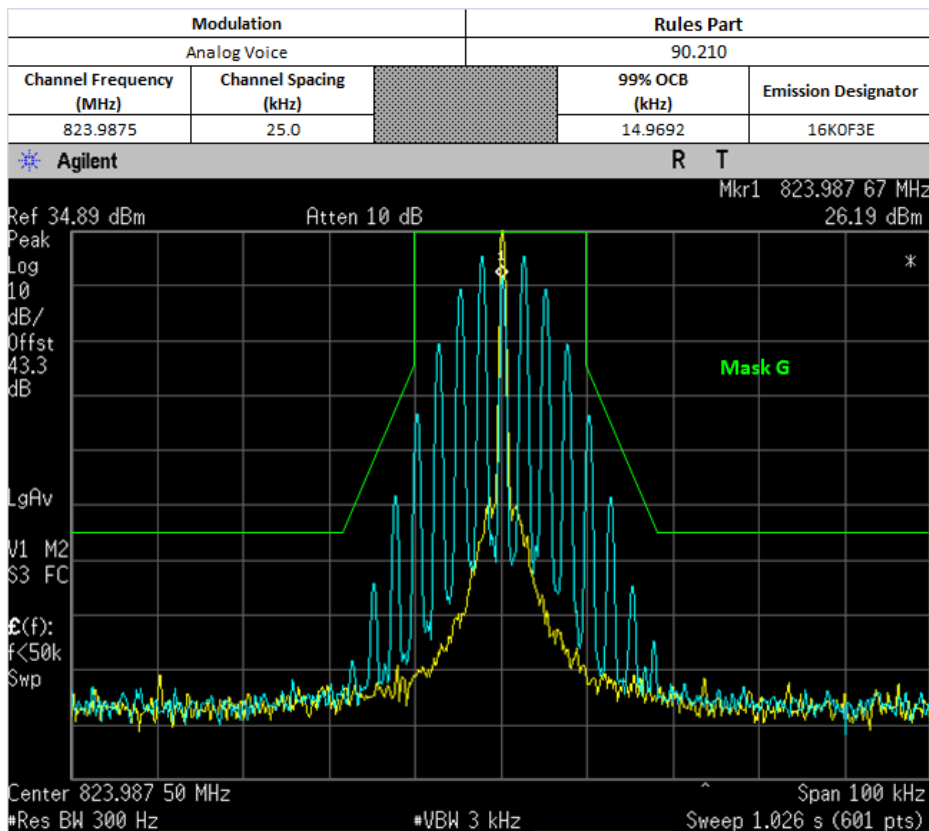
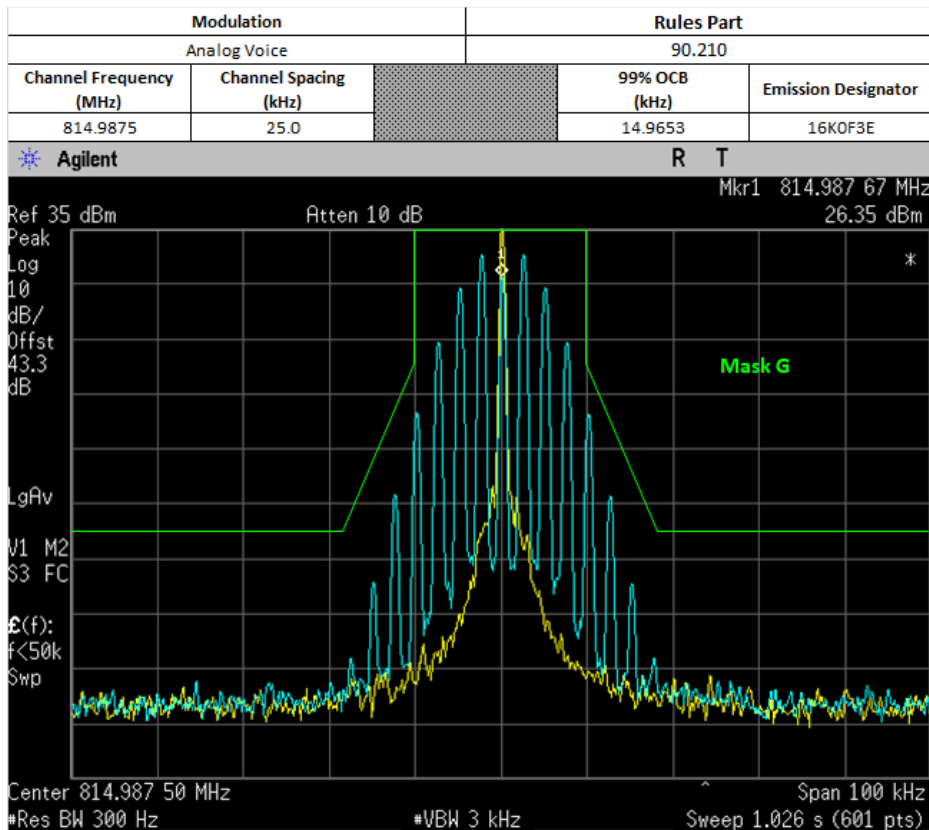

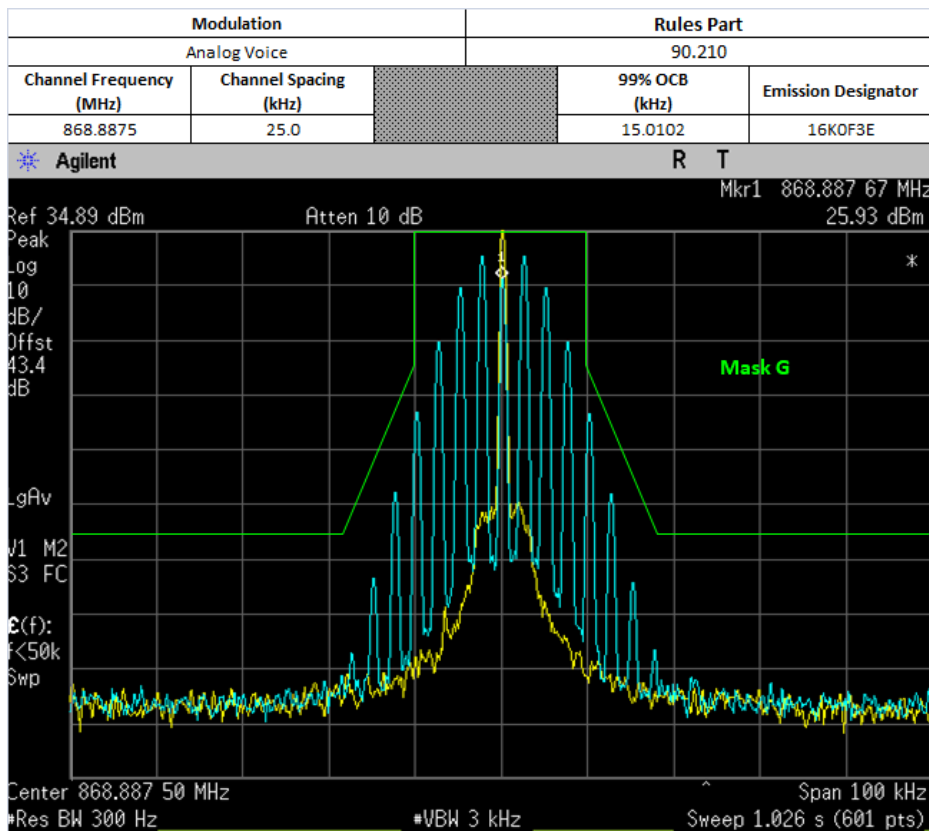
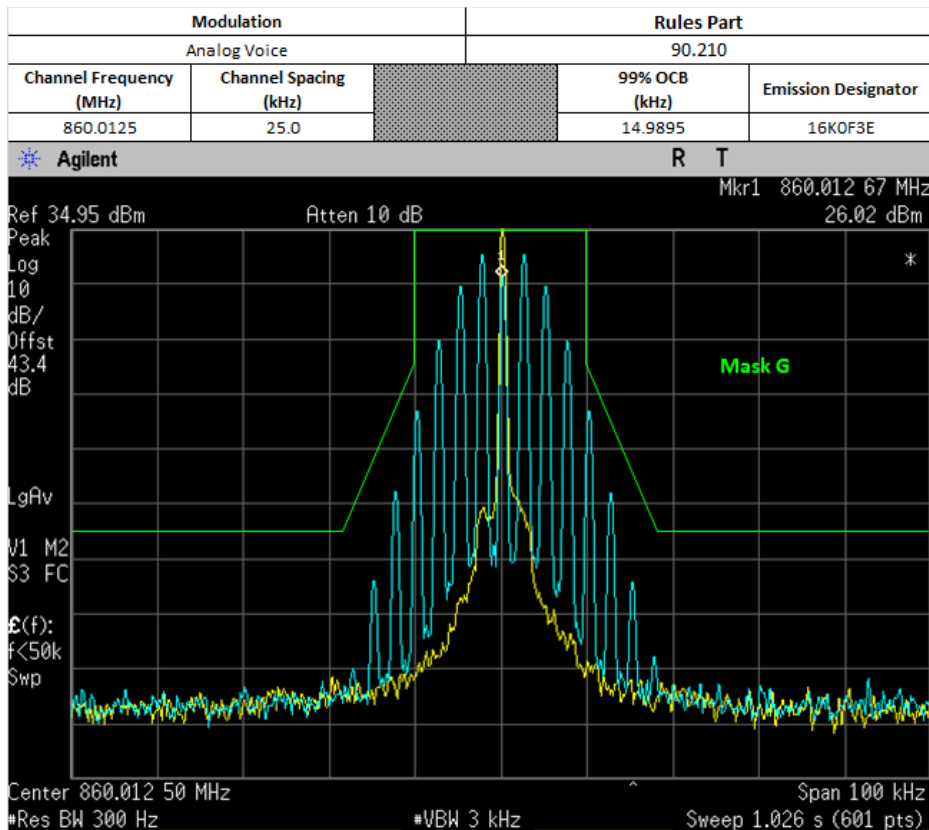

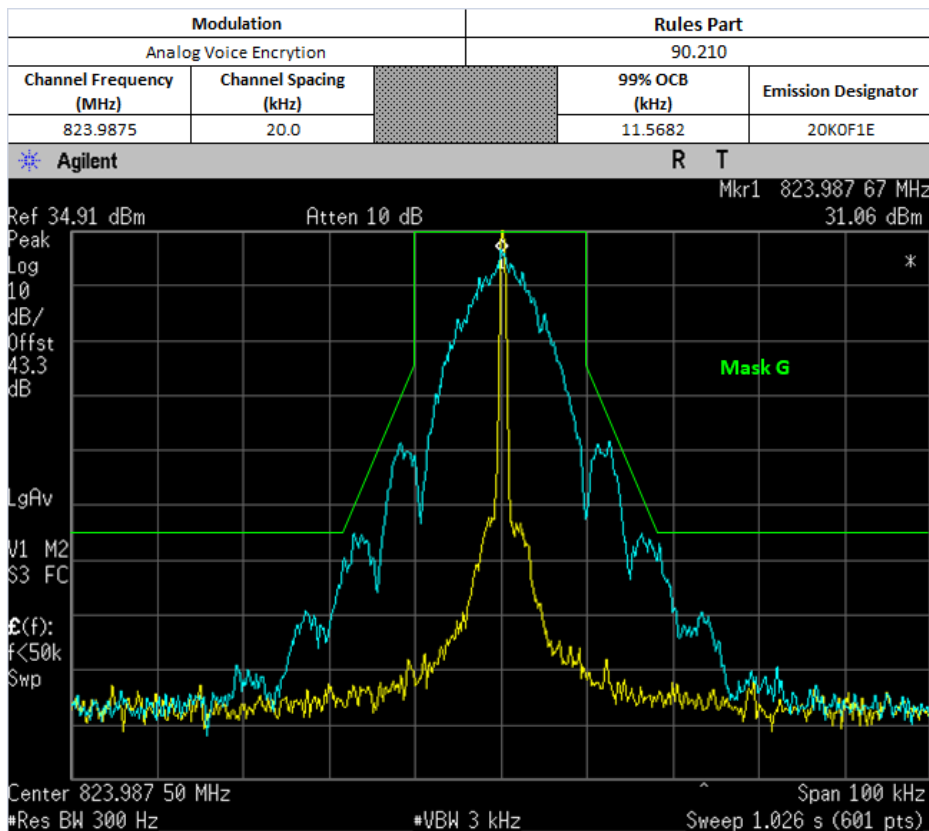
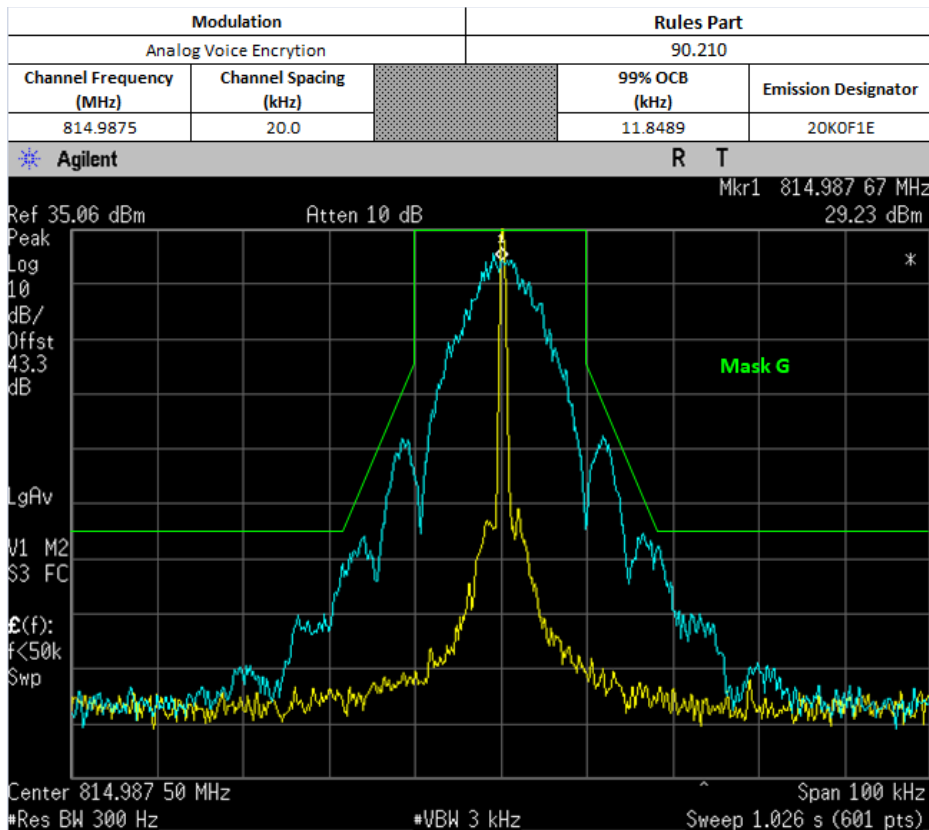

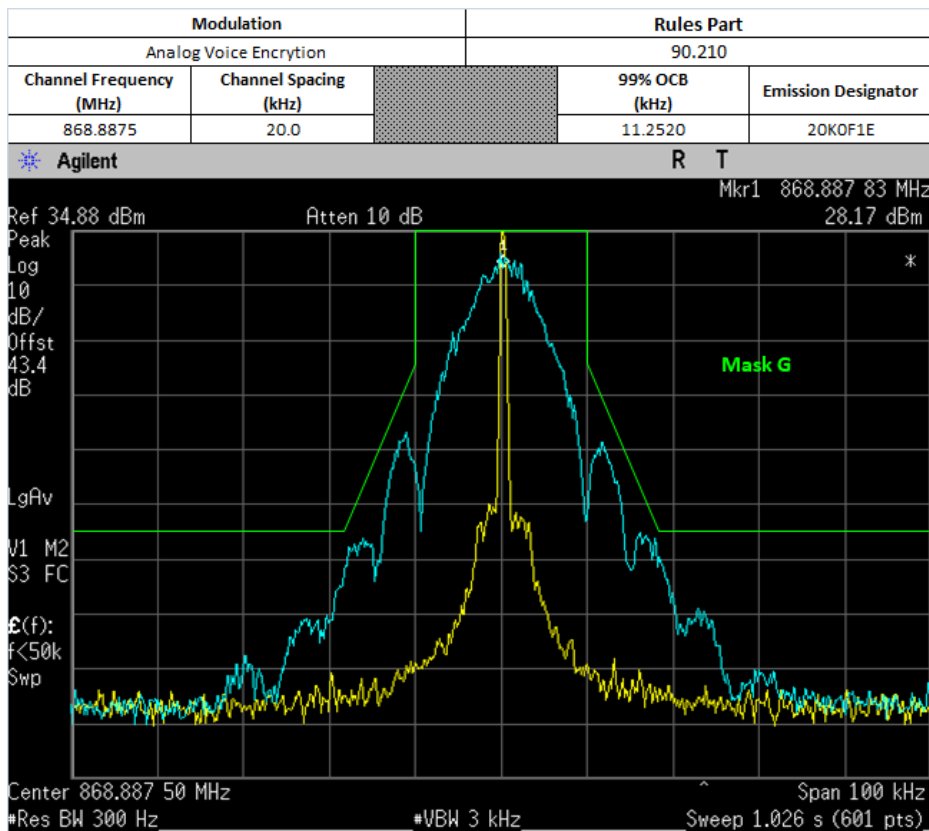
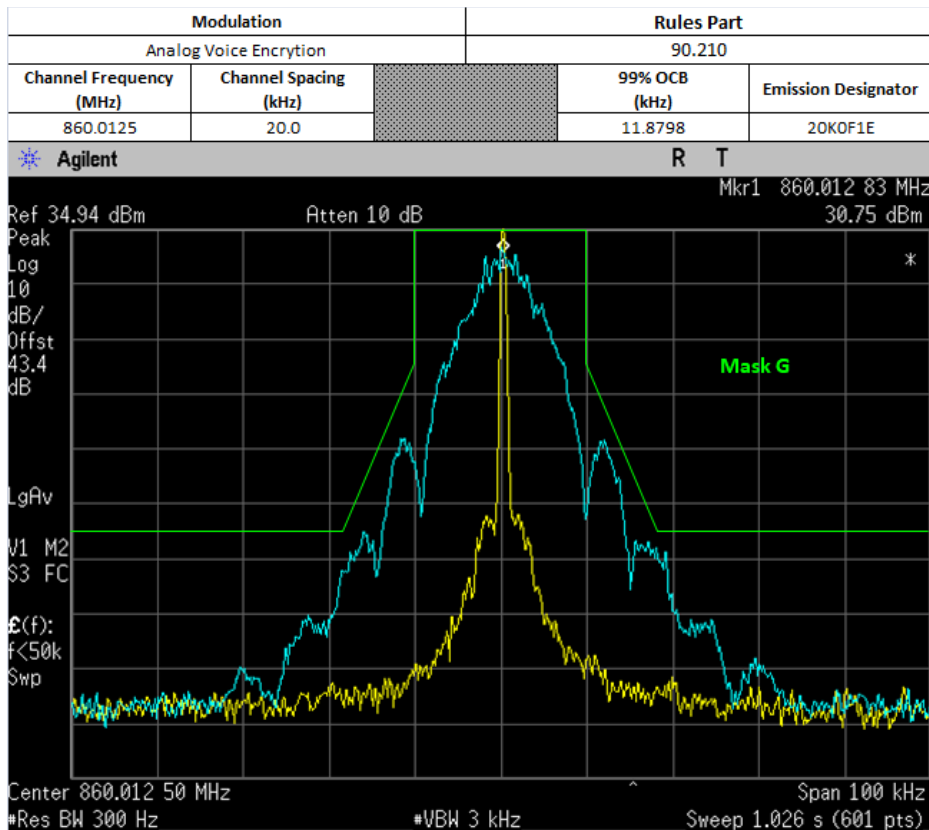

Not for IC review

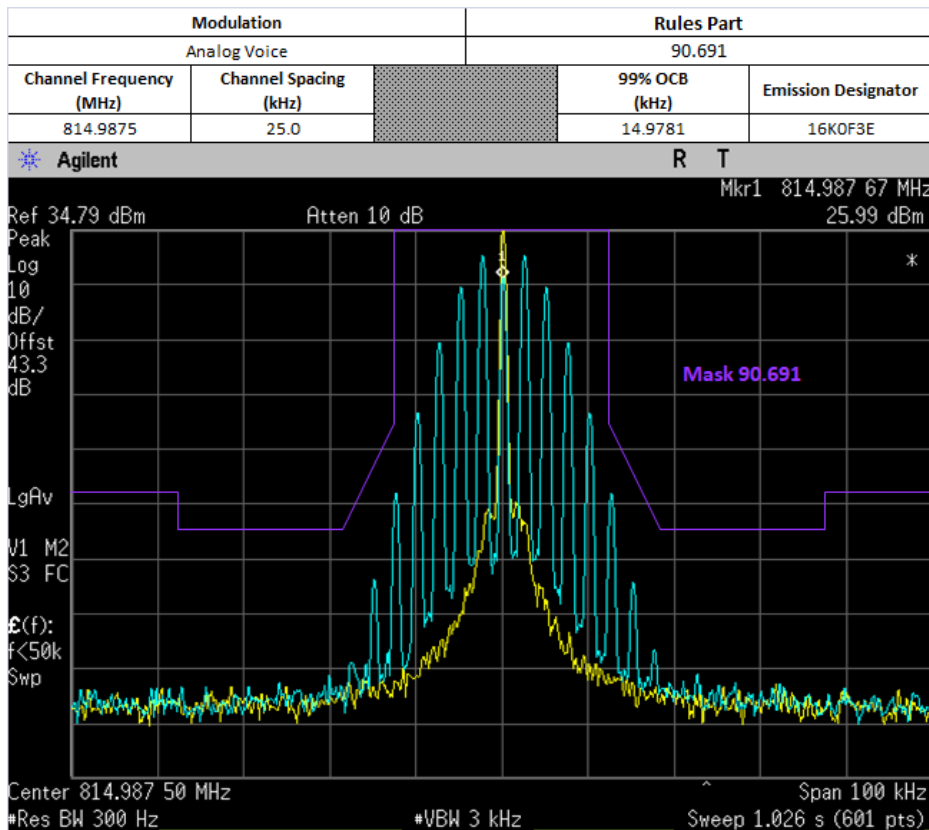

Not for IC review

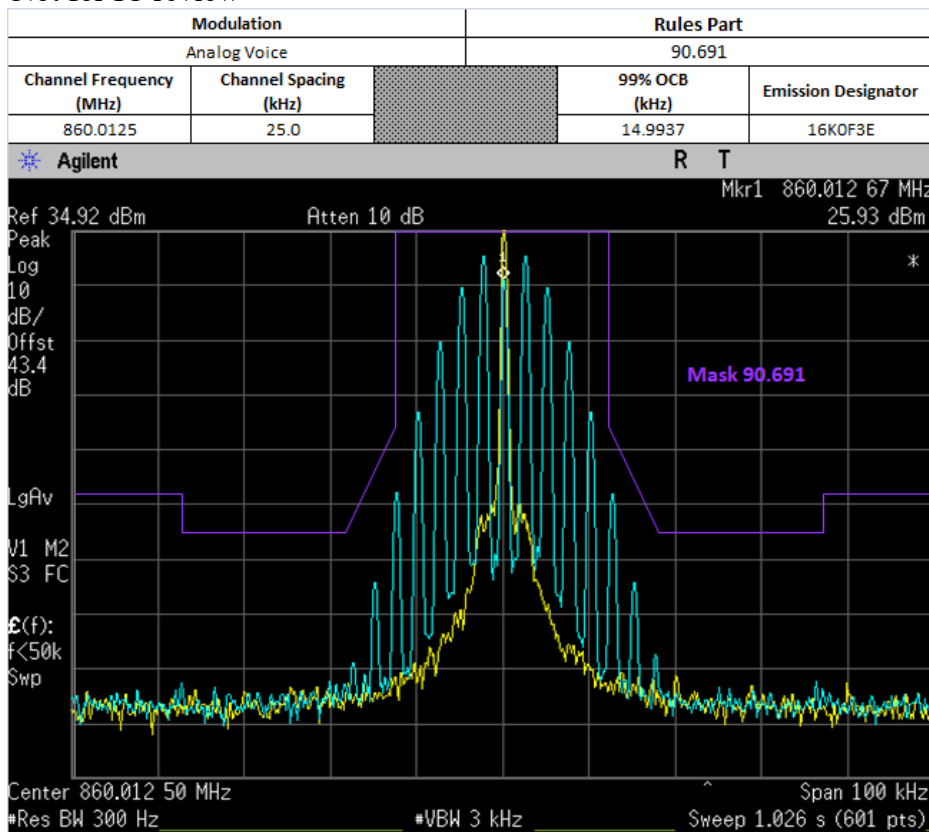

6.6.3. Test Setup (Digital)

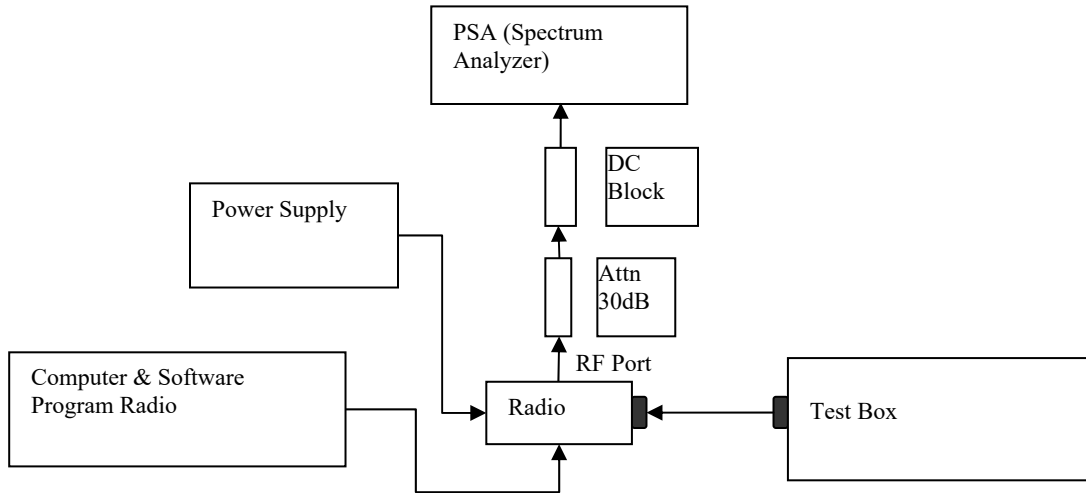

- 1) Program and set radio to operate in desire test frequency and digital mode with modulation. (*4FSK, C4FM or other digital modulation form).
- 2) Path loss for the measurement included.
- 3) Select the Occupied Bandwidth measurement for 99% Emissions Bandwidth Measurement.
- 4) Key in the Fc and Resolution Bandwidth (1 ~ 5 % of emission designator).
- 5) Transmit the DUT and record the occupied Bandwidth frequency.
- 6) Preset the spectrum analyzer for modulation emission spectrum measurement.
- 7) Set the span and Resolution Bandwidth (according to FCC/ ISED standard).
- 8) Capture the screen shot as modulated signal.

* 99% Bandwidth measurement is computed by the spectrum analyzer and is consistent with the C63.26 5.4.4 method.

*Note:

- For Digital Modulation, 12.5 kHz Data F1D & FXD would be the same. Therefore only measurements with F1D modulation shown below.
- For Digital Modulation, 12.5 kHz Data F1E & FXE would be the same. Therefore only measurements with F1E modulation shown below.

6.6.4. Test Result (Digital)

Digital (12.5 kHz Channelization, Digital Voice/Data/Voice+Data):
Emission Designator 8K10F1E/D/W

The 99% energy rule (title 47CFR 2.989) was used for digital mode and is more accurate than Carson's rule. It basically states that 99% of the modulation energy falls within X kHz, in this case, 8.10 kHz. Measurements were performed in accordance with TIA/EIA TSB102.CAAB Section 2.2.5.2. The emission mask was obtained from 47CFR 90.210(d).

F1E/D/W portion of the designator indicates digital voice/data/voice+data.

Therefore, the entire designator for 12.5 kHz channelization digital voice is 8K10F1E/D/W.

