

TEST REPORT

CERTIFICATE OF CONFORMITY

Standard: 47 CFR FCC Part 15, Subpart C (Section 15.225)

Report No.: RFBBQZ-WTW-P24040390 R1

FCC ID: AZ489FT7149

Product: APX N70

Brand: Motorola Solutions

Model No.: H35KET9PW8AN

Received Date: 2024/4/18

Test Date: 2024/4/24 ~ 2024/4/26

Issued Date: 2024/8/1

Applicant: Motorola Solutions, Inc.

Address: Plot 2A, Medan Bayan Lepas, Mukim 12 SWD, 11900 Bayan Lepas,
Penang, Malaysia

Issued By: Bureau Veritas Consumer Products Services (H.K.) Ltd., Taoyuan Branch
Lin Kou Laboratories

Lab Address: No. 47-2, 14th Ling, Chia Pau Vil., Lin Kou Dist., New Taipei City, Taiwan

Test Location: No. 19, Hwa Ya 2nd Rd., Wen Hwa Vil., Kewi Shan Dist., Taoyuan City 33383, Taiwan

**FCC Registration /
Designation Number:** 788550 / TW0003

Approved by: Jeremy Lin , **Date:** 2024/8/1
Jeremy Lin / Project Engineer

This test report consists of 42 pages in total. It may be duplicated completely for legal use with the approval of the applicant. It should not be reproduced except in full, without the written approval of our laboratory. The test results in the report only apply to the tested sample. The test results in this report are traceable to the national or international standards.

Prepared by : Pettie Chen / Senior Specialist



This report is governed by, and incorporates by reference, the Conditions of Testing as posted at the date of issuance of this report at <http://www.bureauveritas.com/home/about-us/our-business/cps/about-us/terms-conditions/> and is intended for your exclusive use. Any copying or replication of this report to or for any other person or entity, or use of our name or trademark, is permitted only with our prior written permission. This report sets forth our findings solely with respect to the test samples identified herein. The results set forth in this report are not indicative or representative of the quality or characteristics of the lot from which a test sample was taken or any similar or identical product unless specifically and expressly noted. Our report includes all of the tests requested by you and the results thereof based upon the information that you provided to us. Measurement uncertainty is only provided upon request for accredited tests. Statements of conformity are based on simple acceptance criteria without taking measurement uncertainty into account, unless otherwise requested in writing. You have 60 days from date of issuance of this report to notify us of any material error or omission caused by our negligence or if you require measurement uncertainty; provided, however, that such notice shall be in writing and shall specifically address the issue you wish to raise. A failure to raise such issue within the prescribed time shall constitute your unqualified acceptance of the completeness of this report, the tests conducted and the correctness of the report contents.

Table of Contents

Release Control Record	3
1 Certificate	4
2 Summary of Test Results	5
2.1 Measurement Uncertainty	5
2.2 Supplementary Information	5
3 General Information	6
3.1 General Description	6
3.2 Antenna Description of EUT	7
3.3 Channel List	7
3.4 Test Mode Applicability and Tested Channel Detail	8
3.5 Test Program Used and Operation Descriptions	9
3.6 Connection Diagram of EUT and Peripheral Devices	9
3.7 Configuration of Peripheral Devices and Cable Connections	9
4 Test Instruments	10
4.1 AC Power Conducted Emissions	10
4.2 Radiated Emissions below 30 MHz	11
4.3 Radiated Emissions above 30 MHz	12
4.4 Frequency Stability	12
4.5 20 dB Bandwidth	13
5 Limits of Test Items	14
5.1 AC Power Conducted Emissions	14
5.2 Radiated Emissions below 30 MHz	14
5.3 Radiated Emissions above 30 MHz	14
5.4 Frequency Stability	15
5.5 20 dB Bandwidth	15
6 Test Arrangements	16
6.1 AC Power Conducted Emissions	16
6.1.1 Test Setup	16
6.1.2 Test Procedure	16
6.2 Radiated Emissions below 30 MHz	17
6.2.1 Test Setup	17
6.2.2 Test Procedure	18
6.3 Radiated Emissions above 30 MHz	18
6.3.1 Test Setup	18
6.3.2 Test Procedure	19
6.4 Frequency Stability	19
6.4.1 Test Setup	19
6.4.2 Test Procedure	19
6.5 20 dB Bandwidth	20
6.5.1 Test Setup	20
6.5.2 Test Procedure	20
7 Test Results of Test Item	21
7.1 AC Power Conducted Emissions	21
7.2 Radiated Emissions below 30 MHz	23
7.3 Radiated Emissions above 30 MHz	35
7.4 Frequency Stability	39
7.5 20 dB Bandwidth	40
8 Pictures of Test Arrangements	41
9 Information of the Testing Laboratories	42

Release Control Record

Issue No.	Description	Date Issued
RFBBQZ-WTW-P24040390	Original release.	2024/5/28
RFBBQZ-WTW-P24040390 R1	Revise applicant	2024/8/1

1 Certificate

Product: APX N70

Brand: Motorola Solutions

Test Model: H35KET9PW8AN

Sample Status: Engineering sample

Applicant: Motorola Solutions, Inc.

Test Date: 2024/4/24 ~ 2024/4/26

Standard: 47 CFR FCC Part 15, Subpart C (Section 15.225)
47 CFR FCC Part 15, Subpart C (Section 15.215)

Measurement procedure: ANSI C63.10-2013

The above equipment has been tested by **Bureau Veritas Consumer Products Services (H.K.) Ltd., Taoyuan Branch**, and found compliance with the requirement of the above standards. The test record, data evaluation & Equipment Under Test (EUT) configurations represented herein are true and accurate accounts of the measurements of the sample's RF characteristics under the conditions specified in this report.

2 Summary of Test Results

47 CFR FCC Part 15, Subpart C (Section 15.225)			
Standard / Clause	Test Item	Result	Remark
15.207	AC Power Conducted Emissions	Pass	Minimum passing margin is -11.99 dB at 13.56000 MHz
15.225 (a)	The field strength of any emissions within the band 13.553-13.567 MHz	Pass	Meet the requirement of limit.
15.225 (b)	The field strength of any emissions within the bands 13.410-13.553 MHz and 13.567-13.710 MHz	Pass	Meet the requirement of limit.
15.225 (c)	The field strength of any emissions within the bands 13.110-13.410 MHz and 13.710-14.010 MHz	Pass	Meet the requirement of limit.
15.225 (d)	The field strength of any emissions appearing outside of the 13.110-14.010 MHz band below 30MHz	Pass	Meet the requirement of limit.
15.225 (d)	The field strength of any emissions appearing outside of the 13.110-14.010 MHz band above 30MHz	Pass	Minimum passing margin is -5.6 dB at 53.28 MHz
15.225 (e)	Frequency Stability	Pass	Meet the requirement of limit.
15.215 (c)	20 dB Bandwidth	Pass	Meet the requirement of limit.

Note: Determining compliance based on the results of the compliance measurement, not taking into account measurement instrumentation uncertainty.

2.1 Measurement Uncertainty

Where relevant, the following measurement uncertainty levels have been estimated for tests performed on the EUT as specified in CISPR 16-4-2:

Measurement	Specification	Expanded Uncertainty (k=2) (±)
Conducted Emissions from Power Ports	9 kHz ~ 30 MHz	2.88 dB
Radiated Emissions up to 1 GHz	9 kHz ~ 30 MHz	2.44 dB
	30 MHz ~ 1 GHz	2.95 dB
Frequency Stability	-	0.176 ppm

The other instruments specified are routine verified to remain within the calibrated levels, no measurement uncertainty is required to be calculated.

2.2 Supplementary Information

There is not any deviation from the test standards for the test method, and no modifications required for compliance.

3 General Information

3.1 General Description

Product	APX N70
Brand	Motorola Solutions
Test Model	H35KET9PW8AN
Status of EUT	Engineering sample
Power Supply Rating	7.5Vdc from battery 14.5Vdc from adapter
Modulation Type	ASK
NFC Technology Type	NFC-A (ISO/IEC 14443 Type A) NFC-B (ISO/IEC 14443 Type B) NFC-F (ISO/IEC 18092 or FeliCa) NFC-V (ISO/IEC 15693)
Data Rate	Type A: 106 kbit/s Type B: 106 kbit/s Type F: 212 kbit/s, 424 kbit/s Type V: 26.48 kbit/s
Operating Frequency	13.56 MHz
Number of Channel	1
Field Strength of Fundamental	18.60 dBuV/m(30m)

Note:

1. The EUT uses following accessories.

Battery Pack		
Brand	Model	Specification
Motorola	PMNN4816A	Power Rating : 7.5V Standard 3200mAh
AC Adapter		
Brand	Model	Specification
Motorola	ML36-4145250-A1	Part Number: PS000040A02 AC Input : 100-240 Vac, ~60 Hz, 1 A DC Output : 14.5 Vdc, 2.5 A DC Output Cable : 1.5 m DC Cable with 1 core attached Description : POWER SUPPLY ADAPTOR,POWER- WALL CUBE,AC,DC,110VAC FIXED BLADE US 14.5V/2.5A L6 BARREL NDAA
Single Unit Charger (SUC)		
Brand	Model	Description
Motorola	PMPN4590A	CHARGER,CHGR DESKTOP SINGLE UNIT IMPRES 2 EXT PS BASE ONLY

2. The above EUT information is declared by manufacturer and for more detailed features description, please refer to the manufacturer's specifications or User's Manual.

3.2 Antenna Description of EUT

1. The antenna information is listed as below.

Antenna Type
Loop

* Due to radiated measurements are made and the antenna gain is already accounted for this device, so provide an antenna datasheet and/or antenna measurement report is not required. The antenna dimensions and pictures (include antenna wire length if have) are stated in EUT photo exhibit.

3.3 Channel List

1 channel is provided to this EUT:

Channel	Frequency (MHz)
1	13.56

3.4 Test Mode Applicability and Tested Channel Detail

Pre-Scan:	<ol style="list-style-type: none"> The EUT had been pre-tested on Type A, Type B, Type F and Type V EUT can be used in the following ways: X-axis/ Y-axis/ Z-axis. Pre-scan these ways and find the worst case as a representative test condition.
Worst Case:	<ol style="list-style-type: none"> Type B Z-Axis

Following channel(s) was (were) selected for the final test as listed below:

Test Item	EUT Configure Mode	Mode	Tested Channel	Modulation	Technology Type
AC Power Conducted Emissions	B	NFC	1	ASK	Type B
Radiated Emissions below 30 MHz	A, B	NFC	1	ASK	Type B
Radiated Emissions above 30 MHz	A, B	NFC	1	ASK	Type B
Frequency Stability	A	NFC	1	ASK	Type B
20 dB Bandwidth	A	NFC	1	ASK	Type B
EUT Configure Mode:	A	EUT only			
	B	EUT with docking			

3.5 Test Program Used and Operation Descriptions

Set the EUT under transmission condition continuously at specific channel frequency.

3.6 Connection Diagram of EUT and Peripheral Devices

Test Mode A

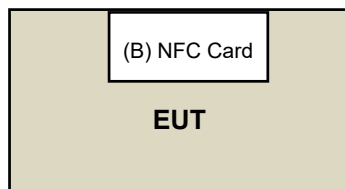

Test Mode B

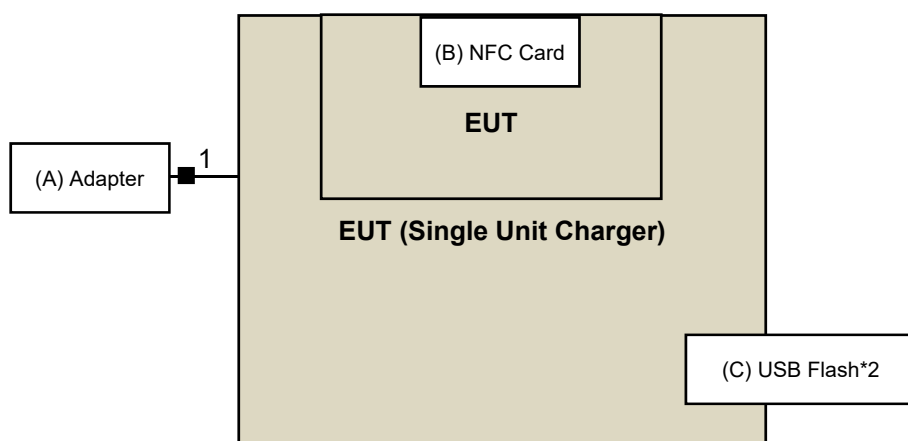

3.7 Configuration of Peripheral Devices and Cable Connections

ID	Product	Brand	Model No.	Serial No.	FCC ID	Remarks
A	Adapter	Motolola	ML36-4145250-A1	N/A	N/A	Accessory of EUT
B	NFC Card	TYPE-B	N/A	N/A	N/A	Provided by Lab
C	USB Flash*2	SanDisk	SDDDC3-032G	N/A	N/A	Provided by Lab

ID	Cable Descriptions	Qty.	Length (m)	Shielding (Yes/No)	Cores (Qty.)	Remarks
1	DC Cable	1	1.5	N	1	Accessory of EUT

4 Test Instruments

The calibration interval of the all test instruments are 12 months and the calibrations are traceable to NML/ROC and NIST/USA.

4.1 AC Power Conducted Emissions

Description Manufacturer	Model No.	Serial No.	Calibrated Date	Calibrated Until
50 ohm terminal resistance HUBER+SUHNER	E1-011315	13	2023/11/22	2024/11/21
50 ohm terminal resistance	E1-011279	04	2023/11/22	2024/11/21
	E1-011280	05	2023/11/22	2024/11/21
DC-LISN Schwarzbeck	NNBM 8126G	8126G-069	2023/11/7	2024/11/6
EMI Test Receiver R&S	ESCI	100412	2023/8/23	2024/8/22
Fixed Attenuator SGH	BNC10W10dB	PAD-COND2-01	2023/9/2	2024/9/1
LISN R&S	ESH2-Z5	100100	2024/3/6	2025/3/5
	ESH3-Z5	100312	2023/9/12	2024/9/11
RF Coaxial Cable Woken	5D-FB	Cable-cond2-01	2023/9/2	2024/9/1
Software BVADT	BVADT_Cond_ V7.4.1.0	N/A	N/A	N/A
V-LISN Schwarzbeck	NNBL 8226-2	8226-142	2023/8/31	2024/8/30

Notes:

1. The test was performed in HY - Conduction 2.
2. Tested Date: 2024/4/24

4.2 Radiated Emissions below 30 MHz

Description Manufacturer	Model No.	Serial No.	Calibrated Date	Calibrated Until
Antenna Tower & Turn Max-Full	MFA-440H	AT93021705	N/A	N/A
EXA Signal Analyzer Agilent	N9010A	MY52220207	2023/12/28	2024/12/27
Loop Antenna Electro-Metrics	EM-6879	269	2023/9/23	2024/9/22
Loop Antenna TESEQ	HLA 6121	45745	2023/8/8	2024/8/7
MXE EMI Receiver Keysight	N9038A	MY55420137	2023/5/3	2024/5/2
Preamplifier EMCI	EMC001340	980201	2023/9/27	2024/9/26
RF Coaxial Cable Woken	8D-FB	Cable-Ch10-01	2023/9/27	2024/9/26
Software BV ADT	ADT_Radiated_ V7.6.15.9.5	N/A	N/A	N/A
Turn Table Max-Full	MFT-201SS	N/A	N/A	N/A
Turn Table Controller Max-Full	MG-7802	N/A	N/A	N/A

Notes:

1. The test was performed in HY - 966 chamber 5.
2. Tested Date: 2024/4/24

4.3 Radiated Emissions above 30 MHz

Description Manufacturer	Model No.	Serial No.	Calibrated Date	Calibrated Until
Antenna Tower & Turn Max-Full	MFA-440H	AT93021705	N/A	N/A
Bi_Log Antenna Schwarzbeck	VULB 9168	9168-472	2023/10/16	2024/10/15
EXA Signal Analyzer Agilent	N9010A	MY52220207	2023/12/28	2024/12/27
Loop Antenna Electro-Metrics	EM-6879	269	2023/9/23	2024/9/22
Loop Antenna TESEQ	HLA 6121	45745	2023/8/8	2024/8/7
MXE EMI Receiver Keysight	N9038A	MY55420137	2023/5/3	2024/5/2
Preamplifier EMCI	EMC 330H	980112	2023/9/27	2024/9/26
	EMC001340	980201	2023/9/27	2024/9/26
RF Coaxial Cable Woken	8D-FB	Cable-Ch10-01	2023/9/27	2024/9/26
Software BV ADT	ADT_Radiated_ V7.6.15.9.5	N/A	N/A	N/A
Turn Table Max-Full	MFT-201SS	N/A	N/A	N/A
Turn Table Controller Max-Full	MG-7802	N/A	N/A	N/A

Notes:

1. The test was performed in HY - 966 chamber 5.
2. Tested Date: 2024/4/24

4.4 Frequency Stability

Description Manufacturer	Model No.	Serial No.	Calibrated Date	Calibrated Until
3-channel DC power supply JIN YIH Technology	ODP3033	ODP30332128138	N/A	N/A
Digital Multimeter Fluke	87III	70360742	2023/7/6	2024/7/5
Signal & Spectrum Analyzer R&S	FSV3044	101504	2023/6/5	2024/6/4
Software BV	ADT_RF Test Software V7.6.5.4	N/A	N/A	N/A
Temperature & Humidity Chamber Terchy	HRM-120RF	931022	2023/12/19	2024/12/18

Notes:

1. The test was performed in Oven room.
2. Tested Date: 2024/4/26

4.5 20 dB Bandwidth

Description Manufacturer	Model No.	Serial No.	Calibrated Date	Calibrated Until
Antenna Tower & Turn Max-Full	MFA-440H	AT93021705	N/A	N/A
EXA Signal Analyzer Agilent	N9010A	MY52220207	2023/12/28	2024/12/27
MXE EMI Receiver Keysight	N9038A	MY55420137	2023/5/3	2024/5/2
Software BV ADT	ADT_Radiated_ V7.6.15.9.5	N/A	N/A	N/A
Turn Table Max-Full	MFT-201SS	N/A	N/A	N/A
Turn Table Controller Max-Full	MG-7802	N/A	N/A	N/A

Notes:

1. The test was performed in HY - 966 chamber 5.
2. Tested Date: 2024/4/26

5 Limits of Test Items

5.1 AC Power Conducted Emissions

Frequency (MHz)	Conducted Limit (dBuV)	
	Quasi-peak	Average
0.15 - 0.5	66 - 56	56 - 46
0.50 - 5.0	56	46
5.0 - 30.0	60	50

Notes:

1. The lower limit shall apply at the transition frequencies.
2. The limit decreases in line with the logarithm of the frequency in the range of 0.15 to 0.50 MHz.

5.2 Radiated Emissions below 30 MHz

- (a) The field strength of any emissions within the band 13.553-13.567 MHz shall not exceed 15,848 microvolts/meter at 30 meters.
- (b) Within the bands 13.410-13.553 MHz and 13.567-13.710 MHz, the field strength of any emissions shall not exceed 334 microvolts/meter at 30 meters.
- (c) Within the bands 13.110-13.410 MHz and 13.710-14.010 MHz the field strength of any emissions shall not exceed 106 microvolts/meter at 30 meters.
- (d) The field strength of any emissions appearing outside of the 13.110-14.010 MHz band shall not exceed the general radiated emission limits in §15.209 as below table:

Frequency (MHz)	Field Strength (microvolts/meter)	Measurement Distance (meters)
0.009 ~ 0.490	2400/F(kHz)	300
0.490 ~ 1.705	24000/F(kHz)	30
1.705 ~ 30.0	30	30

Notes:

1. The lower limit shall apply at the transition frequencies.
2. Emission level (dBuV/m) = 20 log Emission level (uV/m).
3. The emission limits shown in the above table are based on measurements employing a CISPR quasi-peak detect or except for the frequency bands 9-90 kHz, 110-490 kHz and above 1000 MHz. Radiated emission limits in these three bands are based on measurements employing an average detector, and the peak field strength of any emission shall not exceed the maximum permitted average limits, specified above by more than 20 dB under any condition of modulation.

5.3 Radiated Emissions above 30 MHz

Radiated emissions which fall in the restricted bands must comply with the radiated emission limits specified as below table.

Frequency (MHz)	Field Strength (microvolts/meter)	Measurement Distance (meters)
30 ~ 88	100	3
88 ~ 216	150	3
216 ~ 960	200	3
Above 960	500	3

Notes:

1. The lower limit shall apply at the transition frequencies.
2. Emission level (dBuV/m) = 20 log Emission level (uV/m).

5.4 Frequency Stability

The frequency tolerance of the carrier signal shall be maintained within +/- 0.01% of the operating frequency over a temperature variation of -20 degrees to 50 degrees C at normal supply voltage, and for a variation in the primary supply voltage from 85% to 115% of the rated supply voltage at a temperature of 20 degrees C.

5.5 20 dB Bandwidth

The 20dB bandwidth shall be specified in operating frequency band.

6 Test Arrangements

6.1 AC Power Conducted Emissions

6.1.1 Test Setup

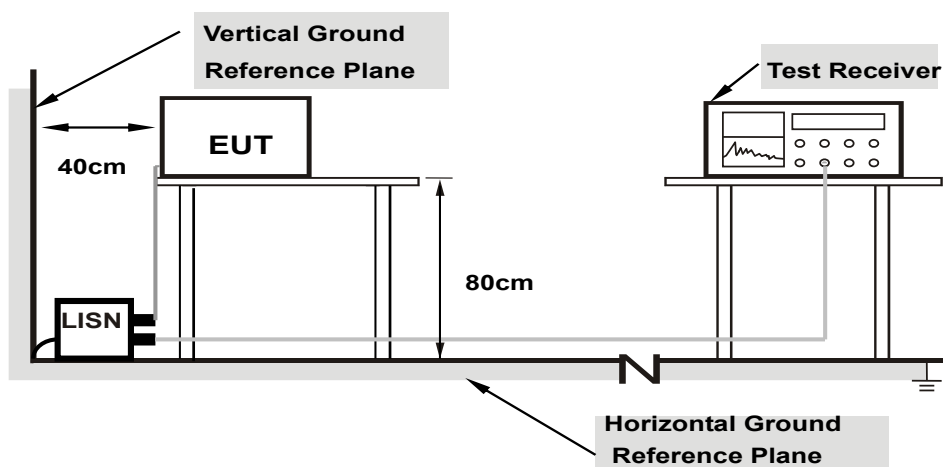

Note: 1.Support units were connected to second LISN.

For the actual test configuration, please refer to the attached file (Test Setup Photo).

6.1.2 Test Procedure

- The EUT was placed on a 0.8 meter to the top of table and placed 0.4 meters from the conducting wall of the shielded room with EUT being connected to the power mains through a line impedance stabilization network (LISN). Other support units were connected to the power mains through another LISN. The two LISNs provide 50 ohm/ 50 uH of coupling impedance for the measuring instrument.
- Both lines of the power mains connected to the EUT were checked for maximum conducted interference.
- The frequency range from 150 kHz to 30 MHz was searched. Emission levels under (Limit – 20 dB) was not recorded.

Note: The resolution bandwidth and video bandwidth of test receiver is 9 kHz for quasi-peak detection (QP) and average detection (AV) at frequency 0.15 MHz-30 MHz.

6.2 Radiated Emissions below 30 MHz

6.2.1 Test Setup

For Radiated emission below 30 MHz

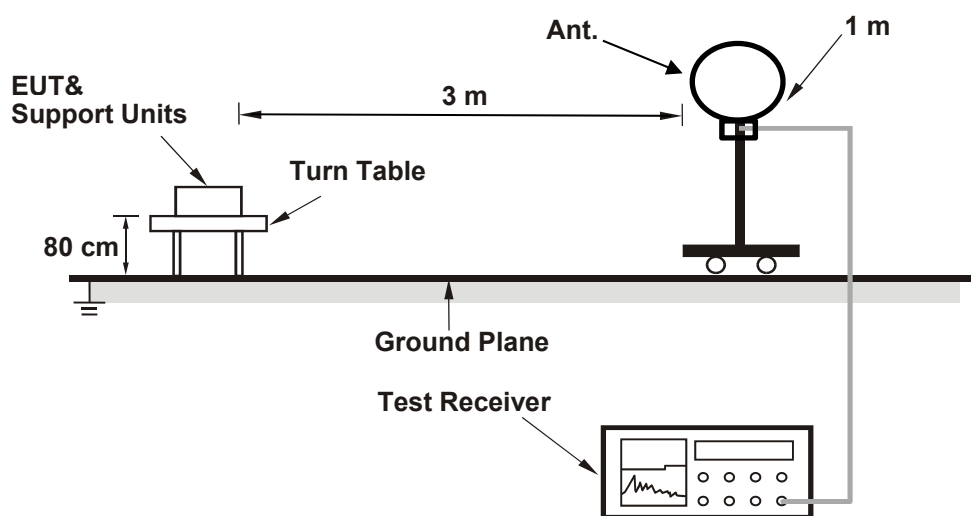

For the actual test configuration, please refer to the attached file (Test Setup Photo).

6.2.2 Test Procedure

For Radiated emission below 30 MHz

- The EUT was placed on the top of a rotating table 0.8 meters above the ground at 3 meter chamber room for test. The table was rotated 360 degrees to determine the position of the highest radiation.
- The EUT was set 3 meters away from the interference-receiving antenna, which was mounted on the top of a variable-height antenna tower.
- Parallel, perpendicular, and ground-parallel orientations of the antenna are set to make the measurement.
- For each suspected emission, the EUT was arranged to its worst case and the rotatable table was turned from 0 degrees to 360 degrees to find the maximum reading.
- The test-receiver system was set to Quasi-Peak Detect Function and Specified Bandwidth with Maximum Hold Mode, except for the frequency band (9 kHz to 90 kHz and 110 kHz to 490 kHz) set to average detect function and peak detect function.

Notes:

- The resolution bandwidth and video bandwidth of test receiver/spectrum analyzer is 200 Hz at frequency below 150 kHz.
- The resolution bandwidth and video bandwidth of test receiver/spectrum analyzer is 9 kHz or 10 kHz at frequency (150 kHz to 30 MHz).
- All modes of operation were investigated and the worst-case emissions are reported.
- KDB 414788 OATS and Chamber Correlation Justification
 - Based on FCC 15.31(f)(2): measurements may be performed at a distance closer than that specified in the regulations; however, an attempt should be made to avoid making measurements in the near field.
 - OATs and chamber correlation testing had been performed and chamber measured test result is the worst case test result.

6.3 Radiated Emissions above 30 MHz

6.3.1 Test Setup

For Radiated emission above 30 MHz

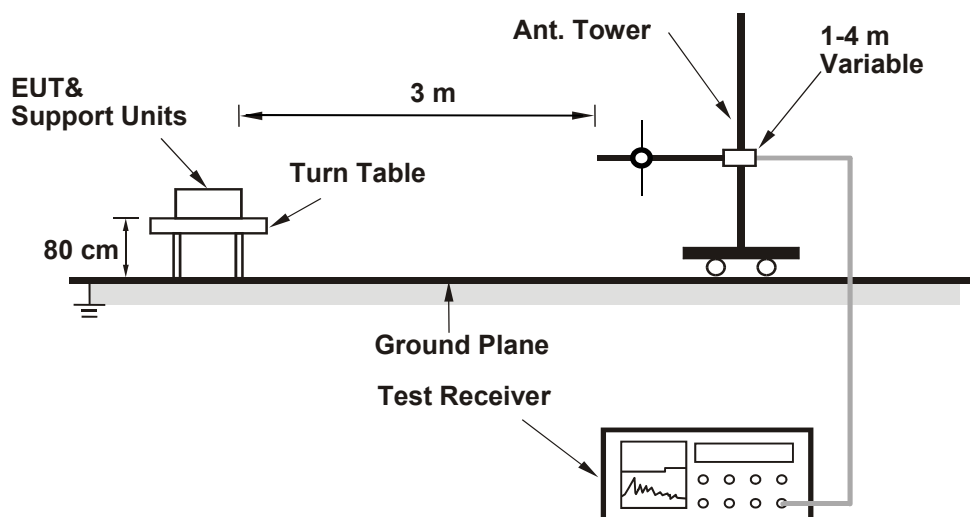

For the actual test configuration, please refer to the attached file (Test Setup Photo).

6.3.2 Test Procedure

For Radiated emission above 30 MHz

- The EUT was placed on the top of a rotating table 0.8 meters above the ground at 3 meter chamber room for test. The table was rotated 360 degrees to determine the position of the highest radiation.
- The EUT was set 3 meters away from the interference-receiving antenna, which was mounted on the top of a variable-height antenna tower.
- The height of antenna is varied from one meter to four meters above the ground to determine the maximum value of the field strength. Both horizontal and vertical polarizations of the antenna are set to make the measurement.
- For each suspected emission, the EUT was arranged to its worst case and then the antenna was tuned to heights from 1 meter to 4 meters and the rotatable table was turned from 0 degrees to 360 degrees to find the maximum reading.
- The test-receiver system was set to quasi-peak detect function and specified bandwidth with maximum hold mode when the test frequency is below 1 GHz.

Notes:

- The resolution bandwidth and video bandwidth of test receiver/spectrum analyzer is 120 kHz for Quasi-peak detection (QP) at frequency below 1 GHz.
- All modes of operation were investigated and the worst-case emissions are reported.

6.4 Frequency Stability

6.4.1 Test Setup

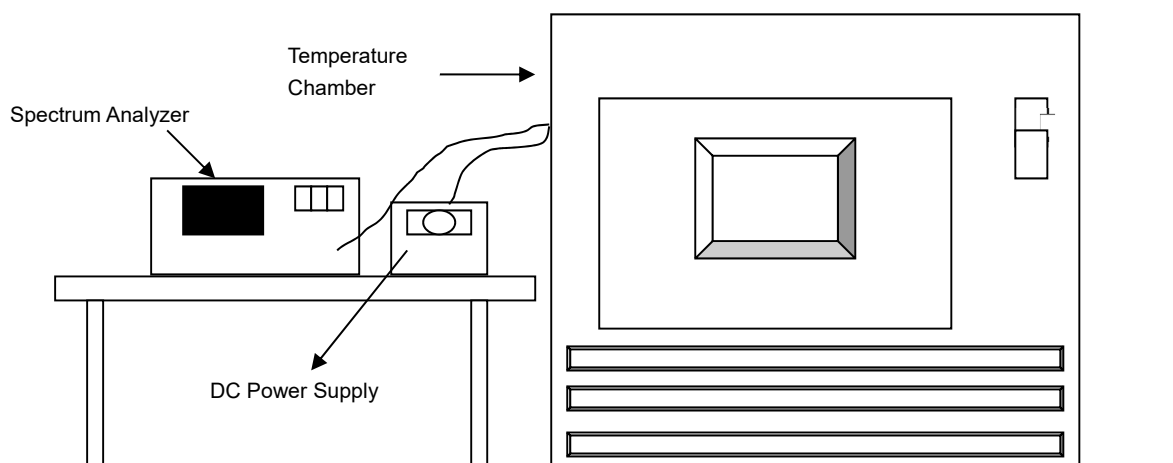

6.4.2 Test Procedure

- The EUT was placed inside the environmental test chamber and powered by nominal DC voltage.
- Turn the EUT on and couple its output to a spectrum analyzer.
- Turn the EUT off and set the chamber to the highest temperature specified.
- Allow sufficient time (approximately 30 min) for the temperature of the chamber to stabilize, turn the EUT on and measure the operating frequency after 2, 5, and 10 Minutes.
- Repeat step (d) with the temperature chamber set to the next desired temperature until measurements down to the lowest specified temperature have been completed.
- The test chamber was allowed to stabilize at +20 degree C for a minimum of 30 Minutes. The supply voltage was then adjusted on the EUT from 85% to 115% and the frequency record.

6.5 20 dB Bandwidth

6.5.1 Test Setup

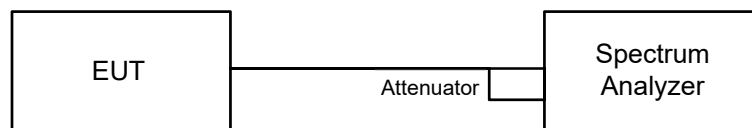

6.5.2 Test Procedure

- a. Set resolution bandwidth (RBW) = 1% to 5% of the OBW.
- b. Set the video bandwidth (VBW) $\geq 3 \times$ RBW, Detector = Peak.
- c. Trace mode = max hold.
- d. Sweep = auto couple.
- e. Measure the maximum width of the emission that is constrained by the frequencies associated with the two amplitude points (upper and lower) that are attenuated by 20 dB relative to the maximum level measured in the fundamental emission.

7 Test Results of Test Item

7.1 AC Power Conducted Emissions

Mode B

RF Mode	NFC-13.56MHz	Channel	CH 1 : 13.56 MHz
Frequency Range	150 kHz ~ 30 MHz	Detector Function & Resolution Bandwidth	Quasi-Peak (QP) / Average (AV), 9 kHz
Input Power	120 Vac, 60 Hz	Environmental Conditions	22°C, 67% RH
Tested By	Vincent Chen		

Phase Of Power : Line (L)

No	Frequency (MHz)	Correction Factor (dB)	Reading Value (dBuV)		Emission Level (dBuV)		Limit (dBuV)		Margin (dB)	
			Q.P.	AV.	Q.P.	AV.	Q.P.	AV.	Q.P.	AV.
1	0.18600	10.41	35.98	18.51	46.39	28.92	64.21	54.21	-17.82	-25.29
2	0.50600	10.52	26.27	10.38	36.79	20.90	56.00	46.00	-19.21	-25.10
3	0.68956	10.53	25.71	10.48	36.24	21.01	56.00	46.00	-19.76	-24.99
4	0.96600	10.56	22.17	5.75	32.73	16.31	56.00	46.00	-23.27	-29.69
5	13.56000	10.88	27.22	27.13	38.10	38.01	60.00	50.00	-21.90	-11.99
6	23.10000	11.14	13.20	5.24	24.34	16.38	60.00	50.00	-35.66	-33.62

Remarks:

1. Q.P. and AV. are abbreviations of quasi-peak and average individually.
2. The emission levels of other frequencies were very low against the limit.
3. Margin value = Emission level – Limit value
4. Correction factor = Insertion loss + Cable loss
5. Emission Level = Correction Factor + Reading Value

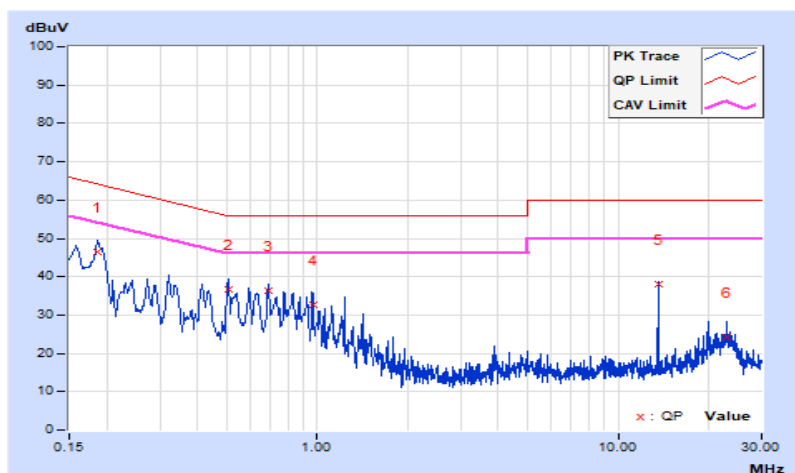

RF Mode	NFC-13.56MHz	Channel	CH 1 : 13.56 MHz
Frequency Range	150 kHz ~ 30 MHz	Detector Function & Resolution Bandwidth	Quasi-Peak (QP) / Average (AV), 9 kHz
Input Power	120 Vac, 60 Hz	Environmental Conditions	22°C, 67% RH
Tested By	Vincent Chen		

Phase Of Power : Neutral (N)										
No	Frequency (MHz)	Correction Factor (dB)	Reading Value (dBuV)		Emission Level (dBuV)		Limit (dBuV)		Margin (dB)	
			Q.P.	AV.	Q.P.	AV.	Q.P.	AV.	Q.P.	AV.
1	0.18200	10.46	34.26	17.39	44.72	27.85	64.39	54.39	-19.67	-26.54
2	0.27400	10.50	22.61	3.20	33.11	13.70	61.00	51.00	-27.89	-37.30
3	0.60200	10.57	22.99	9.53	33.56	20.10	56.00	46.00	-22.44	-25.90
4	0.78600	10.58	22.44	8.85	33.02	19.43	56.00	46.00	-22.98	-26.57
5	13.56000	10.99	26.33	24.99	37.32	35.98	60.00	50.00	-22.68	-14.02
6	20.28800	11.27	14.13	6.86	25.40	18.13	60.00	50.00	-34.60	-31.87

Remarks:

1. Q.P. and AV. are abbreviations of quasi-peak and average individually.
2. The emission levels of other frequencies were very low against the limit.
3. Margin value = Emission level – Limit value
4. Correction factor = Insertion loss + Cable loss
5. Emission Level = Correction Factor + Reading Value

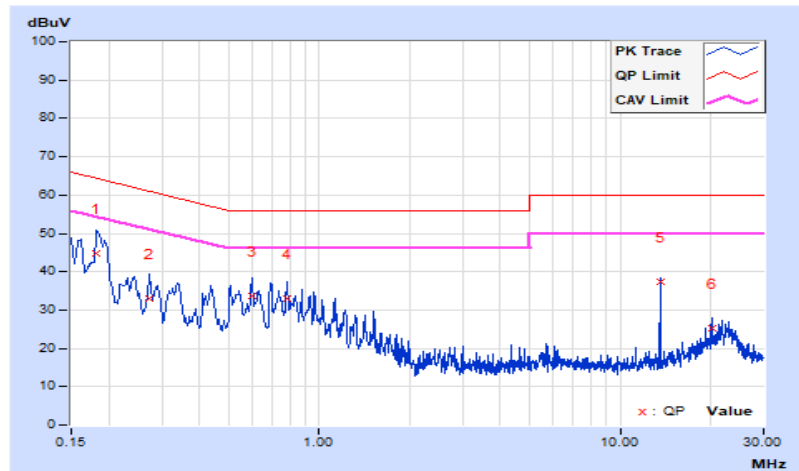

7.2 Radiated Emissions below 30 MHz

Mode A

RF Mode	NFC	Channel	CH 1 : 13.56 MHz
Frequency Range	13.11 MHz ~ 14.01 MHz	Detector Function & Bandwidth	Quasi-Peak (QP), 9 kHz
Input Power	120 Vac, 60 Hz	Environmental Conditions	23°C, 68% RH
Tested By	Vincent Chen		

Antenna Polarity : Parallel

No	Frequency (MHz)	Emission Level (dBuV/m) (30m)	Limit (dBuV/m)	Margin (dB)	Antenna Height (m)	Table Angle (Degree)	Raw Value (dBuV) (3m)	Correction Factor (dB/m)
1	*13.560	18.50 QP	84.00	-65.50	1.00	2	37.10	-18.60

Remarks:

- Emission Level(dBuV/m) = Raw Value(dBuV) + Correction Factor(dB/m)
- Correction Factor(dB/m) = Antenna Factor(dB/m) + Cable Factor(dB) – Pre-Amplifier Factor(dB) + Distance Factor
- Margin value = Emission Level – Limit value
- " * ": Fundamental frequency.
- The test distance for 0.49 ~ 30 MHz is 3 m, extrapolate the measured field strength to a distance of 30 meters.
Distance factor@3 m = $40 \cdot \log(3/30) = -40$ dB

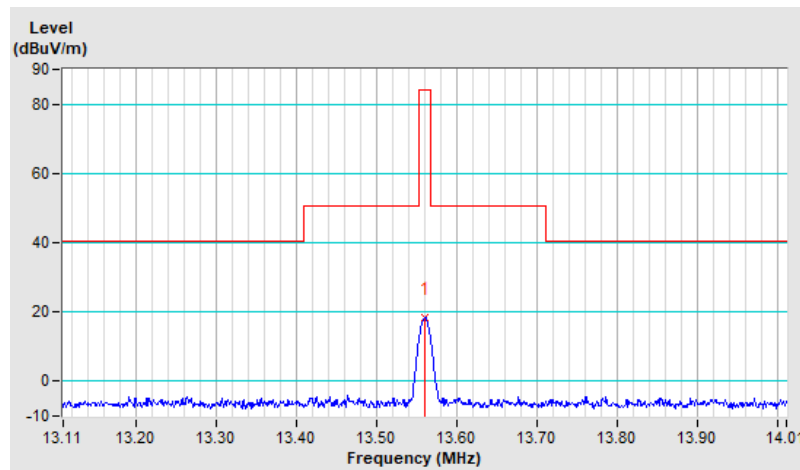

RF Mode	NFC	Channel	CH 1 : 13.56 MHz
Frequency Range	13.11 MHz ~ 14.01 MHz	Detector Function & Bandwidth	Quasi-Peak (QP), 9 kHz
Input Power	120 Vac, 60 Hz	Environmental Conditions	23°C, 68% RH
Tested By	Vincent Chen		

Antenna Polarity : Perpendicular

No	Frequency (MHz)	Emission Level (dBuV/m) (30m)	Limit (dBuV/m)	Margin (dB)	Antenna Height (m)	Table Angle (Degree)	Raw Value (dBuV) (3m)	Correction Factor (dB/m)
1	*13.560	14.20 QP	84.00	-69.80	1.00	254	32.80	-18.60

Remarks:

1. Emission Level(dBuV/m) = Raw Value(dBuV) + Correction Factor(dB/m)
2. Correction Factor(dB/m) = Antenna Factor(dB/m) + Cable Factor(dB) – Pre-Amplifier Factor(dB) + Distance Factor
3. Margin value = Emission Level – Limit value
4. " * " : Fundamental frequency.
5. The test distance for 0.49 ~ 30 MHz is 3 m, extrapolate the measured field strength to a distance of 30 meters.
Distance factor@3 m = $40 \cdot \log(3/30) = -40$ dB

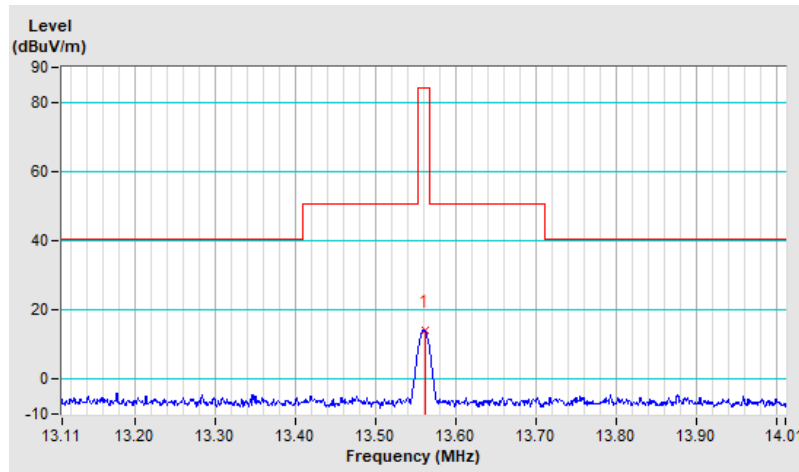

RF Mode	NFC	Channel	CH 1 : 13.56 MHz
Frequency Range	13.11 MHz ~ 14.01 MHz	Detector Function & Bandwidth	Quasi-Peak (QP), 9 kHz
Input Power	120 Vac, 60 Hz	Environmental Conditions	23°C, 68% RH
Tested By	Vincent Chen		

Antenna Polarity : Ground-parallel								
No	Frequency (MHz)	Emission Level (dBuV/m) (30m)	Limit (dBuV/m)	Margin (dB)	Antenna Height (m)	Table Angle (Degree)	Raw Value (dBuV) (3m)	Correction Factor (dB/m)
1	*13.560	12.60 QP	84.00	-71.40	1.00	2	31.20	-18.60

Remarks:

1. Emission Level(dBuV/m) = Raw Value(dBuV) + Correction Factor(dB/m)
2. Correction Factor(dB/m) = Antenna Factor(dB/m) + Cable Factor(dB) – Pre-Amplifier Factor(dB) + Distance Factor
3. Margin value = Emission Level – Limit value
4. " * " : Fundamental frequency.
5. The test distance for 0.49 ~ 30 MHz is 3 m, extrapolate the measured field strength to a distance of 30 meters.
Distance factor@3 m = $40 \cdot \log(3/30) = -40$ dB

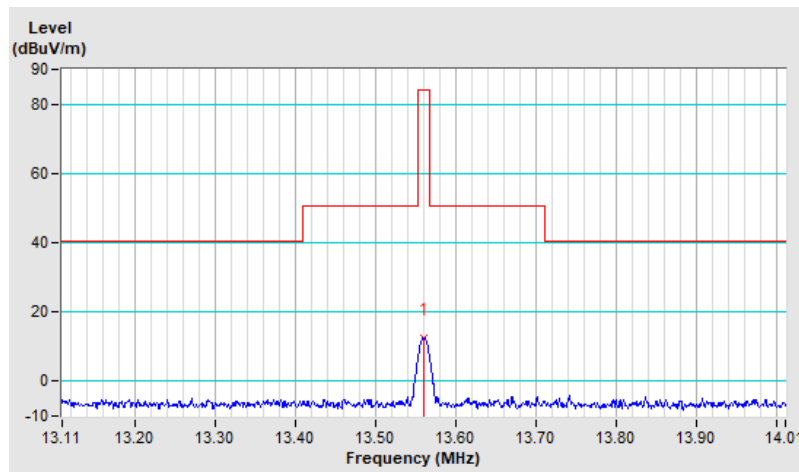

RF Mode	NFC	Channel	CH 1 : 13.56 MHz
Frequency Range	9 kHz ~ 30 MHz	Detector Function & Bandwidth	Quasi-Peak (QP), 9 kHz
Input Power	120 Vac, 60 Hz	Environmental Conditions	23°C, 68% RH
Tested By	Vincent Chen		

Antenna Polarity : Parallel								
No	Frequency (MHz)	Emission Level (dBuV/m) (30m)	Limit (dBuV/m)	Margin (dB)	Antenna Height (m)	Table Angle (Degree)	Raw Value (dBuV) (3m)	Correction Factor (dB/m)
1	4.480	-6.80 QP	29.50	-36.30	1.00	209	13.40	-20.20
2	10.720	-5.60 QP	29.50	-35.10	1.00	347	12.90	-18.50
3	16.770	-4.40 QP	29.50	-33.90	1.00	254	13.70	-18.10
4	20.160	-4.20 QP	29.50	-33.70	1.00	303	13.70	-17.90
5	24.180	-5.10 QP	29.50	-34.60	1.00	342	13.10	-18.20
6	27.120	-6.30 QP	29.50	-35.80	1.00	11	11.50	-17.80

Remarks:

1. Emission Level(dBuV/m) = Raw Value(dBuV) + Correction Factor(dB/m)
2. Correction Factor(dB/m) = Antenna Factor(dB/m) + Cable Factor(dB) – Pre-Amplifier Factor(dB) + Distance Factor
3. Margin value = Emission Level – Limit value
4. The other emission levels were very low against the limit.
5. The test distance for 0.49 ~ 30 MHz is 3 m, extrapolate the measured field strength to a distance of 30 meters.
Distance factor@3 m = $40 \cdot \log(3/30) = -40$ dB

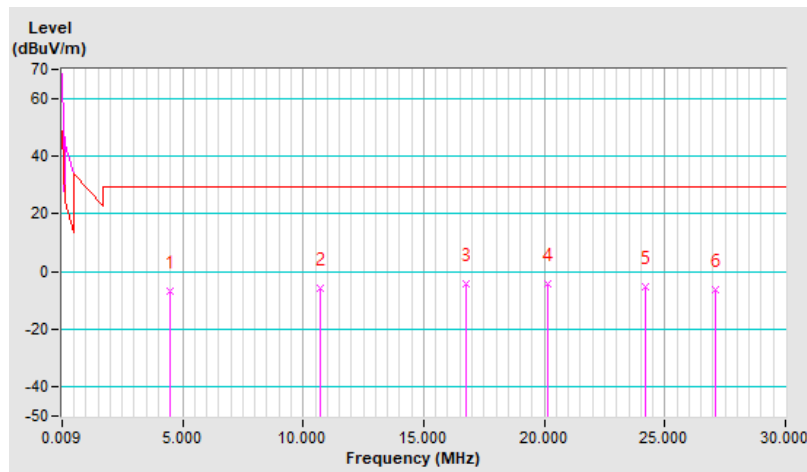

RF Mode	NFC	Channel	CH 1 : 13.56 MHz
Frequency Range	9 kHz ~ 30 MHz	Detector Function & Bandwidth	Quasi-Peak (QP), 9 kHz
Input Power	120 Vac, 60 Hz	Environmental Conditions	23°C, 68% RH
Tested By	Vincent Chen		

Antenna Polarity : Perpendicular

No	Frequency (MHz)	Emission Level (dBuV/m) (30m)	Limit (dBuV/m)	Margin (dB)	Antenna Height (m)	Table Angle (Degree)	Raw Value (dBuV) (3m)	Correction Factor (dB/m)
1	4.690	-7.10 QP	29.50	-36.60	1.00	138	13.00	-20.10
2	9.910	-5.90 QP	29.50	-35.40	1.00	288	12.70	-18.60
3	15.510	-5.20 QP	29.50	-34.70	1.00	328	13.30	-18.50
4	19.920	-5.00 QP	29.50	-34.50	1.00	192	12.90	-17.90
5	23.970	-5.40 QP	29.50	-34.90	1.00	1	13.00	-18.40
6	27.120	-6.00 QP	29.50	-35.50	1.00	312	11.80	-17.80

Remarks:

1. Emission Level(dBuV/m) = Raw Value(dBuV) + Correction Factor(dB/m)
2. Correction Factor(dB/m) = Antenna Factor(dB/m) + Cable Factor(dB) – Pre-Amplifier Factor(dB) + Distance Factor
3. Margin value = Emission Level – Limit value
4. The other emission levels were very low against the limit.
5. The test distance for 0.49 ~ 30 MHz is 3 m, extrapolate the measured field strength to a distance of 30 meters.
Distance factor@3 m = $40 \cdot \log(3/30) = -40$ dB

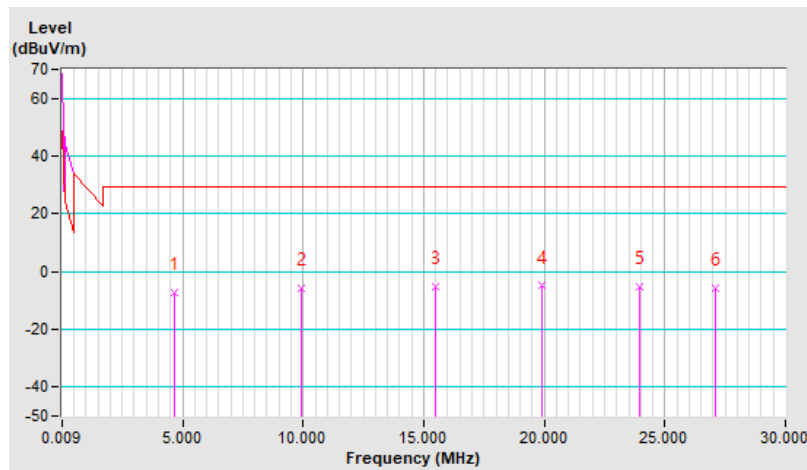

RF Mode	NFC	Channel	CH 1 : 13.56 MHz
Frequency Range	9 kHz ~ 30 MHz	Detector Function & Bandwidth	Quasi-Peak (QP), 9 kHz
Input Power	120 Vac, 60 Hz	Environmental Conditions	23°C, 68% RH
Tested By	Vincent Chen		

Antenna Polarity : Ground-parallel								
No	Frequency (MHz)	Emission Level (dBuV/m) (30m)	Limit (dBuV/m)	Margin (dB)	Antenna Height (m)	Table Angle (Degree)	Raw Value (dBuV) (3m)	Correction Factor (dB/m)
1	4.270	-7.10 QP	29.50	-36.60	1.00	51	13.10	-20.20
2	8.410	-5.80 QP	29.50	-35.30	1.00	138	13.10	-18.90
3	15.540	-5.10 QP	29.50	-34.60	1.00	325	13.40	-18.50
4	18.660	-4.80 QP	29.50	-34.30	1.00	46	13.00	-17.80
5	24.270	-5.60 QP	29.50	-35.10	1.00	162	12.50	-18.10
6	27.120	-5.70 QP	29.50	-35.20	1.00	310	12.10	-17.80

Remarks:

1. Emission Level(dBuV/m) = Raw Value(dBuV) + Correction Factor(dB/m)
2. Correction Factor(dB/m) = Antenna Factor(dB/m) + Cable Factor(dB) – Pre-Amplifier Factor(dB) + Distance Factor
3. Margin value = Emission Level – Limit value
4. The other emission levels were very low against the limit.
5. The test distance for 0.49 ~ 30 MHz is 3 m, extrapolate the measured field strength to a distance of 30 meters.
Distance factor@3 m = $40 \cdot \log(3/30) = -40$ dB

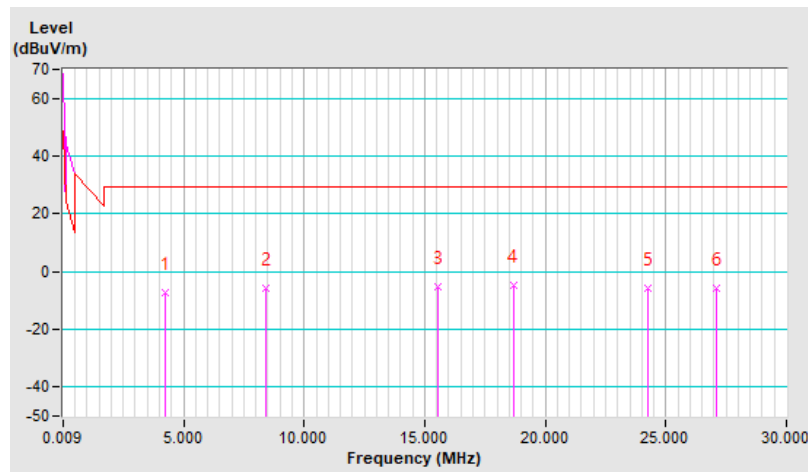

Mode B

RF Mode	NFC	Channel	CH 1 : 13.56 MHz
Frequency Range	13.11 MHz ~ 14.01 MHz	Detector Function & Bandwidth	Quasi-Peak (QP), 9 kHz
Input Power	120 Vac, 60 Hz	Environmental Conditions	23°C, 68% RH
Tested By	Vincent Chen		

Antenna Polarity : Parallel								
No	Frequency (MHz)	Emission Level (dBuV/m) (30m)	Limit (dBuV/m)	Margin (dB)	Antenna Height (m)	Table Angle (Degree)	Raw Value (dBuV) (3m)	Correction Factor (dB/m)
1	*13.560	18.60 QP	84.00	-65.40	1.00	178	37.20	-18.60

Remarks:

1. Emission Level(dBuV/m) = Raw Value(dBuV) + Correction Factor(dB/m)
2. Correction Factor(dB/m) = Antenna Factor(dB/m) + Cable Factor(dB) – Pre-Amplifier Factor(dB) + Distance Factor
3. Margin value = Emission Level – Limit value
4. " * " : Fundamental frequency.
5. The test distance for 0.49 ~ 30 MHz is 3 m, extrapolate the measured field strength to a distance of 30 meters.
Distance factor@3 m = $40 \cdot \log(3/30) = -40$ dB

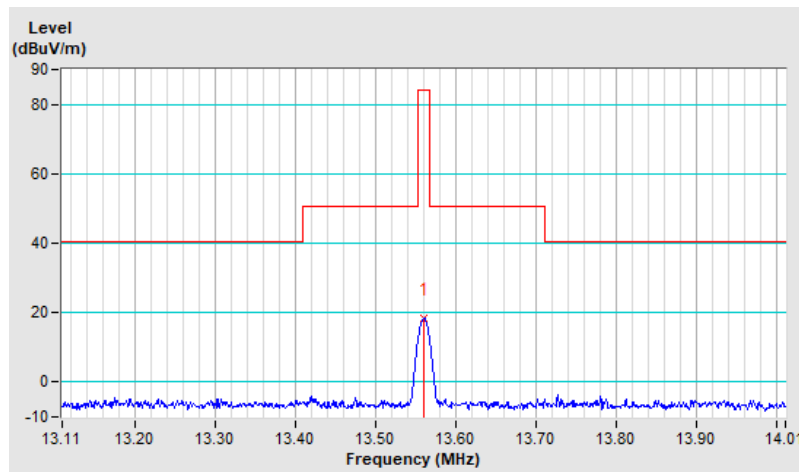

RF Mode	NFC	Channel	CH 1 : 13.56 MHz
Frequency Range	13.11 MHz ~ 14.01 MHz	Detector Function & Bandwidth	Quasi-Peak (QP), 9 kHz
Input Power	120 Vac, 60 Hz	Environmental Conditions	23°C, 68% RH
Tested By	Vincent Chen		

Antenna Polarity : Perpendicular								
No	Frequency (MHz)	Emission Level (dBuV/m) (30m)	Limit (dBuV/m)	Margin (dB)	Antenna Height (m)	Table Angle (Degree)	Raw Value (dBuV) (3m)	Correction Factor (dB/m)
1	*13.560	15.30 QP	84.00	-68.70	1.00	266	33.90	-18.60

Remarks:

1. Emission Level(dBuV/m) = Raw Value(dBuV) + Correction Factor(dB/m)
2. Correction Factor(dB/m) = Antenna Factor(dB/m) + Cable Factor(dB) – Pre-Amplifier Factor(dB) + Distance Factor
3. Margin value = Emission Level – Limit value
4. " * " : Fundamental frequency.
5. The test distance for 0.49 ~ 30 MHz is 3 m, extrapolate the measured field strength to a distance of 30 meters.
Distance factor@3 m = $40 \cdot \log(3/30) = -40$ dB

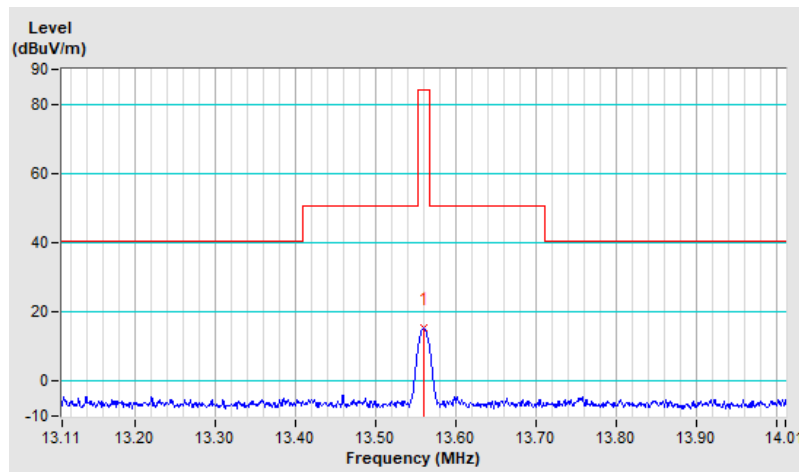

RF Mode	NFC	Channel	CH 1 : 13.56 MHz
Frequency Range	13.11 MHz ~ 14.01 MHz	Detector Function & Bandwidth	Quasi-Peak (QP), 9 kHz
Input Power	120 Vac, 60 Hz	Environmental Conditions	23°C, 68% RH
Tested By	Vincent Chen		

Antenna Polarity : Ground-parallel								
No	Frequency (MHz)	Emission Level (dBuV/m) (30m)	Limit (dBuV/m)	Margin (dB)	Antenna Height (m)	Table Angle (Degree)	Raw Value (dBuV) (3m)	Correction Factor (dB/m)
1	*13.560	11.50 QP	84.00	-72.50	1.00	182	30.10	-18.60

Remarks:

1. Emission Level(dBuV/m) = Raw Value(dBuV) + Correction Factor(dB/m)
2. Correction Factor(dB/m) = Antenna Factor(dB/m) + Cable Factor(dB) – Pre-Amplifier Factor(dB) + Distance Factor
3. Margin value = Emission Level – Limit value
4. " * " : Fundamental frequency.
5. The test distance for 0.49 ~ 30 MHz is 3 m, extrapolate the measured field strength to a distance of 30 meters.
Distance factor@3 m = $40 \cdot \log(3/30) = -40$ dB

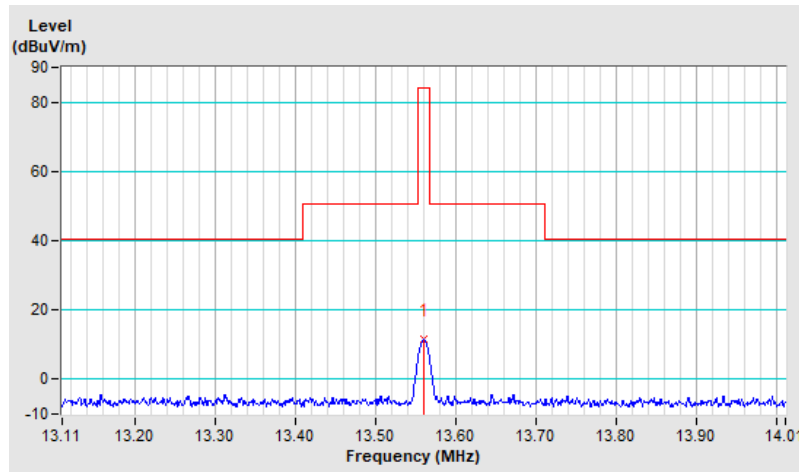

RF Mode	NFC	Channel	CH 1 : 13.56 MHz
Frequency Range	9 kHz ~ 30 MHz	Detector Function & Bandwidth	Quasi-Peak (QP), 9 kHz
Input Power	120 Vac, 60 Hz	Environmental Conditions	23°C, 68% RH
Tested By	Vincent Chen		

Antenna Polarity : Parallel

No	Frequency (MHz)	Emission Level (dBuV/m) (30m)	Limit (dBuV/m)	Margin (dB)	Antenna Height (m)	Table Angle (Degree)	Raw Value (dBuV) (3m)	Correction Factor (dB/m)
1	5.740	-7.10 QP	29.50	-36.60	1.00	256	12.00	-19.10
2	7.930	-5.90 QP	29.50	-35.40	1.00	198	13.00	-18.90
3	17.190	-4.50 QP	29.50	-34.00	1.00	211	13.50	-18.00
4	21.990	-5.10 QP	29.50	-34.60	1.00	64	13.10	-18.20
5	25.350	-5.20 QP	29.50	-34.70	1.00	85	12.40	-17.60
6	27.120	-6.40 QP	29.50	-35.90	1.00	313	11.40	-17.80

Remarks:

1. Emission Level(dBuV/m) = Raw Value(dBuV) + Correction Factor(dB/m)
2. Correction Factor(dB/m) = Antenna Factor(dB/m) + Cable Factor(dB) – Pre-Amplifier Factor(dB) + Distance Factor
3. Margin value = Emission Level – Limit value
4. The other emission levels were very low against the limit.
5. The test distance for 0.49 ~ 30 MHz is 3 m, extrapolate the measured field strength to a distance of 30 meters.
Distance factor@3 m = $40 \cdot \log(3/30) = -40$ dB

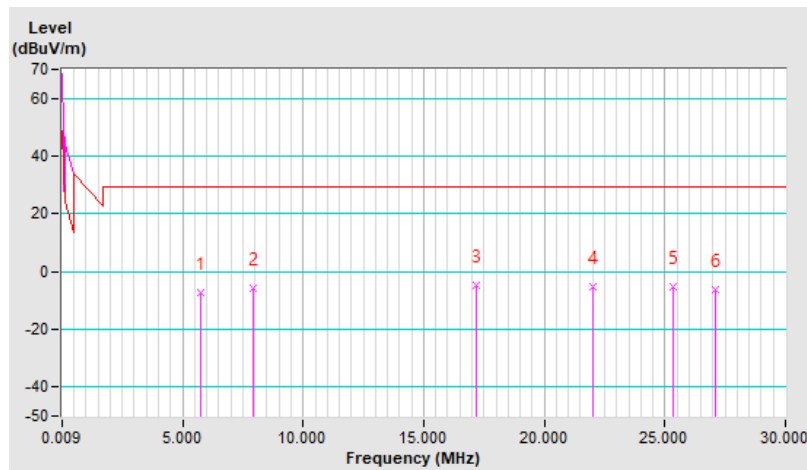

RF Mode	NFC	Channel	CH 1 : 13.56 MHz
Frequency Range	9 kHz ~ 30 MHz	Detector Function & Bandwidth	Quasi-Peak (QP), 9 kHz
Input Power	120 Vac, 60 Hz	Environmental Conditions	23°C, 68% RH
Tested By	Vincent Chen		

Antenna Polarity : Perpendicular

No	Frequency (MHz)	Emission Level (dBuV/m) (30m)	Limit (dBuV/m)	Margin (dB)	Antenna Height (m)	Table Angle (Degree)	Raw Value (dBuV) (3m)	Correction Factor (dB/m)
1	4.270	-7.40 QP	29.50	-36.90	1.00	328	12.80	-20.20
2	7.900	-5.40 QP	29.50	-34.90	1.00	109	13.50	-18.90
3	16.590	-4.20 QP	29.50	-33.70	1.00	244	14.00	-18.20
4	21.300	-5.00 QP	29.50	-34.50	1.00	203	13.20	-18.20
5	25.260	-4.80 QP	29.50	-34.30	1.00	153	12.80	-17.60
6	27.120	-6.30 QP	29.50	-35.80	1.00	18	11.50	-17.80

Remarks:

1. Emission Level(dBuV/m) = Raw Value(dBuV) + Correction Factor(dB/m)
2. Correction Factor(dB/m) = Antenna Factor(dB/m) + Cable Factor(dB) – Pre-Amplifier Factor(dB) + Distance Factor
3. Margin value = Emission Level – Limit value
4. The other emission levels were very low against the limit.
5. The test distance for 0.49 ~ 30 MHz is 3 m, extrapolate the measured field strength to a distance of 30 meters.
Distance factor@3 m = $40 \cdot \log(3/30) = -40$ dB

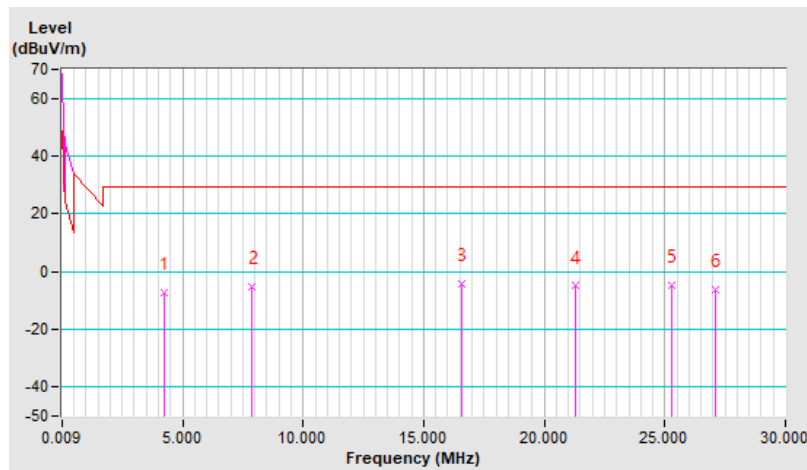



RF Mode	NFC	Channel	CH 1 : 13.56 MHz
Frequency Range	9 kHz ~ 30 MHz	Detector Function & Bandwidth	Quasi-Peak (QP), 9 kHz
Input Power	120 Vac, 60 Hz	Environmental Conditions	23°C, 68% RH
Tested By	Vincent Chen		

Antenna Polarity : Ground-parallel								
No	Frequency (MHz)	Emission Level (dBuV/m) (30m)	Limit (dBuV/m)	Margin (dB)	Antenna Height (m)	Table Angle (Degree)	Raw Value (dBuV) (3m)	Correction Factor (dB/m)
1	2.950	-5.50 QP	29.50	-35.00	1.00	245	15.00	-20.50
2	8.050	-5.90 QP	29.50	-35.40	1.00	9	13.00	-18.90
3	15.000	-5.40 QP	29.50	-34.90	1.00	61	13.20	-18.60
4	18.480	-4.90 QP	29.50	-34.40	1.00	82	13.00	-17.90
5	22.830	-5.60 QP	29.50	-35.10	1.00	242	12.90	-18.50
6	27.120	-6.00 QP	29.50	-35.50	1.00	37	11.80	-17.80

Remarks:

1. Emission Level(dBuV/m) = Raw Value(dBuV) + Correction Factor(dB/m)
2. Correction Factor(dB/m) = Antenna Factor(dB/m) + Cable Factor(dB) – Pre-Amplifier Factor(dB) + Distance Factor
3. Margin value = Emission Level – Limit value
4. The other emission levels were very low against the limit.
5. The test distance for 0.49 ~ 30 MHz is 3 m, extrapolate the measured field strength to a distance of 30 meters.
Distance factor@3 m = $40 \cdot \log(3/30) = -40$ dB

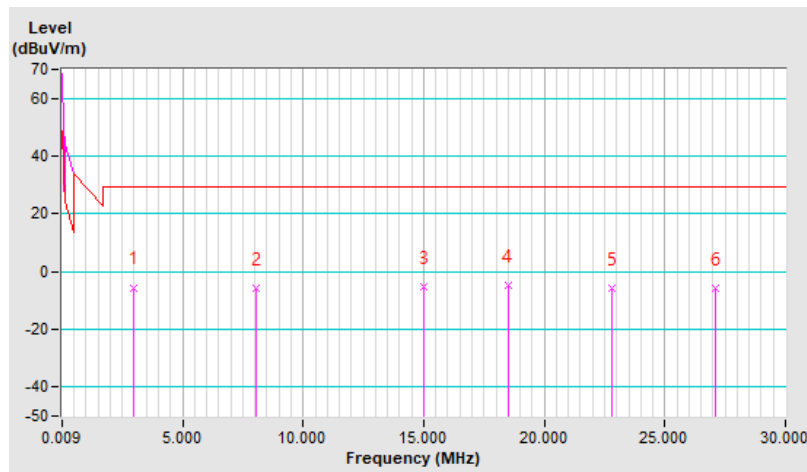

7.3 Radiated Emissions above 30 MHz

Mode A

RF Mode	NFC-13.56MHz	Channel	CH 1 : 13.56 MHz
Frequency Range	30 MHz ~ 1 GHz	Detector Function & Bandwidth	QP: RB=120kHz, DET=Quasi-Peak
Input Power	120 Vac, 60 Hz	Environmental Conditions	23°C, 68% RH
Tested By	Vincent Chen		

Antenna Polarity & Test Distance : Horizontal at 3 m

No	Frequency (MHz)	Emission Level (dBuV/m)	Limit (dBuV/m)	Margin (dB)	Antenna Height (m)	Table Angle (Degree)	Raw Value (dBuV)	Correction Factor (dB/m)
1	78.50	29.7 QP	40.0	-10.3	2.00 H	139	46.7	-17.0
2	148.34	22.3 QP	43.5	-21.2	1.00 H	283	35.1	-12.8
3	379.20	21.6 QP	46.0	-24.4	1.50 H	93	31.7	-10.1
4	599.39	25.5 QP	46.0	-20.5	1.00 H	170	30.7	-5.2
5	866.14	30.3 QP	46.0	-15.7	1.00 H	35	31.2	-0.9
6	935.98	30.3 QP	46.0	-15.7	2.00 H	199	30.8	-0.5

Remarks:

1. Emission Level(dBuV/m) = Raw Value(dBuV) + Correction Factor(dB/m)
2. Correction Factor(dB/m) = Antenna Factor(dB/m) + Cable Factor(dB) – Pre-Amplifier Factor(dB)
3. Margin value = Emission Level – Limit value
4. The other emission levels were very low against the limit of frequency range 30 MHz ~ 1 GHz.
5. The frequency range 9 kHz ~ 30 MHz: all emissions are more than 20 dB below the limit, therefore do not be recorded in this report.

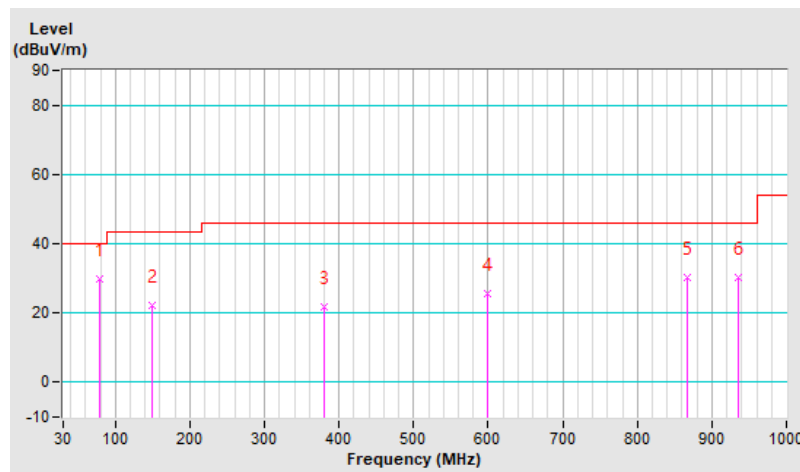

RF Mode	NFC-13.56MHz	Channel	CH 1 : 13.56 MHz
Frequency Range	30 MHz ~ 1 GHz	Detector Function & Bandwidth	QP: RB=120kHz, DET=Quasi-Peak
Input Power	120 Vac, 60 Hz	Environmental Conditions	23°C, 68% RH
Tested By	Vincent Chen		

Antenna Polarity & Test Distance : Vertical at 3 m								
No	Frequency (MHz)	Emission Level (dBuV/m)	Limit (dBuV/m)	Margin (dB)	Antenna Height (m)	Table Angle (Degree)	Raw Value (dBuV)	Correction Factor (dB/m)
1	53.28	33.5 QP	40.0	-6.5	1.00 V	214	46.0	-12.5
2	148.34	24.2 QP	43.5	-19.3	1.50 V	186	37.0	-12.8
3	340.40	21.2 QP	46.0	-24.8	1.00 V	144	32.5	-11.3
4	492.69	24.4 QP	46.0	-21.6	1.00 V	253	31.6	-7.2
5	678.93	27.6 QP	46.0	-18.4	2.00 V	325	31.2	-3.6
6	903.00	31.0 QP	46.0	-15.0	1.50 V	136	31.7	-0.7

Remarks:

1. Emission Level(dBuV/m) = Raw Value(dBuV) + Correction Factor(dB/m)
2. Correction Factor(dB/m) = Antenna Factor(dB/m) + Cable Factor(dB) – Pre-Amplifier Factor(dB)
3. Margin value = Emission Level – Limit value
4. The other emission levels were very low against the limit of frequency range 30 MHz ~ 1 GHz.
5. The frequency range 9 kHz ~ 30 MHz: all emissions are more than 20 dB below the limit, therefore do not be recorded in this report.

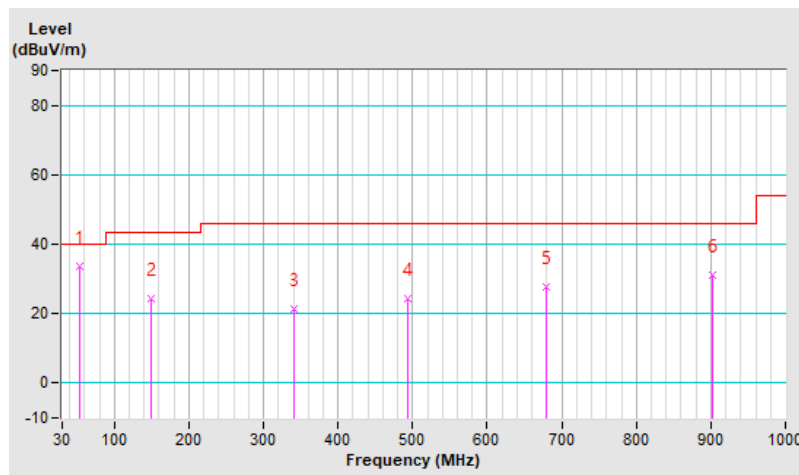

Mode B

RF Mode	NFC-13.56MHz	Channel	CH 1 : 13.56 MHz
Frequency Range	30 MHz ~ 1 GHz	Detector Function & Bandwidth	QP: RB=120kHz, DET=Quasi-Peak
Input Power	120 Vac, 60 Hz	Environmental Conditions	23°C, 68% RH
Tested By	Vincent Chen		

Antenna Polarity & Test Distance : Horizontal at 3 m

No	Frequency (MHz)	Emission Level (dBuV/m)	Limit (dBuV/m)	Margin (dB)	Antenna Height (m)	Table Angle (Degree)	Raw Value (dBuV)	Correction Factor (dB/m)
1	77.53	29.7 QP	40.0	-10.3	2.00 H	62	46.5	-16.8
2	148.34	26.1 QP	43.5	-17.4	1.00 H	70	38.9	-12.8
3	411.21	22.8 QP	46.0	-23.2	1.50 H	262	32.2	-9.4
4	594.54	27.0 QP	46.0	-19.0	1.00 H	34	32.3	-5.3
5	741.98	28.8 QP	46.0	-17.2	1.00 H	84	30.5	-1.7
6	843.83	29.8 QP	46.0	-16.2	1.50 H	2	30.9	-1.1

Remarks:

1. Emission Level(dBuV/m) = Raw Value(dBuV) + Correction Factor(dB/m)
2. Correction Factor(dB/m) = Antenna Factor(dB/m) + Cable Factor(dB) – Pre-Amplifier Factor(dB)
3. Margin value = Emission Level – Limit value
4. The other emission levels were very low against the limit of frequency range 30 MHz ~ 1 GHz.
5. The frequency range 9 kHz ~ 30 MHz: all emissions are more than 20 dB below the limit, therefore do not be recorded in this report.

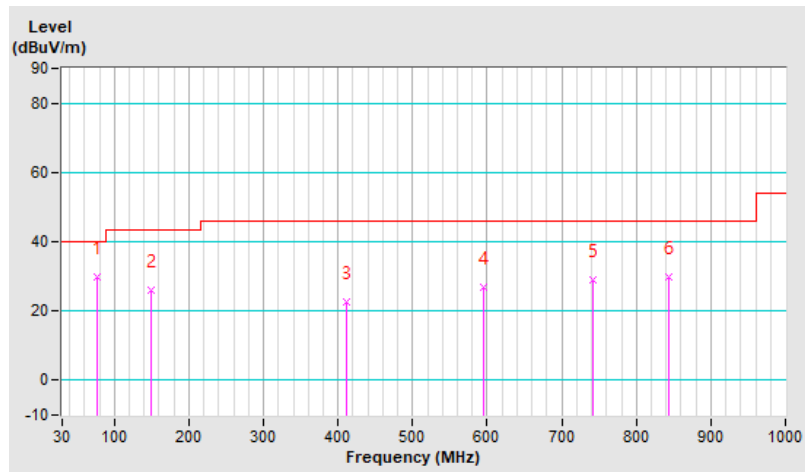

RF Mode	NFC-13.56MHz	Channel	CH 1 : 13.56 MHz
Frequency Range	30 MHz ~ 1 GHz	Detector Function & Bandwidth	QP: RB=120kHz, DET=Quasi-Peak
Input Power	120 Vac, 60 Hz	Environmental Conditions	23°C, 68% RH
Tested By	Vincent Chen		

Antenna Polarity & Test Distance : Vertical at 3 m								
No	Frequency (MHz)	Emission Level (dBuV/m)	Limit (dBuV/m)	Margin (dB)	Antenna Height (m)	Table Angle (Degree)	Raw Value (dBuV)	Correction Factor (dB/m)
1	53.28	34.4 QP	40.0	-5.6	1.00 V	142	46.9	-12.5
2	135.73	25.9 QP	43.5	-17.6	1.00 V	202	39.2	-13.3
3	366.59	21.9 QP	46.0	-24.1	1.50 V	270	32.4	-10.5
4	547.98	25.3 QP	46.0	-20.7	1.00 V	173	31.5	-6.2
5	741.98	29.6 QP	46.0	-16.4	2.00 V	339	31.3	-1.7
6	872.93	30.0 QP	46.0	-16.0	1.50 V	183	30.8	-0.8

Remarks:

1. Emission Level(dBuV/m) = Raw Value(dBuV) + Correction Factor(dB/m)
2. Correction Factor(dB/m) = Antenna Factor(dB/m) + Cable Factor(dB) – Pre-Amplifier Factor(dB)
3. Margin value = Emission Level – Limit value
4. The other emission levels were very low against the limit of frequency range 30 MHz ~ 1 GHz.
5. The frequency range 9 kHz ~ 30 MHz: all emissions are more than 20 dB below the limit, therefore do not be recorded in this report.

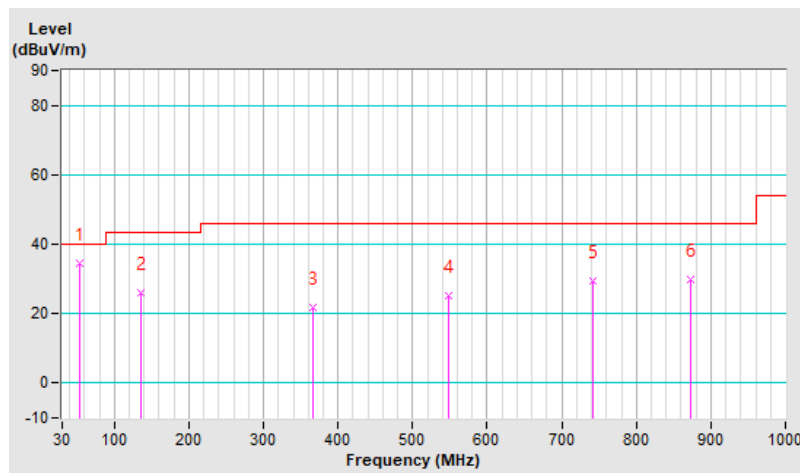

7.4 Frequency Stability

Environmental Conditions:	25°C, 60% RH	Tested By:	Vincent Chen
---------------------------	--------------	------------	--------------

Frequency Stability Versus Temperature									
Operating Frequency: 13.56 MHz									
Temp. (°C)	Power Supply (Vdc)	0 Minute		2 Minutes		5 Minutes		10 Minutes	
		Measured Frequency (MHz)	Frequency Drift (%)	Measured Frequency (MHz)	Frequency Drift (%)	Measured Frequency (MHz)	Frequency Drift (%)	Measured Frequency (MHz)	Frequency Drift (%)
60	7.5	13.55997	-0.00022	13.55998	-0.00015	13.55997	-0.00022	13.55997	-0.00022
50	7.5	13.55993	-0.00052	13.55993	-0.00052	13.55993	-0.00052	13.55993	-0.00052
40	7.5	13.56005	0.00037	13.56005	0.00037	13.56005	0.00037	13.56005	0.00037
30	7.5	13.55995	-0.00037	13.55994	-0.00044	13.55995	-0.00037	13.55996	-0.00029
20	7.5	13.55998	-0.00015	13.55997	-0.00022	13.55999	-0.00007	13.55998	-0.00015
10	7.5	13.55997	-0.00022	13.55997	-0.00022	13.55997	-0.00022	13.55997	-0.00022
0	7.5	13.56003	0.00022	13.56003	0.00022	13.56002	0.00015	13.56002	0.00015
-10	7.5	13.56002	0.00015	13.56001	0.00007	13.56003	0.00022	13.56002	0.00015
-20	7.5	13.56004	0.00029	13.56004	0.00029	13.56005	0.00037	13.56004	0.00029

Frequency Stability Versus Voltage									
Operating Frequency: 13.56 MHz									
Temp. (°C)	Power Supply (Vdc)	0 Minute		2 Minutes		5 Minutes		10 Minutes	
		Measured Frequency (MHz)	Frequency Drift (%)	Measured Frequency (MHz)	Frequency Drift (%)	Measured Frequency (MHz)	Frequency Drift (%)	Measured Frequency (MHz)	Frequency Drift (%)
20	8.625	13.55998	-0.00015	13.55997	-0.00022	13.55999	-0.00007	13.55998	-0.00015
	7.5	13.55998	-0.00015	13.55997	-0.00022	13.55999	-0.00007	13.55998	-0.00015
	6.375	13.55998	-0.00015	13.55997	-0.00022	13.55999	-0.00007	13.55998	-0.00015

Notes:

- The applicant declared that the normal operating temperature of the EUT is from -20°C to 60°C.

7.5 20 dB Bandwidth

Environmental Conditions:	25°C, 60% RH	Tested By:	Vincent Chen
---------------------------	--------------	------------	--------------

Channel	Channel Frequency (MHz)	20 dB Bandwidth (MHz)	Measured Frequencies		Operating Frequency Band (MHz)	Test Result
			FL (MHz)	FH (MHz)		
1	13.56	0.0255	13.5599	13.5473	13.11 ~ 14.01	Pass

Notes:

1. FL is the lowest frequency of the 20 dB bandwidth of power envelope.
2. FH is the highest frequency of the 20 dB bandwidth of power envelope.

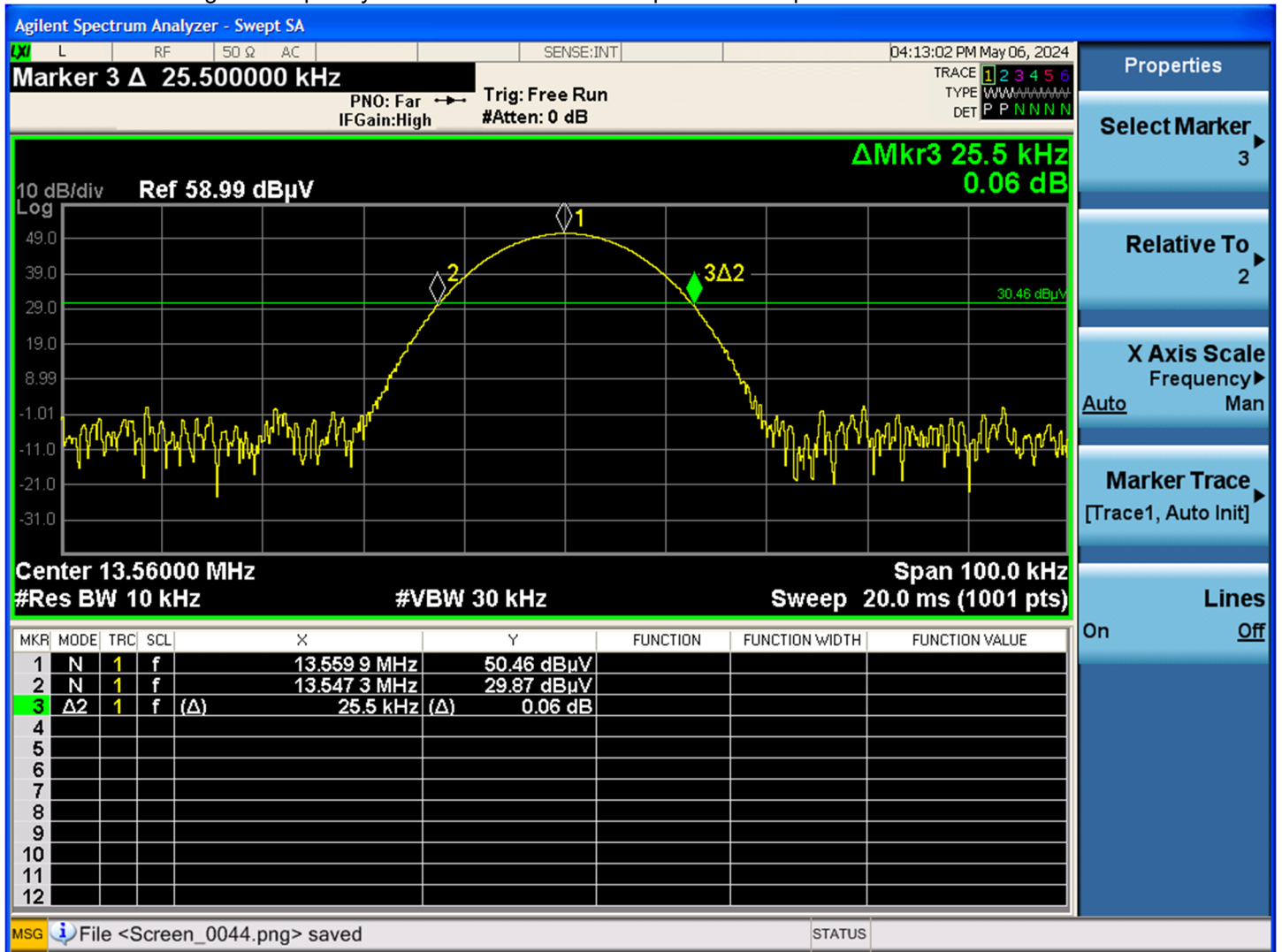

Note: The signal look like CW signal, so RBW can't be match 1~5 % OBW.

8 Pictures of Test Arrangements

Please refer to the attached file (Test Setup Photo)

9 Information of the Testing Laboratories

We, Bureau Veritas Consumer Products Services (H.K.) Ltd., Taoyuan Branch, were founded in 1988 to provide our best service in EMC, Radio, Telecom and Safety consultation. Our laboratories are FCC recognized accredited test firms and accredited according to ISO/IEC 17025.

If you have any comments, please feel free to contact us at the following:

Lin Kou EMC/RF Lab

Tel: 886-2-26052180

Fax: 886-2-26051924

Hsin Chu EMC/RF/Telecom Lab

Tel: 886-3-6668565

Fax: 886-3-6668323

Hwa Ya EMC/RF/Safety Lab

Tel: 886-3-3183232

Fax: 886-3-3270892

Email: service.adt@bureauveritas.com

Web Site: <http://ee.bureauveritas.com.tw>

The address and road map of all our labs can be found in our web site also.

--- END ---