

	    <p>CERTIFICATE 2518.08</p> <p>MS ISO/IEC 17025 TESTING SAMM NO. 0825</p>
---	---

<p>MOTOROLA PENANG ADV. COMM. LABORATORY Motorola Solutions Malaysia SDN BHD, Plot 2A, Medan Bayan Lepas, Mukim 12 S.W.D, 11900 Bayan Lepas, Penang, Malaysia.</p>	<p>FCC/IS ED TES T REPORT Report Revision : Rev.D</p>
---	---

<p>Date/s Tested : 26-JUL-2021 - 3-AUG-2021 Report Issue Date : 26-AUG-2021 Manufacturer : Motorola Solutions Malaysia SDN BHD Manufacturer Address : Plot 2A, Medan Bayan Lepas, Mukim 12 SWD, 11900 Bayan Lepas, Penang, Malaysia Requestor : SUBRAMANIAM VA SU Product Type : Hand-Held Product Version (PMN) : R7 Model Number (HVIN) : AAH06RDN9RA1AN (IC Model: PMUE5722ABB) Frequency Band : 400-527MHz Max RF Output Power : 4.8 Watts Applicant Name : Motorola Solutions Inc Applicant Address : 8000 West Sunrise Boulevard, Fort Lauderdale, Florida 33322</p> <p>IS ED Registrations : MY0001 FCC Registrations : 461337 Firmware Version (FVIN) : D02.21.04.0057</p>	
--	--

The equipment was tested accordance to the requirement listed below:

<p>(LMR) FCC 47 CFR Part 2/ 22 / 74 / 80 / 90 IS ED RSS- Gen Issue 5 / 119 Issue 12</p>	<p>PASS</p>
---	--------------------

This report shall not be reproduced without written approval from an off icially designated representative of the Motorola Penang Adv. Comm. Laboratory. The results and statements contained in this report pertain only to the dev ice(s) evaluated.



<p>Prepared By:</p> <div style="text-align: center;">  <hr style="width: 200px; margin: 0 auto;"/> <p>Putri Nur Sarah Sofia Test Personnel</p> </div>	<p>Approved Signatory:</p> <div style="text-align: center;">  <hr style="width: 200px; margin: 0 auto;"/> <p>Soon Oi May Responsible Engineer</p> </div>
--	---

Table of Contents

Report Revision History.....	3
1.0 General Information.....	4
2.0 Summary of Test Results	5
3.0 Measurement Uncertainty.....	6
4.0 Equipment List.....	7
5.0 Test Condition.....	10
5.1. Transmitter Test Conditions.....	10
6.0 Transmitter Test Parameters	11
6.1. RF Output Power	11
6.1.1. Test Setup.....	11
6.1.2. Test Result.....	11
6.2. Frequency Stability	12
6.2.1. Test Setup.....	12
6.2.2. Test Result.....	13
6.2.3. Test Limit.....	14
6.3. Audio Frequency Response.....	15
6.3.1. Test Setup.....	15
6.3.2. Test Result.....	16
6.3.3. Test Limit.....	19
6.4. Audio Low Pass Filter Response	20
6.4.1. Test Setup.....	20
6.4.2. Test Result.....	21
6.4.3. Test Limit.....	24
6.5. Modulation Limiting.....	25
6.5.1. Test Setup.....	25
6.5.2. Test Result.....	26
6.5.3. Test Limit.....	28
6.6. Occupied Bandwidth	29
6.6.1. Test Setup (Analog)	29
6.6.2. Test Result (Analog).....	30
6.6.3. Test Setup (Digital).....	39
6.6.4. Test Result (Digital).....	40
6.6.5. Test Limit.....	51
6.7. Band Edge Conducted Spurious Emission (Part 22)	52
6.7.1. Test Setup (Analog)	52
6.7.2. Test Result (Analog).....	53
6.7.3. Test Setup (Digital).....	54
6.7.4. Test Result (Digital).....	55
6.7.5. Test Limit.....	55
6.8. Transient Frequency Behavior	56
6.8.1. Test Setup.....	56
6.8.2. Test Result.....	57
6.8.3. Test Limit.....	59

6.9. Adjacent Channel Power 60

6.9.1. Test Setup (Analog) 60

6.9.2. Test Result..... 60

6.9.3. Test Setup (Digital)..... 61

6.9.4. Test Result..... 61

6.9.5. Test Limit..... 62

6.10. Conducted Spurious Emission 64

6.10.1. Test Setup..... 64

6.10.2. Test Result (Analog)..... 65

6.10.3. Test Result (Digital)..... 76

6.10.4. Test Limit..... 86

6.11. Radiated Spurious Emission 87

6.11.1. Test Setup..... 87

6.11.2. Test Result (Analog)..... 88

6.11.3. Test Result (Digital)..... 99

6.11.4. Test Limit..... 109

6.12. Effective Radiated Power (ERP) 110

6.12.1. Test Setup..... 110

6.12.2. Test Result..... 110

6.12.3. Test Limit..... 110

6.13. GNSS (EIRP for 1559 - 1610MHz) 111

6.13.1. Test Setup..... 111

6.13.1. Test Result..... 112

6.13.2. Test Limit..... 112

Report Revision History

Revision History	Description	Date	Originator
Rev. A	Initial Report	3-AUG-2021	Putri Nur Sarah Sofia
Rev. B	Additional note in OBW	8-Sep-2021	Putri Nur Sarah Sofia
Rev. C	Added the FXD and FXE in section 2.0 table of summary result .	20-Sep-2021	Putri Nur Sarah Sofia
Rev. D	Update worst case emission margin.	30-Sep-2021	Putri Nur Sarah Sofia

1.0 General Information

EUT Description:

Technologies	Land Mobile Radio (LMR)
Modulation Type	Analog, 4FSK

The EUT contains following accessory devices and data cable:

Item	Brand	Model or P/N
BATTERY PACK,BATT IMPRES LIION TIA4950 IP68 3200T	MOTOROLA	PMNN4810A

General Description of Applied Standards

The EUT is a RF Product. According to the specifications of the manufacturer, the EUT is to comply with the requirements of the following standards:

ANSI C63.26-2015

No modifications were done to the UUT to facilitate the tests in this report.

Deviation from standard

Not applicable as no deviation from standard test method

Antenna gain disclaimer

Antenna gain information is provided by customer. The validity of the results is dependent upon this information. The lab will not be held accountable in the event the supplied information affects compliance.

Test configuration of EUT

All relevant configurations involving radio models and accessories (including chargers, batteries, and antennas) were assessed. Only worst case configurations will be included in this report.

2.0 Summary of Test Results

FCC General Rules Part (47CFR)	ISED General Rules Part	Test Item	Result	Remarks	Serial number tested
Part 80, Part 90	RSS-119	RF Power Output	Pass		P4N0XP0VGP
2.1055, 90.213, 22.355, 74.464, 74.561	RSS-119	Frequency Stability	Pass		P4N0XP0VGP
2.1047, 74.463, 80.213	RSS-119	Audio Frequency Response	Pass		P4N0XP0VGP
2.1047, 74.463, 80.213	RSS-119	Audio Low Pass Filter Response	Pass		P4N0XP0VGP
2.1047, 74.463, 80.213	RSS-119	Modulation limiting	Pass		P4N0XP0VGP
2.1049, 90.210, 22.359, 74.462, 74.535, 80.211(c), 80.211 (f)	RSS-119	Occupied Bandwidth	Pass	16K0F3E – 15.0151kHz 11K0F3E – 9.8711kHz 7K60F1D/7K60FXD – 7.5015kHz 7K60F1E/7K60FXE – 6.9774kHz 7K60F1W – 7.2646kHz	P4N0XP0VGP
22.359 (a), (b)	RSS-119	Band Edge Conducted Spurious Emission	Pass		P4N0XP0VGP
90.214	RSS-119	Transient Frequency Behavior	Pass		P4N0XP0VGP
-	-	Adjacent Channel Power	NA		
2.1051, 22.359, 90.210, 74.462(c), 80.211(c)	RSS-119	Conducted Spurious Emissions	Pass	Worst case emission - -29.09dBm	P4N0XP0VGP
2.1051, 22.359, 90.210, 74.462(c), 80.211(c)	RSS-119	Radiated Spurious Emission	Pass	Worst case emission - -52.4400dBm (Margin- -32.44dB)	865TXP0010
-	-	GNSS (EIRP for 1559 – 1610MHz)	NA		
80.215(e)	-	Effective Radiated Power (ERP)	Pass		

NA → Not Applicable

3.0 Measurement Uncertainty

Measurement	Frequency	Expanded Uncertainty (k=1.96) (±)
AC Power Line Conducted Spurious Emission	150KHz ~ 30MHz	3.48 dB
Radiated Emissions up to 1 GHz	30MHz ~ 1000MHz	5.88 dB
Radiated Emissions above 1 GHz	1GHz ~ 18GHz	5.84 dB
	18GHz ~ 40GHz	6.02 dB
Radiated Emissions dBm (ERP/EiRP)	30MHz ~ 18GHz	4.03dB
Conducted Spurious Emissions	9kHz ~ 12.75GHz	2.82 dB
Frequency Stability	9kHz ~ 12.75GHz	0.0085 ppm
Audio Frequency Response / Low Pass Filter Response	300Hz – 20kHz	4.09 %
Modulation Limiting	300Hz – 3kHz	1.15 %
Occupied Bandwidth	9kHz ~ 12.75GHz	2.82 dB
Band Edge Conducted Spurious Emission	9kHz ~ 12.75GHz	2.82 dB
Transient Frequency Behavior	9kHz ~ 12.75GHz	5.4 ms
Adjacent Channel Power	9kHz ~ 12.75GHz	2.82 dB

4.0 Equipment List

FCC Analog ATE#1: (SW version: 2.4.6 & FCC_Frequency Stability 1.0.3 rev.)

Description	Model	Serial Number	Calibration Date	Calibration Due Date
CHAMBER	SH-641	92009188	08-Mar-21	08-Mar-22
SWITCH CONTROL SYSTEM	3499B	CN40150337	CNR	CNR
AUDIO ANALYZER	8903B	3514A15797	28-Oct-20	28-Oct-21
POWER SENSOR	E4412A	MY50290007	15-Dec-20	15-Dec-21
MODULATION ANALYZER	8901B	3216A03949	14-Nov-20	14-Nov-21
POWER SUPPLY	6032A	3232A08203	14-Jun-21	14-Jun-22
ANALYZER SIGNAL	35670A	MY42506790	29-Oct-20	29-Oct-21
POWER METER	E4416A	GB41293240	14-Mar-21	14-Mar-22
N to N RF Cable # 1	M17/128-RG400	NA	NA	NA
BNC to N RF Cable # 1	RG 58	NA	NA	NA
BNC to BNC RF Cable # 1	RG 58	NA	NA	NA
BNC to BNC RF Cable # 2	RG 58	NA	NA	NA
BNC to BNC RF Cable # 3	RG 58	NA	NA	NA
BNC to BNC RF Cable # 4	RG 58	NA	NA	NA
BNC to BNC RF Cable # 5	RG 58	NA	NA	NA
BNC to BNC RF Cable # 6	RG 58	NA	NA	NA
BNC to BNC RF Cable # 7	RG 58	NA	NA	NA
N to SMA RF Cable # 1	RG 58	NA	NA	NA
N to SMA RF Cable # 2	RG 58	NA	NA	NA
N to SMA RF Cable # 3	RG 58	NA	NA	NA
Aeroflex Attenuator 30dB	49-30-34-LIM	NA	NA	NA

FCC Transient ATE #1: (SW version: FCC Transient ATE_R1.1.3)

Description	Model	Serial Number	Calibration Date	Calibration Due Date
SWITCH CONTROL UNIT	3488A	2719A36210	CNR	CNR
ATTENUATOR / SWITCH DRIVER	11713A	2508A10141	CNR	CNR
STEP ATTENUATOR	8496G	MY42143970	26-Sep-20	26-Sep-21
POWER SENSOR	E9301B	MY41495393	15-May-21	15-May-22
SIGNAL GENERATOR	8657A	3039A02769	11-Jun-21	11-Jun-22
MODULATION ANALYZER	8901B	2920A02173	10-Nov-20	10-Nov-21
AUDIO ANALYZER	8903B	3011A10318	28-Oct-20	28-Oct-21
POWER METER	E4418B	MY45104923	20-Feb-21	20-Feb-22
OSCILLOSCOPE	MSO8064A	MY45003003	06-Nov-20	06-Nov-21
AUDIO ANALYZER	8903B	2614A01237	16-Apr-21	16-Apr-22
STEP ATTENUATOR	8494G	MY52300967	17-Jun-21	17-Jun-22
POWER SUPPLY	6033A	3004A04987	08-Jul-21	08-Jul-22
ANALYZER SPECTRUM	E4445A	MY46181732	29-Jun-21	29-Jun-22
N to N RF Cable # 1	SF126/11N/11N	NA	NA	NA
N to N RF Cable # 1	SF126/11N/11N	NA	NA	NA
N to N RF Cable # 2	M17/128-RG400	NA	NA	NA
N to N RF Cable # 3	M17/128-RG400	NA	NA	NA
N to N RF Cable # 4	M17/128-RG400	NA	NA	NA
N to N RF Cable # 5	M17/128-RG400	NA	NA	NA
N to N RF Cable # 6	M17/128-RG400	NA	NA	NA
N to N RF Cable # 7	M17/128-RG400	NA	NA	NA
N to N RF Cable # 8	M17/128-RG400	NA	NA	NA
N to N RF Cable # 9	M17/128-RG400	NA	NA	NA
BNC to BNC RF Cable # 1	RG 58	NA	NA	NA
BNC to BNC RF Cable # 2	RG 58	NA	NA	NA
BNC to BNC RF Cable # 3	RG 58	NA	NA	NA
BNC to BNC RF Cable # 4	RG 58	NA	NA	NA
BNC to BNC RF Cable # 5	RG 58	NA	NA	NA
BNC to BNC RF Cable # 6	RG 58	NA	NA	NA
BNC to N RF Cable # 1	RG 58	NA	NA	NA
Aeroflex Attenuator 10d B	49-10-43-LIM	NA	NA	NA
Aeroflex Attenuator 10d B	33-10-34-LIM	NA	NA	NA

FCC CONDUCTED SPUR EMISSION ATE # 1 (SW version: Conducted Spur ATE_rev 1.23.03)

Description	Model	Serial Number	Calibration Date	Calibration Due Date
SWITCH CONTROL UNIT	3488A	2719A32735	CNR	CNR
ANALYZER SPECTRUM	E4440A	MY46185415	10-Jan-20	10-Jan-22
POWER SUPPLY	6031A	3221A02613	25-May-21	25-May-22
INTERFACE BOX - FILTER	CNR	CS001	06-Jul-21	06-Jul-22
N to N RF Cable # 1	SF126/11N/11N	NA	NA	NA
N to N RF Cable # 2	SF126/11N/11N	NA	NA	NA
BNC to BNC RF Cable # 1	RG 58	NA	NA	NA
Aeroflex Attenuator 30d B	49-30-43-LIM	NA	NA	NA
Aeroflex Attenuator 10d B	33-10-34-LIM	NA	NA	NA

EMC Chamber 1

DESCRIPTION	MODEL	SERIAL NUMBER	CALIBRATION DATE	CALIBRATION DUE DATE
DRG HORN FREQ.	SAS-571	719	20-Aug-19	20-Aug-21
DRG HORN FREQ.	SAS-571	566	22-Oct-19	22-Oct-21
POWER SUPPLY	N7976A	MY53410110	24-May-21	24-May-22
SIGNAL GENERATOR	SMB 100A	181117	8-Nov-18	8-Nov-21
EMI TEST RECEIVER	ESW44	101750	15-Jan-21	15-Jan-22
EMI TEST RECEIVER	ESIB26	827769/009	11-Mar-21	11-Mar-22
5m SEMI-ANECHOIC CHAMBER	S800-HX	J2308	CNR	CNR
BILOG ANTENNA	CBL6112B	30991	20-Aug-20	20-Aug-21
BILOG ANTENNA	CBL6112B	2964	4-May-21	4-May-22
HYGRO-THERMOMETER	SDL500	A.016800	18-May-21	18-May-22
SYSTEM CONTROLLER	SC104V	050806-1	CNR	CNR
TURNTABLE FLUSH MOUNT 2M	FM2011	NA	CNR	CNR
ANTENNA POSITIONING TOWER	TLT2	NA	CNR	CNR
BROAD-BAND HORN ANTENNA	BBHA 9170	BBHA 9170255	4-Feb-21	4-Feb-22
18 - 40GHz PREAMPLIFIER	MITEQ Hi GA IN SUCOFLEX	2006313	CNR	CNR
PREAMPLIFIER	PAM-0118P	361	11-Sep-20	11-Sep-23
LOOP ANTENNA	6502	00208416	15-Sep-20	15-Sep-21
TEST SOFTWARE	EMC_FCC_IC_BLUETOOTH_RE_TEST			
VERSION	EMC_FCC_RE_v1.6.2			

5.0 Test Condition

5.1. Transmitter Test Conditions

Test Item, (Channel S pacing)	Power (W)	Modulation	Test Frequency (MHz)	Tested By	Environmental conditions
RF Output Power	Low & Max	Analog	400.0125, 406.2, 450.025, 459.125, 467.775, 469.9875, 482.0125, 511.9875, 526.9875	Putri	23.4°C, 50% RH
Frequency Stability	Max	Analog	467.775	Putri	25.1°C, 54.3% RH, 60.3°C, 50% RH, -30.1°C, 51.2% RH
Audio Frequency Response (12.5kHz / 25kHz)	Max	Analog	459.125, 467.775, 511.9875	Putri	23.4°C, 50% RH
Audio Low Pass Filter Response (12.5kHz / 25kHz)	Max	Analog	459.125, 467.775, 511.9875	Putri	23.4°C, 50% RH
Modulation limiting (12.5kHz / 25kHz)	Max	Analog	459.125, 467.775, 511.9875	Putri	23.4°C, 50% RH
Occupied Bandwidth (12.5kHz / 20kHz / 25kHz)	Max	Analog, 4FS K	400.0125, 406.2, 450.025, 459.125, 467.775, 469.9875, 473.0125, 482.0125, 511.9875, 526.9875	Putri	23.4°C, 50% RH
Band Edge Conducted Spurious Emissions (Part 22) (12.5kHz / 20kHz / 25kHz)	Max	Analog, 4FS K	459.025, 459.65, 473.0125, 479.2875	Putri	23.4°C, 50% RH
Transient Frequency Behavior (UHF & VHF Band) (12.5kHz / 25kHz)	Max	Analog, 4FS K	467.775	Putri	23.4°C, 50% RH
Adjacent Channel Power (700MHz Band) (12.5kHz / 25kHz)	Max	Analog, 4FS K	NA	NA	NA
Conducted Spurious Emissions- (12.5kHz / 25kHz)	Low / Max	Analog, 4FS K	400.0125, 406.2, 450.025, 459.125, 467.775, 482.0125, 511.9875, 526.9875	Putri	23.4°C, 50% RH
Radiated Spurious Emission (12.5kHz / 25kHz)	Low / Max	Analog, 4FS K	400.0125, 406.2, 450.025, 459.125, 467.775, 482.0125, 511.9875, 526.9875	Qawi man & Nazrin	24.1°C, 70.1% RH
GNSS (EIRP for 1559 - 1610MHz) (12.5kHz / 25kHz)	Max	Analog	NA	NA	NA
Effective Radiated Power (ERP) (12.5kHz / 25kHz)	Max	Analog	467.775	NA	NA

6.0 Transmitter Test Parameters

6.1 RF Output Power

6.1.1 Test Setup

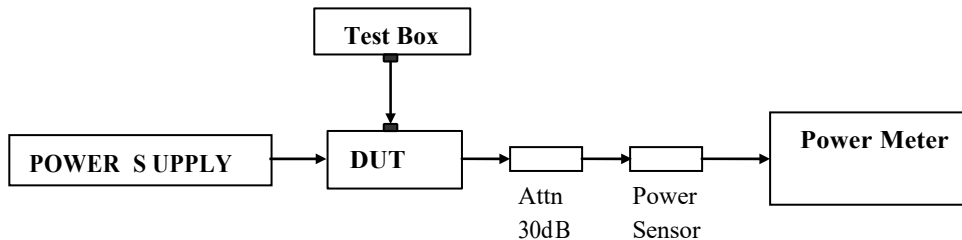

- 1) The DUT transmitter connected to Power Meter using the 30 dB attenuator and power sensor with above setup.
- 2) Path loss for the measurement included.
- 3) All the measurement was done at low, mid, high frequency for each band.
- 4) Record the power into the test report.

6.1.2 Test Result

Temperature	25°C				Remark
Voltage (V)	7.5V				
Frequency (MHz)	Low Power (W)	Current (A)	Max Power (W)	Current (A)	
400.01250	0.99	0.83	4.68	1.61	Not for FCC review
406.20000	1.05	0.80	4.75	1.53	
450.02500	0.97	0.78	4.68	1.62	
459.12500	0.95	0.80	4.65	1.64	
467.77500	0.94	0.80	1.96	1.01	Part 80 (2W)
469.98750	0.94	0.80	4.65	1.64	
482.01250	0.95	0.78	4.68	1.61	
511.98750	1.03	0.77	4.74	1.55	
526.98750	1.02	0.80	4.74	1.68	Not for FCC review

6.2. Frequency Stability

6.2.1. Test Setup

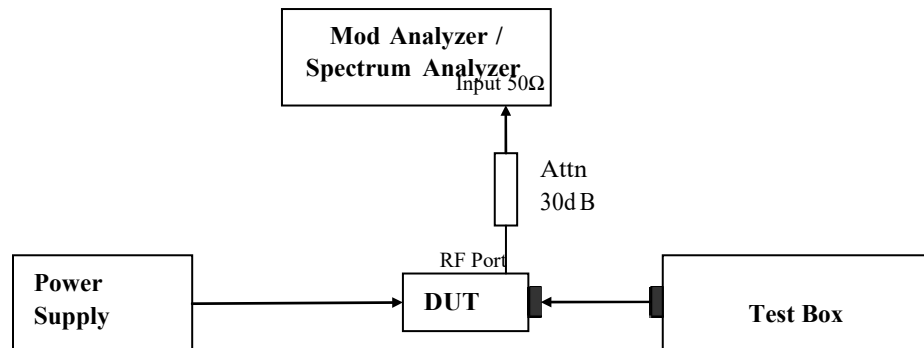

- 1) The DUT transmitter output port was connected to Modulation / Spectrum Analyzer.
- 2) Path loss for the measurement included.
- 3) Transmit the DUT and record the freq in MCF_{MHz} .
- 4) Test in 2 conditions:
 - Temperature: The frequency of the transmitter was measured from $-30^{\circ}C$ to $50^{\circ}C$.
 - Supply Voltage:
 - Mobile: The frequency of the transmitter was measured from 85% to 115% of the nominal operating input voltage.
 - Portable: The frequency of the transmitter was measured from nominal $\pm x\%$ as specified by the manufacturer
- 5) Calculate the ppm frequency error by the following:

$$ppm\ error = \left(\frac{MCF_{MHz}}{ACF_{MHz}} - 1 \right) * 10^6$$

Where: MCF_{MHz} is the Measured Carrier Frequency in MHz
 ACF_{MHz} is the Assigned Carrier Frequency in MHz

6.2.2. Test Result

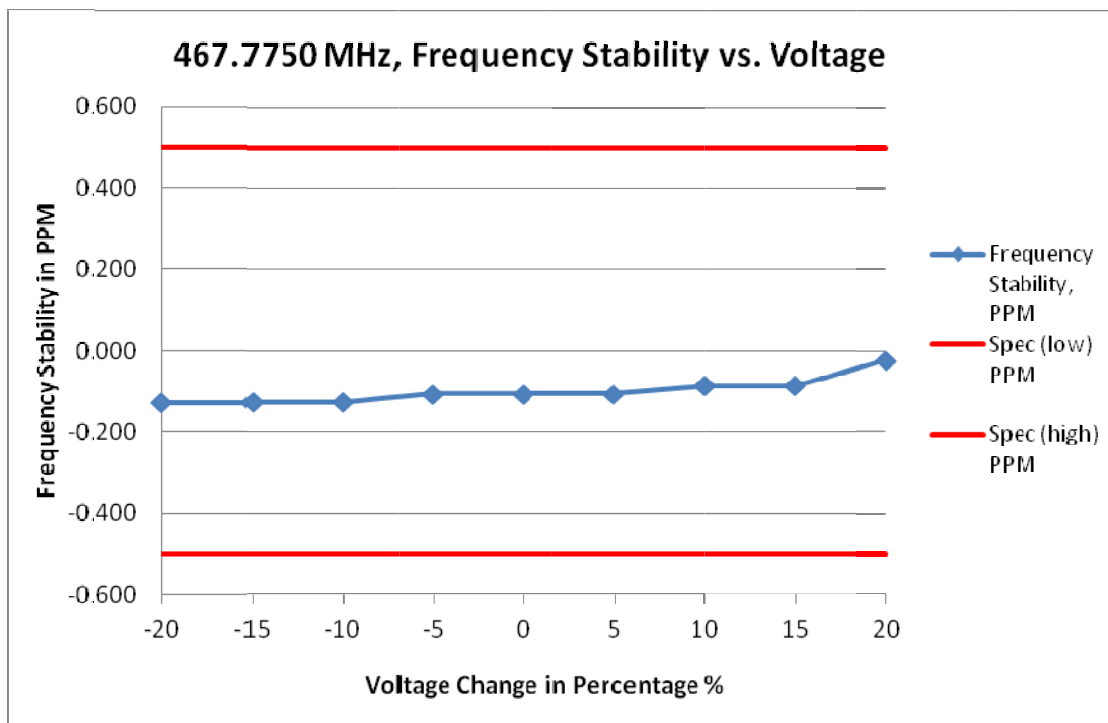

(i) Frequency Stability VS Voltage

Frequency / Channel Spacing	467.7750 MHz / 12.5 kHz				
Temperature, °C	25				
Voltage %	Voltage, V	Frequency, MHz	Frequency Stability, PPM	Spec (low) PPM	Spec (high) PPM
-20	6.000	467.774940	-0.128	-0.500	0.500
-15	6.375	467.774940	-0.128	-0.500	0.500
-10	6.750	467.774940	-0.128	-0.500	0.500
-5	7.120	467.774950	-0.107	-0.500	0.500
0	7.500	467.774950	-0.107	-0.500	0.500
5	7.870	467.774950	-0.107	-0.500	0.500
10	8.250	467.774960	-0.086	-0.500	0.500
15	8.625	467.774960	-0.086	-0.500	0.500
20	9.000	467.774990	-0.021	-0.500	0.500

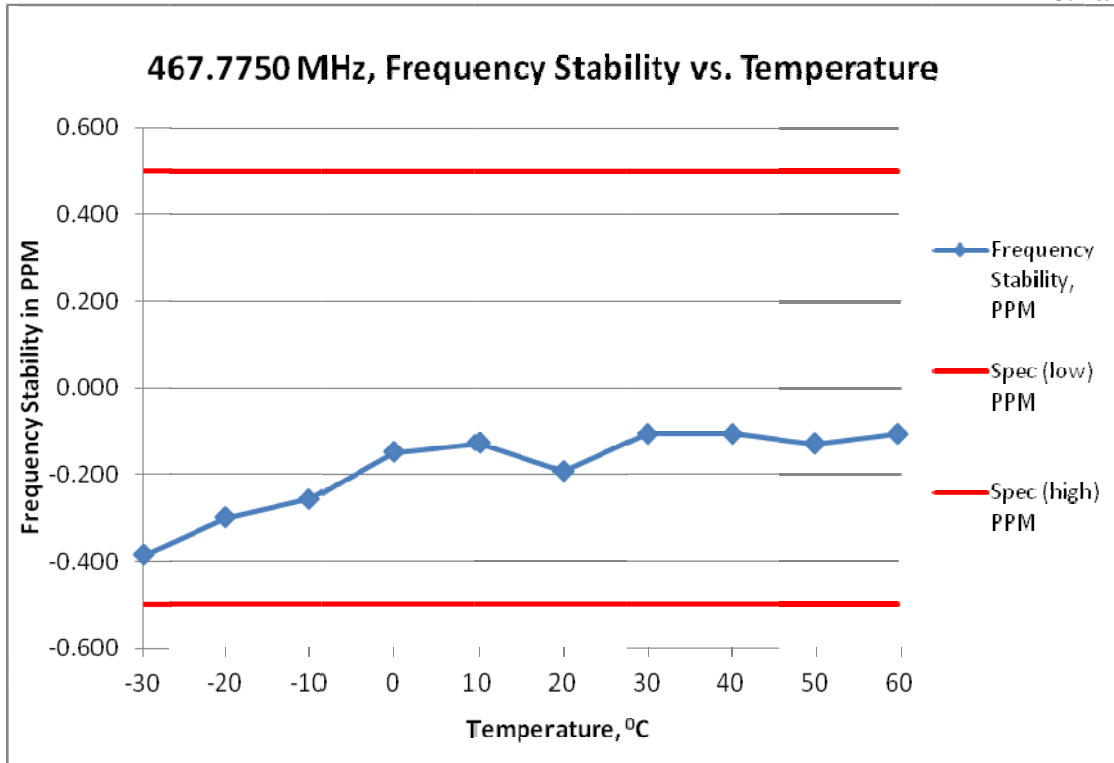

(ii) Frequency Stability VS temperature

Frequency / Channel Spacing	467.7750 MHz / 12.5 kHz			
Voltage, V	7.5			
Temperature, °C	Frequency, MHz	Frequency Stability, PPM	Spec (low) PPM	Spec (high) PPM
-30	467.774820	-0.385	-0.500	0.500
-20	467.774860	-0.299	-0.500	0.500
-10	467.774880	-0.257	-0.500	0.500
0	467.774930	-0.150	-0.500	0.500
10	467.774940	-0.128	-0.500	0.500
20	467.774910	-0.192	-0.500	0.500
30	467.774950	-0.107	-0.500	0.500
40	467.774950	-0.107	-0.500	0.500
50	467.774940	-0.128	-0.500	0.500
60	467.774950	-0.107	-0.500	0.500

6.2.3. Test Limit

As per manufacturer declared spec +/- 0.5ppm

6.3. Audio Frequency Response

6.3.1. Test Setup

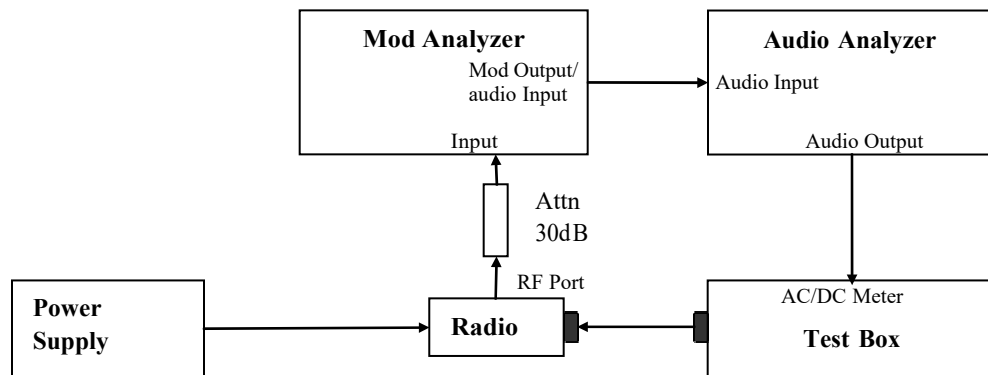

- 1) The DUT transmitter output port was connected to Modulation Analyzer.
- 2) Path loss for the measurement included.
- 3) Set the audio bandwidth filter to 15 kHz and 50 kHz.
- 4) Transmit the radio and set the audio analyzer to 1 kHz audio frequency and 20% of the Full rated system deviation.
- 5) On audio analyzer, set the rated level as reference to zero.
- 6) Vary the audio frequency from 300 Hz to 3 kHz. Record the change in dB on the audio analyzer.

6.3.2. Test Result

Not for FCC review

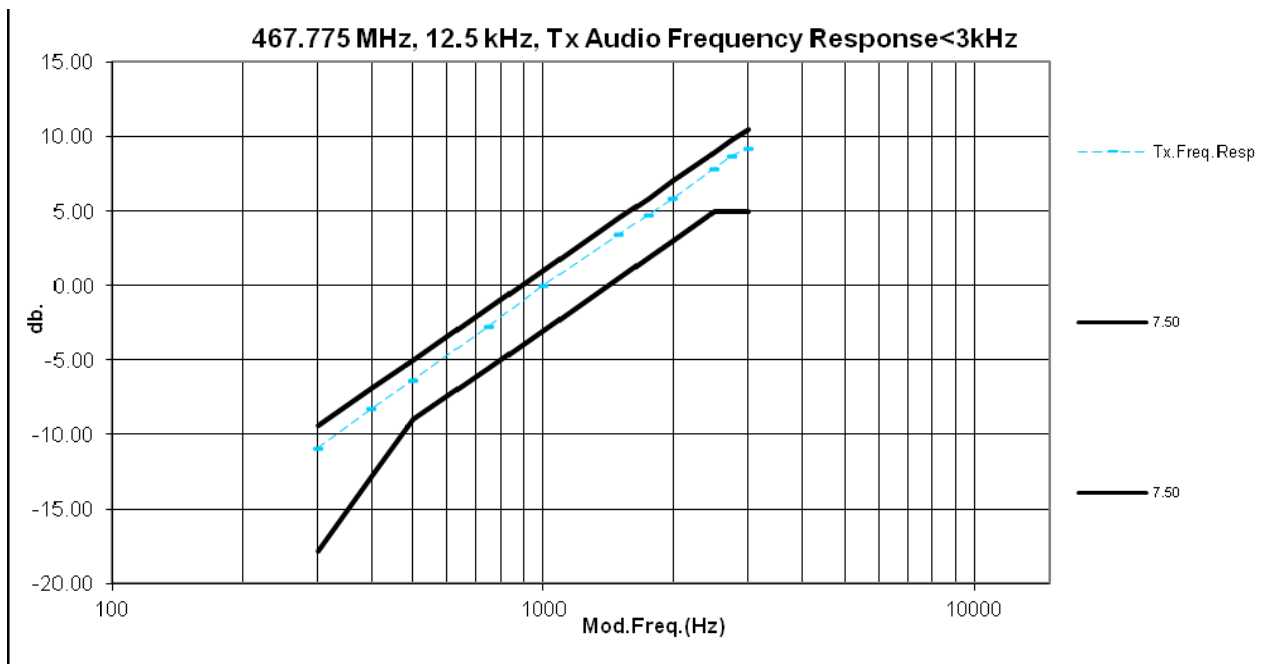
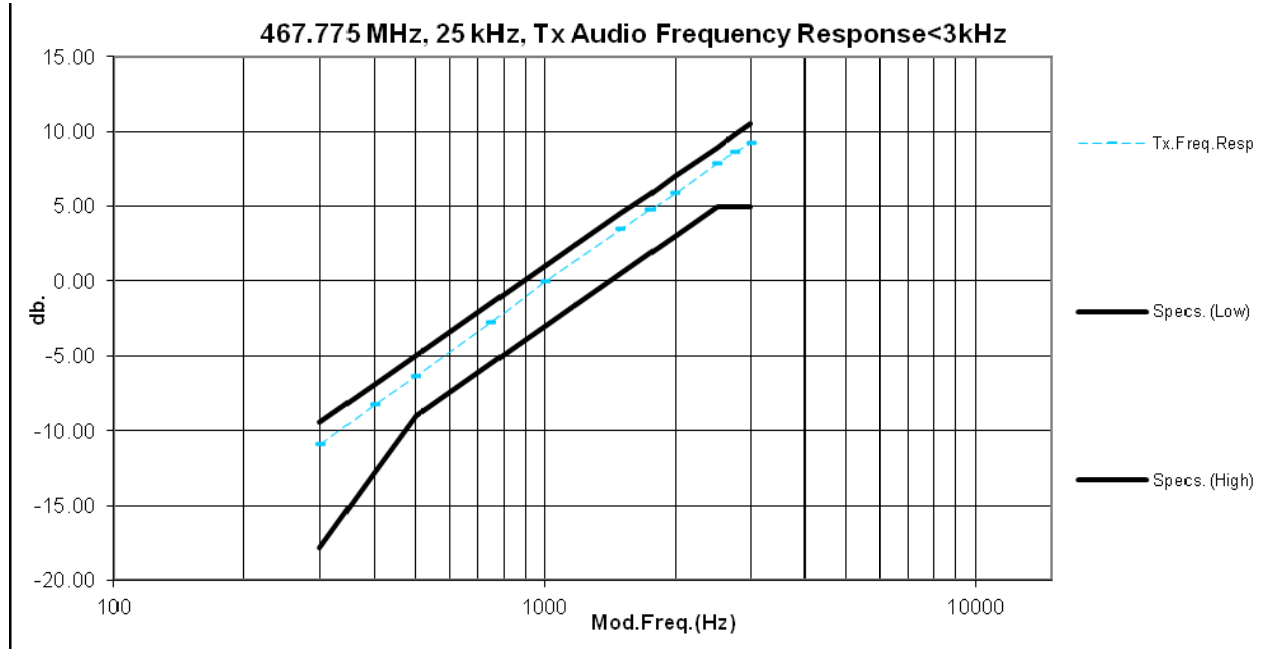

Not for FCC review

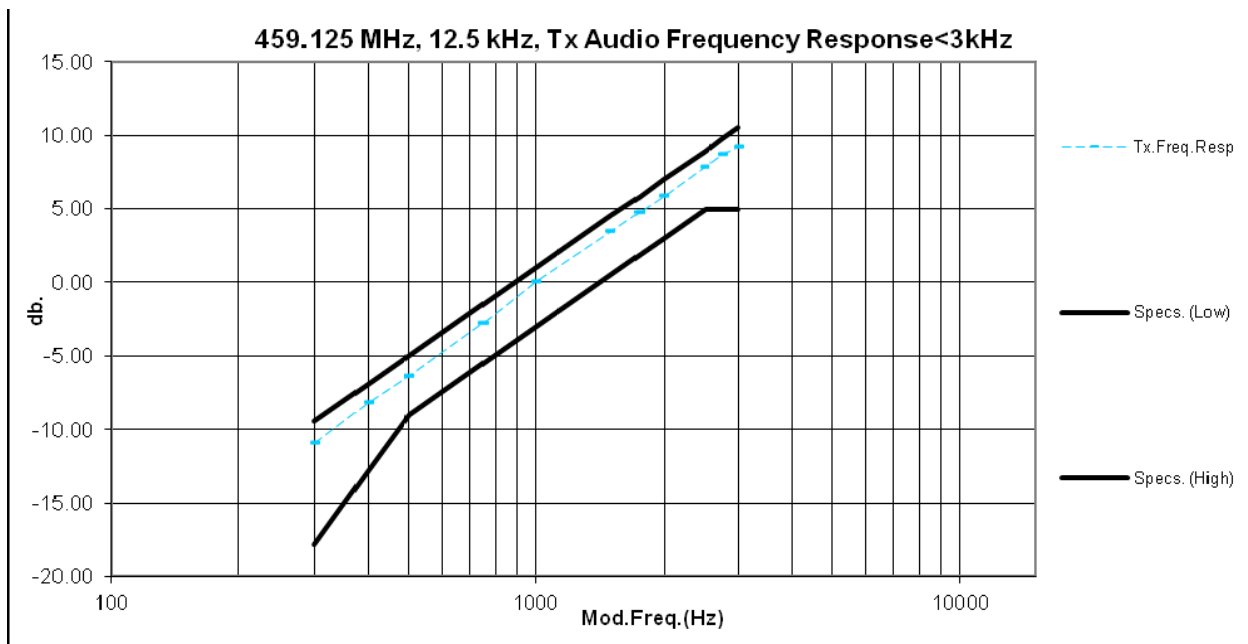
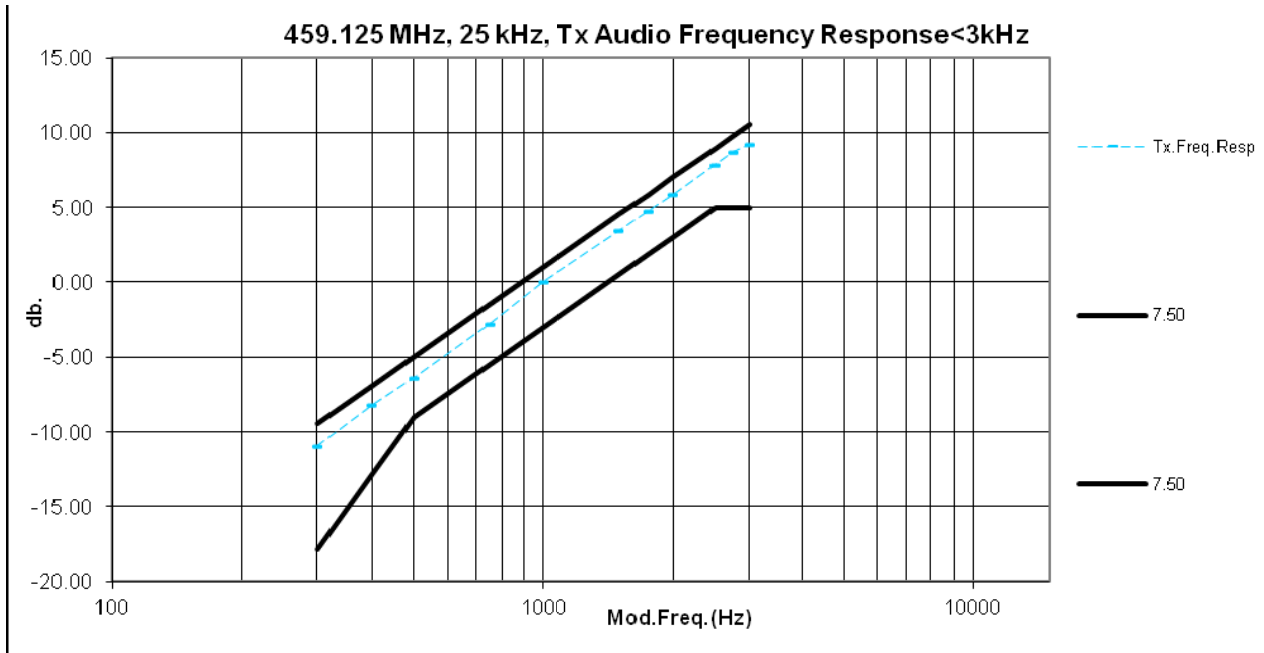

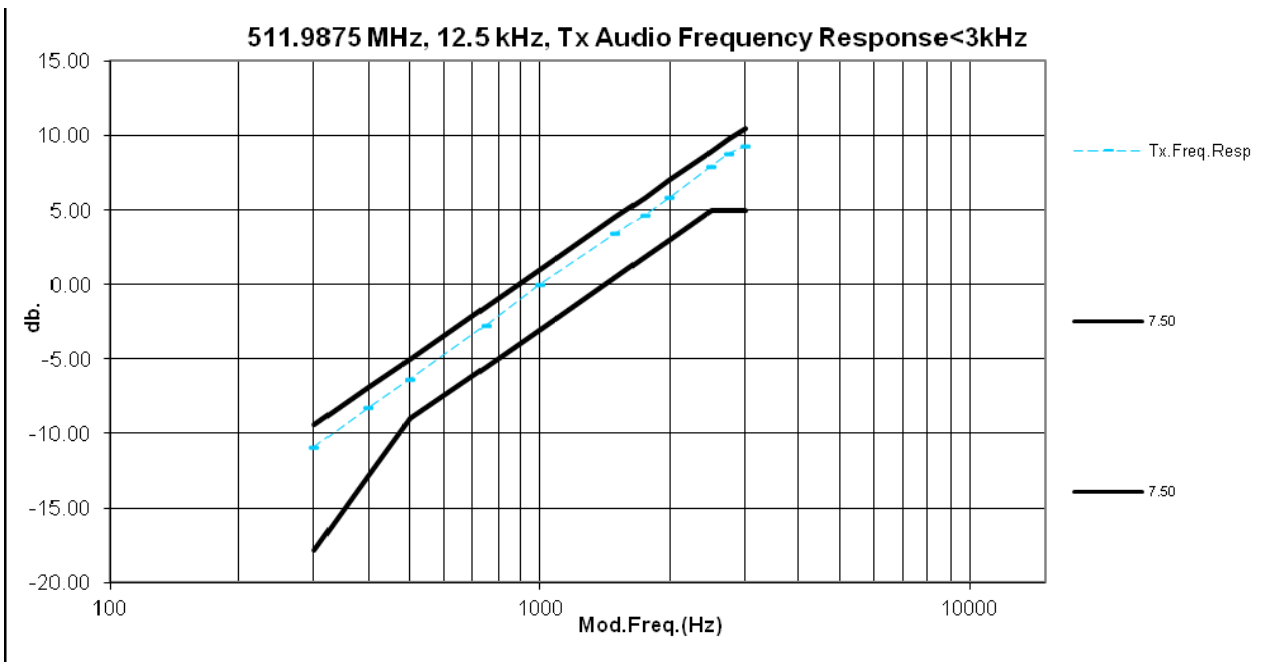
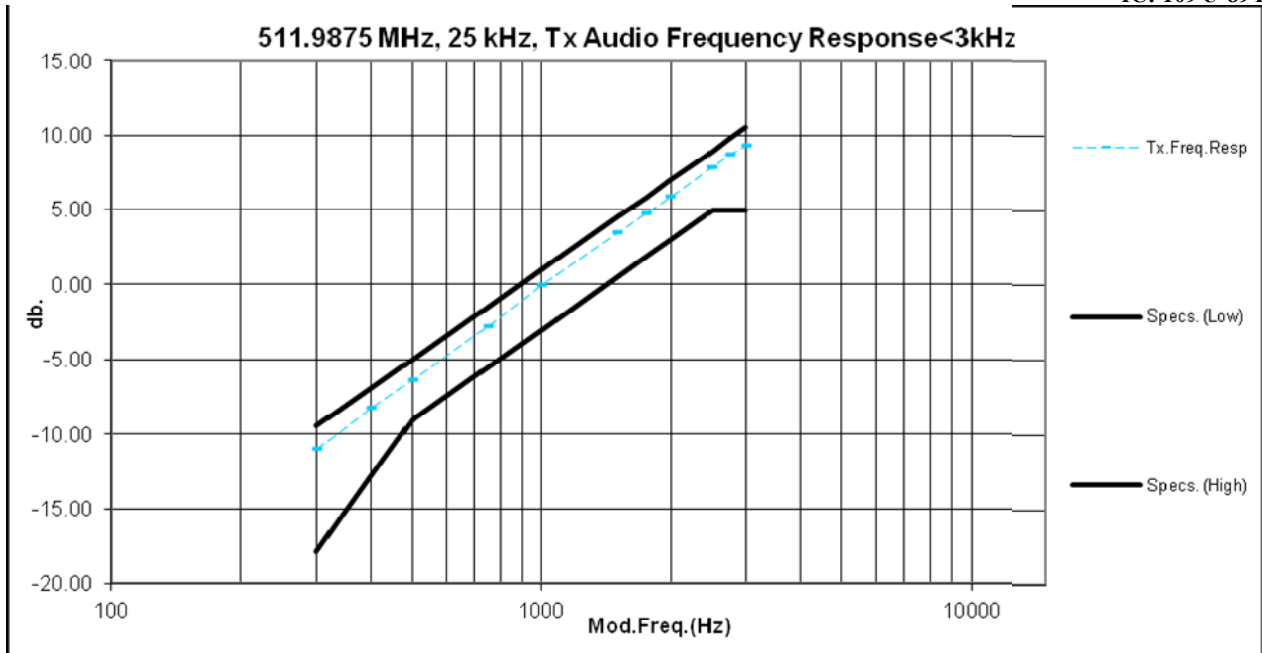

6.3.3. Test Limit

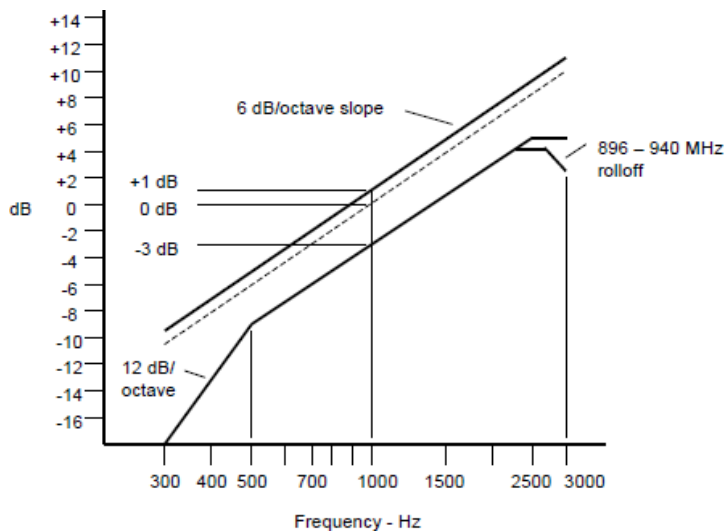

Note:

- o There are additional 6 dB per octave attenuation is allowed from 2.5 KHz to 3KHz in equipment 25MHz to 869MHz radio.
- o Additional 6 dB per octave attenuation is allowed from 2.3 KHz to 2.7KHz & additional 12 dB per octave attenuation is allowed from 2.7KHz to 3KHz in equipment 896MHz to 940MHz radio.

6.4. Audio Low Pass Filter Response

6.4.1. Test Setup

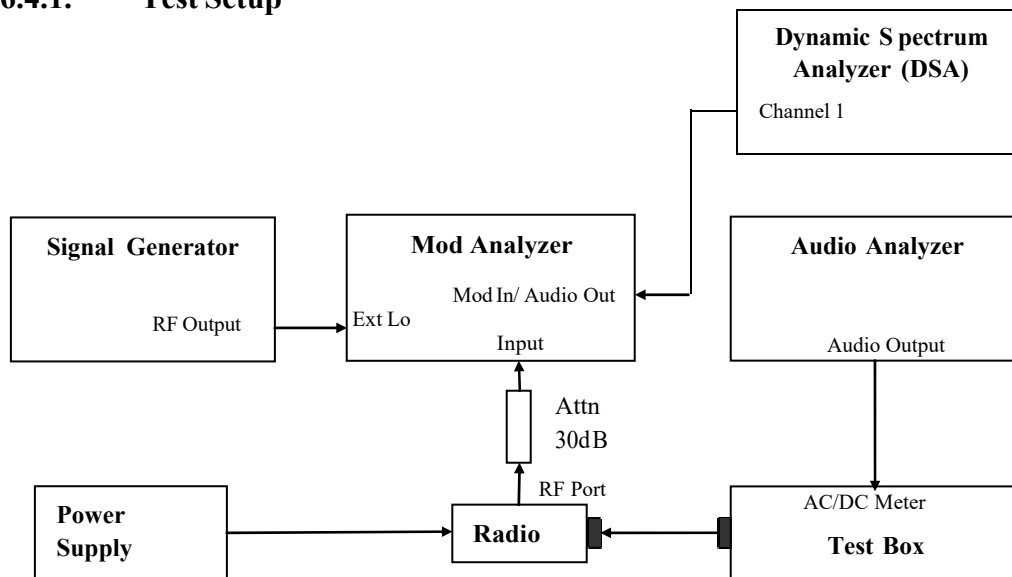

- 1) The DUT transmitter output port was connected to Modulation Analyzer.
- 2) Path loss for the measurement included.
- 3) Press 23.1SPCL on modulation analyzer to enable the external LO from Sigen.
- 4) Set the Sigen frequency to $F_c + 1.5$ MHz, RF output level to 0dBm without modulation.
- 5) Transmit the radio and set the audio analyzer to 1 kHz audio frequency and 60% of the Full rated system deviation.
- 6) Up the amplitude by 20dB.
- 7) On DSA, get the reference point to 0dB.
- 8) Vary the frequency on audio analyzer from 3 kHz to 20 kHz, record the audio tone from DSA.

6.4.2. Test Result

Not for FCC review

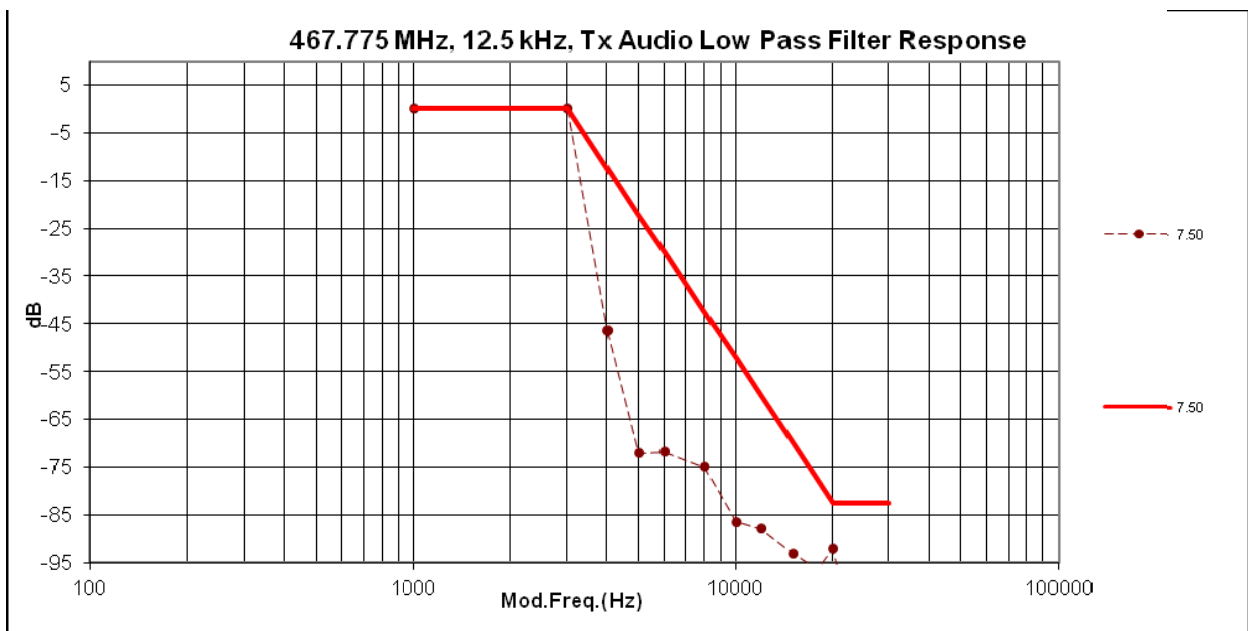
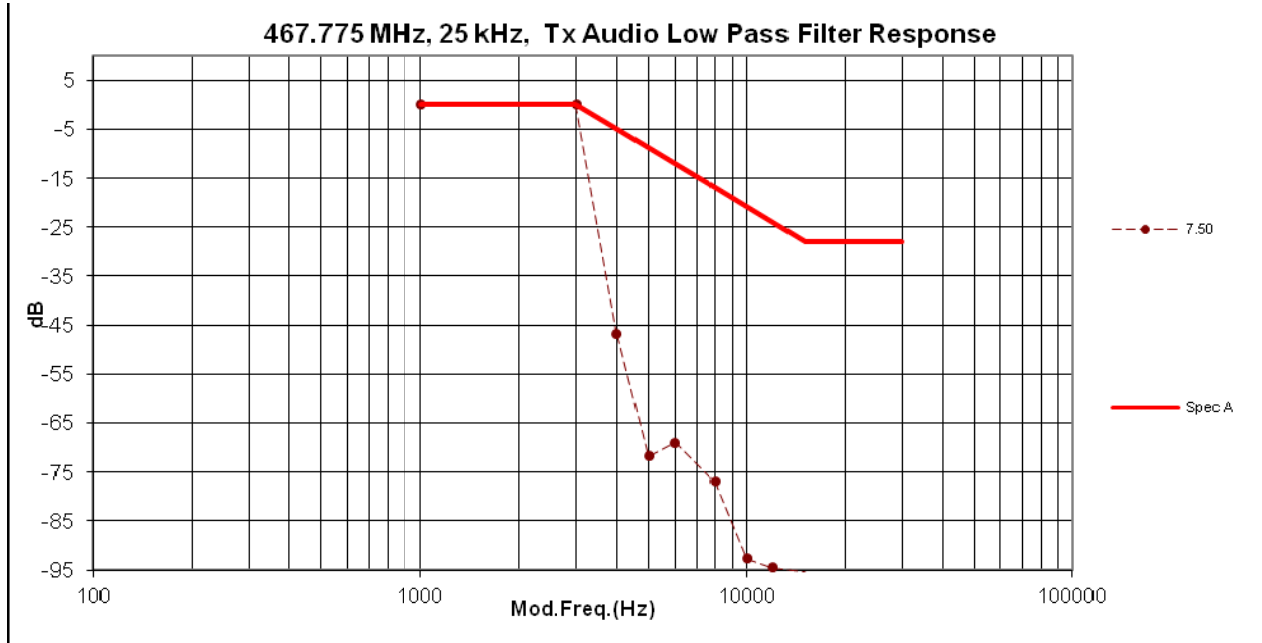

Not for FCC review

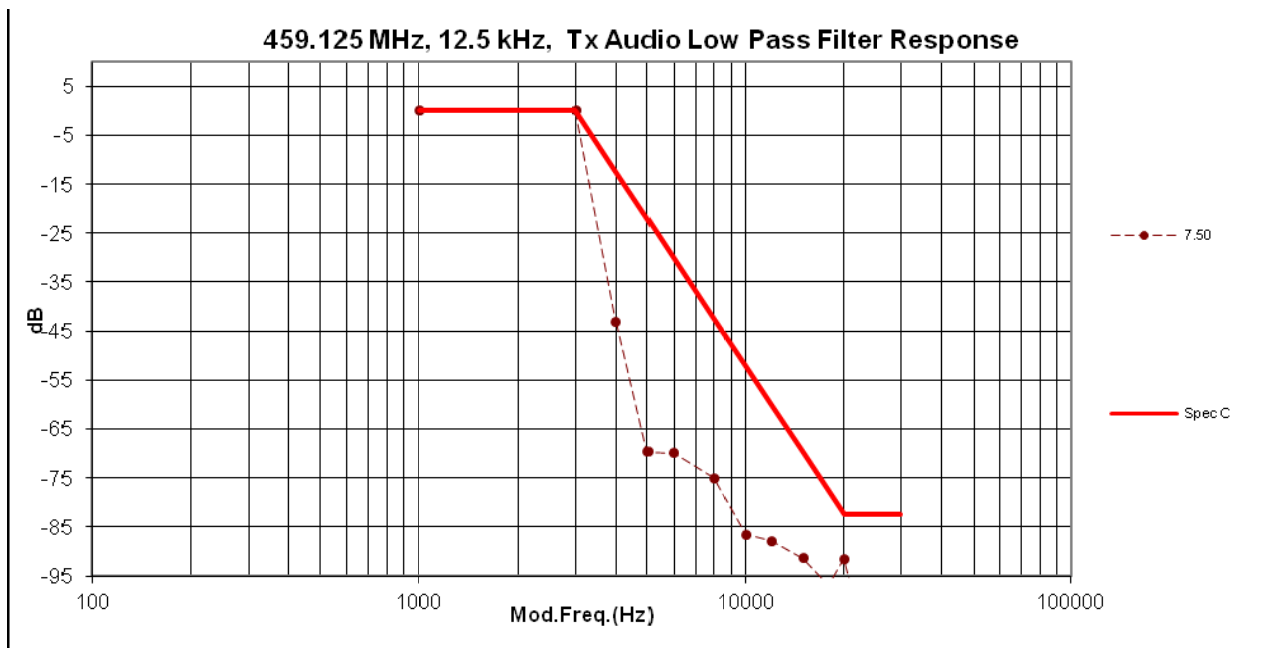
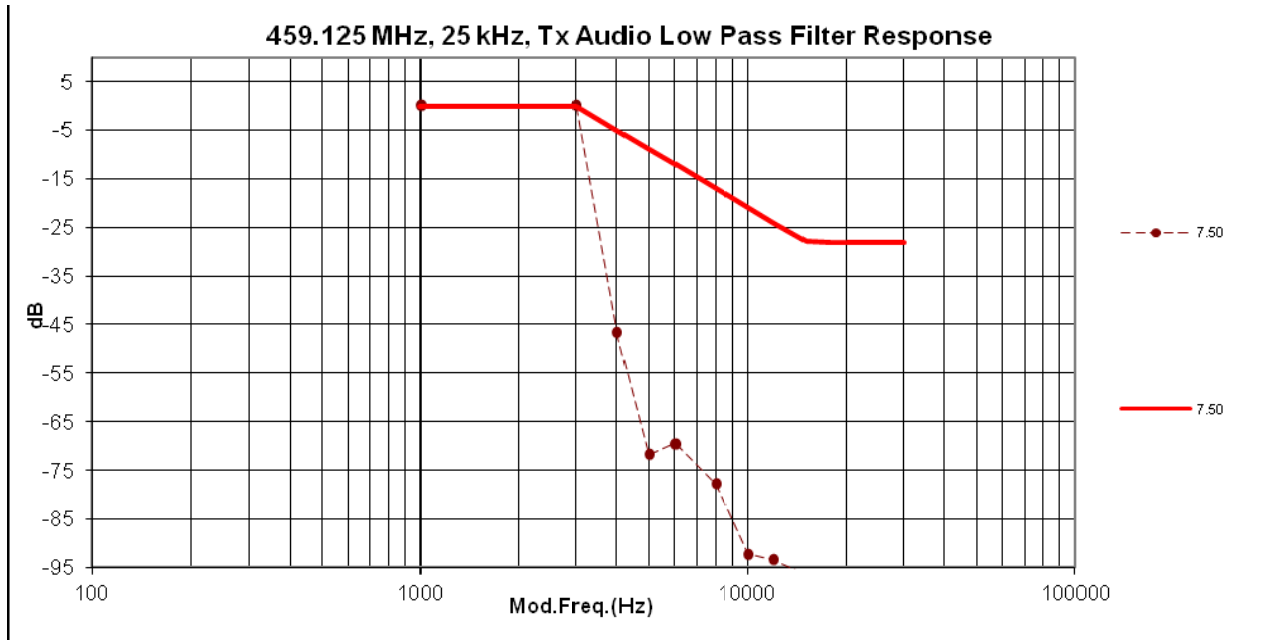

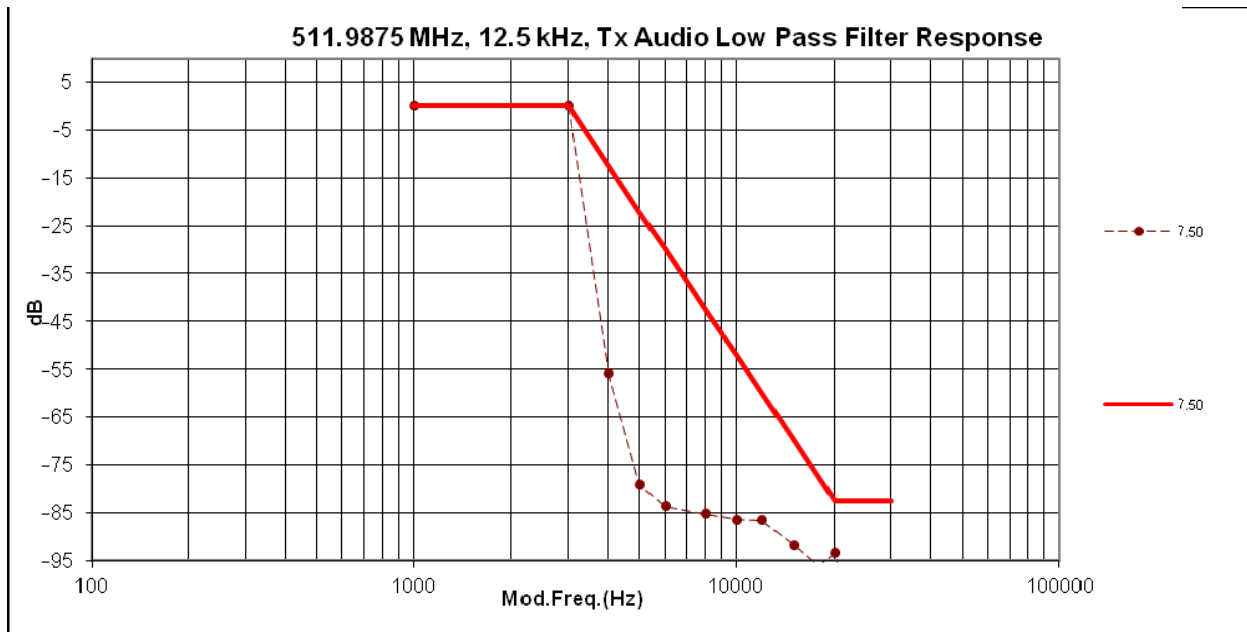
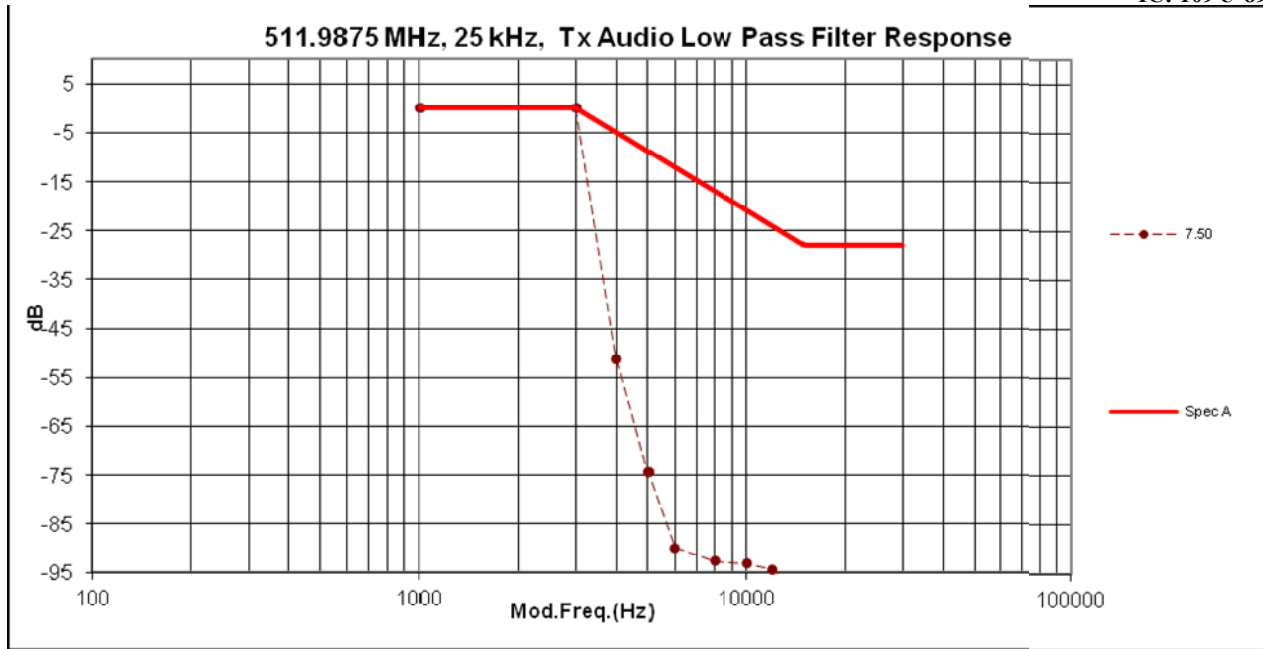

6.4.3. Test Limit

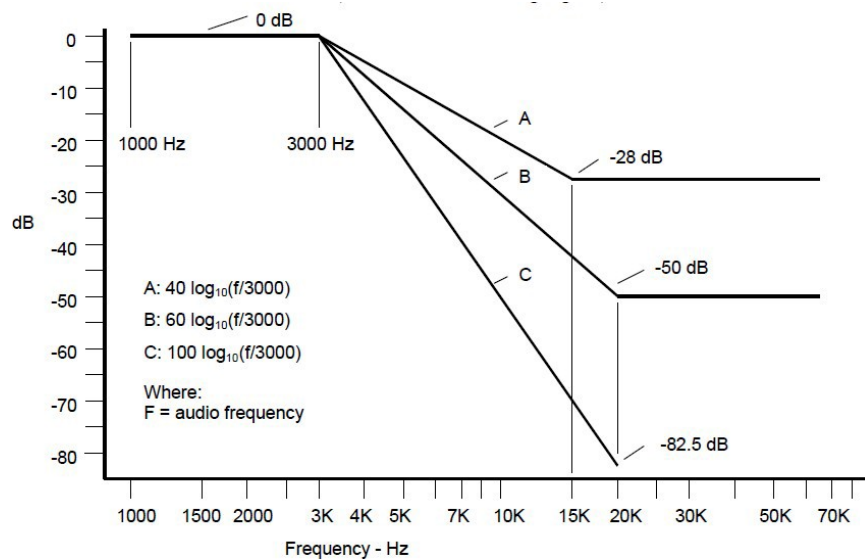

For audio frequencies above 3000 Hz, the audio response of the post limiter low-pass filter shall meet or exceed the following requirements:

- a) For equipment operating on 20, 25 or 30 kHz channel bandwidth in the 25 MHz to 174 MHz range:

At frequencies from 3000 Hz through 15,000 Hz the attenuation shall be greater than the attenuation at 1000 Hz by at least: $40 \log_{10}(f / 3000)$ dB

where: f is the audio frequency in Hz.

At frequencies above 15,000 Hz, the attenuation shall be greater than the attenuation at 1000 Hz, by at least: 28 dB.

- b) For equipment operating with 25 kHz bandwidth channels between 406 and 512 MHz through 896 MHz, and between 929 MHz through 930 MHz:

At frequencies from 3000 Hz through 20,000 Hz, the attenuation shall be greater than the attenuation at 1000 Hz by at least: $60 \log_{10}(f / 3000)$ dB

where: f is the audio frequency in Hz.

At frequencies above 20,000 Hz the attenuation shall be greater than the attenuation at 1000 Hz by at least: 50 dB.

- c) For equipment operating on channels between 896 MHz through 901 MHz, between 935 MHz through 940 MHz, and 12.5 or 15 kHz spaced channels in the frequency range 138-174 MHz and 406-512 MHz.

At frequencies from 3000 Hz through 20,000 Hz the attenuation shall be greater than the attenuation at 1000 Hz by at least: $100 \log_{10}(f / 3000)$ dB

where: f is the audio frequency in Hz.

6.5. Modulation Limiting

6.5.1. Test Setup

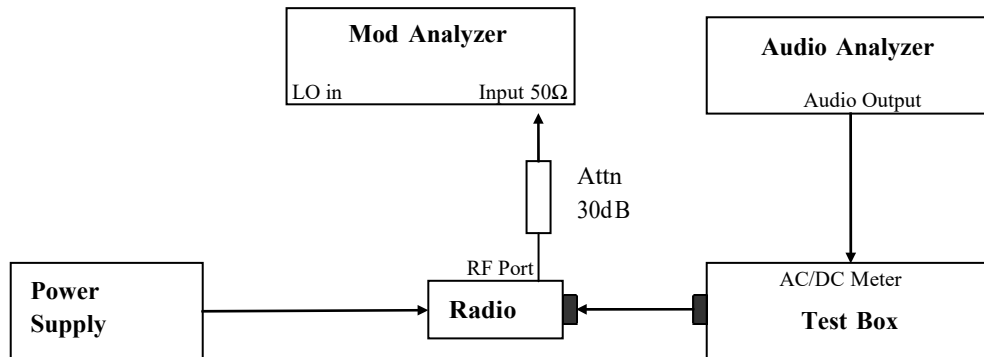

- 1) The DUT transmitter output port was connected to Modulation Analyzer.
- 2) Path loss for the measurement included.
- 3) Set the audio bandwidth filter to 15 kHz.
- 4) Transmit the radio and set the audio analyzer to 1 kHz audio frequency and 60% of the Full rated system deviation.
- 5) Record the frequency deviation as 0dB input level at 1kHz audio frequency.
- 6) Repeat the step and record the frequency deviation from -20 dB to 20dB by 5 dB increments and different audio freq 300 Hz, 2.5 kHz and 3 kHz.

6.5.2. Test Result

Not for FCC review

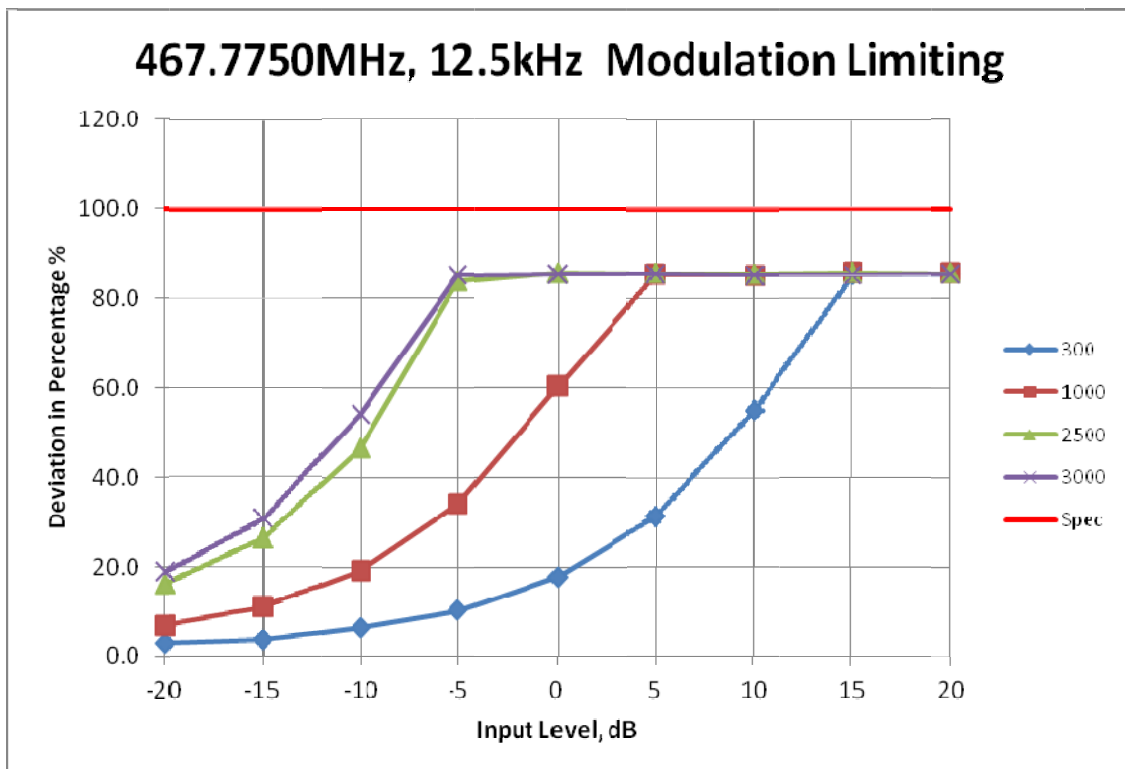
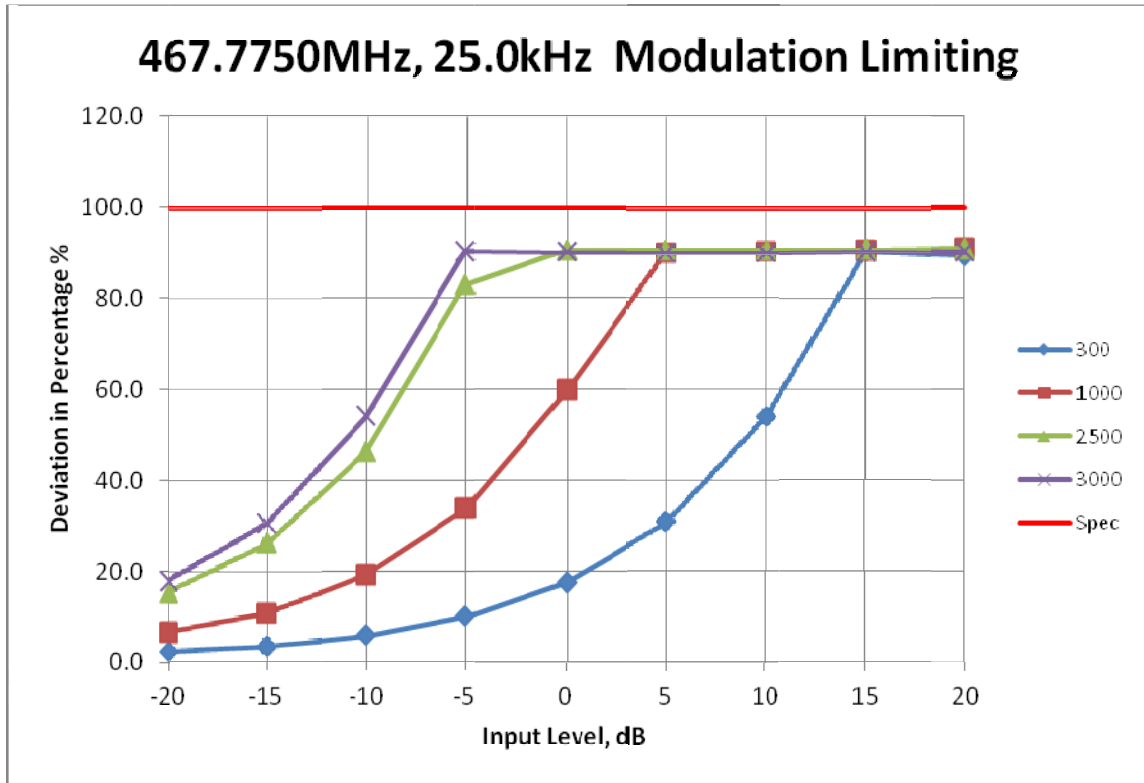

Not for FCC review

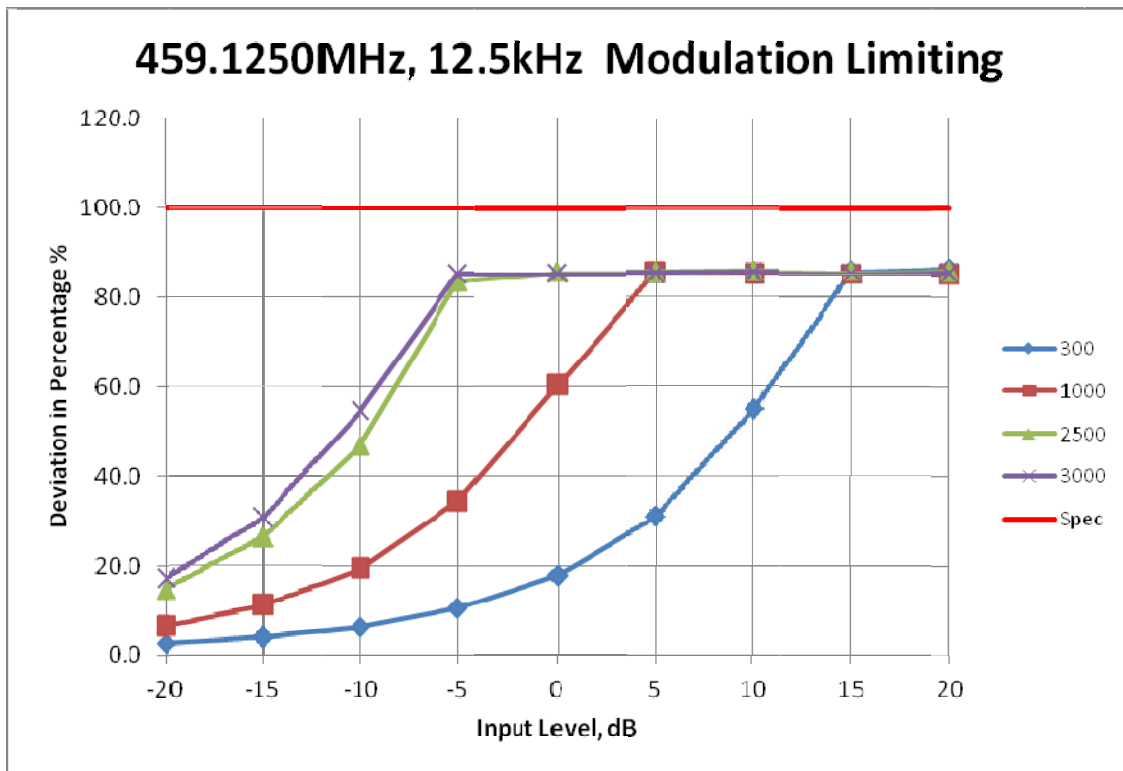
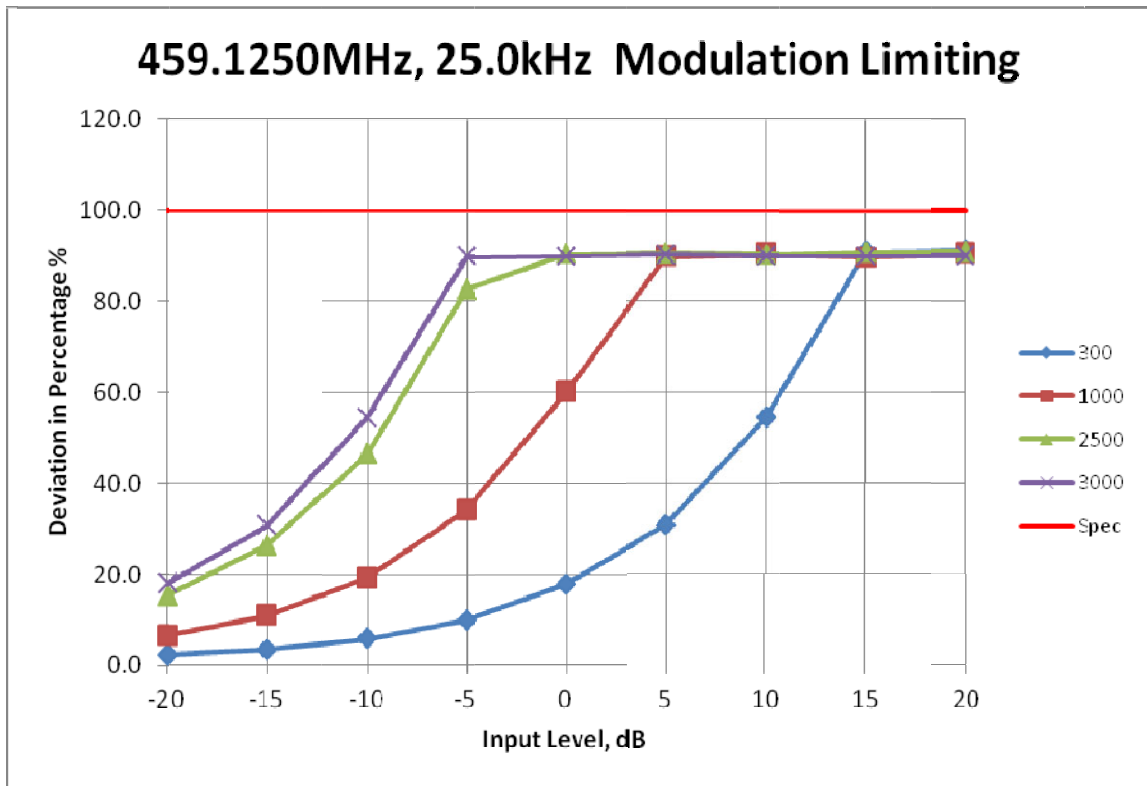

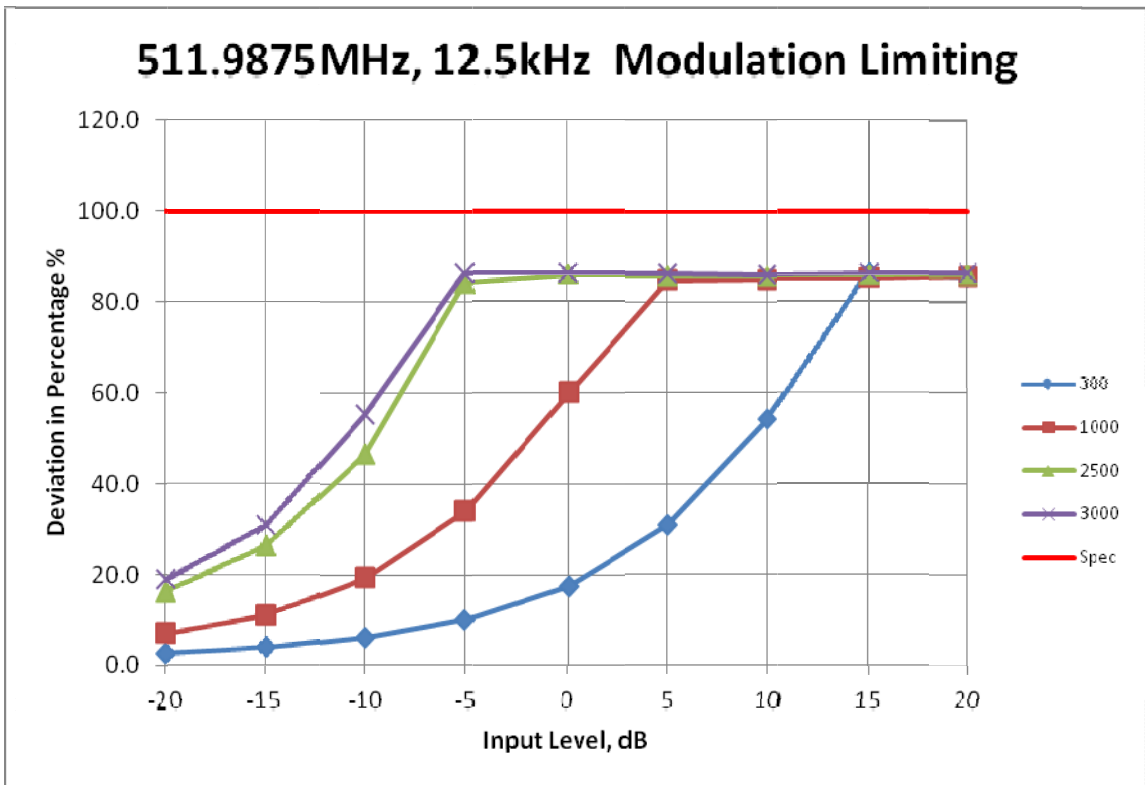
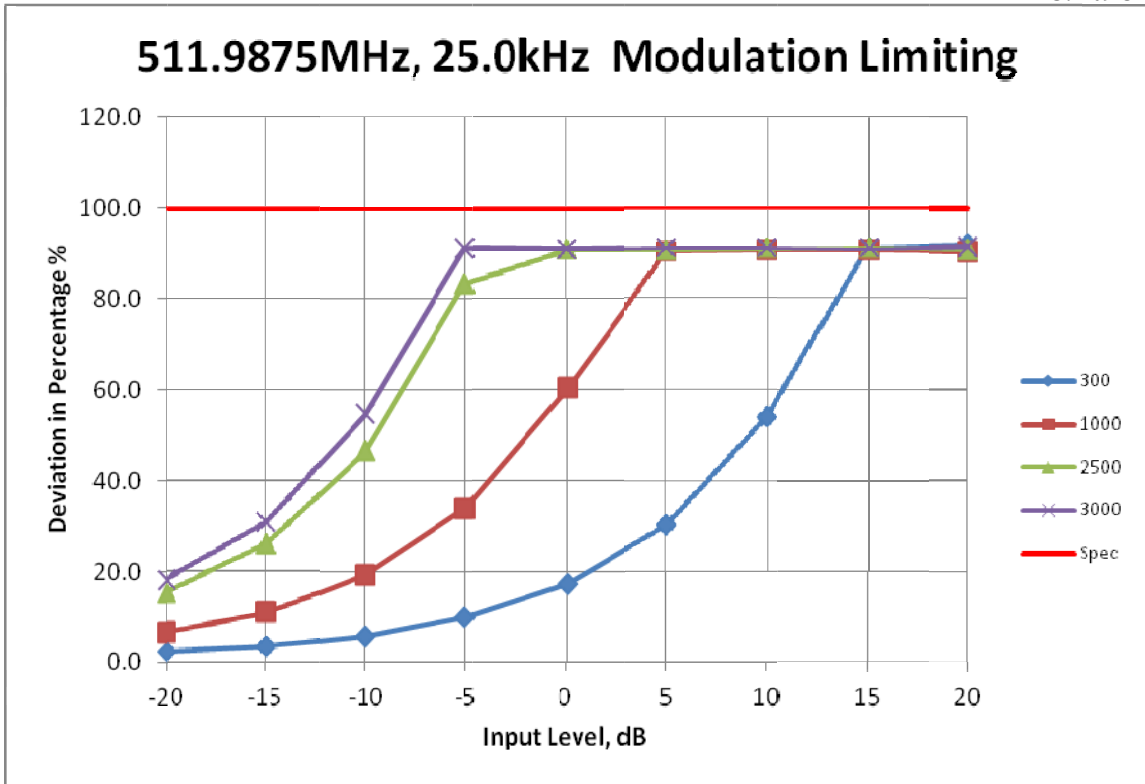

6.5.3. Test Limit
 Modulation Limiting shall not exceed 100 percent.

6.6. Occupied Bandwidth

6.6.1. Test Setup (Analog)

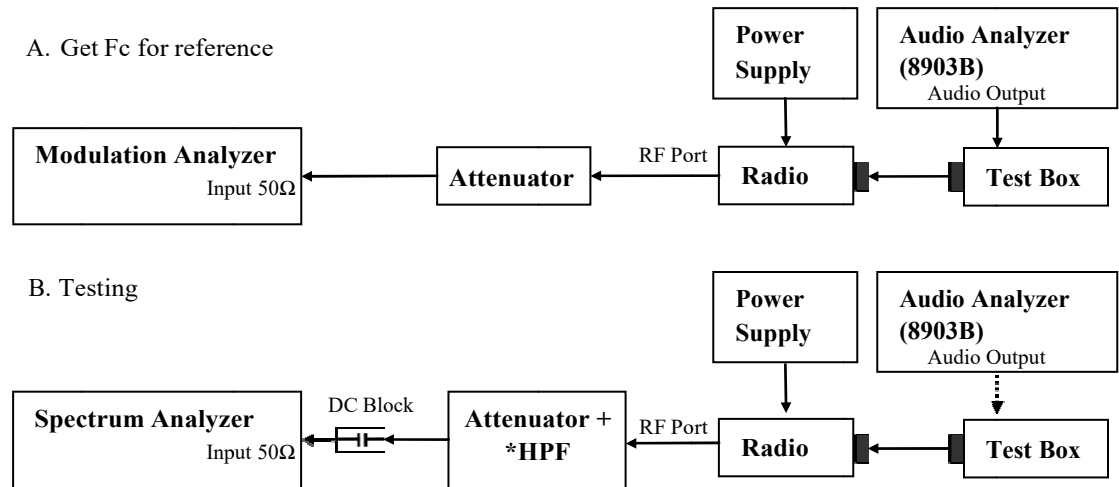

- 1) The DUT transmitter output port was connected to Modulation Analyzer.
- 2) Set the audio bandwidth filter to 15 kHz low pass filter and 50 kHz high pass filter.
- 3) Transmit the radio and set the audio analyzer to 2.5 kHz audio frequency and 50% of the rated deviation. Up the amplitude by 16 dB. Dekey the DUT.
- 4) Path loss for the measurement included.
- 5) Select the Occupied Bandwidth measurement for 99% Emissions Bandwidth Measurement.
- 6) Key in the Fc and Resolution Bandwidth (1 ~ 5 % of emission designator).
- 7) Transmit the DUT and record the occupied Bandwidth frequency.
- 8) Preset the spectrum analyzer for sideband spectrum measurement.
- 9) Set the span and Resolution Bandwidth (according to FCC/ ISED standard).
- 10) Save the screen shot as modulated signal
- 11) Remove the audio tone from audio analyzer to capture unmodulated signal.

* Only HPF added for Mask 80.211 measurement with attenuator.

* 99% Bandwidth measurement is computed by the spectrum analyzer and is consistent with the C63.26 5.4.4 method.

6.6.2. Test Result (Analog)

Standard Audio Modulation (25 kHz Channelization, Analog Voice):
Emission Designator 16K0F3E

In this case, the maximum modulating frequency is 3 kHz with a 5 kHz deviation.

$BW = 2(M+D) = 2*(3 \text{ kHz} + 5 \text{ kHz}) = 16 \text{ kHz} = 16K0$
F3E portion of the designator indicates voice.

Therefore, the entire designator for 25 kHz channelization analog voice is 16K0F3E.

Standard Audio Modulation (12.5 kHz Channelization, Analog Voice):
Emission Designator 11K0F3E

In this case, the maximum modulating frequency is 3.0 kHz with a 2.5 kHz deviation.

$BW = 2(M+D) = 2*(3.0 \text{ kHz} + 2.5 \text{ kHz}) = 11 \text{ kHz} = 11K0$
F3E portion of the designator indicates voice.

Therefore, the entire designator for 12.5 kHz channelization analog voice is 11K0F3E.

Not for FCC review

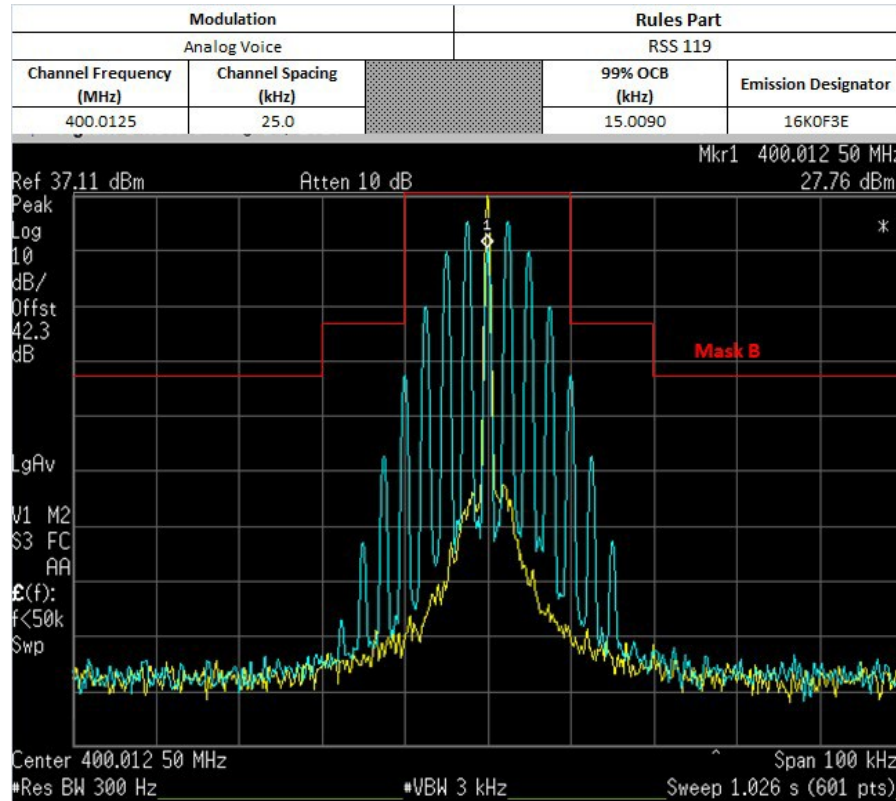

Not for FCC review

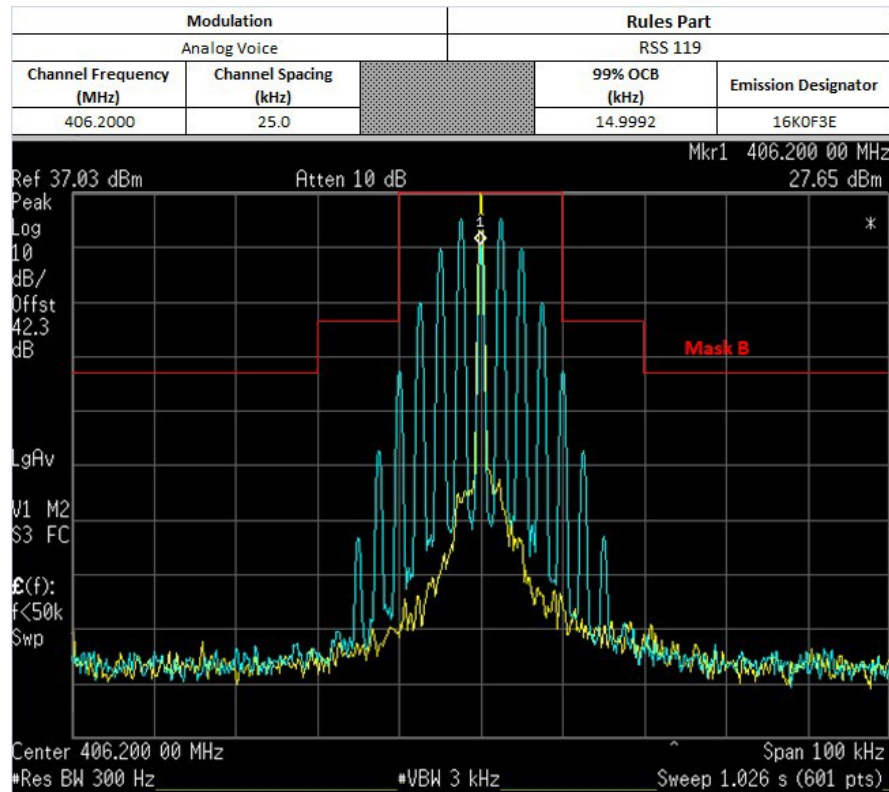

For Part 74

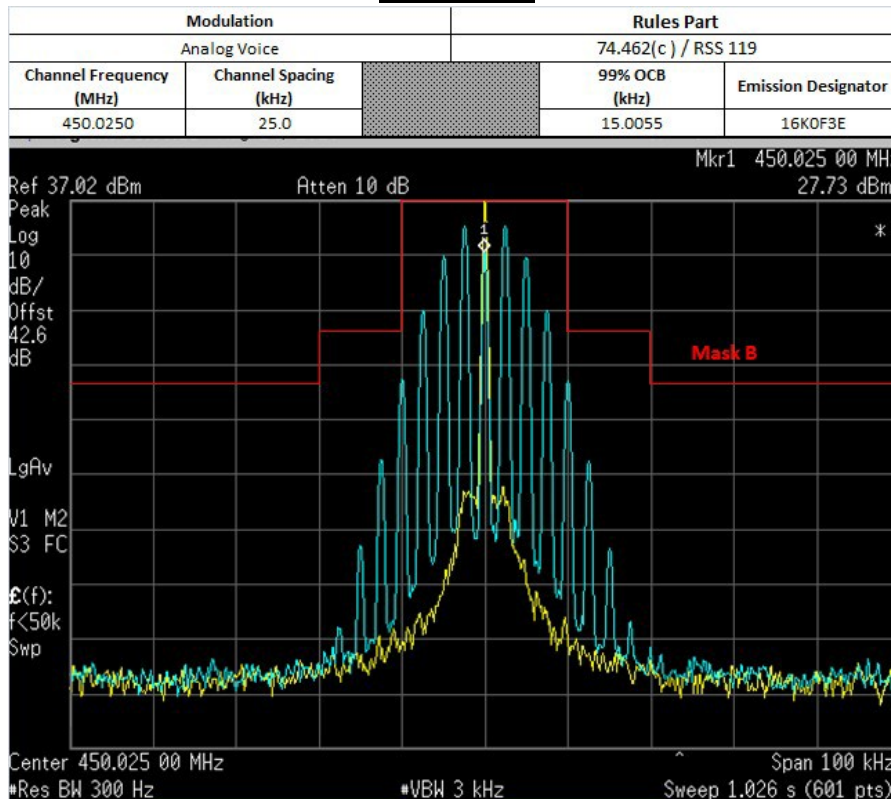

For Part 80

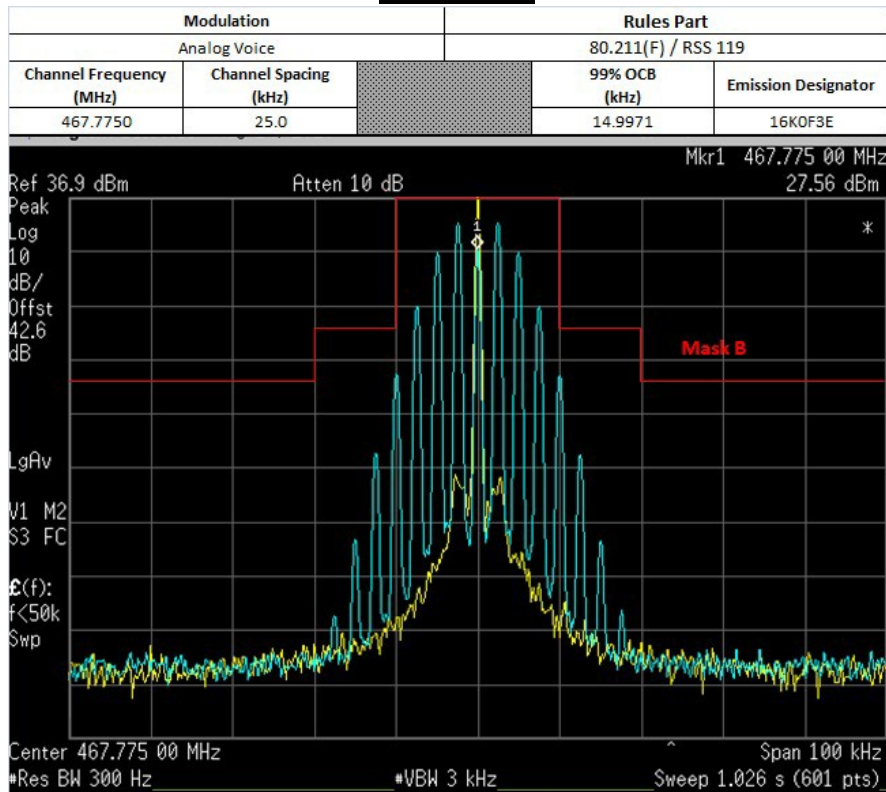

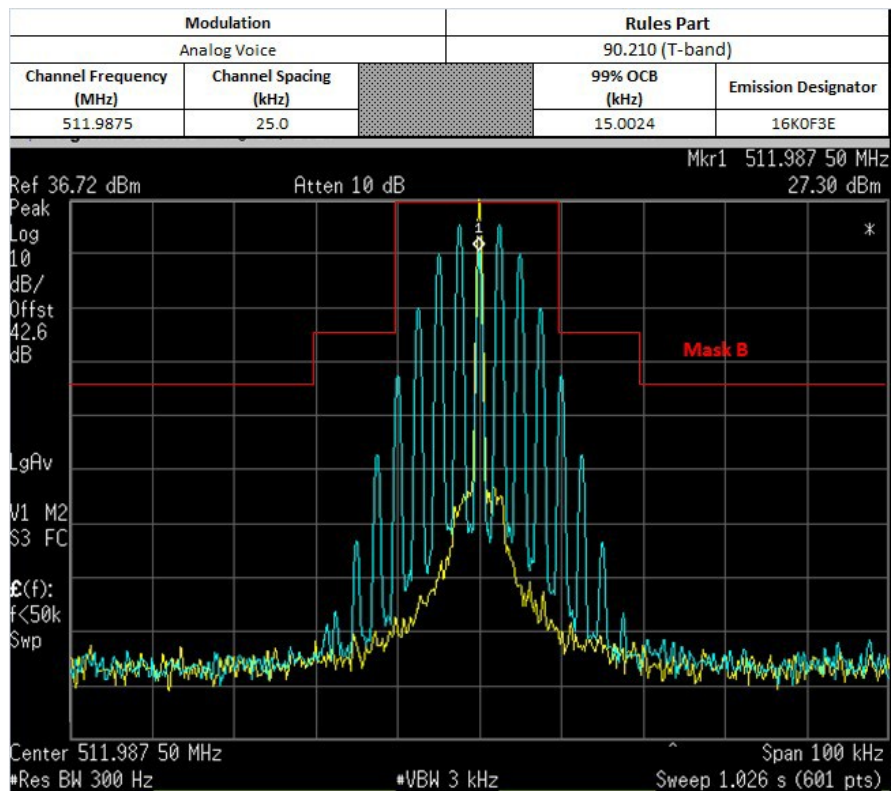
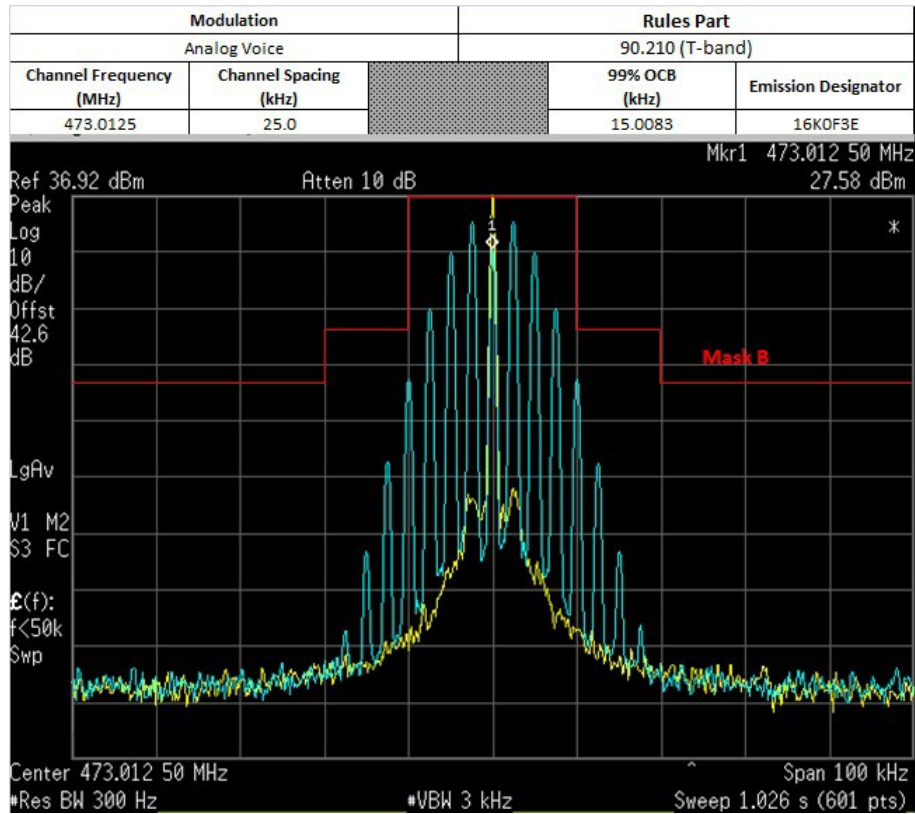

Not for FCC review

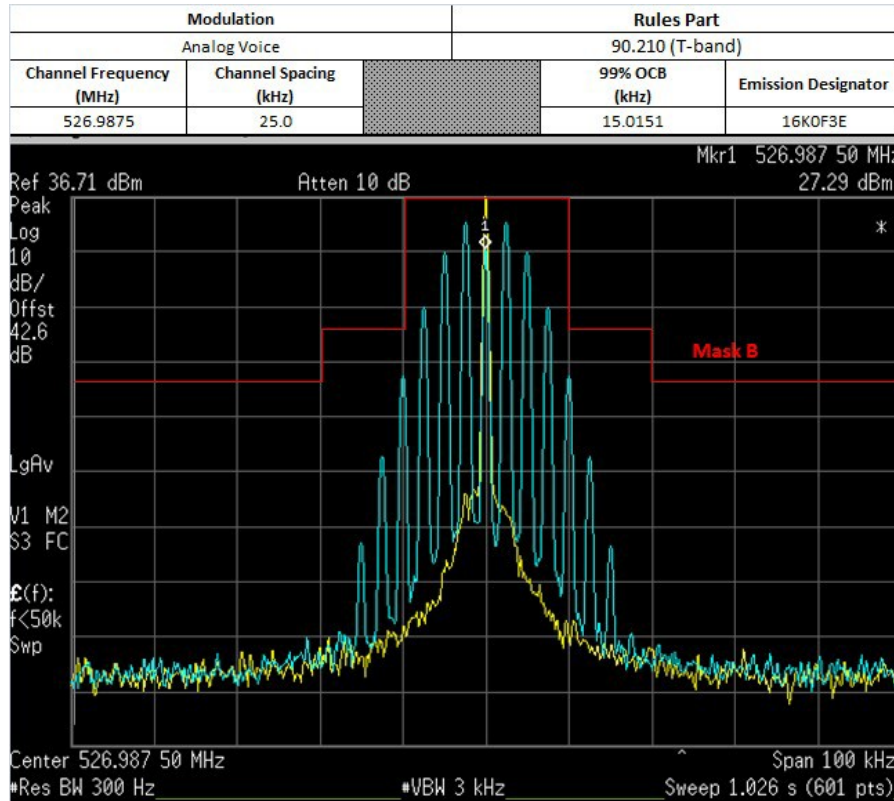

Not for FCC review

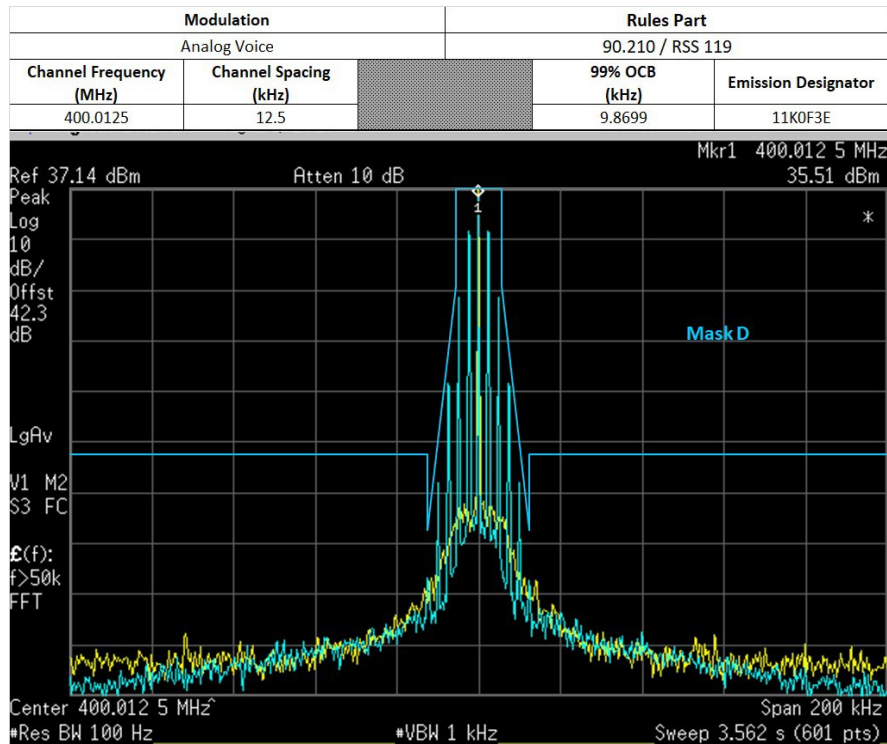

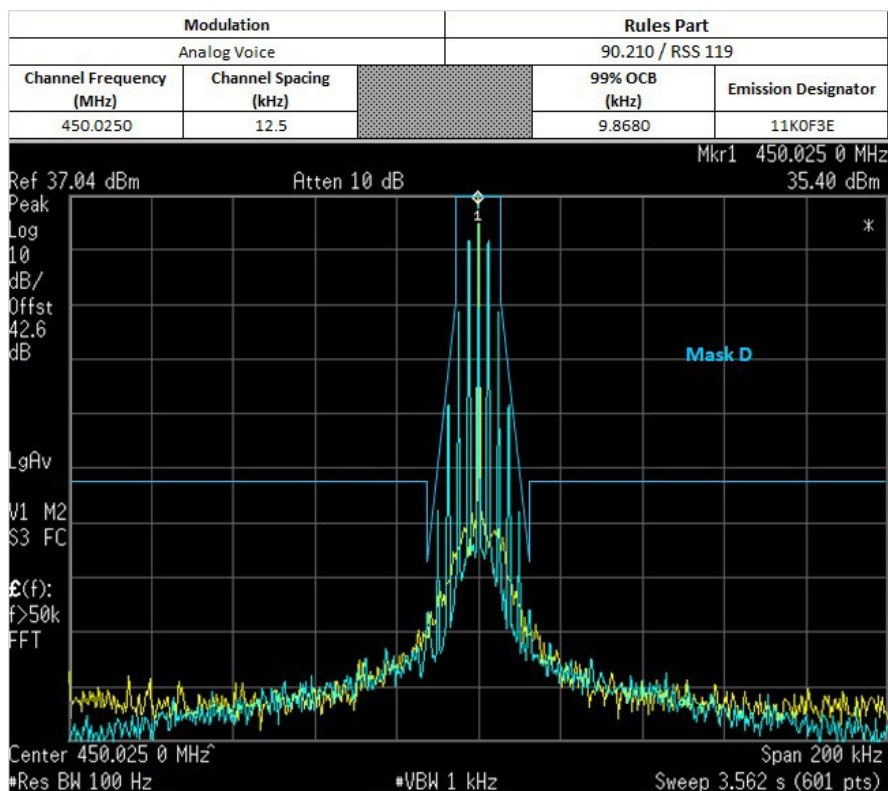
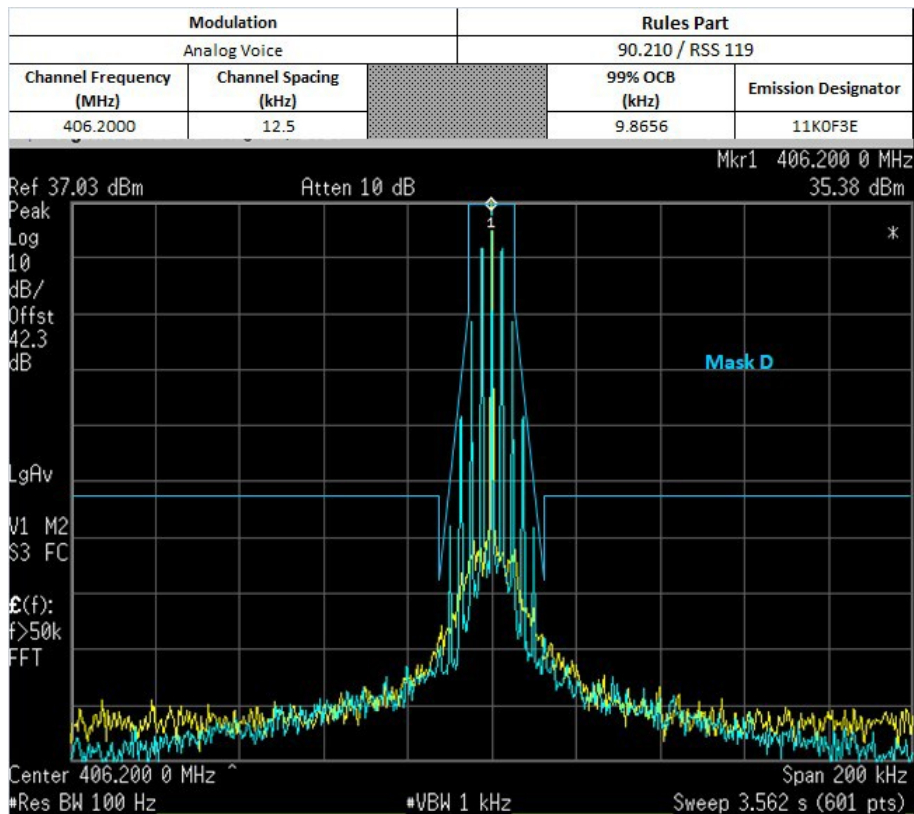

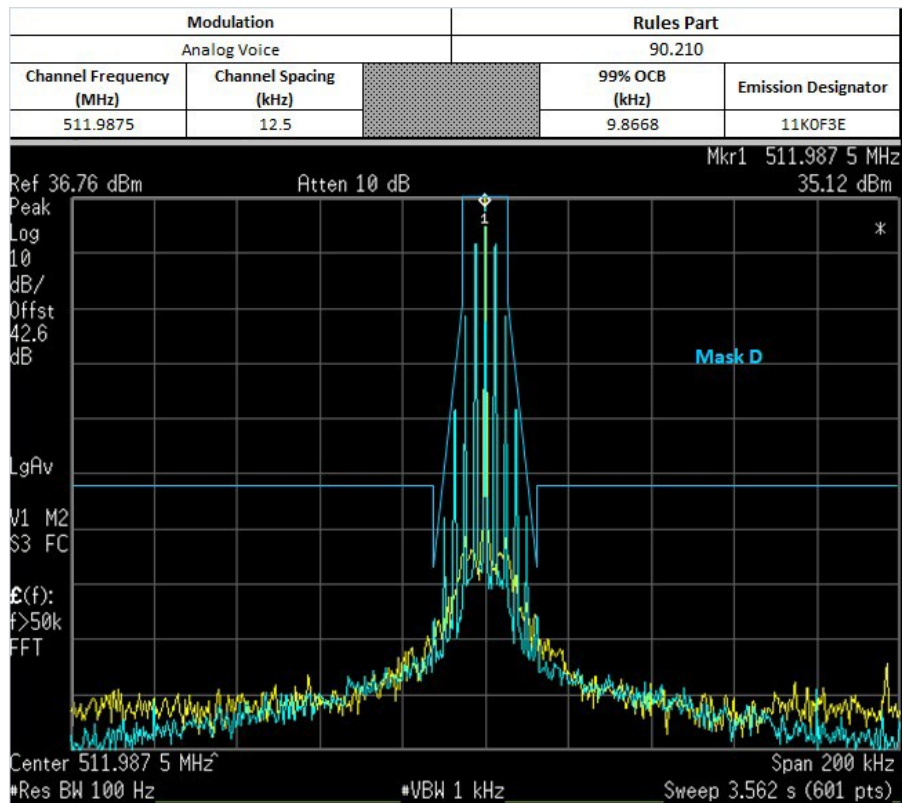
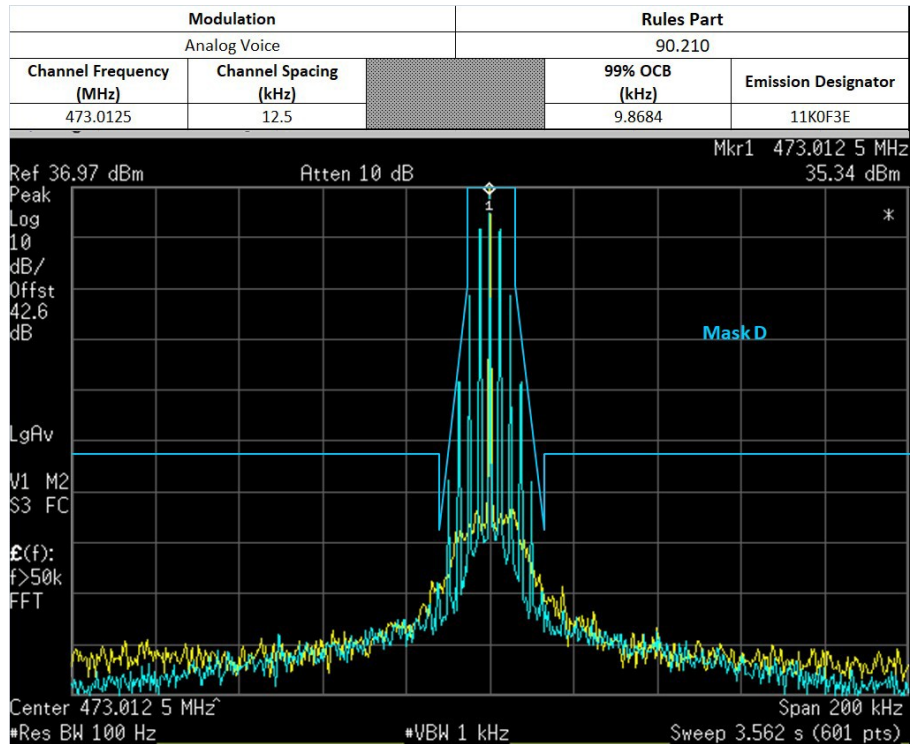

Not for FCC review

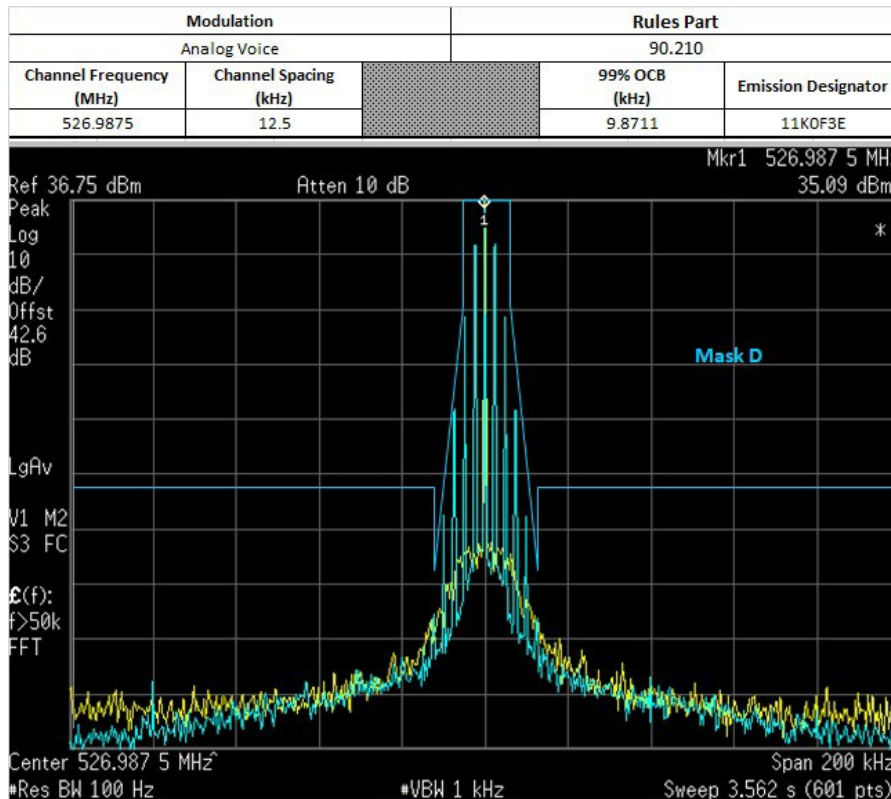

Part 80 only

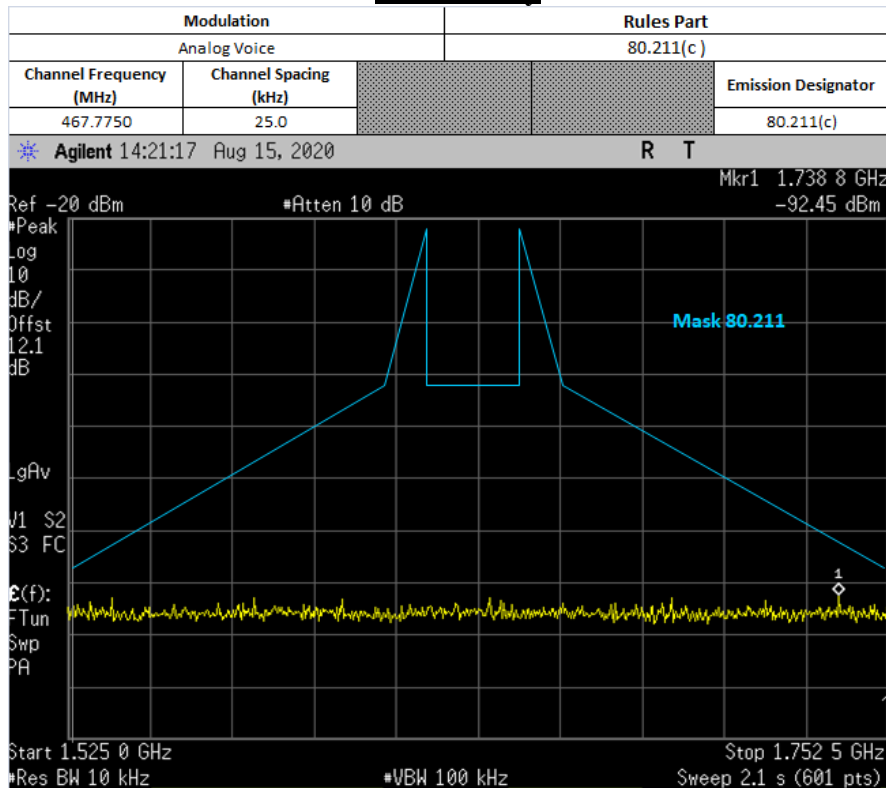

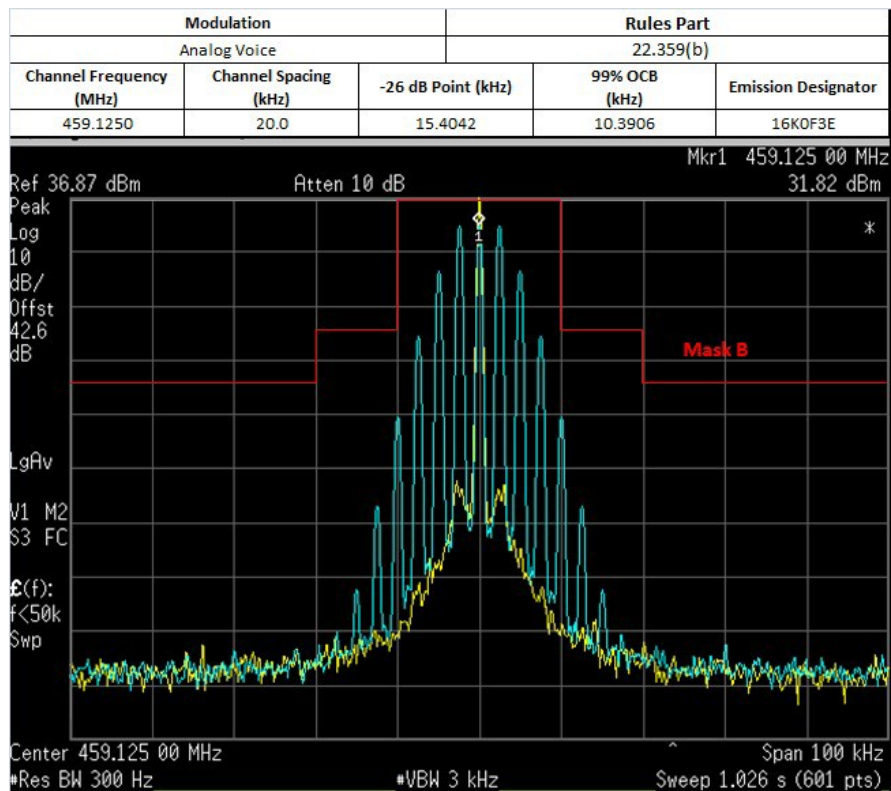
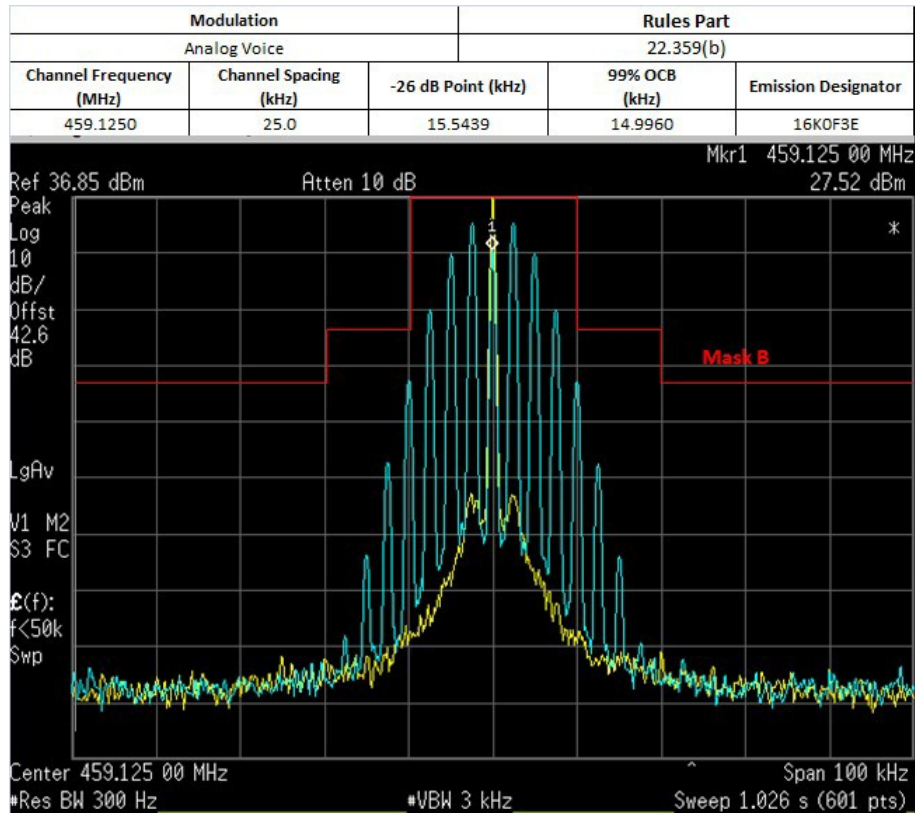

6.6.3. Test Setup (Digital)

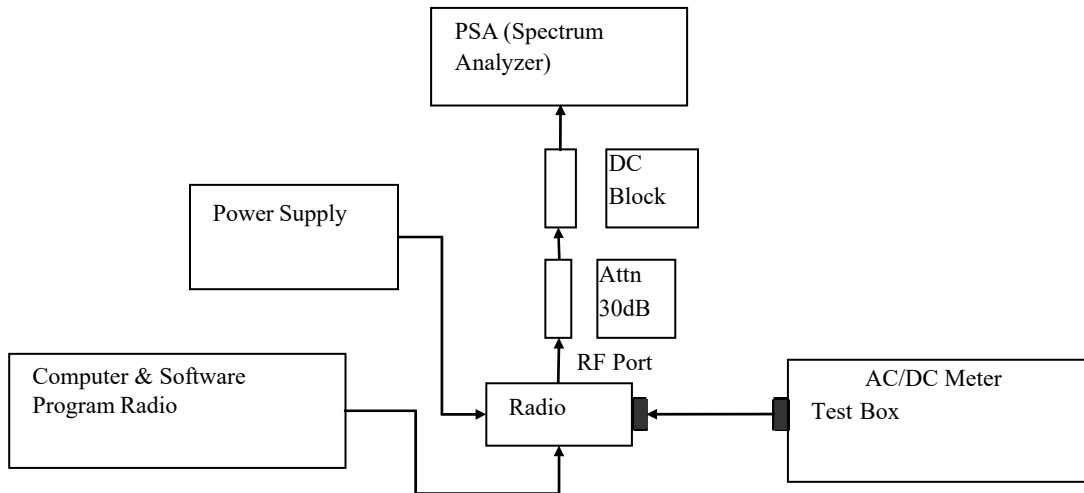

- 1) Program and set radio to operate in desire test frequency and digital mode with modulation. (*4FSK, C4FM or other digital modulation form).
- 2) Path loss for the measurement included.
- 3) Select the Occupied Bandwidth measurement for 99% Emissions Bandwidth Measurement.
- 4) Key in the Fc and Resolution Bandwidth (1 ~ 5 % of emission designator).
- 5) Transmit the DUT and record the occupied Bandwidth frequency.
- 6) Preset the spectrum analyzer for modulation emission spectrum measurement.
- 7) Set the span and Resolution Bandwidth (according to FCC/ ISED standard).
- 8) Capture the screen shot as modulated signal.

* 99% Bandwidth measurement is computed by the spectrum analyzer and is consistent with the C63.26 5.4.4 method.

* Note:

- For Digital Modulation, 12.5 kHz Data F1D & FXD would be the same. Therefore only measurements with F1D modulation shown below.
- For Digital Modulation, 12.5 kHz Data F1E & FXE would be the same. Therefore only measurements with F1E modulation shown below.

6.6.4. Test Result (Digital)

Digital (12.5 kHz Channelization, Digital Voice/Data/Voice+Data):
Emission Designator 7K60F1E/D/W

The 99% energy rule (title 47CFR 2.989) was used for digital mode and is more accurate than Carson's rule. It basically states that 99% of the modulation energy falls within X kHz, in this case, 7.60 kHz. Measurements were performed in accordance with TIA/EIA TSB102.CAAB Section 2.2.5.2. The emission mask was obtained from 47CFR 90.210(d).

F1E/D/W portion of the designator indicates digital voice/data/voice+data.

Therefore, the entire designator for 12.5 kHz channelization digital voice/ data/voice+data. is 7K60F1E/D/W.

Not for FCC review

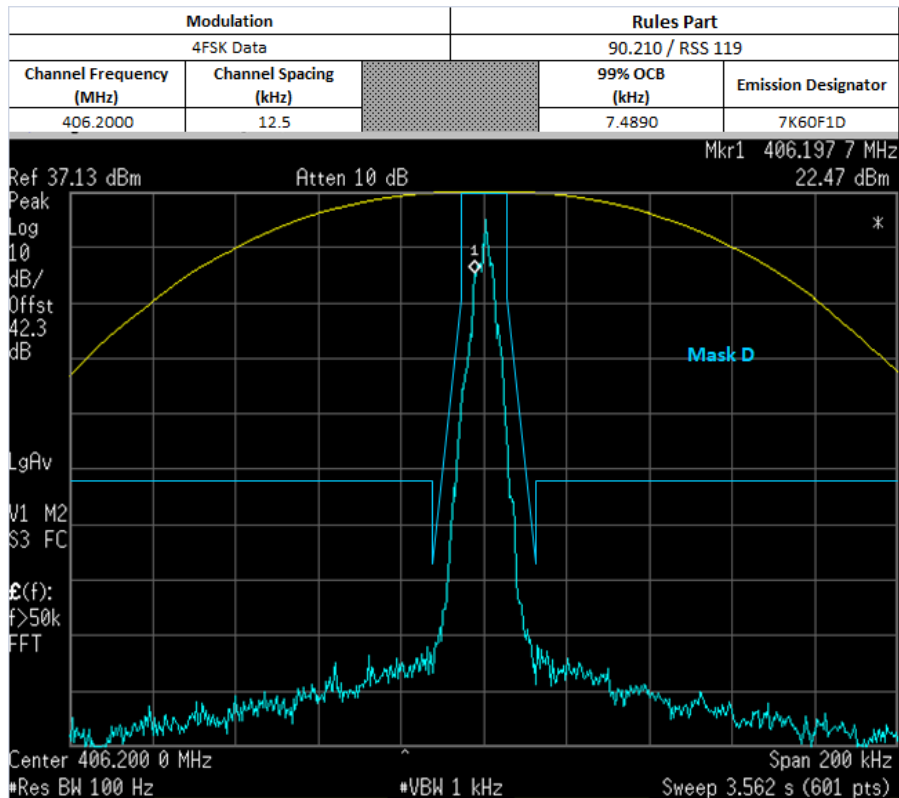
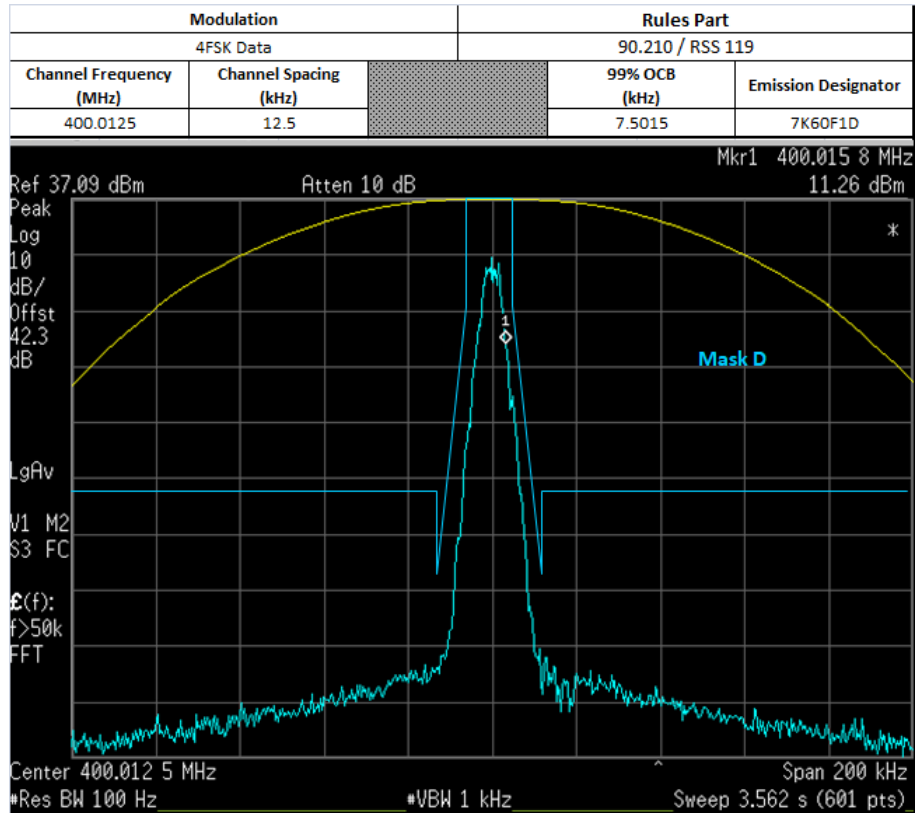

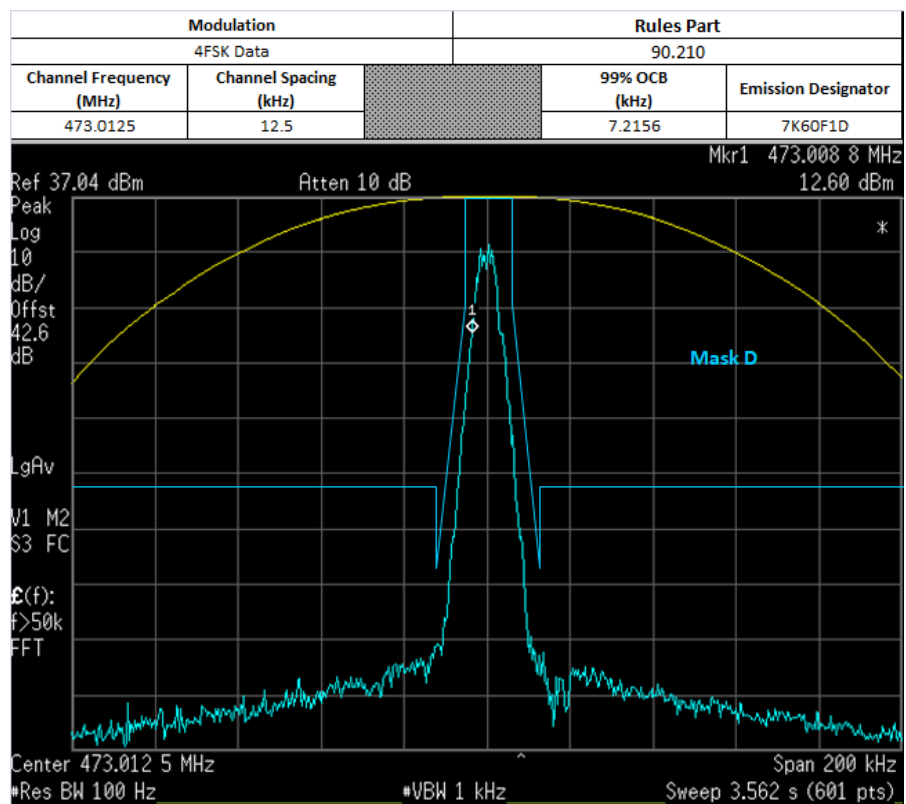
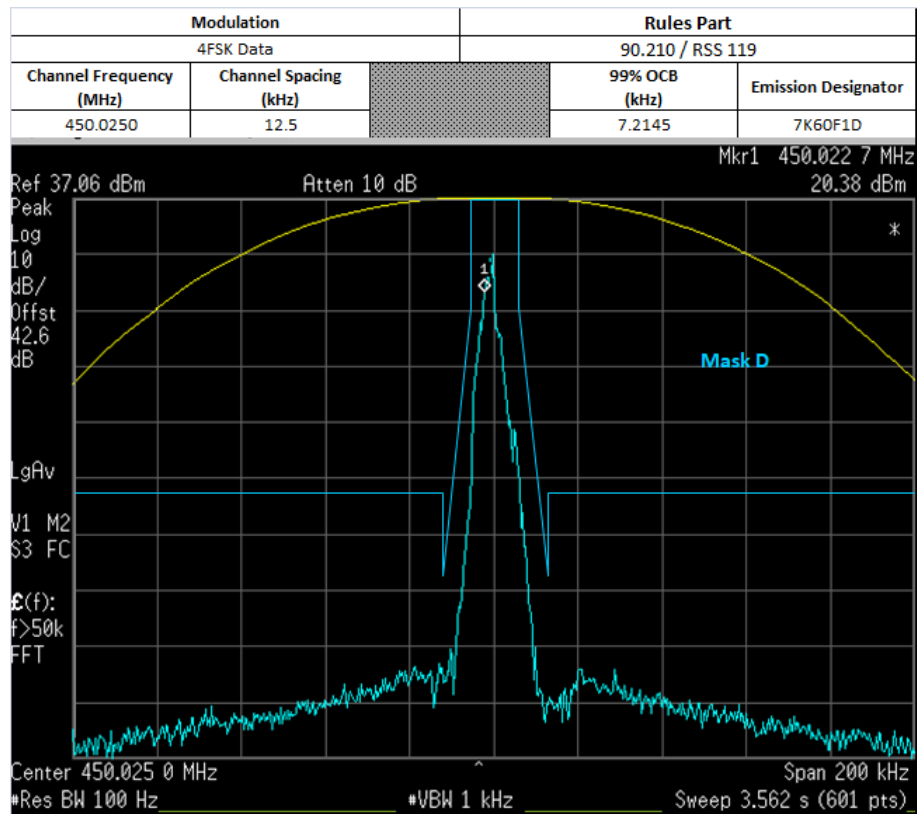

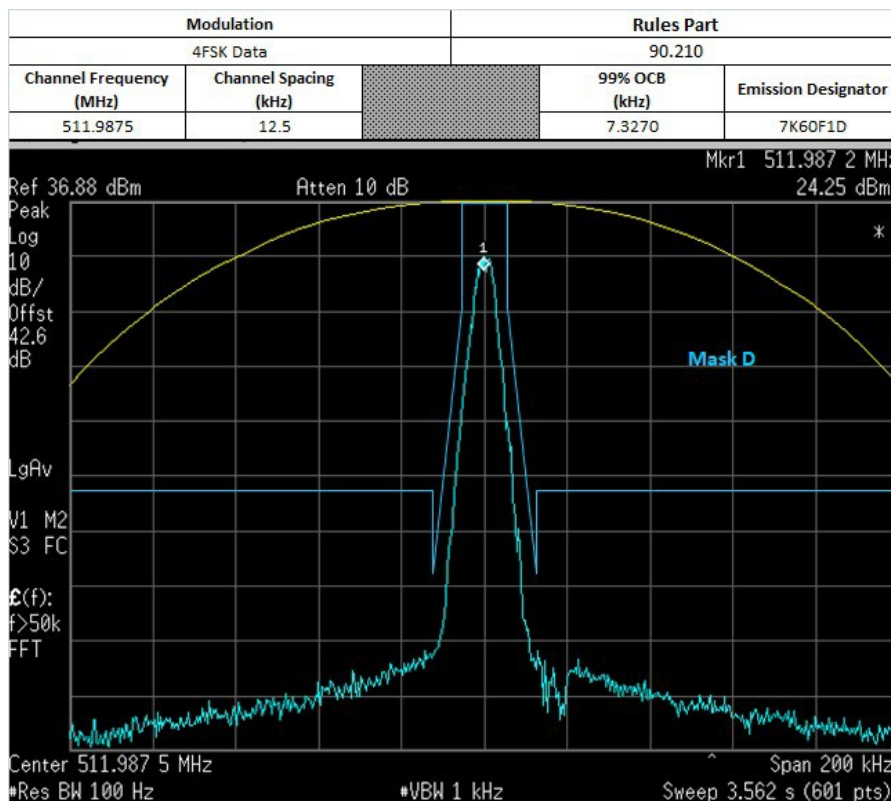

Not for FCC review

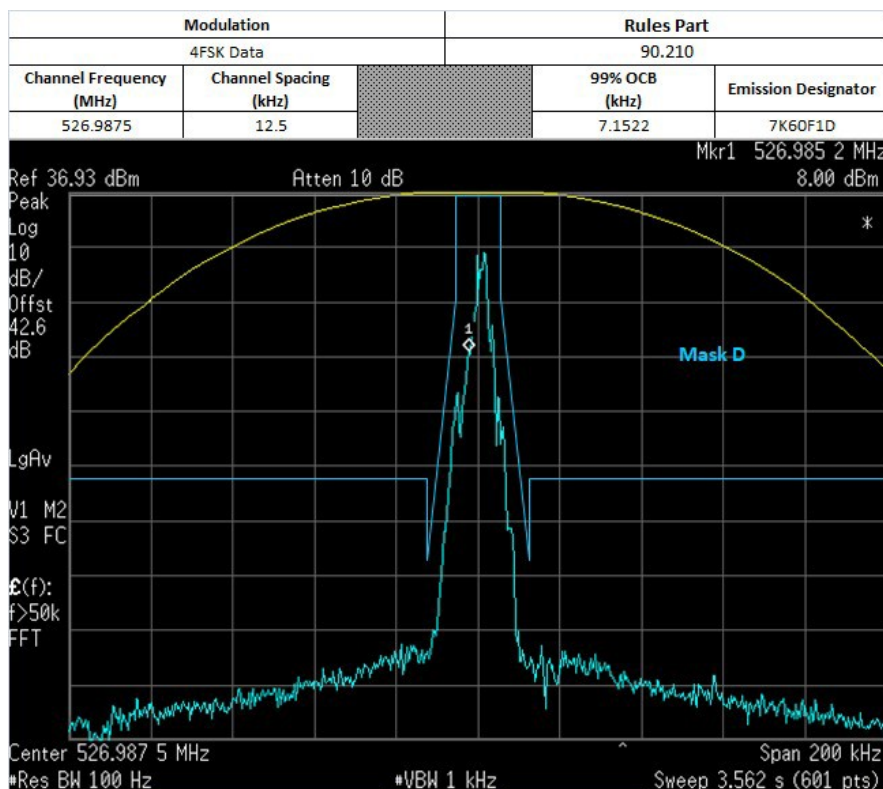

Not for FCC review

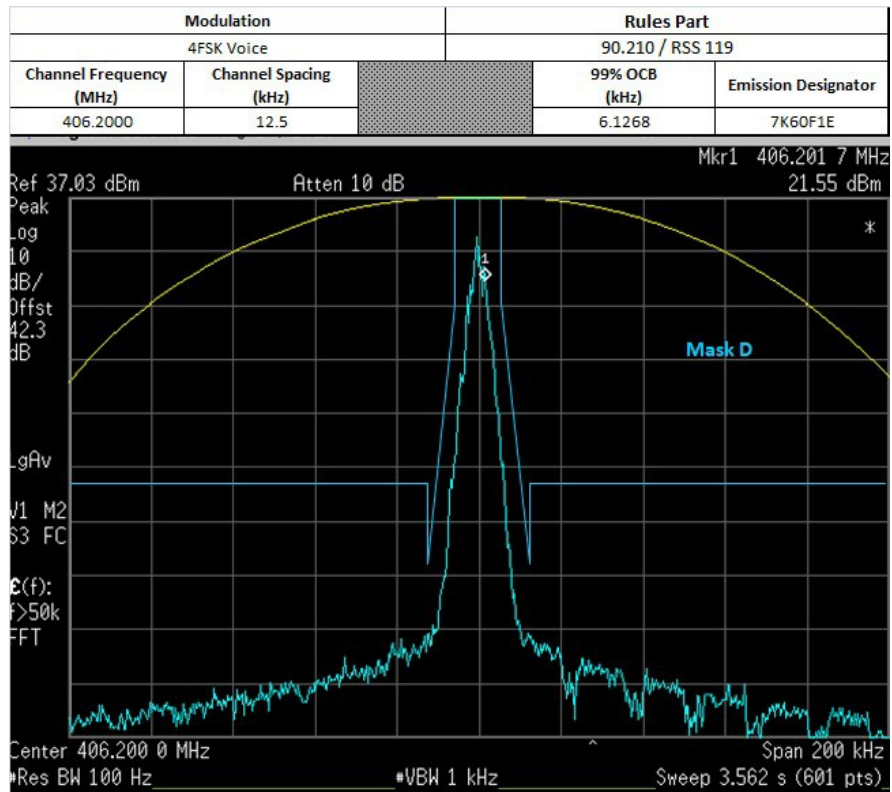
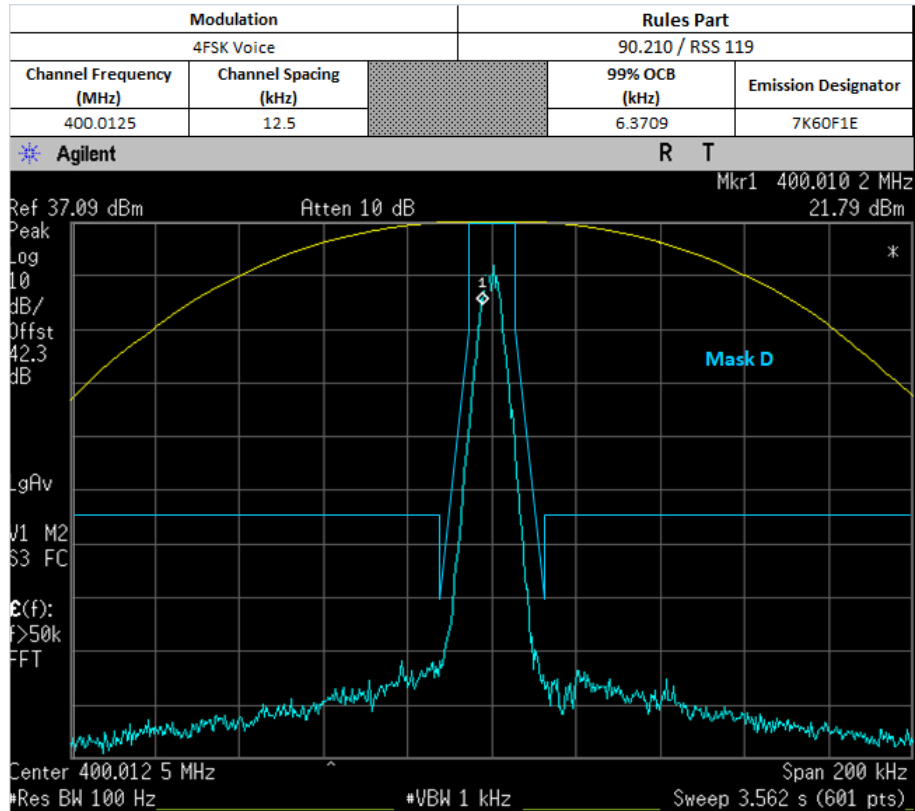

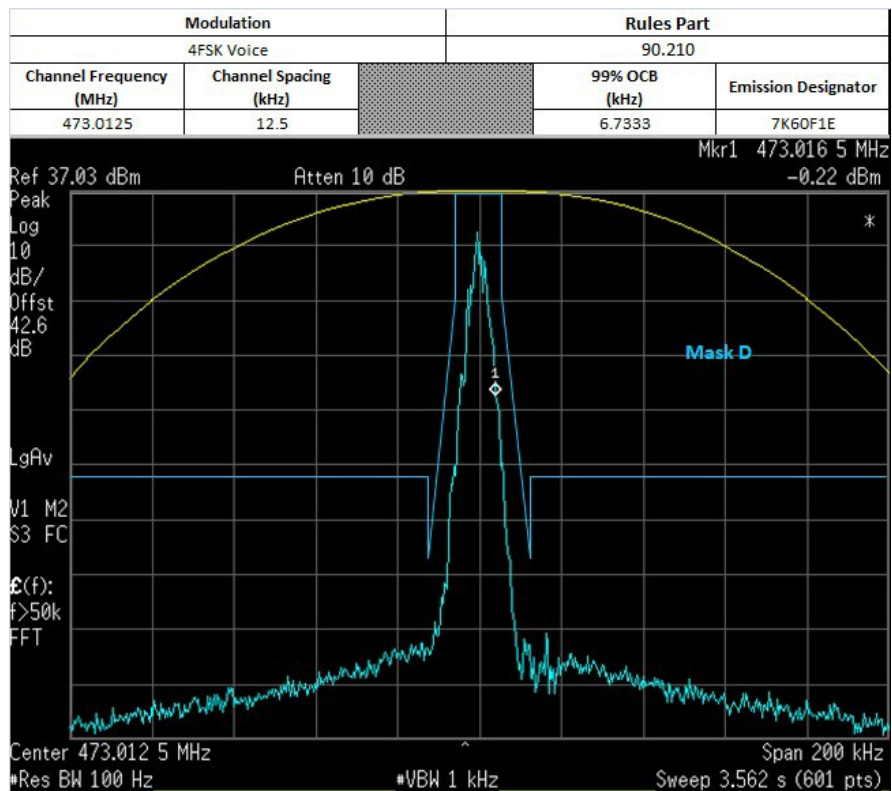
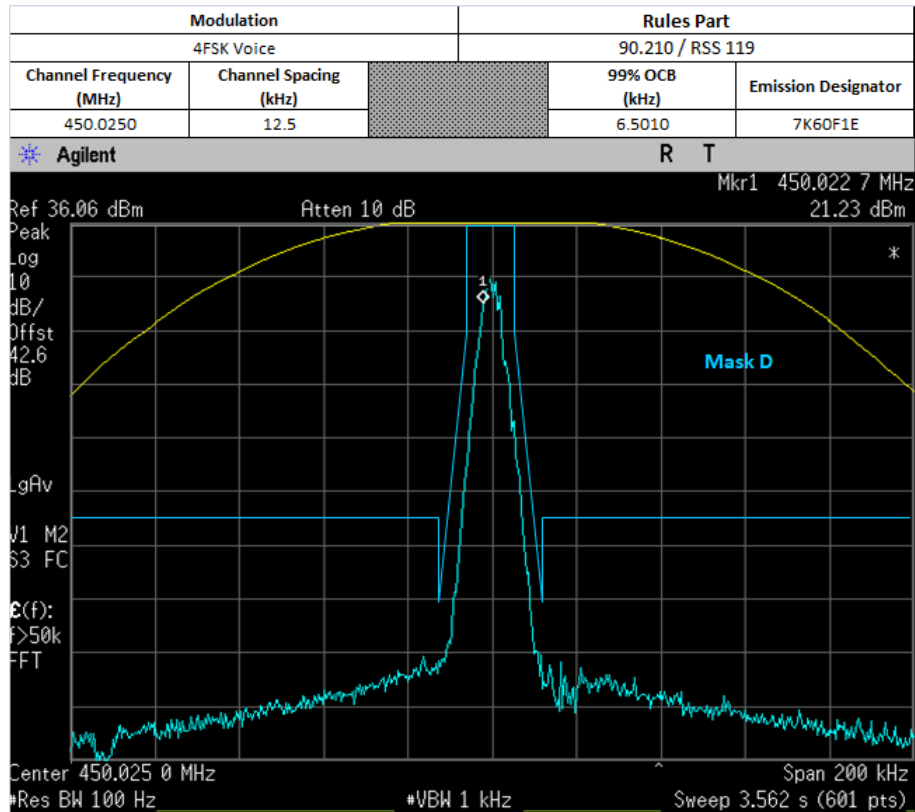

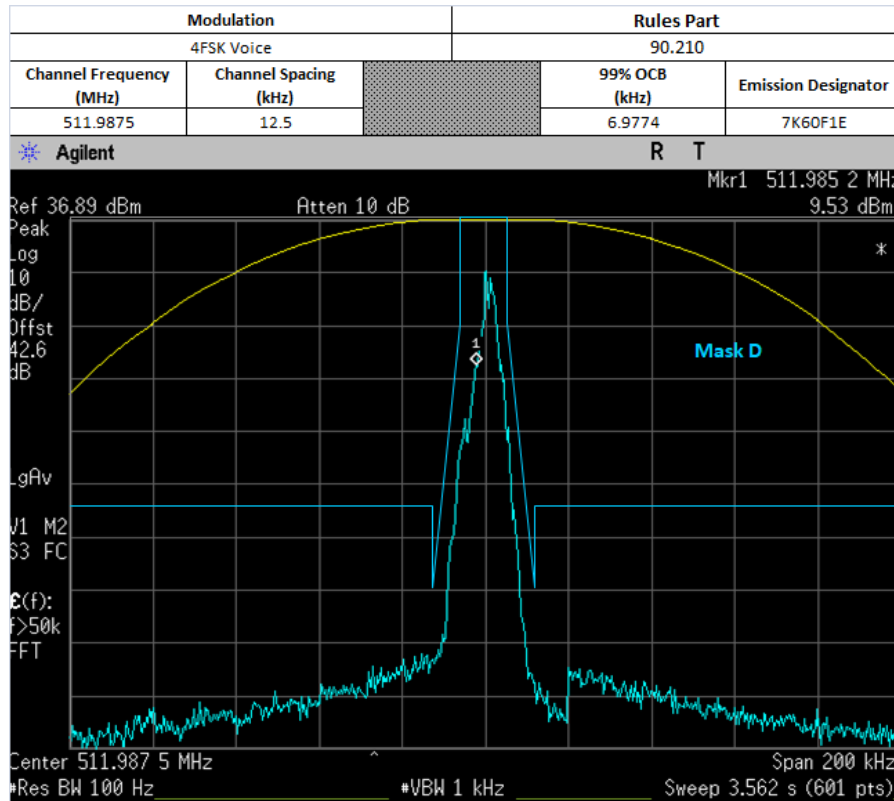

Not for FCC review

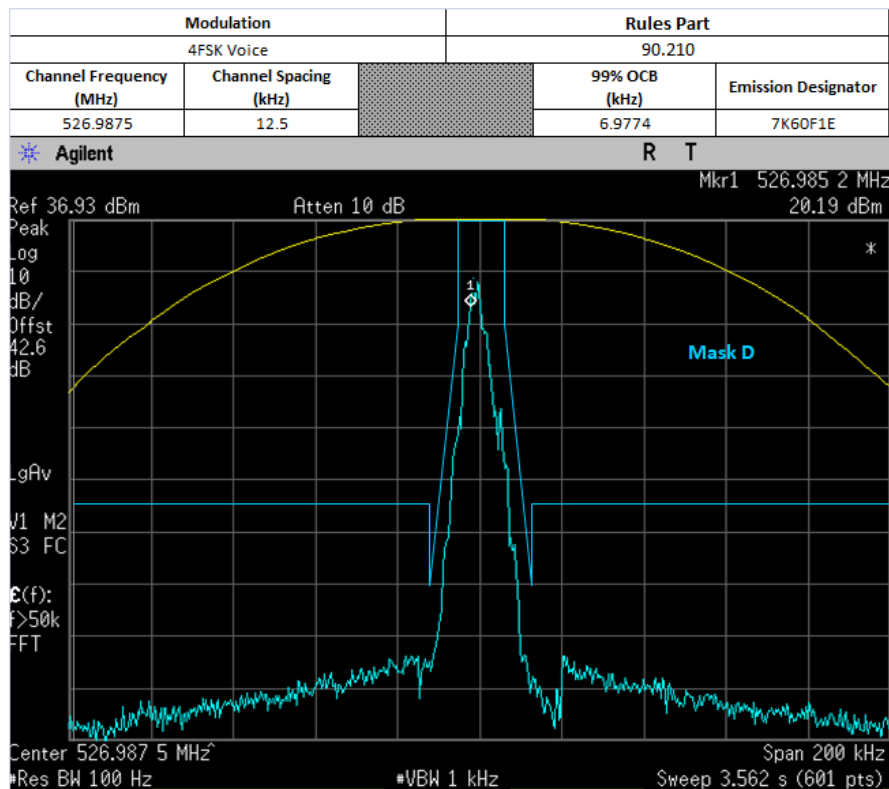

Not for FCC review

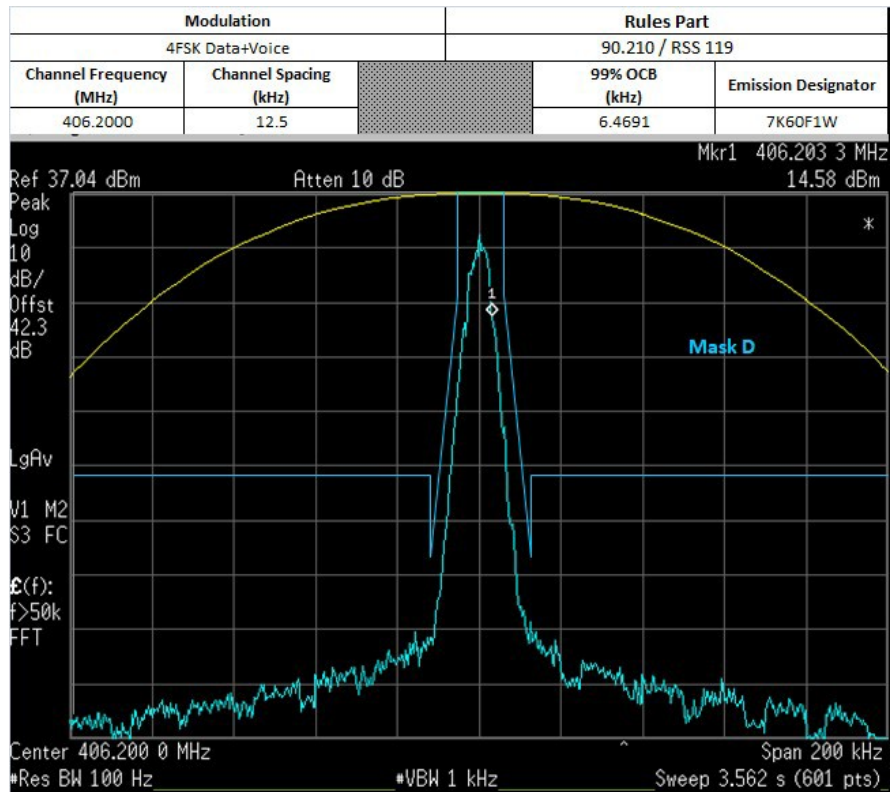
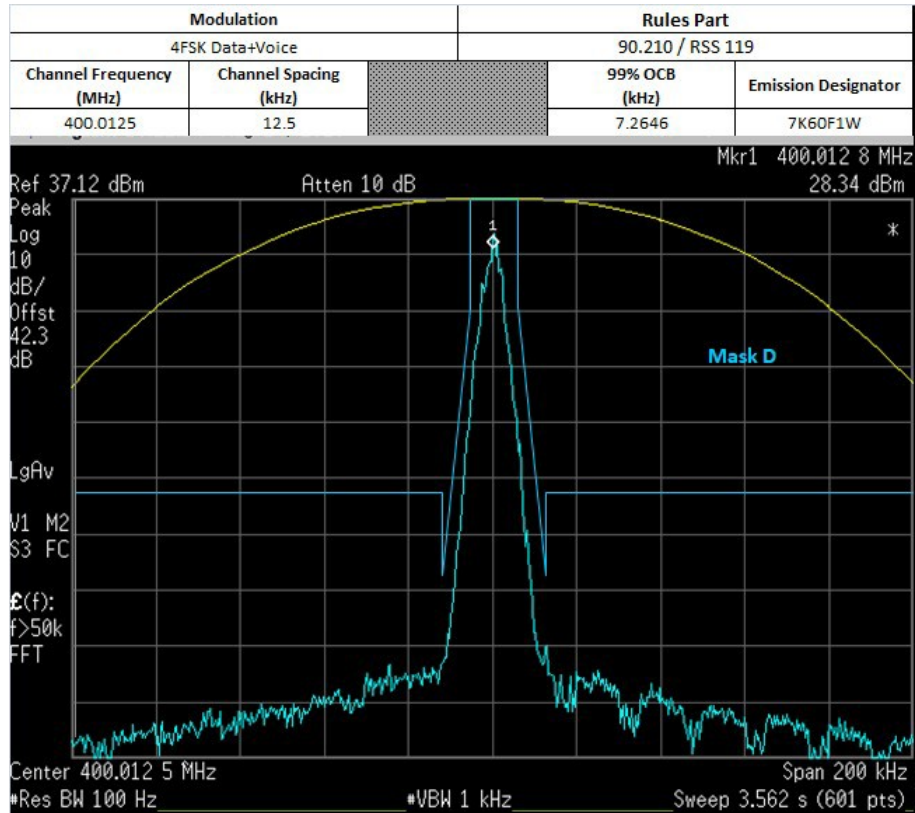

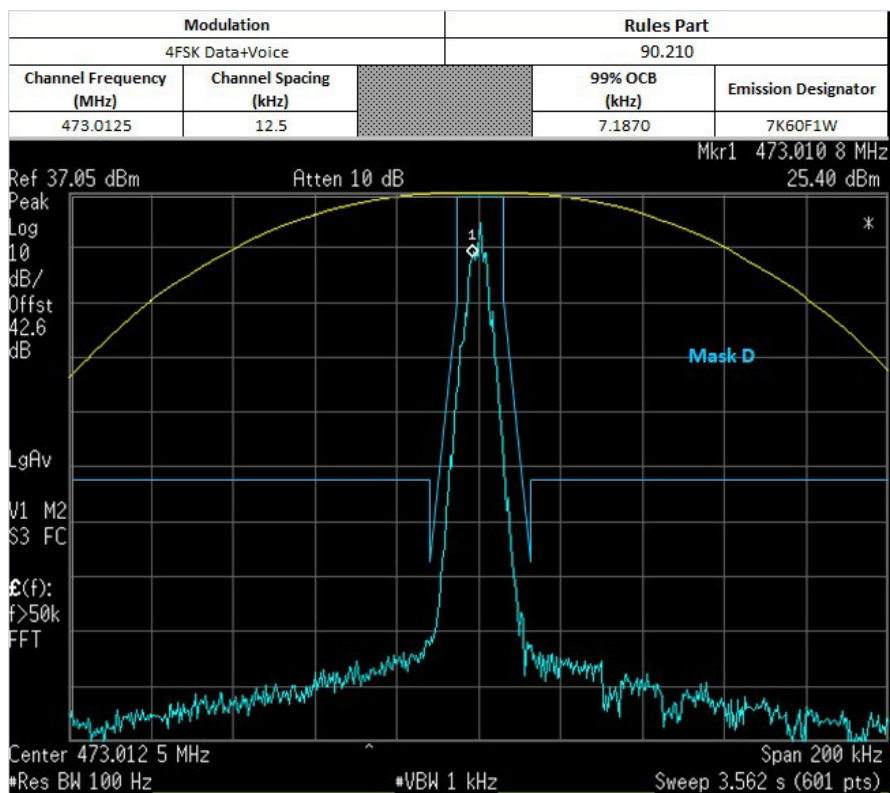
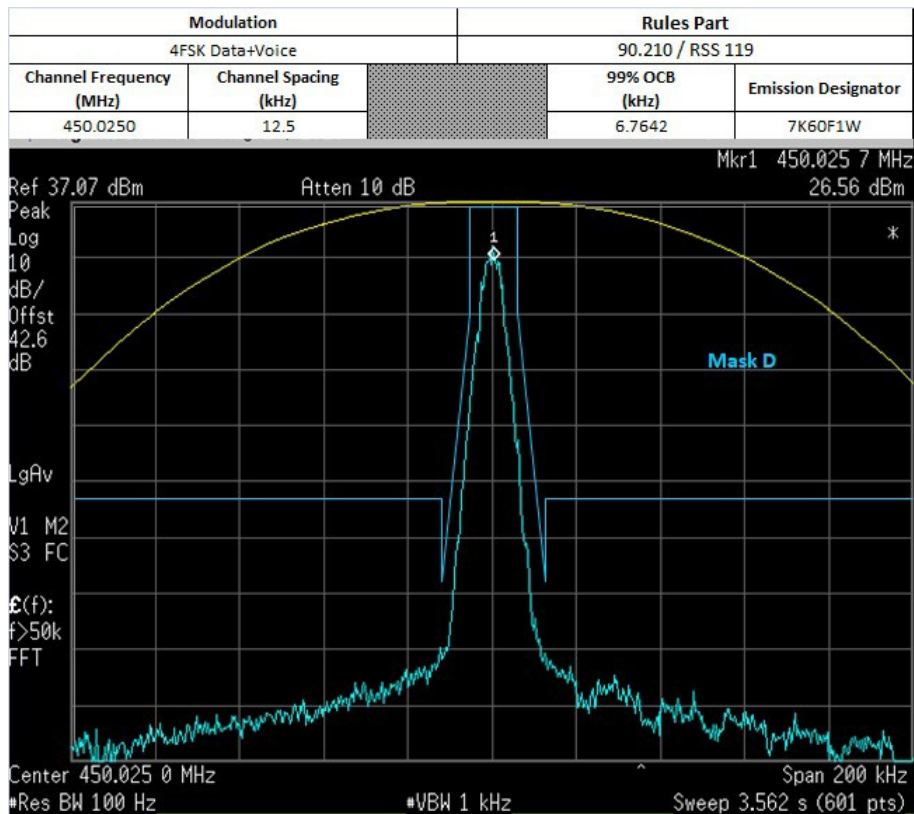

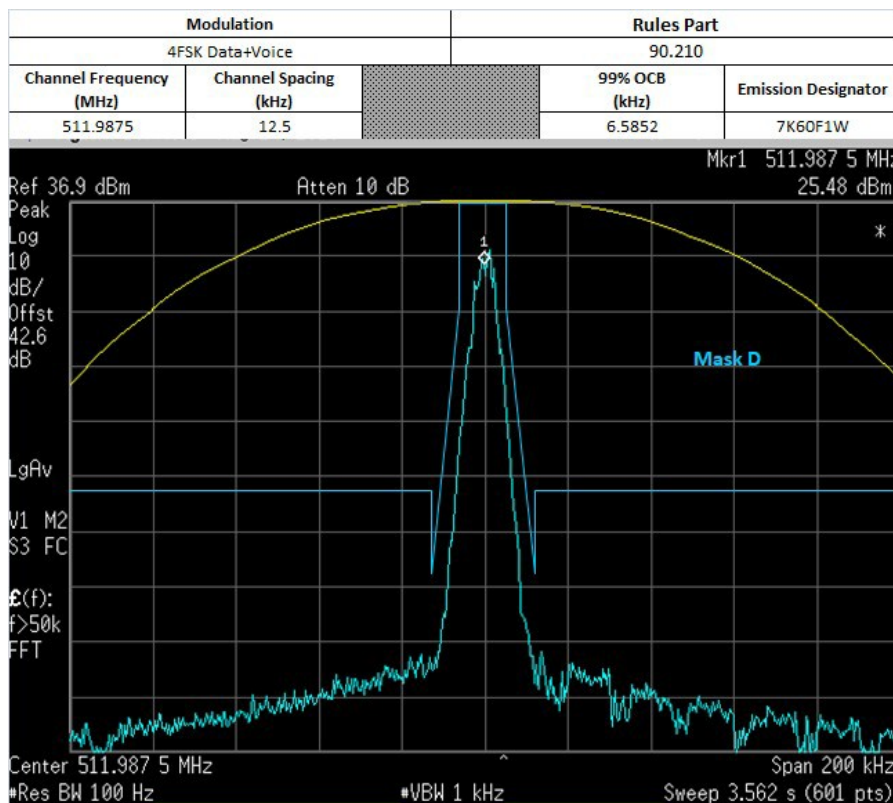

Not for FCC review

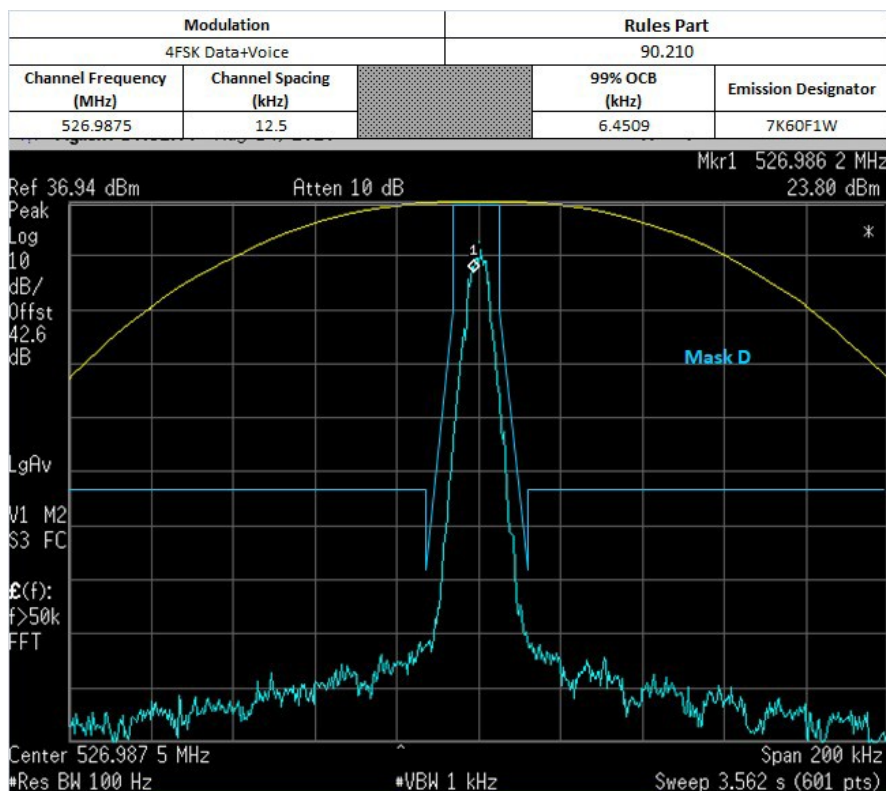

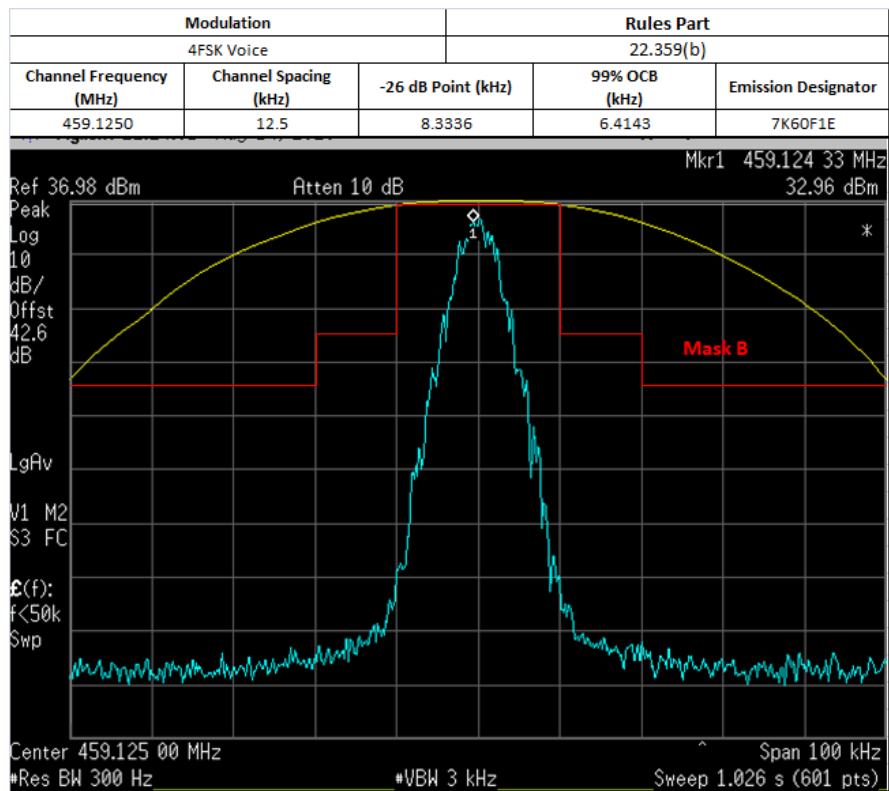
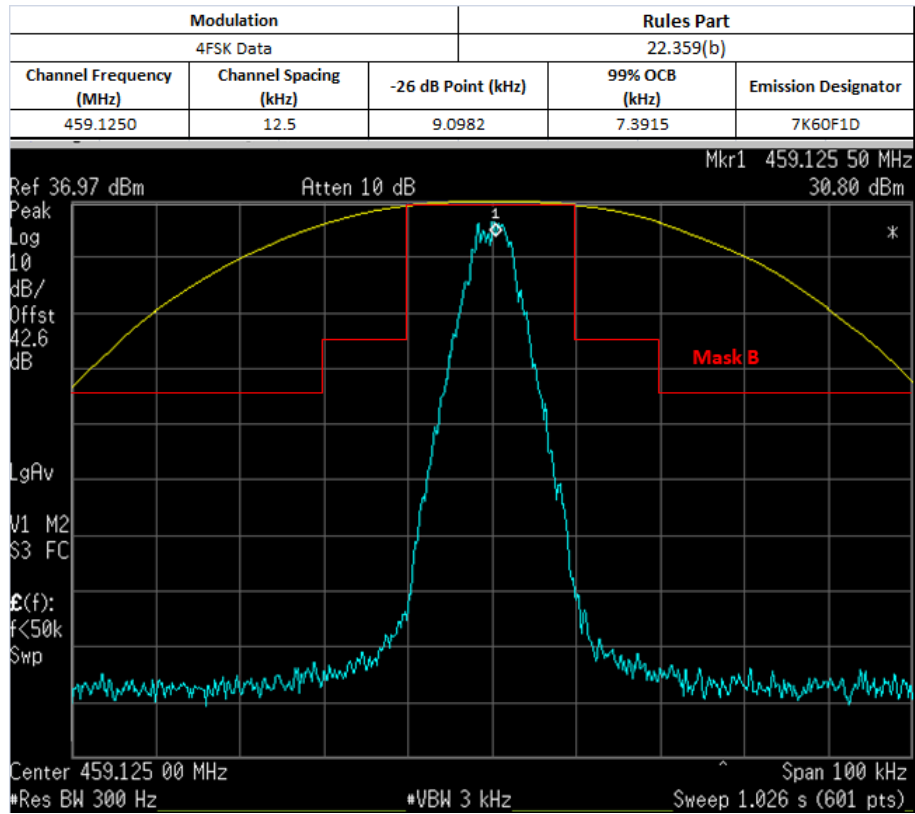

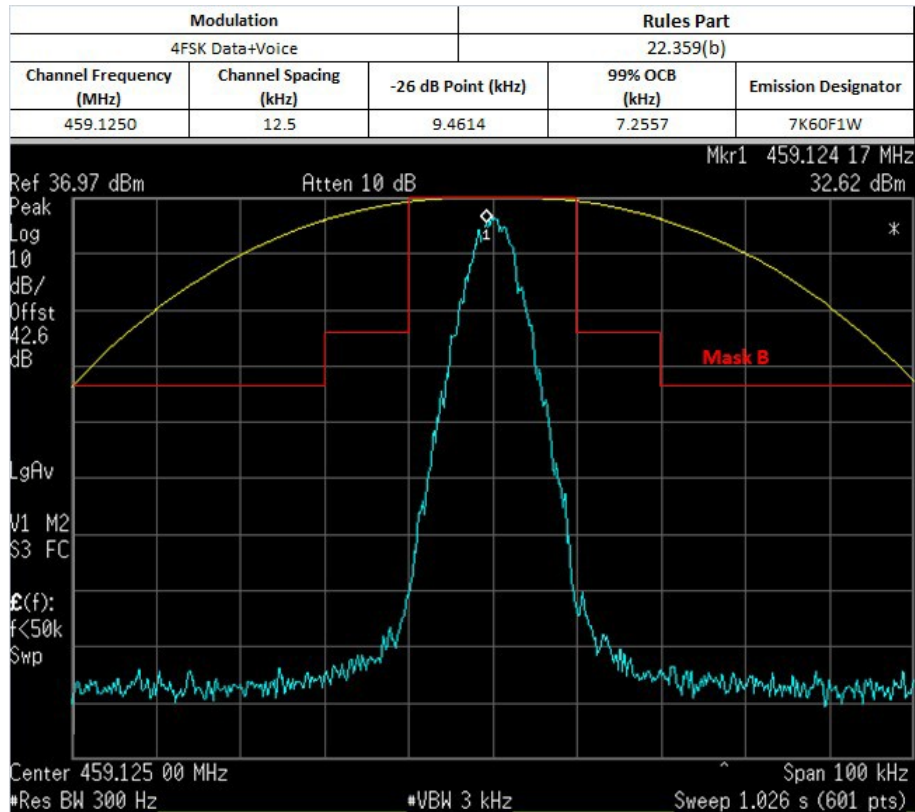

6.6.5. Test Limit

The 99% occupied bandwidth is the width of a frequency band such that, below the lower and above the upper frequency limits, the mean powers emitted are each equal to a specified percentage 0.5% of the total mean transmitted power.

6.7. Band Edge Conducted Spurious Emission (Part 22)

6.7.1. Test Setup (Analog)

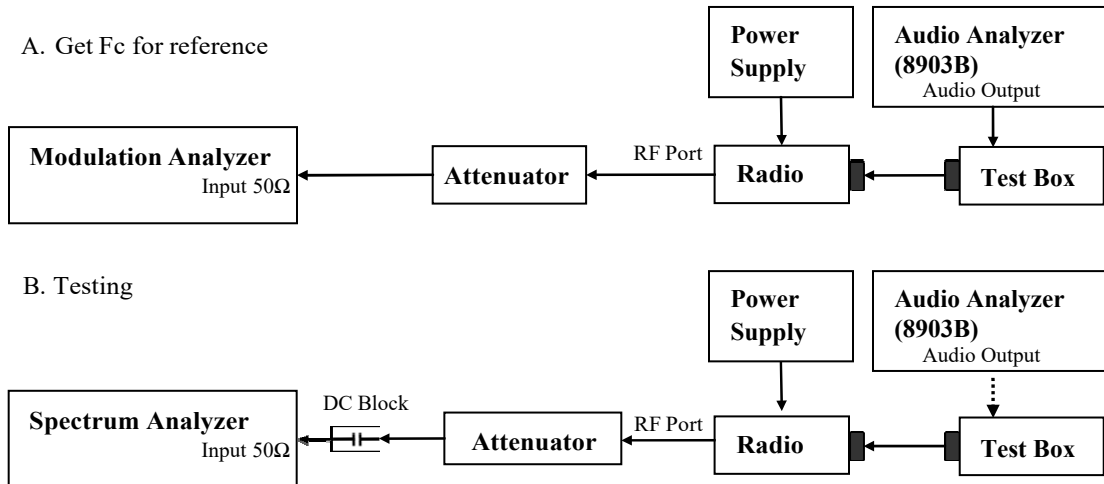

- 1) The DUT transmitter output port was connected to Modulation Analyzer.
- 2) Set the audio bandwidth filter to 15 kHz low pass filter and 50 kHz high pass filter.
- 3) Transmit the radio and set the audio analyzer to 2.5 kHz audio frequency and 50% of the rated deviation. Up the amplitude by 16 dB. Dekey the DUT.
- 4) Path loss for the measurement included.
- 5) Select the Occupied Bandwidth measurement for 99% and 26dB Emissions Bandwidth Measurement.
- 6) Key in the Fc and Resolution Bandwidth.
- 7) Transmit the DUT and record the occupied Bandwidth frequencies.
- 8) Preset the spectrum analyzer for band edge measurement.
- 9) The band edges of lowest and highest channels were measured.
- 10) Key in the Lowest and highest channel frequency, span is 60 kHz and Resolution Bandwidth is at least 1% of Emission Bandwidth.
- 11) Save the screen shot as modulated signal.
- 12) Remove the audio tone from audio analyzer to capture unmodulated signal.

*Note:

- For emission designator ending with F3E, 16K0F3E is the worst case and therefore only 16K0F3E will be shown.

6.7.2. Test Result (Analog)

MAX POWER

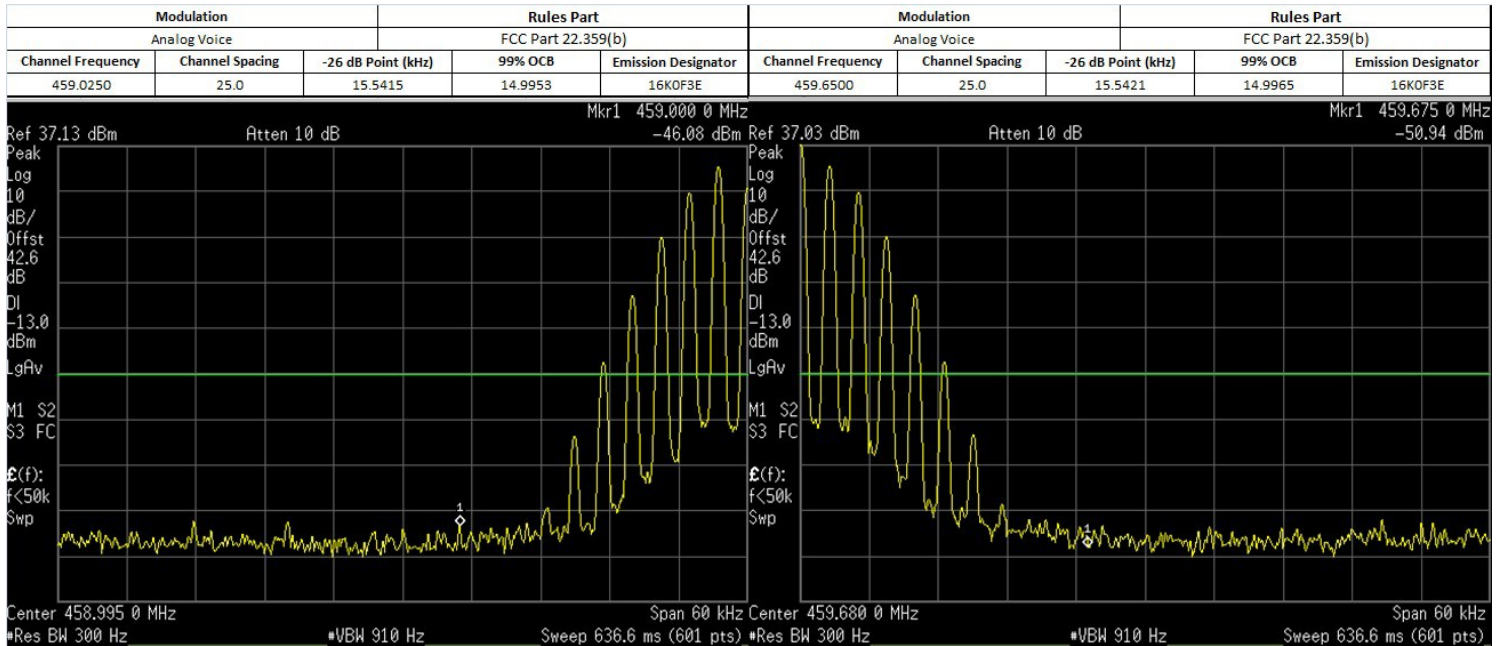

MAX POWER

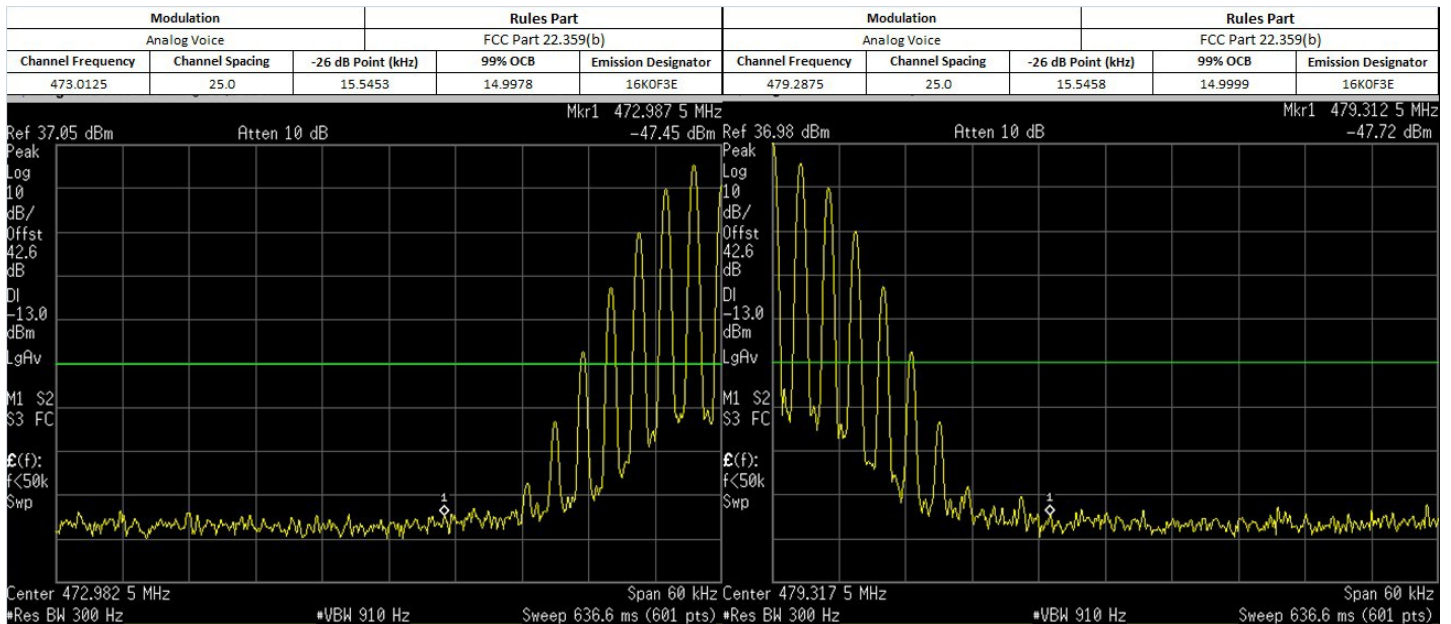

6.7.3. Test Setup (Digital)

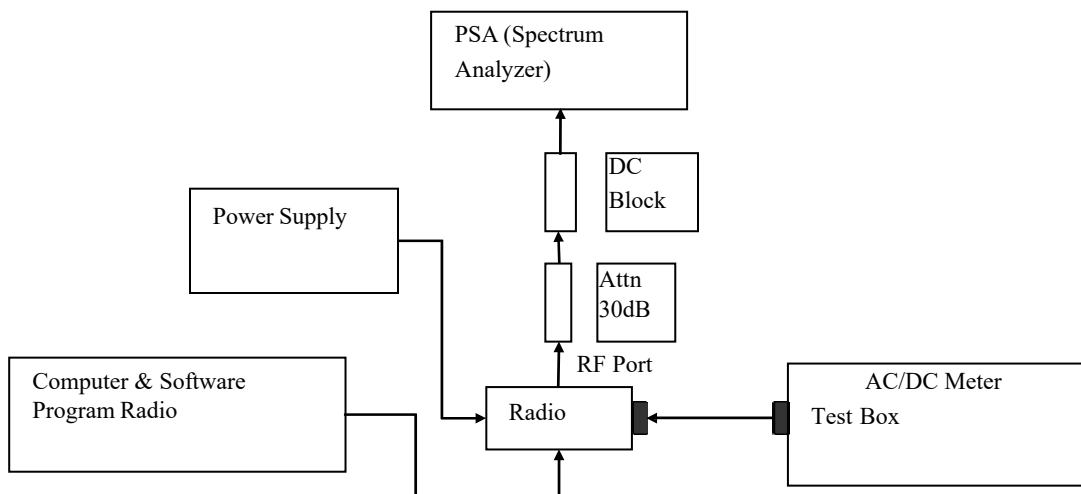

- 1) Program and set radio to operate in desire test frequency and digital mode with modulation. (*4FSK, C4FM or other digital modulation form).
- 2) Path loss for the measurement included.
- 3) Select the Occupied Bandwidth measurement for 99% and 26dB Emissions Bandwidth Measurement.
- 4) Key in the Fc and Resolution Bandwidth.
- 5) Transmit radio record the occupied Bandwidth frequencies.
- 6) Preset the spectrum analyzer for band edge measurement.
- 7) Key in the lowest and highest channels frequency, span is 60 kHz and Resolution Bandwidth is at least 1% of Emission Bandwidth.
- 8) Save the screen shot.

*Note:

- For Digital Modulation, 12.5 kHz Data F1D & FXD would be the same. Therefore only measurements with F1D modulation shown below.
- For Digital Modulation, 12.5 kHz Data F1E & FXE would be the same. Therefore only measurements with F1E modulation shown below.