



|   |   |
|---|---|
|    |  <p>MS ISO/IEC 17025<br/>TESTING<br/>SAMM No. 0825</p> |
| <p><b>MOTOROLA PENANG ADV. COMM. LABORATORY</b><br/>Motorola Solutions Malaysia Sdn Bhd<br/>Innoplex Plot 2A, Medan Bayan Lepas,<br/>Mukim 12 S.W.D, 11900 Bayan Lepas,<br/>Penang, Malaysia.</p>   | <p><b>FCC / ISED TEST REPORT</b><br/><b>Report Revision : Rev.A</b></p>   |
| <p><b>Date/s Tested</b> : 19-SEP-2017 - 2-OCT-2017<br/><b>Report Issue Date</b> : 05-JAN-2018<br/><b>Manufacturer/Location</b> : Motorola Solutions Malaysia Sdn Bhd<br/><b>Requestor</b> : ANG BOON CHYE<br/><b>Product Type</b> : Portable<br/><b>Model Number</b> : CLU1060BBLBA<br/><b>Frequency Band</b> : 450-470 MHz<br/><b>Low / Max RF Output Power</b> : 1.2 Watts<br/><b>Applicant Name</b> : Motorola Solutions Malaysia Sdn Bhd<br/><b>Applicant Address</b> : Innoplex Plot 2A, Medan Bayan Lepas,<br/>Mukim 12 S.W.D, 11900 Bayan Lepas,<br/>Penang, Malaysia<br/><b>FCC Test Firm Registration</b> : 461337</p> <p><b>The equipment was tested accordance to the requirement listed below:</b></p> <p>(LMR)<br/><b>FCC 47 CFR Part 90</b> <b>PASS</b><br/><b>ISED RSS- Gen / 119</b></p>  |   |
| <p>This report shall not be reproduced without written approval from an officially designated representative of the Motorola Penang Adv. Comm. Laboratory. The results and statements contained in this report pertain only to the device(s) evaluated.</p>   |   |
| <p>Prepared By:</p><br><br><hr/> <p><b>Song Zhi Wei</b><br/><b>Test Personnel</b></p>   | <p>Approved By:</p><br><br><hr/> <p><b>Vincent Foong</b><br/><b>Responsible Engineer</b></p>  |

# Table of Contents

|  |    |
|--|----|
| Report Revision History .....                              | 3  |
| 1.0 General Information.....                               | 4  |
| 2.0 Summary of Test Results .....                          | 5  |
| 3.0 Measurement Uncertainty .....                          | 5  |
| 4.0 Equipment List.....                                    | 6  |
| 5.0 Test Condition.....                                    | 7  |
| 5.1. Transmitter Test Conditions .....                     | 7  |
| 6.0 Transmitter Test Parameters .....                      | 8  |
| 6.1. RF Output Power .....                                 | 8  |
| 6.1.1. Test Setup.....                                     | 8  |
| 6.1.2. Test Result .....                                   | 8  |
| 6.2. Frequency Stability .....                             | 9  |
| 6.2.1. Test Setup.....                                     | 9  |
| 6.2.2. Test Result .....                                   | 10 |
| 6.2.3. Test Limit.....                                     | 11 |
| 6.3. Audio Frequency Response .....                        | 12 |
| 6.3.1. Test Setup.....                                     | 12 |
| 6.3.2. Test Result .....                                   | 13 |
| 6.3.3. Test Limit.....                                     | 14 |
| 6.4. Audio Low Pass Filter Response .....                  | 15 |
| 6.4.1. Test Setup.....                                     | 15 |
| 6.4.2. Test Result .....                                   | 15 |
| 6.4.3. Test Limit.....                                     | 16 |
| 6.5. Modulation Limiting .....                             | 17 |
| 6.5.1. Test Setup.....                                     | 17 |
| 6.5.2. Test Result .....                                   | 18 |
| 6.5.3. Test Limit.....                                     | 18 |
| 6.6. Occupied Bandwidth.....                               | 19 |
| 6.6.1. Test Setup (Analog) .....                           | 19 |
| 6.6.2. Test Result (Analog).....                           | 20 |
| 6.6.3. Test Setup (Digital).....                           | 22 |
| 6.6.4. Test Result (Digital).....                          | 22 |
| 6.6.5. Test Limit.....                                     | 22 |
| 6.7. Band Edge Conducted Spurious Emission (Part 22) ..... | 23 |
| 6.7.1. Test Setup (Analog) .....                           | 23 |
| 6.7.2. Test Result (Analog).....                           | 23 |
| 6.7.3. Test Setup (Digital).....                           | 24 |
| 6.7.4. Test Result (Digital).....                          | 24 |
| 6.7.5. Test Limit.....                                     | 24 |
| 6.8. Transient Frequency Behavior .....                    | 25 |
| 6.8.1. Test Setup.....                                     | 25 |
| 6.8.2. Test Result .....                                   | 26 |
| 6.8.3. Test Limit.....                                     | 28 |

6.9. Adjacent Channel Power..... 29

6.9.1. Test Setup (Analog) ..... 29

6.9.2. Test Result ..... 29

6.9.3. Test Setup (Digital)..... 30

6.9.4. Test Result ..... 30

6.9.5. Test Limit..... 31

6.10. Conducted Spurious Emission ..... 33

6.10.1. Test Setup..... 33

6.10.2. Test Result (Analog)..... 34

6.10.3. Test Result (Digital)..... 39

6.10.4. Test Limit..... 39

6.11. Radiated Spurious Emission ..... 40

6.11.1. Test Setup..... 40

6.11.2. Test Result (Analog)..... 41

6.11.3. Test Result (Digital)..... 41

6.11.4. Test Limit..... 41

6.12. Effective Radiated Power (ERP) ..... 42

6.12.1. Test Setup..... 42

6.12.2. Test Result ..... 43

6.12.3. Test Limit..... 43

6.13. GNSS (EIRP for 1559 - 1610MHz)..... 43

6.13.1. Test Setup..... 43

6.13.1. Test Result ..... 44

6.13.2. Test Limit..... 44

**Report Revision History**

| <b>Revision History</b> | <b>Description</b> | <b>Date</b> | <b>Originator</b> |
|-------------------------|--------------------|-------------|-------------------|
| Rev. A                  | Initial Report     | 05-JAN-2018 | Song Zhi Wei      |

## 1.0 General Information

### EUT Description:

|                        |                         |
|------------------------|-------------------------|
| <b>Technologies</b>    | Land Mobile Radio (LMR) |
| <b>Modulation Type</b> | Analog                  |

### General Description of Applied Standards

The EUT is a RF Product. According to the specifications of the manufacturer, the EUT is to comply with the requirements of the following standards:

**ANSI/TIA/-603-D**  
**ANSI C63.4-2014**  
**ANSI C63.26-2015**

## 2.0 Summary of Test Results

| FCC General Rules Part (47CFR) | ISED General Rules Part | Test Item                             | Result | Remark                                    |
|--------------------------------|-------------------------|---------------------------------------|--------|---|
| 2.1046, 90.210                 | RSS-Gen, RSS-119        | RF Power Output                       | Pass   | NA  |
| 90.214                         | -                       | Frequency Stability                   | Pass   | NA  |
| 2.1047                         | -                       | Audio Frequency Response              | Pass   | NA  |
| -                              | -                       | Audio Low Pass Filter Response        | NA     | NA  |
| 2.1047                         | RSS-Gen, RSS-119        | Modulation limiting                   | Pass   | NA  |
| 2.1049, 90.210                 | RSS-Gen, RSS-119        | Occupied Bandwidth                    | Pass   | 11K0F3E- 9.6990kHz<br>16K0F3E- 14.9572kHz |
| -                              | -                       | Band Edge Conducted Spurious Emission | NA     | NA  |
| 90.214                         | -                       | Transient Frequency Behavior          | Pass   | NA  |
| -                              | -                       | Adjacent Channel Power                | NA     | NA  |
| 2.1051, 90.210                 | RSS-Gen, RSS-119        | Conducted Spurious Emissions          | Pass   | Highest Spur Level<br>-43.48dBm           |
| -                              | -                       | Radiated Spurious Emission            | NA     | Refer External Lab Report                 |
| -                              | -                       | GNSS (EIRP for 1559 – 1610MHz)        | NA     | NA  |
| -                              | -                       | Effective Radiated Power (ERP)        | NA     | Refer External Lab Report                 |

NA → Not Applicable

## 3.0 Measurement Uncertainty

| Measurement                               | Frequency        | Expanded Uncertainty (k=1.96) (±) |
|---|------------------|-----------------------------------|
| AC Power Line Conducted Spurious Emission | 150KHz ~ 30MHz   | 3.43                              |
| Radiated Emissions up to 1 GHz            | 30MHz ~ 200MHz   | 5.01                              |
|   | 200MHz ~ 1000MHz | 5.01                              |
| Radiated Emissions above 1 GHz            | 1GHz ~ 18GHz     | 5.01                              |
|   | 18GHz ~ 25GHz    | 5.01                              |

#### 4.0 Equipment List

##### FCC Analog ATE#1: (SW version: 2.4.3& FCC\_FreqStability\_Rev 1.0.3)

| Description           | Model      | Serial Number | Calibration Date | Calibration Due Date |
|-----------------------|------------|---------------|------------------|----------------------|
| Audio Analyzer        | 8903B      | 3011A10475    | 2-May-17         | 2-May-18             |
| SIGNAL GENERATOR      | 2042       | 203002/745    | 2-May-17         | 2-May-18             |
| MODULATION ANALYZER   | 8901B      | 3216A03889    | 3-May-17         | 3-May-18             |
| TRANSCEIVER INTERFACE | 8954A      | 2234A00398    | 4-May-17         | 4-May-18             |
| DSA                   | 36570A     | MY42506781    | 3-May-17         | 3-May-18             |
| SIGNAL GENERATOR      | E4424B     | MY43350219    | 24-Mar-17        | 24-Mar-18            |
| SIGNAL GENERATOR      | 119861/041 | 119861/041    | 7-Feb-17         | 7-Feb-18             |
| POWER SENSOR          | E4412A     | MY41502652    | 9-May-17         | 9-May-18             |
| POWER METER           | E4416A     | GB41293855    | 9-May-17         | 9-May-18             |
| POWER SUPPLY          | 6031A      | 3325A02771    | 3-Mar-17         | 3-Mar-18             |
| CHAMBER               | SH-641     | 92014678      | 4-Apr-17         | 3-Apr-18             |

##### FCC Transient ATE #1: (SW version: FCC Transient ATE\_R1.0.3)

| Description               | Model    | Serial Number | Calibration Date | Calibration Due Date |
|---------------------------|----------|---------------|------------------|----------------------|
| POWER SUPPLY              | 6032A    | 2818A03549    | 11-May-17        | 11-May-18            |
| POWER SENSOR              | E4412A   | MY41498918    | 9-May-17         | 9-May-18             |
| POWER METER               | E4416A   | MY45101016    | 11-Jan-17        | 11-Jan-18            |
| ATTENUATORS/SWITCH DRIVER | 11713A   | 2508A10141    | CNR              | CNR                  |
| STEP ATTENUATOR/11dB      | 8494G    | MY52300223    | 9-May-17         | 9-May-18             |
| STEP ATTENUATOR/110dB     | 8496G    | MY52300176    | 9-May-17         | 9-May-18             |
| OSCILLOSCOPE              | MSO8064A | MY48240107    | 25-May-17        | 25-May-18            |
| AUDIO ANALYZER            | 8903B    | 3729A17409    | 2-May-17         | 2-May-18             |
| AUDIO ANALYZER            | 8903B    | 3011A08952    | 2-May-17         | 2-May-18             |
| MODULATION ANALYZER       | 8901B    | 3019A02766    | 4-Mar-17         | 4-Mar-18             |
| SIGNAL GENERATOR          | 8657A    | 3323A05725    | 2-May-17         | 2-May-18             |
| SPECTRUM ANALYZER         | E4440A   | MY46185415    | 24-May-17        | 24-May-19            |
| SWITCH CONTROL UNIT       | -        | -             | CNR              | CNR                  |

##### CONDUCTED SPUR EMISSION ATE # 1 (SW version: 1.23.01)

| Description                 | Model  | Serial Number | Calibration Date | Calibration Due Date |
|-----------------------------|--------|---------------|------------------|----------------------|
| SWITCH CONTROL UNIT         | 3488A  | 2719A32735    | CNR              | CNR                  |
| SPECTRUM ANALYZER           | E4440A | US45303111    | 16-Feb-17        | 16-Feb-18            |
| POWER SUPPLY                | 6032A  | MY41002067    | 5-May-17         | 5-May-18             |
| HIGH PASS FILTER SWITCH BOX | -      | CS001         | 7-Apr-17         | 7-Apr-18             |
| MICROWAVE GENERATOR         | SMP 02 | 830682/015    | 19-Oct-16        | 19-Oct-17            |
| MODULATION ANALYZER         | 8901B  | 3438A05278    | 3-Mar-17         | 3-Mar-18             |

**CNR → Calibration Not Required**

## 5.0 Test Condition

### 5.1 Transmitter Test Conditions

| Test Item,<br>(Channel Spacing)   | Power<br>(W) | Modulation | Test Frequency<br>(MHz)          | Tested By    |
|---|--------------|------------|----------------------------------|--------------|
| RF Output Power   | Low & Max    | Analog     | 451.1875, 461.0375 ,<br>469.5625 | Song Zhi Wei |
| Frequency Stability   | Max          | Analog     | 469.5625                         | Song Zhi Wei |
| Audio Frequency Response<br>(12.5kHz / 25kHz)                                 | Max          | Analog     | 469.5625                         | Song Zhi Wei |
| Audio Low Pass Filter Response<br>(12.5kHz / 25kHz)                           | Max          | Analog     | NA                               | NA           |
| Modulation limiting<br>(12.5kHz / 25kHz)                                      | Max          | Analog     | 469.5625                         | Song Zhi Wei |
| Occupied Bandwidth<br>(12.5kHz / 25kHz)                                       | Max          | Analog     | 451.1875,469.5625                | Song Zhi Wei |
| Band Edge Conducted Spurious Emissions (Part 22)<br>(12.5kHz / 20kHz / 25kHz) | Max          | Analog     | NA                               | NA           |
| Transient Frequency Behavior<br>(UHF & VHF Band)<br>(12.5kHz / 25kHz)         | Max          | Analog     | NA                               | NA           |
| Adjacent Channel Power<br>(700MHz Band)<br>(12.5kHz / 25kHz)                  | Max          | Analog     | NA                               | NA           |
| Conducted Spurious Emissions<br>(12.5kHz / 25kHz)                             | Low / Max    | Analog     | 451.1875, 461.0375 ,<br>469.5625 | Song Zhi Wei |
| Radiated Spurious Emission<br>(12.5kHz / 25kHz)                               | Low / Max    | Analog     | NA                               | NA           |
| GNSS (EIRP for 1559 - 1610MHz)<br>(12.5kHz / 25kHz)                           | Max          | Analog     | NA                               | NA           |
| Effective Radiated Power (ERP)<br>(12.5kHz / 25kHz)                           | Max          | Analog     | NA                               | NA           |

NA → Not Applicable

## 6.0 Transmitter Test Parameters

### 6.1 RF Output Power

#### 6.1.1 Test Setup

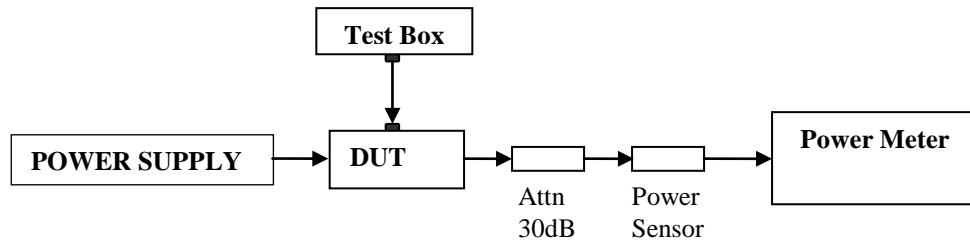

- 1) The DUT transmitter connected to Power Meter using the 30 dB attenuator and power sensor with above setup.
- 2) Path loss for the measurement included.
- 3) All the measurement was done at low, mid, high frequency for each band.
- 4) Record the power into the test report.

#### 6.1.2 Test Result

|                 |               |             |         |
|-----------------|---------------|-------------|---------|
| Temperature     | 25°C          |             | Remarks |
| Voltage (V)     | 3.7V          |             |         |
| Frequency (MHz) | Max Power (W) | Current (A) |         |
| 451.1875        | 1.13          | 0.87        |         |
| 461.0375        | 1.10          | 0.83        |         |
| 469.5625        | 1.08          | 0.81        |         |



## 6.2. Frequency Stability

### 6.2.1. Test Setup

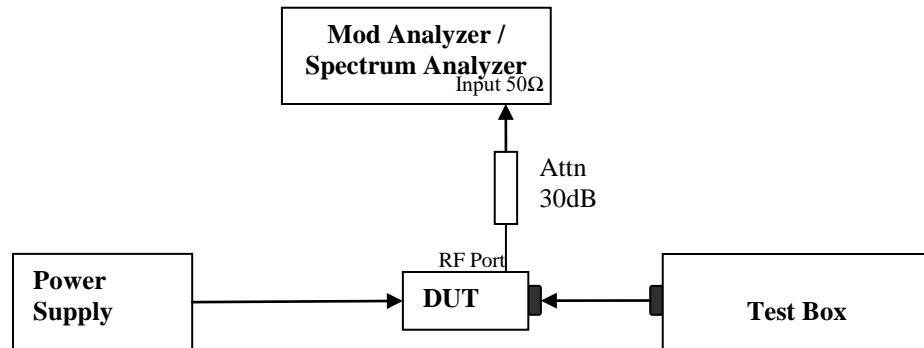

- 1) The DUT transmitter output port was connected to Modulation / Spectrum Analyzer.
- 2) Path loss for the measurement included.
- 3) Transmit the DUT and record the freq in  $MCF_{MHz}$ .
- 4) Test in 2 conditions:
  - Temperature: The frequency of the transmitter was measured from  $-30^{\circ}C$  to  $50^{\circ}C$ .
  - Supply Voltage:
    - Mobile: The frequency of the transmitter was measured from 85% to 115% of the nominal operating input voltage.
    - Portable: The frequency of the transmitter was measured from nominal  $\pm x\%$  as specified by the manufacturer
- 5) Calculate the ppm frequency error by the following:

$$ppm\ error = \left( \frac{MCF_{MHz}}{ACF_{MHz}} - 1 \right) * 10^6$$

Where:  $MCF_{MHz}$  is the Measured Carrier Frequency in MHz  
 $ACF_{MHz}$  is the Assigned Carrier Frequency in MHz

### 6.2.2. Test Result

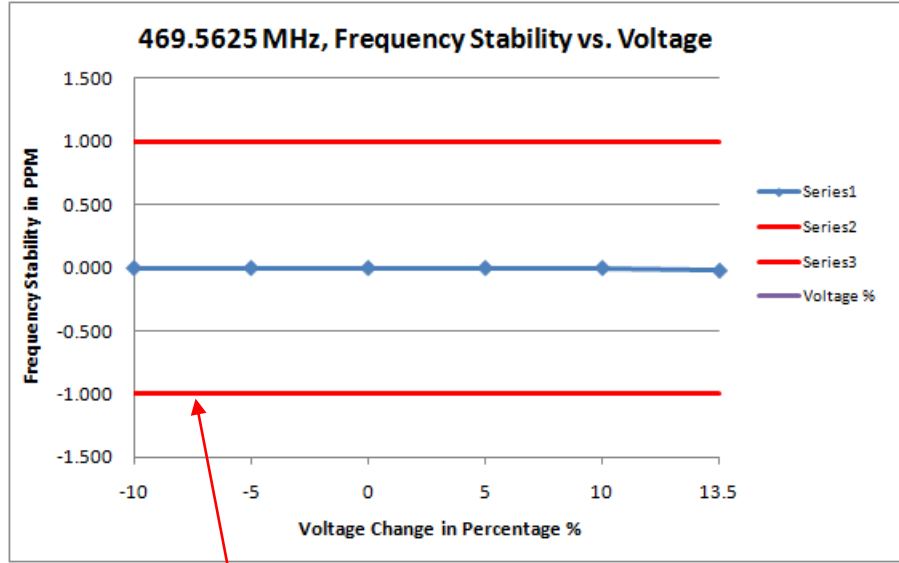

Manufacturer specified battery operating end point

(i) Frequency Stability VS Voltage

| Frequency / Channel Spacing |            | 469.5625 MHz / 12.5 kHz |                          |                |                 |
|-----------------------------|------------|-------------------------|--------------------------|----------------|-----------------|
| Temperature, °C             |            | 25                      |                          |                |                 |
| Voltage %                   | Voltage, V | Frequency, MHz          | Frequency Stability, PPM | Spec (low) PPM | Spec (high) PPM |
| -10                         | 3.330      | 469.562500              | 0.000                    | -1.000         | 1.000           |
| -5                          | 3.515      | 469.562500              | 0.000                    | -1.000         | 1.000           |
| 0                           | 3.700      | 469.562490              | 0.000                    | -1.000         | 1.000           |
| 5                           | 3.885      | 469.562500              | 0.000                    | -1.000         | 1.000           |
| 10                          | 4.070      | 469.562500              | 0.000                    | -1.000         | 1.000           |
| 13.5                        | 4.200      | 469.562490              | -0.021                   | -1.000         | 1.000           |

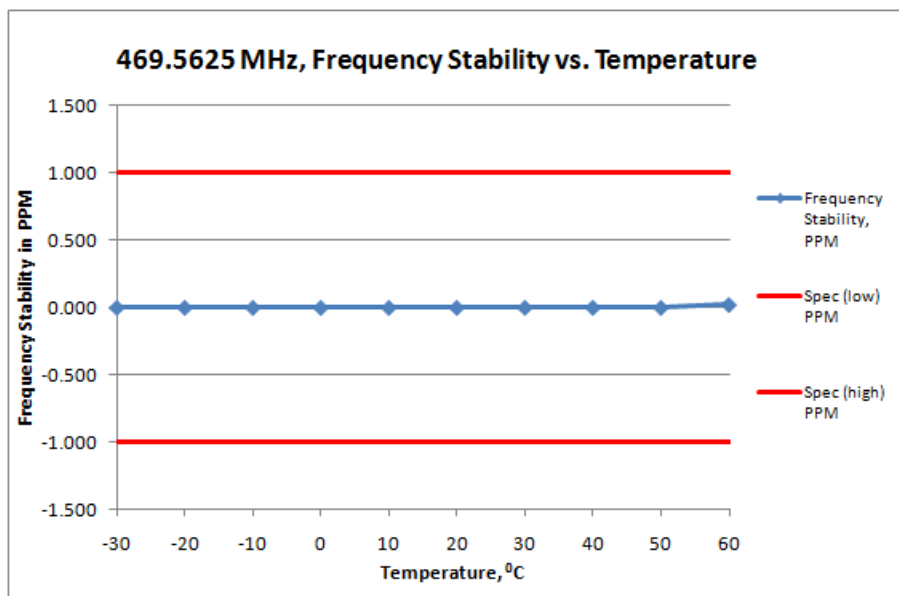

(ii) Frequency Stability VS temperature

| Frequency / Channel Spacing | 469.5625 MHz / 12.5 kHz |                          |                |                 |
|-----------------------------|-------------------------|--------------------------|----------------|-----------------|
| Voltage, V                  | 3.7                     |                          |                |                 |
| Temperature, °C             | Frequency, MHz          | Frequency Stability, PPM | Spec (low) PPM | Spec (high) PPM |
| -30                         | 469.562500              | 0.000                    | -1.000         | 1.000           |
| -20                         | 469.562500              | 0.000                    | -1.000         | 1.000           |
| -10                         | 469.562500              | 0.000                    | -1.000         | 1.000           |
| 0                           | 469.562500              | 0.000                    | -1.000         | 1.000           |
| 10                          | 469.562500              | 0.000                    | -1.000         | 1.000           |
| 20                          | 469.562500              | 0.000                    | -1.000         | 1.000           |
| 30                          | 469.562500              | 0.000                    | -1.000         | 1.000           |
| 40                          | 469.562500              | 0.000                    | -1.000         | 1.000           |
| 50                          | 469.562500              | 0.000                    | -1.000         | 1.000           |
| 60                          | 469.562510              | 0.021                    | -1.000         | 1.000           |

**6.2.3. Test Limit**

As per manufacturer declared spec +/- 1ppm

### 6.3. Audio Frequency Response

#### 6.3.1. Test Setup

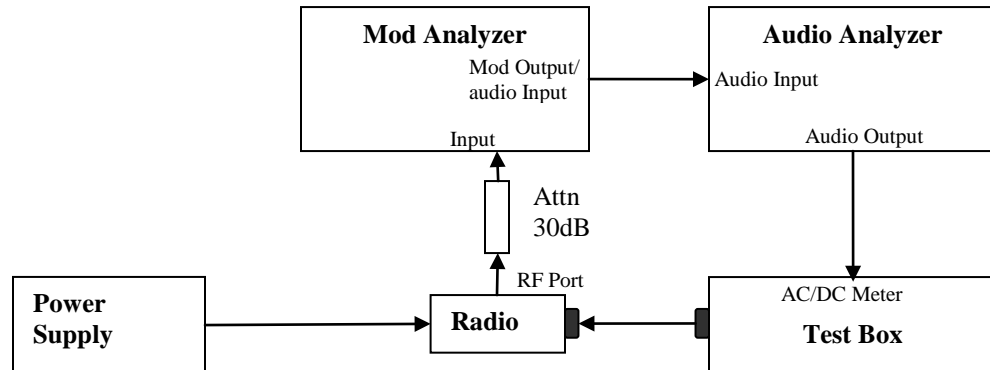

- 1) The DUT transmitter output port was connected to Modulation Analyzer.
- 2) Path loss for the measurement included.
- 3) Set the audio bandwidth filter to 15 kHz and 50 kHz.
- 4) Transmit the radio and set the audio analyzer to 1 kHz audio frequency and 20% of the Full rated system deviation.
- 5) On audio analyzer, set the rated level as reference to zero.
- 6) Vary the audio frequency from 300 Hz to 3 kHz. Record the change in dB on the audio analyzer.

### 6.3.2. Test Result

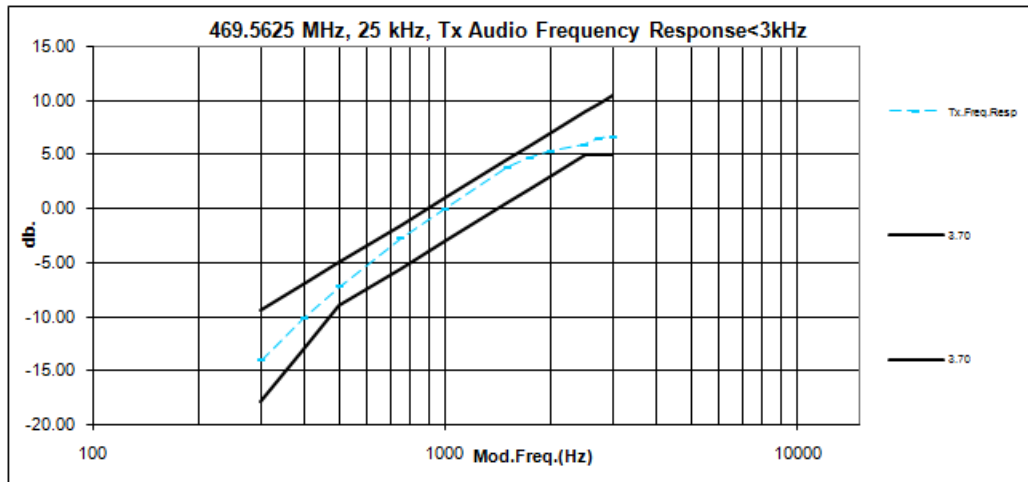
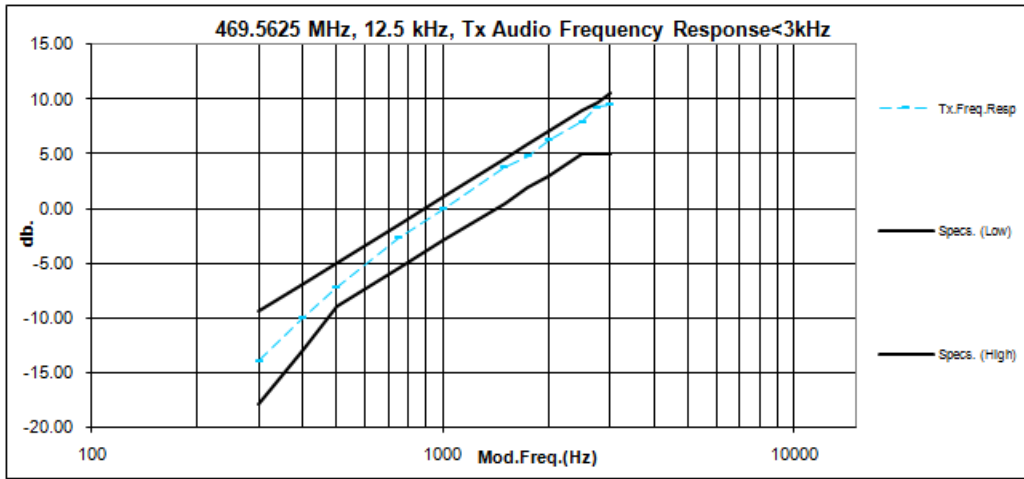

NOT FOR FCC REVIEW

### 6.3.3. Test Limit

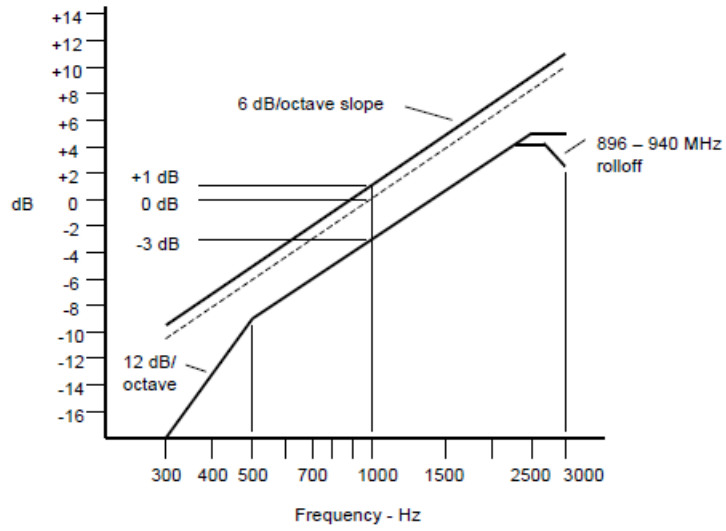

Note:

- o There are additional 6 dB per octave attenuation is allowed from 2.5KHz to 3KHz in equipment 25MHz to 869MHz radio.
- o Additional 6 dB per octave attenuation is allowed from 2.3KHz to 2.7KHz & additional 12 dB per octave attenuation is allowed from 2.7KHz to 3KHz in equipment 896MHz to 940MHz radio.

## 6.4. Audio Low Pass Filter Response

### 6.4.1. Test Setup

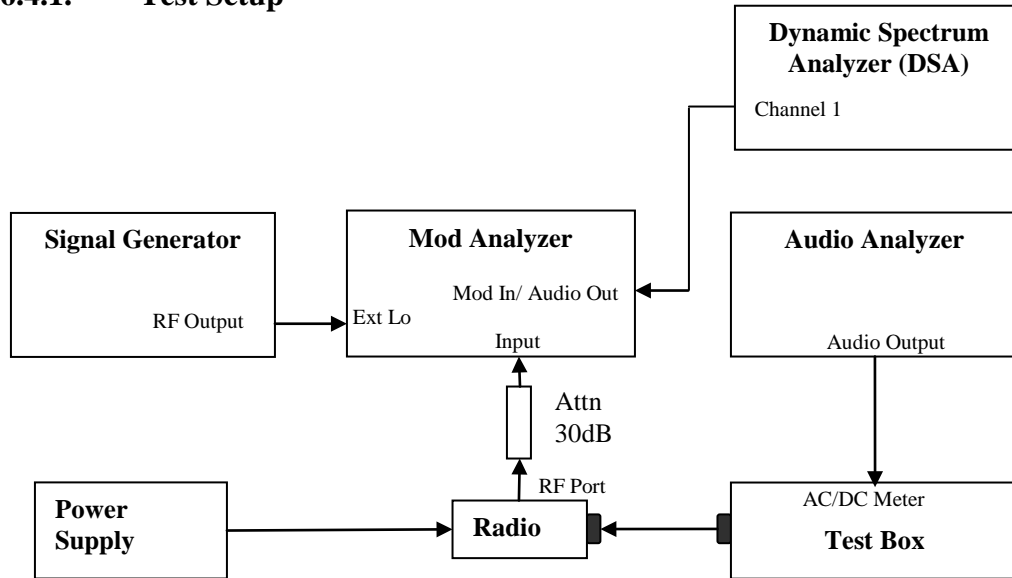

- 1) The DUT transmitter output port was connected to Modulation Analyzer.
- 2) Path loss for the measurement included.
- 3) Press 23.1SPCL on modulation analyzer to enable the external LO from Sigen.
- 4) Set the Sigen frequency to  $F_c + 1.5$  MHz, RF output level to 0dBm without modulation.
- 5) Transmit the radio and set the audio analyzer to 1 kHz audio frequency and 60% of the Full rated system deviation.
- 6) Up the amplitude by 20dB.
- 7) On DSA, get the reference point to 0dB.
- 8) Vary the frequency on audio analyzer from 3 kHz to 20 kHz, record the audio tone from DSA.

### 6.4.2. Test Result

NA → Not Applicable

### 6.4.3. Test Limit

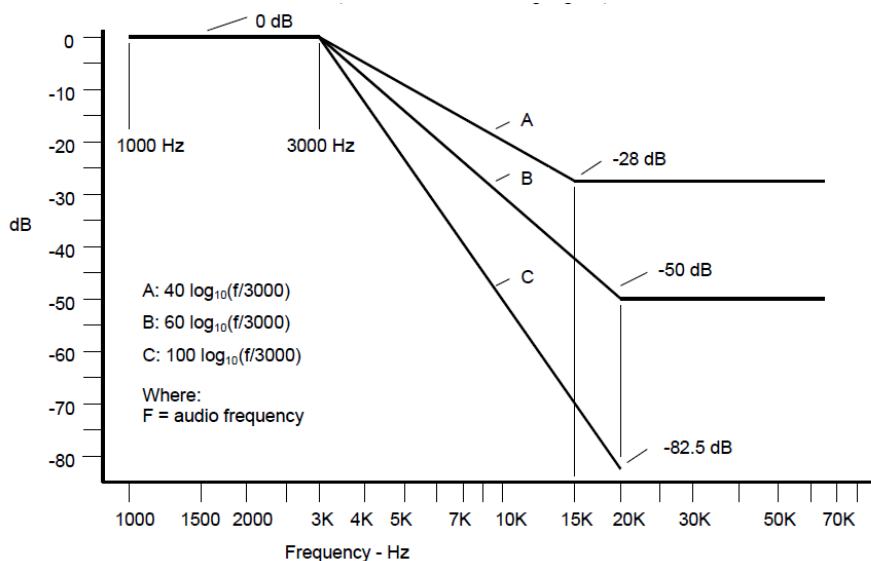

For audio frequencies above 3000 Hz, the audio response of the post limiter low-pass filter shall meet or exceed the following requirements:

- a) For equipment operating on 20, 25 or 30 kHz channel bandwidth in the 25 MHz to 174 MHz range:

At frequencies from 3000 Hz through 15,000 Hz the attenuation shall be greater than the attenuation at 1000 Hz by at least:  $40 \log_{10}(f/3000)$  dB

where:  $f$  is the audio frequency in Hz.

At frequencies above 15,000 Hz, the attenuation shall be greater than the attenuation at 1000 Hz, by at least: 28 dB.

- b) For equipment operating with 25 kHz bandwidth channels between 406 and 512 MHz through 896 MHz, and between 929 MHz through 930 MHz:

At frequencies from 3000 Hz through 20,000 Hz, the attenuation shall be greater than the attenuation at 1000 Hz by at least:  $60 \log_{10}(f/3000)$  dB

where:  $f$  is the audio frequency in Hz.

At frequencies above 20,000 Hz the attenuation shall be greater than the attenuation at 1000 Hz by at least: 50 dB.

- c) For equipment operating on channels between 896 MHz through 901 MHz, between 935 MHz through 940 MHz, and 12.5 or 15 kHz spaced channels in the frequency range 138-174 MHz and 406-512 MHz.

At frequencies from 3000 Hz through 20,000 Hz the attenuation shall be greater than the attenuation at 1000 Hz by at least:  $100 \log_{10}(f/3000)$  dB

where:  $f$  is the audio frequency in Hz.



## 6.5. Modulation Limiting

### 6.5.1. Test Setup

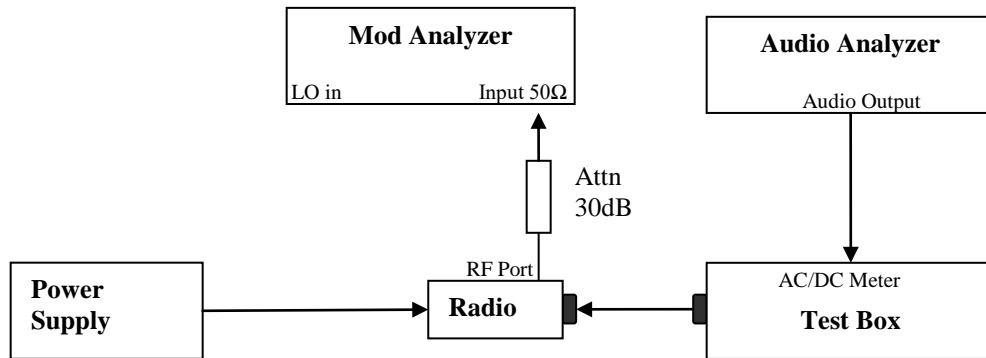

- 1) The DUT transmitter output port was connected to Modulation Analyzer.
- 2) Path loss for the measurement included.
- 3) Set the audio bandwidth filter to 15 kHz.
- 4) Transmit the radio and set the audio analyzer to 1 kHz audio frequency and 60% of the Full rated system deviation.
- 5) Record the frequency deviation as 0dB input level at 1kHz audio frequency.
- 6) Repeat the step and record the frequency deviation from -20 dB to 20dB by 5 dB increments and different audio freq 300 Hz, 2.5 kHz and 3 kHz.

### 6.5.2. Test Result

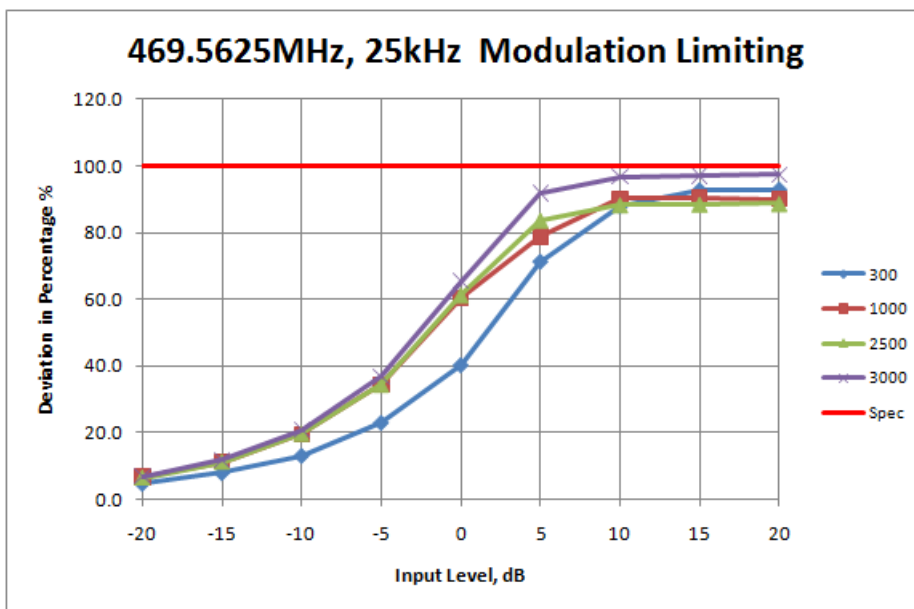
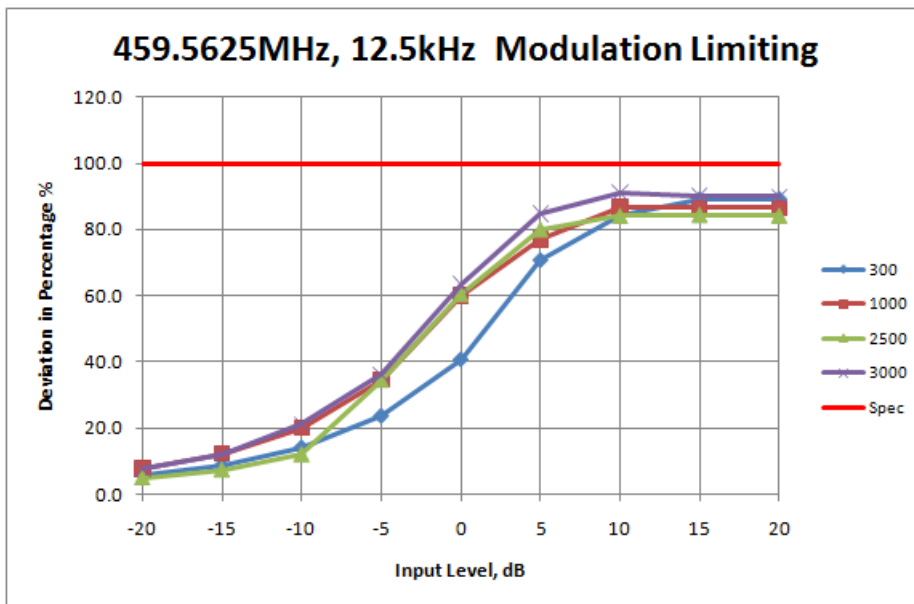

NOT FOR FCC REVIEW

### 6.5.3. Test Limit

Modulation Limiting shall not exceed 100 percent.

## 6.6. Occupied Bandwidth

### 6.6.1. Test Setup (Analog)

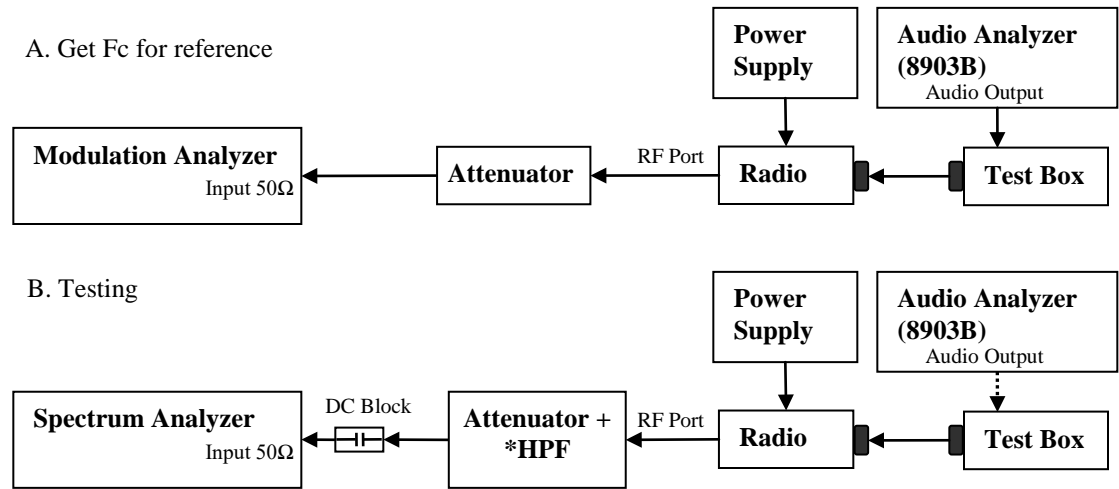

- 1) The DUT transmitter output port was connected to Modulation Analyzer.
- 2) Set the audio bandwidth filter to 15 kHz low pass filter and 50 kHz high pass filter.
- 3) Transmit the radio and set the audio analyzer to 2.5 kHz audio frequency and 50% of the rated deviation. Up the amplitude by 16 dB. Dekey the DUT.
- 4) Path loss for the measurement included.
- 5) Select the Occupied Bandwidth measurement for 99% Emissions Bandwidth Measurement.
- 6) Key in the Fc and Resolution Bandwidth (1 ~ 5 % of emission designator).
- 7) Transmit the DUT and record the occupied Bandwidth frequency.
- 8) Preset the spectrum analyzer for sideband spectrum measurement.
- 9) Set the span and Resolution Bandwidth (according to FCC/ ISED standard).
- 10) Save the screen shot as modulated signal
- 11) Remove the audio tone from audio analyzer to capture unmodulated signal.

\* Only HPF added for Mask 80.211 measurement with attenuator.

### 6.6.2. Test Result (Analog)

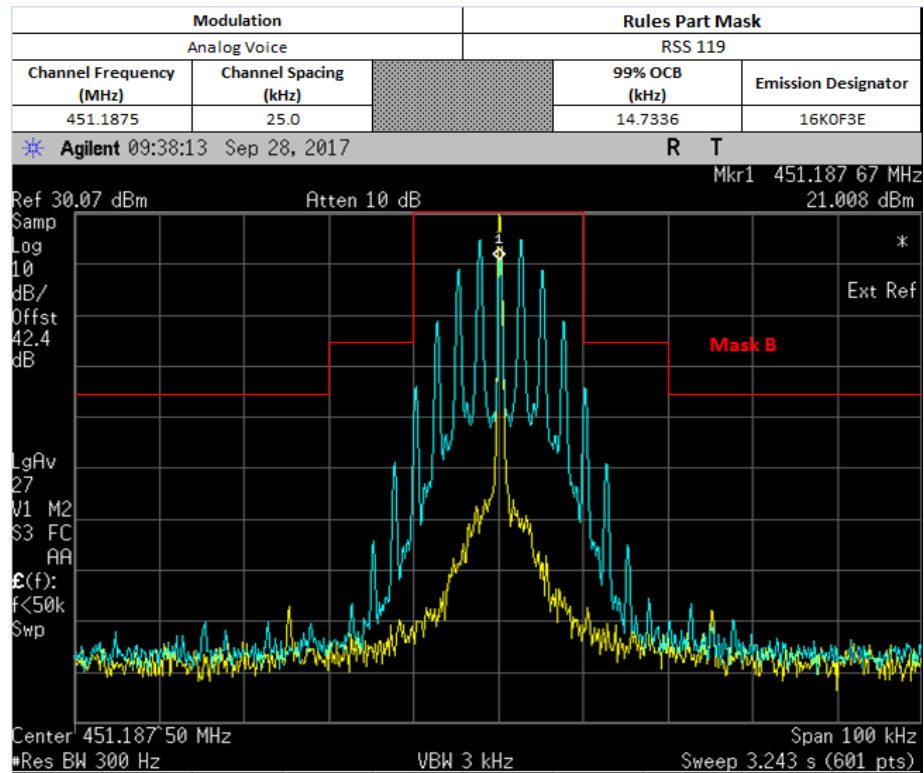
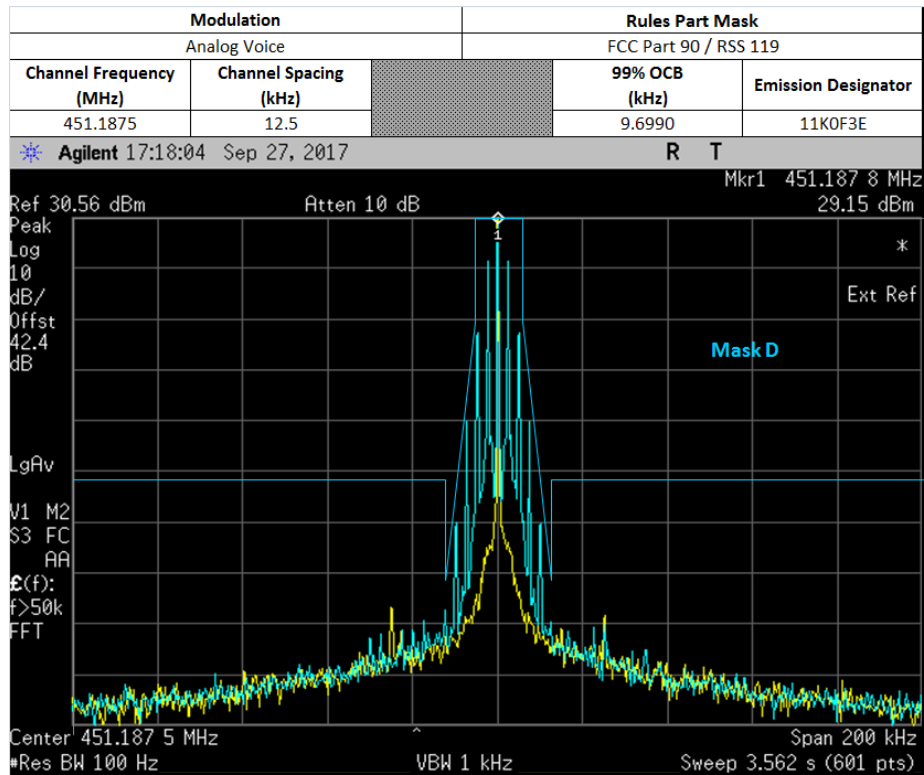

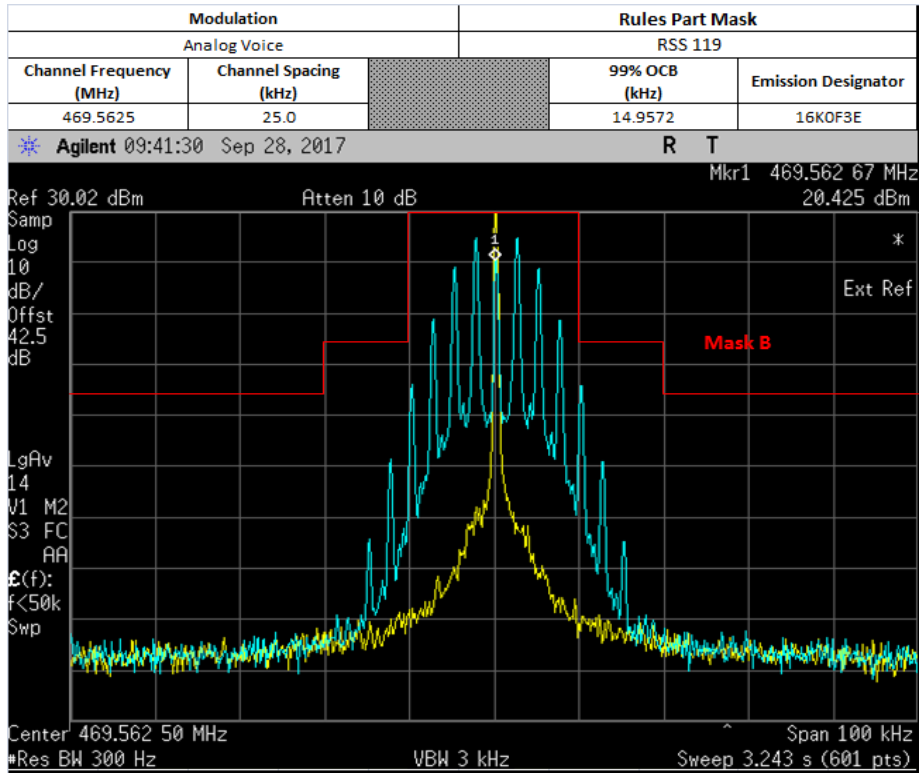

### 6.6.3. Test Setup (Digital)

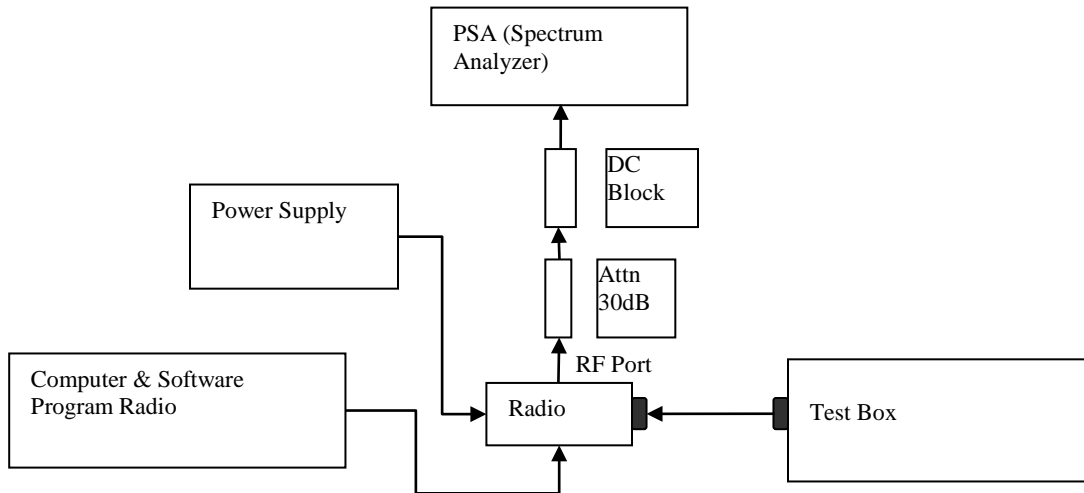

- 1) Program and set radio to operate in desire test frequency and digital mode with modulation. (\*4FSK, C4FM or other digital modulation form).
- 2) Path loss for the measurement included.
- 3) Select the Occupied Bandwidth measurement for 99% Emissions Bandwidth Measurement.
- 4) Key in the Fc and Resolution Bandwidth (1 ~ 5 % of emission designator).
- 5) Transmit the DUT and record the occupied Bandwidth frequency.
- 6) Preset the spectrum analyzer for modulation emission spectrum measurement.
- 7) Set the span and Resolution Bandwidth (according to FCC/ ISED standard).
- 8) Capture the screen shot as modulated signal.

\*Note:

- For Digital Modulation, 12.5 kHz Data F1D & FXD would be the same. Therefore only measurements with F1D modulation shown below.
- For Digital Modulation, 12.5 kHz Data F1E & FXE would be the same. Therefore only measurements with F1E modulation shown below.

### 6.6.4. Test Result (Digital) NA → Not Applicable

### 6.6.5. Test Limit

The 99% occupied bandwidth is the width of a frequency band such that, below the lower and above the upper frequency limits, the mean powers emitted are each equal to a specified percentage 0.5% of the total mean transmitted power.

## 6.7. Band Edge Conducted Spurious Emission (Part 22)

### 6.7.1. Test Setup (Analog)

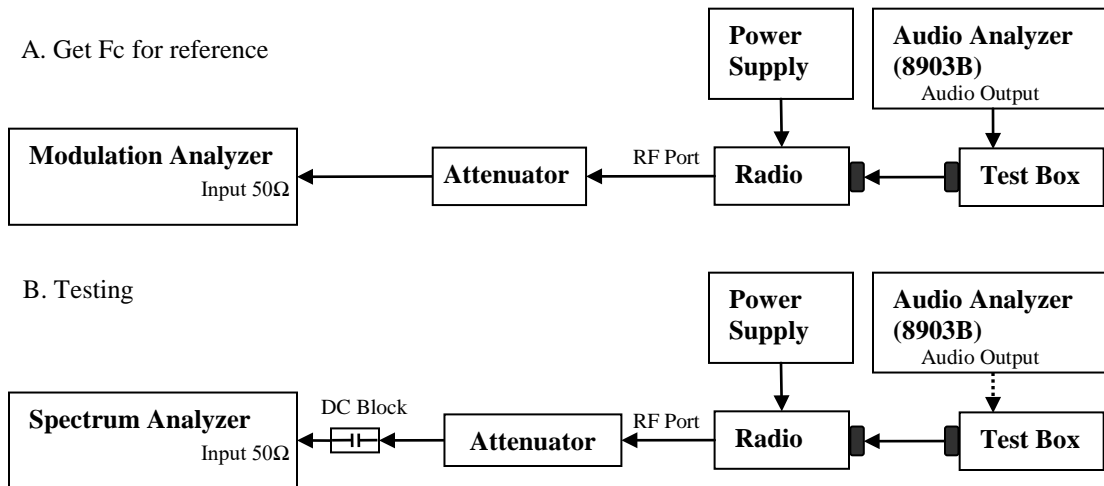

- 2) The DUT transmitter output port was connected to Modulation Analyzer.
- 3) Set the audio bandwidth filter to 15 kHz low pass filter and 50 kHz high pass filter.
- 4) Transmit the radio and set the audio analyzer to 2.5 kHz audio frequency and 50% of the rated deviation. Up the amplitude by 16 dB. Dekey the DUT.
- 5) Path loss for the measurement included.
- 6) Select the Occupied Bandwidth measurement for 99% and 26dB Emissions Bandwidth Measurement.
- 7) Key in the Fc and Resolution Bandwidth.
- 8) Transmit the DUT and record the occupied Bandwidth frequencies.
- 9) Preset the spectrum analyzer for band edge measurement.
- 10) The band edges of lowest and highest channels were measured.
- 11) Key in the Lowest and highest channel frequency, span is 60 kHz and Resolution Bandwidth is at least 1% of Emission Bandwidth.
- 12) Save the screen shot as modulated signal.
- 13) Remove the audio tone from audio analyzer to capture unmodulated signal.

\*Note:

- For emission designator ending with F3E, 16K0F3E is the worst case and therefore only 16K0F3E will be shown.

### 6.7.2. Test Result (Analog) NA → Not Applicable

### 6.7.3. Test Setup (Digital)

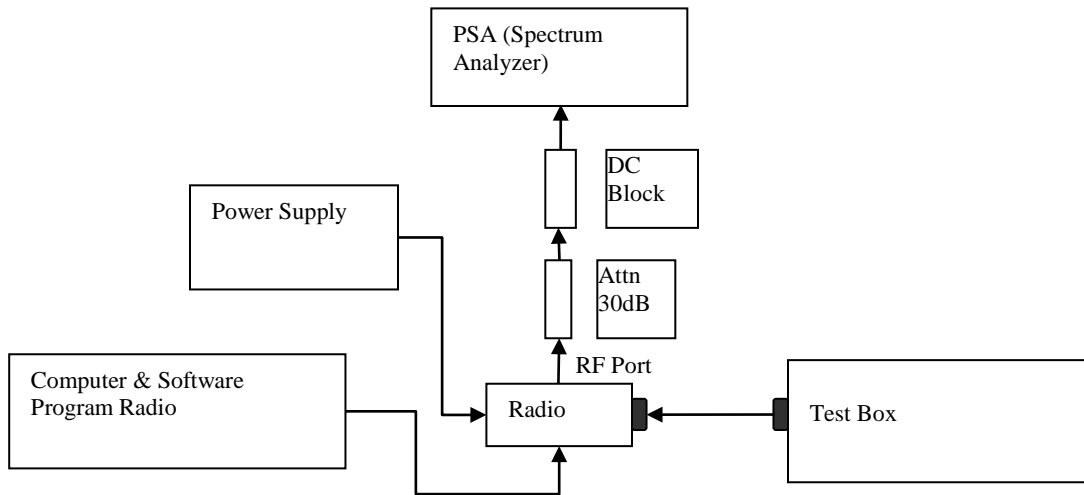

- 1) Program and set radio to operate in desire test frequency and digital mode with modulation. (\*4FSK, C4FM or other digital modulation form).
- 2) Path loss for the measurement included.
- 3) Select the Occupied Bandwidth measurement for 99% and 26dB Emissions Bandwidth Measurement.
- 4) Key in the Fc and Resolution Bandwidth.
- 5) Transmit radio record the occupied Bandwidth frequencies.
- 6) Preset the spectrum analyzer for band edge measurement.
- 7) Key in the lowest and highest channels frequency, span is 60 kHz and Resolution Bandwidth is at least 1% of Emission Bandwidth.
- 8) Save the screen shot.

\*Note:

- For Digital Modulation, 12.5 kHz Data F1D & FXD would be the same. Therefore only measurements with F1D modulation shown below.
- For Digital Modulation, 12.5 kHz Data F1E & FXE would be the same. Therefore only measurements with F1E modulation shown below.

### 6.7.4. Test Result (Digital) NA → Not Applicable

### 6.7.5. Test Limit

The power of any emission outside of the authorized operating frequency ranges must be attenuated below the transmitting power (P) by a factor of at least  $43 + 10 \log(P)$  dB.



## 6.8. Transient Frequency Behavior

### 6.8.1. Test Setup

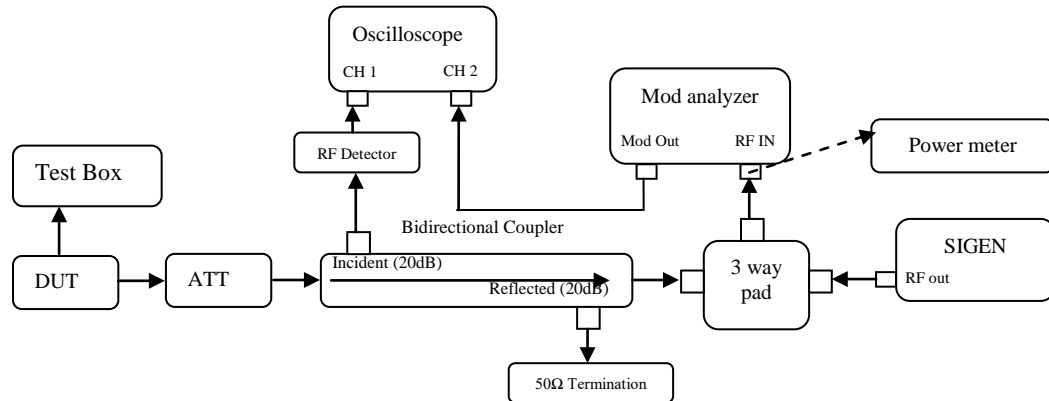

- 1) Connect the setup as figure above.
- 2) Path loss for the measurement included.
- 3) Set on Sigen with the assigned center frequency, internal 1 kHz FM tone.  
FM Deviation: Analog 25kHz Channel Spacing = 25 kHz  
Analog 12.5 kHz Channel Spacing = 12.5 kHz  
C4FM = 12.5 kHz
- 4) Turn on 50 kHz high pass filter and 15 kHz low pass filter on modulation analyzer.
- 5) Supply sufficient attenuation ATT to provide the output power of  $\leq -11\text{dBm}$  into power meter when DUT is keying up.
- 6) Note the power level on power meter and dekey the DUT.
- 7) Adjust the amplitude of the signal generator to the level power meter, maintained the amplitude throughout the rest of the measurement.
- 8) Connect the output to modulation analyzer.
- 9) Reduce 30dB attenuation and transmit the radio to get the trigger line.
- 10) Capture the screen shot for key-up (rising edge) and de-key (falling edge) mode.

**6.8.2. Test Result**  
**Analog : 469.5625MHz ,12.5kHz,FCC Part 90**  
**Key-Up(Rising Edge)**

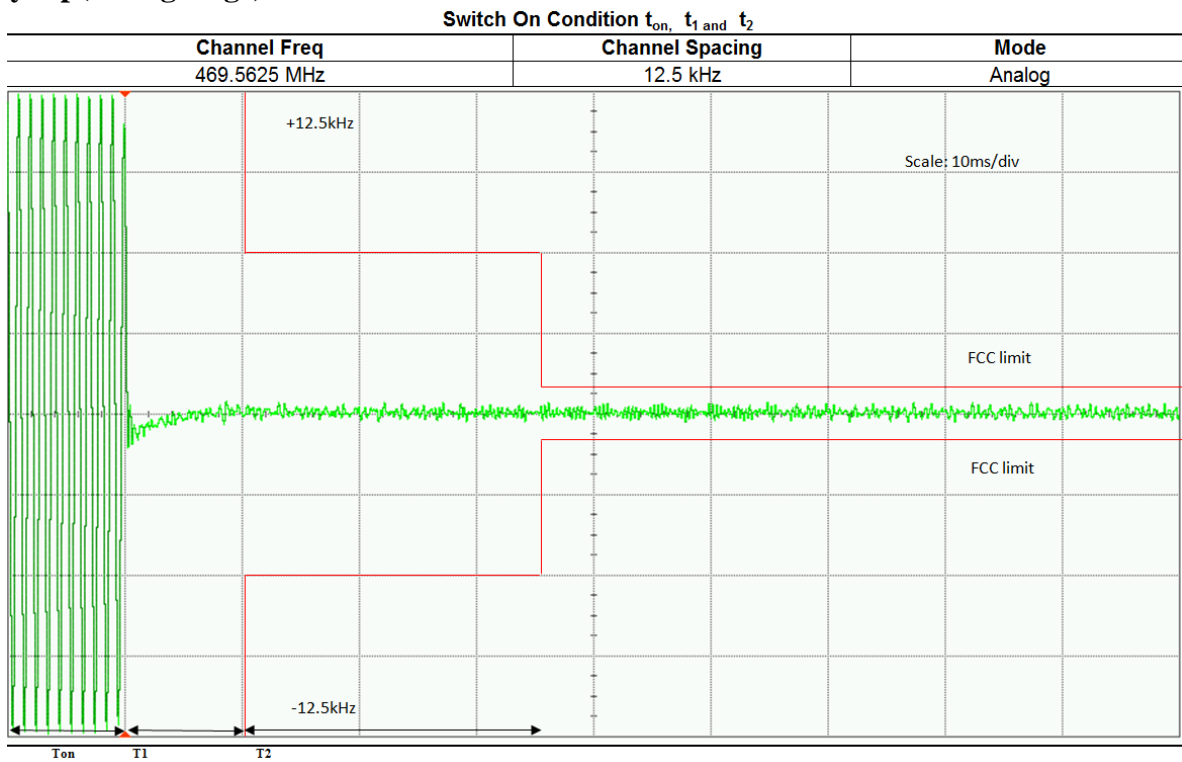

**De-Key(Falling Edge)**

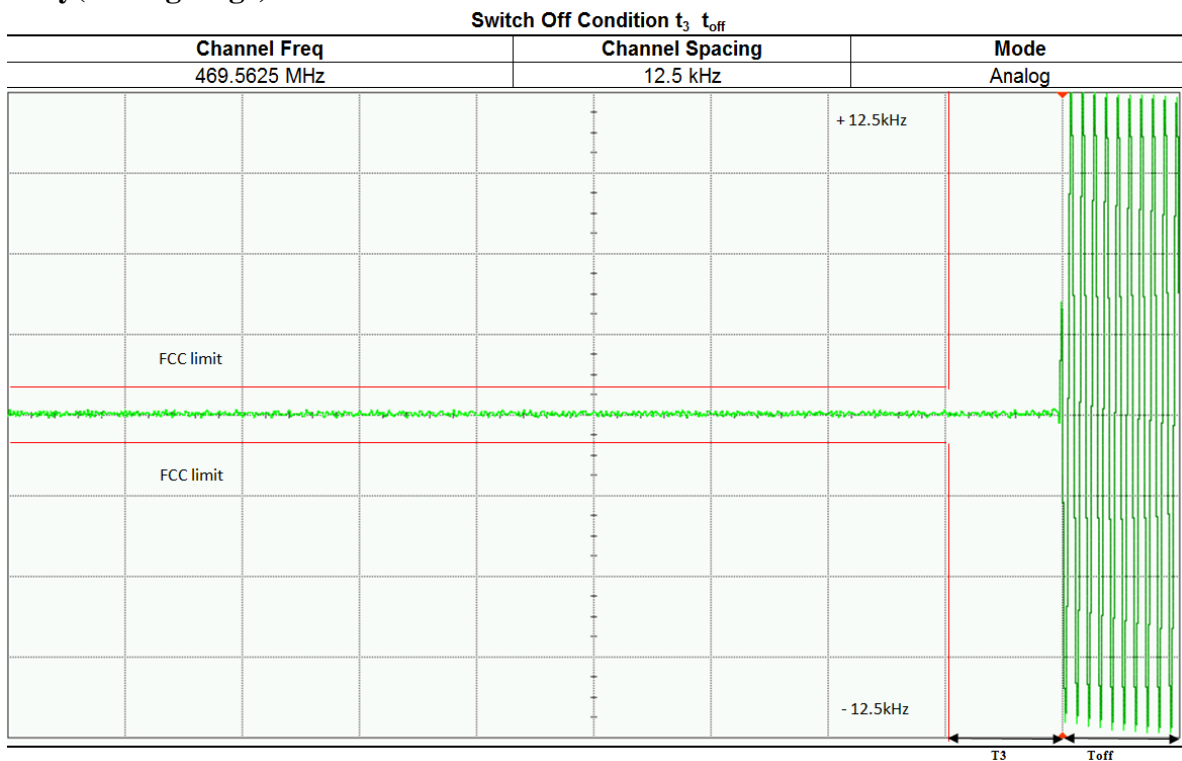

**Analog : 469.5625MHz ,25.0kHz (NOT FOR FCC REVIEW)**

**Key-Up(Rising Edge)**

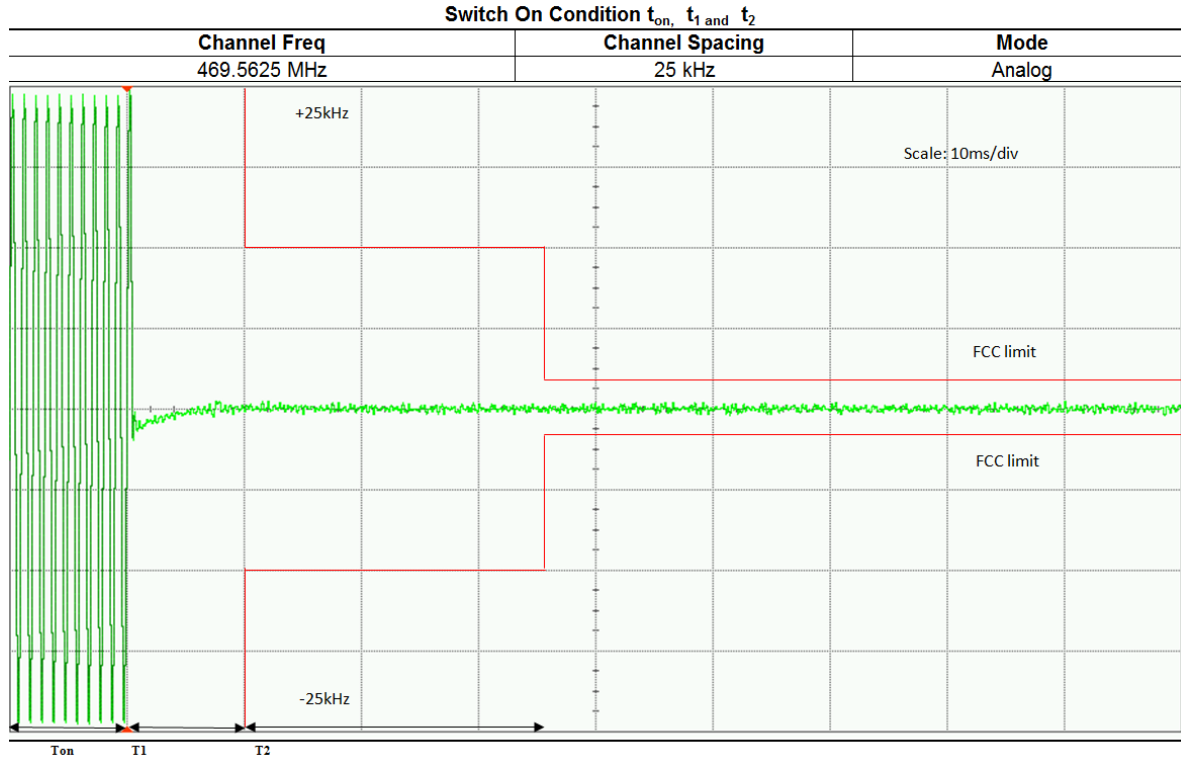

**De-Key(Falling Edge)**

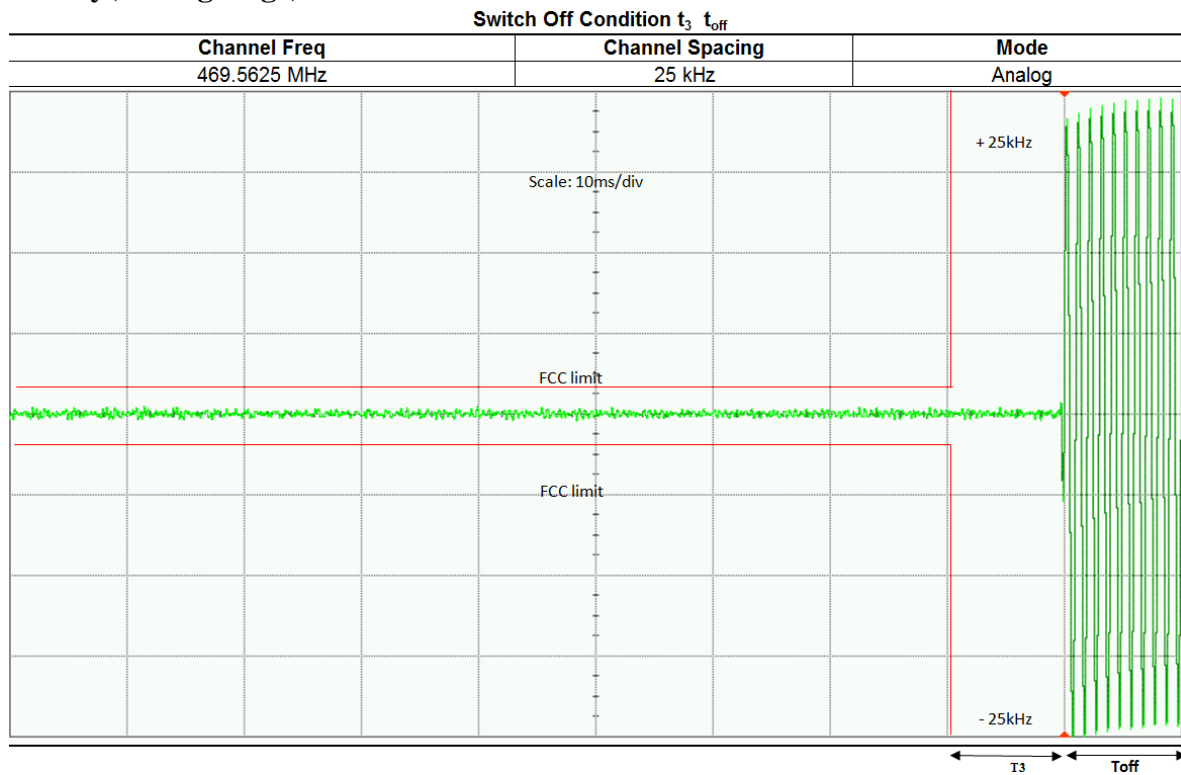

### 6.8.3. Test Limit

Transmitters designed to operate in the 150-174 MHz and 421-512 MHz frequency bands must maintain transient frequencies within the maximum frequency difference limits during the time intervals indicated:

| Time intervals <sup>1 2</sup>   | Maximum frequency difference <sup>3</sup> | All equipment  |                |
|---|---|----------------|----------------|
|   |   | 150 to 174 MHz | 421 to 512 MHz |
| Transient Frequency Behavior for Equipment Designed to Operate on 25 kHz Channels   |   |                |                |
| t <sub>1</sub> <sup>4</sup>   | ±25.0 kHz                                 | 5.0 ms         | 10.0 ms        |
| t <sub>2</sub>  | ±12.5 kHz                                 | 20.0 ms        | 25.0 ms        |
| t <sub>3</sub> <sup>4</sup>   | ±25.0 kHz                                 | 5.0 ms         | 10.0 ms        |
| Transient Frequency Behavior for Equipment Designed to Operate on 12.5 kHz Channels |   |                |                |
| t <sub>1</sub> <sup>4</sup>   | ±12.5 kHz                                 | 5.0 ms         | 10.0 ms        |
| t <sub>2</sub>  | ±6.25 kHz                                 | 20.0 ms        | 25.0 ms        |
| t <sub>3</sub> <sup>4</sup>   | ±12.5 kHz                                 | 5.0 ms         | 10.0 ms        |
| Transient Frequency Behavior for Equipment Designed to Operate on 6.25 kHz Channels |   |                |                |
| t <sub>1</sub> <sup>4</sup>   | ±6.25 kHz                                 | 5.0 ms         | 10.0 ms        |
| t <sub>2</sub>  | ±3.125 kHz                                | 20.0 ms        | 25.0 ms        |
| t <sub>3</sub> <sup>4</sup>   | ±6.25 kHz                                 | 5.0 ms         | 10.0 ms        |

<sup>1</sup> <sub>on</sub> is the instant when a 1 kHz test signal is completely suppressed, including any capture time due to phasing.

t<sub>1</sub> is the time period immediately following t<sub>on</sub>.

t<sub>2</sub> is the time period immediately following t<sub>1</sub>.

t<sub>3</sub> is the time period from the instant when the transmitter is turned off until t<sub>off</sub>.

t<sub>off</sub> is the instant when the 1 kHz test signal starts to rise.

<sup>2</sup> During the time from the end of t<sub>2</sub> to the beginning of t<sub>3</sub>, the frequency difference must not exceed the limits specified in §90.213.

<sup>3</sup> Difference between the actual transmitter frequency and the assigned transmitter frequency.

<sup>4</sup> If the transmitter carrier output power rating is 6 watts or less, the frequency difference during this time period may exceed the maximum frequency difference for this time period.

## 6.9. Adjacent Channel Power

### 6.9.1. Test Setup (Analog)

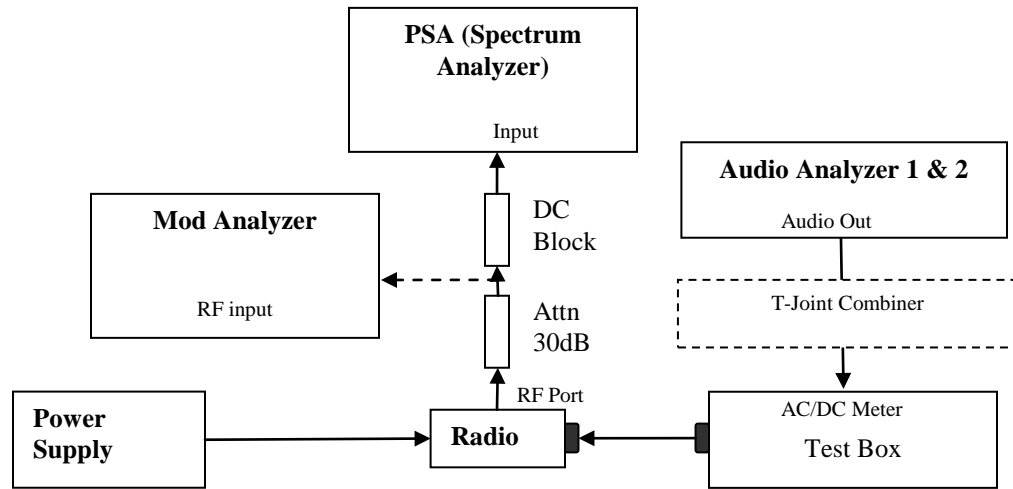

- 1) The DUT transmitter output port was connected to modulation analyzer.
- 2) Transmit the radio and turn on 1<sup>st</sup> audio analyzer with audio frequency 650Hz, 50% rated deviation, and record the amplitude value as AmpT1.
- 3) Turn off Audio analyzer 1 and turn on audio analyzer 2, set the audio frequency to 2.2 kHz and 50% deviation. Record the amplitude as AmpT2.
- 4) Turn both audio analyzers ON and up 10dB amplitude level.
- 5) Connect the output to PSA and set to assigned center frequency.
- 6) Set Span, Resolution Bandwidth and Video Bandwidth per rules part.
- 7) Transmit the radio and record the Adjacent Channel Power value in dBc.

### 6.9.2. Test Result

NA → Not Applicable

### 6.9.3. Test Setup (Digital)

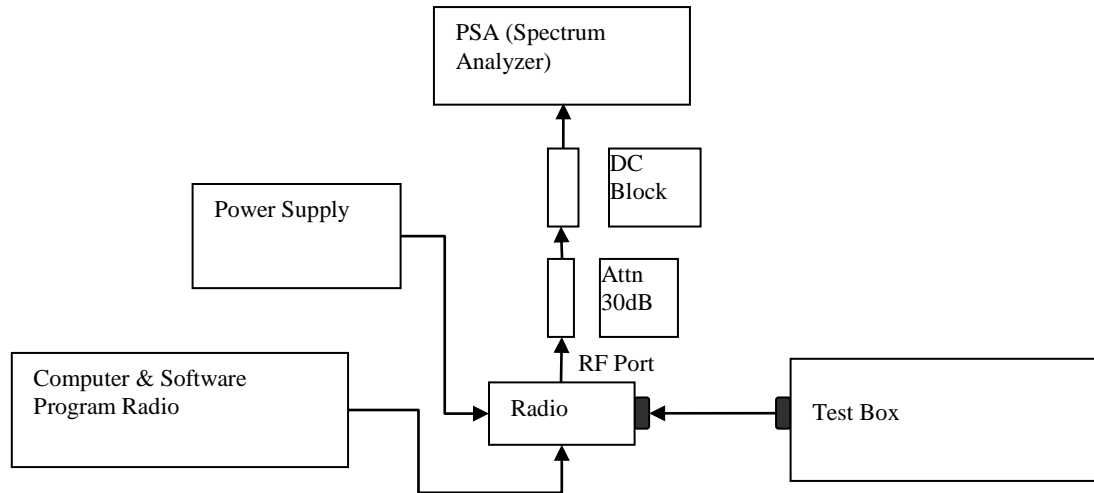

- 1) Program and set radio to operate in desire test frequency and digital mode with modulation. (4FSK, C4FM or other digital modulation form).
- 2) Prepare setup as per picture.
- 3) Turn on the ACP Measurement – Press Measure, ACP.
- 4) Set Span, Resolution Bandwidth and Video Bandwidth as per rules part.
- 5) Transmit the radio and record the Adjacent Channel Power value in dBc.

### 6.9.4. Test Result

**NA → Not Applicable**

### 6.9.5. Test Limit

#### 12.5 kHz MOBILE TRANSMITTER ACP REQUIREMENTS

| Offset from center frequency (kHz) | Measurement bandwidth (kHz) | Maximum ACP relative (dBc) |
|------------------------------------|-----------------------------|----------------------------|
| 9.375                              | 6.25                        | -40                        |
| 15.625                             | 6.25                        | -60                        |
| 21.875                             | 6.25                        | -60                        |
| 37.50                              | 25.00                       | -60                        |
| 62.50                              | 25.00                       | -65                        |
| 87.50                              | 25.00                       | -65                        |
| 150.00                             | 100                         | -65                        |
| 250.00                             | 100                         | -65                        |
| 350.00                             | 100                         | -65                        |
| >400 to 12 MHz                     | 30 (s)                      | -75                        |
| 12 MHz to paired receive band      | 30 (s)                      | -75                        |
| In the paired receive band         | 30 (s)                      | -100                       |

#### 25 kHz MOBILE TRANSMITTER ACP REQUIREMENTS

| Offset from center frequency (kHz) | Measurement bandwidth (kHz) | Maximum ACP relative (dBc) |
|------------------------------------|-----------------------------|----------------------------|
| 15.625                             | 6.25                        | -40                        |
| 21.875                             | 6.25                        | -60                        |
| 37.50                              | 25                          | -60                        |
| 62.50                              | 25                          | -65                        |
| 87.50                              | 25                          | -65                        |
| 150.00                             | 100                         | -65                        |
| 250.00                             | 100                         | -65                        |
| 350.00                             | 100                         | -65                        |
| >400 kHz to 12 MHz                 | 30 (s)                      | -75                        |
| 12 MHz to paired receive band      | 30 (s)                      | -75                        |
| In the paired receive band         | 30 (s)                      | -100                       |

**12.5 kHz BASE TRANSMITTER ACP REQUIREMENTS**

| Offset from center frequency (kHz) | Measurement bandwidth (kHz) | Maximum ACP (dBc) |
|------------------------------------|-----------------------------|-------------------|
| 9.375                              | 6.25                        | -40               |
| 15.625                             | 6.25                        | -60               |
| 21.875                             | 6.25                        | -60               |
| 37.5                               | 25                          | -60               |
| 62.5                               | 25                          | -65               |
| 87.5                               | 25                          | -65               |
| 150                                | 100                         | -65               |
| 250                                | 100                         | -65               |
| 350.00                             | 100                         | -65               |
| >400 kHz to 12 MHz                 | 30 (s)                      | -80               |
| 12 MHz to paired receive band      | 30 (s)                      | -80               |
| In the paired receive band         | 30 (s)                      | -1.85             |

**25 kHz BASE TRANSMITTER ACP REQUIREMENTS**

| Offset from center frequency (kHz) | Measurement bandwidth (kHz) | Maximum ACP (dBc) |
|------------------------------------|-----------------------------|-------------------|
| 15.625                             | 6.25                        | -40               |
| 21.875                             | 6.25                        | -60               |
| 37.5                               | 25                          | -60               |
| 62.5                               | 25                          | -65               |
| 87.5                               | 25                          | -65               |
| 150                                | 100                         | -65               |
| 250                                | 100                         | -65               |
| 350                                | 100.00                      | -65               |
| >400 kHz to 12 MHz                 | 30 (s)                      | -80               |
| 12 MHz to paired receive band      | 30 (s)                      | -80               |
| In the paired receive band         | 30 (s)                      | -1.85             |



## 6.10. Conducted Spurious Emission

### 6.10.1. Test Setup

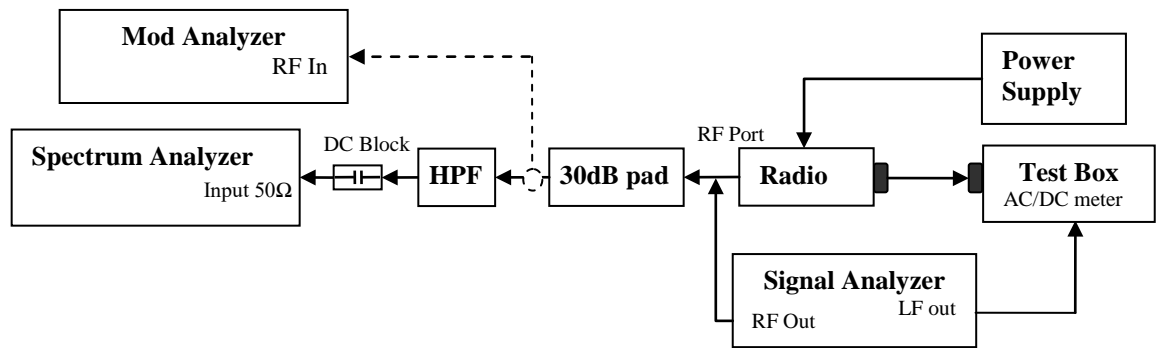

- 1) The DUT transmitter output port was connected to Modulation Analyzer or Spectrum Analyzer with above setup.
- 2) For analog measurement, turn off the High Pass Filter path and turn on 15 kHz low pass filter on modulation analyzer. Set Sigen to LF out ON with the assigned center frequency. Key up the DUT to get the 50% of rated deviation at mod analyzer and up amplitude 16dB with internal 2.5 kHz FM tone.
- 3) For Digital Measurement, Program and set radio to operate in desire test frequency and digital mode with modulation. (4FSK, C4FM or other digital modulation form).
- 4) Path loss for the measurement included.
- 5) Set the spectrum Resolution Bandwidth as per rules part.
- 6) Adjust the center frequency of the spectrum analyzer for incremental coverage of the range from:
  - a. 9 KHz to  $F_c - \text{Test Bandwidth}$
  - b.  $F_c + \text{Test Bandwidth}$  to  $2F_c - 5\text{MHz}$ .
- 7) Key up the DUT, record all the frequencies and levels of spurious emissions from step 5) and dekey the DUT.
- 8) Turn On HPF path and Key up the DUT.
- 9) Adjust the PSA Freq for coverage of range from  $2F_c$  to  $10F_c$ , record the spur and harmonics level in dBm.
- 10) Whichever Spur level in step 7) & step 9) is within 20dB from the test limit, replace the DUT with the Sigen and adjust the signal level to reproduce the frequencies & levels. Record the signal generator levels in dBm.

### 6.10.2. Test Result (Analog)

#### Analog: 451.1875 MHz, 12.5 kHz Channel Spacing, Max Power FCC Part 90 and RSS 119

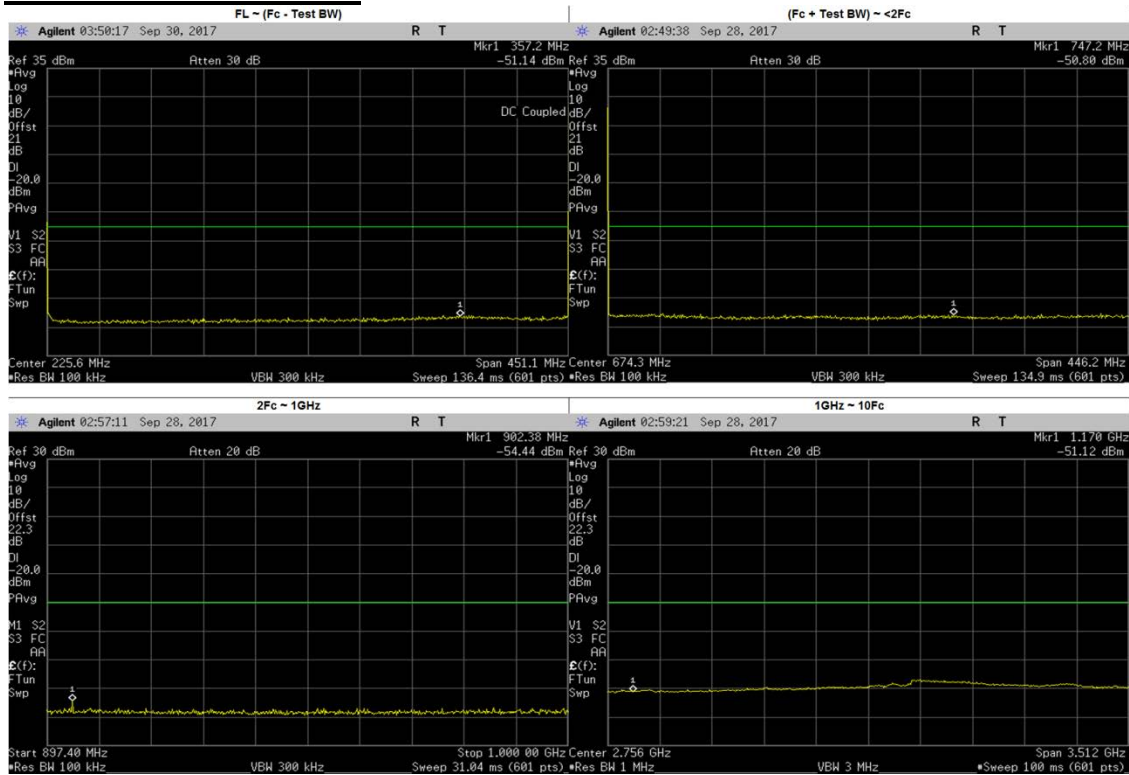

| Frequency Range       | Highest Spur Frequency (MHz) | Spurious Level (MHz) | Failing Limit (dBm) |
|-----------------------|------------------------------|----------------------|---------------------|
| FL ~ (Fc - Test BW)   | 357.2000                     | -51.14               | -20                 |
| (Fc + Test BW) ~ <2Fc | 747.2000                     | -50.80               | -20                 |
| 2Fc ~ 1GHz            | 902.3800                     | -54.44               | -20                 |
| 1GHz ~ 10Fc           | 1353.5625                    | -51.00               | -20                 |
|                       | 1804.7500                    | -50.57               | -20                 |
|                       | 2255.9375                    | -50.36               | -20                 |
|                       | 2707.1250                    | -49.57               | -20                 |
|                       | 3158.3125                    | -47.38               | -20                 |
|                       | 3609.5000                    | -48.75               | -20                 |
|                       | 4060.6875                    | -48.57               | -20                 |
|                       | 4511.8888                    | -49.65               | -20                 |

**Analog: 451.1875 MHz, 25.0 kHz Channel Spacing, Max Power  
 RSS 119**

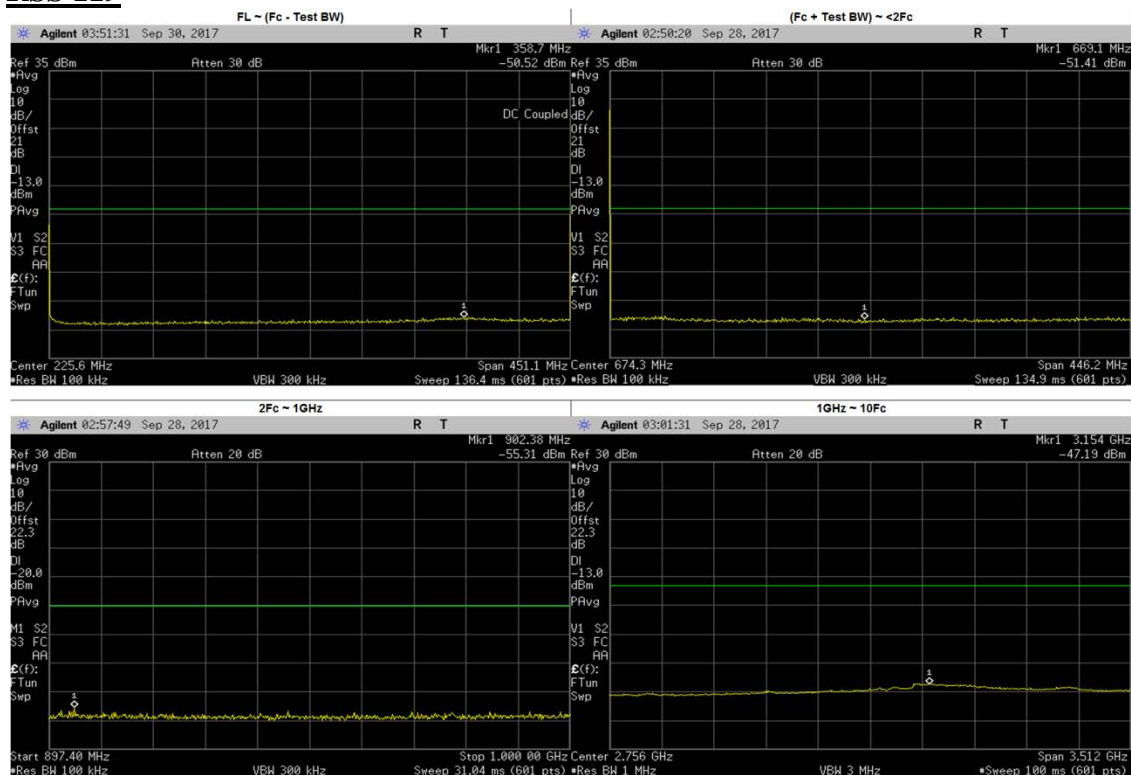

| Frequency Range       | Highest Spur Frequency (MHz) | Spurious Level (MHz) | Failing Limit (dBm) |
|-----------------------|------------------------------|----------------------|---------------------|
| FL ~ (Fc - Test BW)   | 358.7000                     | -50.52               | -13                 |
| (Fc + Test BW) ~ <2Fc | 669.1000                     | -51.41               | -13                 |
| 2Fc ~ 1GHz            | 902.3800                     | -55.31               | -13                 |
| 1GHz ~ 10Fc           | 1353.5625                    | -51.08               | -13                 |
|                       | 1804.7500                    | -50.66               | -13                 |
|                       | 2255.9375                    | -50.32               | -13                 |
|                       | 2707.1250                    | -49.68               | -13                 |
|                       | 3158.3125                    | -47.28               | -13                 |
|                       | 3609.5000                    | -48.53               | -13                 |
|                       | 4060.6875                    | -48.52               | -13                 |
|                       | 4511.8888                    | -49.21               | -13                 |

**Analog: 461.0375 MHz, 12.5 kHz Channel Spacing, Max Power  
 FCC Part 90**

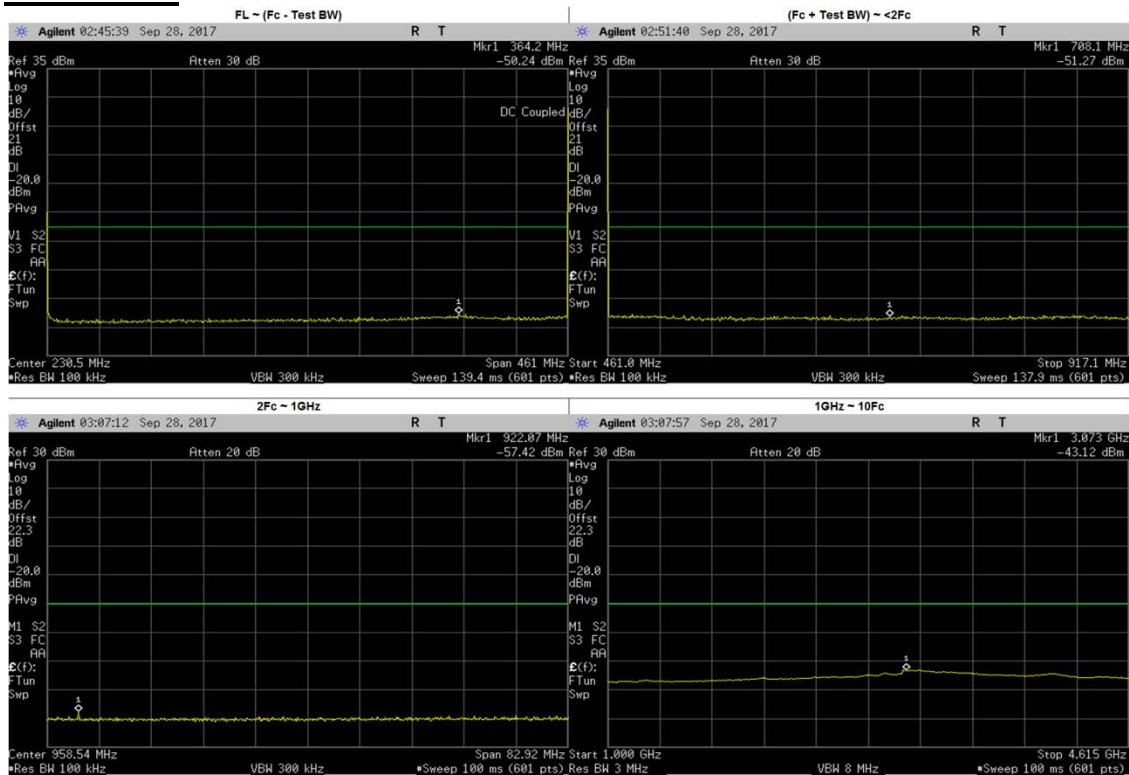

| Frequency Range       | Highest Spur Frequency (MHz) | Spurious Level (MHz) | Failing Limit (dBm) |
|-----------------------|------------------------------|----------------------|---------------------|
| FL ~ (Fc - Test BW)   | 364.2000                     | -50.24               | -20                 |
| (Fc + Test BW) ~ <2Fc | 708.1000                     | -51.27               | -20                 |
| 2Fc ~ 1GHz            | 922.0700                     | -57.42               | -20                 |
| 1GHz ~ 10Fc           | 1383.1125                    | -46.69               | -20                 |
|                       | 1844.1500                    | -46.59               | -20                 |
|                       | 2305.1875                    | -46.02               | -20                 |
|                       | 2766.2250                    | -45.06               | -20                 |
|                       | 3227.2625                    | -43.48               | -20                 |
|                       | 3688.3000                    | -44.92               | -20                 |
|                       | 4149.3375                    | -44.84               | -20                 |
|                       | 4610.3750                    | -46.11               | -20                 |

**Analog: 469.5625 MHz, 12.5 kHz Channel Spacing, Max Power  
 FCC Part 90 and RSS 119**

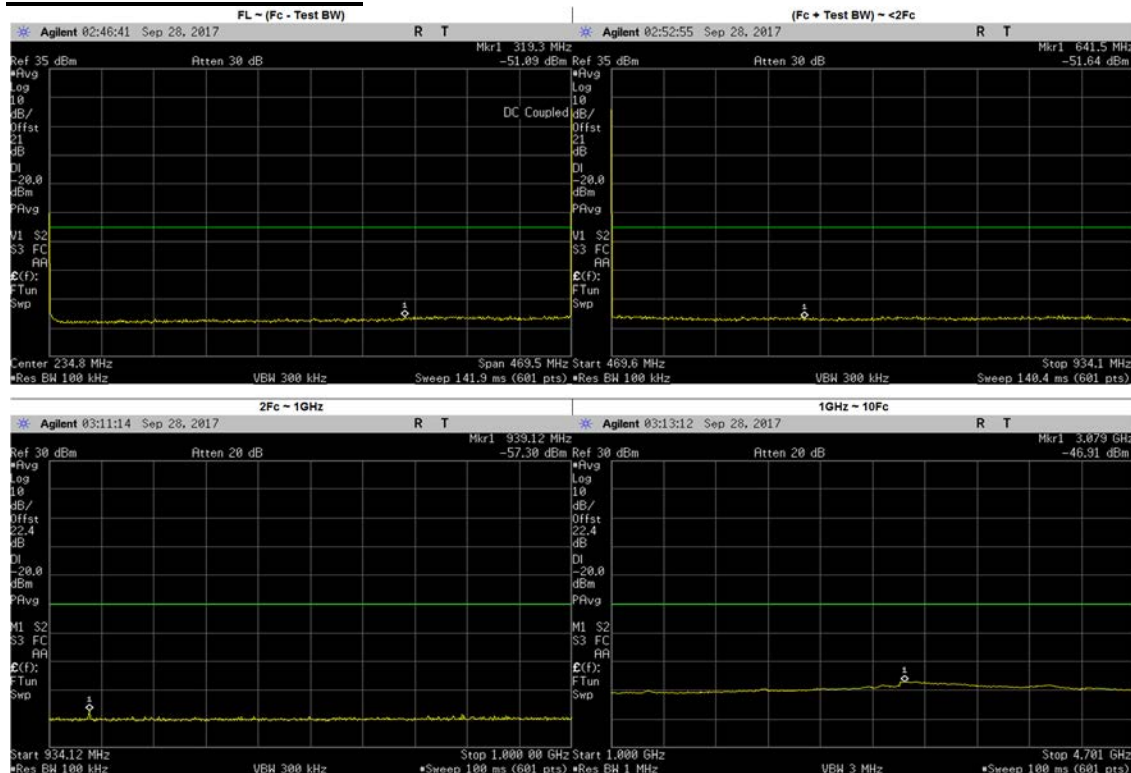

| Frequency Range       | Highest Spur Frequency (MHz) | Spurious Level (MHz) | Failing Limit (dBm) |
|-----------------------|------------------------------|----------------------|---------------------|
| FL ~ (Fc - Test BW)   | 319.3000                     | -51.09               | -20                 |
| (Fc + Test BW) ~ <2Fc | 641.5000                     | -51.64               | -20                 |
| 2Fc ~ 1GHz            | 939.1200                     | -57.30               | -20                 |
| 1GHz ~ 10Fc           | 1408.6875                    | -50.86               | -20                 |
|                       | 1878.2500                    | -50.50               | -20                 |
|                       | 2347.8125                    | -50.06               | -20                 |
|                       | 2817.3750                    | -48.61               | -20                 |
|                       | 3286.9375                    | -47.43               | -20                 |
|                       | 3756.5000                    | -48.70               | -20                 |
|                       | 4226.0625                    | -48.99               | -20                 |
|                       | 4695.6250                    | -49.91               | -20                 |

**Analog: 469.5625 MHz, 25.0 kHz Channel Spacing, Max Power  
 RSS 119**

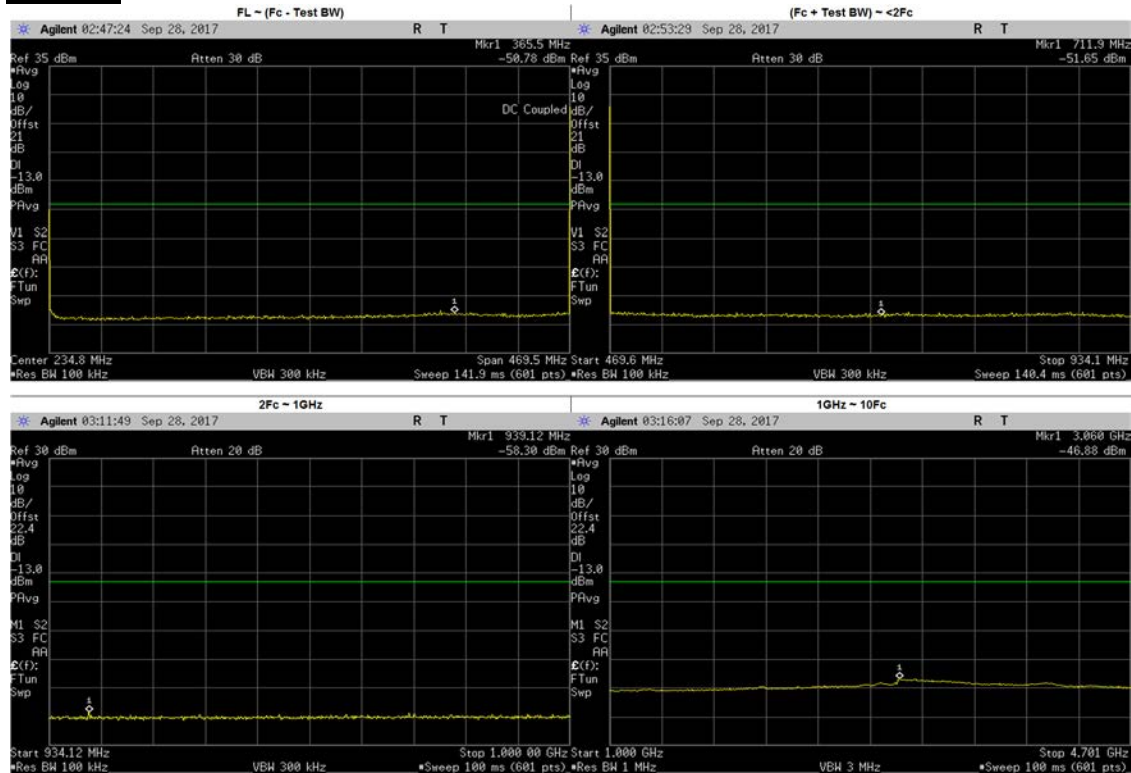

| Frequency Range       | Highest Spur Frequency (MHz) | Spurious Level (MHz) | Failing Limit (dBm) |
|-----------------------|------------------------------|----------------------|---------------------|
| FL ~ (Fc - Test BW)   | 365.5000                     | -50.78               | -13                 |
| (Fc + Test BW) ~ <2Fc | 711.9000                     | -51.65               | -13                 |
| 2Fc ~ 1GHz            | 939.1250                     | -58.30               | -13                 |
| 1GHz ~ 10Fc           | 1408.6875                    | -50.67               | -13                 |
|                       | 1878.2500                    | -50.40               | -13                 |
|                       | 2347.8125                    | -49.76               | -13                 |
|                       | 2817.3750                    | -48.72               | -13                 |
|                       | 3286.9375                    | -47.39               | -13                 |
|                       | 3756.5000                    | -48.53               | -13                 |
|                       | 4226.0625                    | -49.13               | -13                 |
|                       | 4695.6250                    | -49.73               | -13                 |

**6.10.3. Test Result (Digital)**  
**NA → Not Applicable**

**6.10.4. Test Limit**

The power of any emission outside a licensee’s frequency block shall be attenuated below the transmitter power (P) by at least:

| Channel Spacing | Part 22                    | Part 24D                   | Part 74                    | Part 80                    | Part 90 (UHF, VHF, 800, 900) | Part 90 (700)              |
|-----------------|----------------------------|----------------------------|----------------------------|----------------------------|------------------------------|----------------------------|
| 12.5kHz         | 43 + log10(P)<br>(-13 dBm) | 43 + log10(P)<br>(-13 dBm) | 43 + log10(P)<br>(-13 dBm) | Not Applicable             | 50 + log10(P)<br>(-20 dBm)   | 43 + log10(P)<br>(-13 dBm) |
| 25kHz           |                            | Not Applicable             |                            | 43 + log10(P)<br>(-13 dBm) | 43 + log10(P)<br>(-13 dBm)   | 43 + log10(P)<br>(-13 dBm) |

## 6.11. Radiated Spurious Emission

### 6.11.1. Test Setup

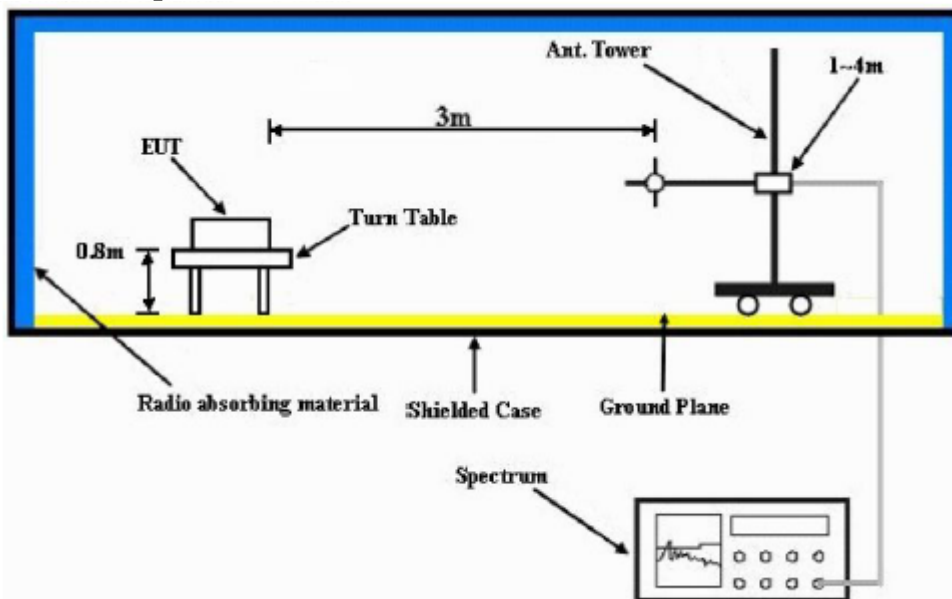

- 1) The Resolution Bandwidth for scanning Radiated Emission below 1 GHz is 100 kHz with Video Bandwidth = 300 kHz and Resolution Bandwidth for above 1 GHz is 1 MHz with Video Bandwidth = 3 MHz. Detector mode is positive peak.
- 2) In the semi- anechoic chamber, setup as illustrated above the DUT placed on the 0.8m height of Turn Table, rotated the table around 360 degrees to search the maximum radiation power and receiver antenna shall be rotated vertical and horizontal polarization and moved height from 1m to 4m to find the maximum polar radiated power. The “Read Value” is the spectrum reading the maximum power value.
- 3) The substitution antenna is substituted for DUT at the same position and signals generator (S.G) export the CW signal to the substitution antenna via a TX cable. The receiver antenna shall be rotated vertical and horizontal polarization and moved height from 1m to 4m to find the maximum radiation power. Record the power level of maximum radiation power from spectrum. So, the measured substitution value = Ref level of S.G + TX cables loss – Substituted Antenna Gain.
- 4) Final Radiated Spurious Emission = “Read Value” + Measured substitution value.



**6.11.2. Test Result (Analog)**  
 NA → Not Applicable

**6.11.3. Test Result (Digital)**  
 NA → Not Applicable

**6.11.4. Test Limit**

Table below summarized the power of any emission outside a licensee’s frequency block shall be attenuated below the transmitter power (P) by at least

| Channel Spacing | Part 22                                 | Part 24D                                | Part 74                                 | Part 80                                 | Part 90 (UHF, VHF, 800, 900)            | Part 90 (700)                           |
|-----------------|---|---|---|---|---|---|
| 12.5kHz         | 43 + log <sub>10</sub> (P)<br>(-13 dBm) | 43 + log <sub>10</sub> (P)<br>(-13 dBm) | 43 + log <sub>10</sub> (P)<br>(-13 dBm) | Not Applicable                          | 50 + log <sub>10</sub> (P)<br>(-20 dBm) | 43 + log <sub>10</sub> (P)<br>(-13 dBm) |
| 25kHz           |   | Not Applicable                          |   | 43 + log <sub>10</sub> (P)<br>(-13 dBm) | 43 + log <sub>10</sub> (P)<br>(-13 dBm) | 43 + log <sub>10</sub> (P)<br>(-13 dBm) |

| Channel Spacing | RSS 134                                 | RSS 182                                 | RSS 119 (UHF, VHF, 800, 900)            | RSS 119 (700)                           |
|-----------------|---|---|---|---|
| 12.5kHz         | 43 + log <sub>10</sub> (P)<br>(-13 dBm) | Not Applicable                          | 50 + log <sub>10</sub> (P)<br>(-20 dBm) | 43 + log <sub>10</sub> (P)<br>(-13 dBm) |
| 25kHz           | Not Applicable                          | 43 + log <sub>10</sub> (P)<br>(-13 dBm) | 43 + log <sub>10</sub> (P)<br>(-13 dBm) | 43 + log <sub>10</sub> (P)<br>(-13 dBm) |

## 6.12. Effective Radiated Power (ERP)

### 6.12.1. Test Setup

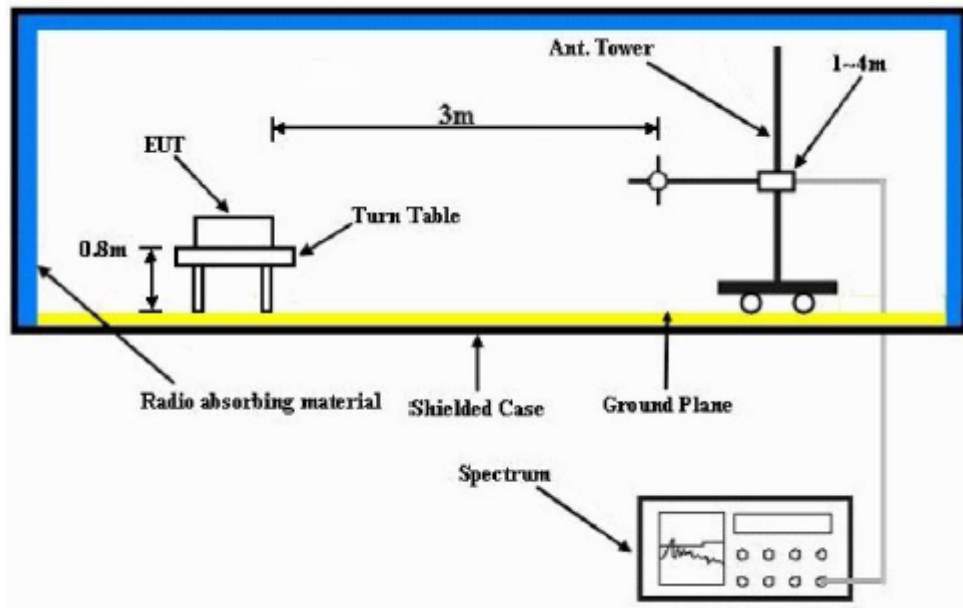

- 1) The Resolution Bandwidth for Equivalent Radiated Power (ERP) below 1 GHz is 100 kHz with Video Bandwidth = 300 kHz and Resolution Bandwidth for EIRP above 1 GHz is 1 MHz with Video Bandwidth = 3 MHz. Detector Mode is RMS.
- 2) In the semi-anechoic chamber, setup as illustrated above the DUT placed on the 0.8m height of Turn Table, rotated the table 45 degree each interval to search the maximum radiation power and receiver antenna shall be rotated vertical and horizontal polarization and moved height from 1m to 4m to find the maximum polar radiated power for each degree interval. The “Read Value” is the spectrum reading of maximum power value.
- 3) The substitution antenna is substituted for DUT at the same position and signals generator (S.G) export the CW signal to the substitution antenna via a TX cable. The receiver antenna shall be rotated vertical and horizontal polarization and moved height from 1m to 4m to find the maximum radiation power. Record the power level of maximum radiation power from spectrum. So, the Measured substitution value = Ref level of S.G + TX cables loss – Substituted Antenna Gain.

**6.12.2. Test Result**  
**NA → Not Applicable**

**6.12.3. Test Limit**  
The maximum output power of the transmitter for mobile stations is 100 watts (20 dB). Power is given in terms of effective radiated power (ERP).

**6.13. GNSS (EIRP for 1559 - 1610MHz)**

**6.13.1. Test Setup**

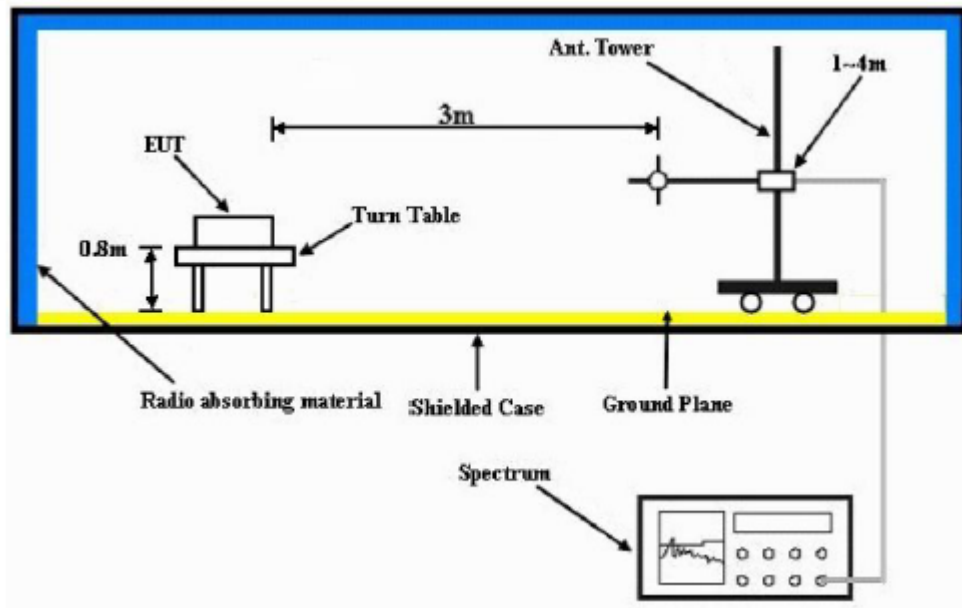

- 4) The Resolution Bandwidth for Equivalent Isotropically Radiated Power (EIRP) below 1 GHz is 100 kHz with Video Bandwidth = 300 kHz and Resolution Bandwidth for EIRP above 1 GHz is 1 MHz with Video Bandwidth = 3 MHz. Detector Mode is RMS.
- 5) In the semi-anechoic chamber, setup as illustrated above the DUT placed on the 0.8m height of Turn Table, rotated the table 45 degree each interval to search the maximum radiation power and receiver antenna shall be rotated vertical and horizontal polarization and moved height from 1m to 4m to find the maximum polar radiated power for each degree interval. The “Read Value” is the spectrum reading of maximum power value.
- 6) The substitution antenna is substituted for DUT at the same position and signals generator (S.G) export the CW signal to the substitution antenna via a TX cable. The receiver antenna shall be rotated vertical and horizontal polarization and moved height from 1m to 4m to find the maximum radiation power. Record the power level of maximum radiation power from spectrum. So, the Measured substitution value = Ref level of S.G + TX cables loss – Substituted Antenna Gain.
- 7)  $EIRP = \text{“Read Value”} + \text{Measured substitution value} + 2.15$ .

**6.13.1. Test Result**  
**NA → Not Applicable**

**6.13.2. Test Limit**  
For operations in the 758-775 MHz and 788-805 MHz bands, all emissions including harmonics in the band 1559-1610 MHz shall be limited to  $-70$  dBW/MHz equivalent isotropically radiated power (EIRP) for wideband signals, and  $-80$  dBW EIRP for discrete emissions of less than 700 Hz bandwidth.

**~ End of Report ~**