

	 TESTING CERT # 2786.01
---	---

MOTOROLA PENANG ADV. COMM. LABORATORY Motorola Solutions Malaysia Sdn Bhd Innoplex Plot 2A, Medan Bayan Lepas, Mukim 12 S.W.D, 11900 Bayan Lepas, Penang, Malaysia.	FCC / IC TEST REPORT Report Revision : Rev.C
--	---

<p>Date/s Tested : 05-JUN-2017 - 14-JUN-2017 Report Issue Date : 24-AUG-2017 Manufacturer/Location : Motorola Solutions Malaysia Sdn Bhd Requestor : TEOH YEE TENG Product Type : Portable Model Number : H92SDF9PW6AN Frequency Band : 450-520 MHz Low / Max RF Output Power : 1 Watt / 5.6 Watts Applicant Name : Motorola Solutions Malaysia Sdn Bhd Applicant Address : Innoplex Plot 2A, Medan Bayan Lepas, Mukim 12 S.W.D, 11900 Bayan Lepas, Penang, Malaysia FCC Registrations : 772092 IC Registrations : 109AK</p> <p>The equipment was tested accordance to the requirement listed below:</p> <p>(LMR) FCC 47 CFR Part 2 / 22 / 74 / 80 / 90 IC RSS-119</p>	 PASS
---	---

This report shall not be reproduced without written approval from an officially designated representative of the Motorola Penang Adv. Comm. Laboratory. The results and statements contained in this report pertain only to the device(s) evaluated.

Prepared By: _____ SONG ZHI WEI Test Personnel	Approved By: _____ GOH AIK HONG Responsible Engineer
---	---

Table of Contents

Report Revision History	3
1.0 General Information.....	4
2.0 Summary of Test Results.....	5
3.0 Measurement Uncertainty.....	5
4.0 Equipment List.....	6
5.0 Test Condition.....	7
5.1. Transmitter Test Conditions	7
6.0 Transmitter Test Parameters	8
6.1. RF Output Power	8
6.1.1. Test Setup.....	8
6.1.2. Test Result	8
6.2. Frequency Stability	9
6.2.1. Test Setup.....	9
6.2.2. Test Result	10
6.2.3. Test Limit.....	11
6.3. Audio Frequency Response	12
6.3.1. Test Setup.....	12
6.3.2. Test Result	13
6.3.3. Test Limit.....	14
6.4. Audio Low Pass Filter Response	15
6.4.1. Test Setup.....	15
6.4.2. Test Result	16
6.4.3. Test Limit.....	17
6.5. Modulation Limiting.....	18
6.5.1. Test Setup.....	18
6.5.2. Test Result	19
6.5.3. Test Limit.....	19
6.6. Occupied Bandwidth.....	20
6.6.1. Test Setup (Analog)	20
6.6.2. Test Result (Analog).....	21
6.6.3. Test Setup (Digital).....	27
6.6.4. Test Result (Digital).....	28
6.6.5. Test Limit.....	34
6.7. Band Edge Conducted Spurious Emission (Part 22)	35
6.7.1. Test Setup (Analog)	35
6.7.2. Test Result (Analog).....	36
6.7.3. Test Result (Digital).....	38
6.7.4. Test Limit.....	39
6.8. Transient Frequency Behavior.....	40
6.8.1. Test Setup.....	40
6.8.2. Test Result	41
6.8.3. Test Limit.....	43

6.9. Adjacent Channel Power..... 44
 6.9.1. Test Setup (Analog)..... 44
 6.9.2. Test Setup (Digital)..... 45
 6.9.3. Test Result 45
 6.9.4. Test Limit..... 46
 6.10. Conducted Spurious Emission 48
 6.10.1. Test Setup..... 48
 6.10.2. Test Result (Analog)..... 49
 6.10.1. Test Result (Digital)..... 62
 6.10.2. Test Limit..... 109
 6.11. Radiated Spurious Emission 110
 6.11.1. Test Setup..... 110
 6.11.2. Test Result 111
 6.11.3. Test Limit..... 111
 6.12. Effective Radiated Power (ERP) / GNSS (EIRP for 1559 - 1610MHz)..... 112
 6.12.1. Test Setup..... 112
 6.12.2. Test Result 112
 6.12.3. Test Limit..... 113
 6.13. AC Power Line Conducted Spur Emissions 114
 6.13.1. Test Setup..... 114
 6.13.2. Test Result 114
 6.13.3. Test Limit..... 115

Report Revision History

Revision History	Description	Date	Originator
Rev. A	Initial Report	27-JUL-2017	Song Zhi Wei
Rev. B	Amend on Occupied Bandwidth Result Format and Result.	17-AUG-2017	Song Zhi Wei
Rev. C	I. Amend on Occupied Bandwidth Part 22 16K0F3E plot for 459.125MHz. II. Remove Conducted Spurious Emission Part 22 and 74 from the title of the plot for 511.9875MHz.	24-AUG-2017	Song Zhi Wei

1.0 General Information

EUT Description:

Technologies	Land Mobile Radio (LMR)
Modulation Type	Analog, C4FM,Phase 2

General Description of Applied Standards

The EUT is a RF Product. According to the specifications of the manufacturer, the EUT is to comply with the requirements of the following standards:

ANSI/TIA/-603-D
ANSI C63.4.2014
TIA-102 CCAA-A
TIA-102 CAAB-D
TIA-102 CAAA-D
ANSI C63.26-2015

2.0 Summary of Test Results

FCC General Rules Part (47CFR)	IC General Rules Part	Test Item	Result
2.1046(a), 22.565(f), 74.461, 74.467, 80.215	RSS-Gen, RSS-119	RF Power Output	Pass
2.1055, 22.355, 74.464, 74.561	-	Frequency Stability	Pass
2.107,74.463	-	Audio Frequency Response	Pass
2.107,74.463	-	Audio Low Pass Filter Response	Pass
2.107,74.463	-	Modulation limiting	Pass
2.1049, 22.359, 90.210, 74.462(b), 74.535, 80.211(c), (f)	RSS-Gen, RSS-119	Occupied Bandwidth	Pass
22.359(a),(b)	-	Band Edge Conducted Spurious Emission	Pass
90.214	-	Transient Frequency Behavior	Pass
-	-	Adjacent Channel Power	NA
2.1051, 22.359, 74.462(c), 80.211(c)	RSS-Gen, RSS-119	Conducted Spurious Emissions	Pass
2.1051, 22.359, 74.462(c), 80.211(c)	RSS-Gen, RSS-119	Radiated Spurious Emission	NA
-	-	GNSS (EIRP for 1559 – 1610MHz)	NA
-	-	Effective Radiated Power (ERP)	NA
-	-	AC Power Line Conducted Spurious Emission	NA

NA → Not Applicable

3.0 Measurement Uncertainty

Measurement	Frequency	Expanded Uncertainty (k=1.96) (±)
AC Power Line Conducted Spurious Emission	150KHz ~ 30MHz	3.43
Radiated Emissions up to 1 GHz	30MHz ~ 200MHz	5.01
	200MHz ~ 1000MHz	5.01
Radiated Emissions above 1 GHz	1GHz ~ 18GHz	5.01
	18GHz ~ 25GHz	5.01

4.0 Equipment List

FCC Analog ATE#1: (SW Version: Analog ATE_Rev 2.4.2 & FCC_FreqStability_Rev 1.0.3)

Description	Model	Serial Number	Calibration Date	Calibration Due Date
Audio Analyzer	8903B	3011A10475	2-May-17	2-May-18
SIGNAL GENERATOR	2042	203002/745	2-May-17	2-May-18
MODULATION ANALYZER	8901B	3216A03889	3-May-17	3-May-18
TRANSCEIVER INTERFACE	8954A	2234A00398	4-May-17	4-May-18
DSA	36570A	MY42506781	3-May-17	3-May-18
SIGNAL GENERATOR	E4425B	US39260201	2-May-17	2-May-18
SIGNAL GENERATOR	2042	203002/747	2-May-17	2-May-18
POWER SENSOR	E4412A	MY41502652	9-May-17	9-May-18
POWER METER	E4416A	GB41293855	9-May-17	9-May-18
POWER SUPPLY	6031A	3325A02771	3-May-17	28-Mar-18
CHAMBER	SH-641	92014678	4-Apr-17	4-Mar-18
RF TRANSCEIVER CONTROLLER	AX2007AI	NA	CNR	CNR

FCC Transient ATE #1: (SW Version: FCC Transient ATE_R 1.0.3)

Description	Model	Serial Number	Calibration Date	Calibration Due Date
POWER SUPPLY	6032A	2818A03549	11-May-17	11-May-18
POWER SENSOR	E4412A	MY41498918	9-May-17	9-May-18
POWER METER	E4416A	MY45101016	11-Jan-17	11-Jan-18
ATTENUATORS/SWITCH DRIVER	11713A	2508A10141	CNR	CNR
STEP ATTENUATOR/11dB	8494G	MY52300223	9-May-17	9-May-18
STEP ATTENUATOR/110dB	8496G	MY52300176	9-May-17	9-May-18
OSCILLOSCOPE	MSO8064A	MY48240107	25-May-17	25-May-18
AUDIO ANALYZER	8903B	3729A17409	2-May-17	2-May-18
AUDIO ANALYZER	8903B	3011A08952	2-May-17	2-May-18
MODULATION ANALYZER	8901B	3019A02766	4-Mar-17	4-Mar-18
SIGNAL GENERATOR	8657A	3323A05725	2-May-17	2-May-18
SPECTRUM ANALYZER	E4440A	MY46185415	24-May-17	24-May-19
SWITCH CONTROL UNIT	-	-	CNR	CNR

Conducted Spurious Emission ATE # 1: (SW Version: Conducted Spur ATE_rev 1.22.07)

Description	Model	Serial Number	Calibration Date	Calibration Due Date
SWITCH CONTROL UNIT	3488A	2719A32735	CNR	CNR
SPECTRUM ANALYZER	E4440A	US45303111	16-Feb-17	16-Feb-18
POWER SUPPLY	6032A	MY41002067	5-May-17	5-May-18
HIGH PASS FILTER SWITCH BOX	-	CS001	7-Apr-17	7-Apr-18
MICROWAVE GENERATOR	SMP 02	830682/015	19-Oct-16	19-Oct-17
MODULATION ANALYZER	8901B	3438A05278	3-Mar-17	3-Mar-18

CNR → Calibration Not Required

5.0 Test Condition

5.1. Transmitter Test Conditions

Test Item, (Channel Spacing)	Temperature (°C)	Voltage Supply (V)	Power (W)	Modulation	Test Frequency (MHz)
RF Output Power	25°C	Nominal	Low / Max	Analog	450.6500, 459.1250, 467.7750, 511.9875
Frequency Stability	-30°C ~ 60°C	80% ~ 120% of Nominal Volt	Max	Analog	467.7750
Audio Frequency Response (12.5kHz / 25kHz)	25°C	Nominal	Max	Analog	467.7750, 511.9875
Audio Low Pass Filter Response (12.5kHz / 25kHz)	25°C	Nominal	Max	Analog	467.7750, 511.9875
Modulation limiting (12.5kHz / 25kHz)	25°C	Nominal	Max	Analog	467.7750, 511.9875
Occupied Bandwidth (12.5kHz / 20kHz / 25kHz)	25°C	Nominal	Max	Analog, Digital	450.6500, 459.1250, 467.7750, 473.01250, 511.9875
Band Edge Conducted Spurious Emission (12.5kHz / 20kHz / 25kHz)	25°C	Nominal	Max	Analog, Digital	459.0250, 459.6500, 473.0125, 479.2875
Transient Frequency Behavior (UHF & VHF Band) (12.5kHz / 25kHz)	25°C	Nominal	Max	Analog, Digital	467.7750
Adjacent Channel Power (700MHz Band) (12.5kHz / 25kHz)	25°C	Nominal	Max	NA	NA
Conducted Spurious Emissions (12.5kHz / 20kHz / 25kHz)	25°C	Nominal	Low / Max	Analog, Digital	450.6500, 459.02500, 459.6500, 467.7750, 482.0125, 473.0125, 479.2875, 511.9875
Radiated Spurious Emission (12.5kHz / 25kHz)	25°C	Nominal	Low / Max	Analog, Digital	450.6500, 459.02500, 459.6500, 467.7750, 482.0125, 473.0125, 479.2875, 511.9875
GNSS (700MHz Band) (EIRP for 1559-1610MHz) (12.5kHz / 25kHz)	25°C	Nominal	Max	NA	NA
Effective Radiated Power (ERP) (700MHz & 900MHz Band) (12.5kHz / 25kHz)	25°C	Nominal	Max	NA	NA
AC Power Line Conducted Spurious Emissions* (12.5kHz)	25°C	Nominal	Max	NA	NA

* – ONLY tested if portables can be operated during charging OR mobiles can be used in desktop operation connected to a power supply **NA → Not Applicable**

6.0 Transmitter Test Parameters

6.1. RF Output Power

6.1.1. Test Setup

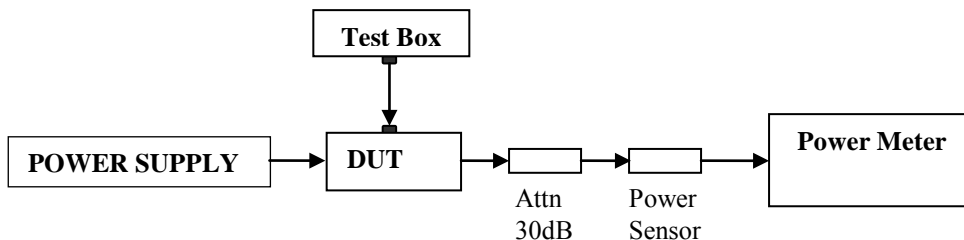

- 1) The DUT transmitter connected to Power Meter using the 30 dB attenuator and power sensor with above setup.
- 2) Path loss for the measurement included.
- 3) All the measurement was done at low, mid, high frequency for each band.
- 4) Record the power into the test report.

6.1.2. Test Result

Temperature	25°C				Remarks
Voltage (V)	7.5V				
Frequency (MHz)	Low Power (W)	Current (A)	Max Power (W)	Current (A)	
450.6500	1.03	0.90	5.40	2.03	
459.1250	1.03	0.90	5.41	2.05	
467.7750	1.00	0.87	5.45	2.06	
511.9875	1.03	0.91	5.54	2.09	
519.9875	1.05	0.95	5.59	2.10	Not For FCC Review

6.2. Frequency Stability

6.2.1. Test Setup

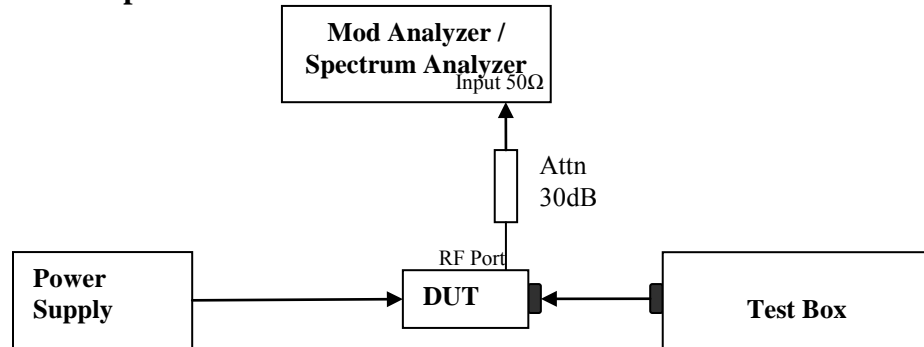

- 1) The DUT transmitter output port was connected to Modulation Analyzer.
- 2) Path loss for the measurement included.
- 3) Transmit the DUT and record the freq in MCF_{MHz} .
- 4) Test in 2 conditions: Different Temperature & Supply Voltage input.
 - Temperature: Vary voltage per test condition in Clause 5.1
 - Supply Voltage: Vary temperature per test condition in Clause 5.1
- 5) Calculate the ppm frequency error by the following:

$$ppm\ error = \left(\frac{MCF_{MHz}}{ACF_{MHz}} - 1 \right) * 10^6$$

Where: MCF_{MHz} is the Measured Carrier Frequency in MHz
 ACF_{MHz} is the Assigned Carrier Frequency in MHz

6.2.2. Test Result

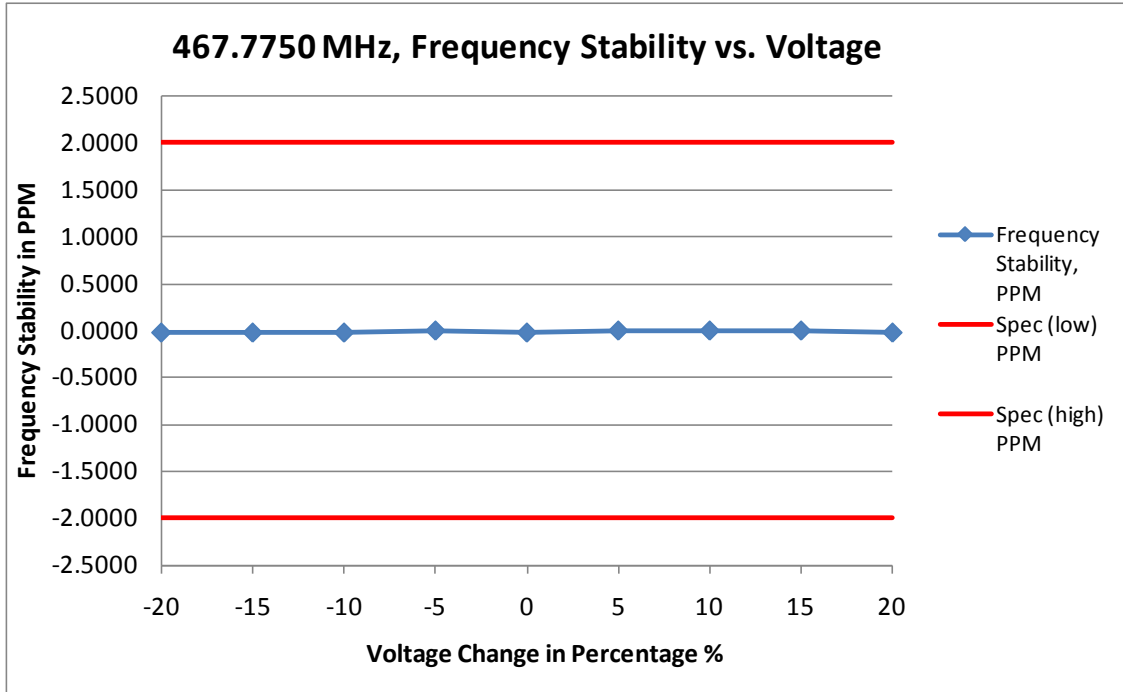

(i) Frequency Stability VS Voltage

Frequency / Channel Spacing		467.7750 MHz / 25.00 kHz			
Temperature, °C		25			
Voltage %	Voltage, V	Frequency, MHz	Frequency Stability, PPM	Spec (low) PPM	Spec (high) PPM
-20	6.0000	467.7750	-0.0214	-2.0000	2.0000
-15	6.3750	467.7750	-0.0214	-2.0000	2.0000
-10	6.7500	467.7750	-0.0214	-2.0000	2.0000
-5	7.1250	467.7750	0.0000	-2.0000	2.0000
0	7.5000	467.7750	-0.0214	-2.0000	2.0000
5	7.8750	467.7750	0.0000	-2.0000	2.0000
10	8.2500	467.7750	0.0000	-2.0000	2.0000
15	8.6250	467.7750	0.0000	-2.0000	2.0000
20	9.0000	467.7750	-0.0214	-2.0000	2.0000

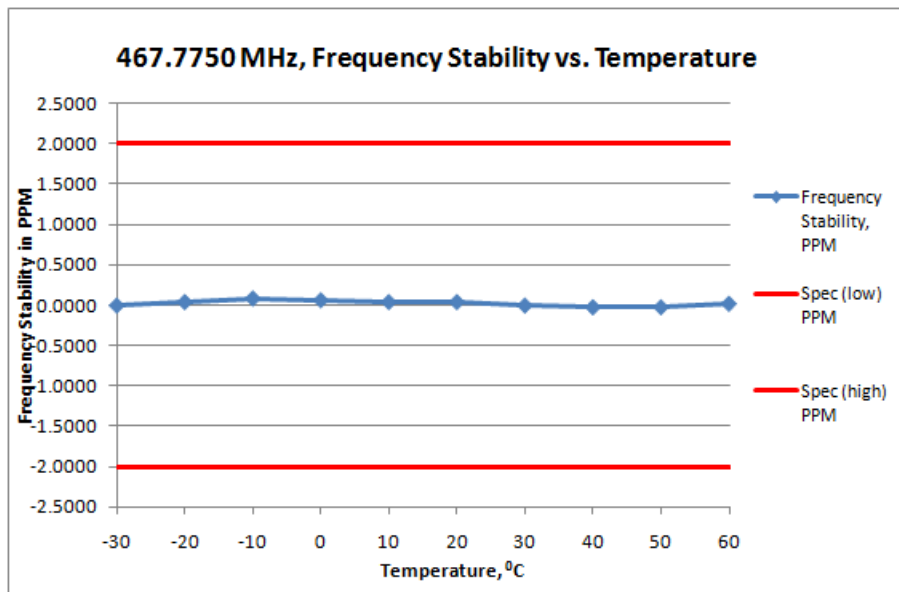

(ii) Frequency Stability VS temperature

Frequency / Channel Spacing		467.7750 MHz / 25.00 kHz		
Voltage, V		7.5000		
Temperature, °C	Frequency, MHz	Frequency Stability, PPM	Spec (low) PPM	Spec (high) PPM
-30	467.7750	0.0000	-2.0000	2.0000
-20	467.7750	0.0428	-2.0000	2.0000
-10	467.7750	0.0855	-2.0000	2.0000
0	467.7750	0.0641	-2.0000	2.0000
10	467.7750	0.0428	-2.0000	2.0000
20	467.7750	0.0428	-2.0000	2.0000
30	467.7750	0.0000	-2.0000	2.0000
40	467.7750	-0.0214	-2.0000	2.0000
50	467.7750	-0.0214	-2.0000	2.0000
60	467.7750	0.0214	-2.0000	2.0000

6.2.3. Test Limit

As per manufacturer declared spec +/- 2ppm

6.3. Audio Frequency Response

6.3.1. Test Setup

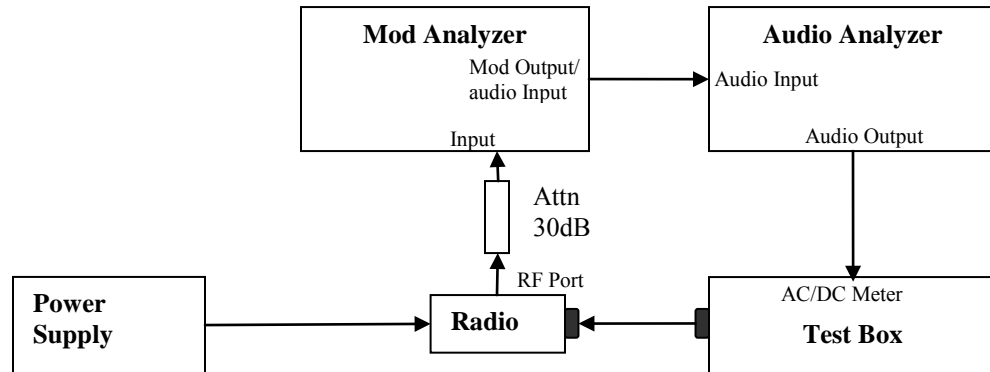

- 1) The DUT transmitter output port was connected to Modulation Analyzer.
- 2) Path loss for the measurement included.
- 3) Set the audio bandwidth filter to 15 kHz and 50 kHz.
- 4) Transmit the radio and set the audio analyzer to 1 kHz audio frequency and 20% of the maximum deviation.
- 5) On audio analyzer, set the rated level as reference to zero.
- 6) Vary the audio frequency from 300 Hz to 3 kHz. Record the change in dB on the audio analyzer.

6.3.2. Test Result

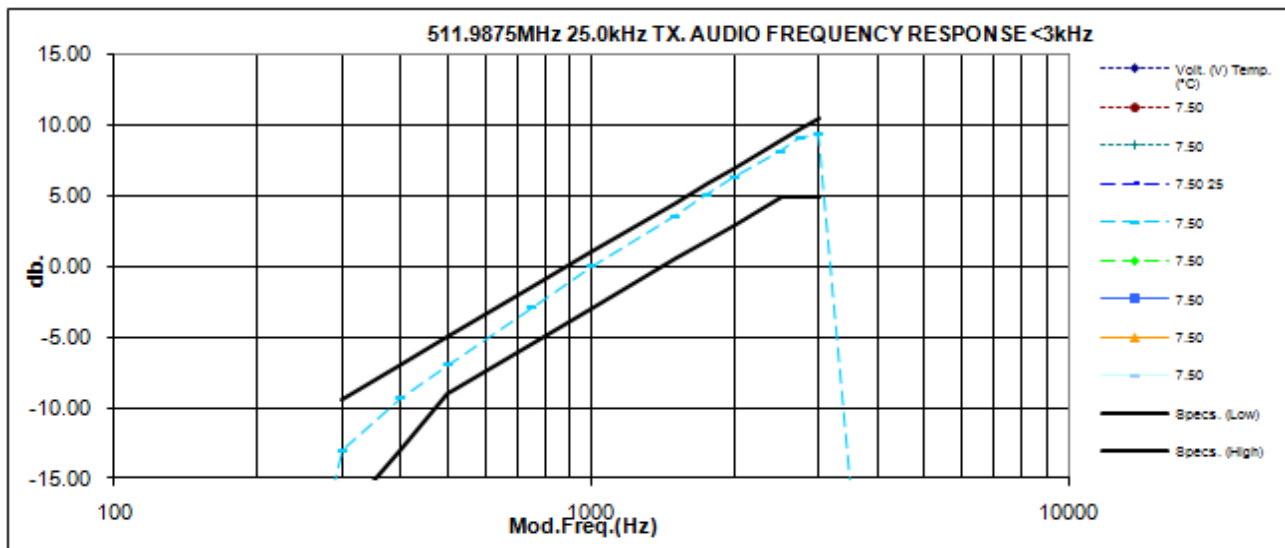
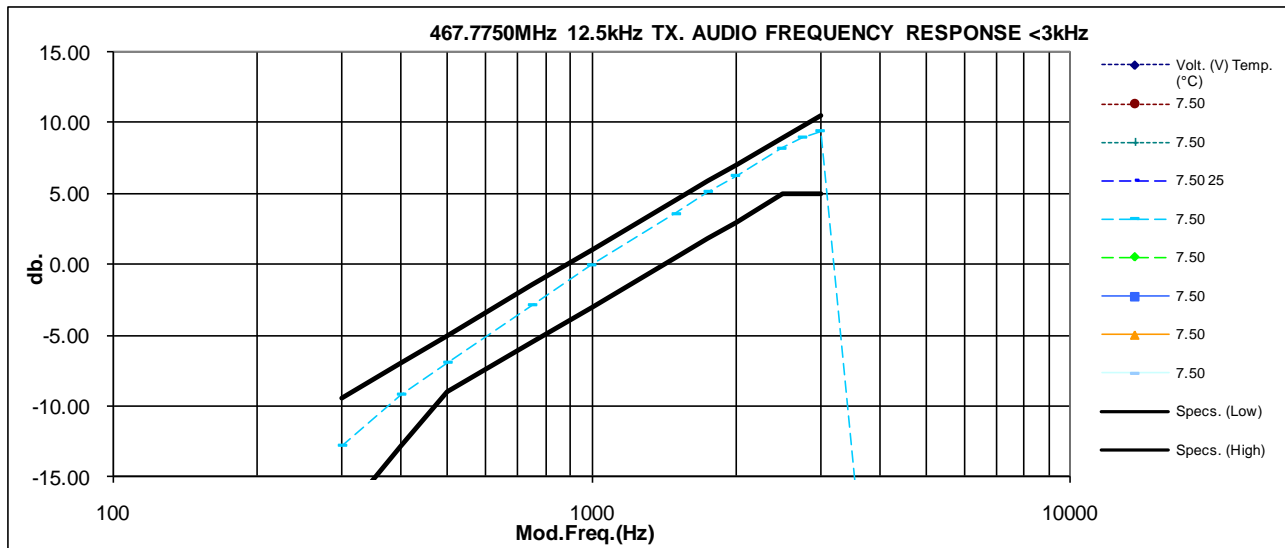

6.3.3. Test Limit

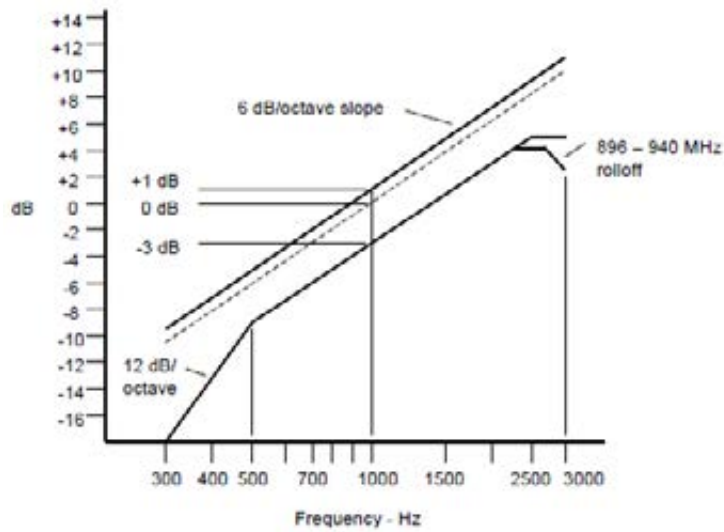

Note:

- o There are additional 6 dB per octave attenuation is allowed from 2.5KHz to 3KHz in equipment 25MHz to 869MHz radio.
- o Additional 6 dB per octave attenuation is allowed from 2.3KHz to 2.7KHz & additional 12 dB per octave attenuation is allowed from 2.7KHz to 3KHz in equipment 896MHz to 940MHz radio.

6.4. Audio Low Pass Filter Response

6.4.1. Test Setup

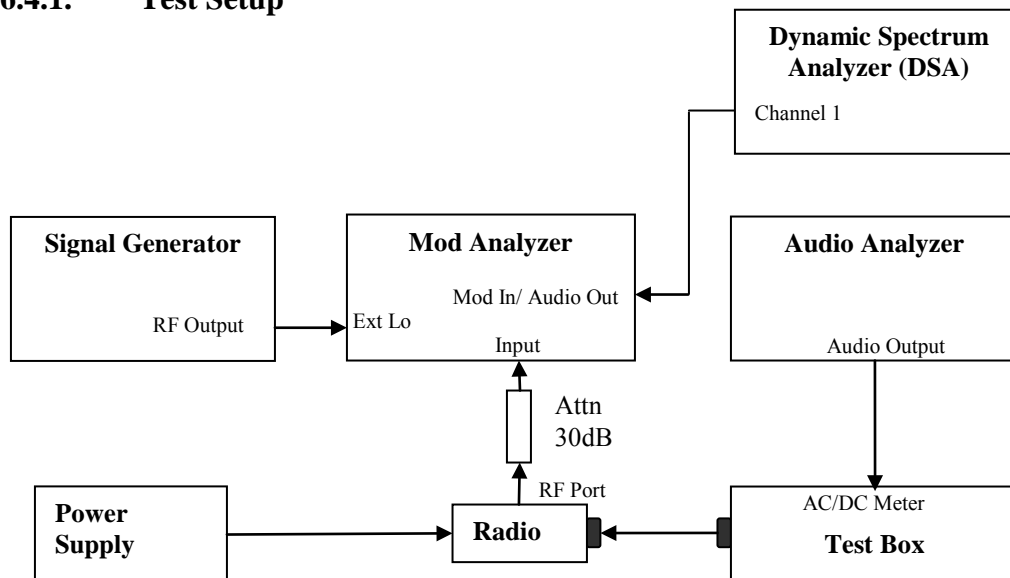

- 1) The DUT transmitter output port was connected to Modulation Analyzer.
- 2) Path loss for the measurement included.
- 3) Press 23.1SPCL on modulation analyzer to enable the external LO from Sigen.
- 4) Set the Sigen frequency to $F_c + 1.5$ MHz, RF output level to 0dBm without modulation.
- 5) Transmit the radio and set the audio analyzer to 1 kHz audio frequency and 60% of the maximum deviation.
- 6) Up the amplitude by 20dB.
- 7) On DSA, get the reference point to 0dB.
- 8) Vary the frequency on audio analyzer from 3 kHz to 20 kHz, record the audio tone from DSA.

6.4.2. Test Result

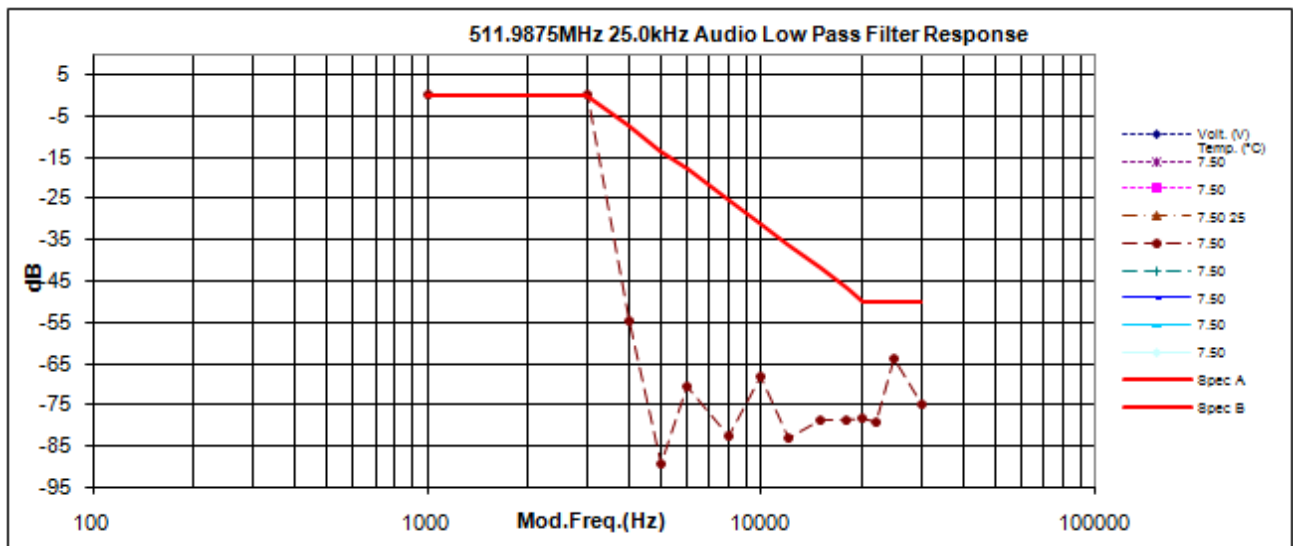
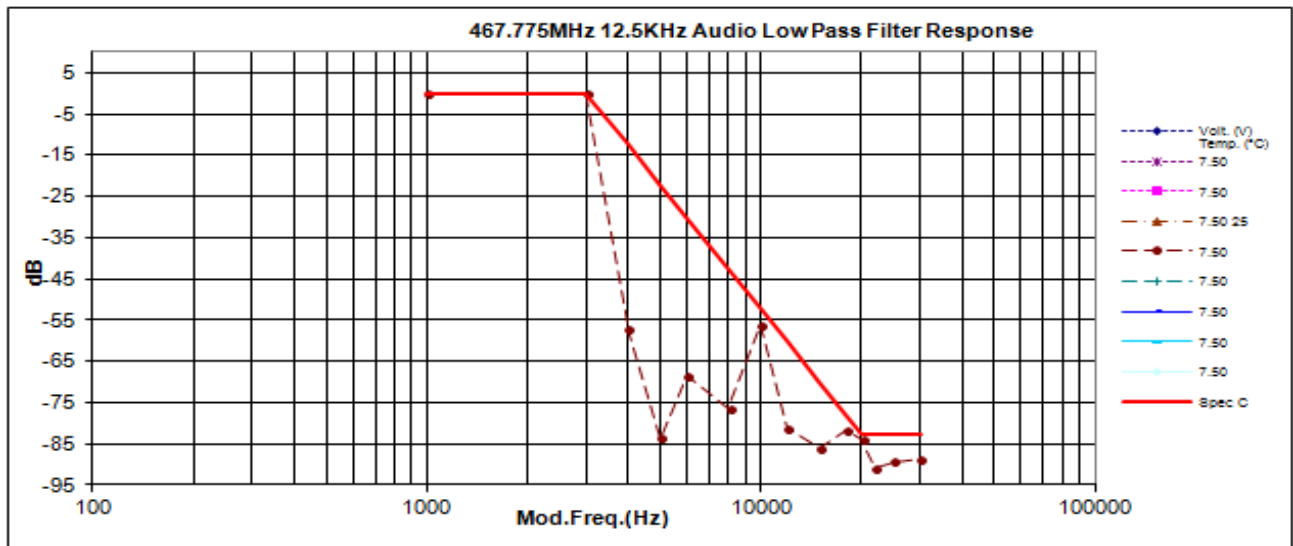

6.4.3. Test Limit

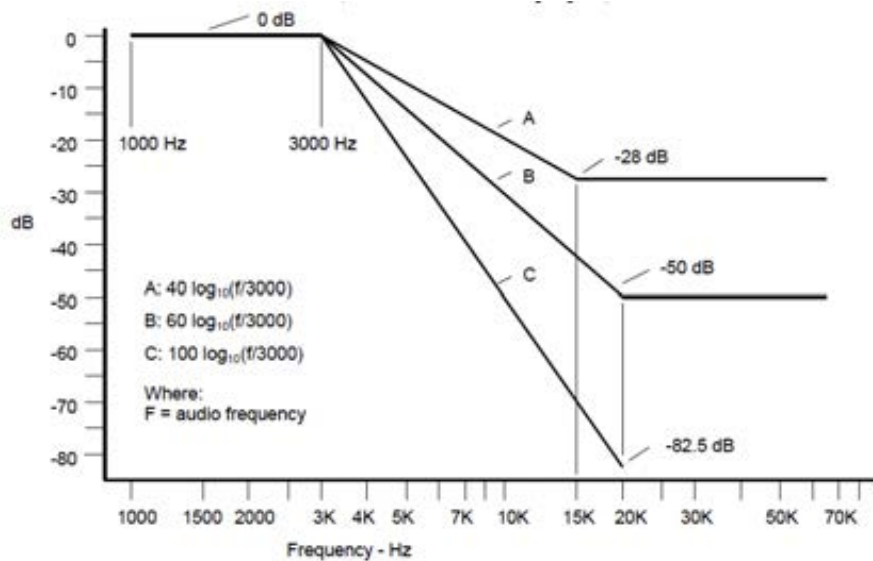

For audio frequencies above 3000 Hz, the audio response of the post limiter low-pass filter shall meet or exceed the following requirements:

- a) For equipment operating on 20, 25 or 30 kHz channel bandwidth in the 25 MHz to 174 MHz range:

At frequencies from 3000 Hz through 15,000 Hz the attenuation shall be greater than the attenuation at 1000 Hz by at least: $40 \log_{10}(f/3000)$ dB

where: f is the audio frequency in Hz.

At frequencies above 15,000 Hz, the attenuation shall be greater than the attenuation at 1000 Hz, by at least: 28 dB.

- b) For equipment operating with 25 kHz bandwidth channels between 406 and 512 MHz through 896 MHz, and between 929 MHz through 930 MHz:

At frequencies from 3000 Hz through 20,000 Hz, the attenuation shall be greater than the attenuation at 1000 Hz by at least: $60 \log_{10}(f/3000)$ dB

where: f is the audio frequency in Hz.

At frequencies above 20,000 Hz the attenuation shall be greater than the attenuation at 1000 Hz by at least: 50 dB.

- c) For equipment operating on channels between 896 MHz through 901 MHz, between 935 MHz through 940 MHz, and 12.5 or 15 kHz spaced channels in the frequency range 138-174 MHz and 406-512 MHz.

At frequencies from 3000 Hz through 20,000 Hz the attenuation shall be greater than the attenuation at 1000 Hz by at least: $100 \log_{10}(f/3000)$ dB

where: f is the audio frequency in Hz.

6.5. Modulation Limiting

6.5.1. Test Setup

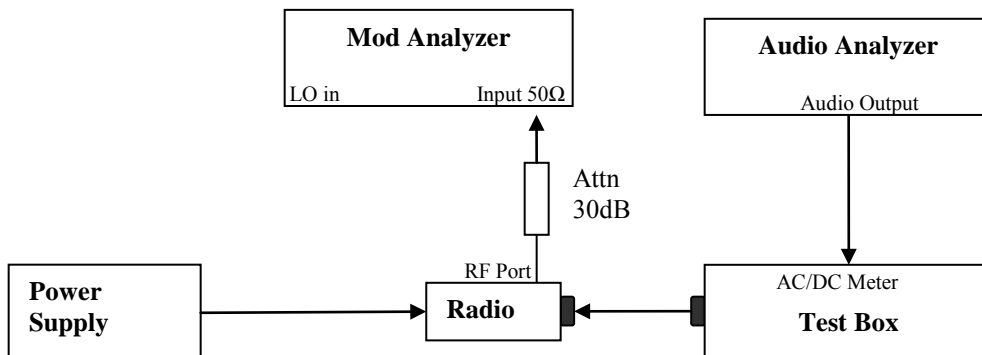

- 1) The DUT transmitter output port was connected to Modulation Analyzer.
- 2) Path loss for the measurement included.
- 3) Set the audio bandwidth filter to 15 kHz.
- 4) Transmit the radio and set the audio analyzer to 1 kHz audio frequency and 60% of the maximum deviation.
- 5) Record the frequency deviation as 0dB input level at 1kHz audio frequency.
- 6) Repeat the step and record the frequency deviation from -20 dB to 20dB by 5 dB increments and different audio freq 300 Hz, 2.5 kHz and 3 kHz.

6.5.2. Test Result

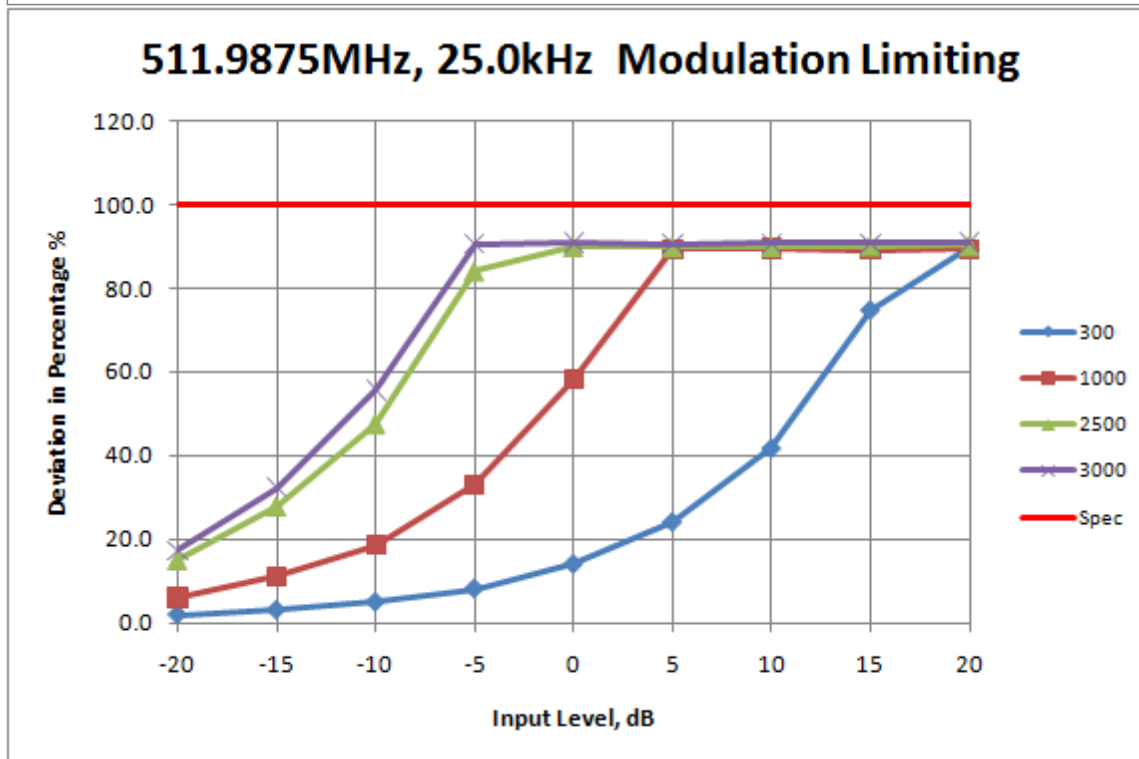
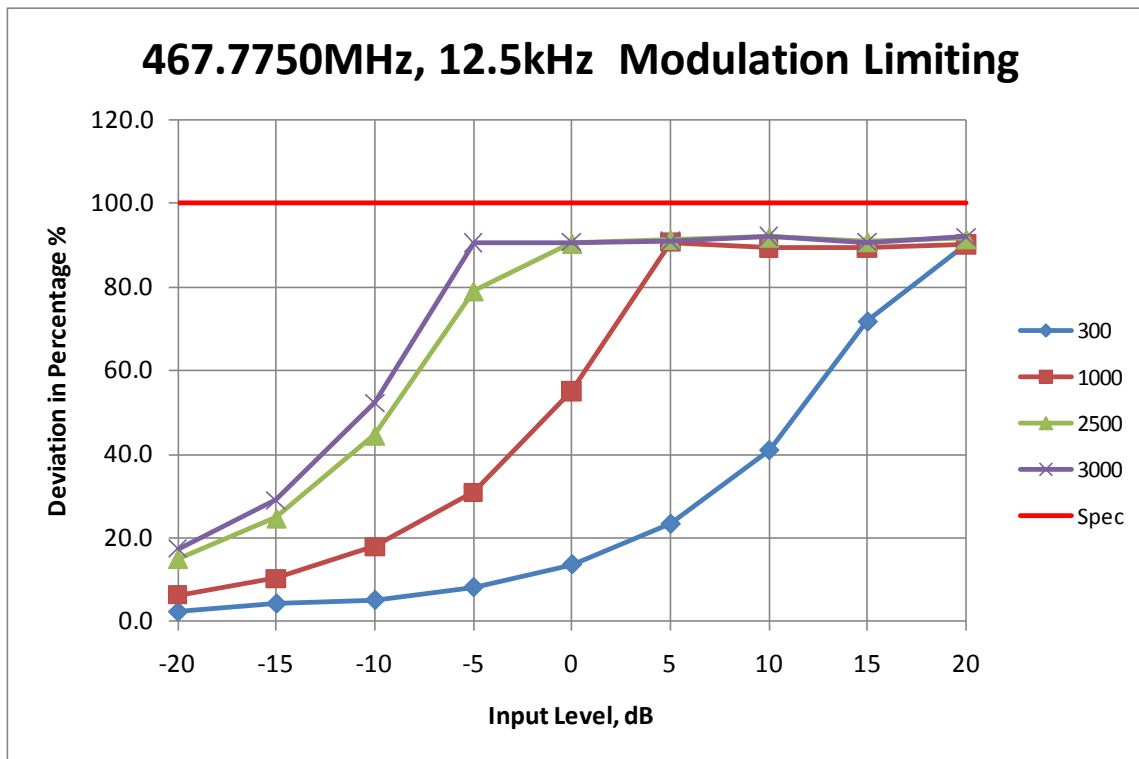

6.5.3. Test Limit

Modulation shall not exceed 100 percent if amplitude modulation is employed.

6.6. Occupied Bandwidth

6.6.1. Test Setup (Analog)

A. Get Fc for reference

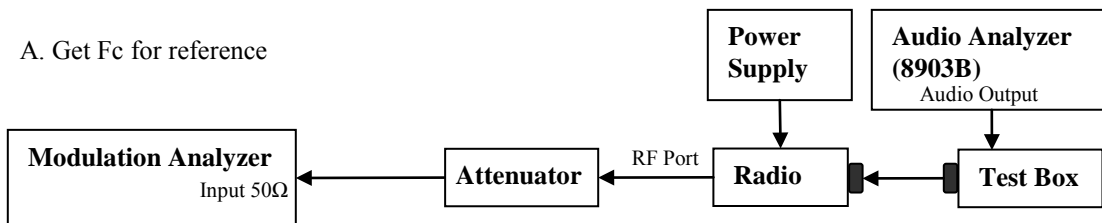

B. Testing

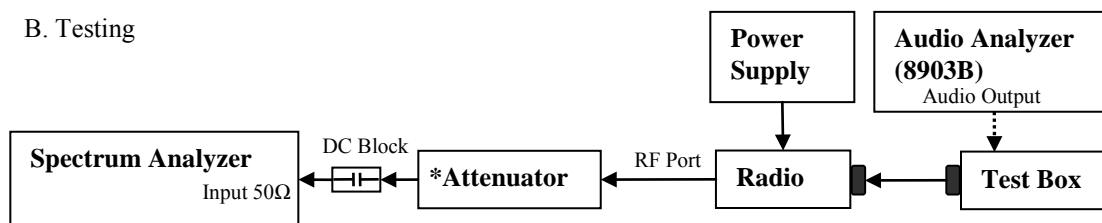

- 1) The DUT transmitter output port was connected to Modulation Analyzer.
- 2) Set the audio bandwidth filter to 15 kHz low pass filter and 50 kHz high pass filter.
- 3) Transmit the radio and set the audio analyzer to 2.5 kHz audio frequency and 50% of the rated deviation. Up the amplitude by 16 dB. Dekey the DUT.
- 4) Path loss for the measurement included.
- 5) Select the Occupied Bandwidth measurement for 99% Bandwidth Measurement.
- 6) Key in the Fc and Resolution Bandwidth (1 ~ 5 % of emission designator).
- 7) Transmit the DUT and record the occupied Bandwidth frequency.
- 8) Preset the spectrum analyzer for sideband spectrum measurement.
- 9) Set the span to 100 KHz and Resolution Bandwidth (according to FCC/ ISED standard).
- 10) Save the screen shot as modulated signal
- 11) Remove the audio tone from audio analyzer to capture unmodulated signal.

* Only HPF added for Mask 80.211 measurement with attenuator.

6.6.2. Test Result (Analog)

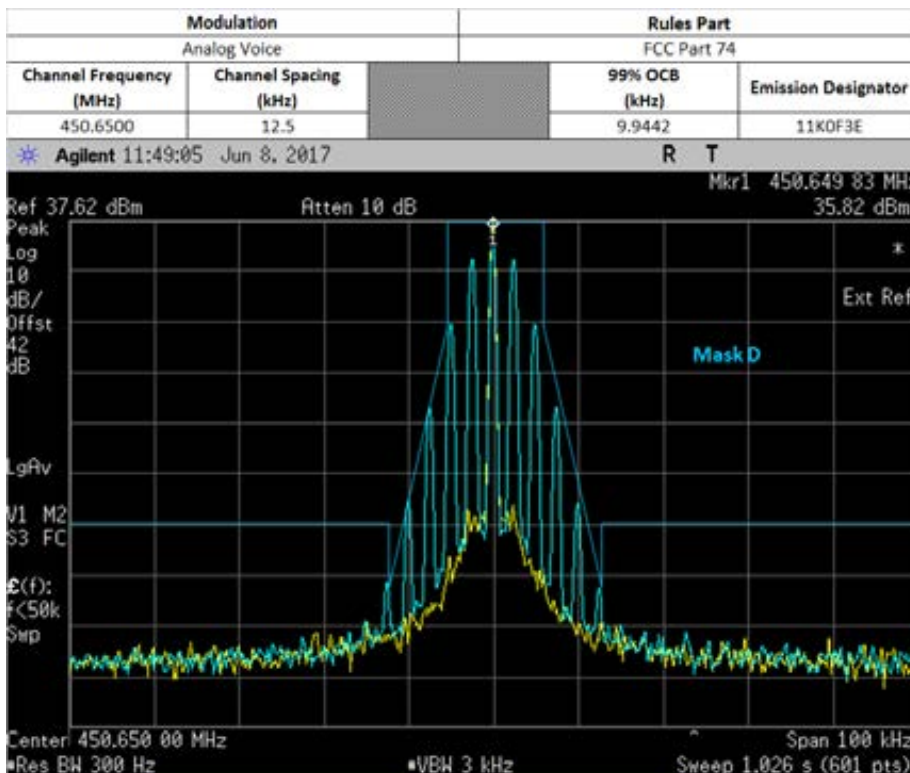
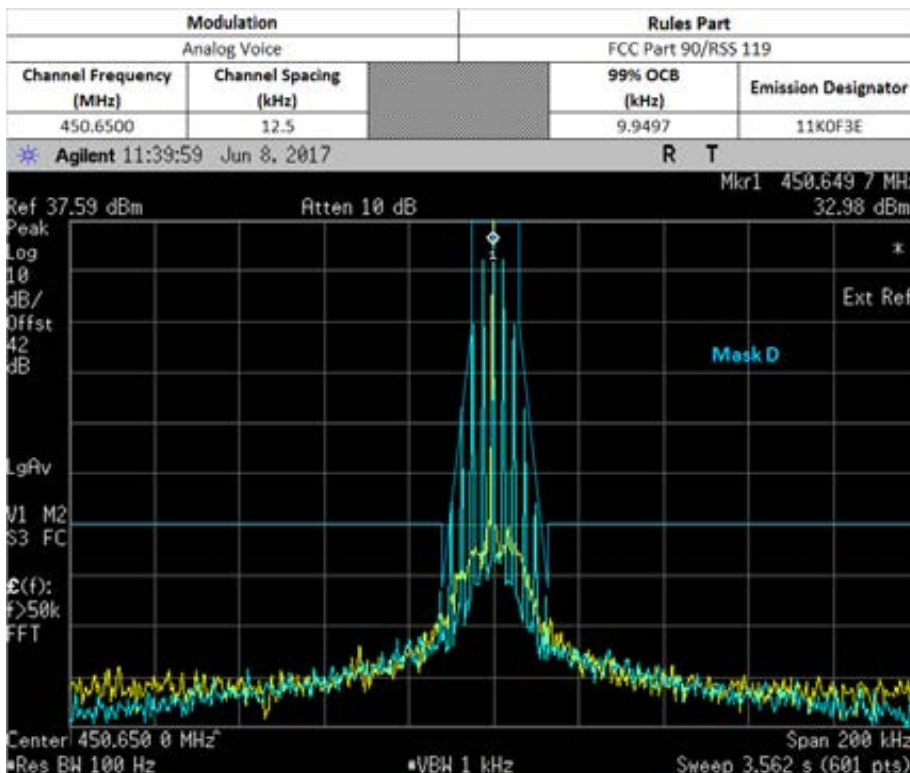

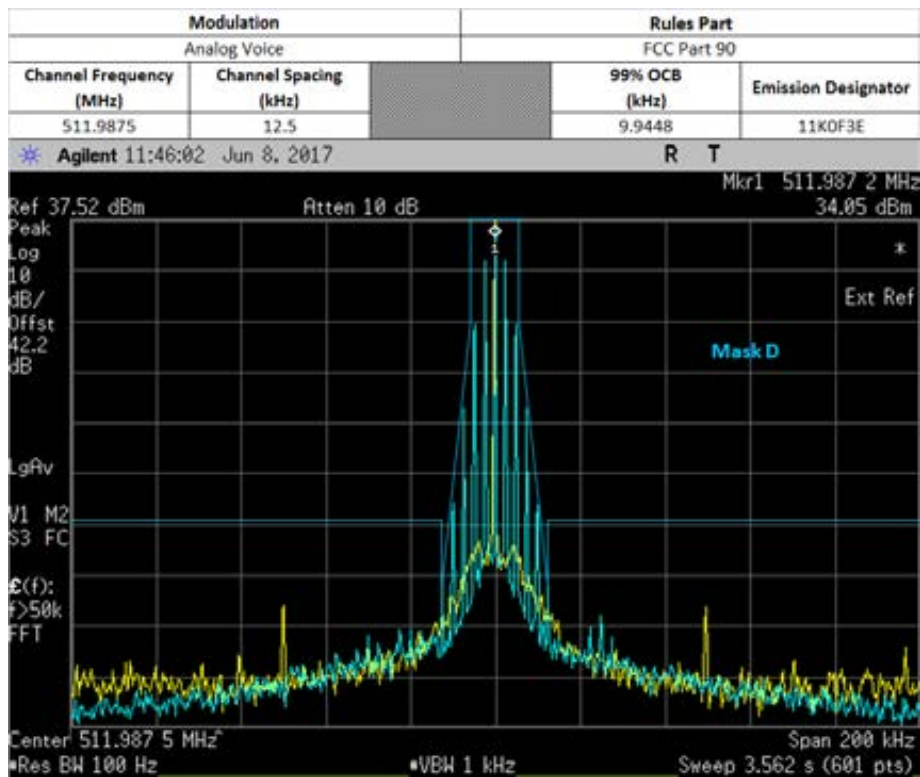
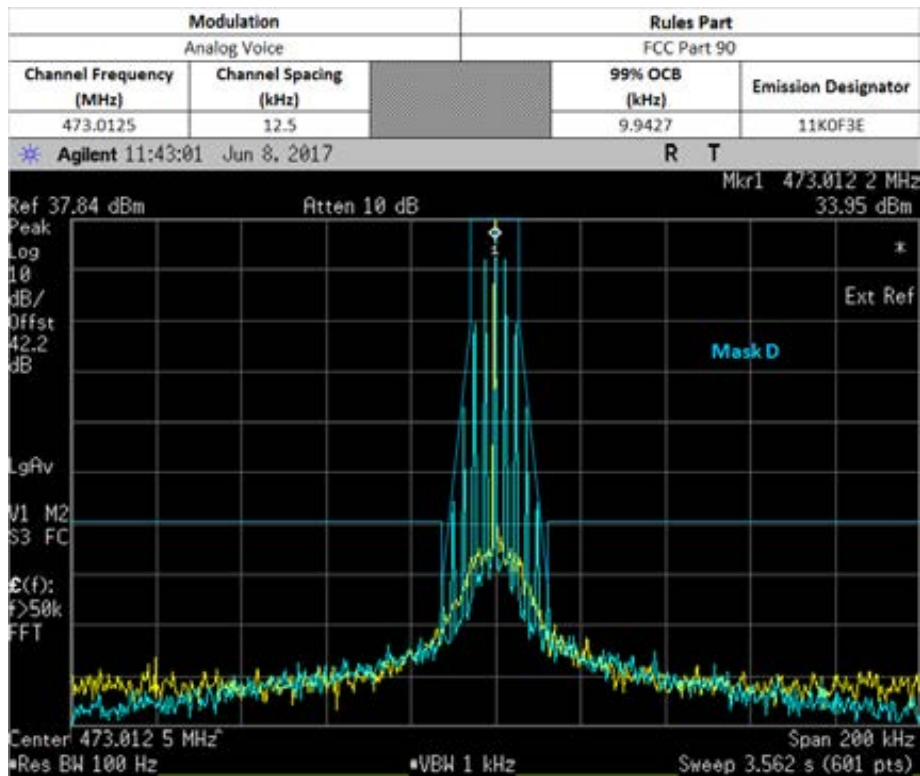

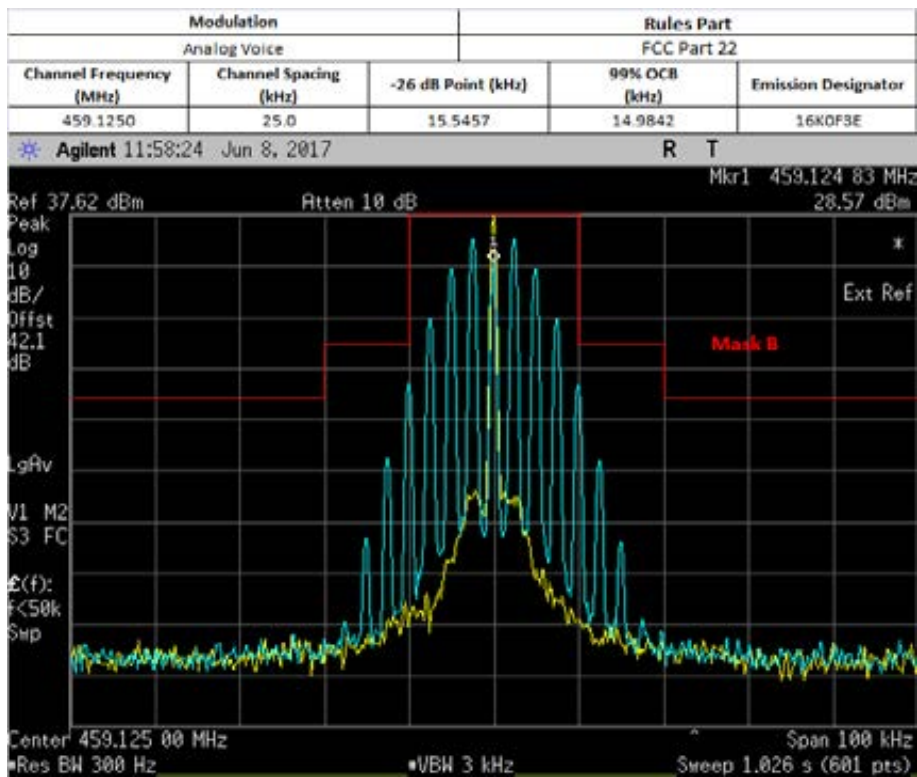
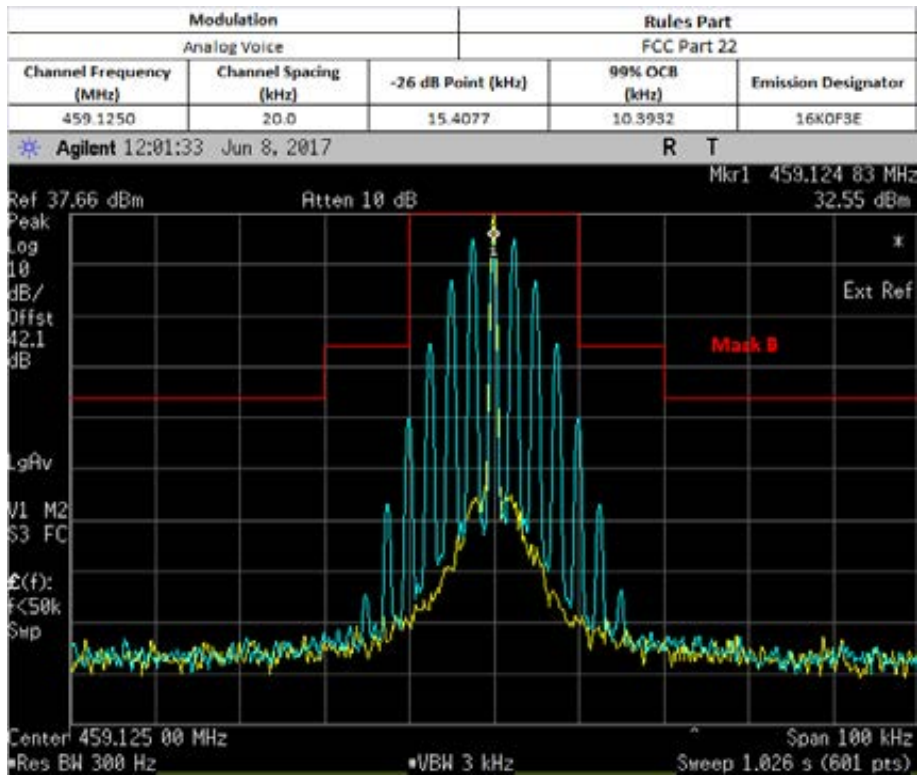

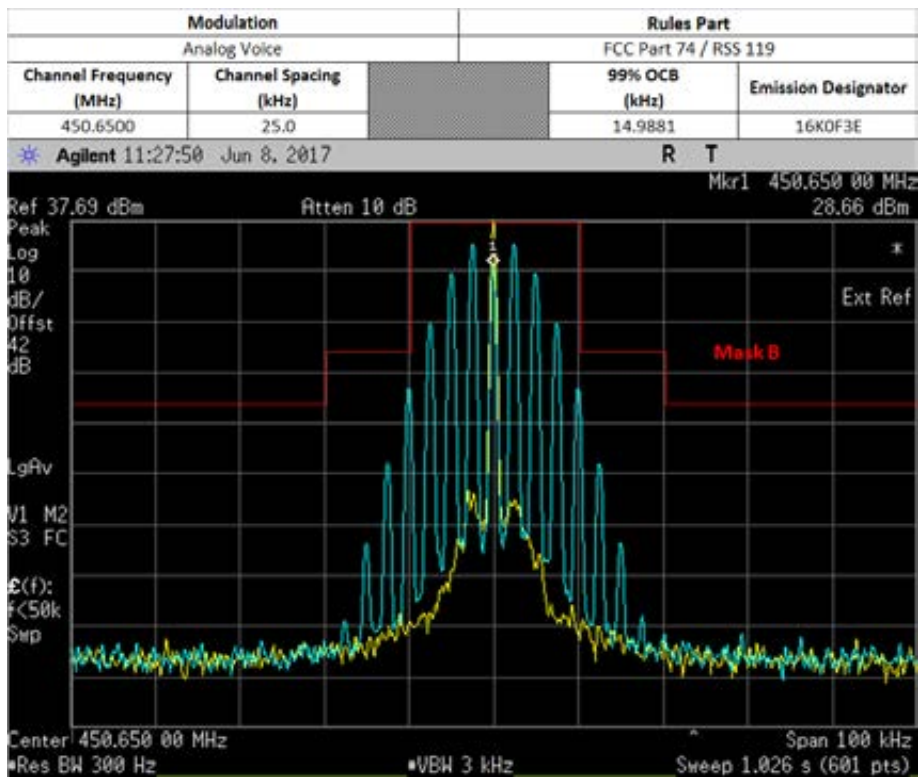
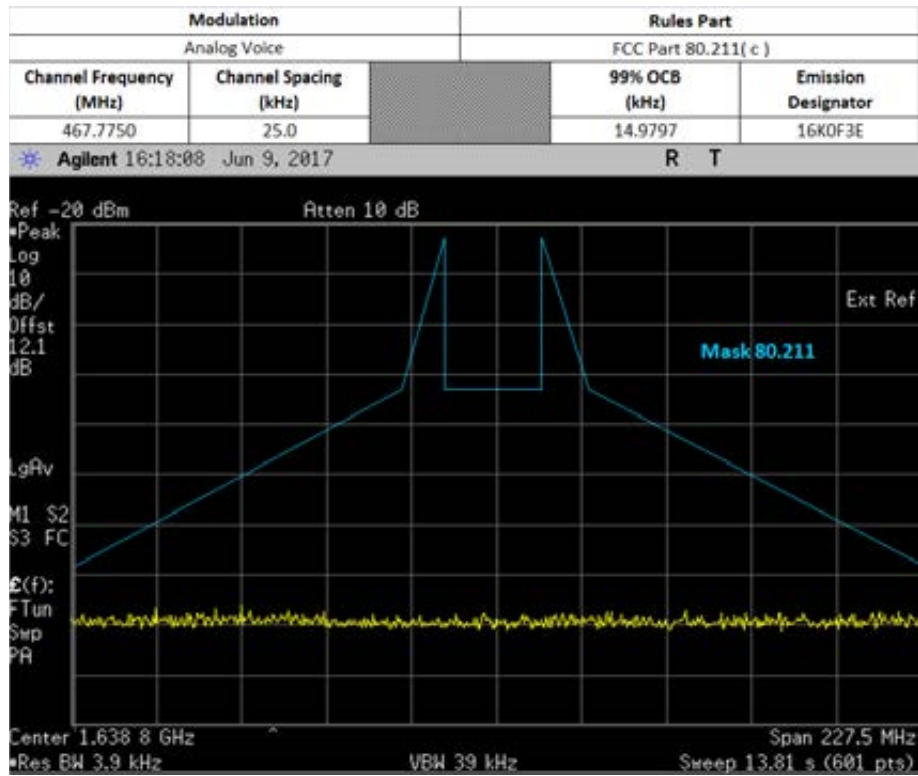

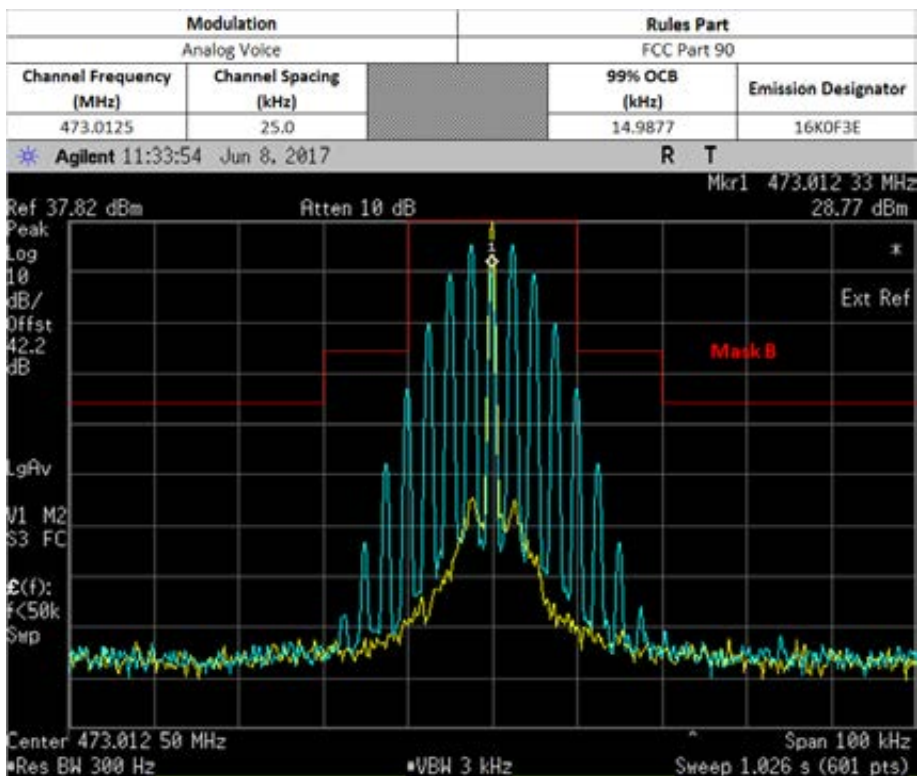
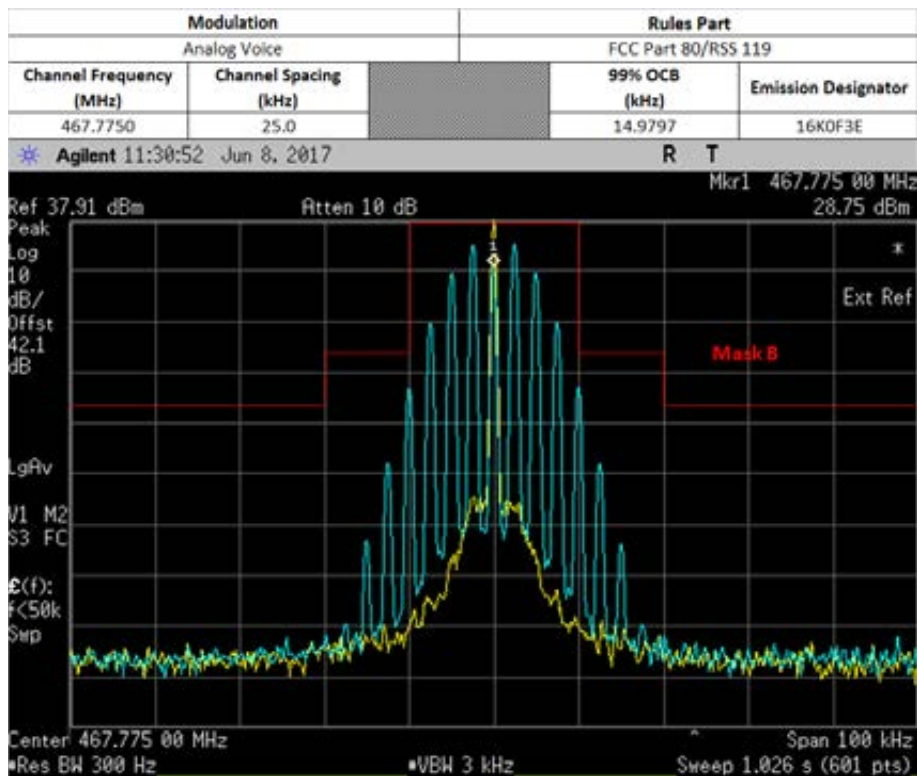

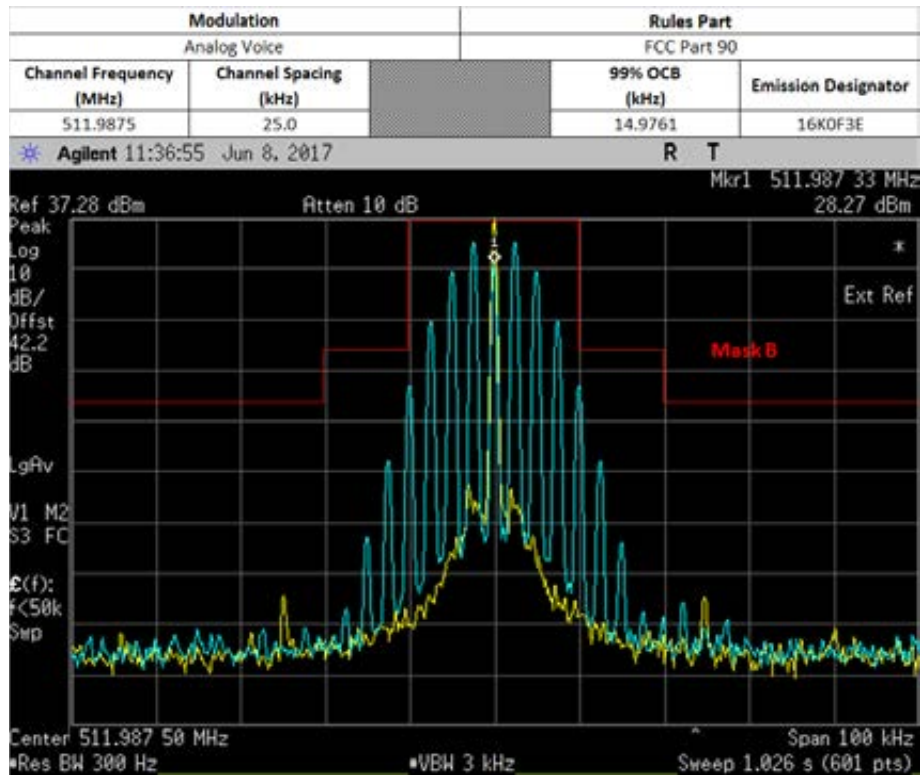

6.6.3. Test Setup (Digital)

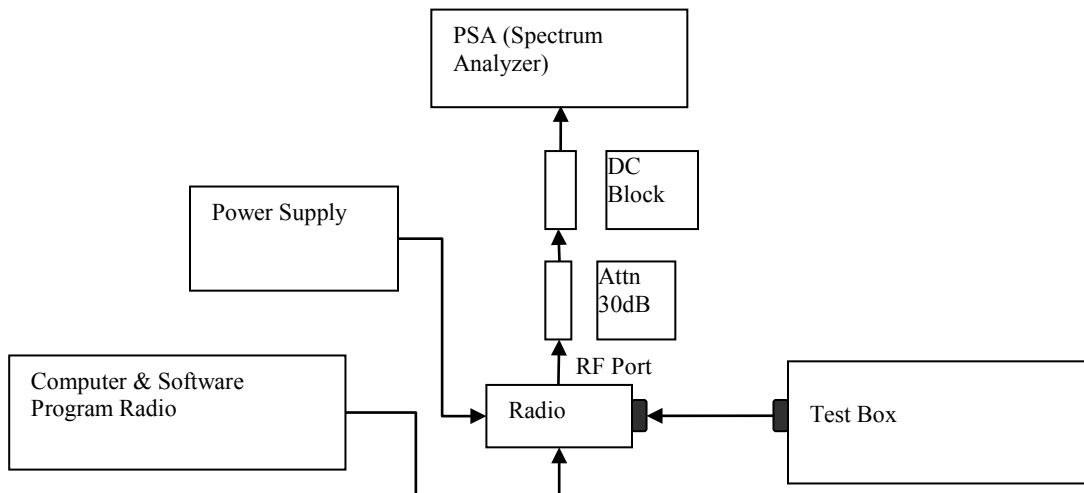

- 1) Program and set radio to operate in desire test frequency and digital mode with modulation. (4FSK, C4FM, CQPSK or other digital modulation form).
- 2) Path loss for the measurement included.
- 3) Select the Occupied Bandwidth measurement for 99% Bandwidth Measurement.
- 4) Key in the Fc and RBW (1 ~ 5 % of emission designator).
- 5) Transmit the DUT and record the occupied Bandwidth frequency.
- 6) Preset the spectrum analyzer for modulation emission spectrum measurement.
- 7) Set the span to 100 KHz and Resolution Bandwidth (according to FCC/ ISED standard).
- 8) Capture the screen shot as modulated signal.

6.6.4. Test Result (Digital)

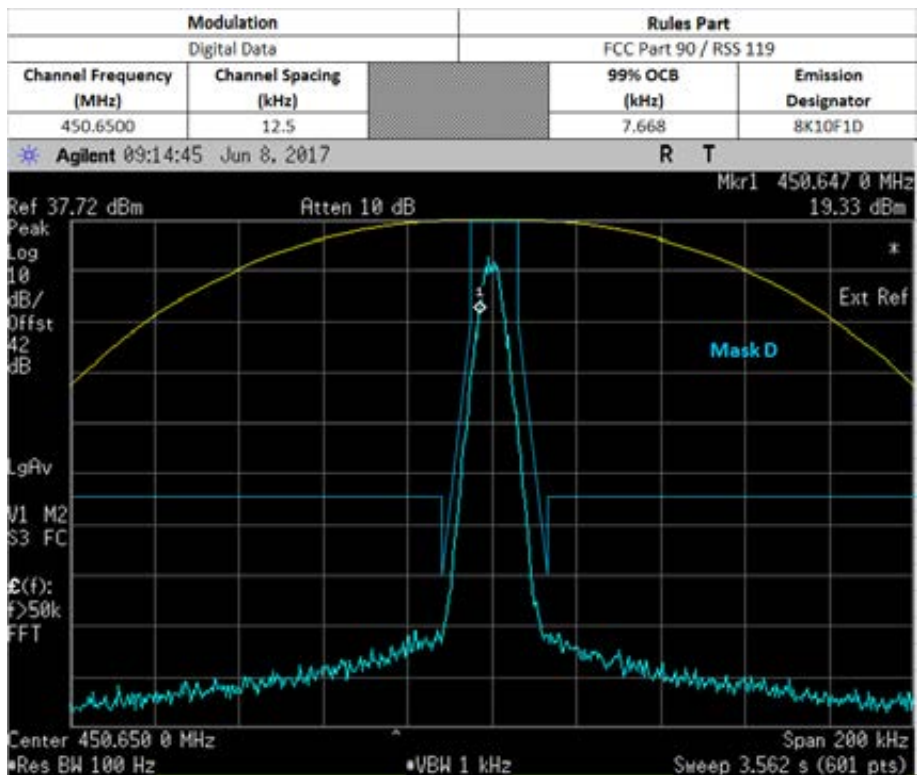
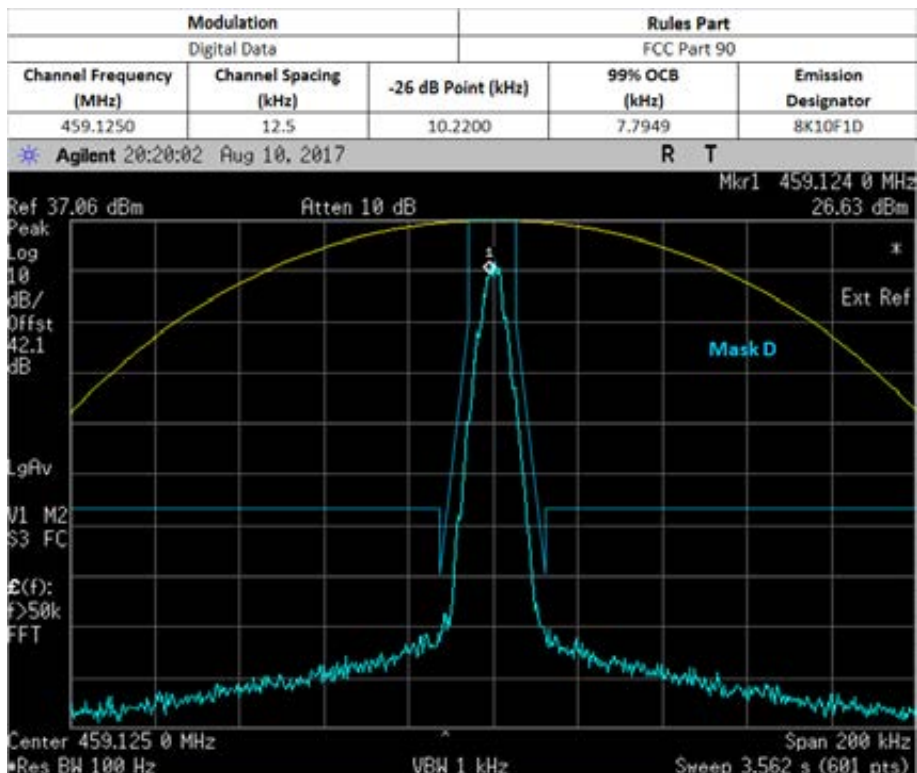

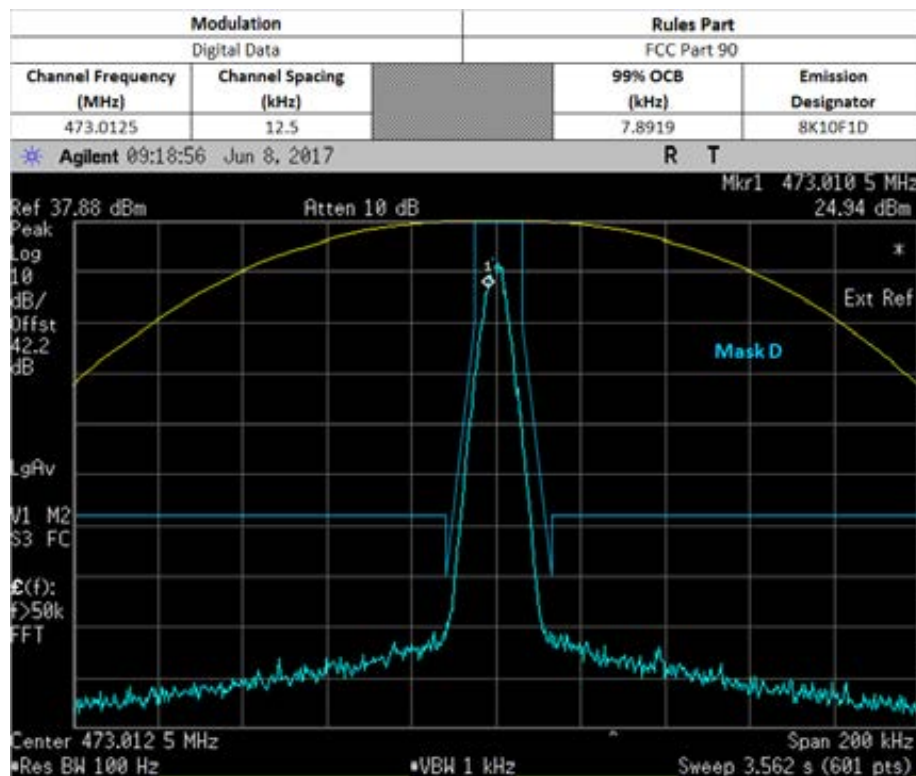
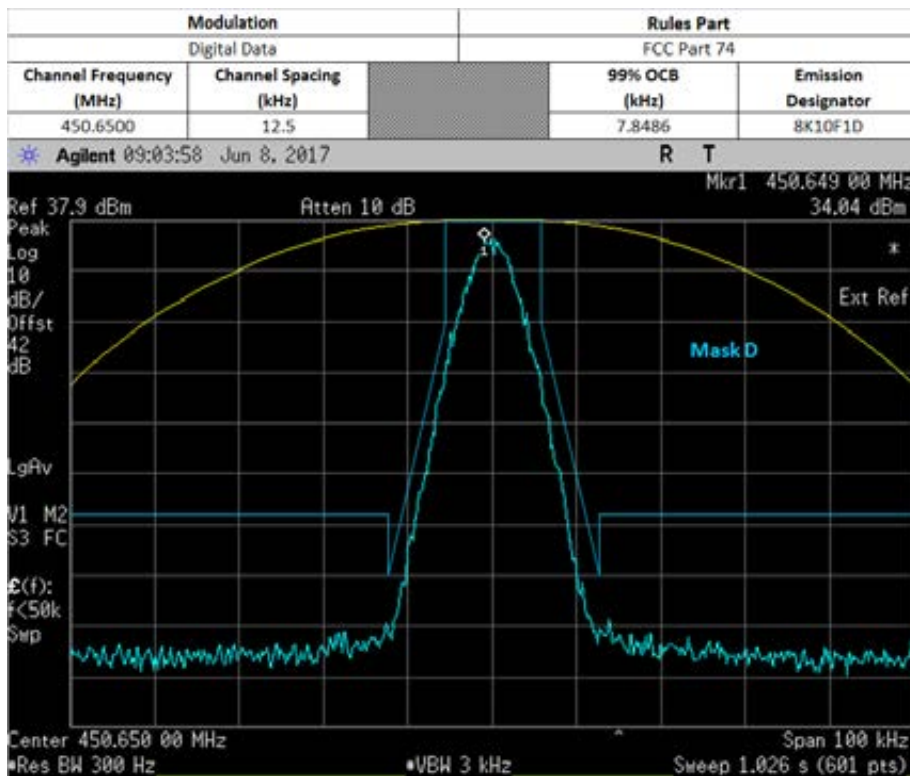

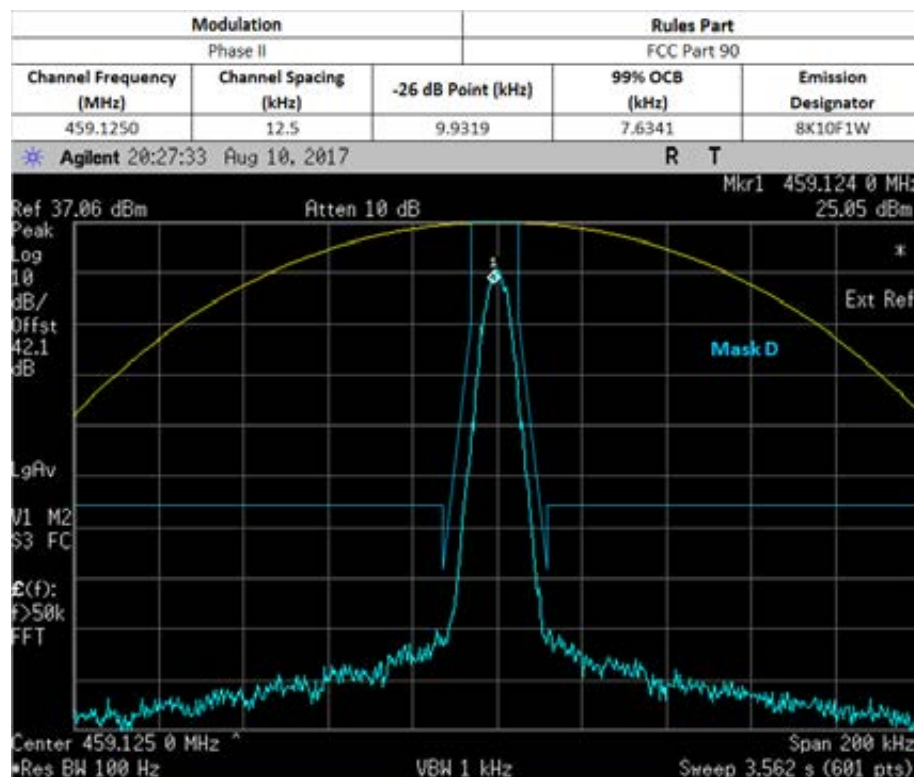
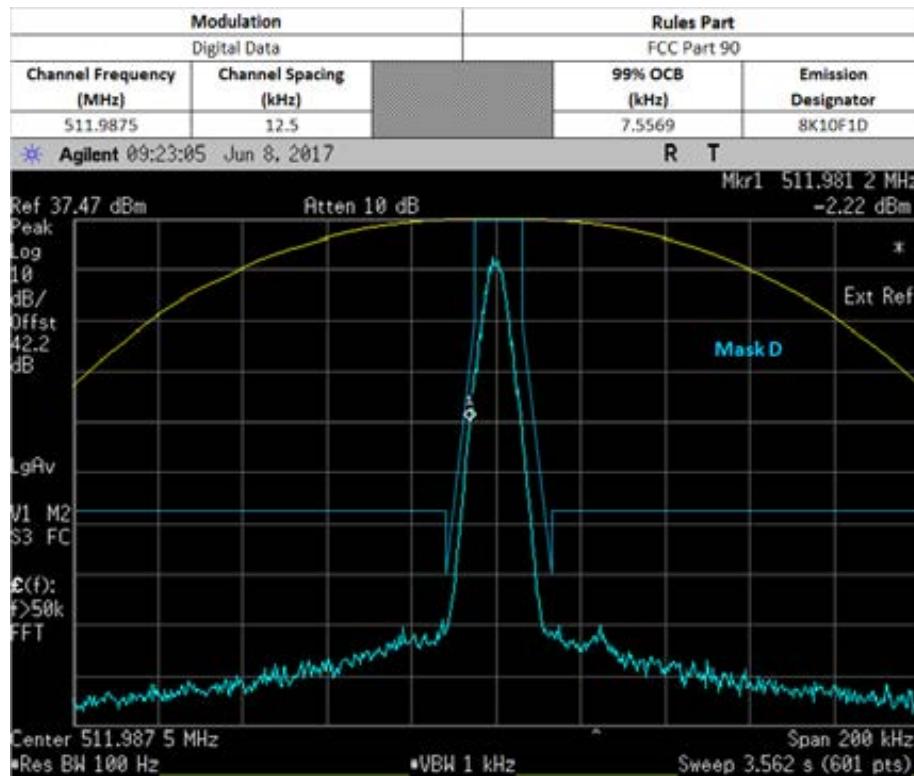

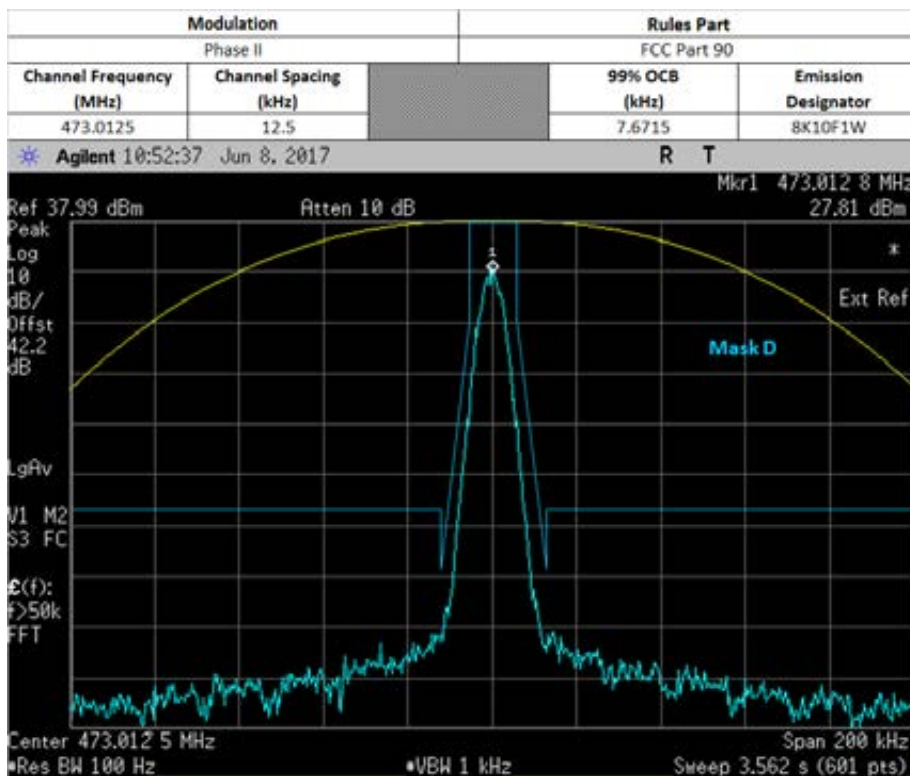
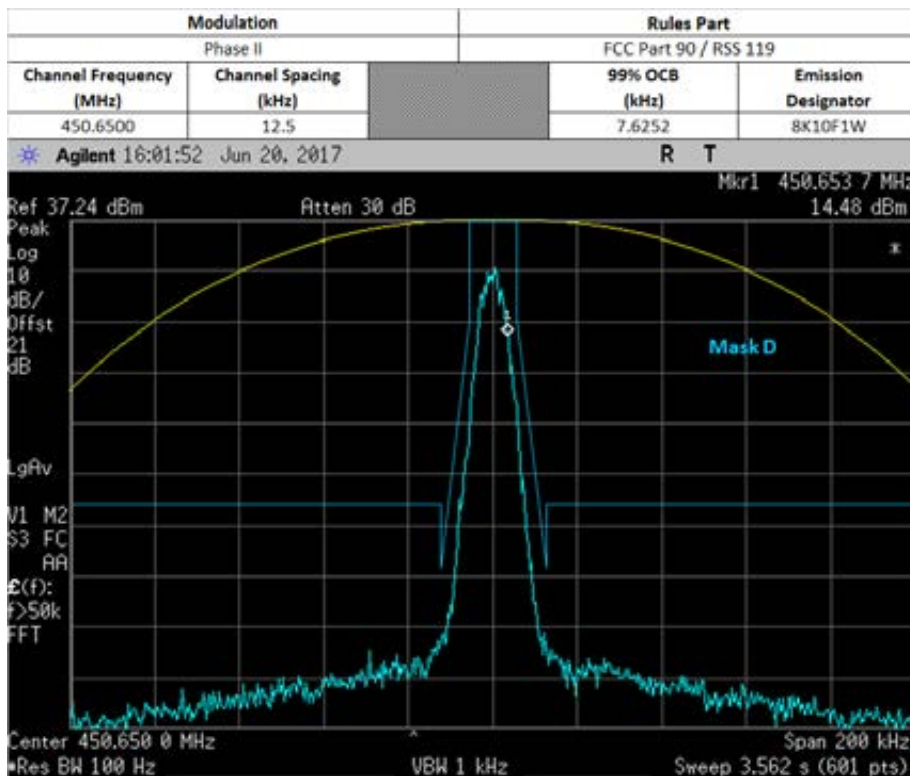

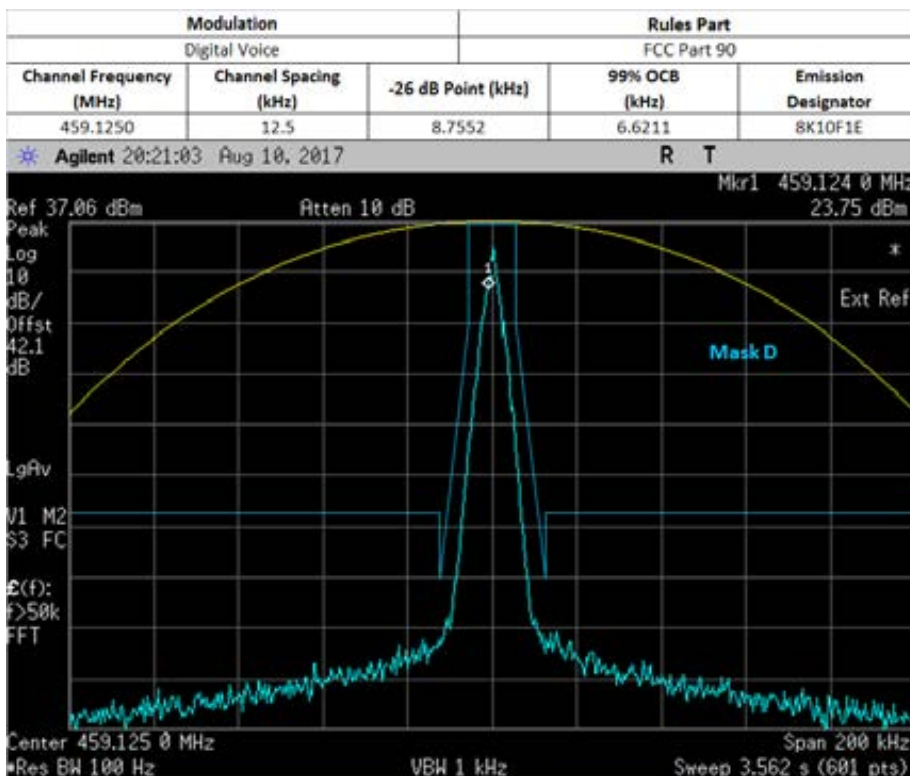
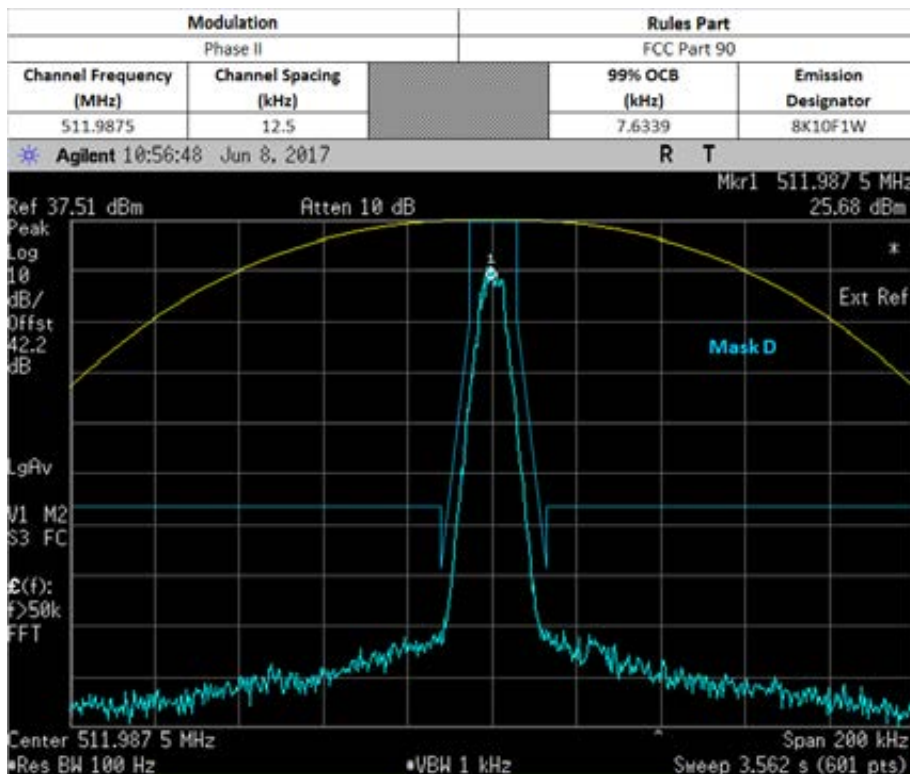

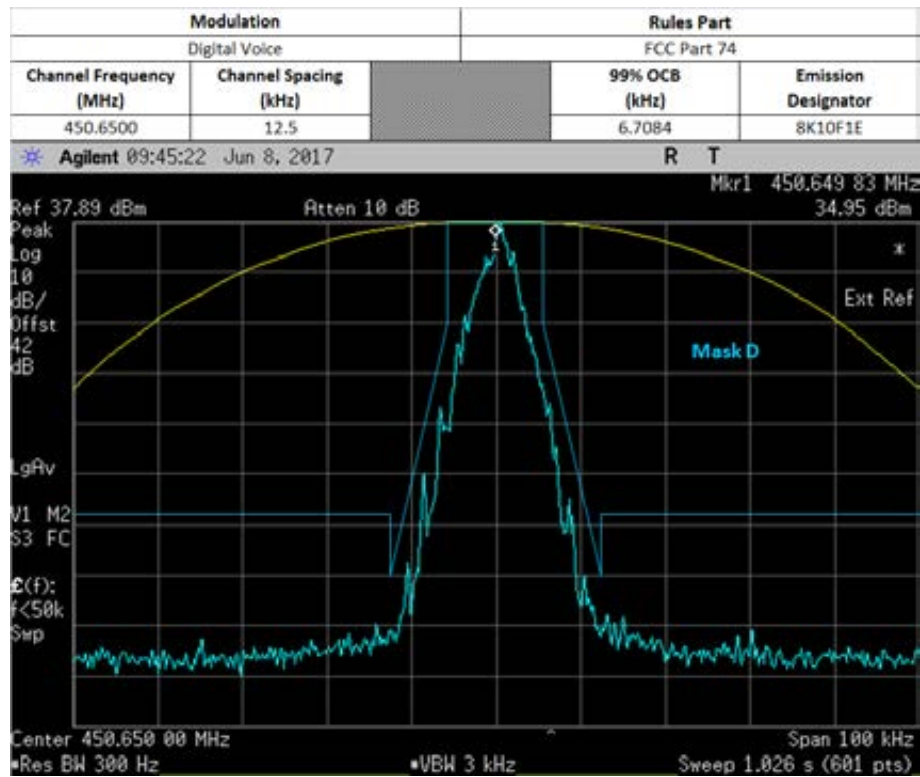
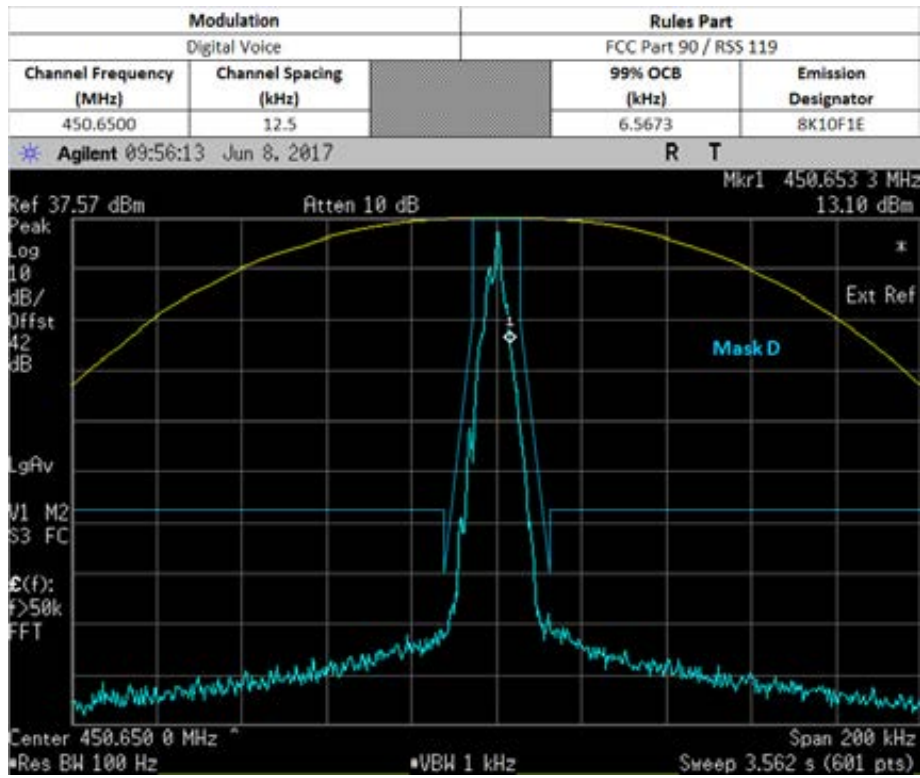

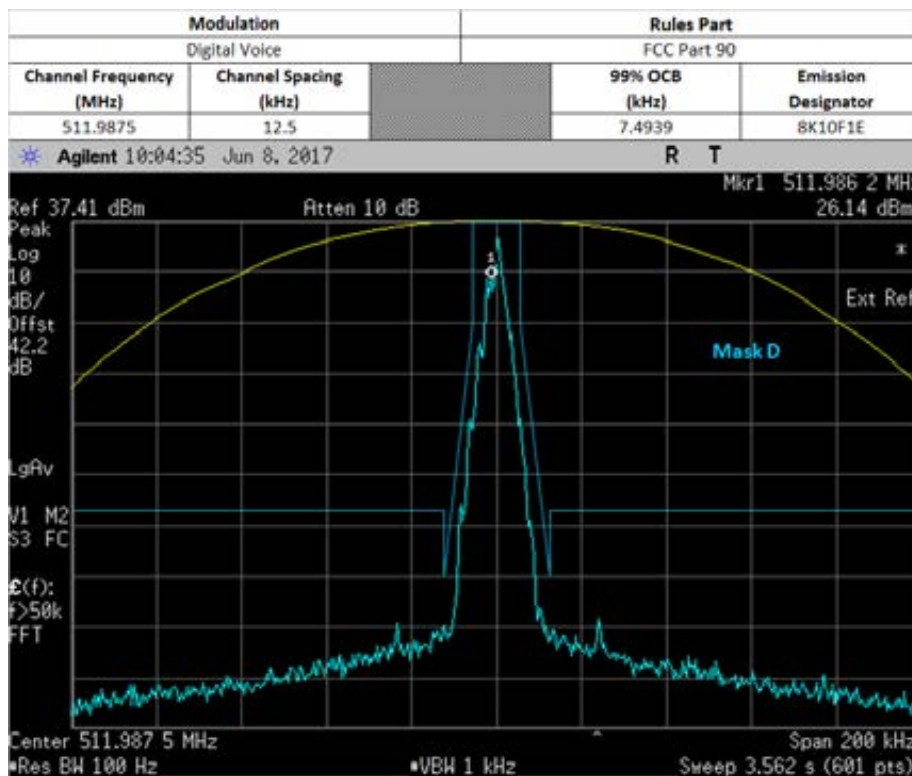
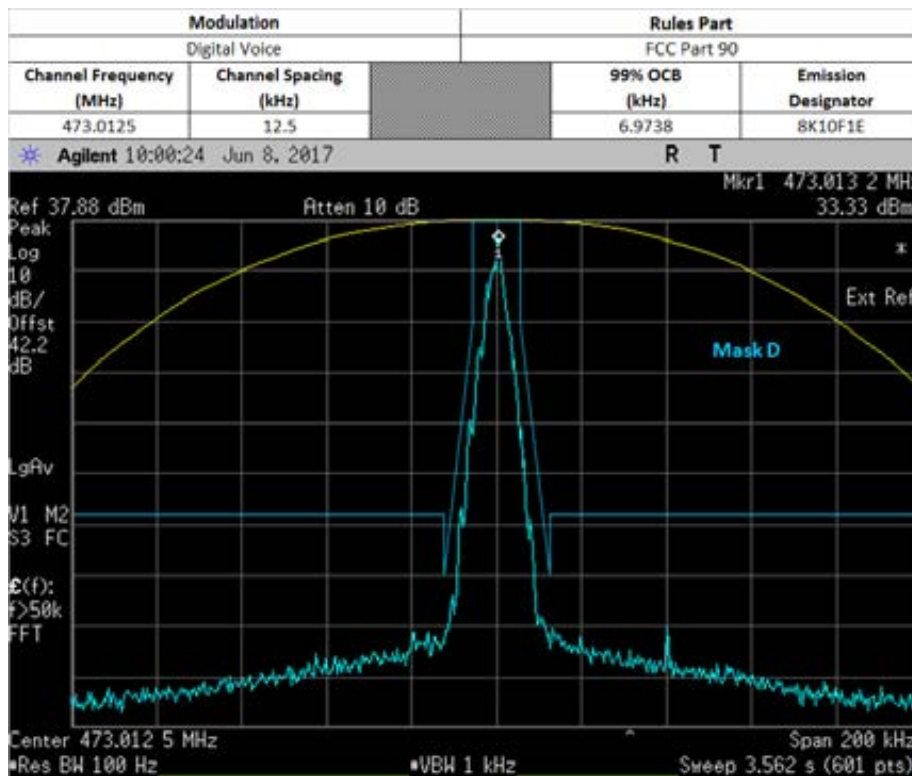

6.6.5. Test Limit

The 99% occupied bandwidth is the width of a frequency band such that, below the lower and above the upper frequency limits, the mean powers emitted are each equal to a specified percentage 0.5% of the total mean transmitted power.

6.7. Band Edge Conducted Spurious Emission (Part 22)

6.7.1. Test Setup (Analog)

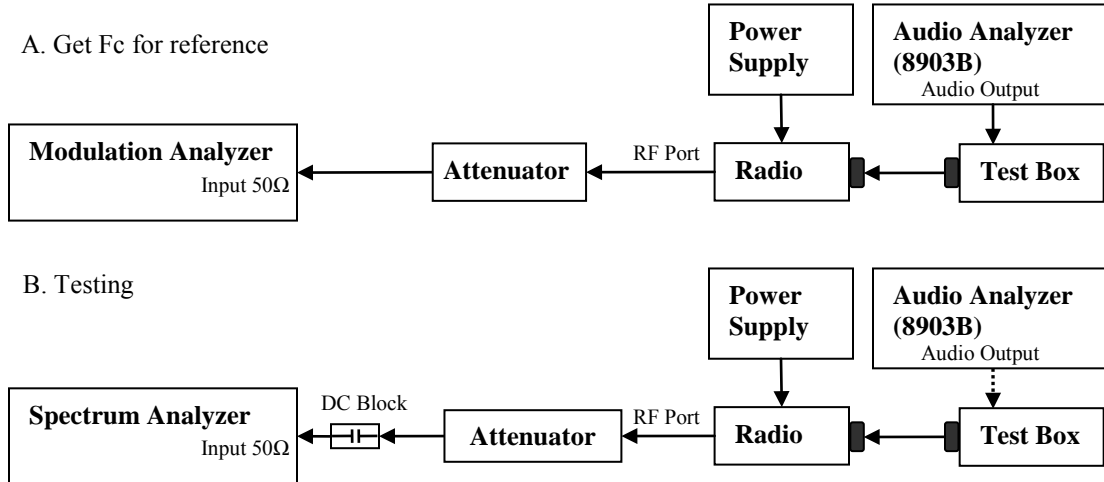

- 1) The DUT transmitter output port was connected to Modulation Analyzer.
- 2) Set the audio bandwidth filter to 15 kHz low pass filter and 50 kHz high pass filter.
- 3) Path loss for the measurement included.
- 4) Select the Occupied Bandwidth measurement for 99% and 26dB Emissions Bandwidth Measurement.
- 5) Key in the Fc and RBW= 100Hz.
- 6) Transmit the DUT and record the occupied Bandwidth frequencies.
- 7) Preset the spectrum analyzer for band edge measurement.
- 8) The band edges of lowest and highest channels were measured.
- 9) The center frequency of spectrum is the band edge frequency, span is 60 kHz and RBW is at least 1% of Emission Bandwidth.
- 10) Save the screen shot as modulated signal.
- 11) Remove the audio tone from audio analyzer to capture unmodulated signal.

6.7.2. Test Result (Analog)

Max Power

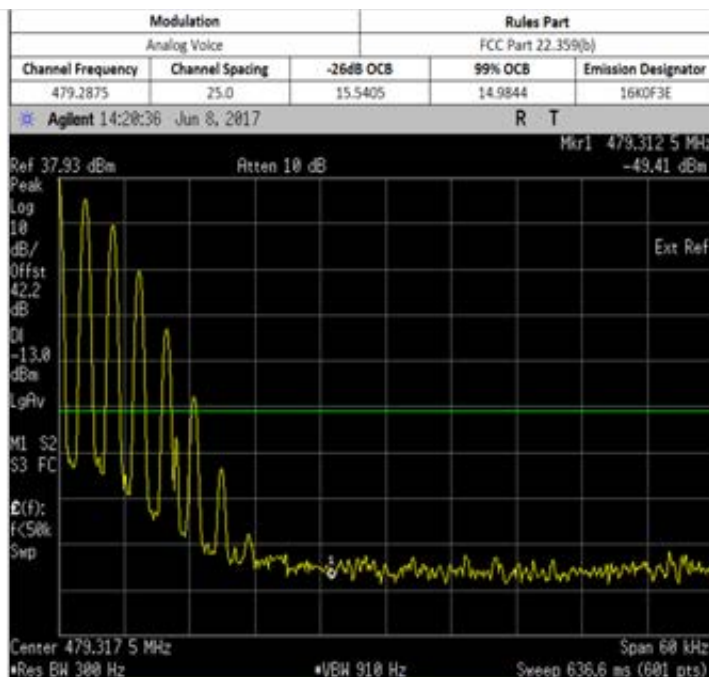
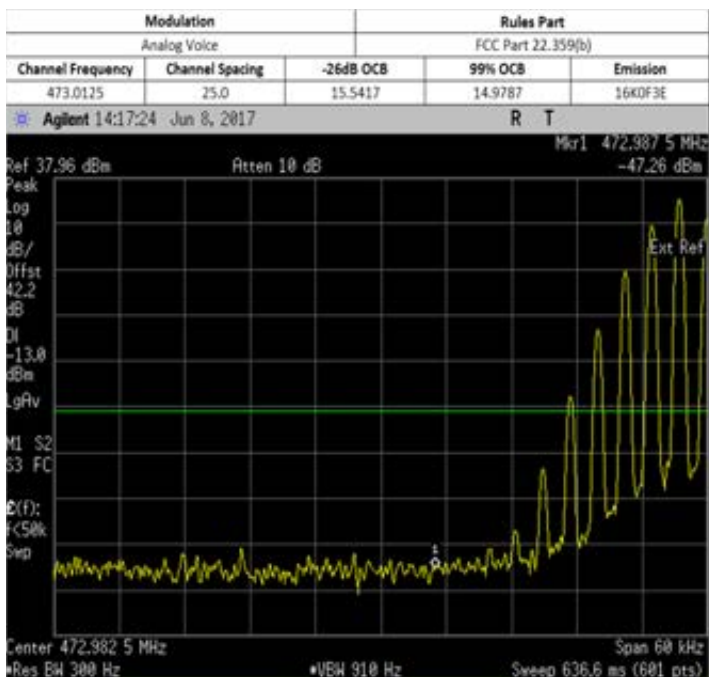
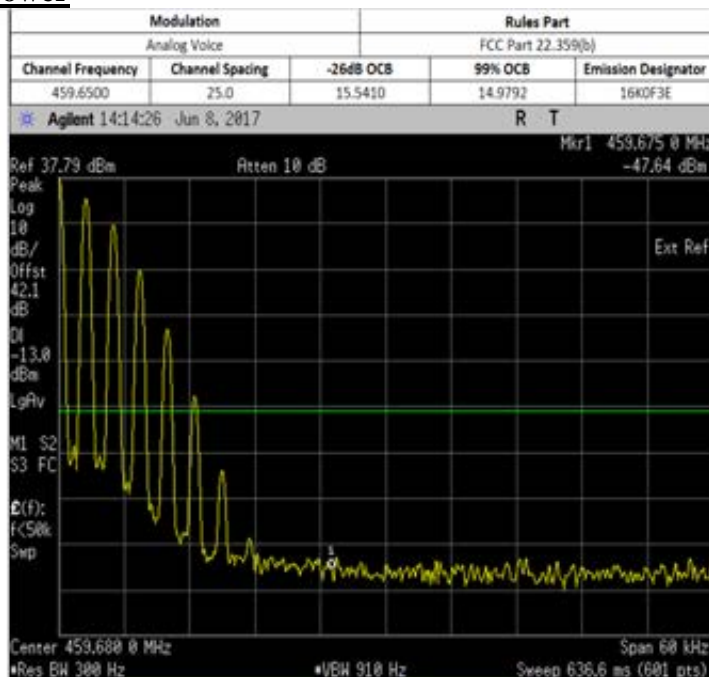
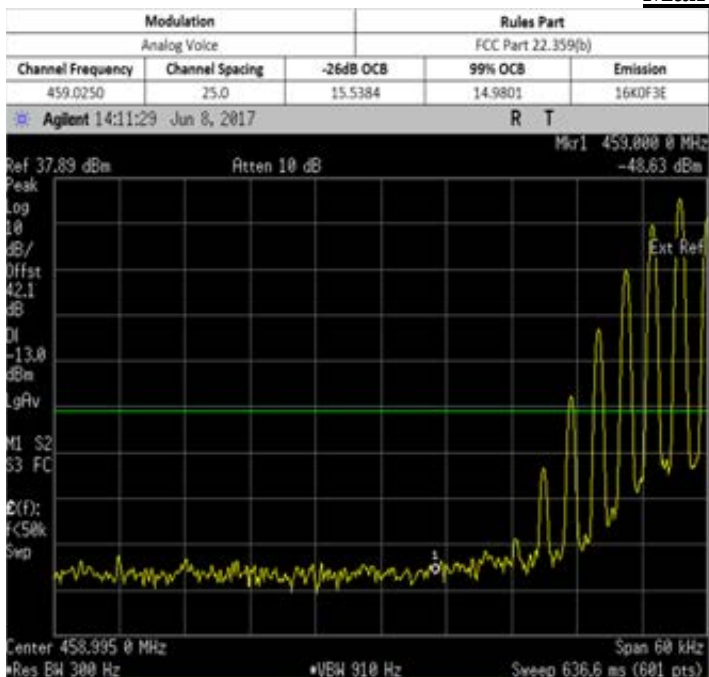

Test Setup (Digital)

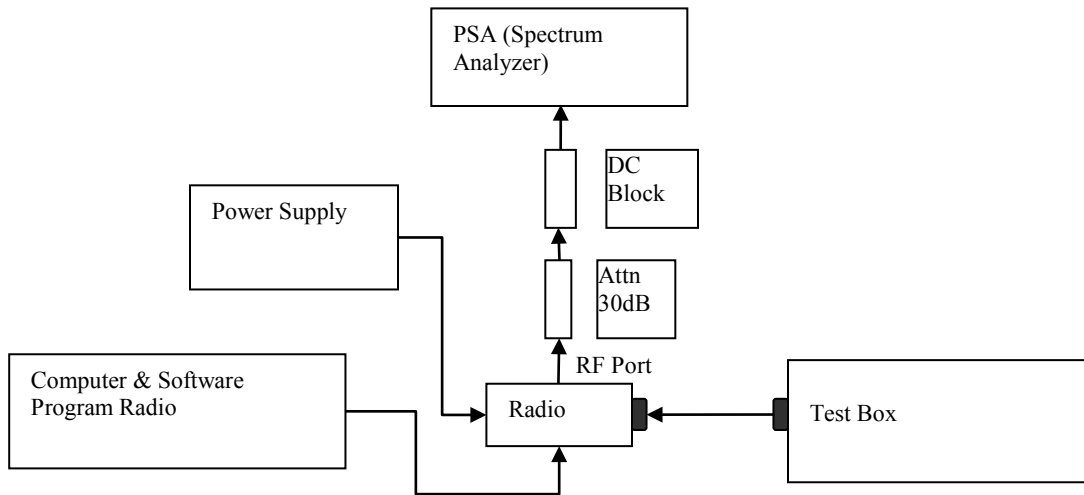

- 1) Program and set radio to operate in desire test frequency and digital mode with modulation. (4FSK**, C4FM or other digital modulation form).
- 2) Path loss for the measurement included.
- 3) Select the Occupied Bandwidth measurement for 99% and 26dB Emissions Bandwidth Measurement.
- 4) Key in the Fc and RBW= 100Hz.
- 5) Transmit radio record the occupied Bandwidth frequencies.
- 6) Preset the spectrum analyzer for band edge measurement.
- 7) The band edges of lowest and highest channels were measured.
- 8) The center frequency of spectrum is the band edge frequency, span is 60 kHz and RBW is at least 1% of Emission Bandwidth.
- 9) Save the screen shot.

**Note:

- For Digital Modulation for 12.5 kHz Voice (F1E) and 12.5 kHz Data (F1D) would be the same. Therefore only measurements with F1E modulation shown below.

6.7.3. Test Result (Digital)

Max Power

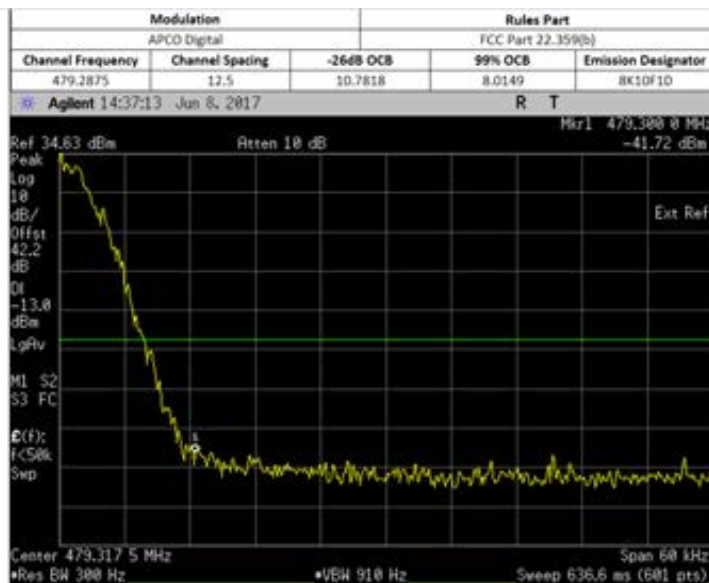
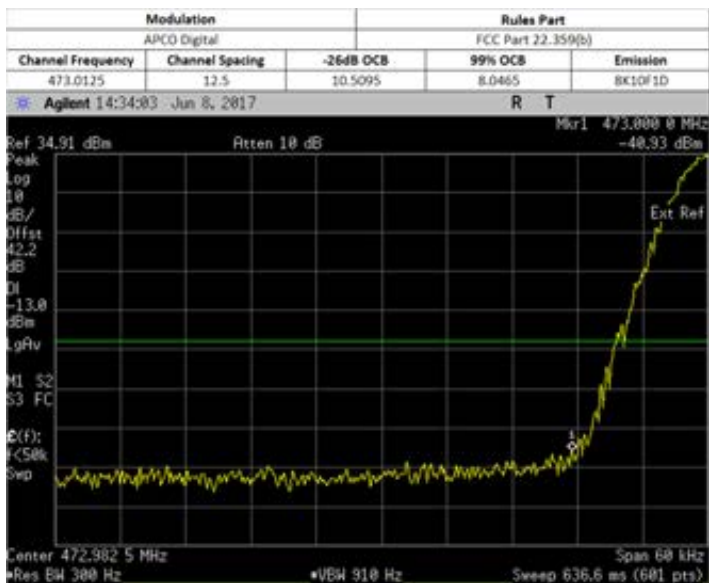
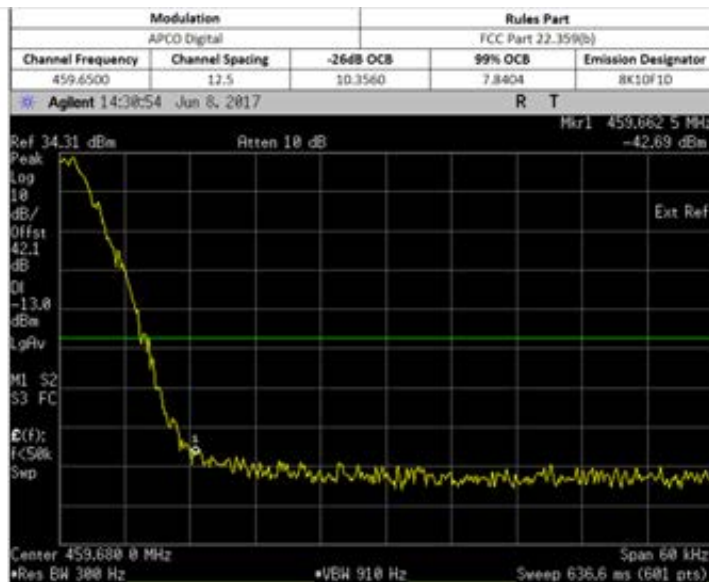
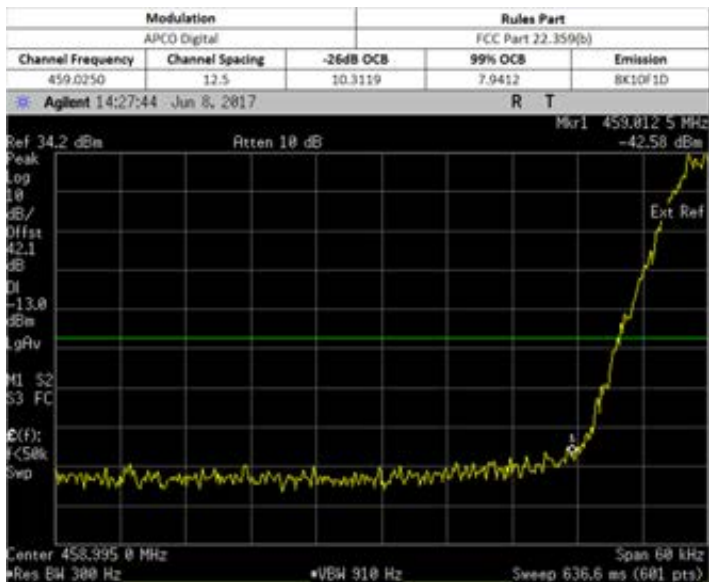

Max Power

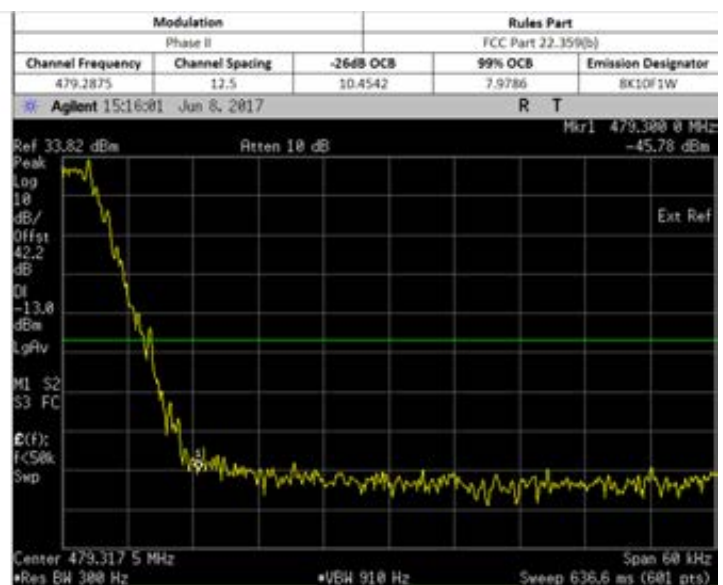
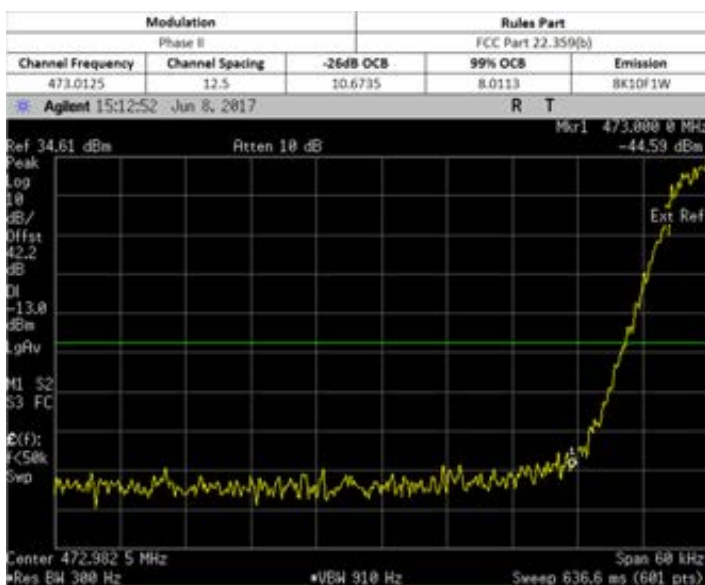
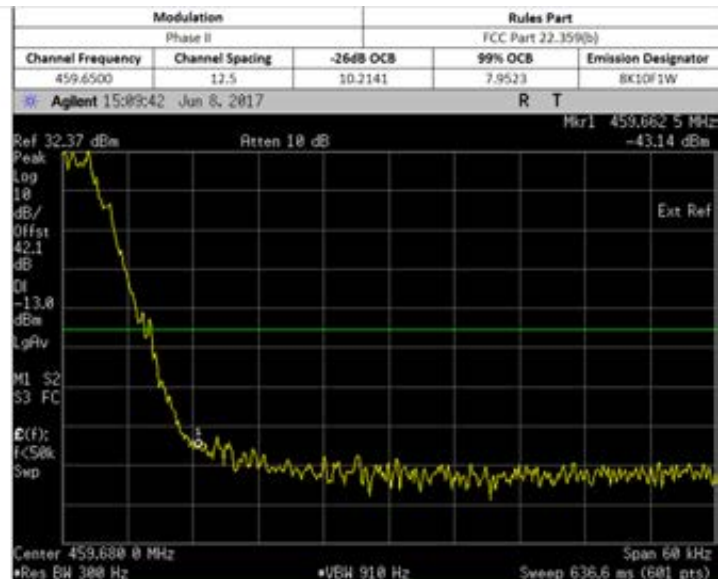
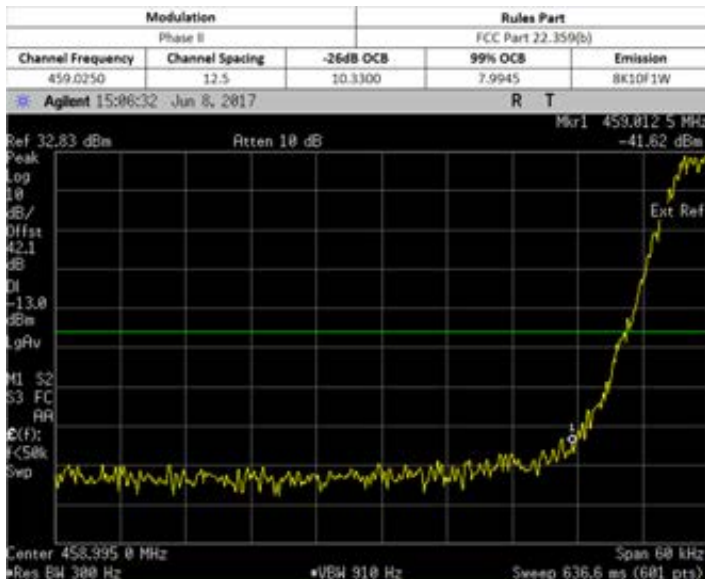

6.7.4. Test Limit

The power of any emission outside of the authorized operating frequency ranges must be attenuated below the transmitting power (P) by a factor of at least $43 + 10 \log(P)$ dB.

6.8. Transient Frequency Behavior

6.8.1. Test Setup

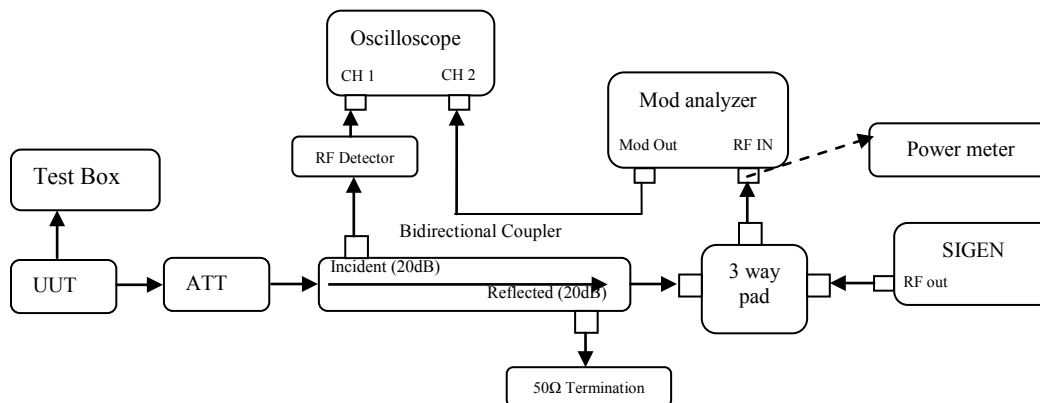

- 1) Connect the setup as figure above.
- 2) Path loss for the measurement included.
- 3) Set on Sigen with the assigned center frequency, internal 1 kHz FM tone.
FM Deviation: Analog 25kHz Channel Spacing = 25 kHz
Analog 12.5 kHz Channel Spacing = 12.5 kHz
C4FM = 12.5 kHz
- 4) Turn on 50 kHz high pass filter and 15 kHz low pass filter on modulation analyzer.
- 5) Supply sufficient attenuation ATT to provide the output power of $\leq -11\text{dBm}$ into power meter when UUT is keying up.
- 6) Note the power level on power meter and dekey the UUT.
- 7) Adjust the amplitude of the signal generator to the level power meter, maintained the amplitude throughout the rest of the measurement.
- 8) Connect the output to modulation analyzer.
- 9) Set the horizontal sweep rate on the storage oscilloscope to 10 milliseconds per division and adjust the display to continuously view the 1000 Hz. Adjust the vertical amplitude control of the oscilloscope to display the 1000 Hz at $\square 4$ divisions vertically centered on the display.
- 10) Reduce 30dB attenuation and transmit the radio to get the trigger line.
- 11) Capture the screen shot for key-up (rising edge) and de-key (falling edge) mode.

6.8.2. Test Result

Analog: 467.7750 MHz, 25.0 kHz Channel Spacing, Max Power (NOT FOR FCC REVIEW)
Key-up (Rising Edge)

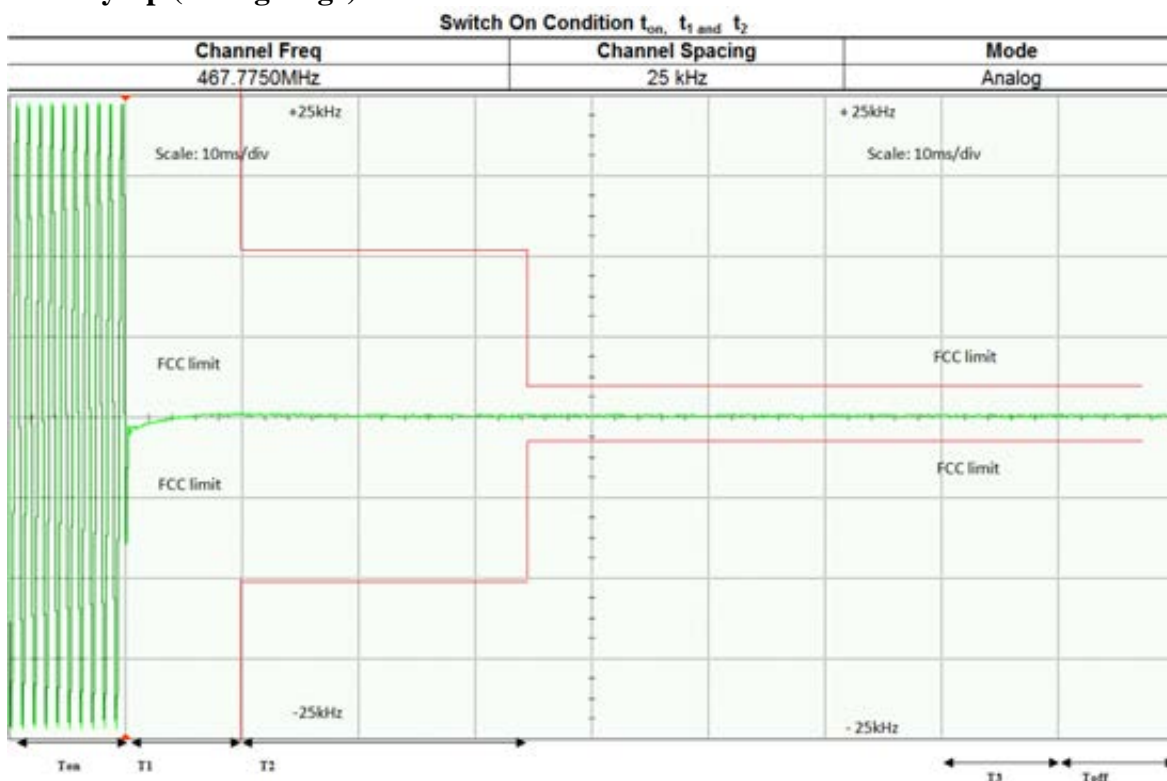

De-key (Falling Edge)

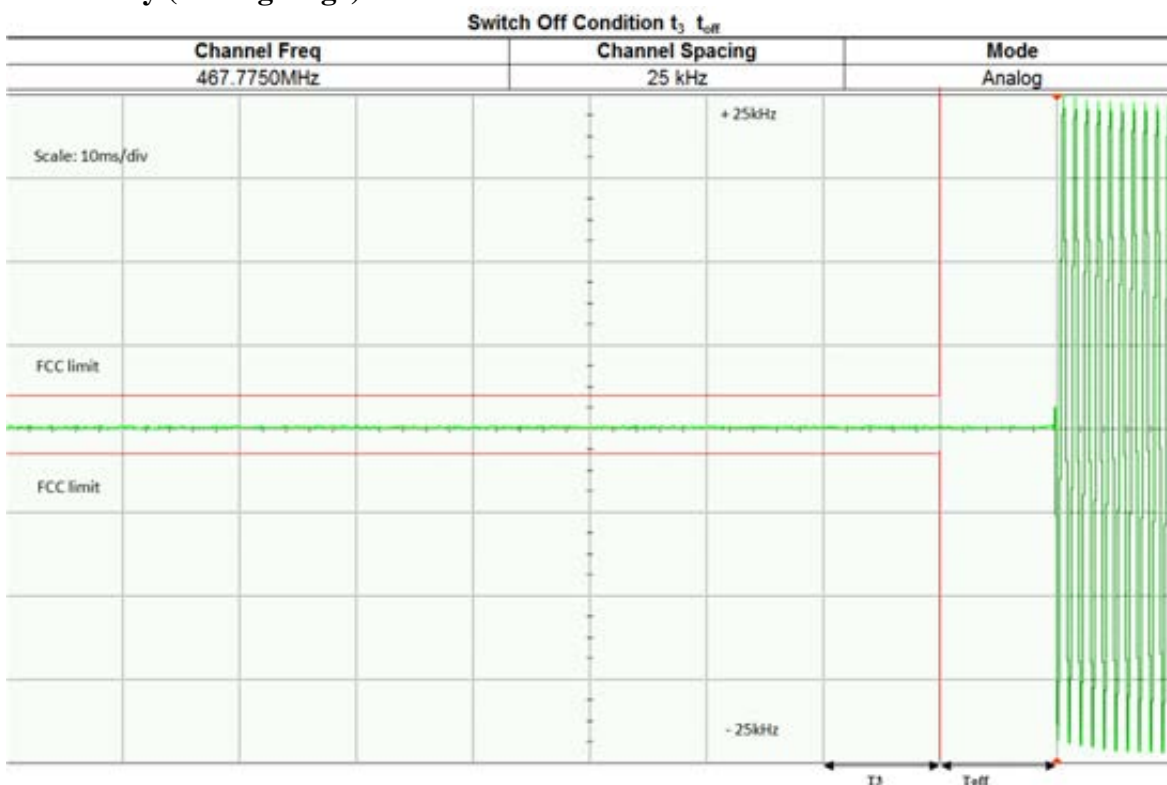

**APCO Digital: 467.7750 MHz, 12.5 kHz Channel Spacing, Max Power
 Key-up (Rising Edge)**

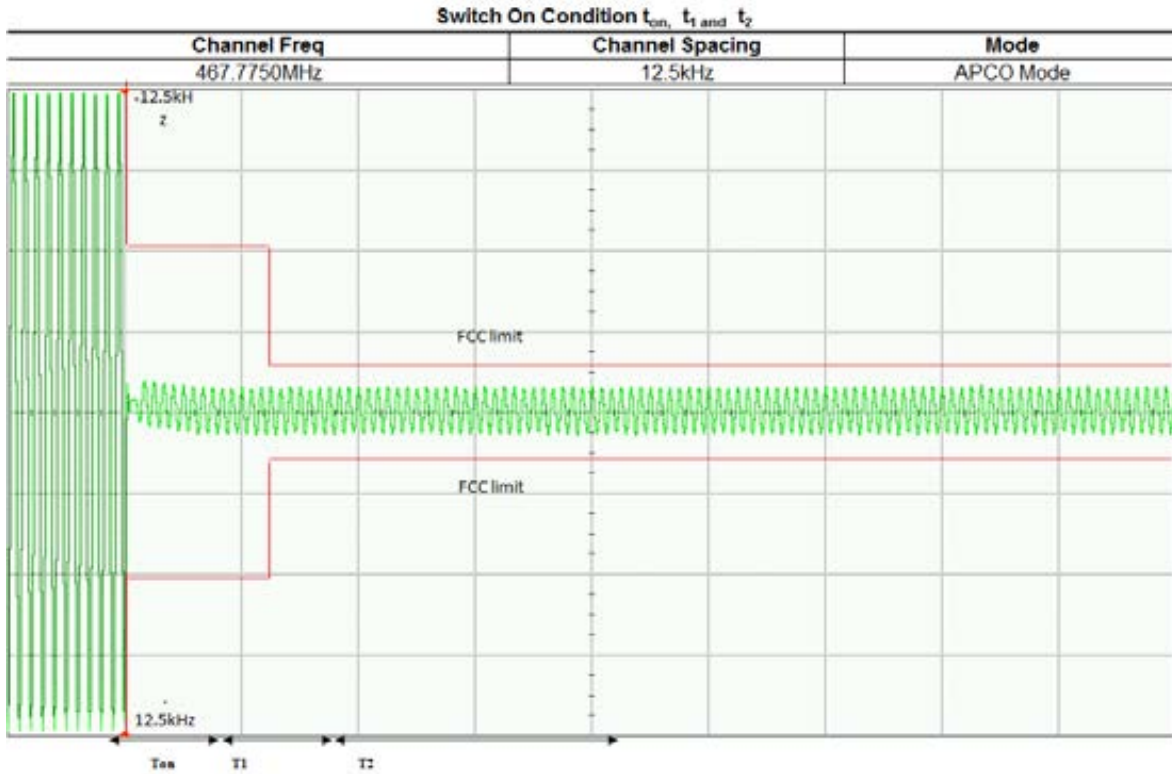

De-key (Falling Edge)

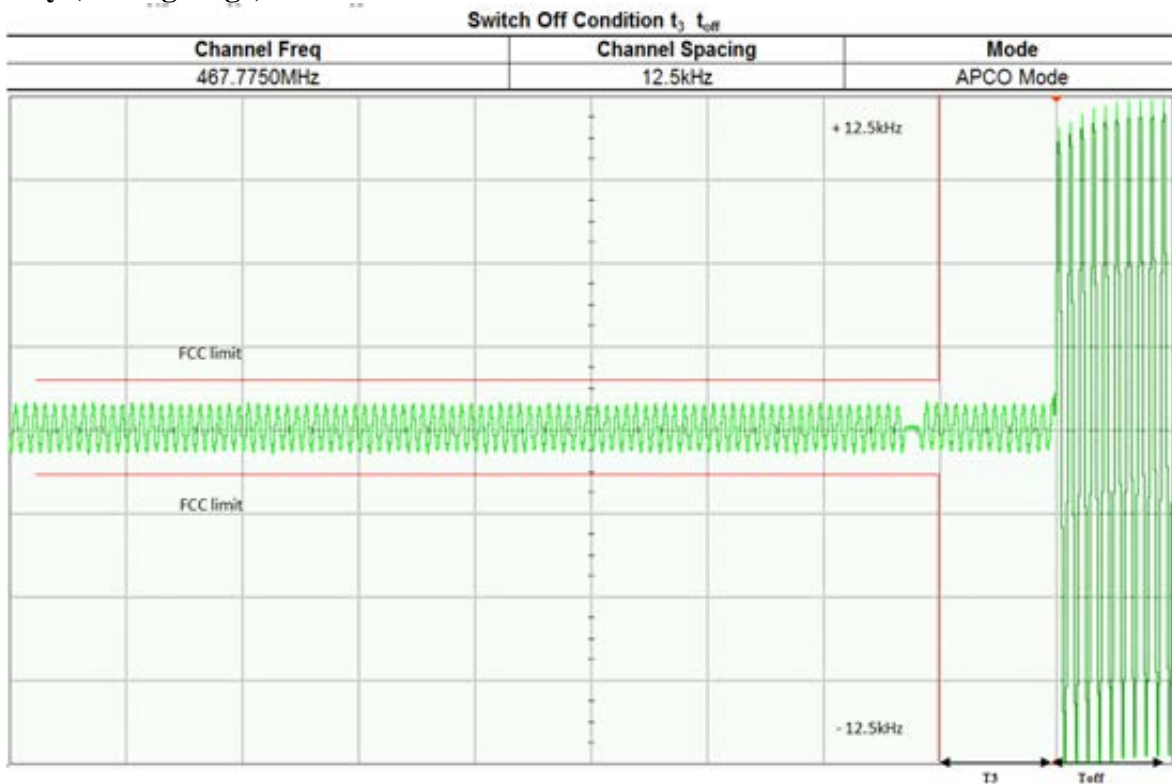

6.8.3. Test Limit

Transmitters designed to operate in the 150-174 MHz and 421-512 MHz frequency bands must maintain transient frequencies within the maximum frequency difference limits during the time intervals indicated:

Time intervals ^{1 2}	Maximum frequency difference ³	All equipment	
		150 to 174 MHz	421 to 512 MHz
Transient Frequency Behavior for Equipment Designed to Operate on 25 kHz Channels			
t_1^4	±25.0 kHz	5.0 ms	10.0 ms
t_2	±12.5 kHz	20.0 ms	25.0 ms
t_3^4	±25.0 kHz	5.0 ms	10.0 ms
Transient Frequency Behavior for Equipment Designed to Operate on 12.5 kHz Channels			
t_1^4	±12.5 kHz	5.0 ms	10.0 ms
t_2	±6.25 kHz	20.0 ms	25.0 ms
t_3^4	±12.5 kHz	5.0 ms	10.0 ms
Transient Frequency Behavior for Equipment Designed to Operate on 6.25 kHz Channels			
t_1^4	±6.25 kHz	5.0 ms	10.0 ms
t_2	±3.125 kHz	20.0 ms	25.0 ms
t_3^4	±6.25 kHz	5.0 ms	10.0 ms

¹_{on} is the instant when a 1 kHz test signal is completely suppressed, including any capture time due to phasing.

t_1 is the time period immediately following t_{on} .

t_2 is the time period immediately following t_1 .

t_3 is the time period from the instant when the transmitter is turned off until t_{off} .

t_{off} is the instant when the 1 kHz test signal starts to rise.

² During the time from the end of t_2 to the beginning of t_3 , the frequency difference must not exceed the limits specified in §90.213.

³ Difference between the actual transmitter frequency and the assigned transmitter frequency.

⁴ If the transmitter carrier output power rating is 6 watts or less, the frequency difference during this time period may exceed the maximum frequency difference for this time period.

6.9. Adjacent Channel Power

6.9.1. Test Setup (Analog)

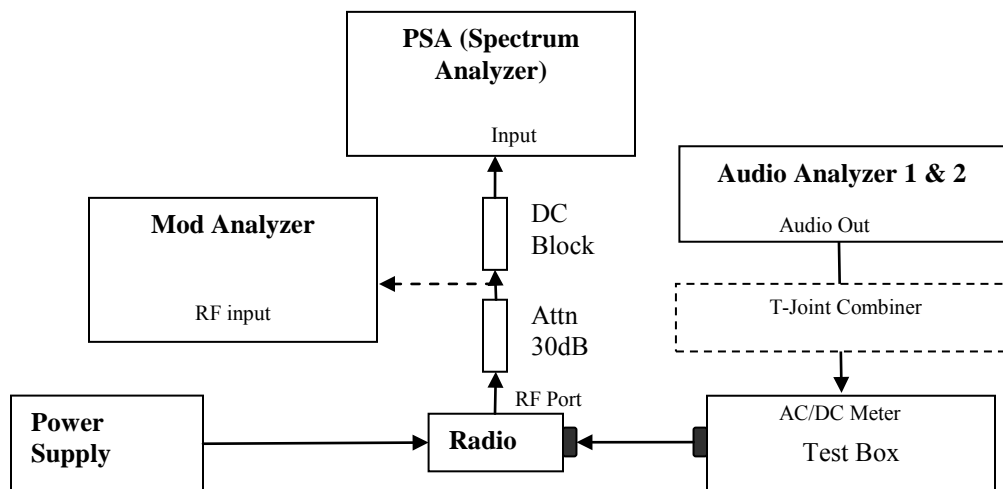

- 1) The DUT transmitter output port was connected to modulation analyzer.
- 2) Path loss for the measurement included.
- 3) Transmit the radio and turn on 1st audio analyzer with audio frequency 650Hz, 50% rated deviation, and record the amplitude value as AmpT1.
- 4) Turn off Audio analyzer 1 and turn on audio analyzer 2, set the audio frequency to 2.2 kHz and 50% deviation. Record the amplitude as AmpT2.
- 5) Turn both audio analyzers ON and up 10dB amplitude level.
- 6) Connect the output to PSA and set to assigned center frequency.
- 7) Set Span, RBW and VBW as shown in FCC rules part 90.543.
- 8) Transmit the radio and record the ACP value in dBc.

Test Result
Not Applicable

6.9.2. Test Setup (Digital)

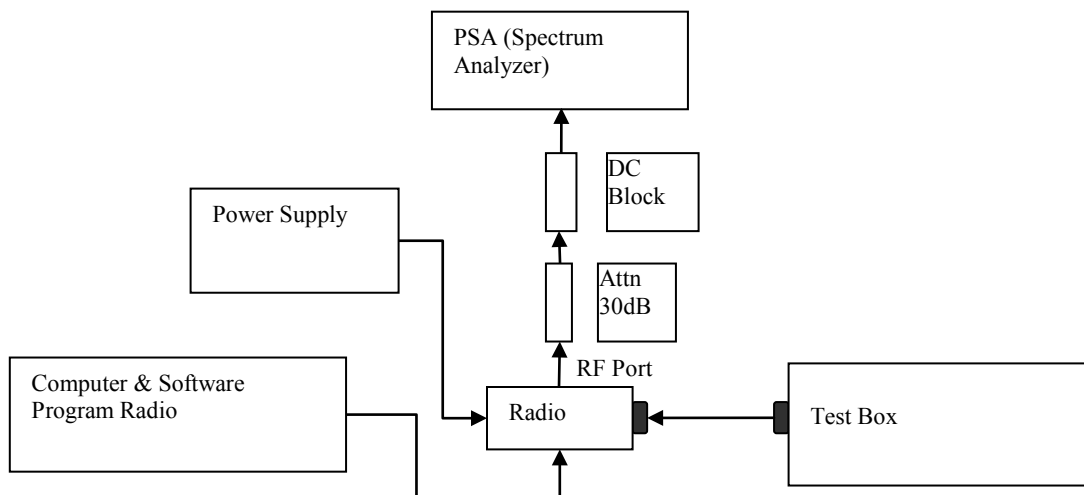

- 1) Program and set radio to operate in desire test frequency and digital mode with modulation. (4FSK, C4FM, CQPSK or other digital modulation form).
- 2) Path loss for the measurement included.
- 3) Prepare setup as per picture.
- 4) Turn on the ACP Measurement – Press Measure, ACP.
- 5) Set Span, RBW and VBW as shown in FCC rules part 90.543.
- 6) Transmit the radio and record the ACP value in dBc.

6.9.3. Test Result
Not Applicable

6.9.4. Test Limit

12.5 kHz MOBILE TRANSMITTER ACP REQUIREMENTS

Offset from center frequency (kHz)	Measurement bandwidth (kHz)	Maximum ACP relative (dBc)
9.375	6.25	-40
15.625	6.25	-60
21.875	6.25	-60
37.50	25.00	-60
62.50	25.00	-65
87.50	25.00	-65
150.00	100	-65
250.00	100	-65
350.00	100	-65
>400 to 12 MHz	30 (s)	-75
12 MHz to paired receive band	30 (s)	-75
In the paired receive band	30 (s)	-100

25 kHz MOBILE TRANSMITTER ACP REQUIREMENTS

Offset from center frequency (kHz)	Measurement bandwidth (kHz)	Maximum ACP relative (dBc)
15.625	6.25	-40
21.875	6.25	-60
37.50	25	-60
62.50	25	-65
87.50	25	-65
150.00	100	-65
250.00	100	-65
350.00	100	-65
>400 kHz to 12 MHz	30 (s)	-75
12 MHz to paired receive band	30 (s)	-75
In the paired receive band	30 (s)	-100

12.5 kHz BASE TRANSMITTER ACP REQUIREMENTS

Offset from center frequency (kHz)	Measurement bandwidth (kHz)	Maximum ACP (dBc)
9.375	6.25	-40
15.625	6.25	-60
21.875	6.25	-60
37.5	25	-60
62.5	25	-65
87.5	25	-65
150	100	-65
250	100	-65
350.00	100	-65
>400 kHz to 12 MHz	30 (s)	-80
12 MHz to paired receive band	30 (s)	-80
In the paired receive band	30 (s)	¹ -85

25 kHz BASE TRANSMITTER ACP REQUIREMENTS

Offset from center frequency (kHz)	Measurement bandwidth (kHz)	Maximum ACP (dBc)
15.625	6.25	-40
21.875	6.25	-60
37.5	25	-60
62.5	25	-65
87.5	25	-65
150	100	-65
250	100	-65
350	100.00	-65
>400 kHz to 12 MHz	30 (s)	-80
12 MHz to paired receive band	30 (s)	-80
In the paired receive band	30 (s)	¹ -85

6.10. Conducted Spurious Emission

6.10.1. Test Setup

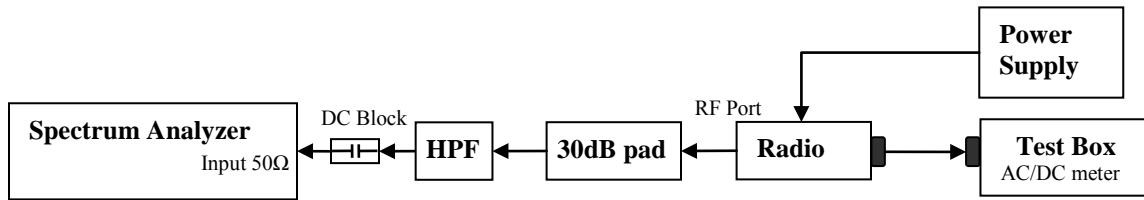

- 1) The DUT transmitter output port was connected to Spectrum Analyzer with above setup.
- 2) Program and set radio to operate in desire test frequency and mode. (Analog / digital modulation form).
- 3) Adjust the PSA RBW = 100kHz for spur emission below 1GHz, and 1MHz for spur emission above 1GHz.
- 4) Set the Ref offset from the pathloss offset calibration file.
- 5) Adjust the center frequency of the spectrum analyzer for incremental coverage of the range from:
 - (a) The lowest radio frequency to $F_c - \text{Test BW}$
 - (b) $F_c + \text{Test BW}$ to $\text{Freq} < 2F_c$.
- 6) Record the levels of spurious emissions and dekey the UUT.
- 7) Turn On HPF path and Key up the UUT.
- 8) Adjust the PSA Freq for incremental coverage of range from $2F_c$ to $10F_c$.
- 9) The levels recorded are the absolute levels of conducted spurious emissions in dBm.

6.10.2. Test Result (Analog)

Analog: 450.6500 MHz, 25.0 kHz Channel Spacing, Max Power Part 74 and RSS 119

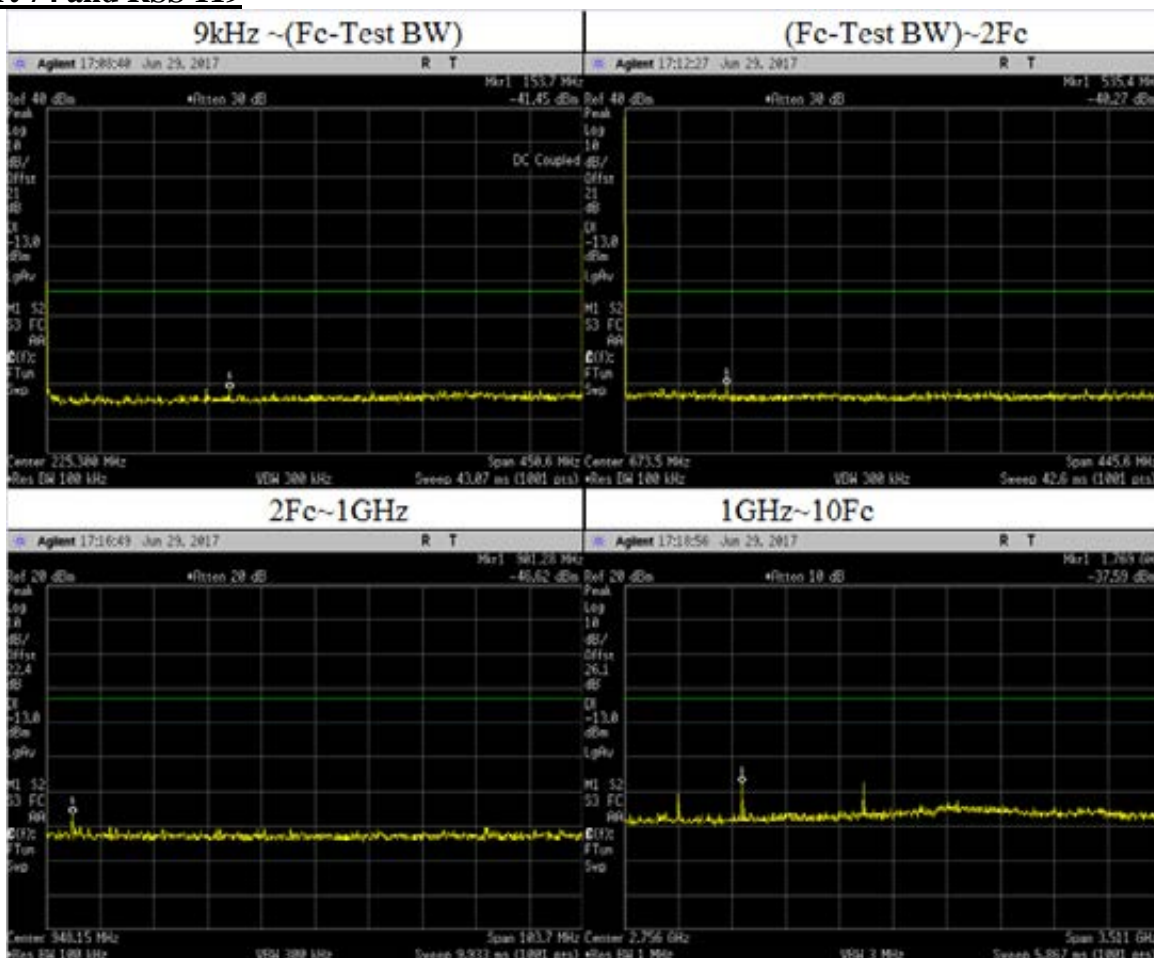

Frequency Range	Highest Spur Freq (MHz)	Spurious Level (dBm)	Failing Limit (dBm)	Remark
9kHz ~ (Fc-Test BW)	153.6546	-41.45	-13	Pass
(Fc-Test BW)~2Fc	535.3640	-40.27	-13	Pass
2Fc~1GHz	901.2800	-46.62	-13	Pass
1GHz~10Fc	1765.8980	-39.67	-13	Pass
	1769.4090	-37.59		
	2562.8950	-37.42		
	1351.9500	-40.77		
	1802.6000	-47.82		
	2253.2500	-47.93		
	2703.9000	-46.97		
	3154.5500	-44.41		
3605.2000	-45.75			
4055.8500	-46.16			
4506.5000	-46.08			

**Analog: 450.6500 MHz, 25.0 kHz Channel Spacing, Low Power
 Part 74 and RSS 119**

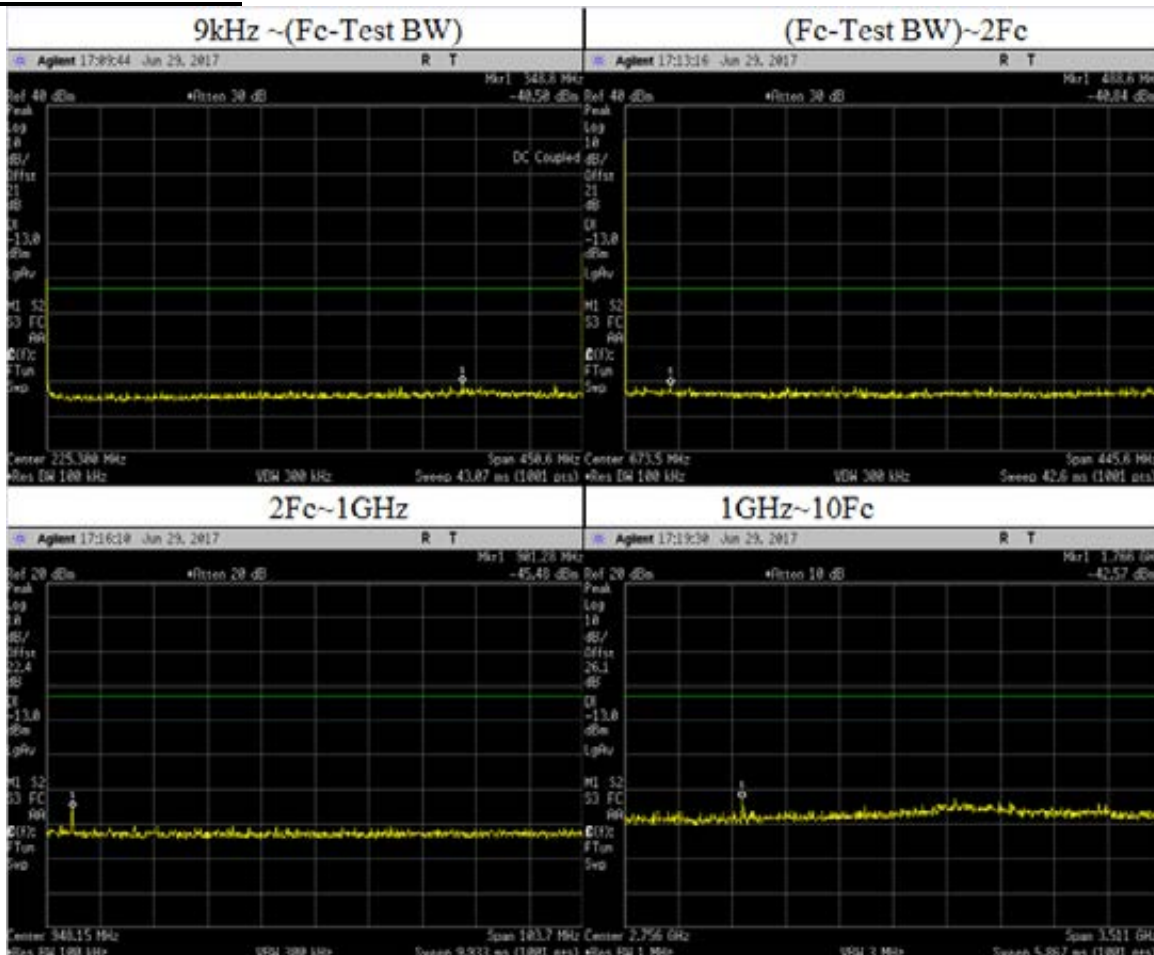

Frequency Range	Highest Spur Freq (MHz)	Spurious Level (dBm)	Failing Limit (dBm)	Remark
9kHz ~ (Fc-Test BW)	348.7644	-40.50	-13	Pass
(Fc-Test BW)~2Fc	488.5760	-40.84	-13	Pass
2Fc~1GHz	901.2800	-45.48	-13	Pass
1GHz~10Fc	1766.0000	-42.57	-13	Pass
	1351.9500	-47.65		
	1802.6000	-48.40		
	2253.2500	-48.41		
	2703.9000	-46.31		
	3154.5500	-44.67		
	3605.2000	-45.94		
	4055.8500	-46.00		
	4506.5000	-45.73		

Analog: 459.0250 MHz, 25.0 kHz Channel Spacing, Max Power
Part 22

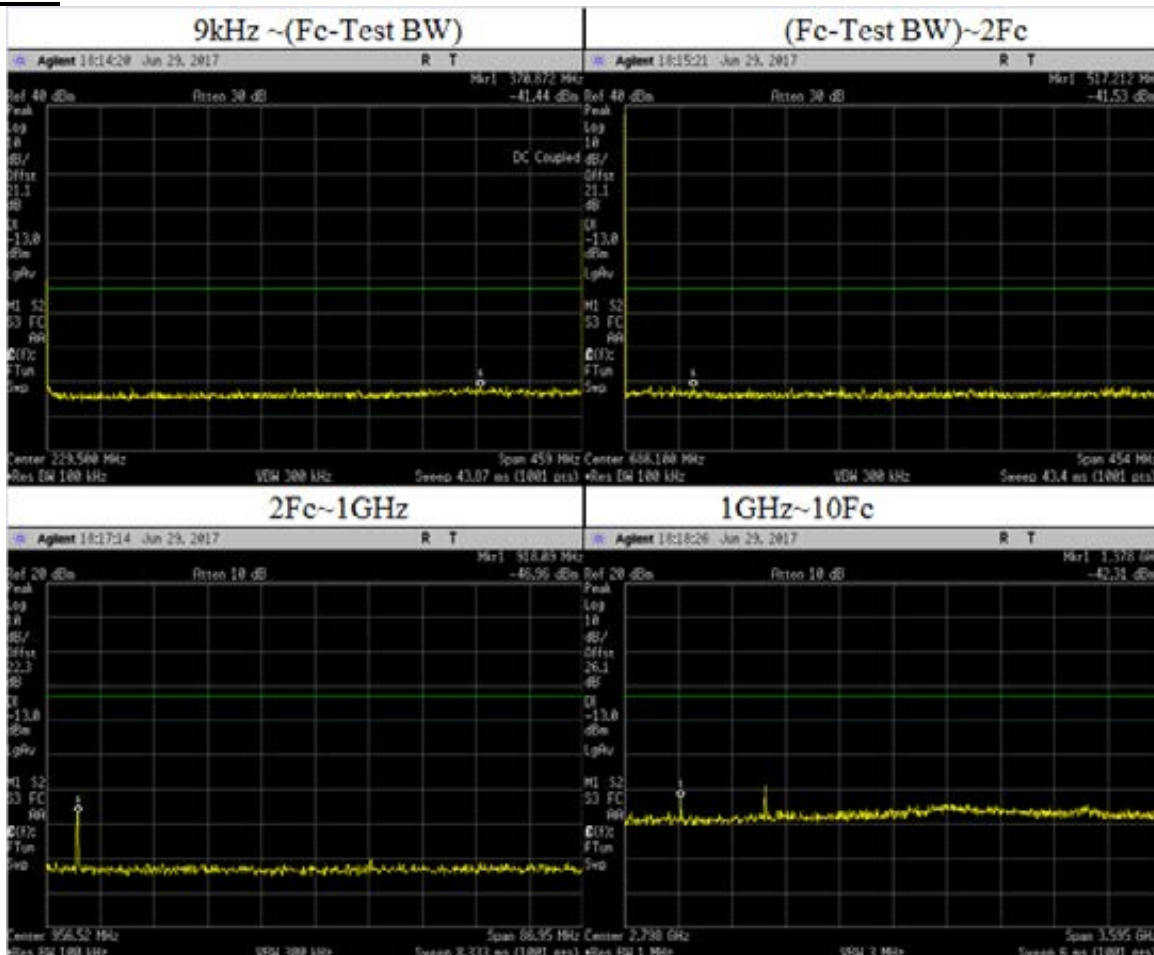

Frequency Range	Highest Spur Freq (MHz)	Spurious Level (dBm)	Failing Limit (dBm)	Remark
9kHz ~ (Fc-Test BW)	370.8720	-41.44	-13	Pass
(Fc-Test BW)~2Fc	517.2120	-41.53	-13	Pass
2Fc~1GHz	918.0900	-46.96	-13	Pass
	918.0500	-46.96		
1GHz~10Fc	1377.9750	-42.31	-13	Pass
	1942.3900	-38.20		
	1377.0750	-42.31		
	1836.1000	-47.40		
	2295.1250	-47.22		
	2754.8600	-46.75		
	3212.1750	-45.02		
	3672.2000	-46.47		
	4131.2250	-47.25		
4590.2500	-48.13			

Analog: 459.6500 MHz, 25.0 kHz Channel Spacing, Max Power
Part 22

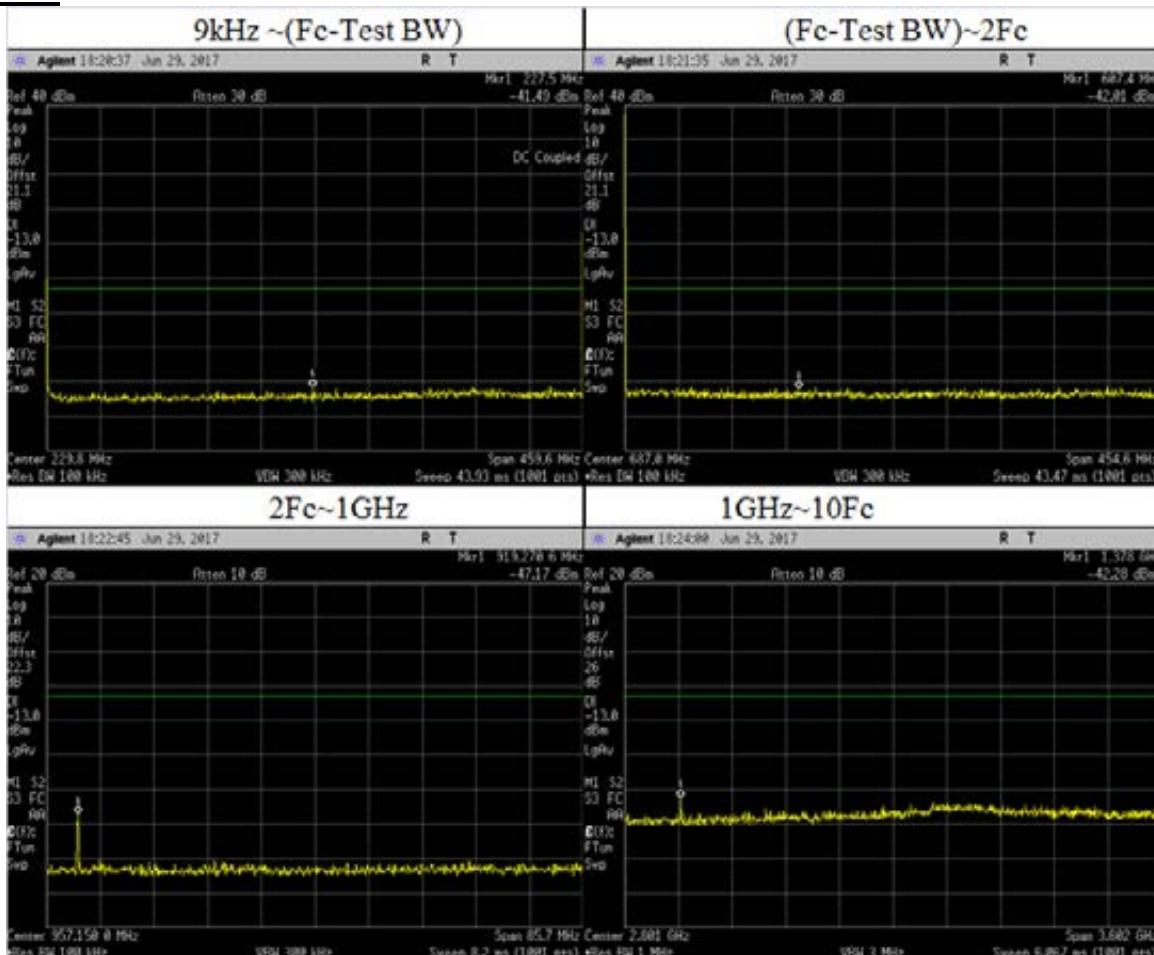

Frequency Range	Highest Spur Freq (MHz)	Spurious Level (dBm)	Failing Limit (dBm)	Remark
9kHz ~ (Fc-Test BW)	227.5000	-41.49	-13	Pass
(Fc-Test BW)~2Fc	607.4000	-42.01	-13	Pass
2Fc~1GHz	919.2700	-47.17	-13	Pass
1GHz~10Fc	1378.0000	-42.28	-13	Pass
	1378.9500	-42.28		
	1838.6000	-47.69		
	2298.2500	-47.85		
	2757.9000	-47.71		
	3217.5500	-44.81		
	4136.8500	-47.14		
	4596.5000	-47.98		

Analog: 473.0125 MHz, 25.0 kHz Channel Spacing, Max Power
Part 22

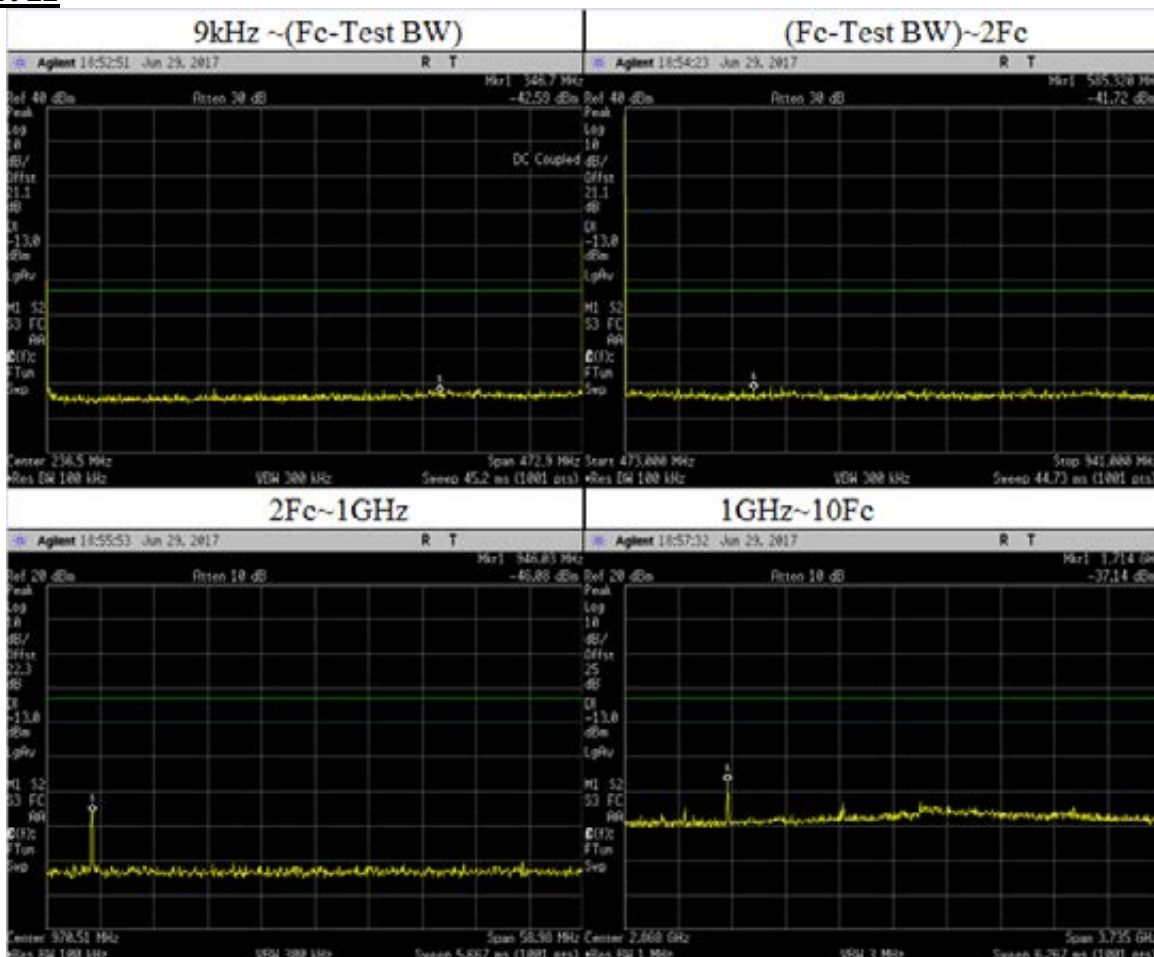

Frequency Range	Highest Spur Freq (MHz)	Spurious Level (dBm)	Failing Limit (dBm)	Remark
9kHz ~ (Fc-Test BW)	346.7000	-42.59	-13	Pass
(Fc-Test BW)~2Fc	565.7200	-41.72	-13	Pass
2Fc~1GHz	946.0300	-46.08	-13	Pass
1GHz~10Fc	1714.0000	-37.14	-13	Pass
	1419.0380	-44.92		
	1892.0500	-48.49		
	2365.0630	-48.22		
	2838.0750	-46.30		
	3311.0880	-46.88		
	3784.1000	-47.04		
4257.1130	-47.32			
4730.1250	-48.16			

Analog: 479.2875 MHz, 25.0 kHz Channel Spacing, Max Power
Part 22

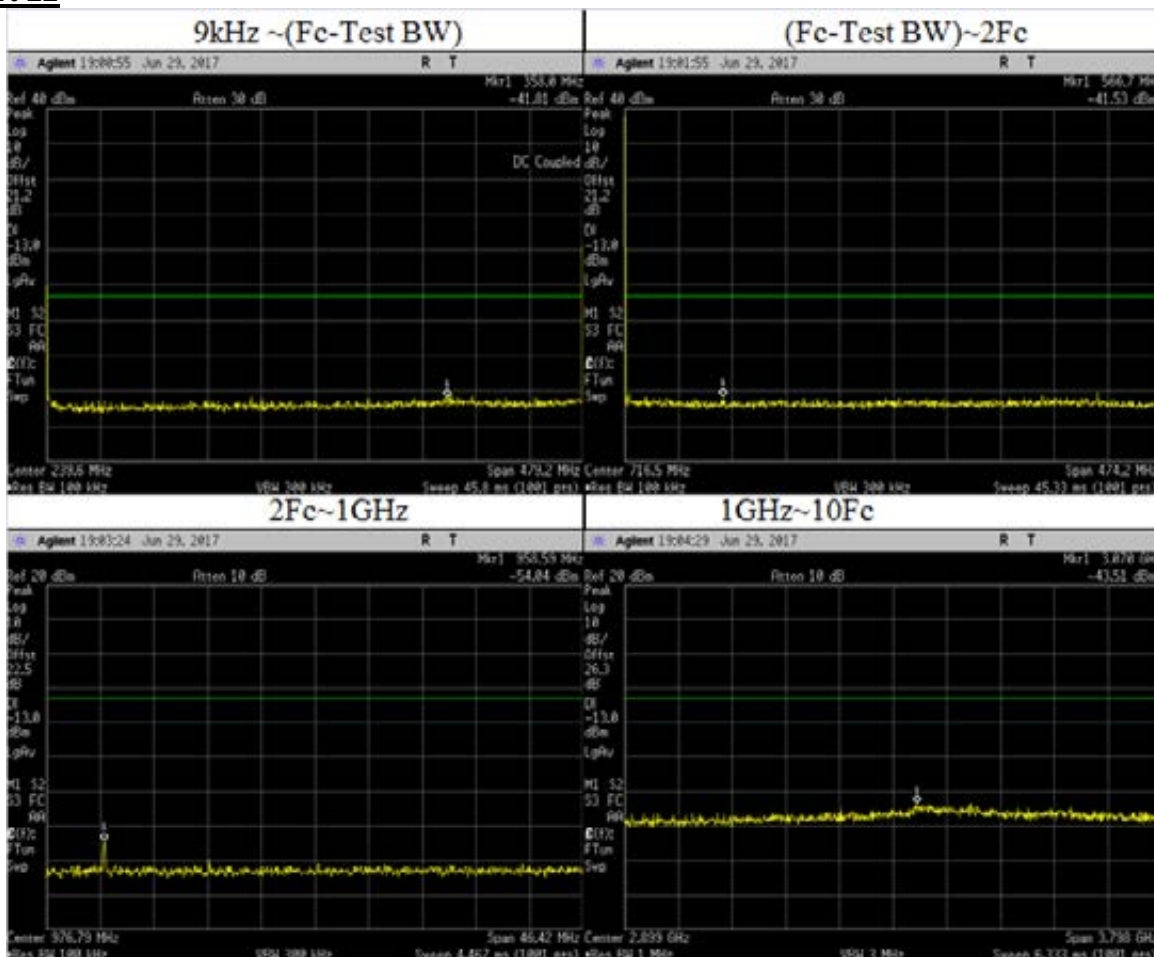

Frequency Range	Highest Spur Freq (MHz)	Spurious Level (dBm)	Failing Limit (dBm)	Remark
9kHz ~ (Fc-Test BW)	355.0000	-41.81	-13	Pass
(Fc-Test BW)~2Fc	566.7000	-41.53	-13	Pass
2Fc~1GHz	958.5900	-54.04	-13	Pass
1GHz~10Fc	30740.000	-43.51	-13	Pass
	1437.8630	-46.98		
	1917.1500	-48.20		
	2396.4380	-47.52		
	2875.7250	-46.83		
	3355.0130	-45.17		
	3834.3000	-46.91		
4313.5880	-48.00			
4792.8750	-47.97			

**Analog: 467.7750 MHz, 25.0 kHz Channel Spacing, Max Power
 Part 80 and RSS 119**

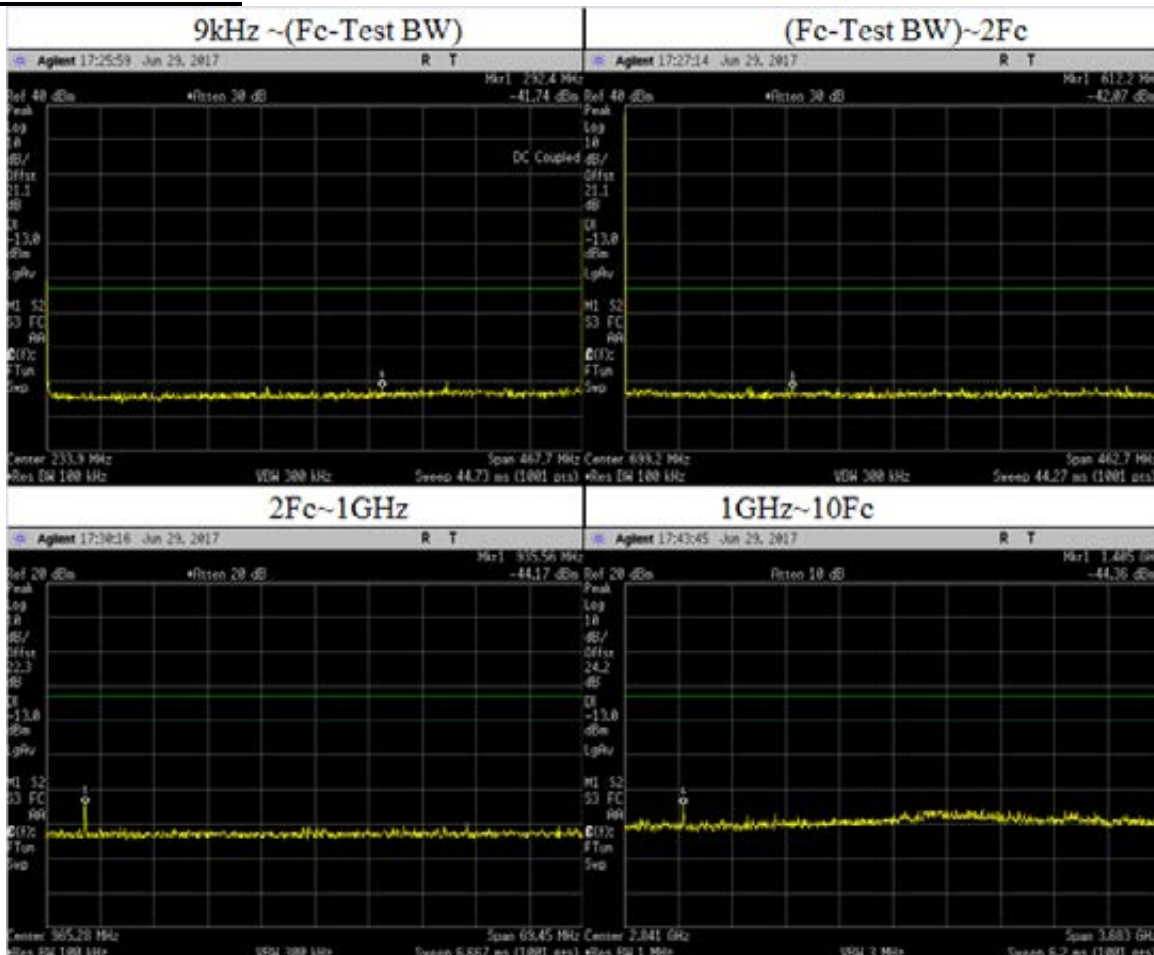

Frequency Range	Highest Spur Freq (MHz)	Spurious Level (dBm)	Failing Limit (dBm)	Remark
9kHz ~ (Fc-Test BW)	292.4000	-41.74	-13	Pass
(Fc-Test BW)~2Fc	612.2000	-42.07	-13	Pass
2Fc~1GHz	935.5600	-44.17	-13	Pass
1GHz~10Fc	1403.3250	-44.36	-13	Pass
	1871.1000	-49.88		
	2338.8750	-49.42		
	2806.6500	-49.22		
	3274.4250	-47.27		
	3742.2000	-48.01		
	4209.9750	-50.02		
	4677.7500	-50.10		

**Analog: 467.7750 MHz, 25.0 kHz Channel Spacing, Low Power
 Part 80 and RSS 119**

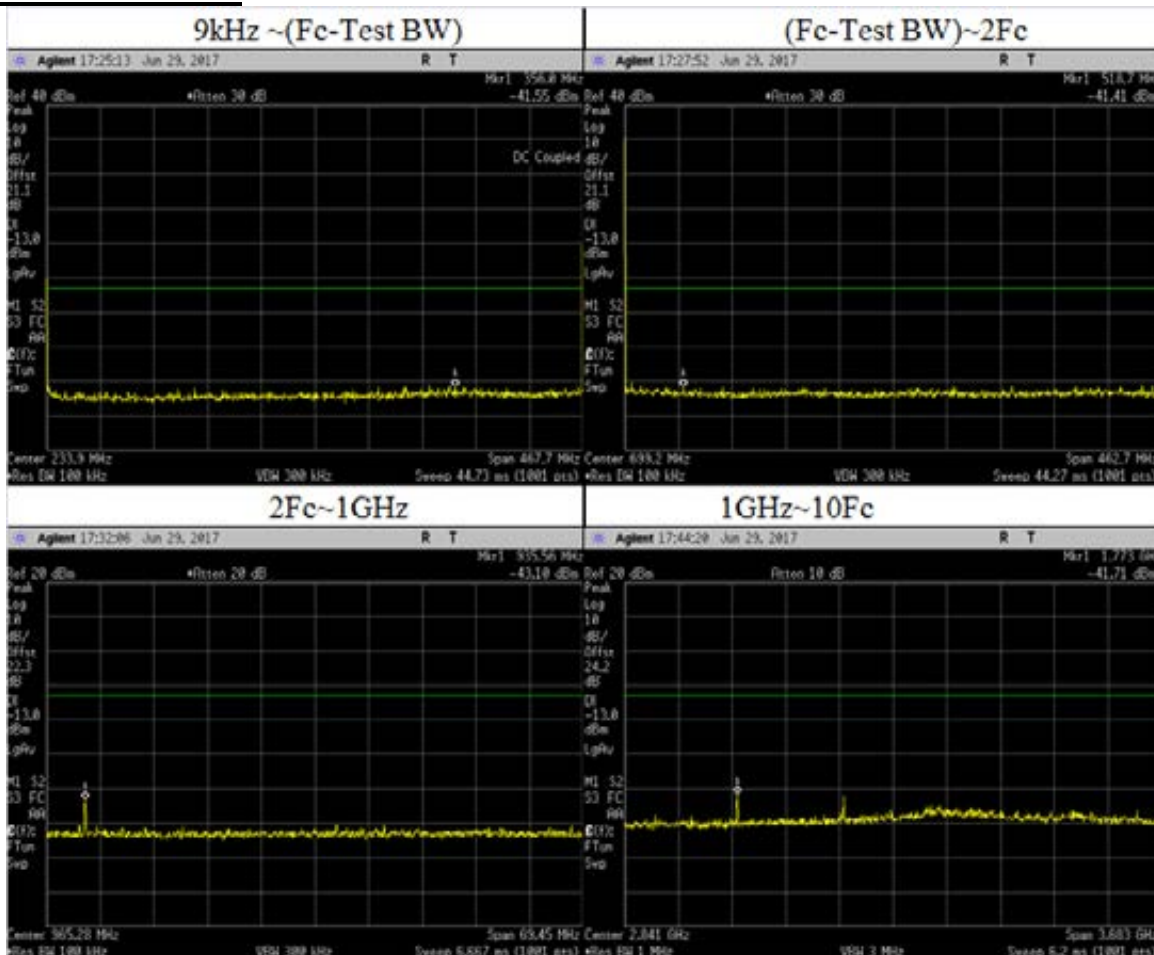

Frequency Range	Highest Spur Freq (MHz)	Spurious Level (dBm)	Failing Limit (dBm)	Remark
9kHz ~ (Fc-Test BW)	356.0000	-41.55	-13	Pass
(Fc-Test BW)~2Fc	518.7000	-41.41	-13	Pass
2Fc~1GHz	935.5600	-43.10	-13	Pass
1GHz~10Fc	1772.9300	-41.71	-13	Pass
	2502.1640	-42.08		
	1403.3250	-48.52		
	1871.1000	-49.68		
	2338.8750	-50.21		
	2806.6500	-48.49		
	3274.4250	-45.55		
	3742.2000	-48.46		
4209.9750	-48.12			
4677.7500	-47.68			

**Analog: 511.9875 MHz, 25.0 kHz Channel Spacing, Max Power
 Part 90**

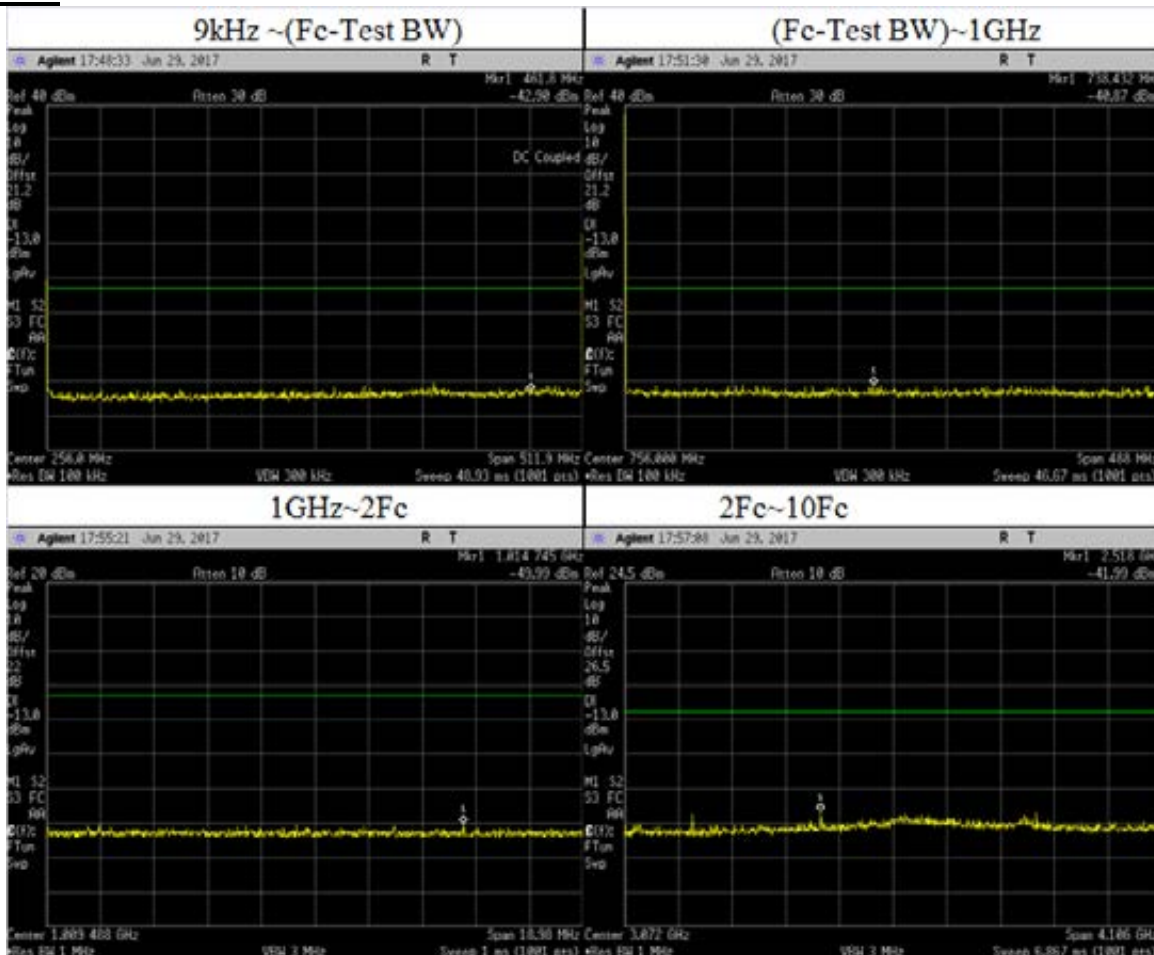

Frequency Range	Highest Spur Freq (MHz)	Spurious Level (dBm)	Failing Limit (dBm)	Remark
9kHz ~ (Fc-Test BW)	461.8000	-42.90	-13	Pass
(Fc-Test BW)~1GHz	738.4320	-40.87	-13	Pass
1GHz~2Fc	1014.7450	-49.99	-13	Pass
2Fc~10Fc	1536.3560	-42.83	-13	Pass
	2517.6900	-41.99		
	4168.3020	-42.58		
	1023.9750	-46.25		
	1535.9625	-42.83		
	2047.9500	-47.31		
	2559.9375	-46.91		
	3071.9250	-45.15		
	3583.9125	-45.83		
	4095.9000	-46.16		
4607.8875	-47.40			
5119.8750	-47.21			

**Analog: 511.9875 MHz, 25.0 kHz Channel Spacing, Low Power
 Part 90**

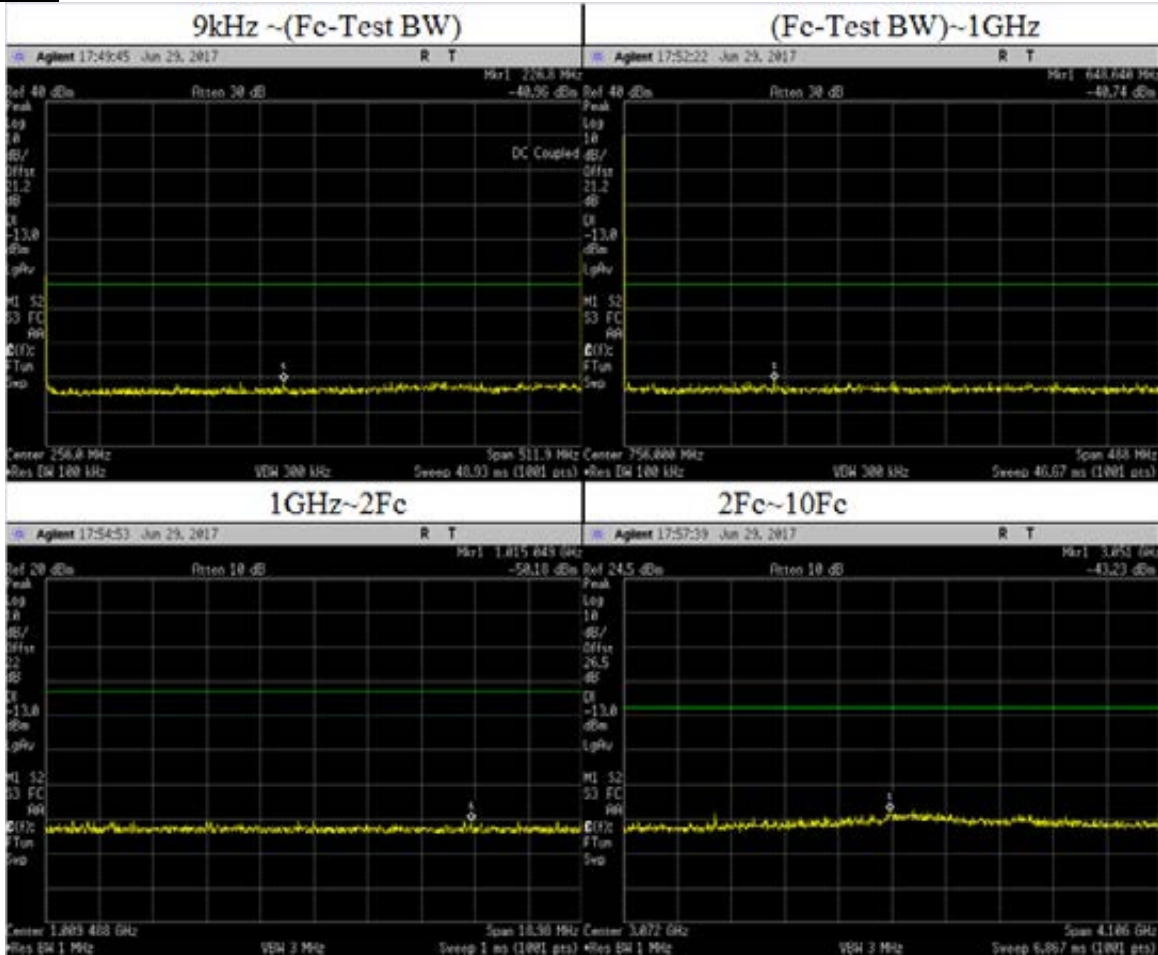

Frequency Range	Highest Spur Freq (MHz)	Spurious Level (dBm)	Failing Limit (dBm)	Remark
9kHz ~ (Fc-Test BW)	226.8000	-40.96	-13	Pass
(Fc-Test BW)~1GHz	648.6400	-40.74	-13	Pass
1GHz~2Fc	1015.0490	-50.18	-13	Pass
2Fc~10Fc	1023.9750	-47.85	-13	Pass
	1535.9625	-46.87		
	2047.9500	-47.29		
	2559.9375	-44.65		
	3071.9250	-44.28		
	3583.9125	-45.69		
	4095.9000	-45.73		
	4607.8875	-46.81		
	5119.8750	-46.01		

**Analog: 519.9875 MHz, 25.0 kHz Channel Spacing, Max Power (NOT FOR FCC REVIEW)
 Federal Frequency**

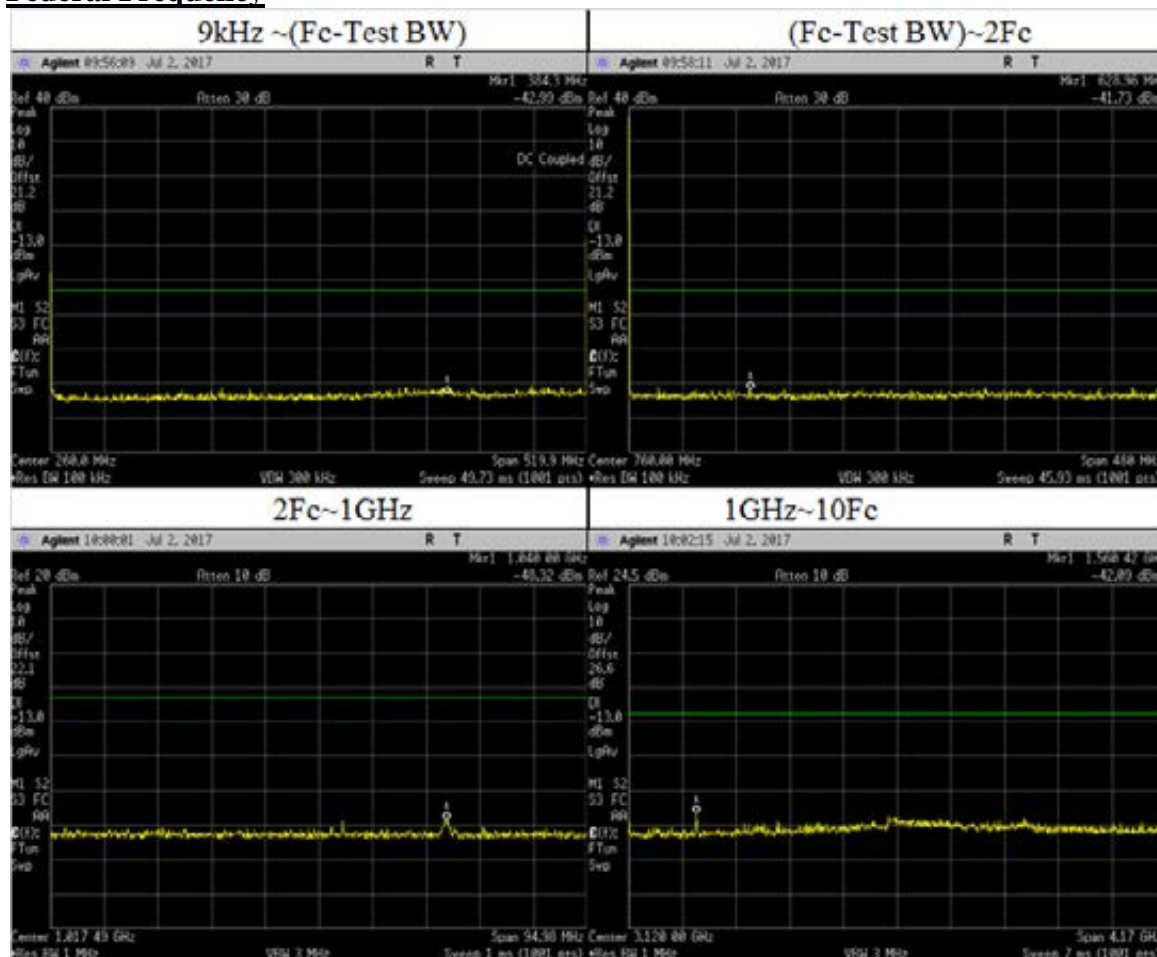

Frequency Range	Highest Spur Freq (MHz)	Spurious Level (dBm)	Failing Limit (dBm)	Remark
9kHz ~ (Fc-Test BW)	384.3000	-42.99	-13	Pass
(Fc-Test BW)~1GHz	628.9600	-41.73	-13	Pass
1GHz~2Fc	1040.0000	-48.32	-13	Pass
2Fc~10Fc	1560.4200	-42.09	-13	Pass
	1039.9750	-44.65		
	1559.9625	-42.09		
	2079.9500	-47.86		
	2599.9375	-46.87		
	3119.9250	-44.53		
	3639.9125	-46.02		
4159.9000	-46.08			
4679.8875	-47.86			
5199.8750	-46.23			

**Analog: 459.1250 MHz, 20.0 kHz Channel Spacing, Max Power
 RSS 119**

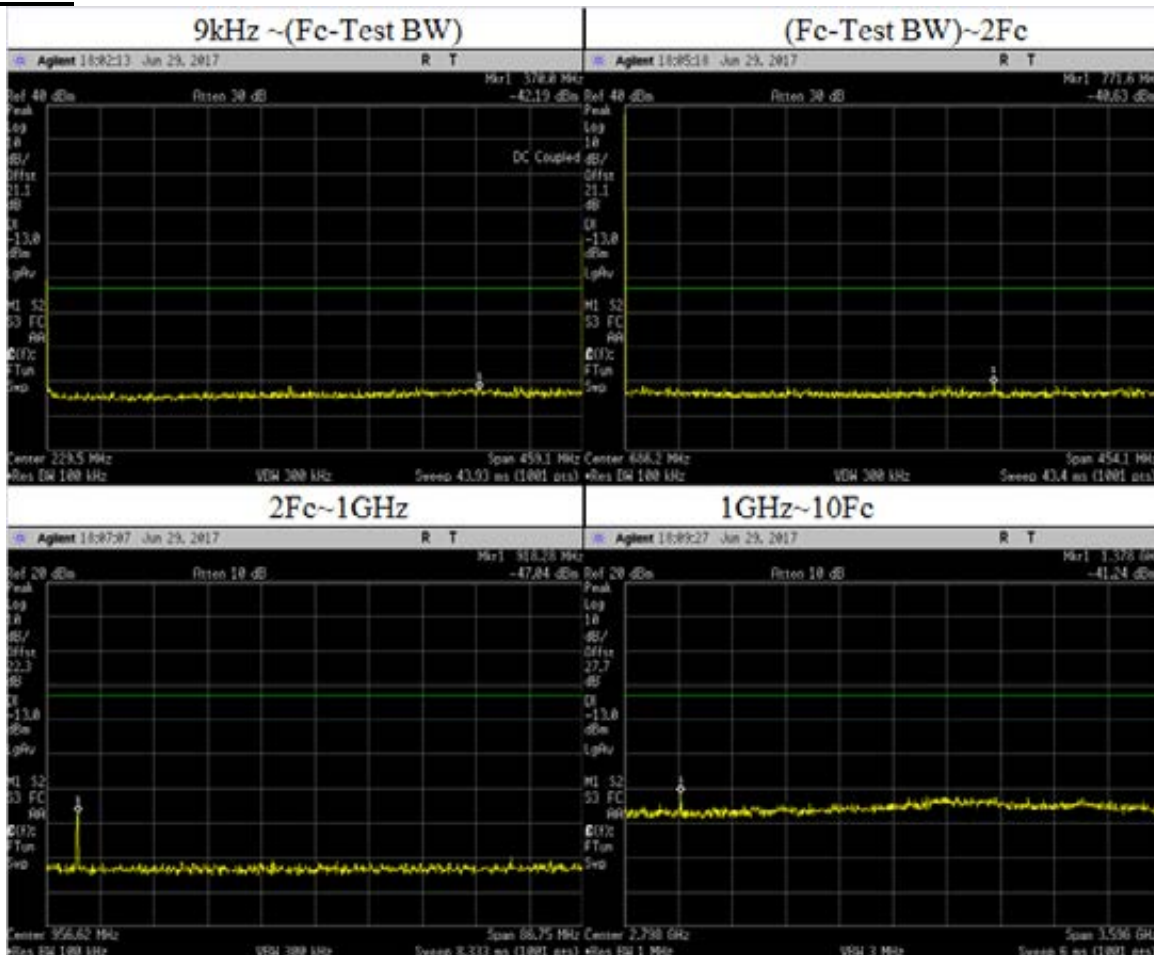

Frequency Range	Highest Spur Freq (MHz)	Spurious Level (dBm)	Failing Limit (dBm)	Remark
9kHz ~ (Fc-Test BW)	370.0000	-42.19	-13	Pass
(Fc-Test BW)~2Fc	771.6000	-40.63	-13	Pass
2Fc~1GHz	918.2800	-47.04	-13	Pass
1GHz~10Fc	1377.5800	-41.24	-13	Pass
	1377.3750	-41.24		
	1836.5000	-47.22		
	2295.6250	-44.77		
	2754.7500	-45.45		
	3213.8750	-42.42		
	3673.0000	-45.27		
	4132.1250	-44.15		
	4591.2500	-46.79		

**Analog: 459.1250 MHz, 25.0 kHz Channel Spacing, Max Power
 RSS 119**

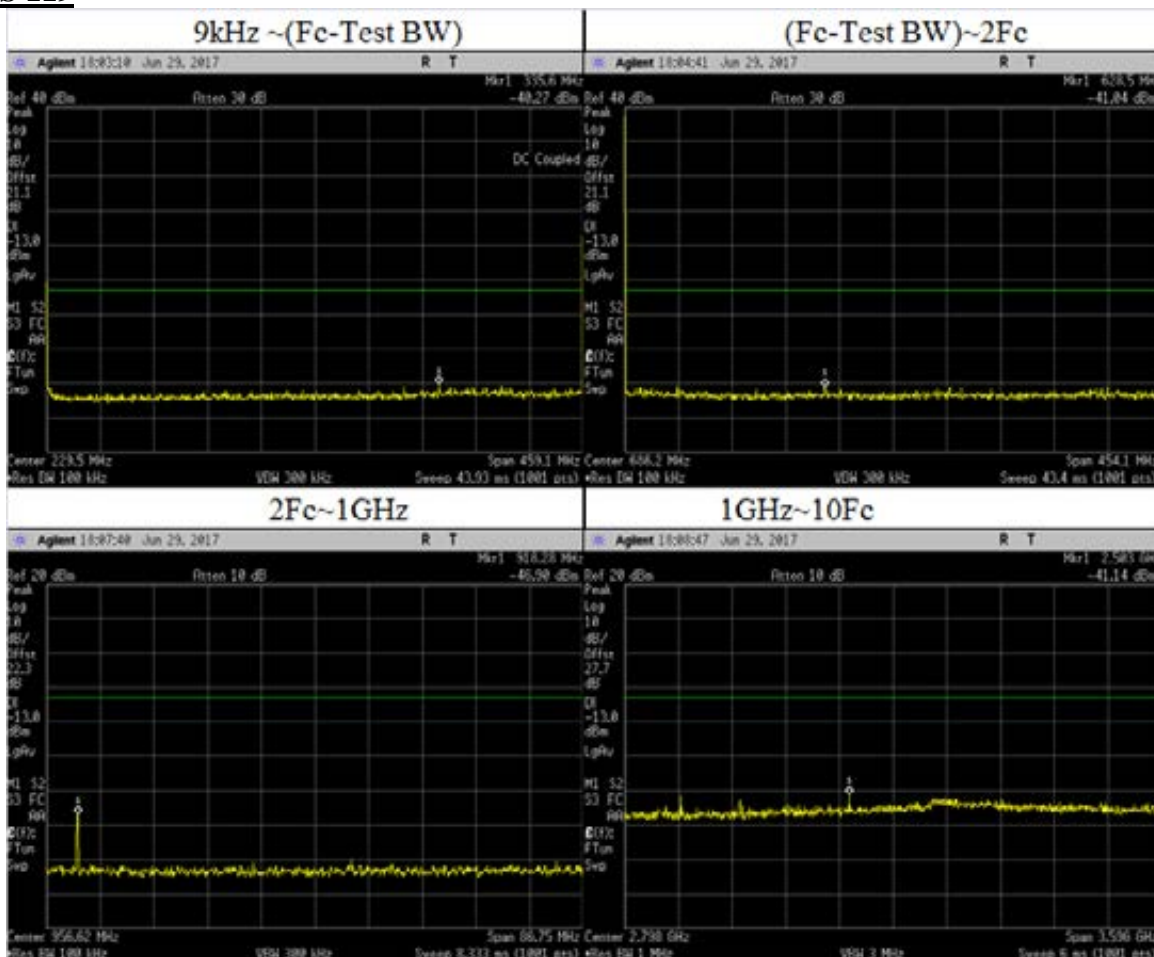

Frequency Range	Highest Spur Freq (MHz)	Spurious Level (dBm)	Failing Limit (dBm)	Remark
9kHz ~ (Fc-Test BW)	335.6000	-40.27	-13	Pass
(Fc-Test BW)~2Fc	628.5000	-41.04	-13	Pass
2Fc~1GHz	918.2800	-46.90	-13	Pass
1GHz~10Fc	1377.5800	-41.56	-13	Pass
	1773.1400	-42.66		
	2503.1280	-41.14		
	1377.3750	-41.56		
	1836.5000	-46.65		
	2295.6250	-46.10		
	2754.7500	-45.15		
	3213.8750	-44.45		
3673.0000	-45.20			
4132.1250	-44.27			
4591.2500	-45.04			

6.10.1. Test Result (Digital)

C4FM: 450.6500 MHz, 12.5 kHz Channel Spacing, Max Power Part 74,90 and RSS 119

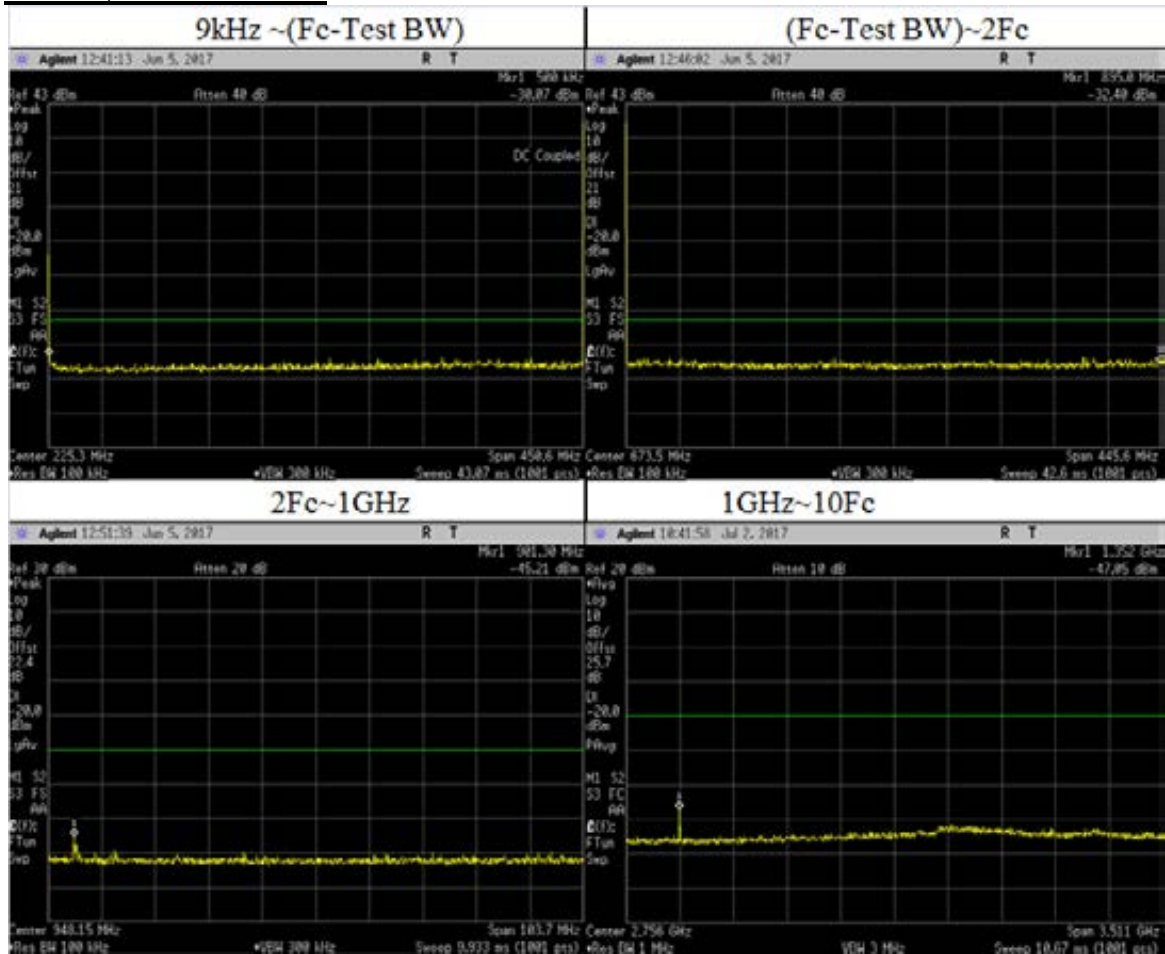

Frequency Range	Highest Spur Freq (MHz)	Spurious Level (dBm)	Failing Limit (dBm)	Remark
9kHz ~ (Fc-Test BW)	0.4600	-31.42	-20	Pass
	331.3100	-30.93		
	236.7800	-31.44		
	405.5800	-31.23		
	277.2900	-31.44		
(Fc-Test BW)~1GHz	894.9600	-29.89	-20	Pass
	624.3100	-30.43		
	839.7700	-30.29		
	831.3100	-30.33		
	487.6500	-30.98		
1GHz~2Fc	901.3800	-45.34	-20	Pass
1GHz~10Fc	1351.9500	-45.20	-20	Pass
	1802.6000	-53.06		
	2253.2500	-53.05		
	2703.9000	-52.77		
	3154.5500	-50.57		
	3605.2000	-51.71		
	4055.8500	-51.72		
	4506.5000	-52.08		

**C4FM: 450.6500 MHz, 12.5 kHz Channel Spacing, Low Power
Part 74,90 and RSS 119**

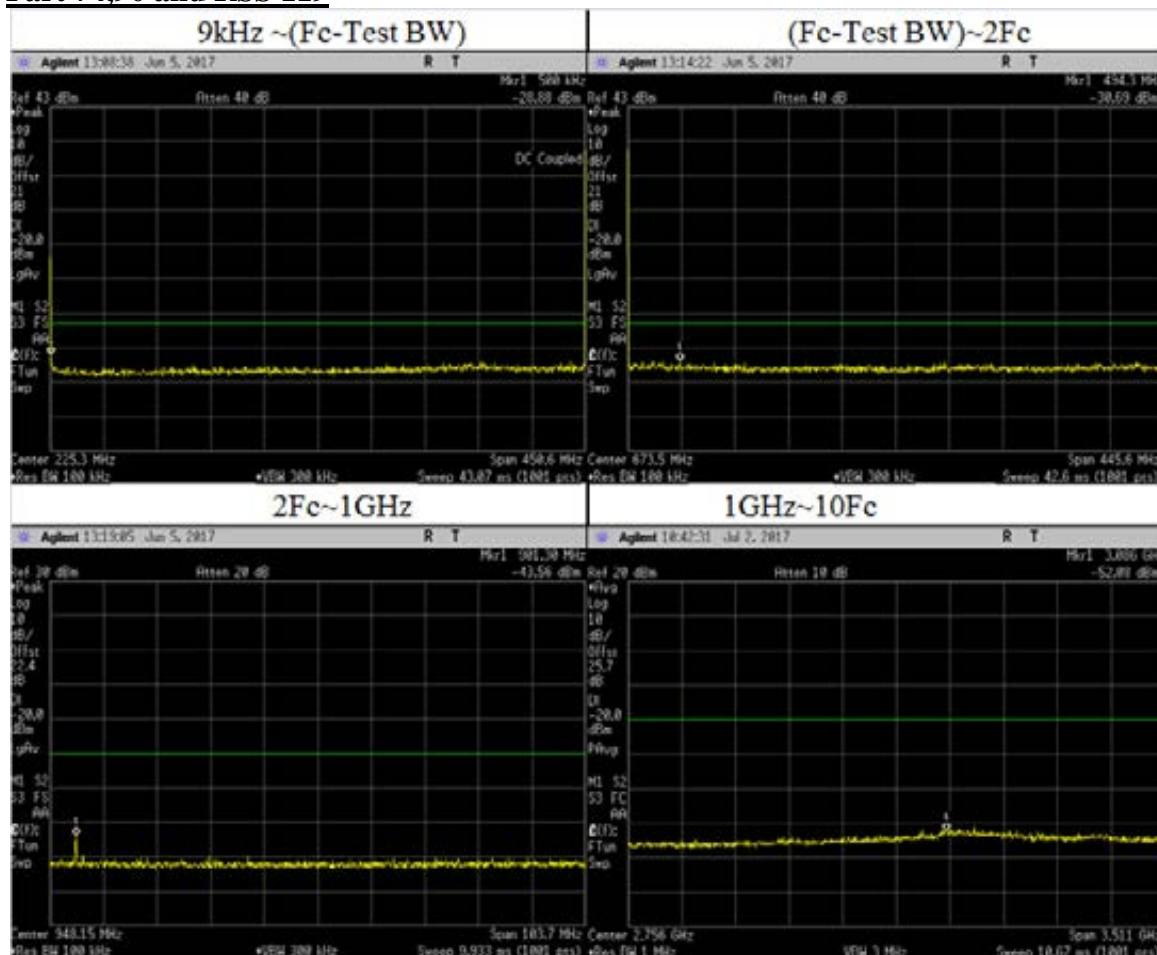

Frequency Range	Highest Spur Freq (MHz)	Spurious Level (dBm)	Failing Limit (dBm)	Remark
9kHz ~ (Fc-Test BW)	0.4600	-30.23	-20	Pass
	362.8200	-31.14		
	437.0900	-31.25		
	353.8200	-31.44		
	330.4100	-31.60		
(Fc-Test BW)~1GHz	494.3300	-30.47	-20	Pass
	471.6300	-30.68		
	873.6000	-30.32		
	713.7900	-30.73		
	480.0900	-31.02		
1GHz~2Fc	901.3800	-44.85	-20	Pass
1GHz~10Fc	1351.9500	-53.23	-20	Pass
	1802.6000	-54.63		
	2253.2500	-52.65		
	2703.9000	-52.33		
	3154.5500	-50.68		
	3605.2000	-51.64		
	4055.8500	-51.53		
	4506.5000	-53.06		

C4FM: 459.0250 MHz, 12.5 kHz Channel Spacing, Max Power
Part 22,90

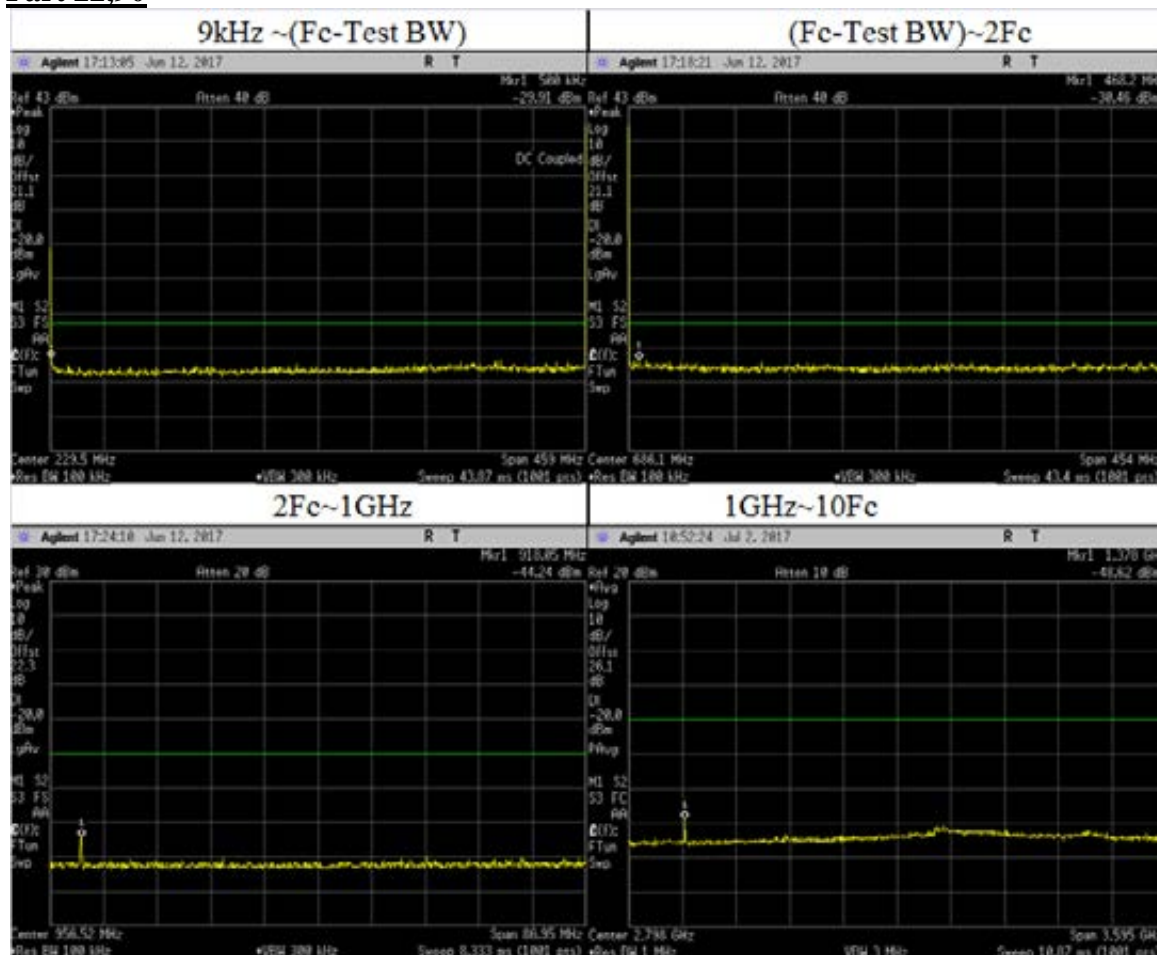

Frequency Range	Highest Spur Freq (MHz)	Spurious Level (dBm)	Failing Limit (dBm)	Remark
9kHz ~ (Fc-Test BW)	0.4700	-31.31	-20	Pass
	385.1500	-30.29		
	381.0200	-30.78		
	442.9200	-31.07		
	351.6800			
(Fc-Test BW)~1GHz	468.1500	-30.41	-20	Pass
	474.5000	-30.58		
	464.5200	-30.70		
	891.7300	-30.47		
	835.9500	-30.61		
1GHz~2Fc	918.0500	-44.35	-20	Pass
1GHz~10Fc	1378.0000	-48.62	-20	Pass
	1377.0750	-48.50		
	1836.1000	-55.84		
	2295.1250	-55.97		
	2754.8600	-54.71		
	3212.1750	-51.94		
	3672.2000	-53.63		
	4131.2250	-53.55		
	4590.2500	-53.67		

C4FM: 459.6500 MHz, 12.5 kHz Channel Spacing, Max Power
Part 22,90

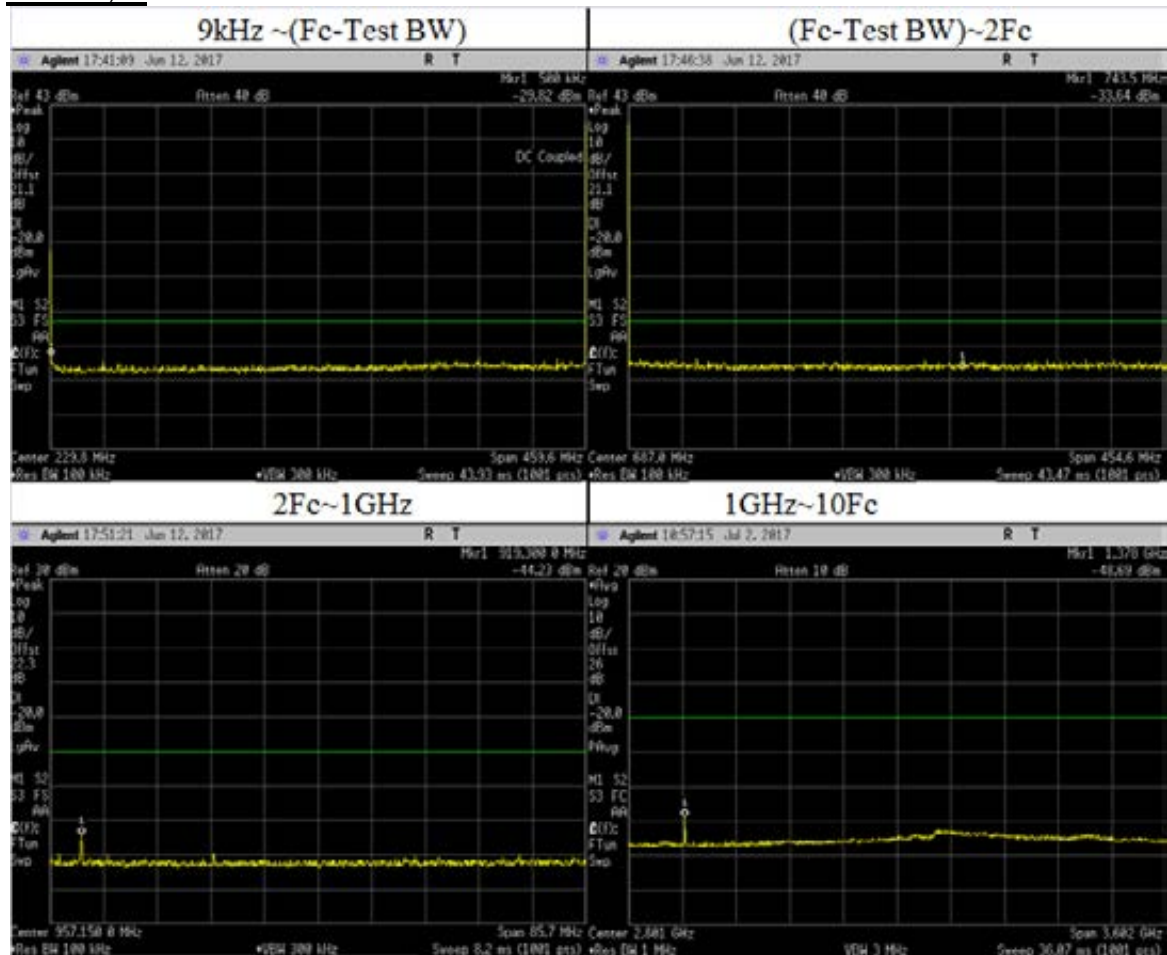

Frequency Range	Highest Spur Freq (MHz)	Spurious Level (dBm)	Failing Limit (dBm)	Remark
9kHz ~ (Fc-Test BW)	0.4700	-31.22	-20	Pass
	367.3100	-30.17		
	434.3400	-30.99		
	387.9700	-31.29		
	303.9500	-31.61		
(Fc-Test BW)~1GHz	743.5400	-30.05	-20	Pass
	517.8400	-30.49		
	469.7000	-30.80		
	814.8400	-30.56		
	710.8500	-30.80		
1GHz~2Fc	919.3000	-44.24	-20	Pass
1GHz~10Fc	1378.0000	-48.69	-20	Pass
	1378.9500	-48.57		
	1838.6000	-56.37		
	2298.2500	-56.27		
	2757.9000	-54.95		
	3217.5500	-53.16		
	4136.8500	-54.73		
	4596.5000	-55.47		

C4FM: 473.0125 MHz, 12.5 kHz Channel Spacing, Max Power
Part 22 and 90

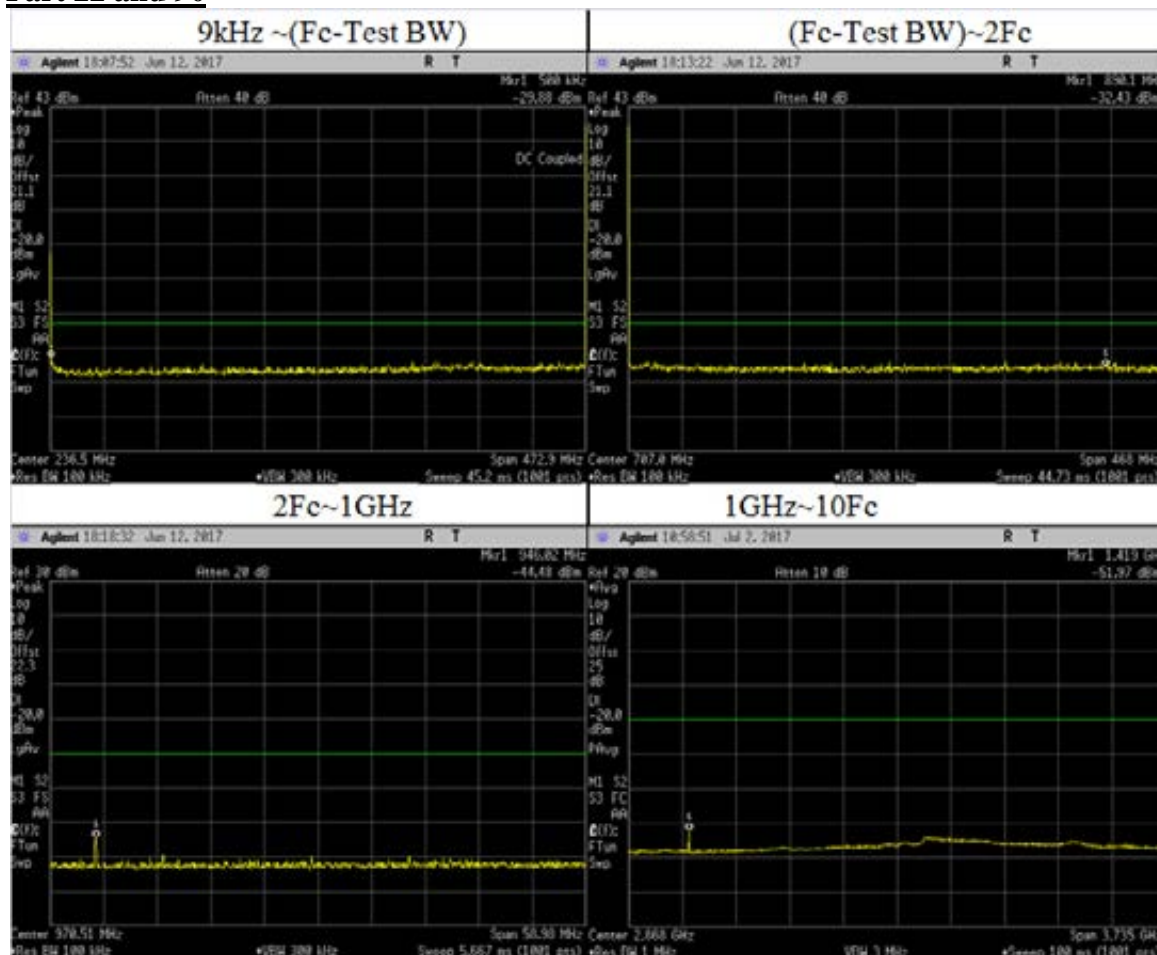

Frequency Range	Highest Spur Freq (MHz)	Spurious Level (dBm)	Failing Limit (dBm)	Remark
9kHz ~ (Fc-Test BW)	0.4800	-31.26	-20	Pass
	338.7700	-31.30		
	372.3200	-31.03		
	1.9000	-32.43		
	448.8600	-31.21		
(Fc-Test BW)~1GHz	890.0700	-30.29	-20	Pass
	802.6500	-30.40		
	489.9000	-30.91		
	850.3300	-30.45		
	496.9100	-30.98		
1GHz~2Fc	946.0200	-44.48	-20	Pass
1GHz~10Fc	1419.0380	-51.97	-20	Pass
	1892.0500	-57.79		
	2365.0630	-57.22		
	2838.0750	-56.20		
	3311.0900	-54.91		
	3784.0880	-55.75		
	4257.1130	-56.68		
	4730.1250	-57.09		

C4FM: 479.2875 MHz, 12.5 kHz Channel Spacing, Max Power
Part 22 and 90

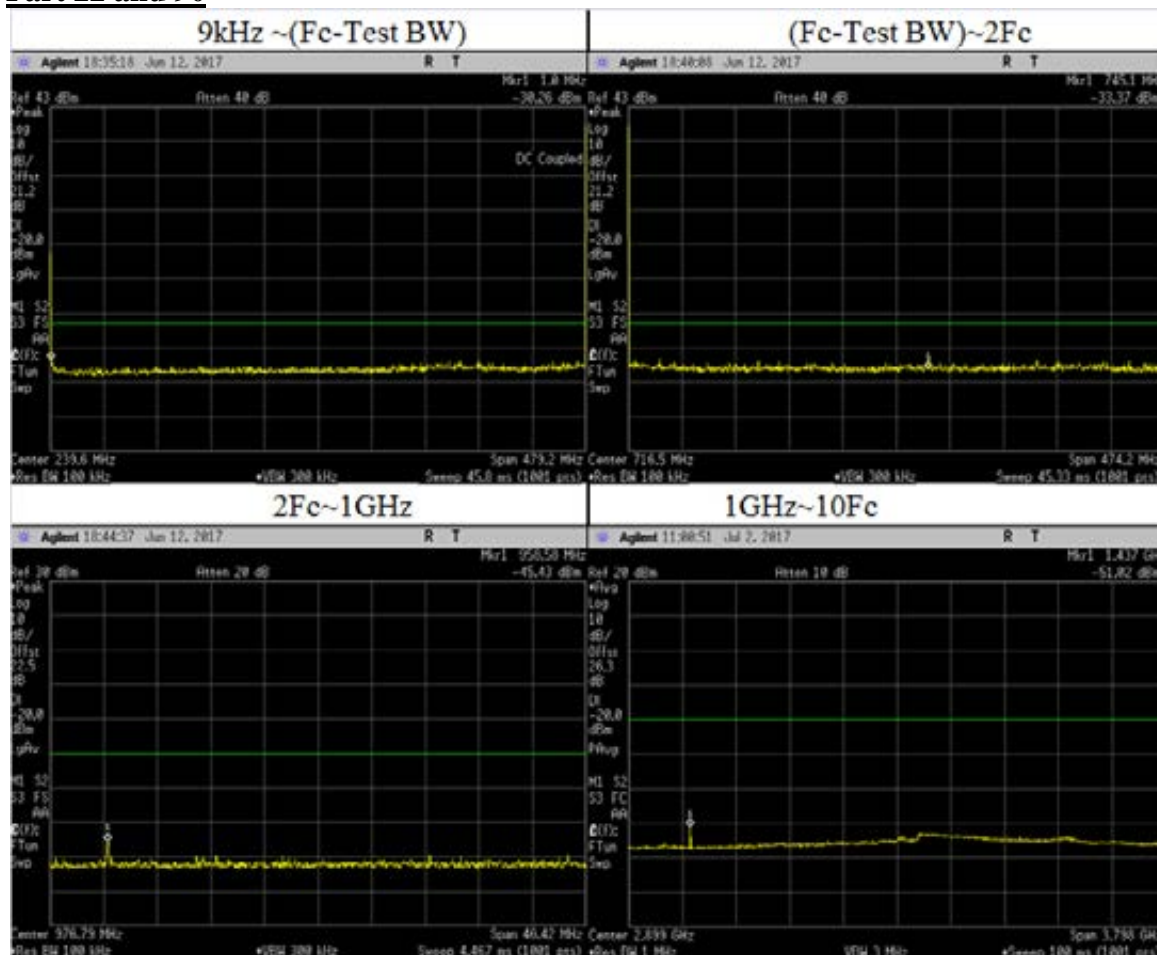

Frequency Range	Highest Spur Freq (MHz)	Spurious Level (dBm)	Failing Limit (dBm)	Remark
9kHz ~ (Fc-Test BW)	0.9700	-31.70	-20	Pass
	366.2500	-30.91		
	471.0900	-31.04		
	356.6700	-31.25		
	457.6900	-31.28		
(Fc-Test BW)~1GHz	745.1200	-29.48	-20	Pass
	506.8200	-30.11		
	840.8200	-29.98		
	922.3100	-30.12		
	593.9900	-30.66		
1GHz~2Fc	958.5800	-45.43	-20	Pass
1GHz~10Fc	1437.0000	-51.02	-20	Pass
	1437.8630	-51.02		
	1917.1500	-56.27		
	2396.4380	-56.06		
	2875.7250	-55.14		
	3355.0130	-53.71		
	3834.3000	-55.11		
	4313.5880	-55.57		
	4792.8750	-55.33		

**C4FM: 467.7750 MHz, 12.5 kHz Channel Spacing, Max Power
Part 80,90 and RSS 119**

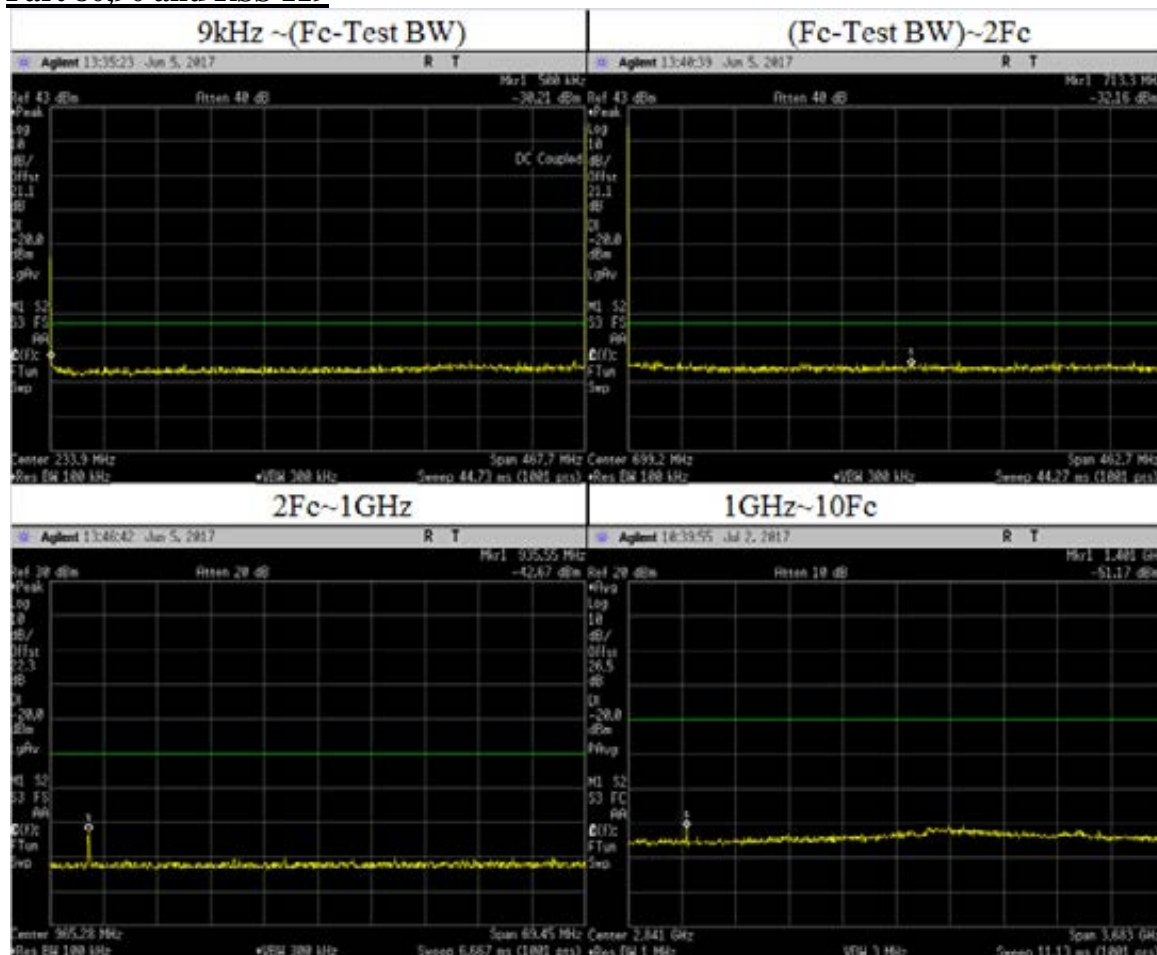

Frequency Range	Highest Spur Freq (MHz)	Spurious Level (dBm)	Failing Limit (dBm)	Remark
9kHz ~ (Fc-Test BW)	0.4800	-31.62	-20	Pass
	366.7900	-30.85		
	457.9100	-30.87		
	409.3100	-31.35		
	357.9200	-31.46		
(Fc-Test BW)~1GHz	713.2900	-30.35	-20	Pass
	904.6600	-30.11		
	688.3300	-30.54		
	493.7200	-30.81		
	753.5100	-30.51		
1GHz~2Fc	935.5500	-42.67	-20	Pass
1GHz~10Fc	1401.0000	-51.17	-20	Pass
	1403.3250	-49.98		
	1871.1000	-55.01		
	2338.8750	-54.02		
	2806.6500	-52.56		
	3274.4250	-51.94		
	3742.2000	-53.05		
	4209.9750	-53.33		
	4677.7500	-53.59		

**C4FM: 467.7750 MHz, 12.5 kHz Channel Spacing, Low Power
Part 80,90 and RSS 119**

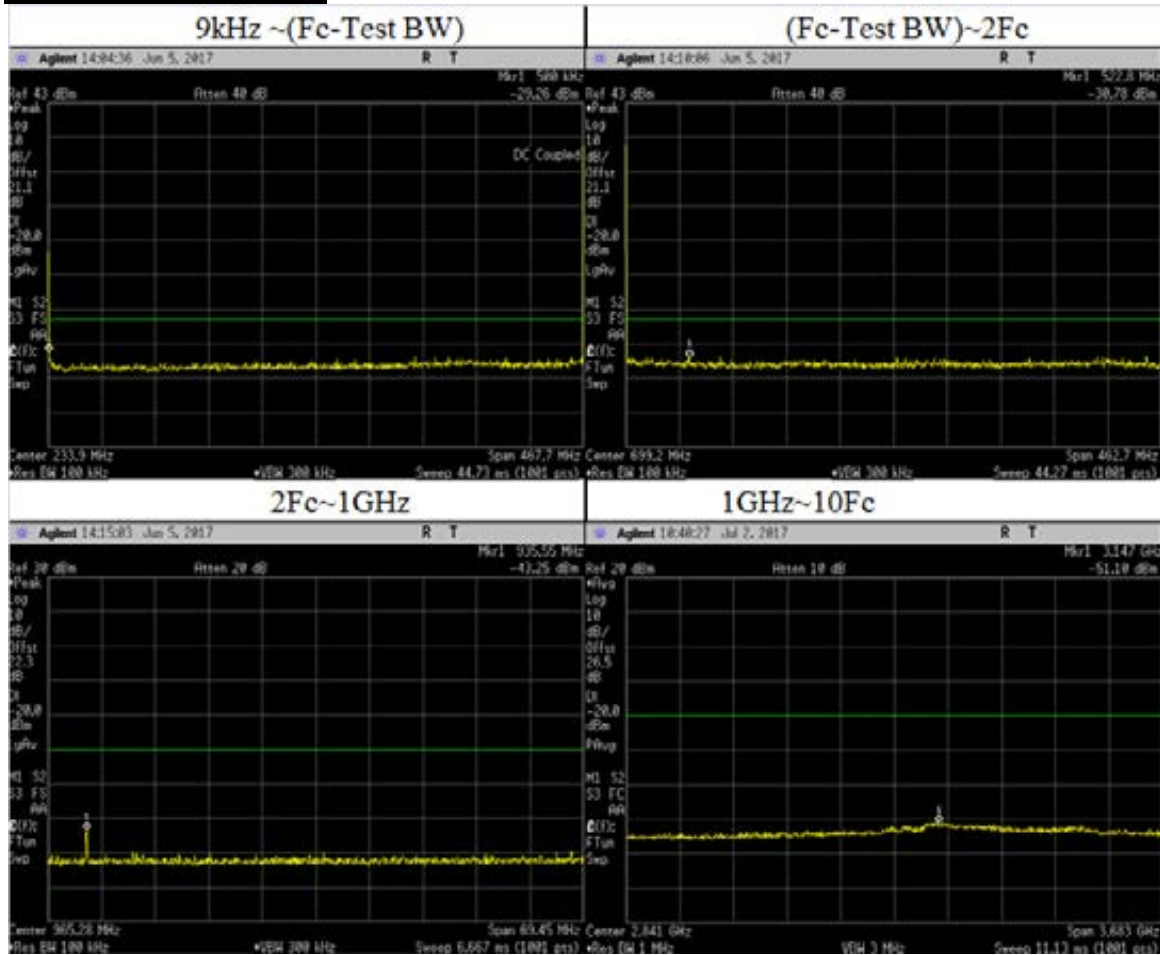

Frequency Range	Highest Spur Freq (MHz)	Spurious Level (dBm)	Failing Limit (dBm)	Remark
9kHz ~ (Fc-Test BW)	0.4800	-30.67	-20	Pass
	320.0700	-31.03		
	349.5100	-31.15		
	456.9700	-30.99		
	398.5700	-31.13		
(Fc-Test BW)~1GHz	522.8400	-30.63	-20	Pass
	486.3200	-30.72		
	879.7000	-30.27		
	549.1900	-30.81		
	917.1400	-30.28		
1GHz~2Fc	935.5500	-43.25	-20	Pass
1GHz~10Fc	3147.0000	-51.10	-20	Pass
	1403.3250	-56.05		
	1871.1000	-55.39		
	2338.8750	-52.99		
	2806.6500	-53.28		
	3274.4250	-52.86		
	3742.2000	-53.16		
	4209.9750	-54.22		
	4677.7500	-54.39		

C4FM: 511.9875 MHz, 12.5 kHz Channel Spacing, Max Power
Part 90

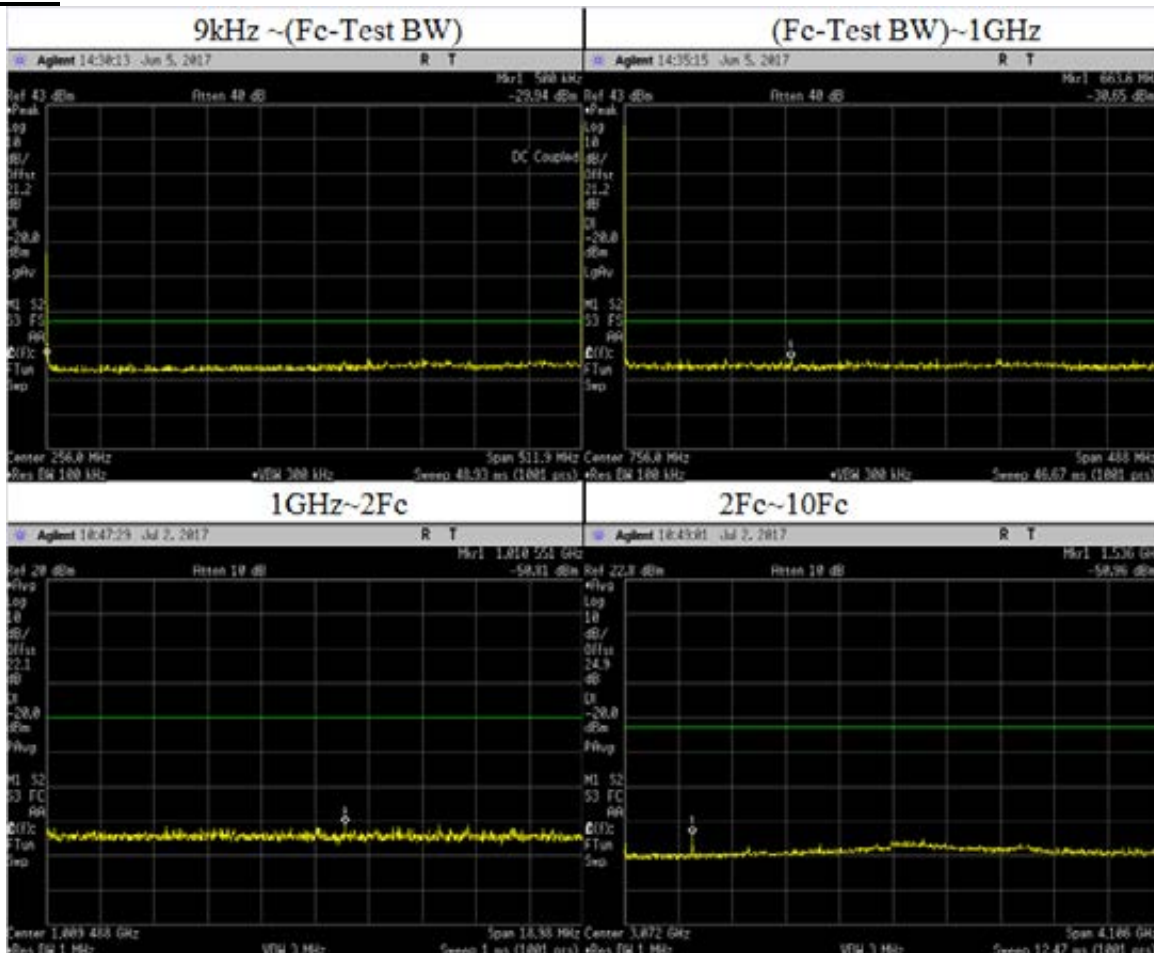

Frequency Range	Highest Spur Freq (MHz)	Spurious Level (dBm)	Failing Limit (dBm)	Remark
9kHz ~ (Fc-Test BW)	0.5200	-31.46	-20	Pass
	1.5400	-31.43		
	359.5300	-31.19		
	306.8600	-31.43		
	471.0200	-31.26		
(Fc-Test BW)~1GHz	663.6500	-30.44	-20	Pass
	796.7300	-30.23		
	850.8300	-30.40		
	853.7600	-30.50		
	733.3500	-30.64		
1GHz~2Fc	1010.5510	-50.81	-20	Pass
1GHz~10Fc	1023.9750	-53.40	-20	Pass
	1535.9625	-50.96		
	2047.9500	-55.91		
	2559.9375	-55.33		
	3071.9250	-53.13		
	3583.9125	-55.52		
	4095.9000	-54.80		
	4607.8875	-56.30		
	5119.8750	-55.90		

**C4FM: 511.9875 MHz, 12.5 kHz Channel Spacing, Low Power
Part 90**

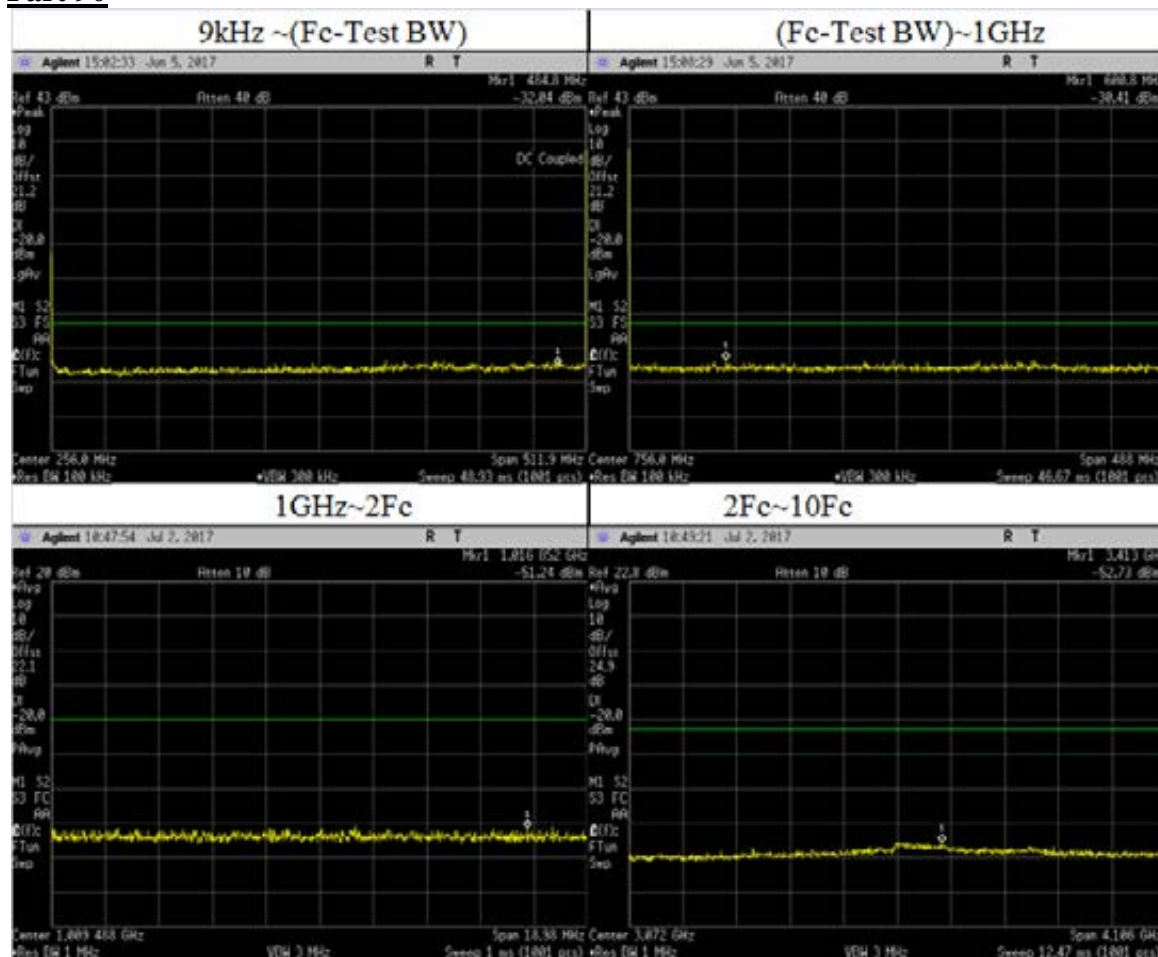

Frequency Range	Highest Spur Freq (MHz)	Spurious Level (dBm)	Failing Limit (dBm)	Remark
9kHz ~ (Fc-Test BW)	484.8300	-30.65	-20	Pass
	319.6400	-31.20		
	374.3600	-30.89		
	1.5400	-32.24		
	367.7100	-31.00		
(Fc-Test BW)~1GHz	600.7600	-30.31	-20	Pass
	752.8500	-30.22		
	880.5700	-30.18		
	855.7100	-30.32		
	727.0200	-30.52		
1GHz~2Fc	1016.8520	-51.24	-20	Pass
1GHz~10Fc	3413.0000	-52.73	-20	Pass
	1023.9750	-56.35		
	1535.9625	-56.69		
	2047.9500	-56.11		
	2559.9375	-55.70		
	3071.9250	-52.88		
	3583.9125	-55.62		
	4095.9000	-54.70		
	4607.8875	-55.67		
5119.8750	-56.22			

**C4FM: 519.9875 MHz, 12.5 kHz Channel Spacing, Max Power
Federal Frequency(Not For FCC Review)**

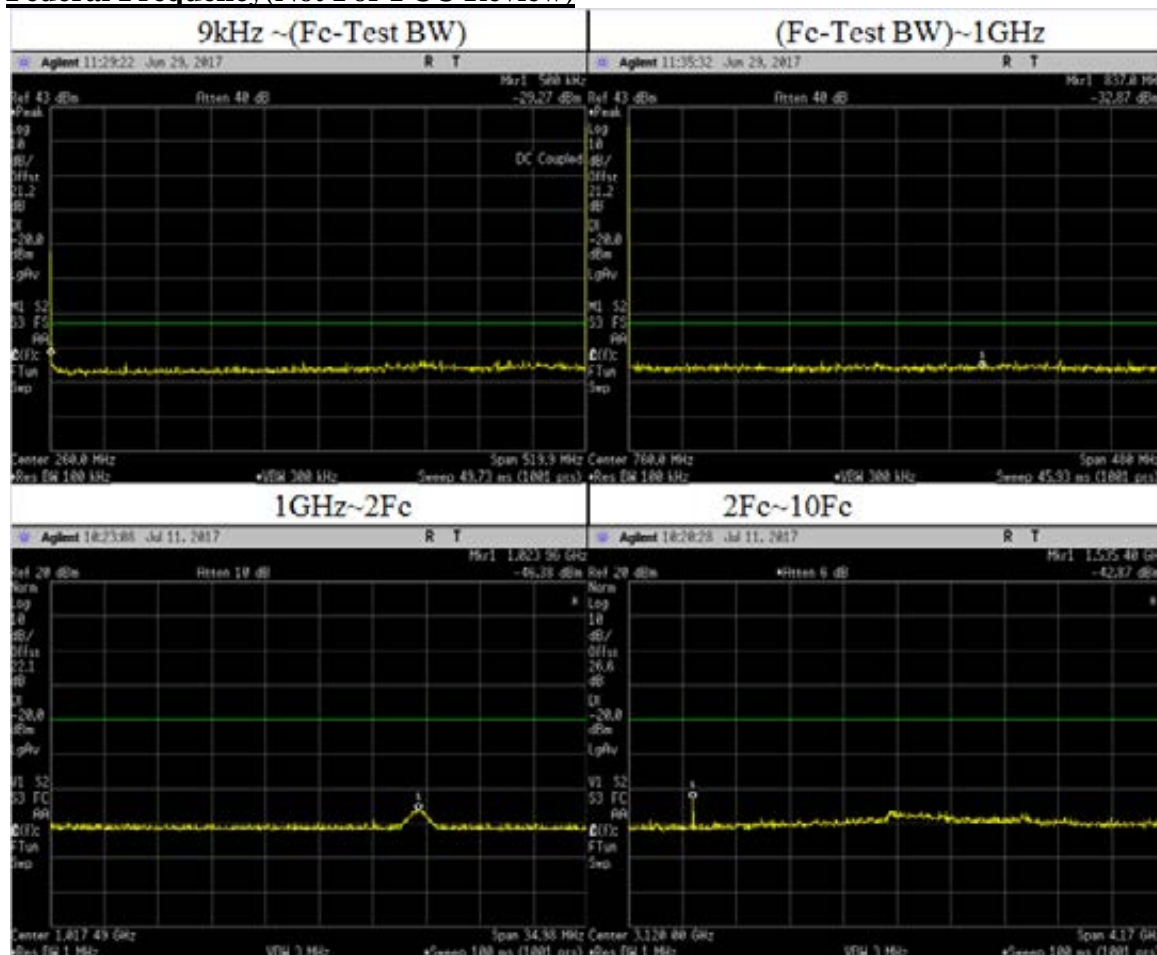

Frequency Range	Highest Spur Freq (MHz)	Spurious Level (dBm)	Failing Limit (dBm)	Remark
9kHz ~ (Fc-Test BW)	0.5300	-30.80	-20	Pass
	458.6400	-30.61		
	434.7500	-30.81		
	445.6600	-30.80		
	358.9200	-30.91		
(Fc-Test BW)~1GHz	836.9800	-30.00	-20	Pass
	906.5000	-29.89		
	968.3500	-30.17		
	693.1300	-30.74		
	866.2300	-30.52		
1GHz~2Fc	1023.9600	-46.38	-20	Pass
1GHz~10Fc	1535.4000	-42.87	-20	Pass
	1039.9750	-52.03		
	1559.9625	-51.25		
	2079.9500	-49.41		
	2599.9375	-49.52		
	3119.9250	-47.60		
	3639.9125	-49.48		
	4159.9000	-49.44		
	4679.8875	-49.46		
5199.8750	-50.00			

**C4FM: 459.1250 MHz, 12.5 kHz Channel Spacing, Max Power
RSS 119**

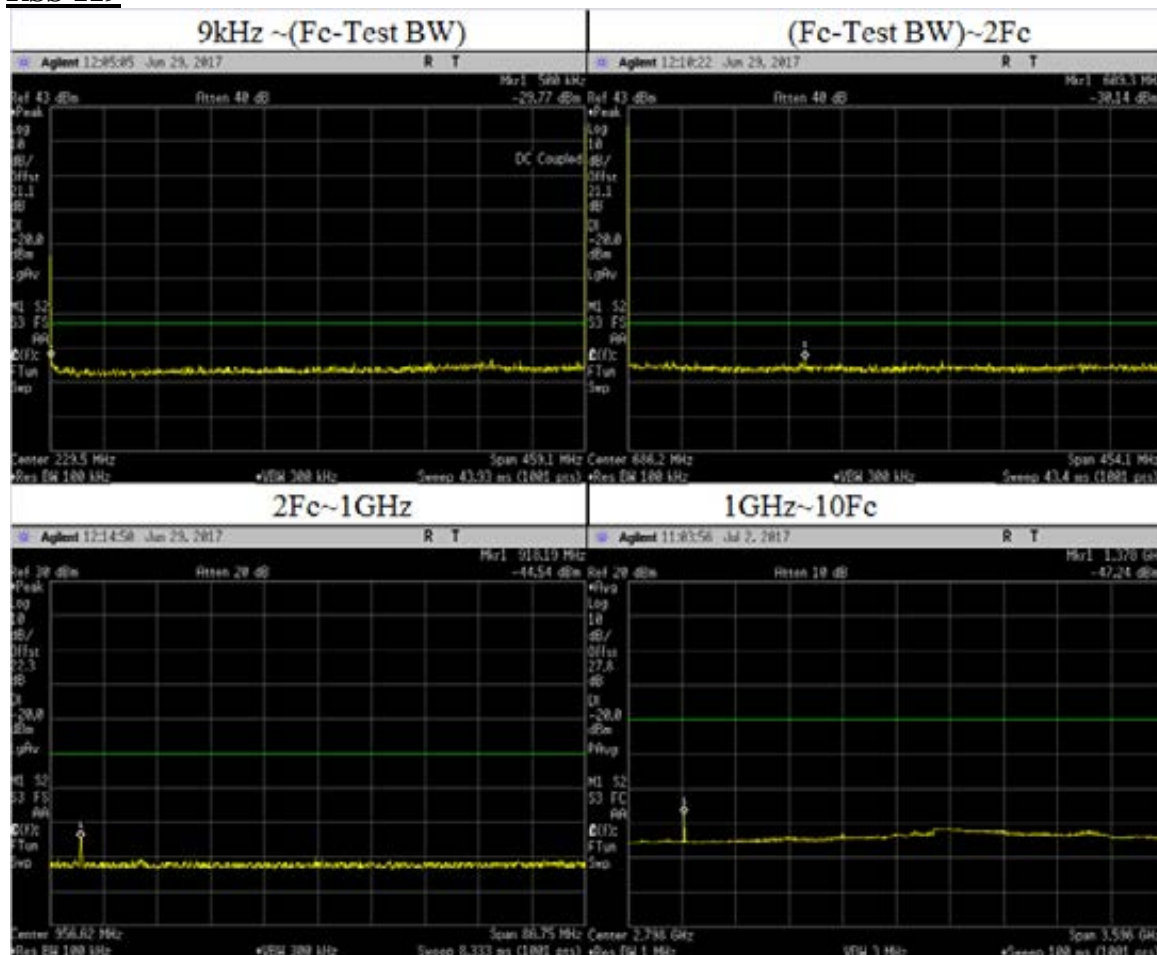

Frequency Range	Highest Spur Freq (MHz)	Spurious Level (dBm)	Failing Limit (dBm)	Remark
9kHz ~ (Fc-Test BW)	0.4700	-31.17	-20	Pass
	378.3600	-30.09		
	402.6600	-30.86		
	371.0200	-31.01		
	451.7300	-31.16		
(Fc-Test BW)~1GHz	609.3300	-29.89	-20	Pass
	725.0000	-30.26		
	497.2800	-30.69		
	605.7000	-30.84		
	693.7000	-30.71		
1GHz~2Fc	918.1900	-44.54	-20	Pass
	918.2500	-44.55		
1GHz~10Fc	1378.0000	-47.24	-20	Pass
	1377.3750	-54.21		
	1836.5000	-53.69		
	2295.6250	-53.15		
	2754.7500	-51.44		
	3213.8750	-50.28		
	3673.0000	-51.66		
	4132.1250	-51.91		
	4591.2500	-53.06		

**Phase II: 450.6500 MHz, 12.5 kHz Channel Spacing, Max Power
Part 74.90 and RSS 119**

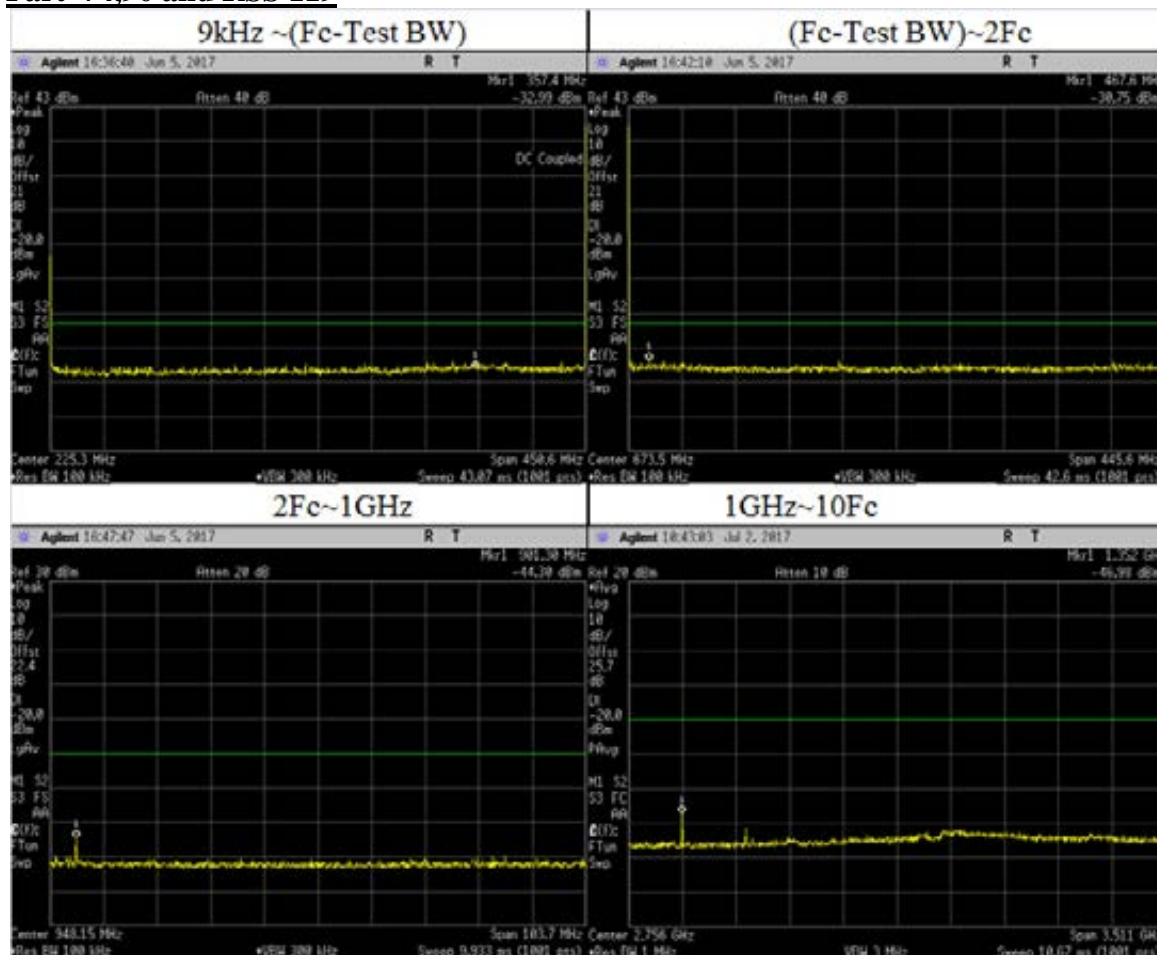

Frequency Range	Highest Spur Freq (MHz)	Spurious Level (dBm)	Failing Limit (dBm)	Remark
9kHz ~ (Fc-Test BW)	357.4200	-30.83	-20	Pass
	0.4600	-32.19		
	338.5100	-31.15		
	429.8900	-31.20		
	322.3100	-31.67		
(Fc-Test BW)~1GHz	467.6200	-30.65	-20	Pass
	626.0900	-30.43		
	480.0900	-30.82		
	853.1200	-30.45		
	884.2800	-30.54		
1GHz~2Fc	901.3000	-44.30	-20	Pass
	901.3800	-44.75		
1GHz~10Fc	1352.0000	-46.98	-20	Pass
	1351.9500	-45.30		
	1802.6000	-53.82		
	2253.2500	-54.64		
	2703.9000	-52.76		
	3154.5500	-50.35		
	3605.2000	-52.34		
	4055.8500	-53.19		
	4506.5000	-53.28		

**Phase II: 450.6500 MHz, 12.5 kHz Channel Spacing, Low Power
Part 74, 90 and RSS 119**

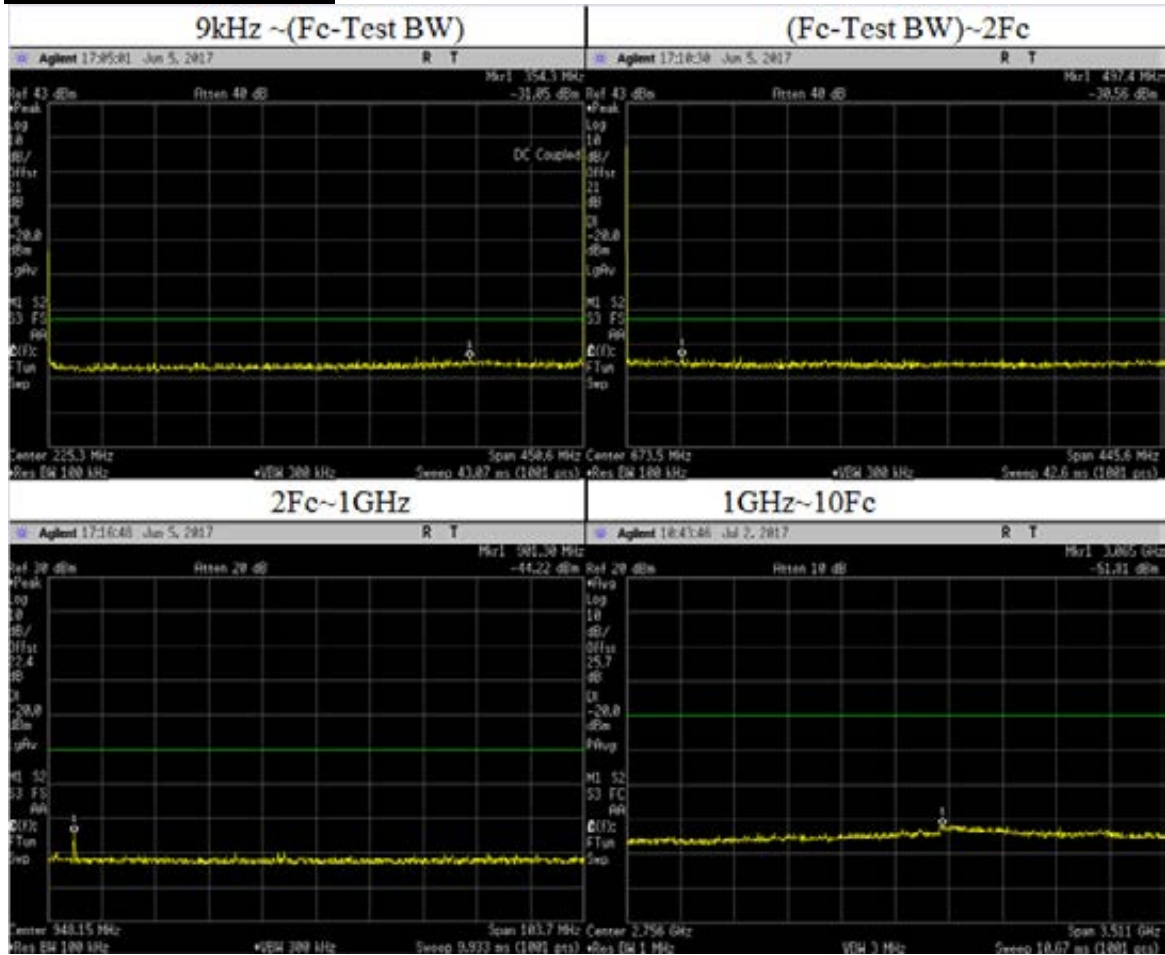

Frequency Range	Highest Spur Freq (MHz)	Spurious Level (dBm)	Failing Limit (dBm)	Remark
9kHz ~ (Fc-Test BW)	354.2700	-30.46	-20	Pass
	0.4600	-31.93		
	323.6600	-31.47		
	309.2500	-31.44		
	446.5400	-31.29		
(Fc-Test BW)~1GHz	497.4500	-30.36	-20	Pass
	545.5200	-30.37		
	483.2000	-30.88		
	638.1100	-30.98		
	514.3600	-31.14		
1GHz~2Fc	901.3000	-44.22	-20	Pass
1GHz~10Fc	3065.0000	-51.81	-20	Pass
	1351.9500	-55.65		
	1802.6000	-55.50		
	2253.2500	-55.42		
	2703.9000	-54.63		
	3154.5500	-51.75		
	3605.2000	-54.22		
	4055.8500	-53.92		
	4506.5000	-53.98		

Phase II: 459.0250 MHz, 12.5 kHz Channel Spacing, Max Power
Part 22,90

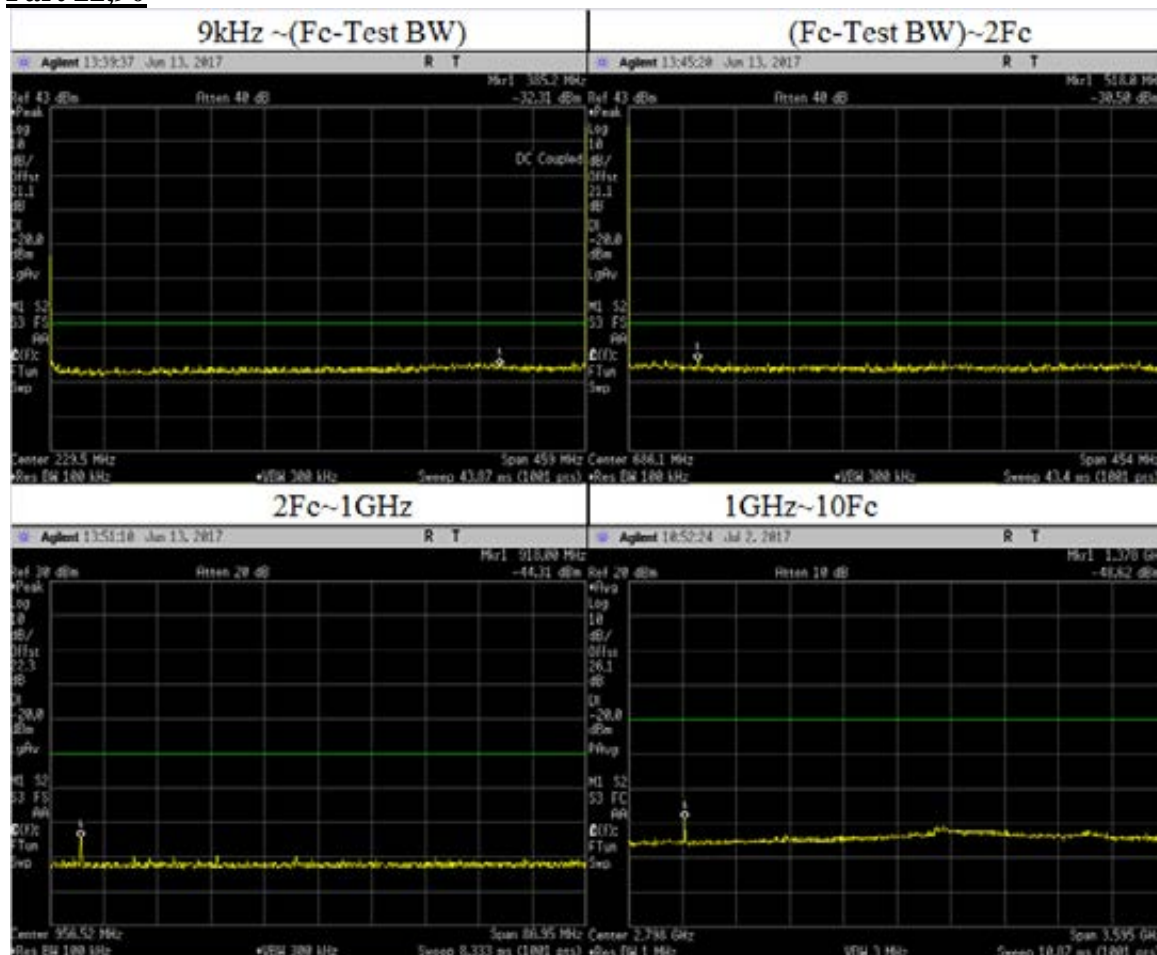

Frequency Range	Highest Spur Freq (MHz)	Spurious Level (dBm)	Failing Limit (dBm)	Remark
9kHz ~ (Fc-Test BW)	385.1500	-30.73	-20	Pass
	0.4700	-32.25		
	447.5100	-31.19		
	1.8400	-32.48		
	367.2700	-31.26		
(Fc-Test BW)~1GHz	518.0400	-30.37	-20	Pass
	491.2800	-30.37		
	490.3700	-30.66		
	726.2000	-30.42		
	714.8600	-30.67		
1GHz~2Fc	918.0000	-44.31	-20	Pass
1GHz~10Fc	1378.0000	-48.62	-20	Pass
	1377.0750	-48.62		
	1836.1000	-55.52		
	2295.1250	-54.86		
	2754.8600	-53.77		
	3212.1750	-52.33		
	3672.2000	-52.67		
	4131.2250	-53.49		
	4590.2500	-55.12		

Phase II: 459.6500 MHz, 12.5 kHz Channel Spacing, Max Power
Part 22,90

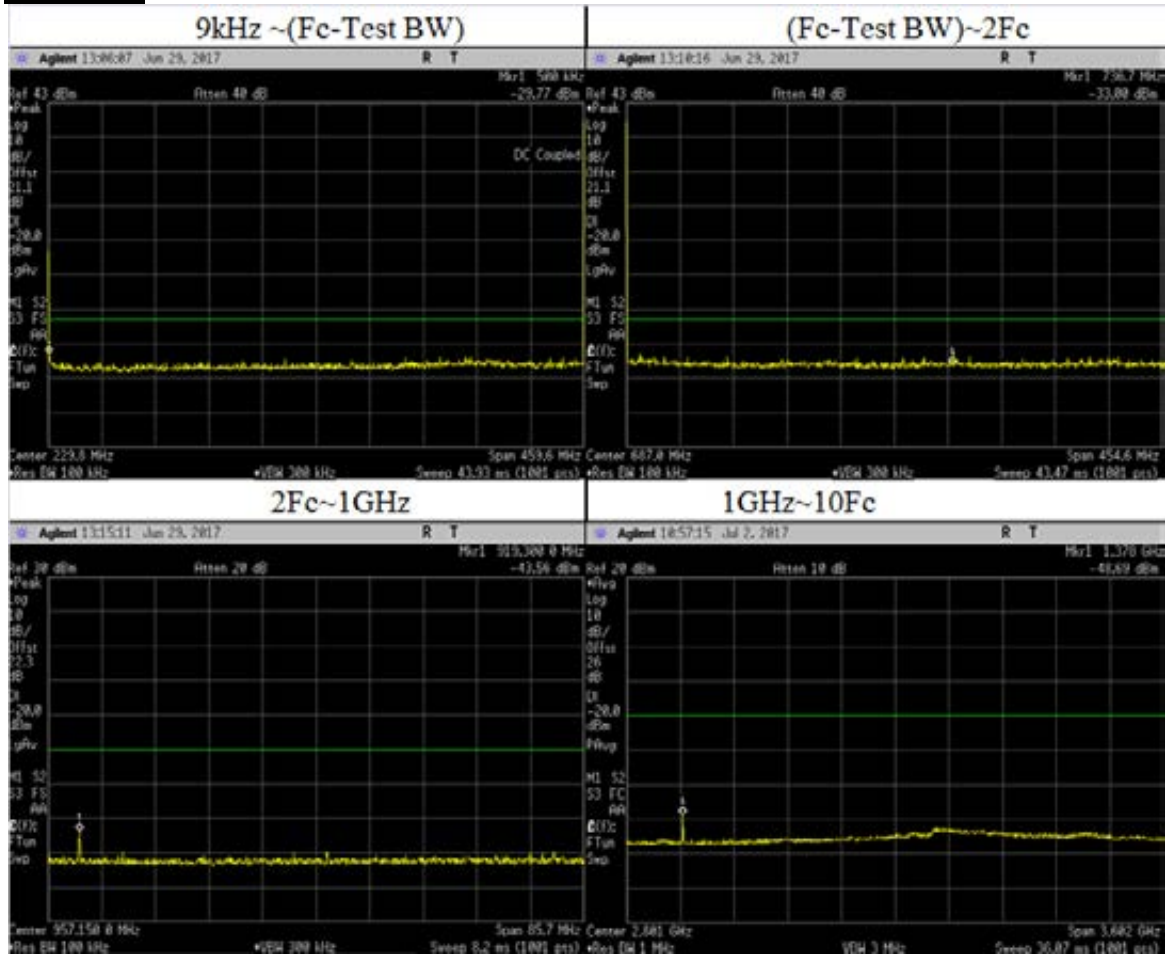

Frequency Range	Highest Spur Freq (MHz)	Spurious Level (dBm)	Failing Limit (dBm)	Remark
9kHz ~ (Fc-Test BW)	0.4700	-31.17	-20	Pass
	335.6300	-31.11		
	1.3900	-32.22		
	361.8000	-30.98		
	357.6700	-31.10		
(Fc-Test BW)~1GHz	736.7300	-28.83	-20	Pass
	471.5100	-29.81		
	491.9500	-30.54		
	545.5400	-30.62		
	750.3600	-30.23		
1GHz~2Fc	919.3000	-43.56	-20	Pass
1GHz~10Fc	1378.0000	-48.69	-20	Pass
	1378.9500	-48.99		
	1838.6000	-56.48		
	2298.2500	-55.92		
	2757.9000	-55.73		
	3217.5500	-53.60		
	4136.8500	-54.75		
	4596.5000	-56.17		

Phase II: 473.0125 MHz, 12.5 kHz Channel Spacing, Max Power
Part 22, 90

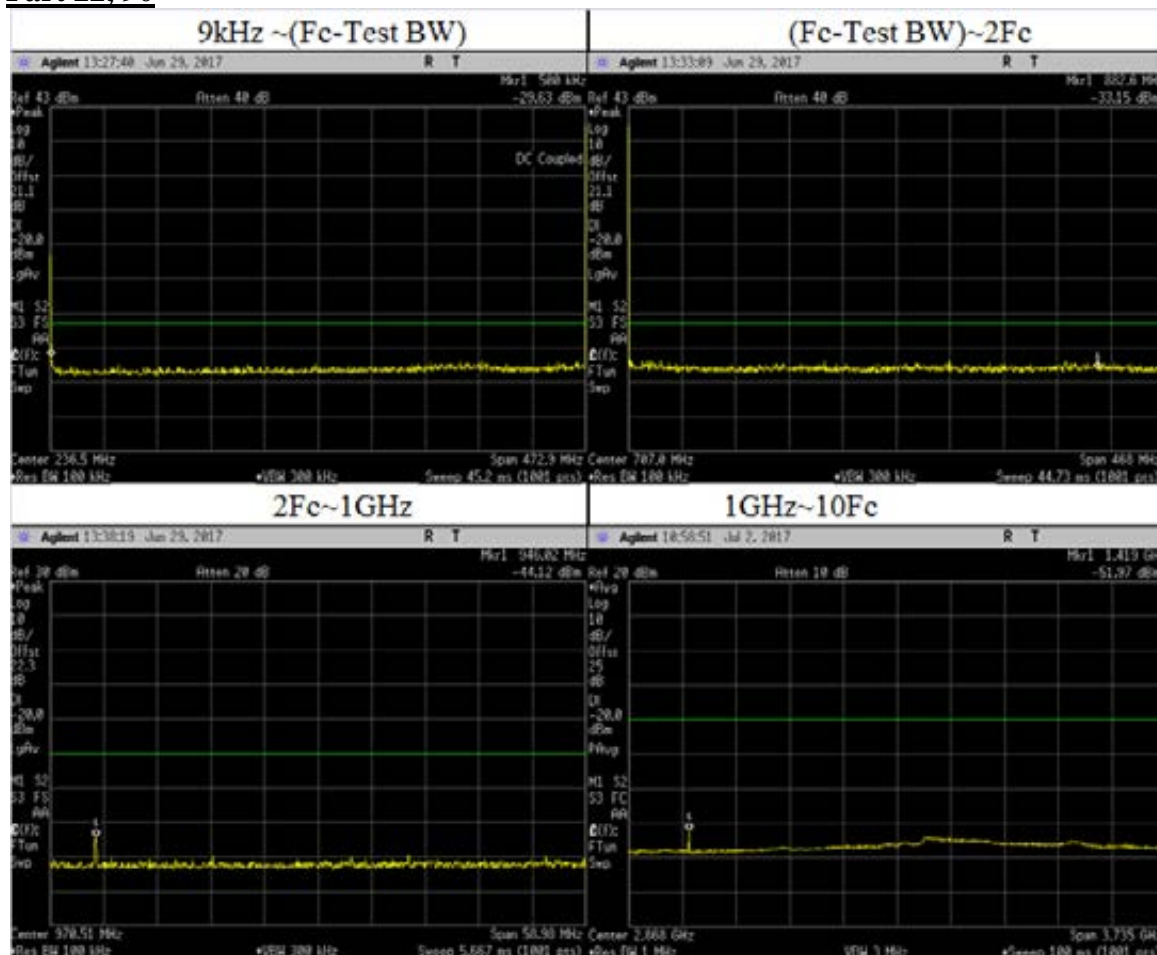

Frequency Range	Highest Spur Freq (MHz)	Spurious Level (dBm)	Failing Limit (dBm)	Remark
9kHz ~ (Fc-Test BW)	0.4800	-31.02	-20	Pass
	1.4300	-31.86		
	380.8200	-30.88		
	361.4500	-31.10		
	464.9200	-31.03		
(Fc-Test BW)~1GHz	882.5900	-29.69	-20	Pass
	501.1200	-30.41		
	752.6300	-30.05		
	489.9000	-30.55		
	644.6400	-30.53		
1GHz~2Fc	946.0200	-44.12	-20	Pass
1GHz~10Fc	1419.0000	-51.97	-20	Pass
	1419.0380	-51.97		
	1892.0500	-57.59		
	2365.0630	-57.01		
	2838.0750	-56.21		
	3311.0880	-55.35		
	3784.1000	-55.94		
	4257.1130	-56.71		
4730.1250	-57.25			

**Phase II: 479.2875 MHz, 12.5 kHz Channel Spacing, Max Power
Part22,90**

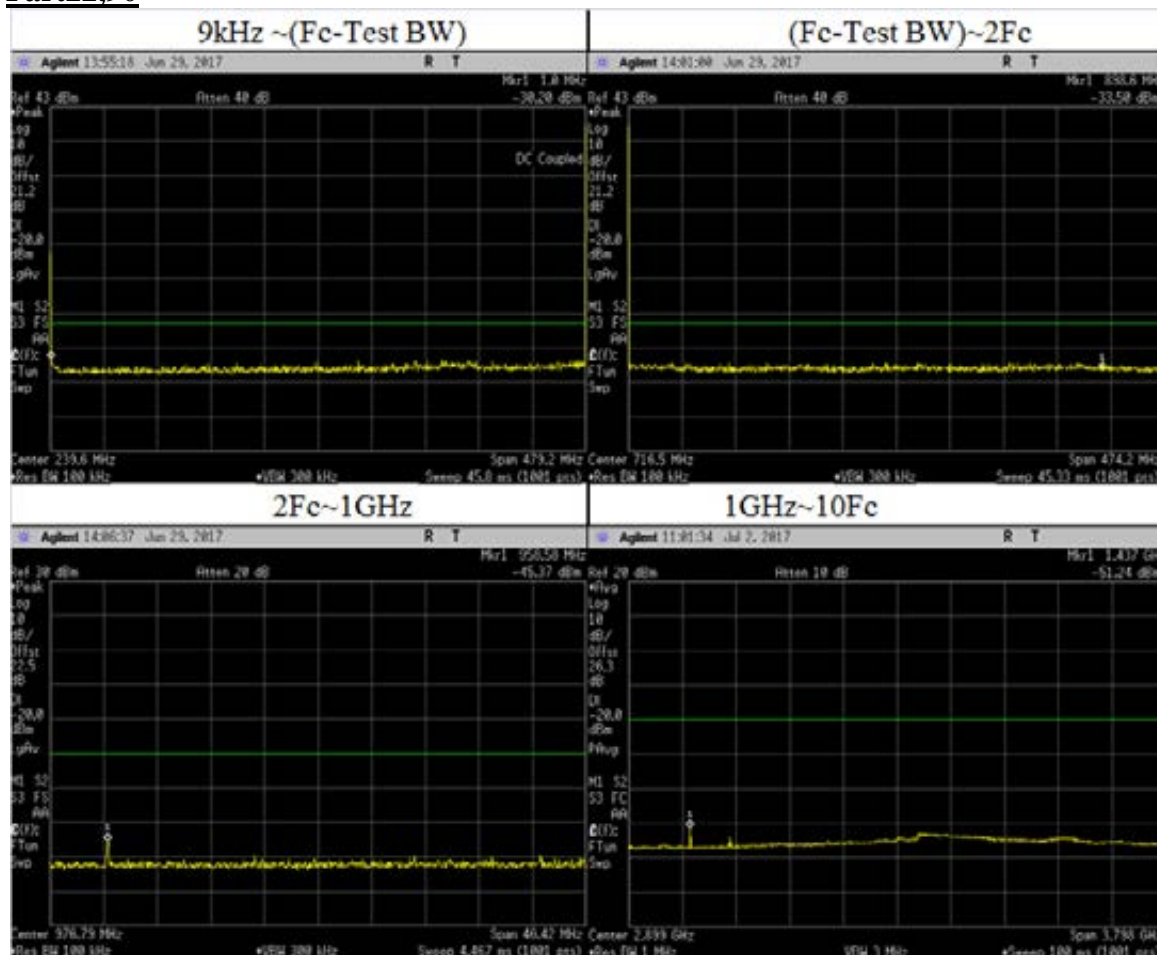

Frequency Range	Highest Spur Freq (MHz)	Spurious Level (dBm)	Failing Limit (dBm)	Remark
9kHz ~ (Fc-Test BW)	0.9700	-31.64	-20	Pass
	472.0500	-30.56		
	275.2900	-30.91		
	349.9700	-30.84		
	326.5100	-31.05		
(Fc-Test BW)~1GHz	898.6200	-29.83	-20	Pass
	707.2200	-31.05		
	834.6600	-30.86		
	734.7000	-30.94		
	530.0400	-31.36		
1GHz~2Fc	958.5800	-45.37	-20	Pass
1GHz~10Fc	1437.0000	-51.24	-20	Pass
	1437.8630	-51.24		
	1917.1500	-56.35		
	2396.4380	-55.76		
	2875.7250	-55.05		
	3355.0130	-53.69		
	3834.3000	-55.03		
	4313.5880	-55.73		
	4792.8750	-55.95		

Phase II: 467.7750 MHz, 12.5 kHz Channel Spacing, Max Power Part 80, 90 and RSS 119

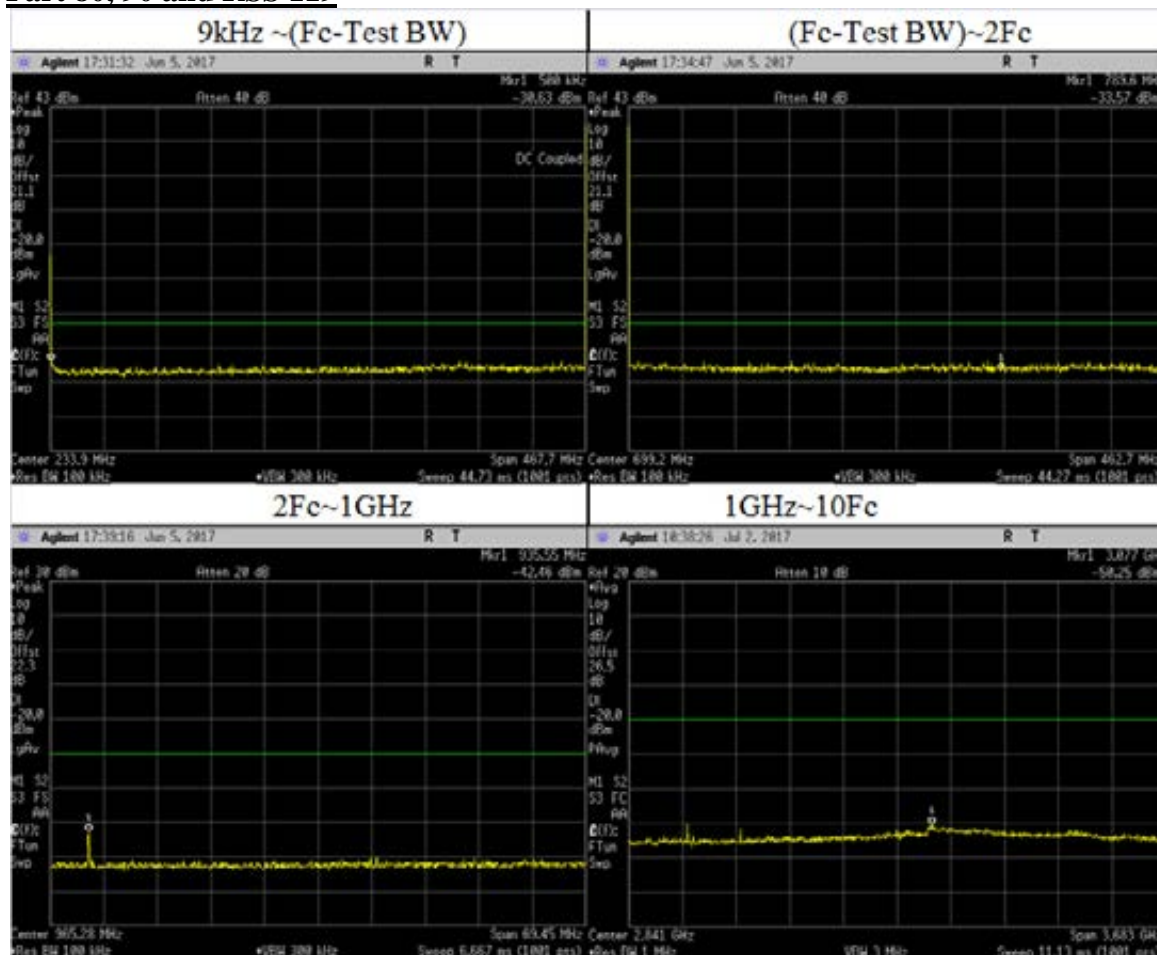

Frequency Range	Highest Spur Freq (MHz)	Spurious Level (dBm)	Failing Limit (dBm)	Remark
9kHz ~ (Fc-Test BW)	0.4800	-32.04	-20	Pass
	445.7600	-30.80		
	356.9800	-31.01		
	1.4100	-32.39		
	363.0600	-31.13		
(Fc-Test BW)~1GHz	789.5600	-30.17	-20	Pass
	777.5400	-30.12		
	608.8200	-30.55		
	476.1500	-30.79		
	884.3200	-30.37		
1GHz~2Fc	935.5500	-42.46	-20	Pass
1GHz~10Fc	3076.7120	-50.25	-20	Pass
	1403.3250	-50.13		
	1871.1000	-54.34		
	2338.8750	-54.37		
	2806.6500	-53.13		
	3274.4250	-52.71		
	3742.2000	-53.06		
	4209.9750	-53.82		
4677.7500	-54.08			

**Phase II: 467.7750 MHz, 12.5 kHz Channel Spacing, Low Power
Part 80,90 and RSS 119**

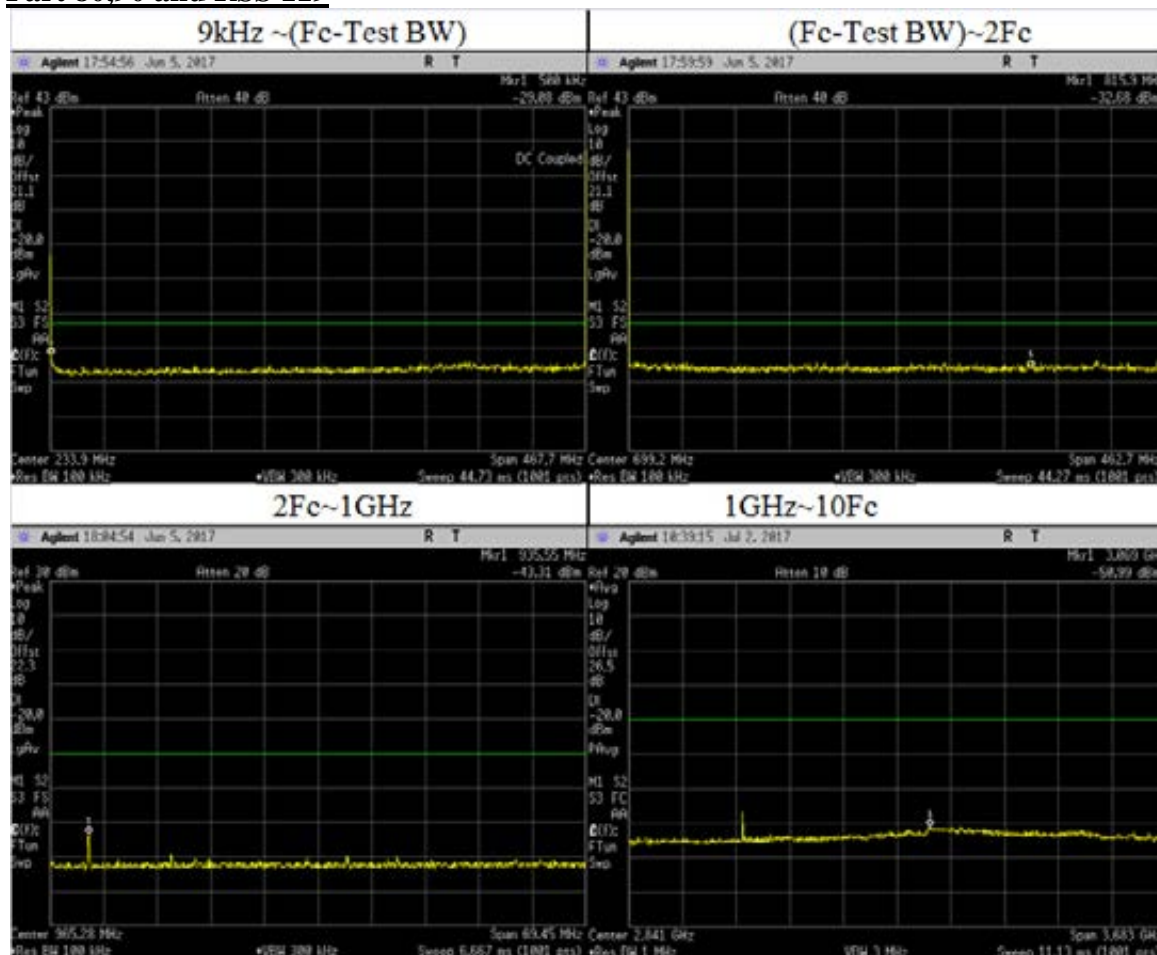

Frequency Range	Highest Spur Freq (MHz)	Spurious Level (dBm)	Failing Limit (dBm)	Remark
9kHz ~ (Fc-Test BW)	0.4800	-30.49	-20	Pass
	365.8600	-30.95		
	362.1200	-31.12		
	400.9000	-31.13		
	356.5200	-31.48		
(Fc-Test BW)~1GHz	815.9100	-30.20	-20	Pass
	924.0800	-30.25		
	871.8400	-30.33		
	656.4300	-30.85		
	472.9200	-31.09		
1GHz~2Fc	935.5500	-43.31	-20	Pass
1GHz~10Fc	3069.3460	-50.99	-20	Pass
	1403.3250	-55.54		
	1871.1000	-55.16		
	2338.8750	-54.34		
	2806.6500	-53.70		
	3274.4250	-51.74		
	3742.2000	-53.39		
	4209.9750	-53.21		
	4677.7500	-54.82		

Phase II: 511.9875 MHz, 12.5 kHz Channel Spacing, Max Power
Part 90

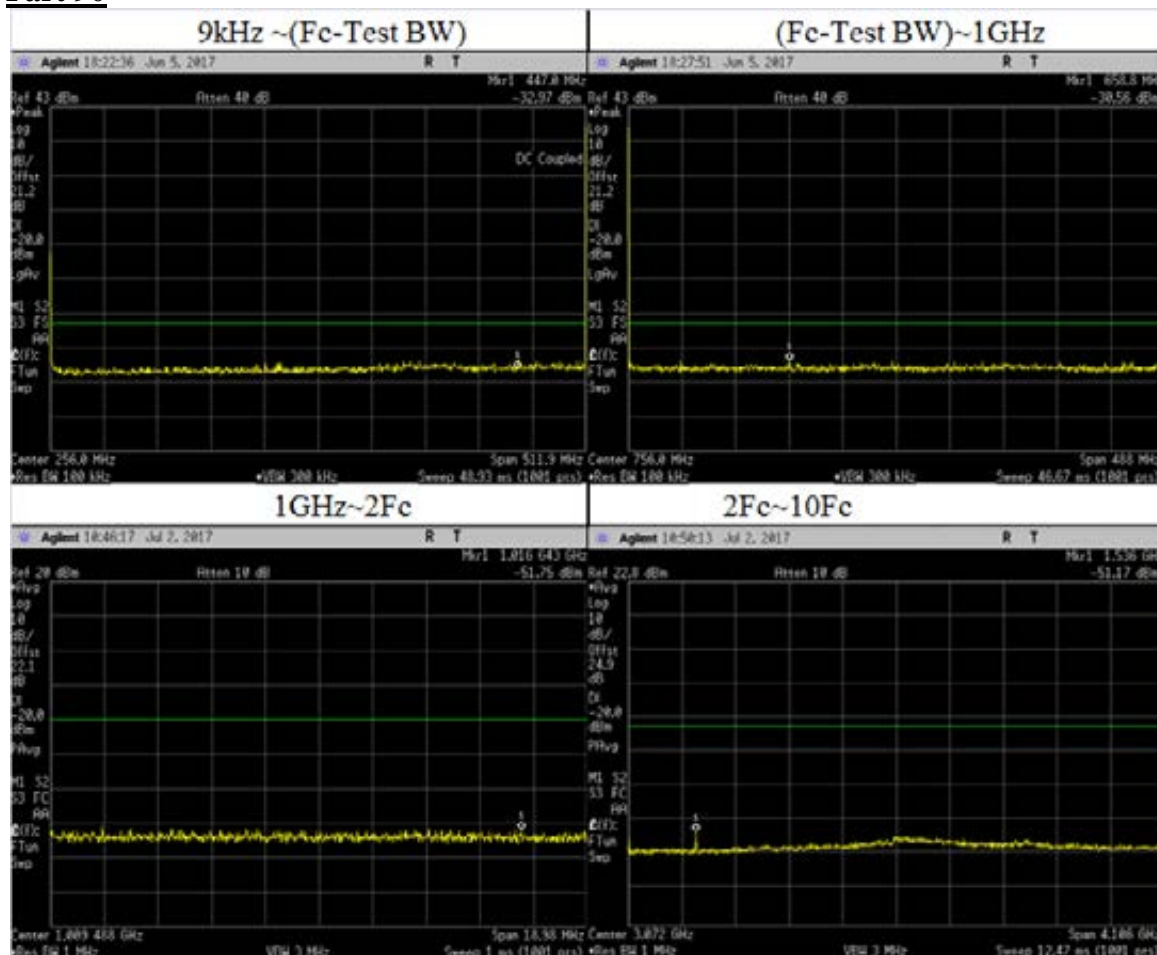

Frequency Range	Highest Spur Freq (MHz)	Spurious Level (dBm)	Failing Limit (dBm)	Remark
9kHz ~ (Fc-Test BW)	446.9800	-30.58	-20	Pass
	1.0300	-32.13		
	463.8600	-30.90		
	352.3700	-31.21		
	503.2400	-31.01		
(Fc-Test BW)~1GHz	658.7700	-30.40	-20	Pass
	752.3700	-30.48		
	559.8200	-30.97		
	735.3000	-30.62		
	961.4900	-30.54		
1GHz~2Fc	1016.6430	-51.75	-20	Pass
1GHz~10Fc	1536.3560	-51.17	-20	Pass
	1023.9750	-53.40		
	1535.9625	-50.99		
	2047.9500	-55.92		
	2559.9375	-55.33		
	3071.9250	-53.12		
	3583.9125	-54.95		
	4095.9000	-54.85		
	4607.8875	-56.31		
5119.8750	-55.91			

Phase II: 511.9875 MHz, 12.5 kHz Channel Spacing, Low Power
Part 90

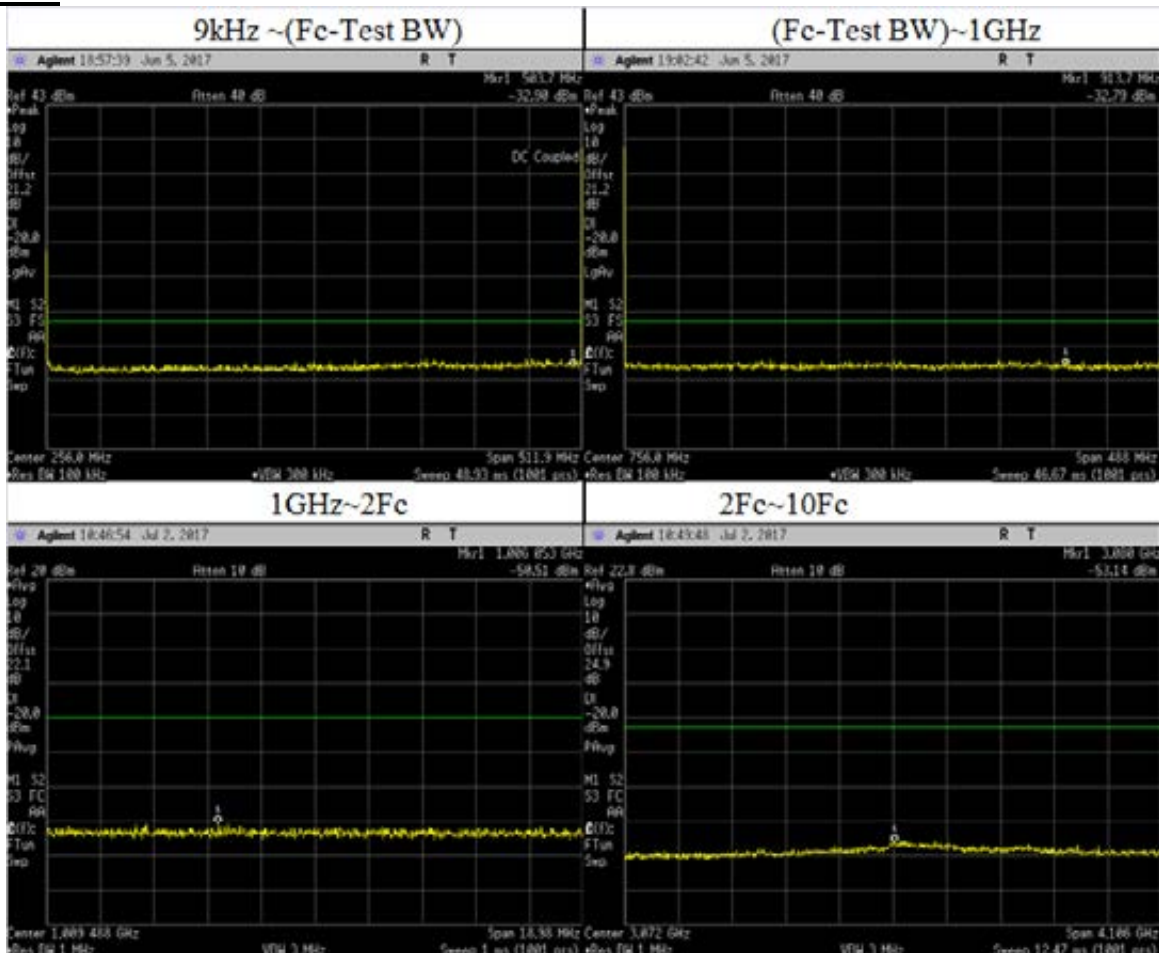

Frequency Range	Highest Spur Freq (MHz)	Spurious Level (dBm)	Failing Limit (dBm)	Remark
9kHz ~ (Fc-Test BW)	503.7500	-30.45	-20	Pass
	1.0300	-31.98		
	362.6000	-30.86		
	463.3500	-30.80		
	458.2300	-30.86		
(Fc-Test BW)~1GHz	913.7200	-30.05	-20	Pass
	999.5100	-30.34		
	888.8600	-30.60		
	851.8100	-30.66		
	645.1200	-31.14		
1GHz~2Fc	1006.0530	-50.51	-20	Pass
1GHz~10Fc	3080.0000	-53.14	-20	Pass
	1023.9750	-57.11		
	1535.9625	-56.95		
	2047.9500	-56.26		
	2559.9375	-55.76		
	3071.9250	-53.53		
	3583.9125	-54.46		
	4095.9000	-55.31		
	4607.8875	-55.51		
	5119.8750	-55.98		

**Phase II: 519.9875 MHz, 12.5 kHz Channel Spacing, Max Power
Federal Frequency(Not For FCC Review)**

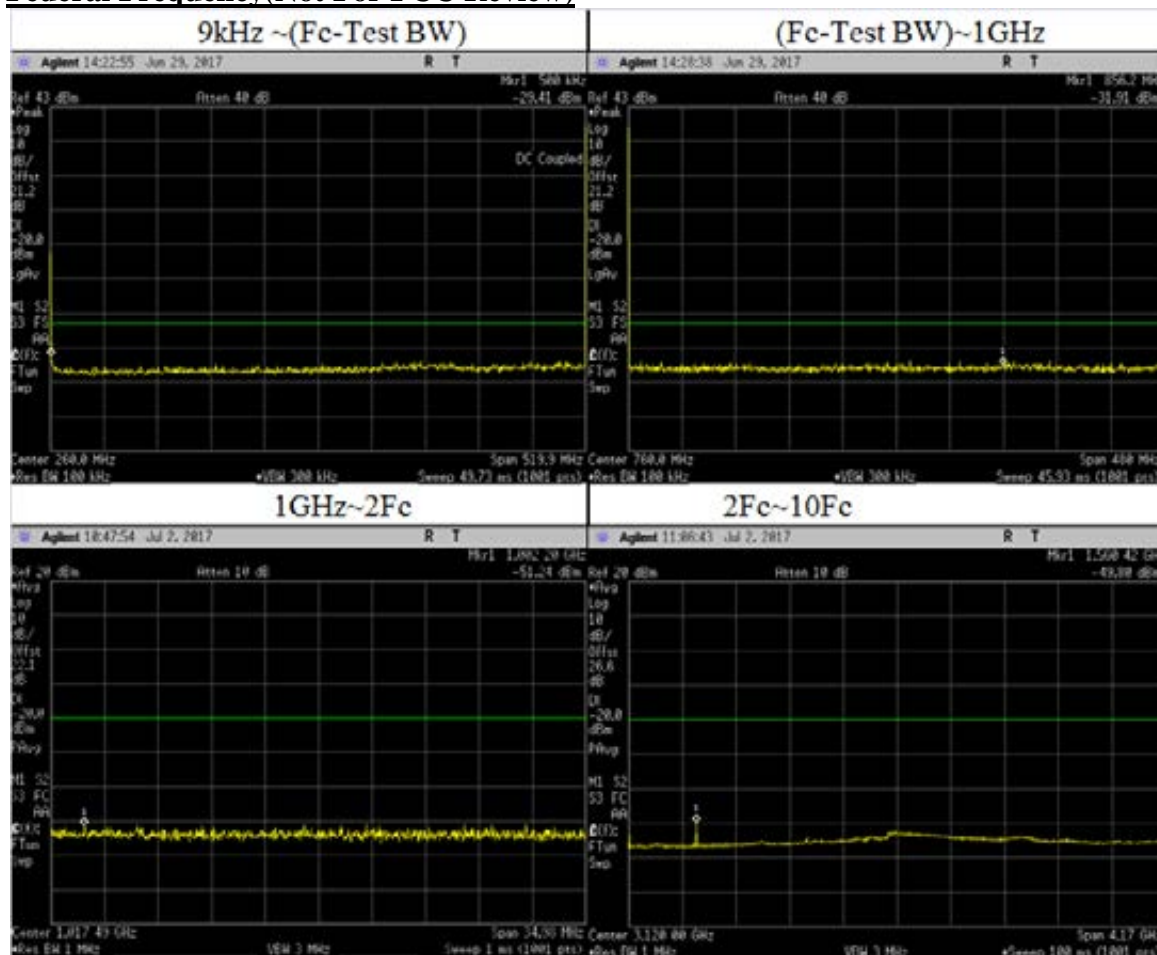

Frequency Range	Highest Spur Freq (MHz)	Spurious Level (dBm)	Failing Limit (dBm)	Remark
9kHz ~ (Fc-Test BW)	0.5300	-30.94	-20	Pass
	359.4400	-30.97		
	2.0900	-32.29		
	464.8800	-31.14		
	501.7500	-31.12		
(Fc-Test BW)~1GHz	856.1600	-29.97	-20	Pass
	772.2500	-30.09		
	896.9100	-30.30		
	864.7900	-30.39		
	816.3600	-30.69		
1GHz~2Fc	1002.2000	-51.24	-20	Pass
1GHz~10Fc	1560.4200	-49.80	-20	Pass
	1039.9750	-53.41		
	1559.9625	-49.57		
	2079.9500	-55.51		
	2599.9375	-55.27		
	3119.925	-52.73		
	3639.9125	-54.37		
	4159.9000	-54.49		
	4679.8875	-55.54		
	5199.8750	-55.03		

**Phase II: 459.1250 MHz, 12.5 kHz Channel Spacing, Max Power
RSS 119**

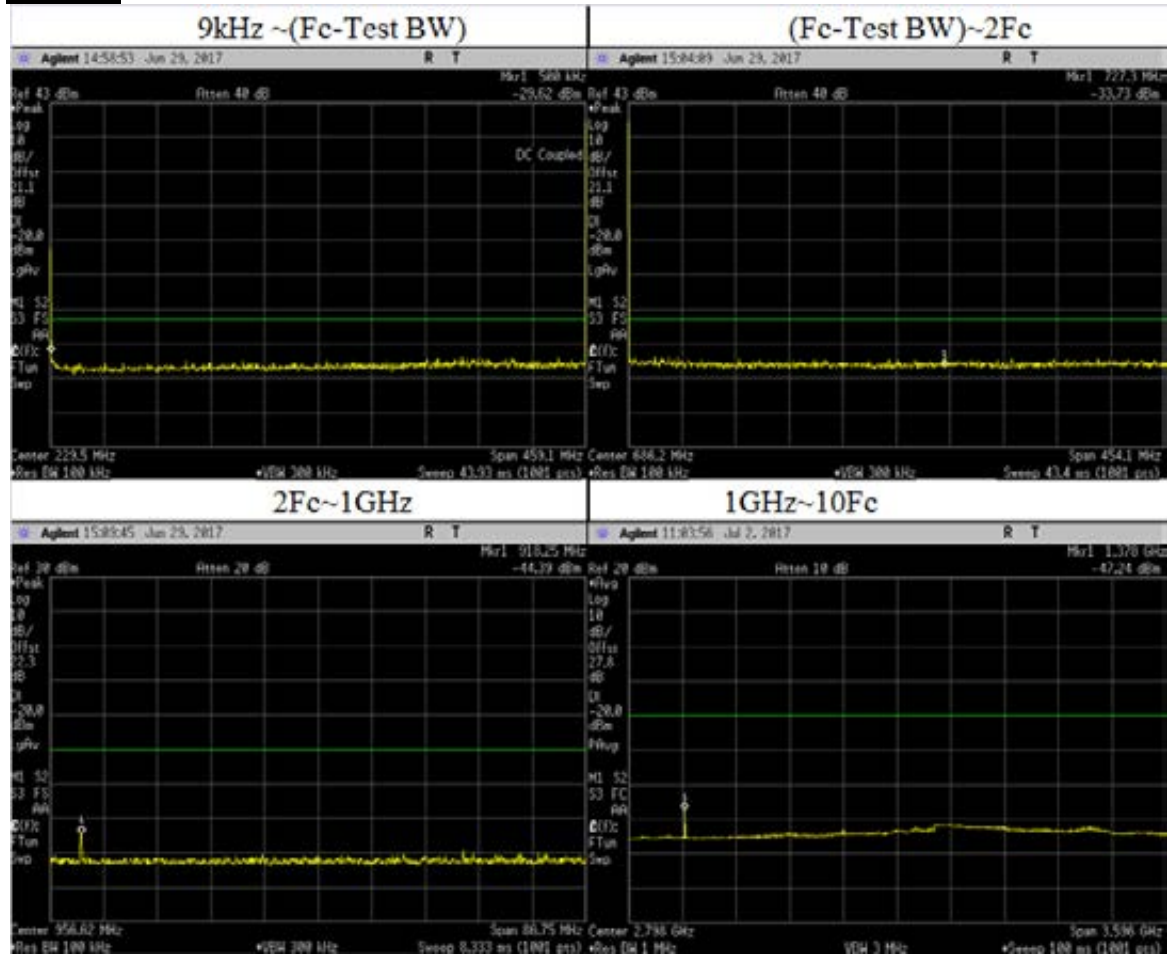

Frequency Range	Highest Spur Freq (MHz)	Spurious Level (dBm)	Failing Limit (dBm)	Remark
9kHz ~ (Fc-Test BW)	0.4700	-31.02	-20	Pass
	352.6700	-30.83		
	434.7600	-31.15		
	361.8500	-31.34		
	394.8700	-31.34		
(Fc-Test BW)~2Fc	727.2700	-30.01	-20	Pass
	481.8600	-30.89		
	464.6200	-31.04		
	493.2000	-31.00		
	500.9100	-31.07		
2Fc~1GHz	918.2500	-44.39	-20	Pass
1GHz~10Fc	1377.3750	-47.10	-20	Pass
	1836.5000	-54.84		
	2295.6250	-54.38		
	2754.7500	-53.72		
	3213.8750	-51.96		
	3673.0000	-53.15		
	4132.1250	-52.81		
	4591.2500	-54.20		

6.10.2. Test Limit

Table below summarized the power of any emission outside a licensee’s frequency block shall be attenuated below the transmitter power (P) by at least

Channel Spacing	Part 22	Part 24D	Part 74	Part 80	Part 90
12.5kHz	43 + log10(P) (-13 dBm)	43 + log10(P) (-13 dBm)	43 + log10(P) (-13 dBm)	Not Applicable	50 + log10(P) (-20 dBm)
25kHz		Not Applicable		43 + log10(P) (-13 dBm)	43 + log10(P) (-13 dBm)

6.11. Radiated Spurious Emission

6.11.1. Test Setup

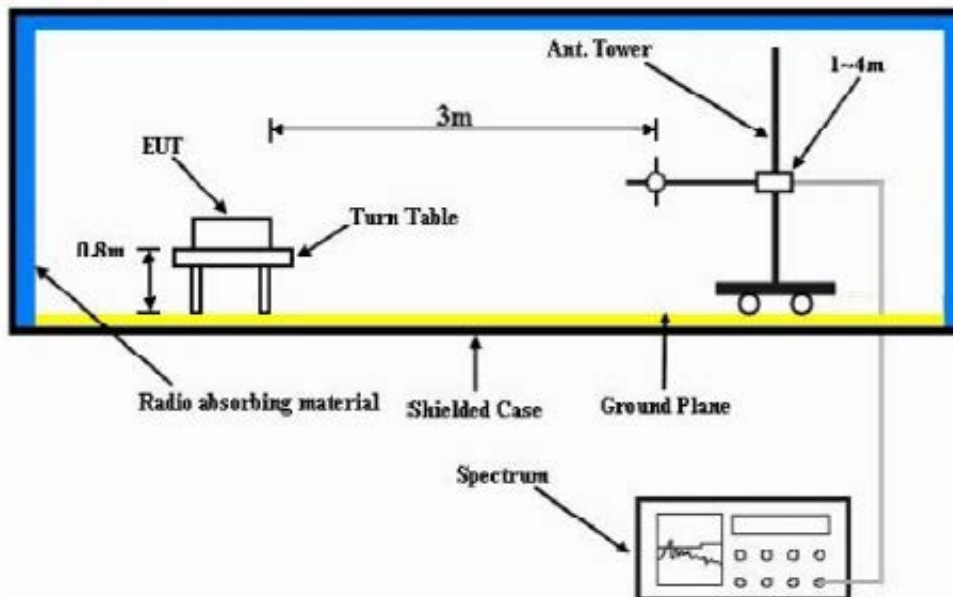

- 1) The spectrum setting for scanning Radiated Emission below 1 GHz is RBW = 100 kHz, VBW = 300 kHz and above 1 GHz is RBW = 1 MHz, VBW = 3 MHz. Detector mode is positive peak.
- 2) In the semi-anechoic chamber, setup as illustrated above the EUT placed on the 0.8m height of Turn Table, rotated the table around 360 degrees to search the maximum radiation power and receiver antenna shall be rotated vertical and horizontal polarization and moved height from 1m to 4m to find the maximum polar radiated power. The “Read Value” is the spectrum reading the maximum power value.
- 3) The substitution antenna is substituted for EUT at the same position and signals generator (S.G) export the CW signal to the substitution antenna via a TX cable. The receiver antenna shall be rotated vertical and horizontal polarization and moved height from 1m to 4m to find the maximum radiation power. Record the power level of maximum radiation power from spectrum. So, the measured substitution value = Ref level of S.G + TX cables loss – Substituted Antenna Gain.
- 4) Final Radiated Spurious Emission = “Read Value” + Measured substitution value.

6.11.2. Test Result
Not Applicable

6.11.3. Test Limit

Table below summarized the power of any emission outside a licensee’s frequency block shall be attenuated below the transmitter power (P) by at least

Channel Spacing	Part 22	Part 24D	Part 74	Part 80	Part 90
12.5kHz	43 + log10(P) (-13 dBm)	43 + log10(P) (-13 dBm)	43 + log10(P) (-13 dBm)	Not Applicable	50 + log10(P) (-20 dBm)
25kHz		Not Applicable		43 + log10(P) (-13 dBm)	

6.12. Effective Radiated Power (ERP) / GNSS (EIRP for 1559 - 1610MHz)

6.12.1. Test Setup

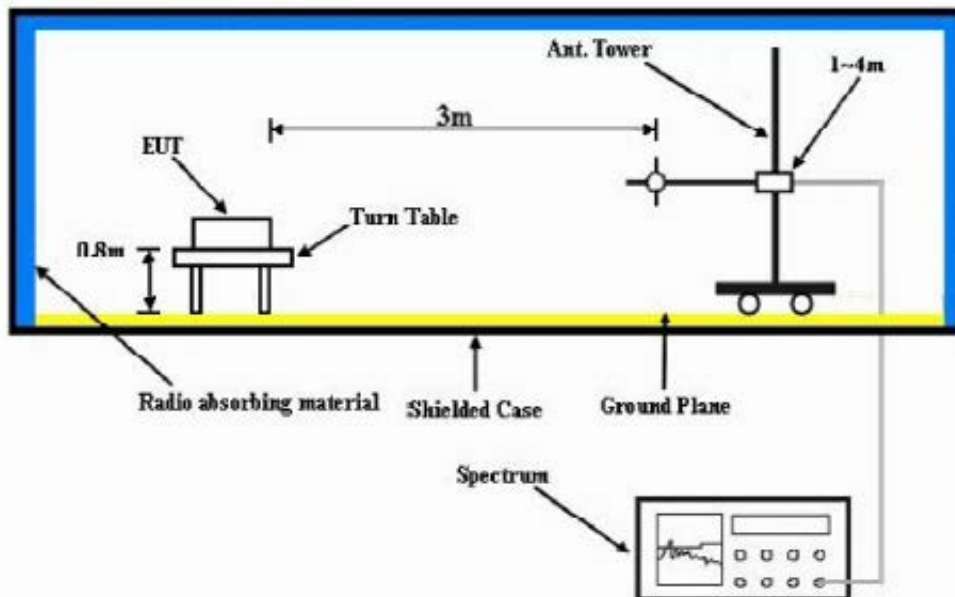

- 1) The spectrum setting for Equivalent Isotropically Radiated Power (EIRP) is RBW = 100 kHz, VBW = 300 kHz. Detector Mode is RMS.
- 2) In the semi-anechoic chamber, setup as illustrated above the EUT placed on the 0.8m height of Turn Table, rotated the table 45 degree each interval to search the maximum radiation power and receiver antenna shall be rotated vertical and horizontal polarization and moved height from 1m to 4m to find the maximum polar radiated power for each degree interval. The "Read Value" is the spectrum reading of maximum power value.
- 3) The substitution antenna is substituted for EUT at the same position and signals generator (S.G) export the CW signal to the substitution antenna via a TX cable. The receiver antenna shall be rotated vertical and horizontal polarization and moved height from 1m to 4m to find the maximum radiation power. Record the power level of maximum radiation power from spectrum. So, the Measured substitution value = Ref level of S.G + TX cables loss – Substituted Antenna Gain.
- 4) $EIRP = \text{"Read Value"} + \text{Measured substitution value} + 2.15$.

6.12.2. Test Result Not Applicable

6.12.3. Test Limit

The maximum output power of the transmitter for mobile stations is 100 watts (20 dBW). Power is given in terms of effective radiated power (ERP).

For operations in the 758-775 MHz and 788-805 MHz bands, all emissions including harmonics in the band 1559-1610 MHz shall be limited to -70 dBW/MHz equivalent isotropically radiated power (EIRP) for wideband signals, and -80 dBW EIRP for discrete emissions of less than 700 Hz bandwidth.

6.13. AC Power Line Conducted Spur Emissions

6.13.1. Test Setup

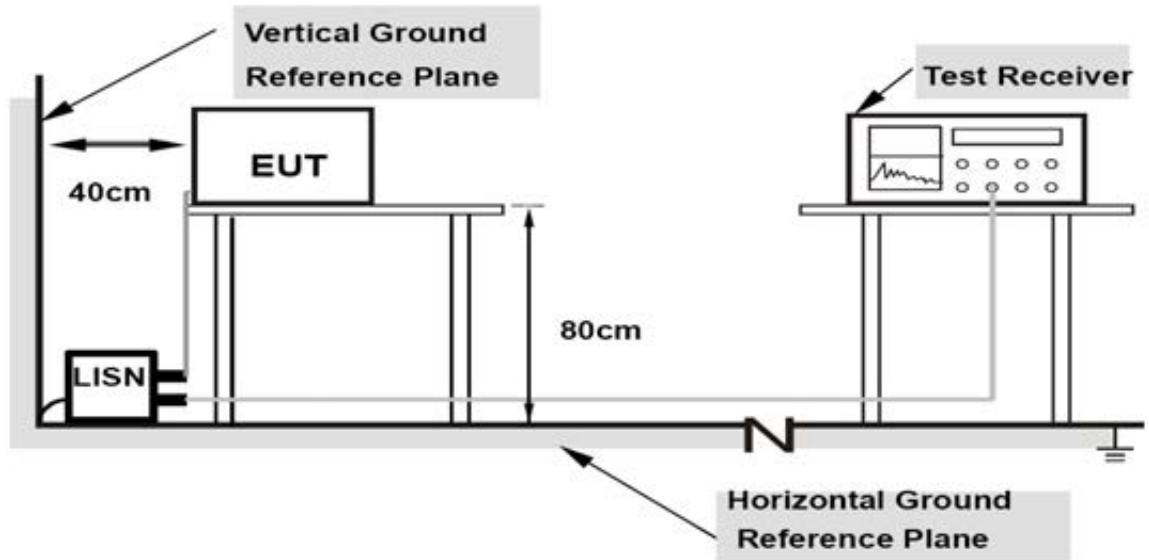

- 1) Tests were conducted for both Receive and Transmit Mode of the EUT.
- 2) The EUT was placed 0.4 meters from the conducting wall of the shielded room with EUT being connected to the power mains through a line impedance stabilization network (LISN). Other support units were connected to the power mains through another LISN. The two LISNs provide 50 ohm / 50 μ H of coupling impedance for the measuring instrument.
- 3) Both lines of the power mains connected to the EUT were checked for maximum conducted interference.
- 4) The frequency range from 150 kHz to 30 MHz was measured.

6.13.2. Test Result **Not Applicable**

6.13.3. Test Limit

For AC Power Line Conducted Test Limit can be Class A or B depends on product classification.

Limits for conducted disturbance at the mains ports of class A ITE

Frequency range MHz	Limits dB(μV)	
	Quasi-peak	Average
0,15 to 0,50	79	66
0,50 to 30	73	60
NOTE The lower limit shall apply at the transition frequency.		

Limits for conducted disturbance at the mains ports of class B ITE

Frequency range MHz	Limits dB(μV)	
	Quasi-peak	Average
0,15 to 0,50	66 to 56	56 to 46
0,50 to 5	56	46
5 to 30	60	50
NOTE 1 The lower limit shall apply at the transition frequencies.		
NOTE 2 The limit decreases linearly with the logarithm of the frequency in the range 0,15 MHz to 0,50 MHz.		