



MOTOROLA PENANG ADV. COMM. LABORATORY

Motorola Solutions Malaysia SDN BHD,
Plot 2A, Medan Bayan Lepas,
Mukim 12 S.W.D, 11900 Bayan Lepas,
Penang, Malaysia.

FCC / ISED TEST REPORT

Report Revision : Rev.D

Date/s Tested : 31-JAN-2020 - 17-FEB-2020
Report Issue Date : 19-FEB-2020
Manufacturer : Motorola Solutions Malaysia SDN BHD
Manufacturer Address : Plot 2A, Medan Bayan Lepas, Mukim 12 SWD,
11900 Bayan Lepas, Penang, Malaysia
Requestor : MAHENDRAN KIRUBAKARAN
Product Type : Portable
Product Version : CLP1080e
Model Number : CLU1080BHLCA
Frequency Band : 450-470 MHz
Firmware Version : D01.16.04
Rated / Max RF Output Power : 1Watt /1.35Watts
Applicant Name : Motorola Solutions Inc
ISED Registrations : MY0001
FCC Registrations : 461337



The equipment was tested accordance to the requirement listed below:

(LMR)
FCC 47 CFR Part 2/ 90
ISED RSS- Gen Issue 5 / 119 Issue 12
PASS

This report shall not be reproduced without written approval from an officially designated representative of the Motorola Penang Adv. Comm. Laboratory. The results and statements contained in this report pertain only to the device(s) evaluated.

Prepared By:

AARON GOH TONG WEN
Test Personnel

Approved Signatory:

VINCENT FOONG CHUEN KIT
Deputy Technical Manager

Table of Contents

Report Revision History	3
1.0 General Information.....	4
2.0 Summary of Test Results.....	5
3.0 Measurement Uncertainty.....	6
4.0 Equipment List.....	7
5.0 Test Condition.....	10
5.1. Transmitter Test Conditions	10
6.0 Transmitter Test Parameters	11
6.1. RF Output Power	11
6.1.1. Test Setup.....	11
6.1.2. Test Result	11
6.2. Frequency Stability	12
6.2.1. Test Setup.....	12
6.2.2. Test Result	13
6.2.3. Test Limit.....	14
6.3. Audio Frequency Response	15
6.3.1. Test Setup.....	15
6.3.2. Test Result	16
6.3.3. Test Limit.....	18
6.4. Audio Low Pass Filter Response	19
6.4.1. Test Setup.....	19
6.4.2. Test Result	20
6.4.3. Test Limit.....	22
6.5. Modulation Limiting.....	23
6.5.1. Test Setup.....	23
6.5.2. Test Result	24
6.5.3. Test Limit.....	25
6.6. Occupied Bandwidth.....	26
6.6.1. Test Setup (Analog)	26
6.6.2. Test Result (Analog).....	28
6.6.3. Test Setup (Digital).....	30
6.6.4. Test Result (Digital).....	30
6.6.5. Test Limit.....	30
6.7. Band Edge Conducted Spurious Emission (Part 22)	31
6.7.1. Test Setup (Analog)	31
6.7.2. Test Result (Analog).....	31
6.7.3. Test Setup (Digital).....	32
6.7.4. Test Result (Digital).....	32
6.7.5. Test Limit.....	32
6.8. Transient Frequency Behavior.....	33
6.8.1. Test Setup.....	33
6.8.2. Test Result	34
6.8.3. Test Limit.....	36

6.9. Adjacent Channel Power..... 37

6.9.1. Test Setup (Analog) 37

6.9.2. Test Result 37

6.9.3. Test Setup (Digital)..... 38

6.9.4. Test Result 38

6.9.5. Test Limit..... 39

6.10. Conducted Spurious Emission 41

6.10.1. Test Setup..... 41

6.10.2. Test Result (Analog)..... 42

6.10.3. Test Result (Digital)..... 50

6.10.4. Test Limit..... 50

6.11. Radiated Spurious Emission 51

6.11.1. Test Setup..... 51

6.11.2. Test Result (Analog)..... 52

6.11.3. Test Result (Digital)..... 62

6.11.4. Test Limit..... 62

6.12. Effective Radiated Power (ERP) 63

6.12.1. Test Setup..... 63

6.12.2. Test Result 64

6.12.3. Test Limit..... 64

6.13. GNSS (EIRP for 1559 - 1610MHz)..... 65

6.13.1. Test Setup..... 65

6.13.1. Test Result 66

6.13.2. Test Limit..... 66

Report Revision History

Revision History	Description	Date	Originator
Rev. A	Initial Report	18-FEB-2020	AARON GOH
Rev. B	Removed redundant data in model number	19-MAR-2020	Vincent Foong
Rev. C	Fixed formatting issues and RSS Issue dates	24-MAR-2020	Vincent Foong
Rev. D	Added Carson’s rule calculation	2-APR-2020	Vincent Foong

1.0 General Information

EUT Description:

Technologies	Land Mobile Radio (LMR)
Modulation Type	Analog

The EUT contains following accessory devices and data cable:

Item	Brand	Model or P/N
Body Worn	MOTOROLA	PMLN8064A
Audio Accy (PTT)	MOTOROLA	PMLN8077A (PMLN8077A-CF1)
Battery	MOTOROLA	HKNN4013A (With EEPROM)

General Description of Applied Standards

The EUT is a RF Product. According to the specifications of the manufacturer, the EUT is to comply with the requirements of the following standards:

ANSI C63.4-2014

ANSI C63.26-2015

No modifications were done to the UUT to facilitate the tests in this report.

Deviation from standard

Not applicable as no deviation from standard test method

2.0 Summary of Test Results

FCC General Rules Part (47CFR)	ISED General Rules Part	Test Item	Result	Remarks	Serial number tested
2.1046,90.541(700MHz)	RSS-119	RF Power Output	Pass	-	0095WA0309 0095WA0306
2.1055,90.213	RSS-119	Frequency Stability	Pass	-	0095WA0309 0095WA0306
2.1047	RSS-119	Audio Frequency Response	Pass	-	0095WA0309 0095WA0306
2.1047	RSS-119	Audio Low Pass Filter Response	Pass	-	0095WA0309 0095WA0306
2.1047	RSS-119	Modulation limiting	Pass	-	0095WA0309 0095WA0306
2.1049,90.210	RSS-119	Occupied Bandwidth	Pass	16K0F3E- 14.8370kHz 11K0F3E- 5.6005kHz	0095WA0309 0095WA0306
-	-	Band Edge Conducted Spurious Emission	NA	-	-
90.214	RSS-119	Transient Frequency Behavior	Pass	-	0095WA0309 0095WA0306
-	-	Adjacent Channel Power	NA	-	-
90.210	RSS-119	Conducted Spurious Emissions	Pass	No spur detected (noise floor)	0095WA0309 0095WA0306
90	RSS-119	Radiated Spurious Emission	Pass	Highest Spur Level- -48.18dBm	0095WA0298 0095WA0304
-	-	GNSS (EIRP for 1559 – 1610MHz)	NA	-	-
-	-	Effective Radiated Power (ERP)	NA	-	-

NA → Not Applicable

3.0 Measurement Uncertainty

Measurement	Frequency	Expanded Uncertainty (k=1.96) (\pmdB)
AC Power Line Conducted Spurious Emission	150KHz ~ 30MHz	3.43
Radiated Emissions up to 1 GHz	30MHz ~ 200MHz	4.03
	200MHz ~ 1000MHz	4.03
Radiated Emissions above 1 GHz	1GHz ~ 18GHz	4.03
	18GHz ~ 25GHz	4.03

4.0 Equipment List

FCC Analog ATE#1: (SW version: 2.4.5 & FCC Frequency Stability 1.0.3 rev.)

Description	Model	Serial Number	Calibration Date	Calibration Due Date
AUDIO ANALYZER	8903B	3729A17612	15-Nov-17	15-Nov-20
SIGNAL GENERATOR	2042	203002/956	20-Aug-19	20-Aug-20
MODULATION ANALYZER	8901B	3538A5696	4-Apr-19	4-Apr-20
DSA Dynamic Signal Analyzer	36570A	MY42506790	4-Apr-19	4-Apr-20
POWER SENSOR	E4412A	MY41502652	31-Jul-19	31-Jul-20
POWER METER	E4416A	GB41293747	19-Nov-18	19-Nov-20
POWER SUPPLY	6623A	2916A01562	31-Mar-19	31-Mar-20
CHAMBER	SH-641	92009188	29-Mar-19	29-Mar-20
N to N RF Cable # 1	M17/128-RG400	NA	NA	NA
BNC to N RF Cable # 1	RG 58	NA	NA	NA
BNC to BNC RF Cable # 1	RG 58	NA	NA	NA
BNC to BNC RF Cable # 2	RG 58	NA	NA	NA
BNC to BNC RF Cable # 3	RG 58	NA	NA	NA
BNC to BNC RF Cable # 4	RG 58	NA	NA	NA
BNC to BNC RF Cable # 5	RG 58	NA	NA	NA
BNC to BNC RF Cable # 6	RG 58	NA	NA	NA
BNC to BNC RF Cable # 7	RG 58	NA	NA	NA
N to SMA RF Cable # 1	RG 58	NA	NA	NA
N to SMA RF Cable # 2	RG 58	NA	NA	NA
N to SMA RF Cable # 3	RG 58	NA	NA	NA
Aeroflex Attenuator 30dB	49-30-34-LIM	NA	NA	NA

FCC Transient ATE #1: (SW version: FCC Transient ATE_R1.1.2)

Description	Model	Serial Number	Calibration Date	Calibration Due Date
POWER SUPPLY	6031A	2430A00146	5-Apr-19	5-Apr-20
POWER SENSOR	E4412A	MY41498918	31-Jul-19	31-Jul-20
POWER METER	E4416A	GB41293866	26-Feb-19	26-Feb-21
ATTENUATORS/SWITCH DRIVER	11713A	2508A10141	CNR	CNR
STEP ATTENUATOR/11dB	8494G	MY42143870	17-May-19	17-May-20
STEP ATTENUATOR/110dB	8496G	MY42143622	17-May-19	17-May-20
OSCILLOSCOPE	MSO8104A	MY45002372	17-Jun-19	17-Jun-20
AUDIO ANALYZER	8903B	3011A08952	5-Jul-19	5-Jul-20
AUDIO ANALYZER	8903B	3729A17409	4-Jul-19	4-Jul-20
MODULATION ANALYZER	8901B	3226A04052	3-Apr-19	3-Apr-20
SIGNAL GENERATOR	8657B	3427U06025	5-Apr-19	5-Apr-20
SPECTRUM ANALYZER	E4440A	MY48250517	1-Aug-19	1-Aug-20
N to N RF Cable # 1	SF126/11N/11N	NA	NA	NA
N to N RF Cable # 2	M17/128-RG400	NA	NA	NA
N to N RF Cable # 3	M17/128-RG400	NA	NA	NA
N to N RF Cable # 4	M17/128-RG400	NA	NA	NA
N to N RF Cable # 5	M17/128-RG400	NA	NA	NA
N to N RF Cable # 6	M17/128-RG400	NA	NA	NA
N to N RF Cable # 7	M17/128-RG400	NA	NA	NA
N to N RF Cable # 8	M17/128-RG400	NA	NA	NA
N to N RF Cable # 9	M17/128-RG400	NA	NA	NA
BNC to BNC RF Cable # 1	RG 58	NA	NA	NA
BNC to BNC RF Cable # 2	RG 58	NA	NA	NA
BNC to BNC RF Cable # 3	RG 58	NA	NA	NA
BNC to BNC RF Cable # 4	RG 58	NA	NA	NA
BNC to BNC RF Cable # 5	RG 58	NA	NA	NA
BNC to BNC RF Cable # 6	RG 58	NA	NA	NA
BNC to N RF Cable # 1	RG 58	NA	NA	NA
Aeroflex Attenuator 10dB	49-10-43-LIM	NA	NA	NA
Aeroflex Attenuator 10dB	33-10-34-LIM	NA	NA	NA
SWITCH CONTROL UNIT	3488A	2719A36210	CNR	CNR

CONDUCTED SPUR EMISSION ATE # 1 (SW version: Conducted Spur ATE Rev1.23.02)

Description	Model	Serial Number	Calibration Date	Calibration Due Date
SWITCH CONTROL UNIT	3488A	2719A32735	CNR	CNR
PSA Series Spectrum Analyzer	E4445A	MY46181732	12-Mar-19	12-Mar-21
POWER SUPPLY	6032A	2723A02219	2-Jul-19	2-Jul-20
HIGH PASS FILTER SWITCH BOX	-	CS001	4-Jul-19	4-Jul-20
N to N RF Cable # 1	SF126/11N/11N	NA	NA	NA
N to N RF Cable # 2	SF126/11N/11N	NA	NA	NA
BNC to BNC RF Cable # 1	RG 58	NA	NA	NA
Aeroflex Attenuator 30dB	49-30-43-LIM	NA	NA	NA
Aeroflex Attenuator 10dB	33-10-34-LIM	NA	NA	NA

Radiated Emission Station

Description	Model	Serial Number	Calibration Date	Calibration Due Date
DRG HORN FREQ.	SAS-571	720	21-Mar-19	21-Mar-21
DRG HORN FREQ.	SAS-571	1143	14-Feb-19	14-Feb-21
POWER SUPPLY (0-60V / 0-50A, 1000W)	6032A	MY41001736	25-May-19	25-May-20
SIGNAL GENERATOR	SMB 100A	181117	8-Nov-18	8-Nov-21
EMI TEST RECEIVER	ESW44	101750	24-Jul-19	24-Jul-20
EMI TEST RECEIVER	ESIB26	100017	19-Jul-19	19-Jul-20
5m Semi-anechoic Chamber	S800-HX	J2308	No Cal. Req'd	No Cal. Req'd
BILOG ANTENNA	CBL6112D	30991	5-Aug-19	5-Aug-20
BILOG ANTENNA	CBL6112B	2964	16-Feb-18	16-Feb-20
DATA LOGGER	SDL500	A.016800	19-Mar-19	18-Mar-20
SYSTEM CONTROLLER	SC104V	050806-1	No Cal. Req'd	No Cal. Req'd
TURNTABLE FLUSH MOUNT 2M	FM2011	NA	No Cal. Req'd	No Cal. Req'd
ANTENNA POSITIONING TOWER	TLT2	NA	No Cal. Req'd	No Cal. Req'd
BROAD-BAND HORN ANTENNA	BBHA9170	BBHA9170143	23-Jun-19	23-Jun-20
18 - 40GHz PREAMPLIFIER	Miteq Hi Gain Sucoflex	1	No Cal. Req'd	No Cal. Req'd
PREAMPLIFIER	PAM-0118	269	24-May-19	24-May-20
LOOP ANTENNA	6502	208416	5-Sep-19	5-Sep-20
Test Software	EMC FCC IC Bluetooth RE Test			
Version	EMC FCC RE v1.6.1			

5.0 Test Condition

5.1. Transmitter Test Conditions

Test Item, (Channel Spacing)	Power (W)	Modulation	Test Frequency (MHz)	Tested By	Environmental Conditions
RF Output Power	Low & Max	Analog	450.025,459.125, 467.775,469.9875	AARON GOH	29.1°C, 43.6%RH
Frequency Stability	Max	Analog	467.775	AARON GOH	25.1°C, 54.3%RH, 60.3°C, 50%RH, -30.1°C, 50%RH
Audio Frequency Response (12.5kHz / 25kHz)	Max	Analog	467.775,459.125	AARON GOH	25.1°C,54.3%RH
Audio Low Pass Filter Response (12.5kHz / 25kHz)	Max	Analog	467.775,459.125	AARON GOH	25.1°C,54.3%RH
Modulation limiting (12.5kHz / 25kHz)	Max	Analog	467.775,459.125	AARON GOH	25.1°C,54.3%RH
Occupied Bandwidth (12.5kHz / 20kHz / 25kHz)	Max	Analog	450.025,467.775, 450.025	AARON GOH	29.1°C, 43.6%RH
Band Edge Conducted Spurious Emissions (Part 22) (12.5kHz / 20kHz / 25kHz)	Max	Analog	NA	NA	29.1°C, 43.6%RH
Transient Frequency Behavior (UHF & VHF Band) (12.5kHz / 25kHz)	Max	Analog	467.775	AARON GOH	29.1°C, 43.6%RH
Adjacent Channel Power (700MHz Band) (12.5kHz / 25kHz)	Max	Analog	NA	NA	NA
Conducted Spurious Emissions- (12.5kHz / 25kHz)	Low / Max	Analog	450.025,459.125, 469.9875	AARON GOH	29.1°C, 43.6%RH
Radiated Spurious Emission (12.5kHz / 25kHz)	Low / Max	Analog	450.025,459.125 ,469.9875	Nazrin&Qawiman	23.2°C,69.3%RH
GNSS (EIRP for 1559 - 1610MHz) (12.5kHz / 25kHz)	Max	Analog	NA	NA	NA
Effective Radiated Power (ERP) (12.5kHz / 25kHz)	Max	Analog	NA	NA	NA

NA → Not Applicable

6.0 Transmitter Test Parameters

6.1. RF Output Power

6.1.1. Test Setup

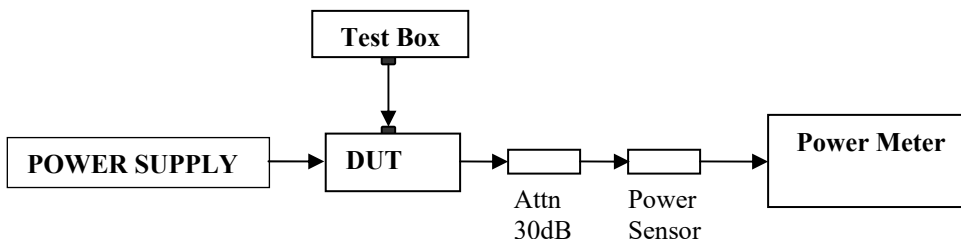

- 1) The DUT transmitter connected to Power Meter using the 30 dB attenuator and power sensor with above setup.
- 2) Path loss for the measurement included.
- 3) All the measurement was done at low, mid, high frequency for each band.
- 4) Record the power into the test report.

6.1.2. Test Result

Temperature	25°C				Remarks
Voltage (V)	4.2V				
Frequency (MHz)	Low Power (W)	Current (A)	Max Power (W)	Current (A)	
450.0125	0.54	0.54	1.31	0.93	
450.0250	0.534	0.54	1.31	0.93	
459.1250	0.486	0.51	1.31	0.96	
467.7750	0.509	0.51	1.25	1.23	
469.9375	0.496	0.54	1.29	1.05	
469.9875	0.493	0.54	1.35	1.05	

6.2. Frequency Stability

6.2.1. Test Setup

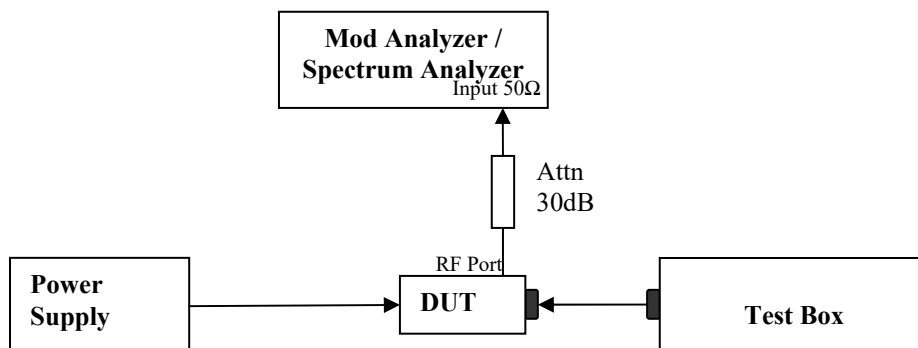

- 1) The DUT transmitter output port was connected to Modulation / Spectrum Analyzer.
- 2) Path loss for the measurement included.
- 3) Transmit the DUT and record the freq in MCF_{MHz} .
- 4) Test in 2 conditions:
 - Temperature: The frequency of the transmitter was measured from $-30^{\circ}C$ to $50^{\circ}C$.
 - Supply Voltage:
 - Mobile: The frequency of the transmitter was measured from 85% to 115% of the nominal operating input voltage.
 - Portable: The frequency of the transmitter was measured from nominal $\pm x\%$ as specified by the manufacturer
- 5) Calculate the ppm frequency error by the following:

$$ppm\ error = \left(\frac{MCF_{MHz}}{ACF_{MHz}} - 1 \right) * 10^6$$

Where: MCF_{MHz} is the Measured Carrier Frequency in MHz
 ACF_{MHz} is the Assigned Carrier Frequency in MHz

6.2.2. Test Result

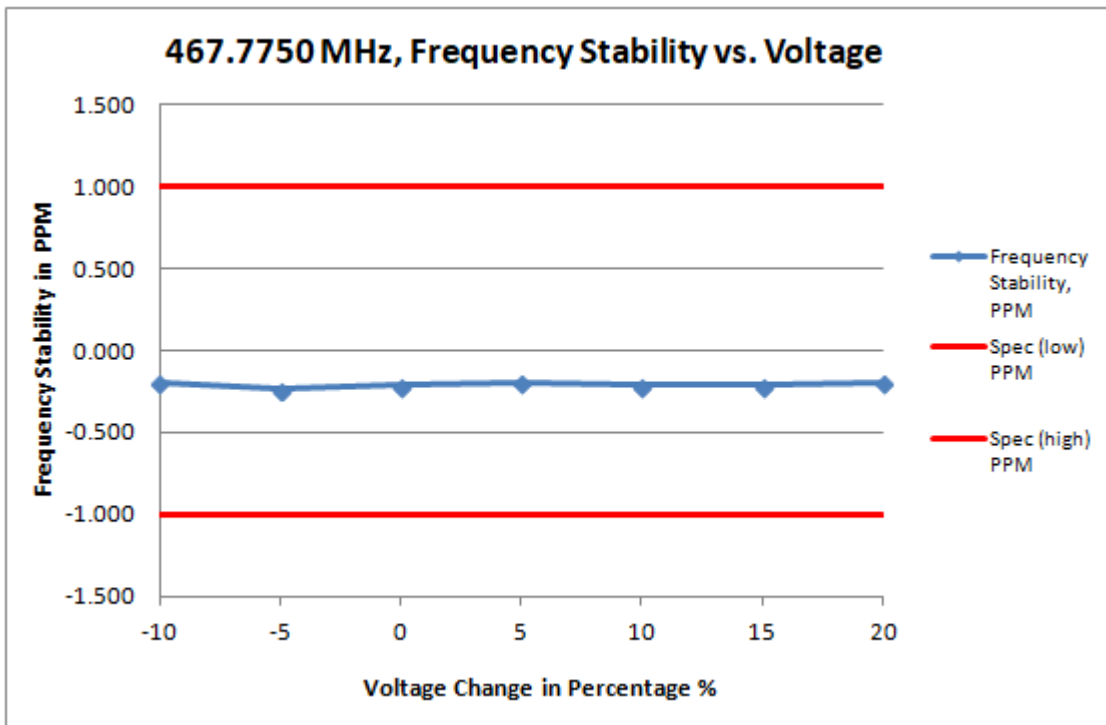

(i) Frequency Stability VS Voltage

Frequency / Channel Spacing	467.7750 MHz / 12.5 kHz				
Temperature, °C	25				
Voltage %	Voltage, V	Frequency, MHz	Frequency Stability, PPM	Spec (low) PPM	Spec (high) PPM
-10	3.330	467.774910	-0.192	-1.000	1.000
-5	3.515	467.774890	-0.235	-1.000	1.000
0	3.700	467.774900	-0.214	-1.000	1.000
5	3.885	467.774910	-0.192	-1.000	1.000
10	4.070	467.774900	-0.214	-1.000	1.000
15	4.255	467.774900	-0.214	-1.000	1.000
20	4.440	467.774910	-0.192	-1.000	1.000

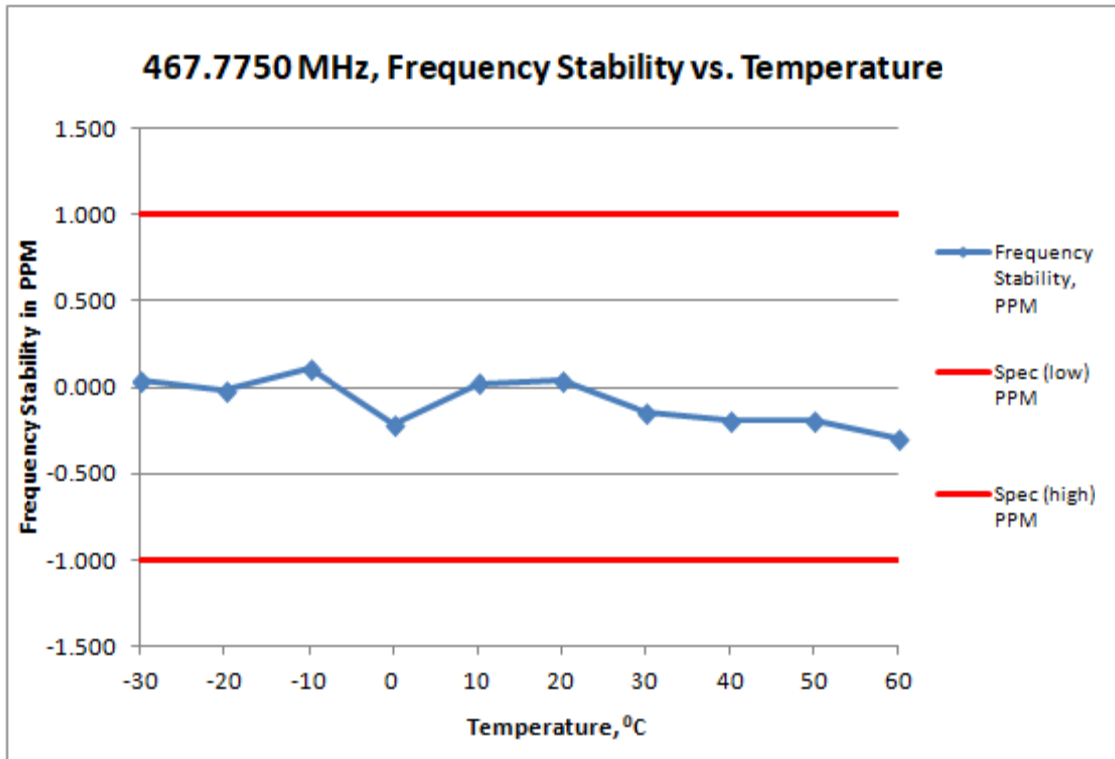

(ii) Frequency Stability VS temperature

Frequency / Channel Spacing	467.7750 MHz / 12.5 kHz			
Voltage, V	3.7			
Temperature, °C	Frequency, MHz	Frequency Stability, PPM	Spec (low) PPM	Spec (high) PPM
-30	467.775020	0.043	-1.000	1.000
-20	467.774990	-0.021	-1.000	1.000
-10	467.775050	0.107	-1.000	1.000
0	467.774900	-0.214	-1.000	1.000
10	467.775010	0.021	-1.000	1.000
20	467.775020	0.043	-1.000	1.000
30	467.774930	-0.150	-1.000	1.000
40	467.774910	-0.192	-1.000	1.000
50	467.774910	-0.192	-1.000	1.000
60	467.774860	-0.299	-1.000	1.000

6.2.3. Test Limit

As per manufacturer declared spec +/- 1.0ppm

6.3. Audio Frequency Response

6.3.1. Test Setup

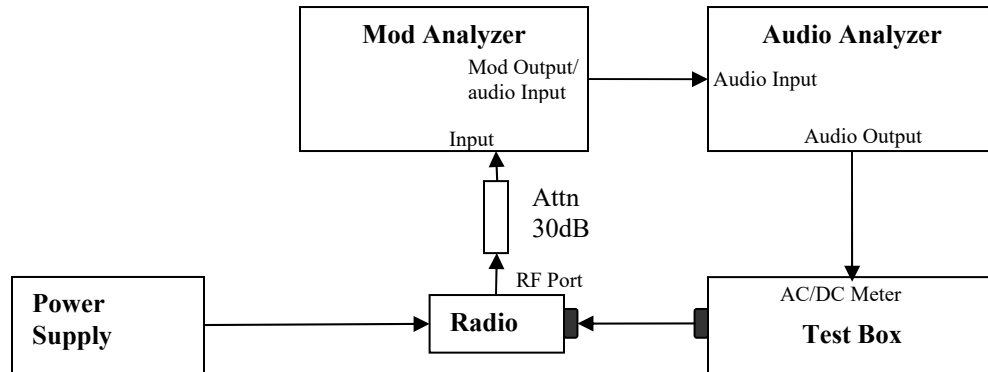

- 1) The DUT transmitter output port was connected to Modulation Analyzer.
- 2) Path loss for the measurement included.
- 3) Set the audio bandwidth filter to 15 kHz and 50 kHz.
- 4) Transmit the radio and set the audio analyzer to 1 kHz audio frequency and 20% of the Full rated system deviation.
- 5) On audio analyzer, set the rated level as reference to zero.
- 6) Vary the audio frequency from 300 Hz to 3 kHz. Record the change in dB on the audio analyzer.

6.3.2. Test Result

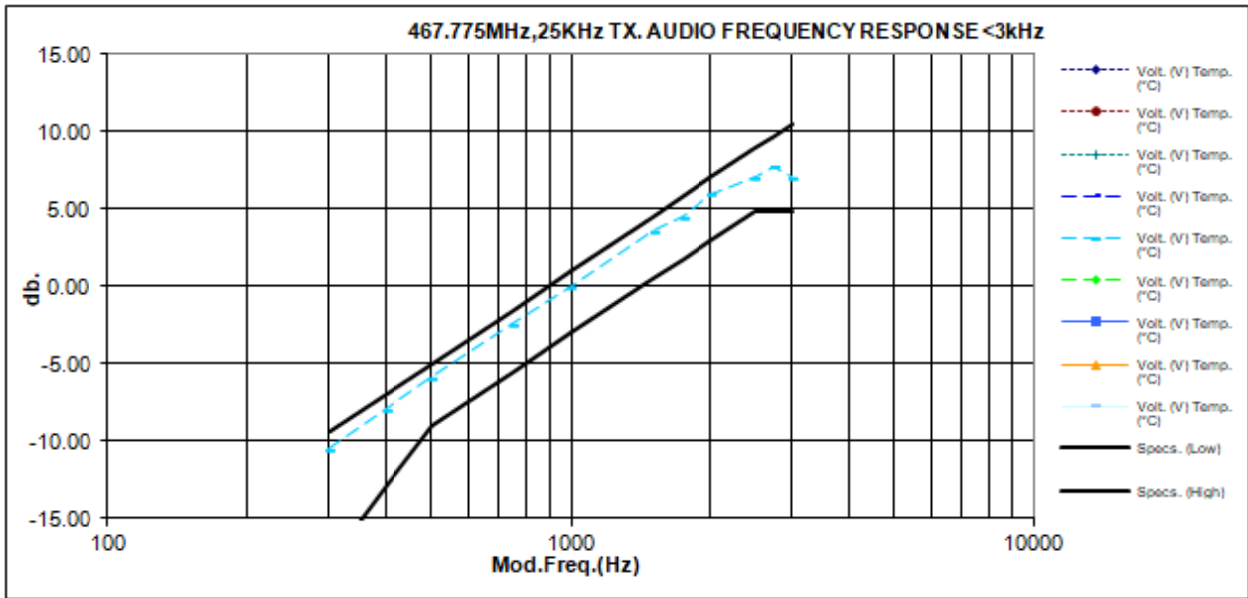

Not for FCC Review

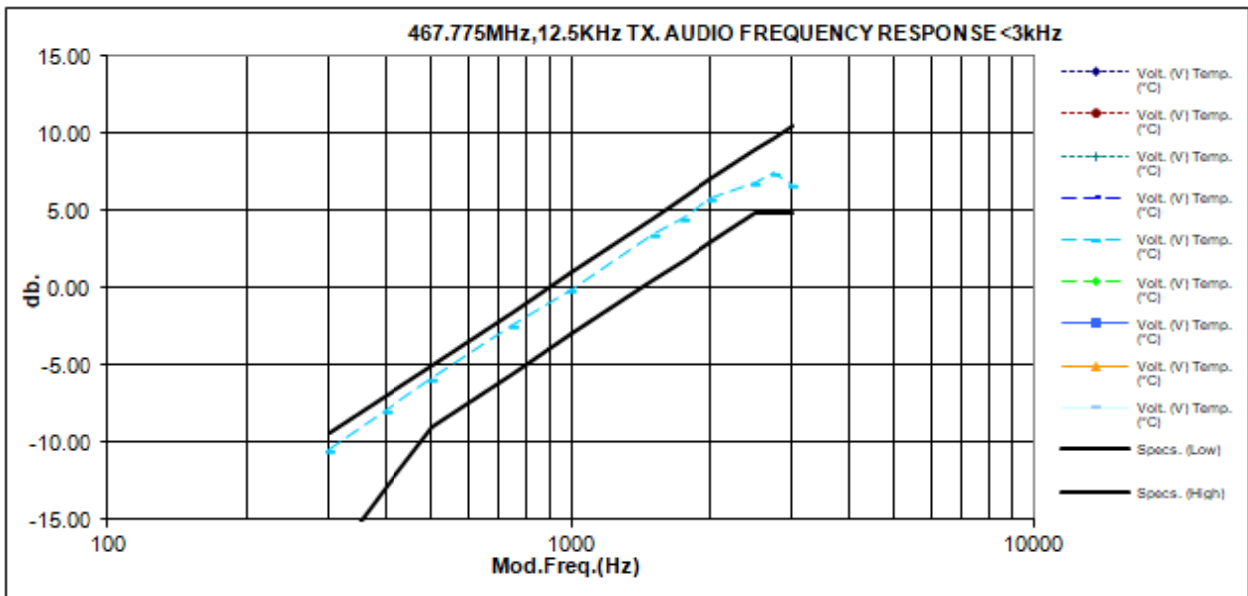

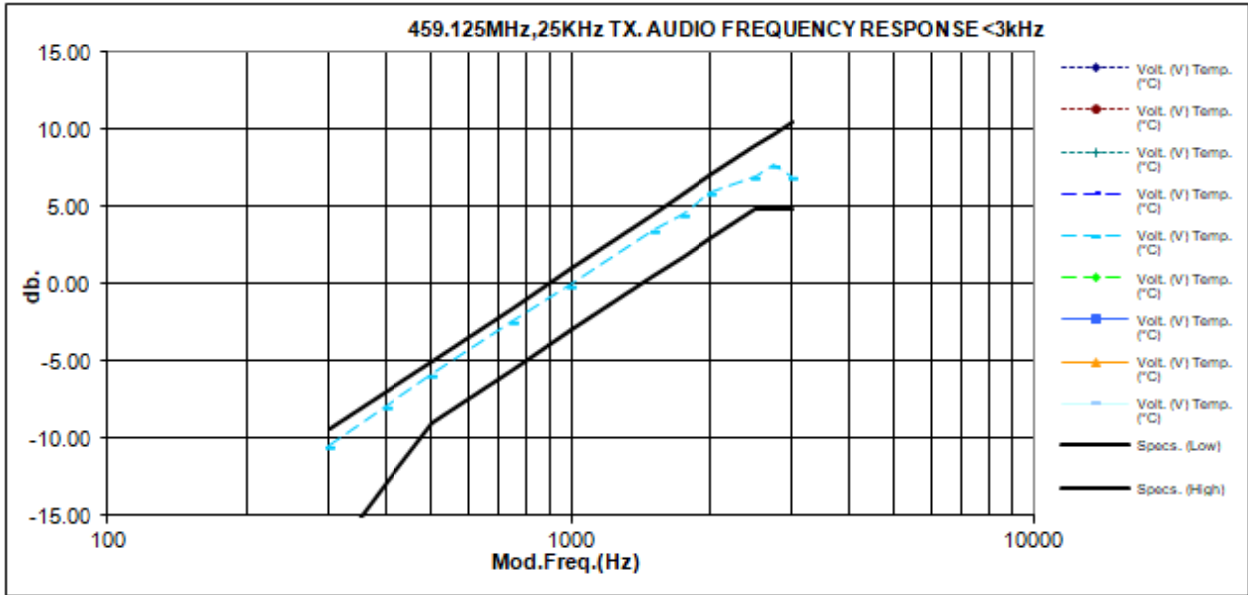

Not for FCC Review

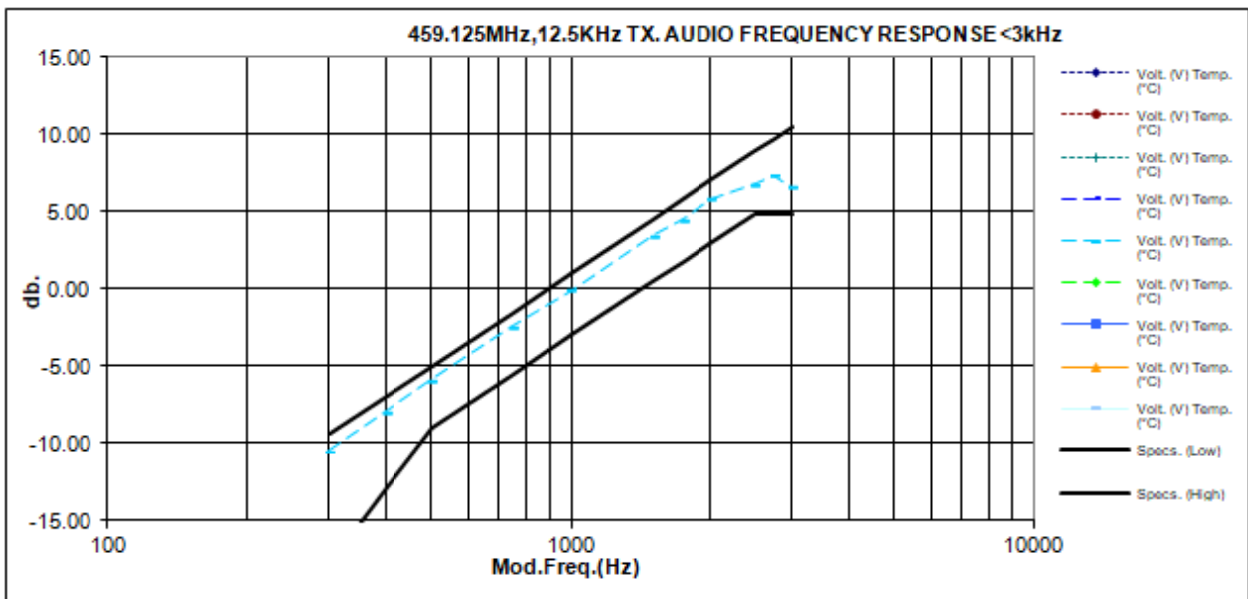

6.3.3. Test Limit

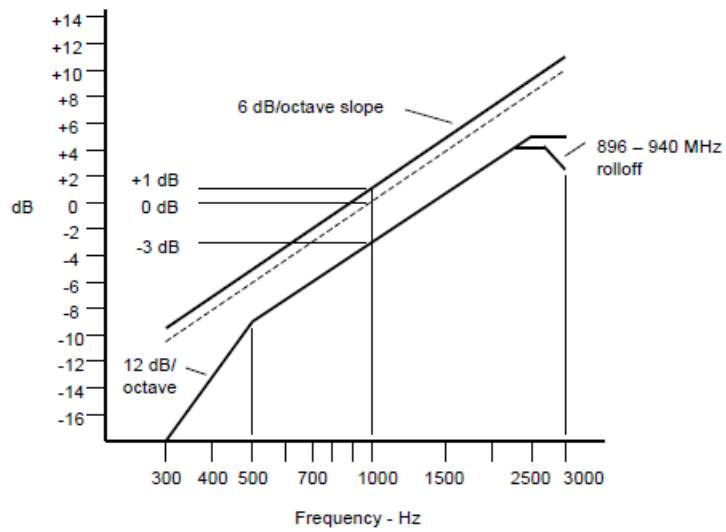

Note:

- o There are additional 6 dB per octave attenuation is allowed from 2.5KHz to 3KHz in equipment 25MHz to 869MHz radio.
- o Additional 6 dB per octave attenuation is allowed from 2.3KHz to 2.7KHz & additional 12 dB per octave attenuation is allowed from 2.7KHz to 3KHz in equipment 896MHz to 940MHz radio.

6.4. Audio Low Pass Filter Response

6.4.1. Test Setup

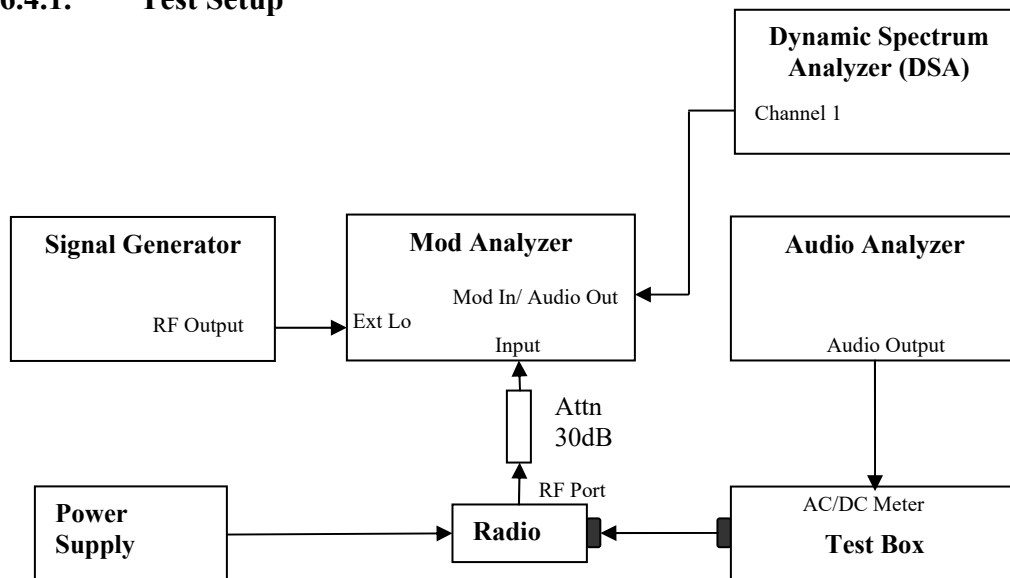

- 1) The DUT transmitter output port was connected to Modulation Analyzer.
- 2) Path loss for the measurement included.
- 3) Press 23.1SPCL on modulation analyzer to enable the external LO from Sigen.
- 4) Set the Sigen frequency to $F_c + 1.5$ MHz, RF output level to 0dBm without modulation.
- 5) Transmit the radio and set the audio analyzer to 1 kHz audio frequency and 60% of the Full rated system deviation.
- 6) Up the amplitude by 20dB.
- 7) On DSA, get the reference point to 0dB.
- 8) Vary the frequency on audio analyzer from 3 kHz to 20 kHz, record the audio tone from DSA.

6.4.2. Test Result

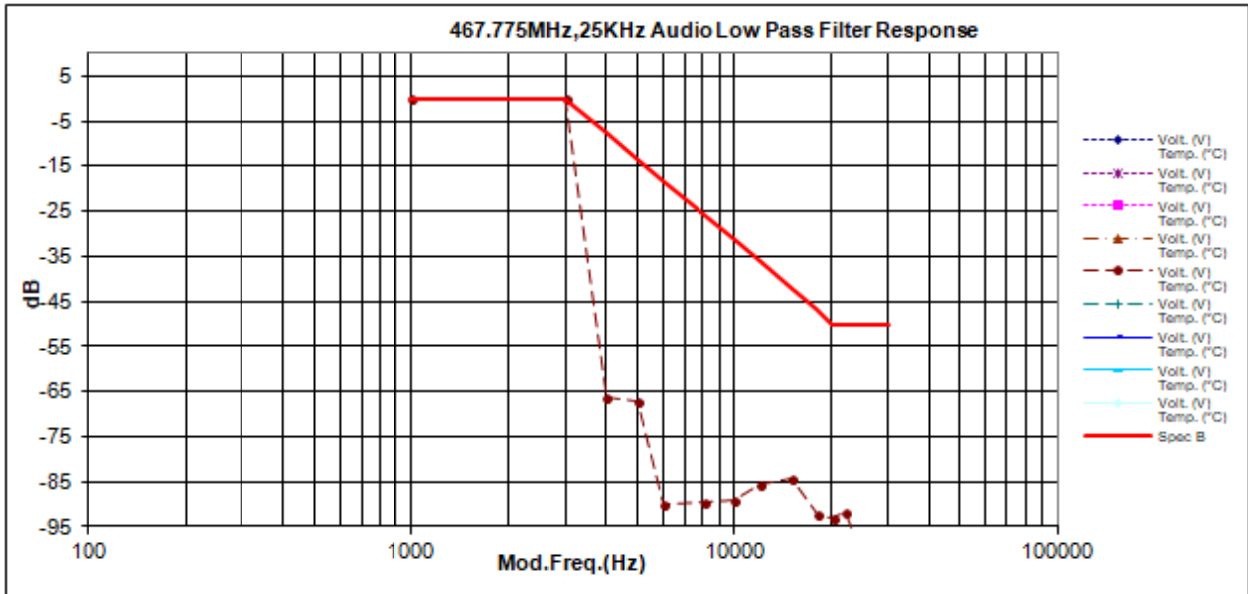

Not for FCC Review

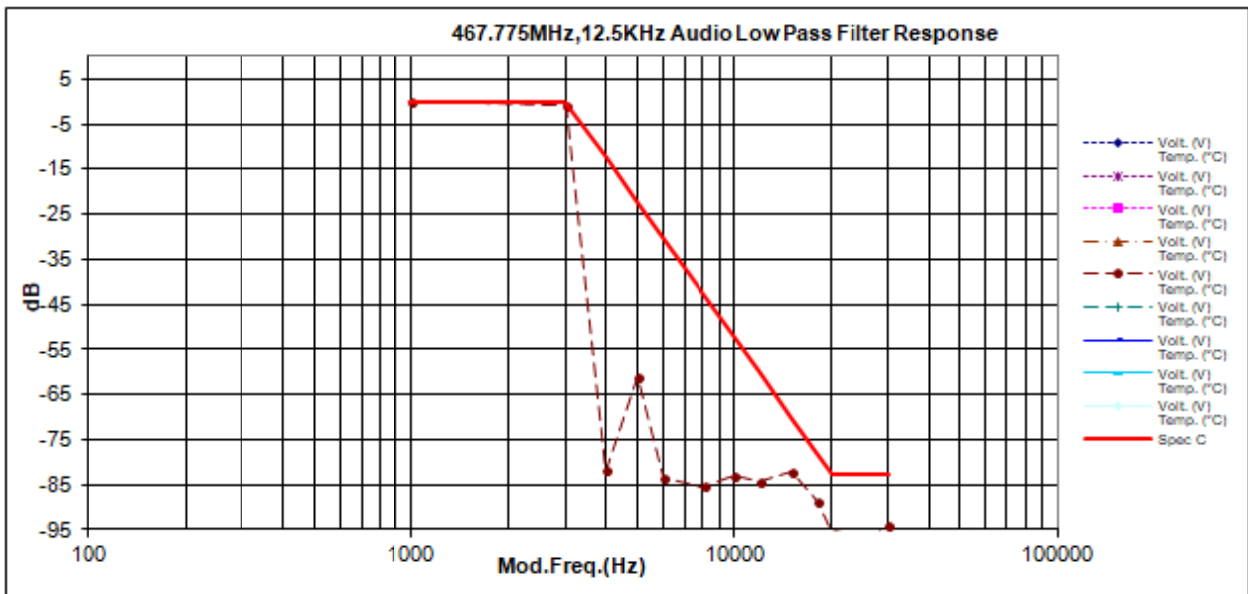

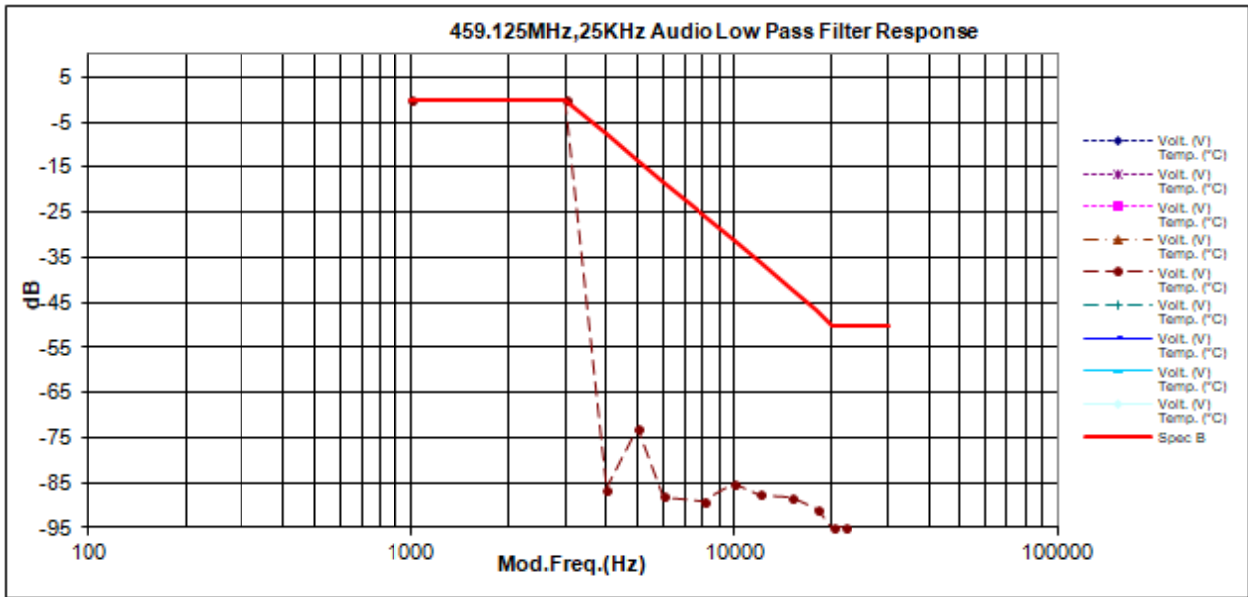

Not for FCC Review

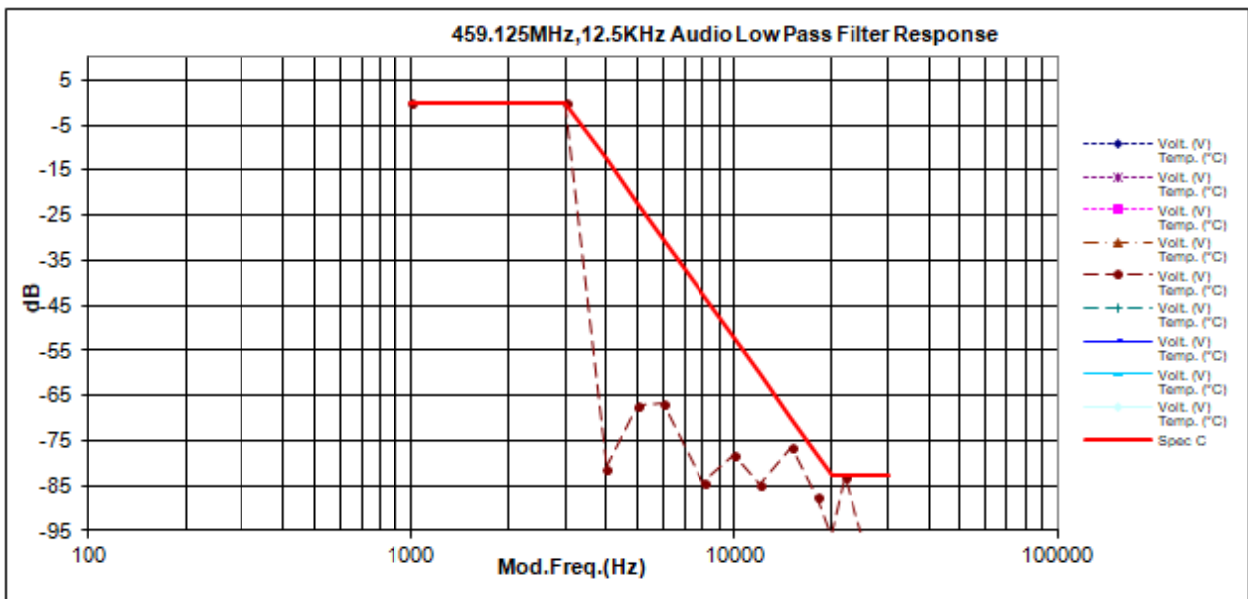

6.4.3. Test Limit

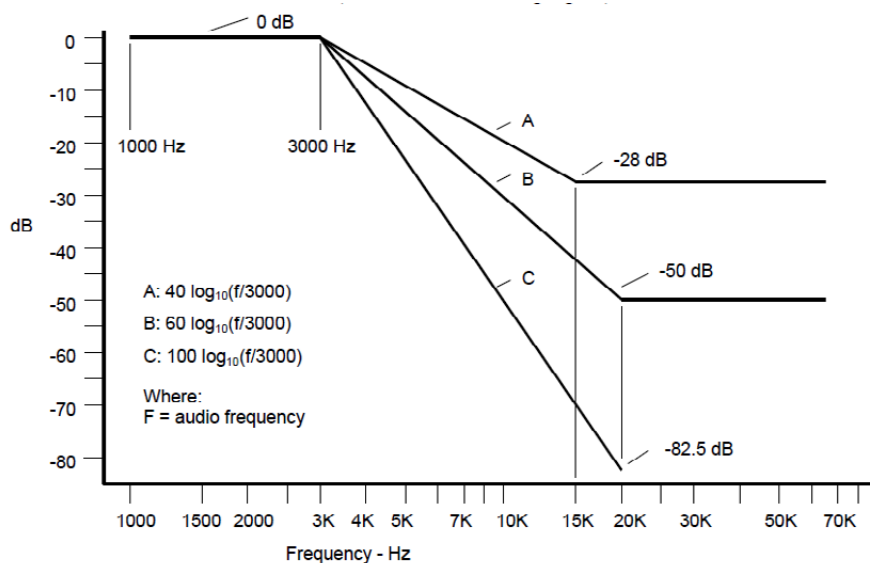

For audio frequencies above 3000 Hz, the audio response of the post limiter low-pass filter shall meet or exceed the following requirements:

- a) For equipment operating on 20, 25 or 30 kHz channel bandwidth in the 25 MHz to 174 MHz range:

At frequencies from 3000 Hz through 15,000 Hz the attenuation shall be greater than the attenuation at 1000 Hz by at least: $40 \log_{10}(f/3000)$ dB

where: f is the audio frequency in Hz.

At frequencies above 15,000 Hz, the attenuation shall be greater than the attenuation at 1000 Hz, by at least: 28 dB.

- b) For equipment operating with 25 kHz bandwidth channels between 406 and 512 MHz through 896 MHz, and between 929 MHz through 930 MHz:

At frequencies from 3000 Hz through 20,000 Hz, the attenuation shall be greater than the attenuation at 1000 Hz by at least: $60 \log_{10}(f/3000)$ dB

where: f is the audio frequency in Hz.

At frequencies above 20,000 Hz the attenuation shall be greater than the attenuation at 1000 Hz by at least: 50 dB.

- c) For equipment operating on channels between 896 MHz through 901 MHz, between 935 MHz through 940 MHz, and 12.5 or 15 kHz spaced channels in the frequency range 138-174 MHz and 406-512 MHz.

At frequencies from 3000 Hz through 20,000 Hz the attenuation shall be greater than the attenuation at 1000 Hz by at least: $100 \log_{10}(f/3000)$ dB

where: f is the audio frequency in Hz.

6.5. Modulation Limiting

6.5.1. Test Setup

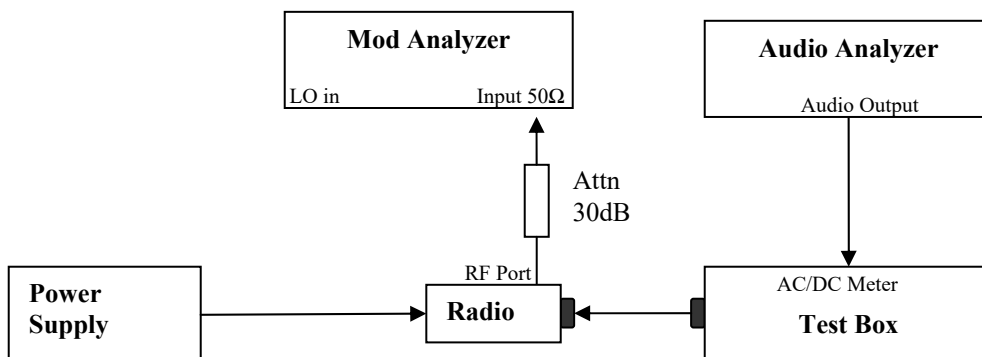

- 1) The DUT transmitter output port was connected to Modulation Analyzer.
- 2) Path loss for the measurement included.
- 3) Set the audio bandwidth filter to 15 kHz.
- 4) Transmit the radio and set the audio analyzer to 1 kHz audio frequency and 60% of the Full rated system deviation.
- 5) Record the frequency deviation as 0dB input level at 1kHz audio frequency.
- 6) Repeat the step and record the frequency deviation from -20 dB to 20dB by 5 dB increments and different audio freq 300 Hz, 2.5 kHz and 3 kHz.

6.5.2. Test Result

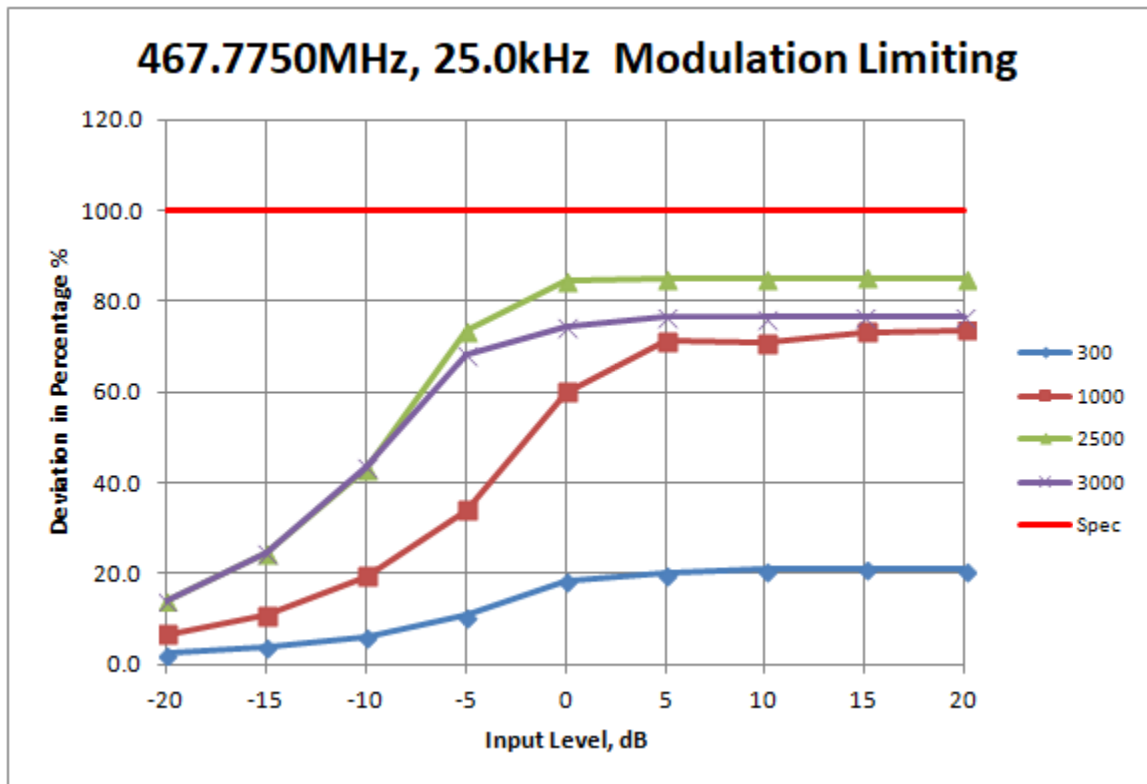

Not for FCC Review

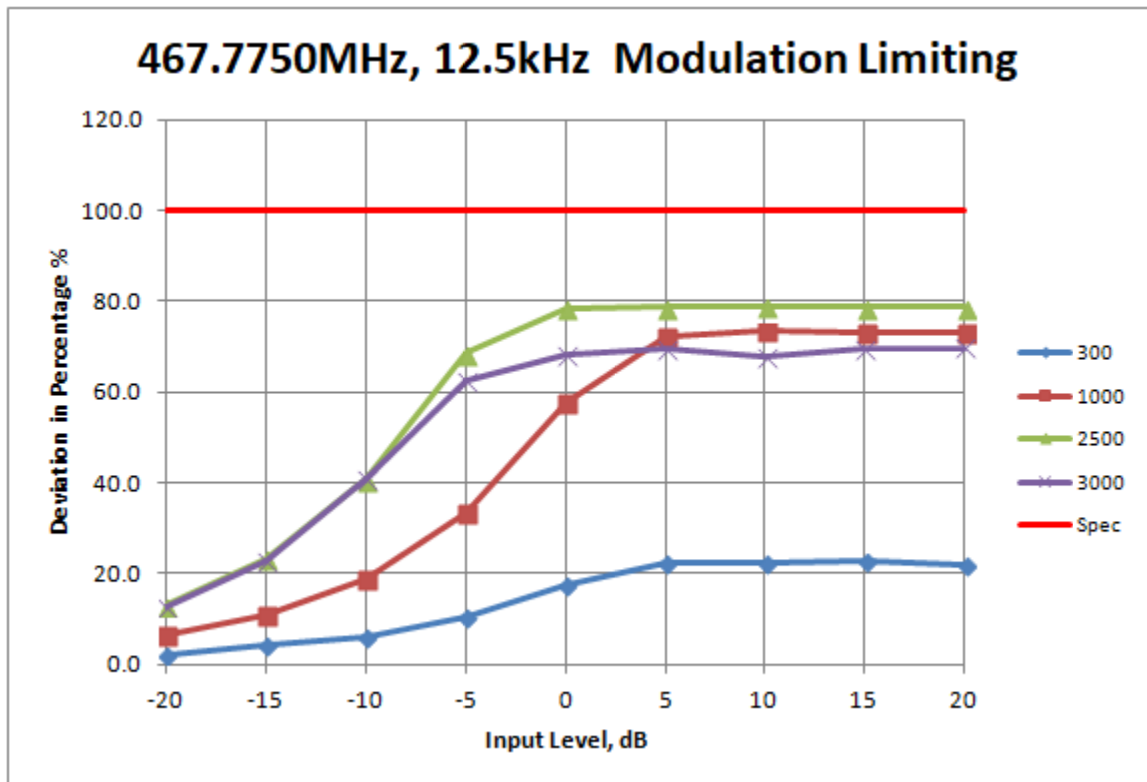

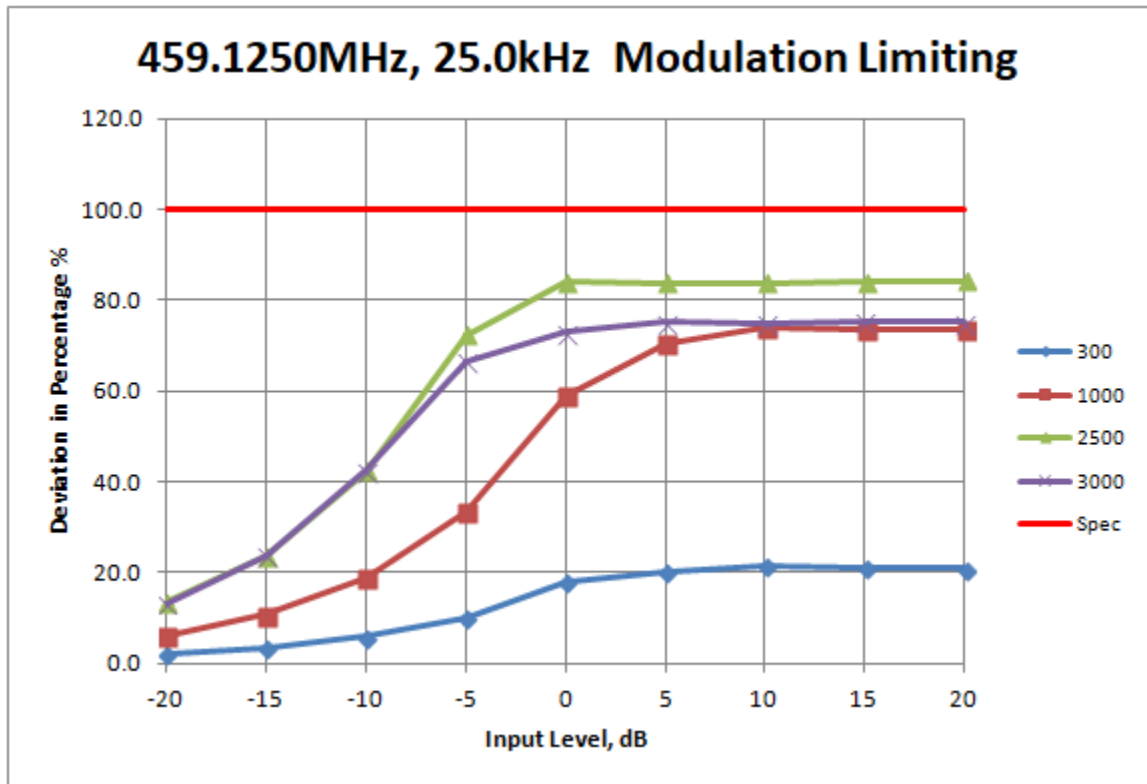

Not for FCC Review

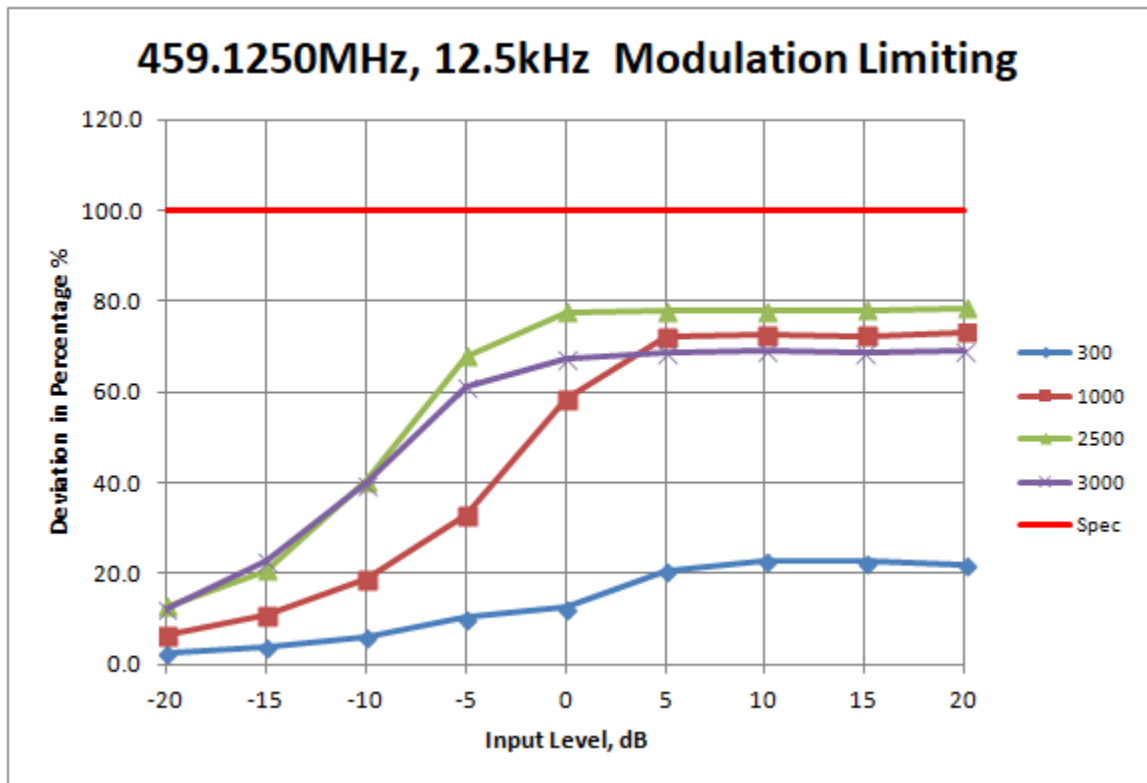

6.5.3. **Test Limit**
Modulation Limiting shall not exceed 100 percent.

6.6. Occupied Bandwidth

6.6.1. Test Setup (Analog)

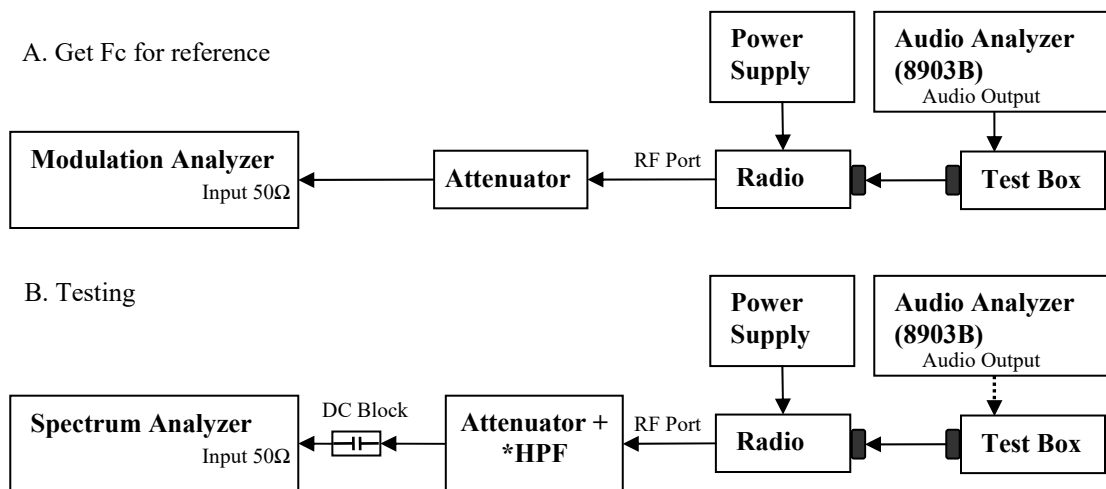

- 1) The DUT transmitter output port was connected to Modulation Analyzer.
- 2) Set the audio bandwidth filter to 15 kHz low pass filter and 50 kHz high pass filter.
- 3) Transmit the radio and set the audio analyzer to 2.5 kHz audio frequency and 50% of the rated deviation. Up the amplitude by 16 dB. Dekey the DUT.
- 4) Path loss for the measurement included.
- 5) Select the Occupied Bandwidth measurement for 99% Emissions Bandwidth Measurement.
- 6) Key in the Fc and Resolution Bandwidth (1 ~ 5 % of emission designator).
- 7) Transmit the DUT and record the occupied Bandwidth frequency.
- 8) Preset the spectrum analyzer for sideband spectrum measurement.
- 9) Set the span and Resolution Bandwidth (according to FCC/ ISED standard).
- 10) Save the screen shot as modulated signal
- 11) Remove the audio tone from audio analyzer to capture unmodulated signal.

* Only HPF added for Mask 80.211 measurement with attenuator.

BANDWIDTH CALCULATIONS:

Carson's Rule for FM modulation is utilized to compute the bandwidth shown in the FCC emission designator. Carson's Rule is: $BW = 2 * (M + D)$

where: BW = Bandwidth
M = Maximum modulating frequency
D = Deviation

Standard Audio Modulation (12.5 kHz Channelization, Analog Voice):

Emission Designator 11K0F3E

In this case, the maximum modulating frequency is 3.0 kHz with a 2.5 kHz deviation.

$$BW = 2(M+D) = 2*(3.0 \text{ kHz} + 2.5 \text{ kHz}) = 11 \text{ kHz} \rightarrow 11K0$$

F3E portion of the designator indicates voice.

Therefore, the entire designator for 12.5 kHz channelization analog voice is 11K0F3E.

Standard Audio Modulation (25 kHz Channelization, Analog Voice):

Emission Designator 16K0F3E

In this case, the maximum modulating frequency is 3.0 kHz with a 5 kHz deviation.

$$BW = 2(M+D) = 2*(3.0 \text{ kHz} + 5 \text{ kHz}) = 16 \text{ kHz} \rightarrow 16K0$$

F3E portion of the designator indicates voice.

Therefore, the entire designator for 25 kHz channelization analog voice is 16K0F3E.

6.6.2. Test Result (Analog)

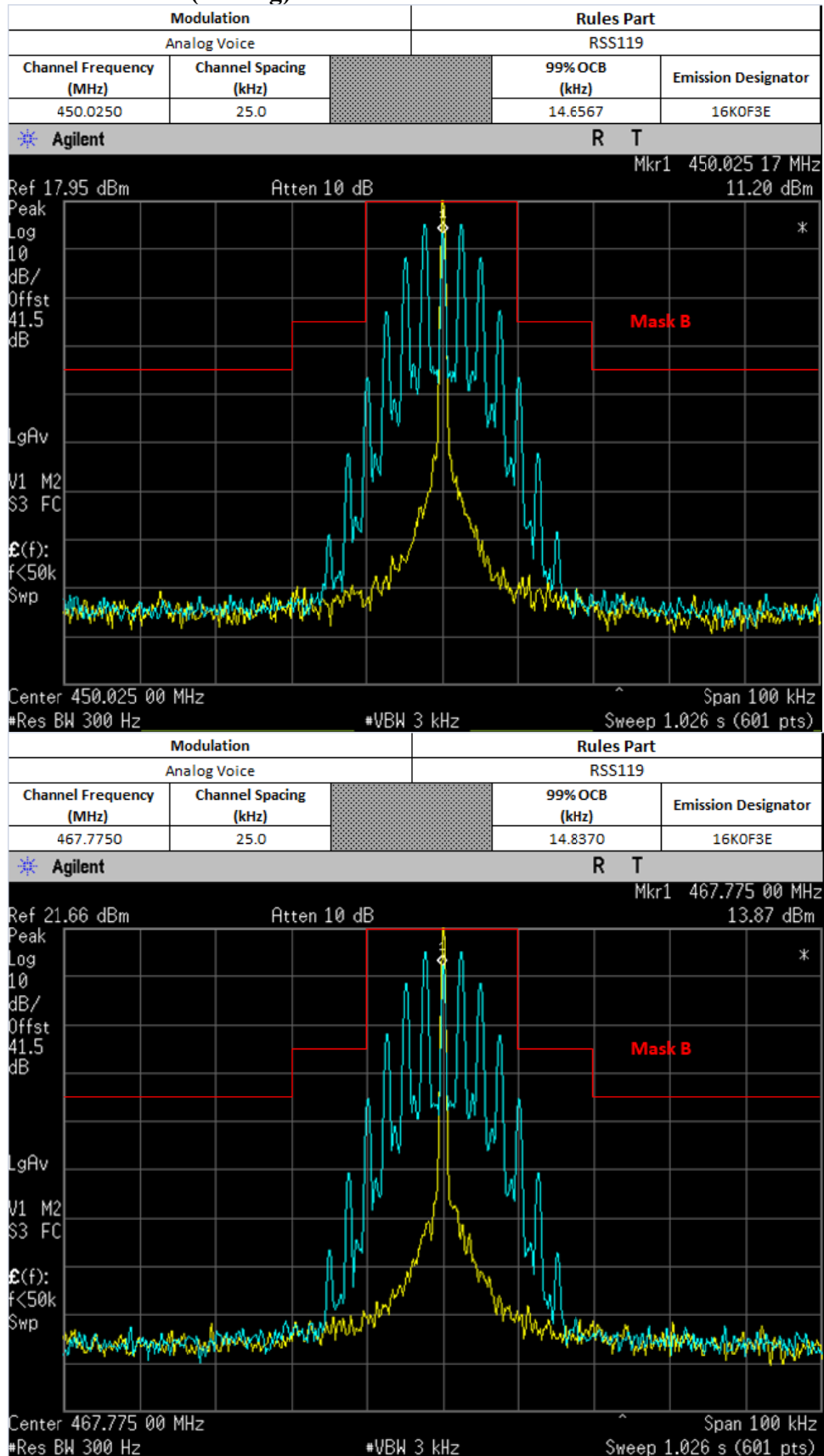

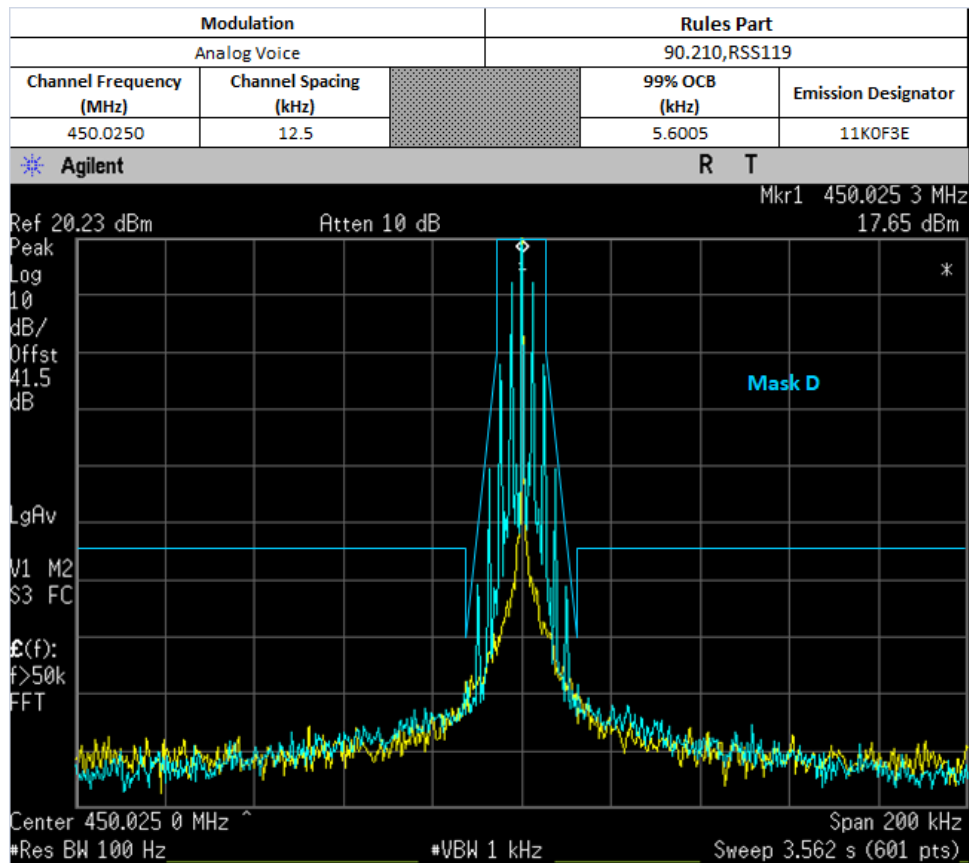

6.6.3. Test Setup (Digital)

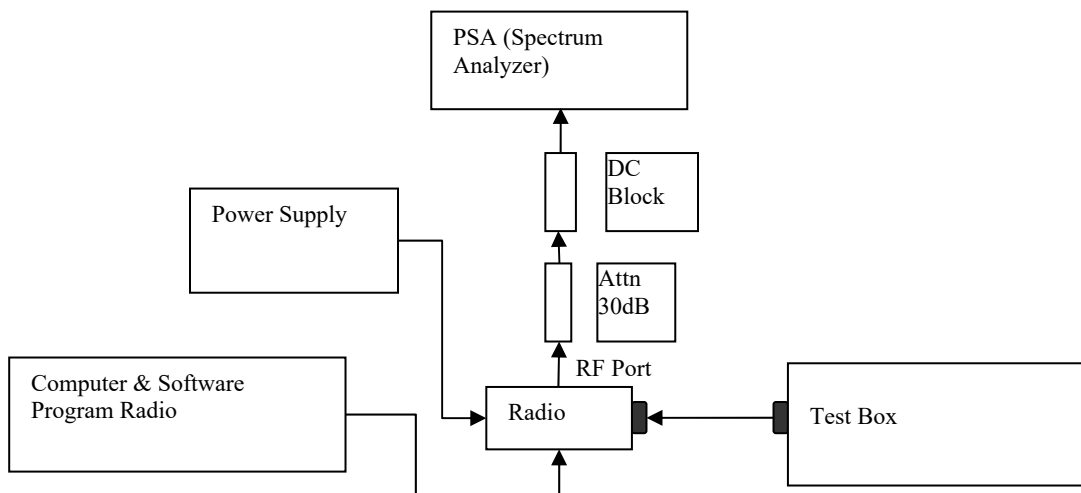

- 1) Program and set radio to operate in desire test frequency and digital mode with modulation. (*4FSK, C4FM or other digital modulation form).
- 2) Path loss for the measurement included.
- 3) Select the Occupied Bandwidth measurement for 99% Emissions Bandwidth Measurement.
- 4) Key in the Fc and Resolution Bandwidth (1 ~ 5 % of emission designator).
- 5) Transmit the DUT and record the occupied Bandwidth frequency.
- 6) Preset the spectrum analyzer for modulation emission spectrum measurement.
- 7) Set the span and Resolution Bandwidth (according to FCC/ ISED standard).
- 8) Capture the screen shot as modulated signal.

*Note:

- For Digital Modulation, 12.5 kHz Data F1D & FXD would be the same. Therefore only measurements with F1D modulation shown below.
- For Digital Modulation, 12.5 kHz Data F1E & FXE would be the same. Therefore only measurements with F1E modulation shown below.

6.6.4. Test Result (Digital) **Not Applicable**

6.6.5. Test Limit

The 99% occupied bandwidth is the width of a frequency band such that, below the lower and above the upper frequency limits, the mean powers emitted are each equal to a specified percentage 0.5% of the total mean transmitted power.

6.7. Band Edge Conducted Spurious Emission (Part 22)

6.7.1. Test Setup (Analog)

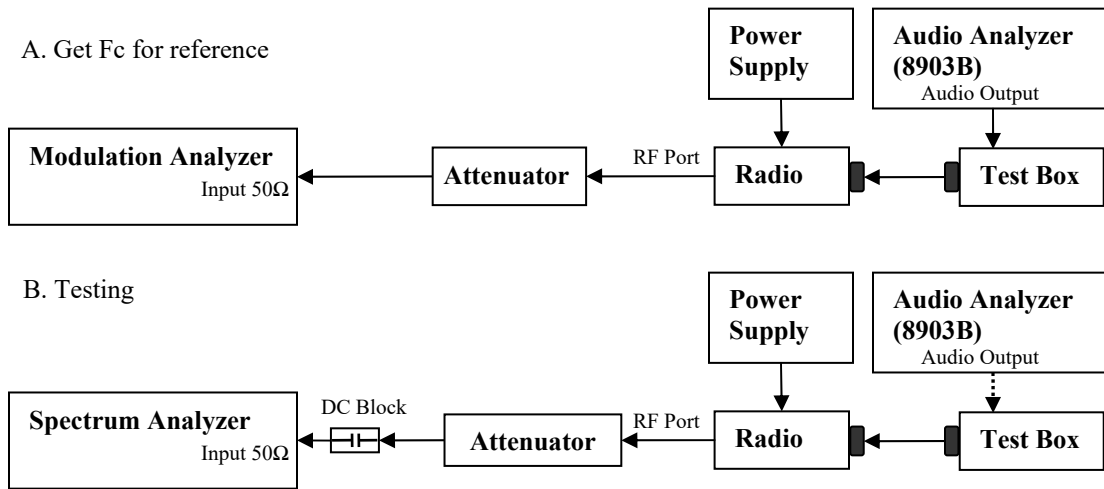

- 1) The DUT transmitter output port was connected to Modulation Analyzer.
- 2) Set the audio bandwidth filter to 15 kHz low pass filter and 50 kHz high pass filter.
- 3) Transmit the radio and set the audio analyzer to 2.5 kHz audio frequency and 50% of the rated deviation. Up the amplitude by 16 dB. Dekey the DUT.
- 4) Path loss for the measurement included.
- 5) Select the Occupied Bandwidth measurement for 99% and 26dB Emissions Bandwidth Measurement.
- 6) Key in the Fc and Resolution Bandwidth.
- 7) Transmit the DUT and record the occupied Bandwidth frequencies.
- 8) Preset the spectrum analyzer for band edge measurement.
- 9) The band edges of lowest and highest channels were measured.
- 10) Key in the Lowest and highest channel frequency, span is 60 kHz and Resolution Bandwidth is at least 1% of Emission Bandwidth.
- 11) Save the screen shot as modulated signal.
- 12) Remove the audio tone from audio analyzer to capture unmodulated signal.

*Note:

- For emission designator ending with F3E, 16K0F3E is the worst case and therefore only 16K0F3E will be shown.

6.7.2. Test Result (Analog) **Not Applicable**

6.7.3. Test Setup (Digital)

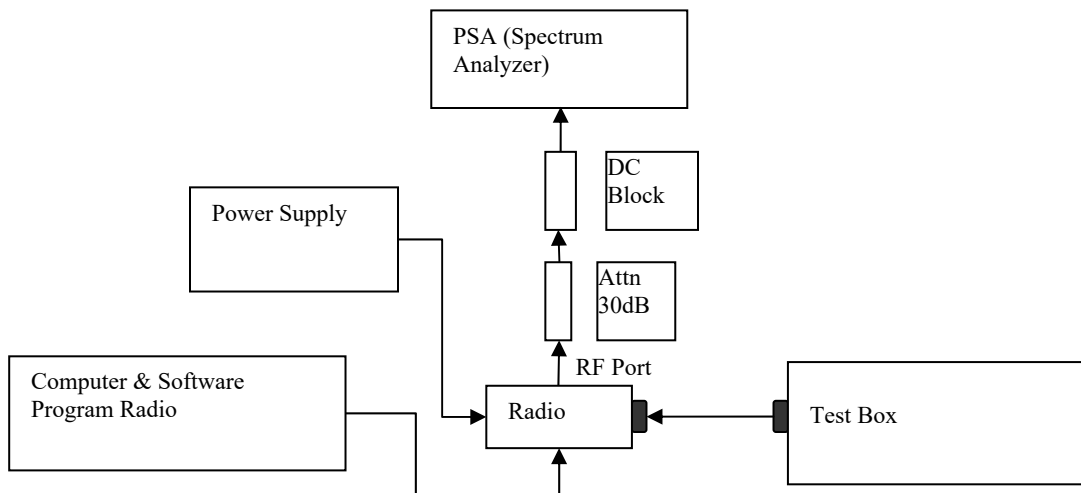

- 1) Program and set radio to operate in desire test frequency and digital mode with modulation. (*4FSK, C4FM or other digital modulation form).
- 2) Path loss for the measurement included.
- 3) Select the Occupied Bandwidth measurement for 99% and 26dB Emissions Bandwidth Measurement.
- 4) Key in the Fc and Resolution Bandwidth.
- 5) Transmit radio record the occupied Bandwidth frequencies.
- 6) Preset the spectrum analyzer for band edge measurement.
- 7) Key in the lowest and highest channels frequency, span is 60 kHz and Resolution Bandwidth is at least 1% of Emission Bandwidth.
- 8) Save the screen shot.

*Note:

- For Digital Modulation, 12.5 kHz Data F1D & FXD would be the same. Therefore only measurements with F1D modulation shown below.
- For Digital Modulation, 12.5 kHz Data F1E & FXE would be the same. Therefore only measurements with F1E modulation shown below.

6.7.4. Test Result (Digital) **Not Applicable**

6.7.5. Test Limit

The power of any emission outside of the authorized operating frequency ranges must be attenuated below the transmitting power (P) by a factor of at least $43 + 10 \log(P)$ dB.

6.8. Transient Frequency Behavior

6.8.1. Test Setup

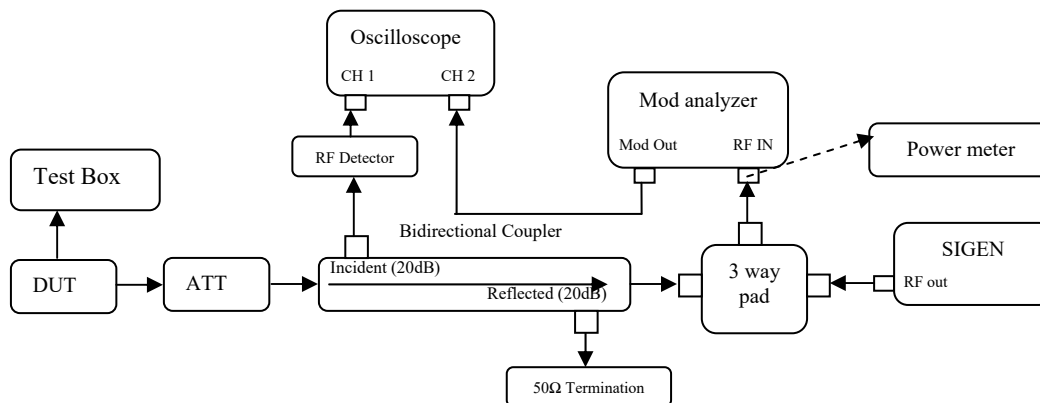

- 1) Connect the setup as figure above.
- 2) Path loss for the measurement included.
- 3) Set on Sigen with the assigned center frequency, internal 1 kHz FM tone.
FM Deviation: Analog 25kHz Channel Spacing = 25 kHz
Analog 12.5 kHz Channel Spacing = 12.5 kHz
C4FM = 12.5 kHz
- 4) Turn on 50 kHz high pass filter and 15 kHz low pass filter on modulation analyzer.
- 5) Supply sufficient attenuation ATT to provide the output power of $\leq -11\text{dBm}$ into power meter when DUT is keying up.
- 6) Note the power level on power meter and dekey the DUT.
- 7) Adjust the amplitude of the signal generator to the level power meter, maintained the amplitude throughout the rest of the measurement.
- 8) Connect the output to modulation analyzer.
- 9) Reduce 30dB attenuation and transmit the radio to get the trigger line.
- 10) Capture the screen shot for key-up (rising edge) and de-key (falling edge) mode.

6.8.2. Test Result

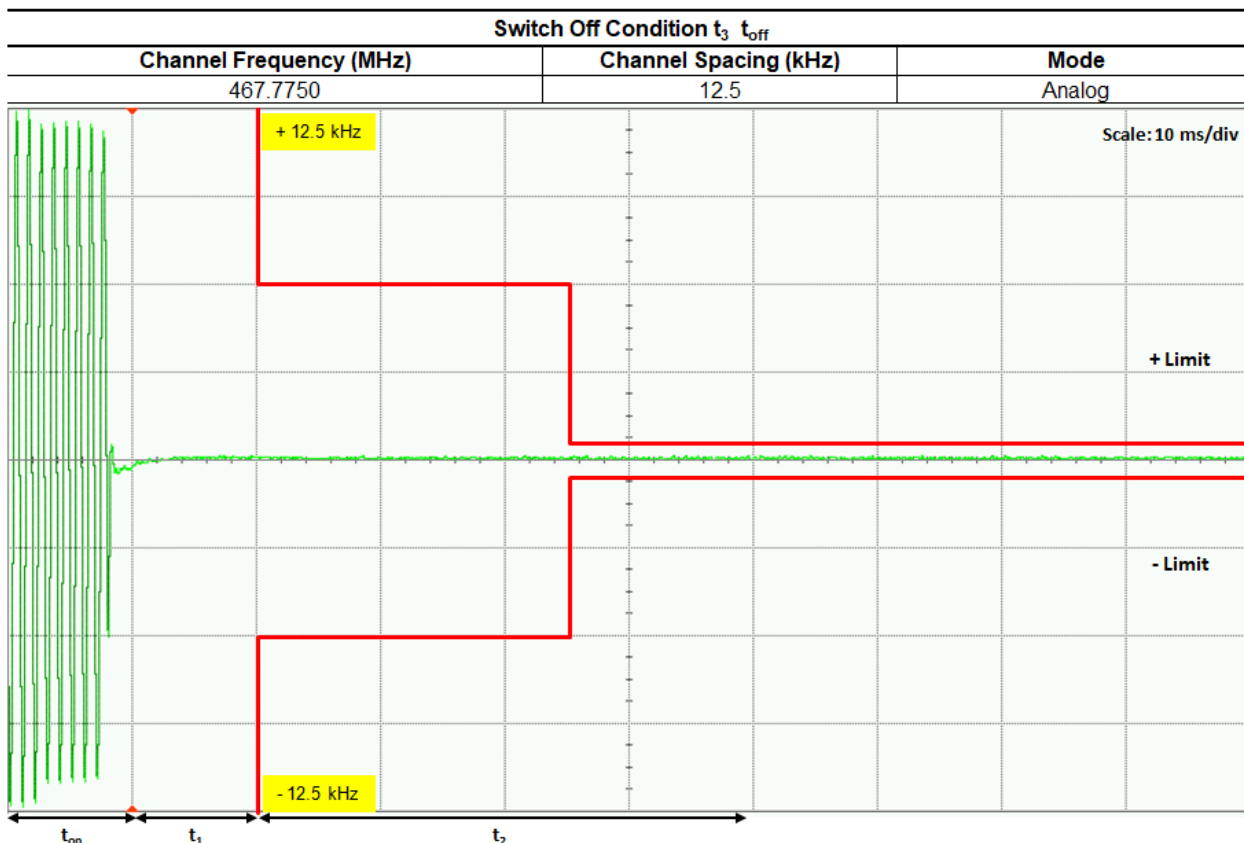
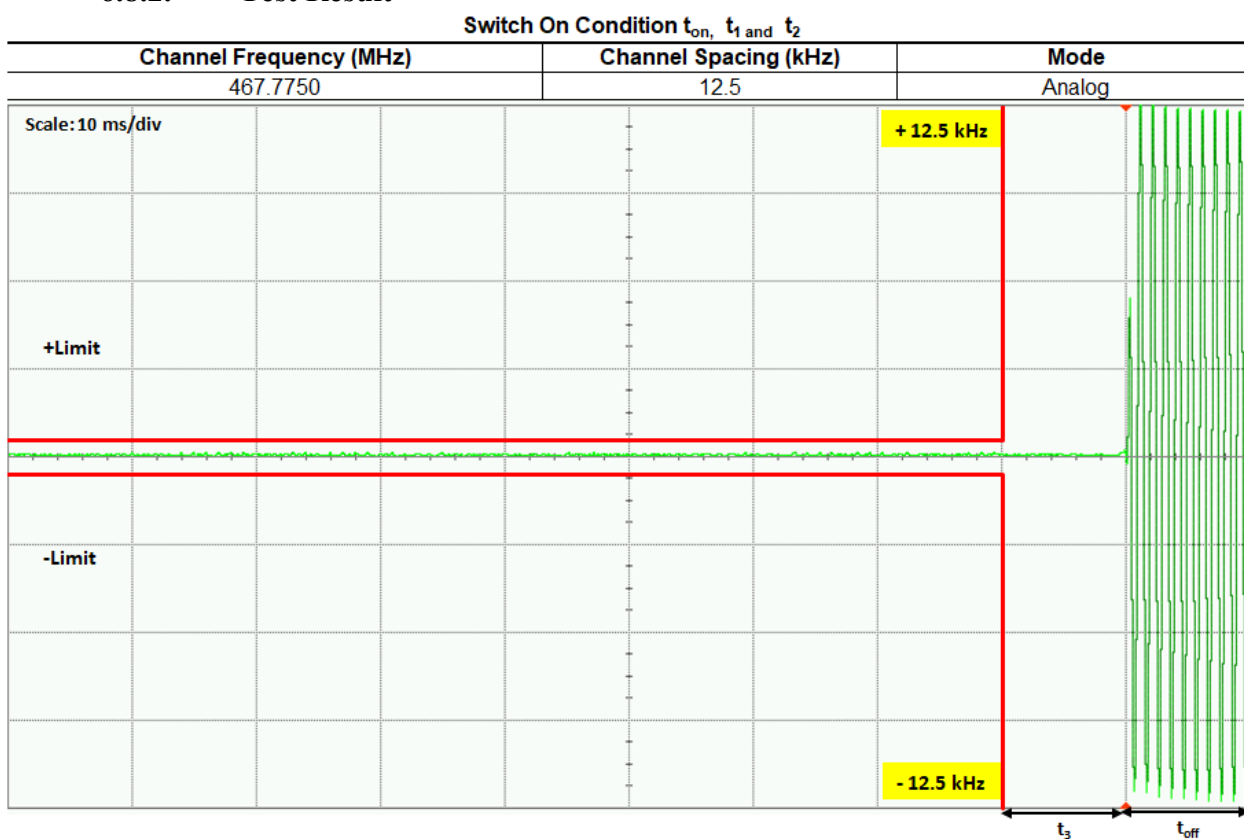

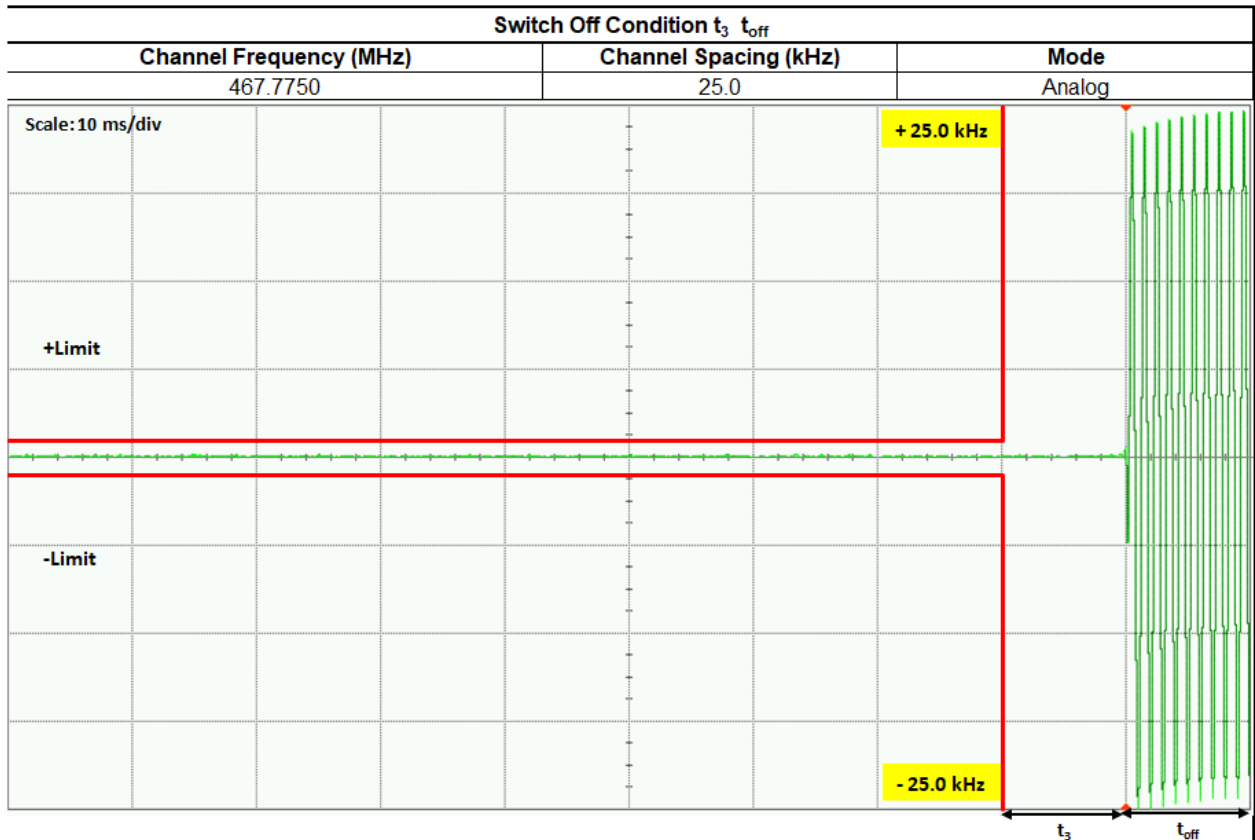
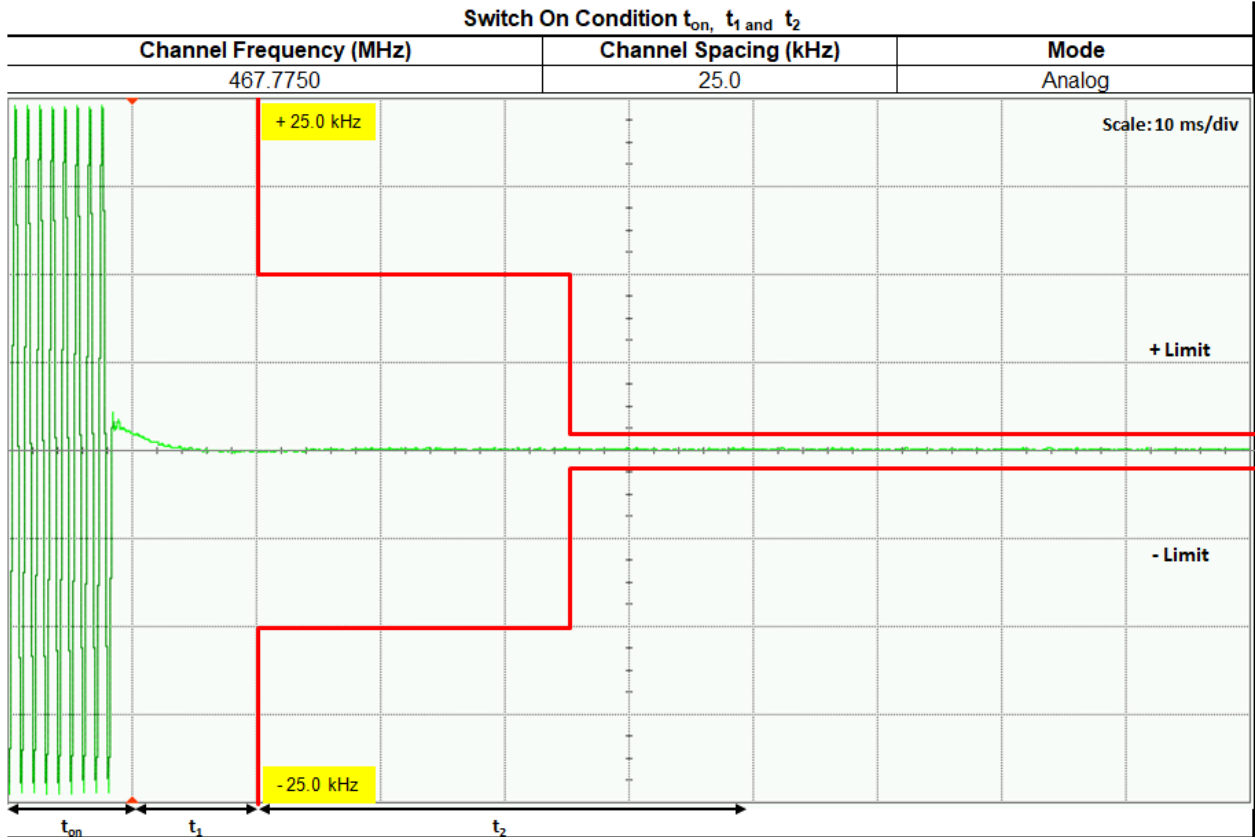

Not for FCC Review

6.8.3. Test Limit

Transmitters designed to operate in the 150-174 MHz and 421-512 MHz frequency bands must maintain transient frequencies within the maximum frequency difference limits during the time intervals indicated:

Time intervals ^{1 2}	Maximum frequency difference ³	All equipment	
		150 to 174 MHz	421 to 512 MHz
Transient Frequency Behavior for Equipment Designed to Operate on 25 kHz Channels			
t ₁ ⁴	±25.0 kHz	5.0 ms	10.0 ms
t ₂	±12.5 kHz	20.0 ms	25.0 ms
t ₃ ⁴	±25.0 kHz	5.0 ms	10.0 ms
Transient Frequency Behavior for Equipment Designed to Operate on 12.5 kHz Channels			
t ₁ ⁴	±12.5 kHz	5.0 ms	10.0 ms
t ₂	±6.25 kHz	20.0 ms	25.0 ms
t ₃ ⁴	±12.5 kHz	5.0 ms	10.0 ms
Transient Frequency Behavior for Equipment Designed to Operate on 6.25 kHz Channels			
t ₁ ⁴	±6.25 kHz	5.0 ms	10.0 ms
t ₂	±3.125 kHz	20.0 ms	25.0 ms
t ₃ ⁴	±6.25 kHz	5.0 ms	10.0 ms

¹ t_{on} is the instant when a 1 kHz test signal is completely suppressed, including any capture time due to phasing.

t₁ is the time period immediately following t_{on}.

t₂ is the time period immediately following t₁.

t₃ is the time period from the instant when the transmitter is turned off until t_{off}.

t_{off} is the instant when the 1 kHz test signal starts to rise.

² During the time from the end of t₂ to the beginning of t₃, the frequency difference must not exceed the limits specified in §90.213.

³ Difference between the actual transmitter frequency and the assigned transmitter frequency.

⁴ If the transmitter carrier output power rating is 6 watts or less, the frequency difference during this time period may exceed the maximum frequency difference for this time period.

6.9. Adjacent Channel Power

6.9.1. Test Setup (Analog)

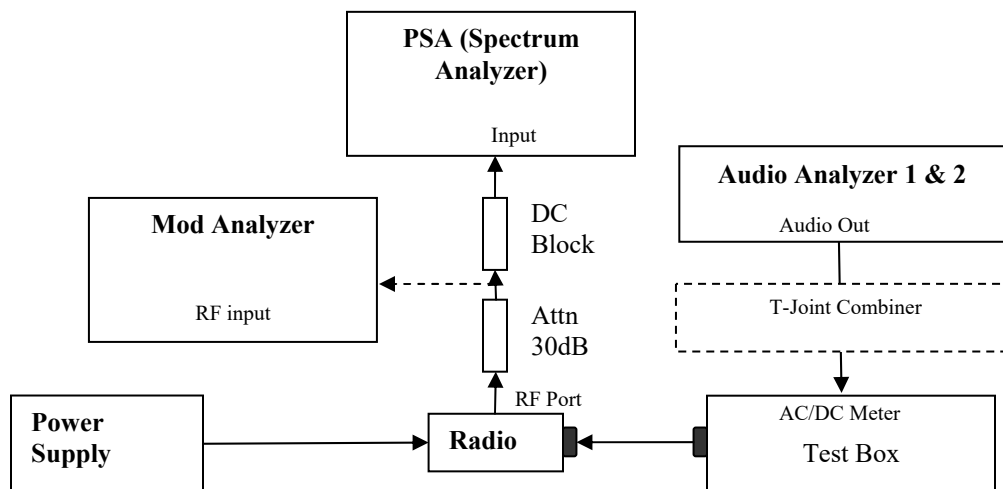

- 1) The DUT transmitter output port was connected to modulation analyzer.
- 2) Transmit the radio and turn on 1st audio analyzer with audio frequency 650Hz, 50% rated deviation, and record the amplitude value as AmpT1.
- 3) Turn off Audio analyzer 1 and turn on audio analyzer 2, set the audio frequency to 2.2 kHz and 50% deviation. Record the amplitude as AmpT2.
- 4) Turn both audio analyzers ON and up 10dB amplitude level.
- 5) Connect the output to PSA and set to assigned center frequency.
- 6) Set Span, Resolution Bandwidth and Video Bandwidth per rules part.
- 7) Transmit the radio and record the Adjacent Channel Power value in dBc.

6.9.2. Test Result **Not Applicable**

6.9.3. Test Setup (Digital)

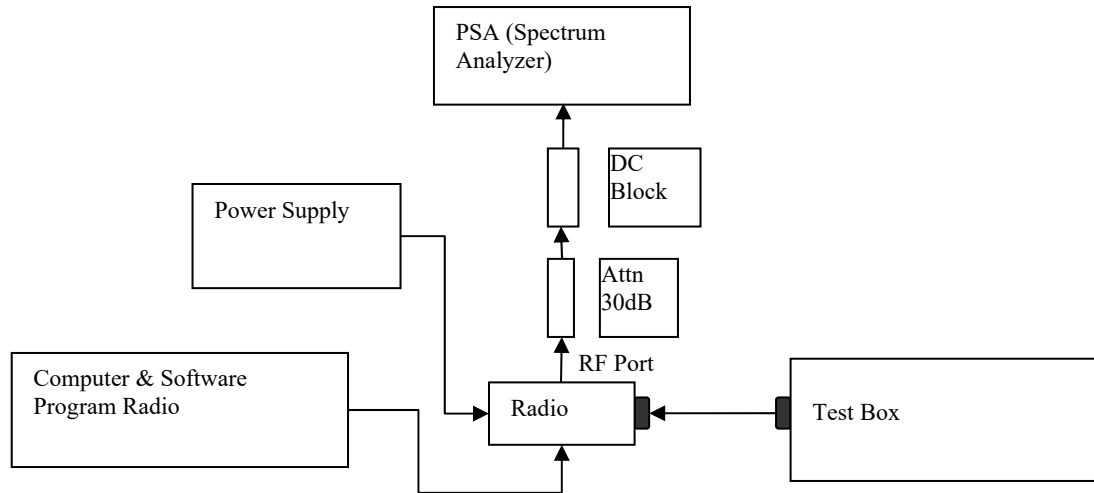

- 1) Program and set radio to operate in desire test frequency and digital mode with modulation. (4FSK, C4FM or other digital modulation form).
- 2) Prepare setup as per picture.
- 3) Turn on the ACP Measurement – Press Measure, ACP.
- 4) Set Span, Resolution Bandwidth and Video Bandwidth as per rules part.
- 5) Transmit the radio and record the Adjacent Channel Power value in dBc.

6.9.4. Test Result **Not Applicable**

6.9.5. Test Limit

12.5 kHz MOBILE TRANSMITTER ACP REQUIREMENTS

Offset from center frequency (kHz)	Measurement bandwidth (kHz)	Maximum ACP relative (dBc)
9.375	6.25	-40
15.625	6.25	-60
21.875	6.25	-60
37.50	25.00	-60
62.50	25.00	-65
87.50	25.00	-65
150.00	100	-65
250.00	100	-65
350.00	100	-65
>400 to 12 MHz	30 (s)	-75
12 MHz to paired receive band	30 (s)	-75
In the paired receive band	30 (s)	-100

25 kHz MOBILE TRANSMITTER ACP REQUIREMENTS

Offset from center frequency (kHz)	Measurement bandwidth (kHz)	Maximum ACP relative (dBc)
15.625	6.25	-40
21.875	6.25	-60
37.50	25	-60
62.50	25	-65
87.50	25	-65
150.00	100	-65
250.00	100	-65
350.00	100	-65
>400 kHz to 12 MHz	30 (s)	-75
12 MHz to paired receive band	30 (s)	-75
In the paired receive band	30 (s)	-100

12.5 kHz BASE TRANSMITTER ACP REQUIREMENTS

Offset from center frequency (kHz)	Measurement bandwidth (kHz)	Maximum ACP (dBc)
9.375	6.25	-40
15.625	6.25	-60
21.875	6.25	-60
37.5	25	-60
62.5	25	-65
87.5	25	-65
150	100	-65
250	100	-65
350.00	100	-65
>400 kHz to 12 MHz	30 (s)	-80
12 MHz to paired receive band	30 (s)	-80
In the paired receive band	30 (s)	1-85

25 kHz BASE TRANSMITTER ACP REQUIREMENTS

Offset from center frequency (kHz)	Measurement bandwidth (kHz)	Maximum ACP (dBc)
15.625	6.25	-40
21.875	6.25	-60
37.5	25	-60
62.5	25	-65
87.5	25	-65
150	100	-65
250	100	-65
350	100.00	-65
>400 kHz to 12 MHz	30 (s)	-80
12 MHz to paired receive band	30 (s)	-80
In the paired receive band	30 (s)	1-85

6.10. Conducted Spurious Emission

6.10.1. Test Setup

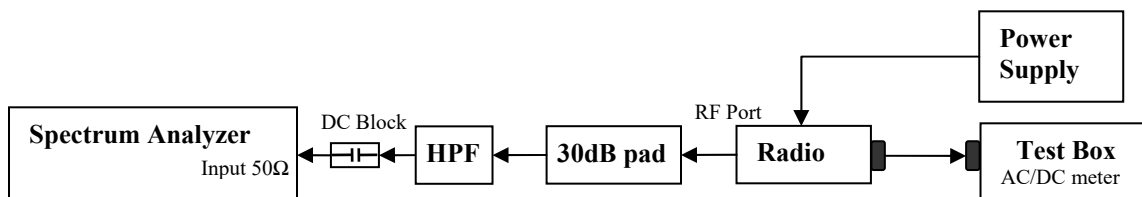

- 1) The DUT transmitter output port was connected to Spectrum Analyzer with above setup.
- 2) Program and set radio to operate in desire test frequency and mode. (Analog / digital modulation form).
- 3) Path loss for the measurement included.
- 4) Set the PSA Resolution Bandwidth as per rules part.
- 5) Set the Ref offset from the pathloss offset calibration file.
- 6) Adjust the center frequency of the spectrum analyzer for incremental coverage of the range from:
 - a. 9 KHz to $F_c - \text{Test Bandwidth}$
 - b. $F_c + \text{Test Bandwidth}$ to $2F_c - 5\text{MHz}$.
- 7) Key up the DUT, Peak Search the highest Spur and record the levels of spurious emissions
- 8) Dekey the DUT.
- 9) Turn On High Pass Filter path and Key up the DUT.
- 10) Adjust the PSA Freq for incremental coverage of range from $2F_c$ to $10F_c$
- 11) Key up the DUT and record the highest spur levels of spurious emissions.

6.10.2. Test Result (Analog)

Analog: 450.025 MHz, 25.0kHz Channel Spacing, Max Power

RSS 119

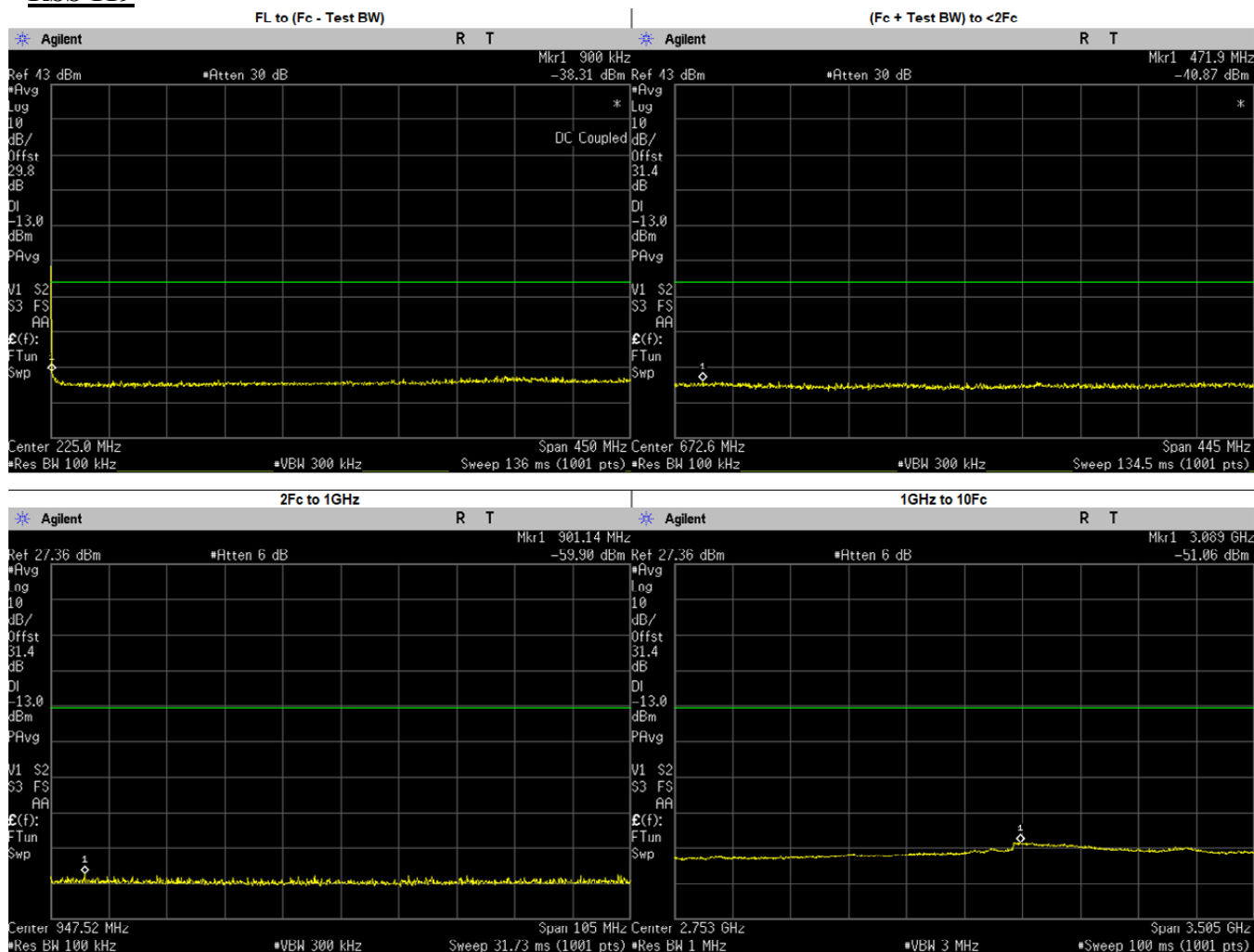

Frequency Range	Highest Spur Frequency (MHz)	Spurious Level (dBm)	Failing Limit (dBm)	Results
FL to (Fc - Test BW)	0.9089	-38.3100	-13.00	PASS
(Fc + Test BW) to <2Fc	471.8852	-40.8700	-13.00	PASS
2Fc to 1GHz	901.1371	-59.9000	-13.00	PASS
	900.0500	-61.7347	-13.00	PASS
1GHz to 10Fc	3089.1290	-51.0600	-13.00	PASS
	1350.0750	-55.5477	-13.00	PASS
	1800.1000	-55.0792	-13.00	PASS
	2250.1250	-54.8562	-13.00	PASS
	2700.1500	-54.2274	-13.00	PASS
	3150.1750	-51.4738	-13.00	PASS
	3600.2000	-52.9500	-13.00	PASS
	4050.2250	-52.9618	-13.00	PASS
	4500.2500	-53.8014	-13.00	PASS

**Analog: 450.025 MHz, 25.0kHz Channel Spacing, Low Power
 RSS 119**

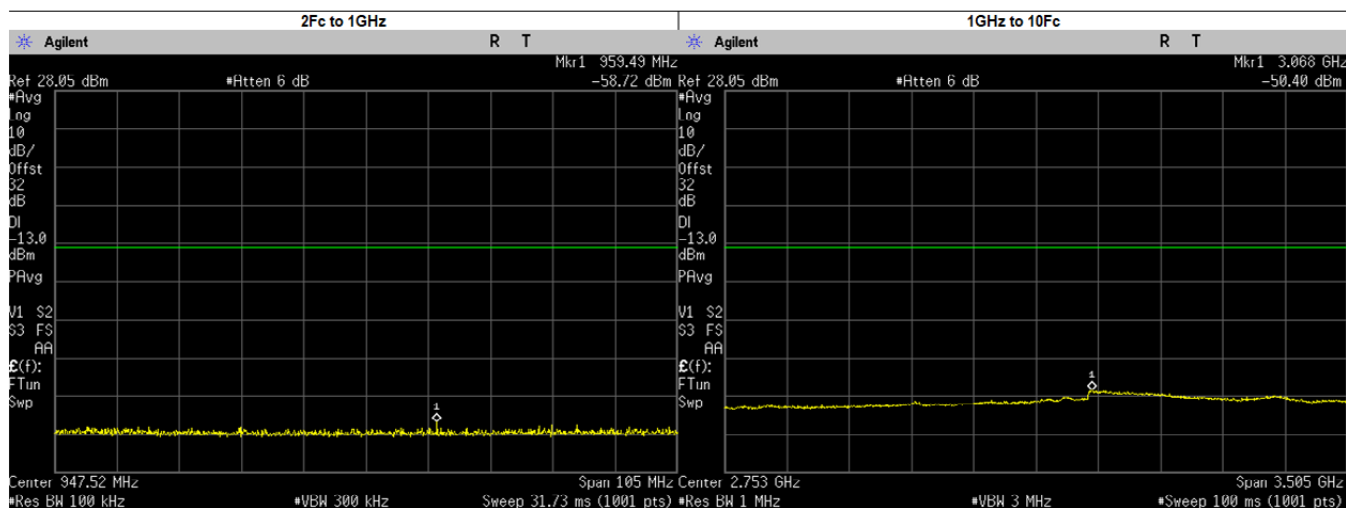
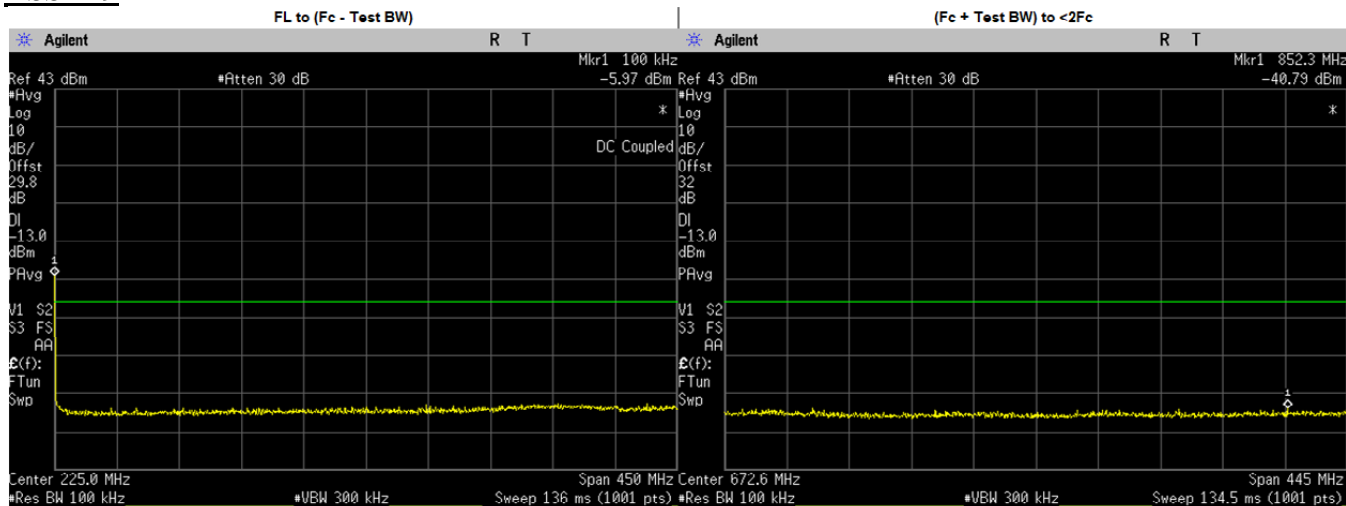

Frequency Range	Highest Spur Frequency (MHz)	Spurious Level (dBm)	Failing Limit (dBm)	Results
FL to (Fc - Test BW)	0.4590	-38.0900	-13.00	PASS
(Fc + Test BW) to <2Fc	852.3331	-40.7900	-13.00	PASS
2Fc to 1GHz	959.4893	-58.7200	-13.00	PASS
	900.0500	-61.3870	-13.00	PASS
1GHz to 10Fc	3068.0970	-50.4000	-13.00	PASS
	1350.0750	-54.8759	-13.00	PASS
	1800.1000	-54.3356	-13.00	PASS
	2250.1250	-54.0997	-13.00	PASS
	2700.1500	-53.5585	-13.00	PASS
	3150.1750	-50.8097	-13.00	PASS
	3600.2000	-52.2447	-13.00	PASS
	4050.2250	-51.9974	-13.00	PASS
4500.2500	-53.2055	-13.00	PASS	

**Analog: 450.025 MHz, 12.5kHz Channel Spacing, Max Power
 FCC Part 90,RSS 119**

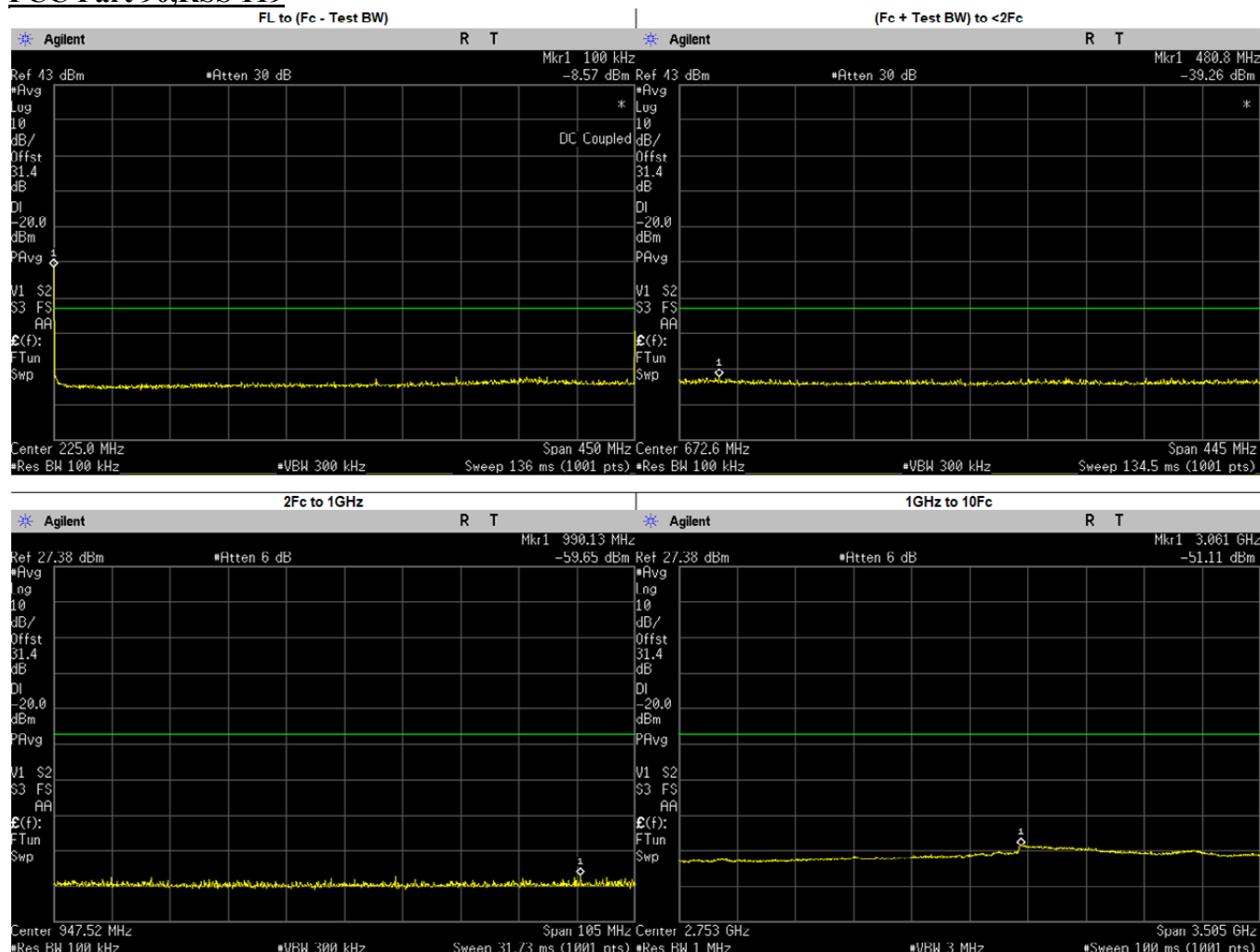

Frequency Range	Highest Spur Frequency (MHz)	Spurious Level (dBm)	Failing Limit (dBm)	Results
FL to (Fc - Test BW)	365.8258	-39.2378	-20.00	PASS
(Fc + Test BW) to <2Fc	480.7846	-39.2600	-20.00	PASS
2Fc to 1GHz	990.1347	-59.6500	-20.00	PASS
	900.0500	-61.4295	-20.00	PASS
1GHz to 10Fc	3061.0870	-51.1100	-20.00	PASS
	1350.0750	-55.4406	-20.00	PASS
	1800.1000	-54.9305	-20.00	PASS
	2250.1250	-54.7403	-20.00	PASS
	2700.1500	-54.1921	-20.00	PASS
	3150.1750	-51.6638	-20.00	PASS
	3600.2000	-52.9884	-20.00	PASS
	4050.2250	-52.7060	-20.00	PASS
4500.2500	-53.8158	-20.00	PASS	

**Analog: 450.025 MHz, 12.5kHz Channel Spacing, Low Power
 FCC Part 90,RSS 119**

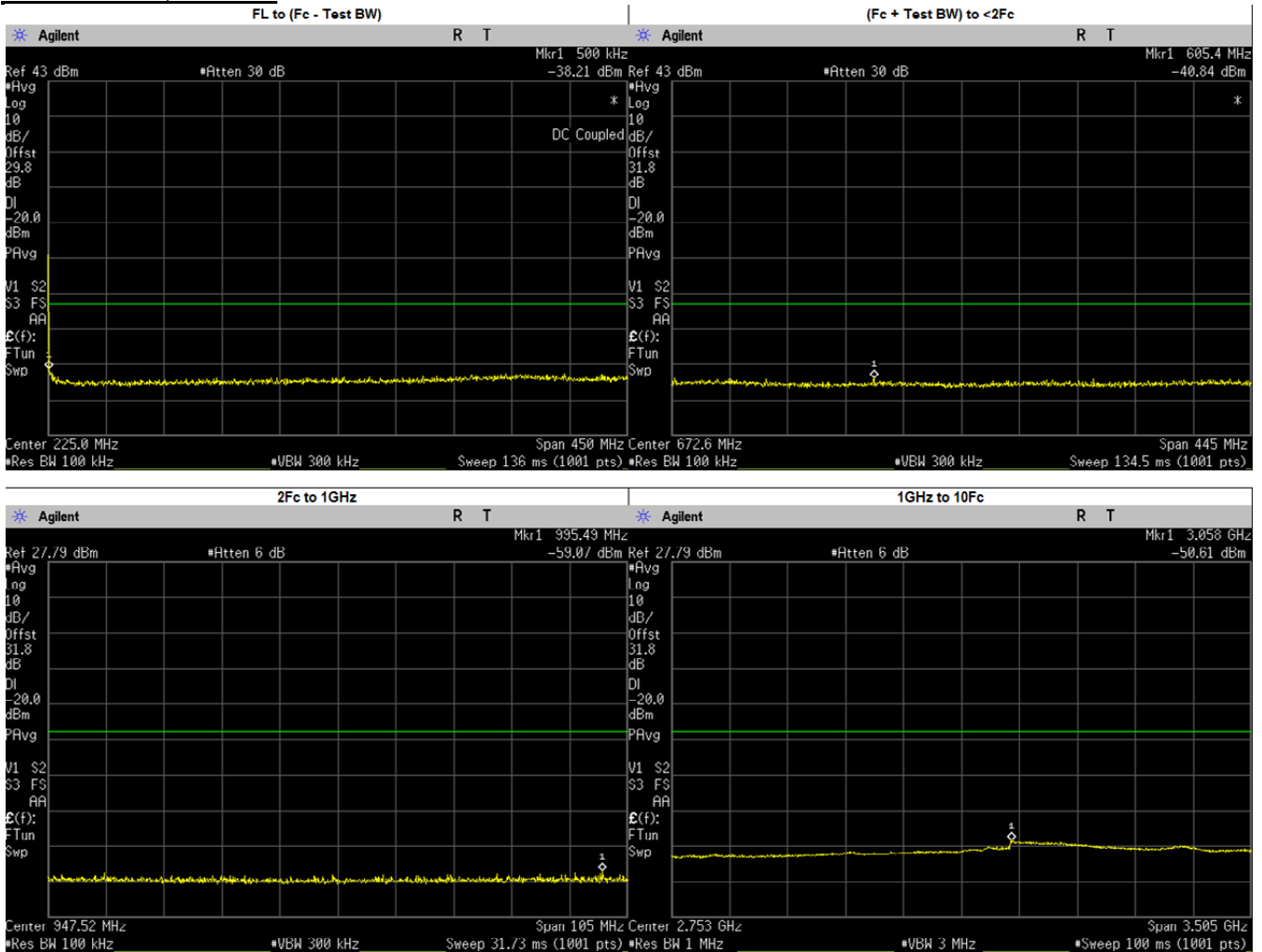

Frequency Range	Highest Spur Frequency (MHz)	Spurious Level (dBm)	Failing Limit (dBm)	Results
FL to (Fc - Test BW)	0.4590	-38.2835	-20.00	PASS
(Fc + Test BW) to <2Fc	605.3757	-40.8400	-20.00	PASS
2Fc to 1GHz	995.4872	-59.0700	-20.00	PASS
	900.0500	-61.4929	-20.00	PASS
1GHz to 10Fc	3057.5820	-50.6100	-20.00	PASS
	1350.0750	-54.7425	-20.00	PASS
	1800.1000	-54.8261	-20.00	PASS
	2250.1250	-54.4137	-20.00	PASS
	2700.1500	-53.6691	-20.00	PASS
	3150.1750	-51.1489	-20.00	PASS
	3600.2000	-52.5851	-20.00	PASS
	4050.2250	-52.4746	-20.00	PASS
	4500.2500	-53.3685	-20.00	PASS

**Analog: 459.125 MHz, 25.0kHz Channel Spacing, Max Power
 RSS 119**

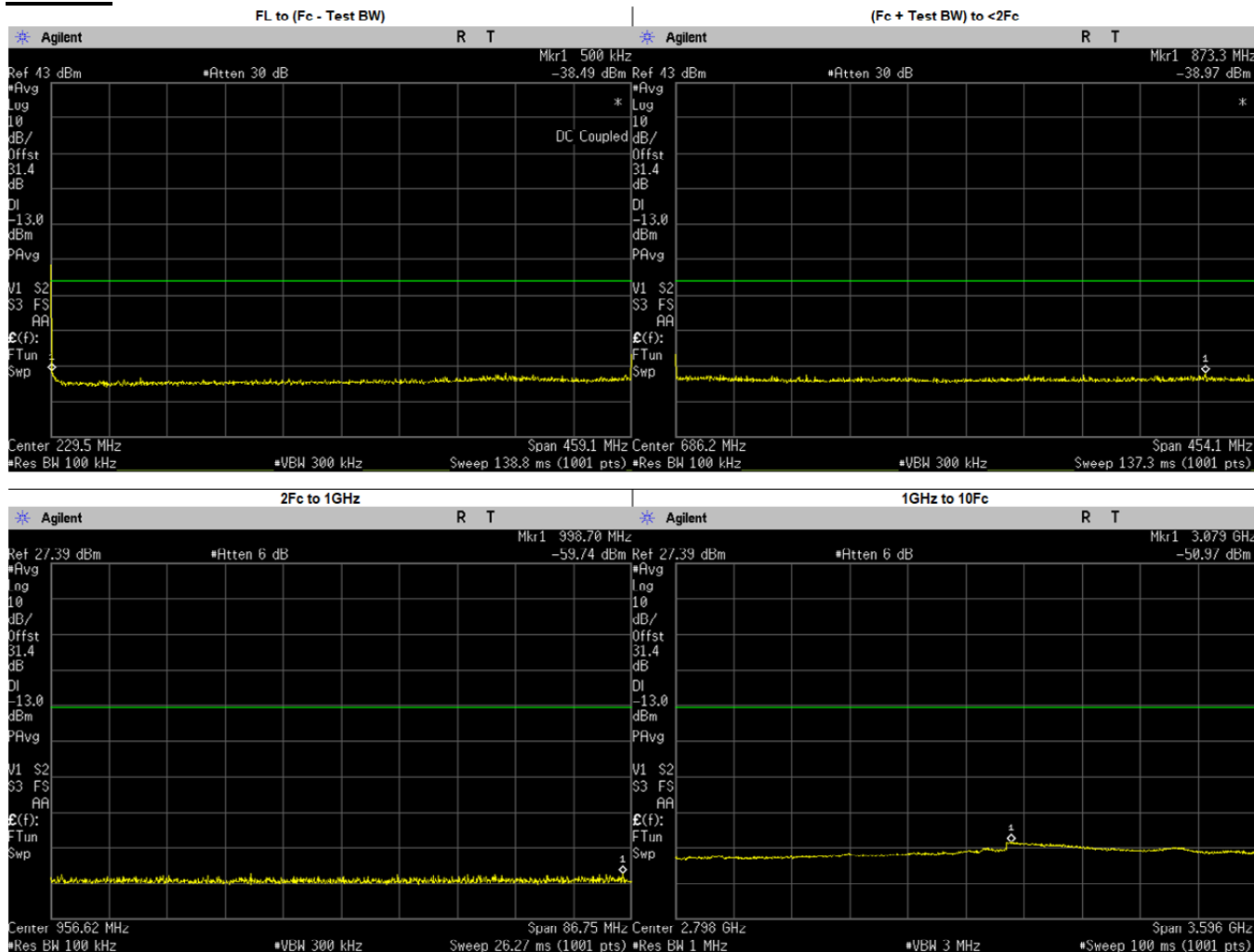

Frequency Range	Highest Spur Frequency (MHz)	Spurious Level (dBm)	Failing Limit (dBm)	Results
FL to (Fc - Test BW)	0.4681	-38.4900	-13.00	PASS
(Fc + Test BW) to <2Fc	873.2920	-38.9700	-13.00	PASS
2Fc to 1GHz	998.6988	-59.7400	-13.00	PASS
	918.2500	-61.4217	-13.00	PASS
1GHz to 10Fc	3078.6330	-50.9700	-13.00	PASS
	1377.3750	-55.2126	-13.00	PASS
	1836.5000	-55.1058	-13.00	PASS
	2295.6250	-54.6433	-13.00	PASS
	2754.7500	-53.7958	-13.00	PASS
	3213.8750	-51.6733	-13.00	PASS
	3673.0000	-53.1057	-13.00	PASS
	4132.1250	-52.7840	-13.00	PASS
4591.2500	-54.0669	-13.00	PASS	

**Analog: 459.125 MHz, 12.5kHz Channel Spacing, Max Power
 FCC Part 90, RSS 119**

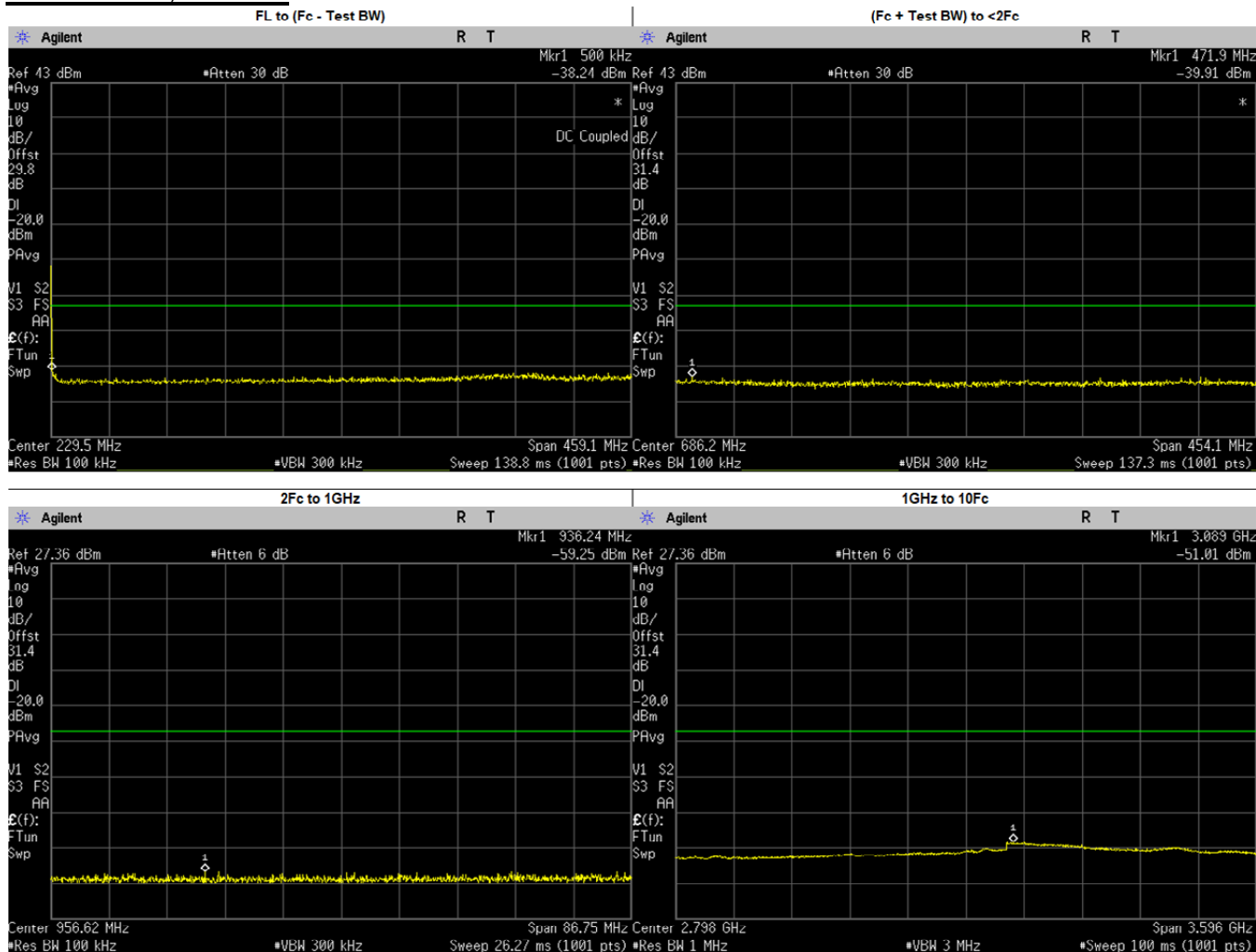

Frequency Range	Highest Spur Frequency (MHz)	Spurious Level (dBm)	Failing Limit (dBm)	Results
FL to (Fc - Test BW)	381.0281	-37.4558	-20.00	PASS
(Fc + Test BW) to <2Fc	471.9000	-39.9100	-20.00	PASS
2Fc to 1GHz	936.2387	-59.2500	-20.00	PASS
	918.2500	-61.7045	-20.00	PASS
1GHz to 10Fc	3089.4210	-51.0100	-20.00	PASS
	1377.3750	-55.4210	-20.00	PASS
	1836.5000	-55.0453	-20.00	PASS
	2295.6250	-54.8028	-20.00	PASS
	2754.7500	-54.0476	-20.00	PASS
	3213.8750	-51.5800	-20.00	PASS
	3673.0000	-52.9535	-20.00	PASS
	4132.1250	-52.7020	-20.00	PASS
	4591.2500	-54.2277	-20.00	PASS

**Analog: 469.9875 MHz, 25.0kHz Channel Spacing, Max Power
 RSS 119**

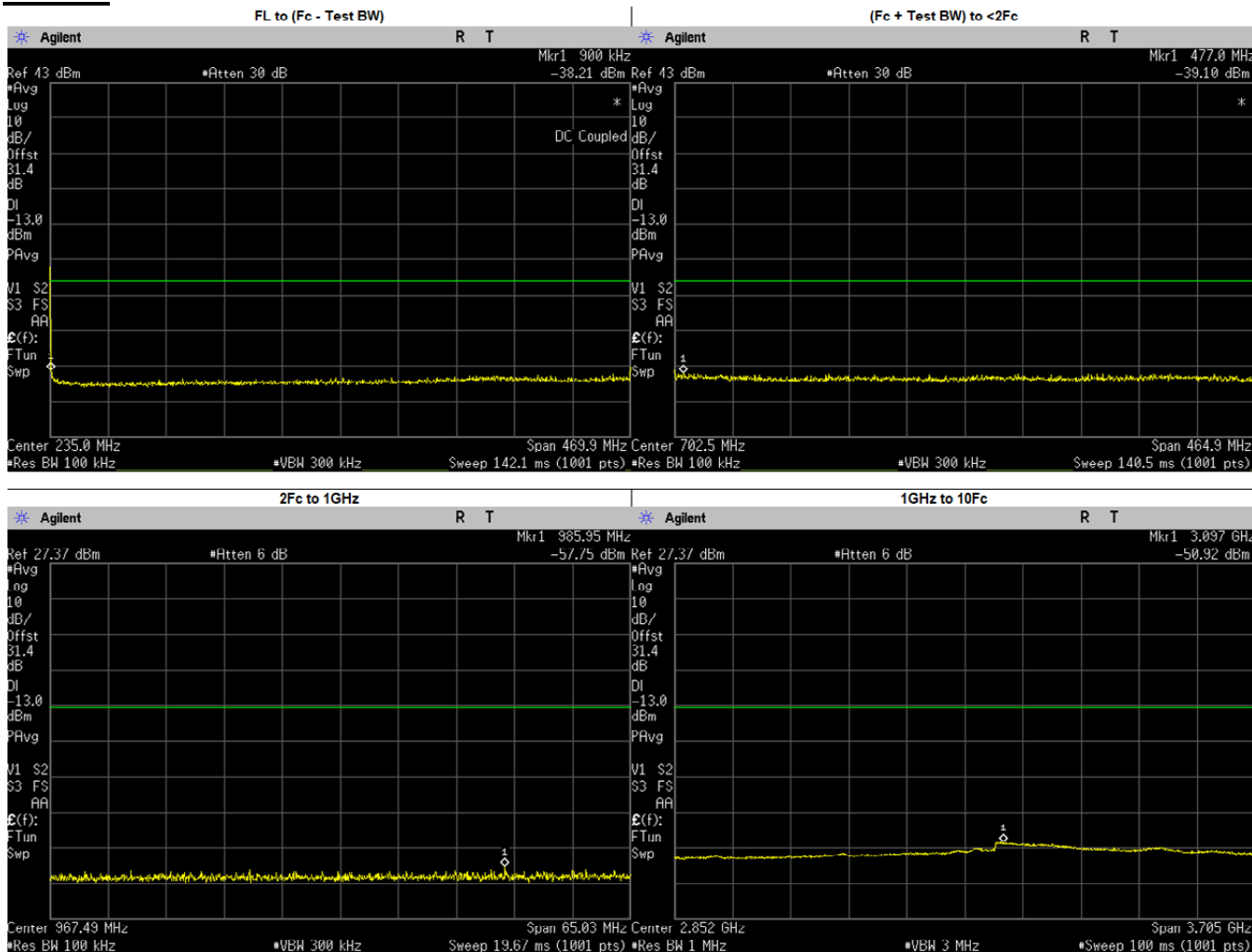

Frequency Range	Highest Spur Frequency (MHz)	Spurious Level (dBm)	Failing Limit (dBm)	Results
FL to (Fc - Test BW)	0.9488	-38.2100	-13.00	PASS
(Fc + Test BW) to <2Fc	477.0183	-39.1000	-13.00	PASS
2Fc to 1GHz	985.9546	-57.7500	-13.00	PASS
	939.9750	-61.2615	-13.00	PASS
1GHz to 10Fc	3096.9590	-50.9200	-13.00	PASS
	1409.9630	-55.4209	-13.00	PASS
	1879.9500	-55.1800	-13.00	PASS
	2349.9370	-54.3818	-13.00	PASS
	2819.9250	-53.3869	-13.00	PASS
	3289.9120	-51.6197	-13.00	PASS
	3759.9000	-52.8421	-13.00	PASS
	4229.8870	-53.3617	-13.00	PASS
	4699.8750	-54.1711	-13.00	PASS

**Analog: 469.9875 MHz, 12.5kHz Channel Spacing, Max Power
 FCC Part 90,RSS 119**

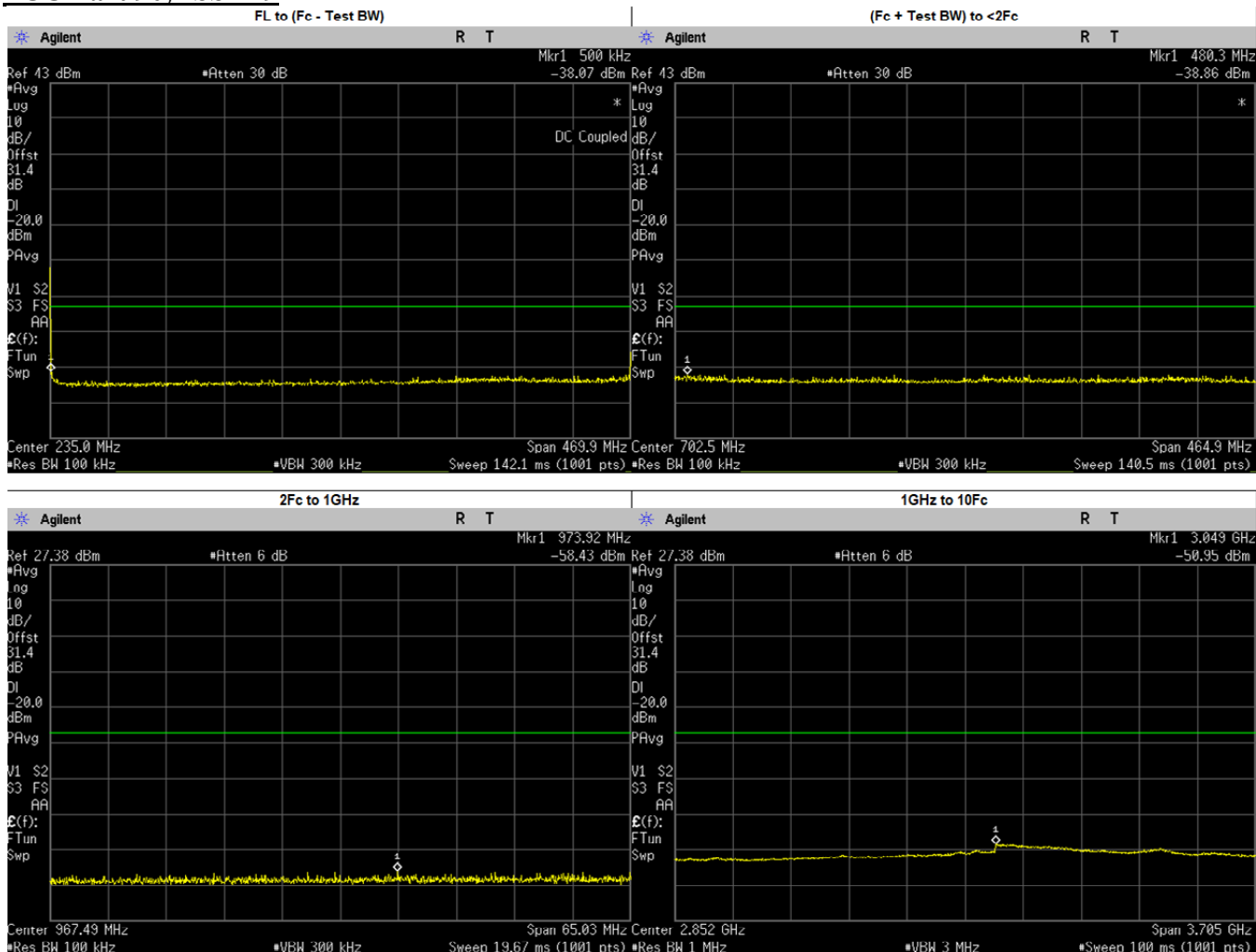

Frequency Range	Highest Spur Frequency (MHz)	Spurious Level (dBm)	Failing Limit (dBm)	Results
FL to (Fc - Test BW)	466.1713	-39.5071	-20.00	PASS
(Fc + Test BW) to <2Fc	480.2728	-38.8600	-20.00	PASS
2Fc to 1GHz	973.9250	-58.4300	-20.00	PASS
	939.9750	-61.5066	-20.00	PASS
1GHz to 10Fc	3048.7960	-50.9500	-20.00	PASS
	1409.9630	-55.4560	-20.00	PASS
	1879.9500	-55.0203	-20.00	PASS
	2349.9370	-54.5903	-20.00	PASS
	2819.9250	-53.3140	-20.00	PASS
	3289.9120	-52.0612	-20.00	PASS
	3759.9000	-53.0336	-20.00	PASS
	4229.8870	-53.5770	-20.00	PASS
	4699.8750	-54.3313	-20.00	PASS

6.10.3. Test Result (Digital)
Not Applicable

6.10.4. Test Limit

Table below summarized the power of any emission outside a licensee’s frequency block shall be attenuated below the transmitter power (P) by at least

Channel Spacing	Part 22	Part 24D	Part 74	Part 80	Part 90 (UHF, VHF, 800, 900)	Part 90 (700)
12.5kHz	43 + log10(P) (-13 dBm)	43 + log10(P) (-13 dBm)	43 + log10(P) (-13 dBm)	Not Applicable	50 + log10(P) (-20 dBm)	43 + log10(P) (-13 dBm)
25kHz		Not Applicable		43 + log10(P) (-13 dBm)	43 + log10(P) (-13 dBm)	43 + log10(P) (-13 dBm)

Channel Spacing	RSS 134	RSS 182	RSS 119 (UHF, VHF, 800, 900)	RSS 119 (700)
12.5kHz	43 + log10(P) (-13 dBm)	Not Applicable	50 + log10(P) (-20 dBm)	43 + log10(P) (-13 dBm)
25kHz	Not Applicable	43 + log10(P) (-13 dBm)	43 + log10(P) (-13 dBm)	43 + log10(P) (-13 dBm)

6.11. Radiated Spurious Emission

6.11.1. Test Setup

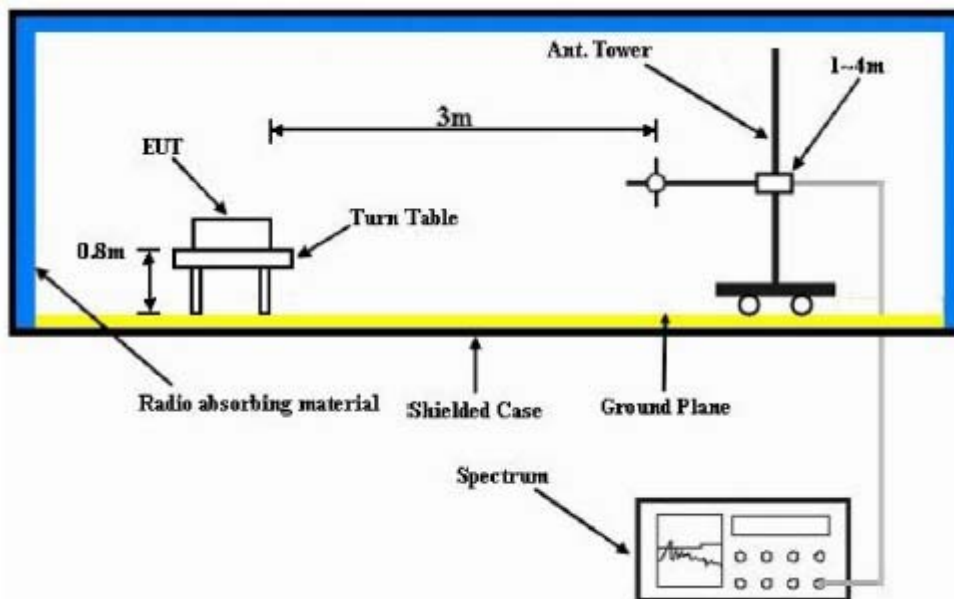

- 1) The Resolution Bandwidth for scanning Radiated Emission below 1 GHz is 100 kHz with Video Bandwidth = 300 kHz and Resolution Bandwidth for above 1 GHz is 1 MHz with Video Bandwidth = 3 MHz. Detector mode is positive peak.
- 2) In the semi- anechoic chamber, setup as illustrated above the DUT placed on the 0.8m height (for $F_c < 1\text{GHz}$) or 1.5m height (for $F_c > 1\text{GHz}$) of Turn Table, rotated the table around 360 degrees to search the maximum radiation power and receiver antenna shall be rotated vertical and horizontal polarization and moved height from 1m to 4m to find the maximum polar radiated power. The “Read Value” is the spectrum reading the maximum power value.
- 3) The substitution antenna is substituted for DUT at the same position and signals generator (S.G) export the CW signal to the substitution antenna via a TX cable. The receiver antenna shall be rotated vertical and horizontal polarization and moved height from 1m to 4m to find the maximum radiation power. Record the power level of maximum radiation power from spectrum. So, the measured substitution value = Ref level of S.G + TX cables loss – Substituted Antenna Gain.
- 4) Final Radiated Spurious Emission = “Read Value” + Measured substitution value.

6.11.2. Test Result (Analog)

SAC Transmitter Radiated Emission:
 Model Number: PMUE5521A S/N: 0095WA0298 SR:19112-EMC-00034
 Battery Part No: HKNN4013A Accy Part No: PMLN8064A, PMLN8077A-CF1
 Test Mode: TX Analog
 450.025000 MHz 12.5 kHz 0.500 Watt(s) /Low Power

Frequency (MHz)	Limit	Horizontal Measured Emission Equiv Pwr Into Ideal Dipole (dBm)	Vertical Measured Emission Equiv Pwr Into ideal Dipole (dBm)
900.0500	-20.0000	-85.5771 **	-87.5526 **
1350.0750	-20.0000	-61.1239 **	-59.7414 **
1800.1000	-20.0000	-59.8091 **	-59.3690 **
2250.1250	-20.0000	-57.2931 **	-55.6842 **
2700.1500	-20.0000	-54.5622 **	-54.5797 **
3150.1750	-20.0000	-52.9654 **	-50.9061 **
3600.2000	-20.0000	-51.9517 **	-52.1910 **
4050.2250	-20.0000	-50.5574 **	-49.5405 **
4500.2500	-20.0000	-51.4169 **	-50.4210 **

RADIATED SPURIOUS EMISSIONS

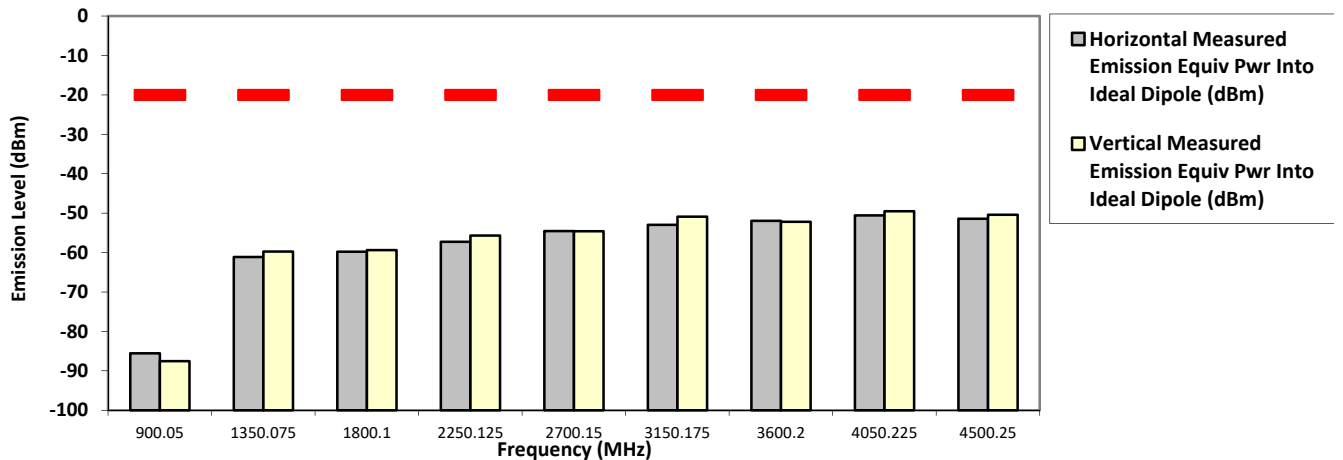

The data presented here was taken using the substitution method as found in the ANSI C63.26-2015 document.
 Motorola Penang EMC Lab - Test Performed by: Nazrin&Qawiman Sun, Feb 02, 2020

Remarks: ** Indicates the spurious emission could not be detected due to noise limitations or ambient.
 *Pursuant to CFR 47 Part 2.1057 (c), emissions attenuated more than 20 dB below the permissible limit are not reported
 Temp(Deg): 23.2 Hum(%RH): 69.3

System MU: 4.03 dB

Remarks:

Passed Results	Marginal Results	Failed Results
----------------	------------------	----------------

SAC Transmitter Radiated Emission:

Model Number: PMUE5521A **S/N: 0095WA0304** **SR:19112-EMC-00034**
Battery Part No: HKNN4013A **Accy Part No: PMLN8064A, PMLN8077A-CF1**

450.025000 MHz **Test Mode: TX Analog** **1.350 Watt(s) /Max Power**
12.5 kHz

Frequency (MHz)	Limit	Horizontal Measured Emission Equip Pwr Into Ideal Dipole (dBm)	Vertical Measured Emission Equip Pwr Into ideal Dipole (dBm)
900.0500	-20.0000	-87.2067 **	-86.1691 **
1350.0750	-20.0000	-61.6076 **	-61.0207 **
1800.1000	-20.0000	-58.8770 **	-58.6789 **
2250.1250	-20.0000	-55.8709 **	-56.9449 **
2700.1500	-20.0000	-54.0280 **	-54.3533 **
3150.1750	-20.0000	-53.0304 **	-52.4100 **
3600.2000	-20.0000	-51.4122 **	-51.7412 **
4050.2250	-20.0000	-49.2754 **	-51.3637 **
4500.2500	-20.0000	-50.4688 **	-50.3512 **

RADIATED SPURIOUS EMISSIONS

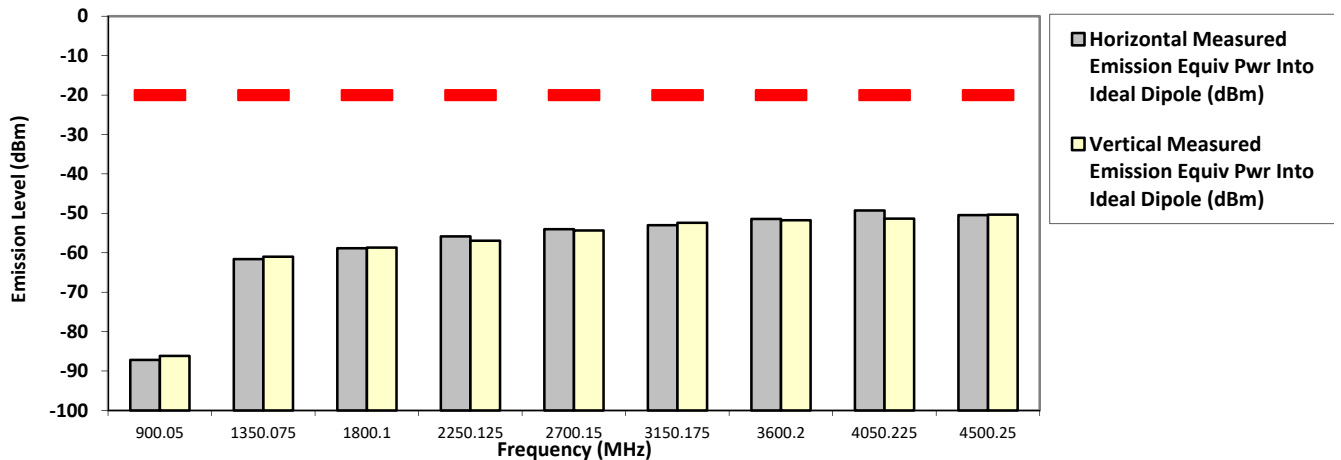

The data presented here was taken using the substitution method as found in the ANSI C63.26-2015 document.
 Motorola Penang EMC Lab - Test Performed by: Nazrin&Qawiman Sun, Feb 02, 2020

Remarks: ** Indicates the spurious emission could not be detected due to noise limitations or ambient.
 *Pursuant to CFR 47 Part 2.1057 (c), emissions attenuated more than 20 dB below the permissible limit are not reported
 Temp(Deg): 23.2 Hum(%RH): 69.3

System MU: 4.03 dB

Remarks:	Passed Results	Marginal Results	Failed Results
-----------------	----------------	------------------	----------------

SAC Transmitter Radiated Emission:
Model Number: PMUE5521A S/N: 0095WA0298 SR:19112-EMC-00034
Battery Part No: HKNN4013A Accy Part No: PMLN8064A, PMLN8077A-CF1
450.025000 MHz Test Mode: TX Analog 25 kHz 0.500 Watt(s) /Low Power

Frequency (MHz)	Limit	Horizontal Measured Emission Equiv Pwr Into Ideal Dipole (dBm)	Vertical Measured Emission Equiv Pwr Into ideal Dipole (dBm)
900.0500	-13.0000	-85.5525 **	-87.7848 **
1350.0750	-13.0000	-59.8744 **	-57.8100 **
1800.1000	-13.0000	-58.9112 **	-59.4531 **
2250.1250	-13.0000	-57.8389 **	-56.8384 **
2700.1500	-13.0000	-55.0258 **	-55.1123 **
3150.1750	-13.0000	-51.5793 **	-52.6139 **
3600.2000	-13.0000	-51.7405 **	-52.3017 **
4050.2250	-13.0000	-50.8090 **	-50.7613 **
4500.2500	-13.0000	-50.6952 **	-49.9032 **

RADIATED SPURIOUS EMISSIONS

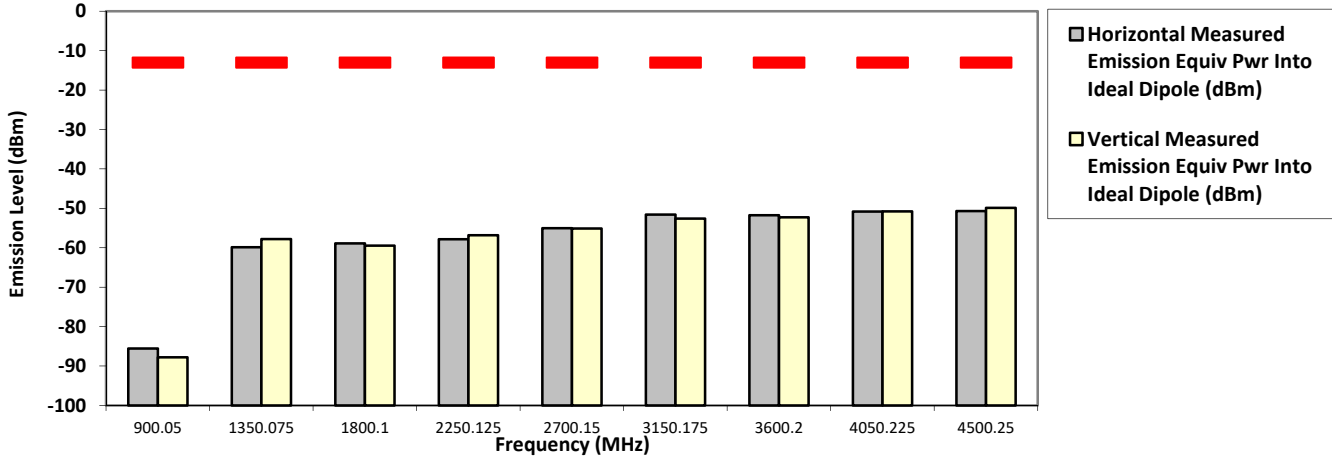

The data presented here was taken using the substitution method as found in the ANSI C63.26-2015 document.
Motorola Penang EMC Lab - Test Performed by: Nazrin&Qawiman Sun, Feb 02, 2020

Remarks: ** Indicates the spurious emission could not be detected due to noise limitations or ambient.

*Pursuant to CFR 47 Part 2.1057 (c), emissions attenuated more than 20 dB below the permissible limit are not reported
Temp(Deg): 23.2 Hum(%RH): 69.3

System MU: 4.03 dB

Remarks: Passed Results Marginal Results Failed Results

SAC Transmitter Radiated Emission:

Model Number: PMUE5521A
 Battery Part No: HKNN4013A

S/N: 0095WA0304

SR:19112-EMC-00034

Accy Part No: PMLN8064A, PMLN8077A-CF1

Test Mode: TX Analog
 25 kHz

450.025000 MHz

1.350 Watt(s) /Max Power

Frequency (MHz)	Limit	Horizontal Measured Emission Equiv Pwr Into Ideal Dipole (dBm)	Vertical Measured Emission Equiv Pwr Into ideal Dipole (dBm)
900.0500	-13.0000	-87.2552 **	-85.4341 **
1350.0750	-13.0000	-57.2800 *	-49.7400 *
1800.1000	-13.0000	-59.9990 **	-58.3465 **
2250.1250	-13.0000	-47.1900 *	-52.6100 *
2700.1500	-13.0000	-54.8272 **	-53.6288 **
3150.1750	-13.0000	-51.9296 **	-52.8405 **
3600.2000	-13.0000	-52.9334 **	-52.1540 **
4050.2250	-13.0000	-51.1723 **	-50.9139 **
4500.2500	-13.0000	-50.8163 **	-49.0376 **

RADIATED SPURIOUS EMISSIONS

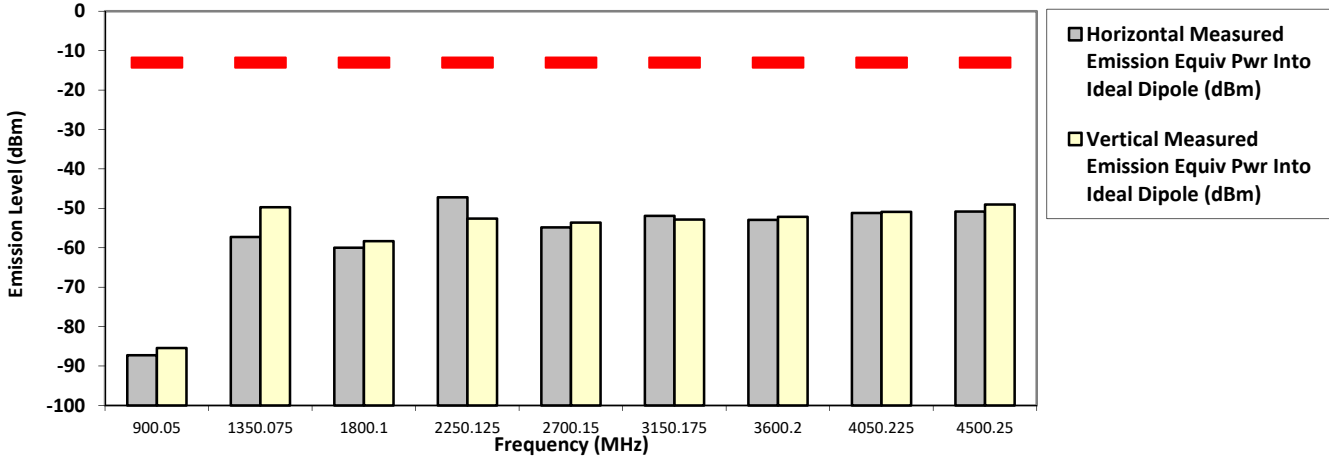

The data presented here was taken using the substitution method as found in the ANSI C63.26-2015 document.
 Motorola Penang EMC Lab - Test Performed by: Nazrin&Qawiman Sun, Feb 02, 2020

Remarks: ** Indicates the spurious emission could not be detected due to noise limitations or ambient.
 *Pursuant to CFR 47 Part 2.1057 (c), emissions attenuated more than 20 dB below the permissible limit are not reported
 Temp(Deg): 23.2 Hum(%RH): 69.3

System MU: 4.03 dB

Remarks:	Passed Results	Marginal Results	Failed Results
----------	----------------	------------------	----------------

SAC Transmitter Radiated Emission:

Model Number: PMUE5521A
 Battery Part No: HKNN4013A

S/N: 0095WA0298

SR:19112-EMC-00034

Accy Part No: PMLN8064A, PMLN8077A-CF1

459.125000 MHz

Test Mode: TX Analog
 12.5 kHz

0.500 Watt(s) /Low Power

Frequency (MHz)	Limit	Horizontal Measured Emission Equip Pwr Into Ideal Dipole (dBm)	Vertical Measured Emission Equip Pwr Into ideal Dipole (dBm)
918.2500	-20.0000	-85.1425 **	-86.2465 **
1377.3750	-20.0000	-59.9563 **	-59.2425 **
1836.5000	-20.0000	-58.2004 **	-58.4680 **
2295.6250	-20.0000	-55.9182 **	-56.7448 **
2754.7500	-20.0000	-53.7965 **	-55.5623 **
3213.8750	-20.0000	-52.1754 **	-51.8413 **
3673.0000	-20.0000	-52.0646 **	-52.1031 **
4132.1250	-20.0000	-51.6340 **	-51.2962 **
4591.2500	-20.0000	-50.2465 **	-49.2789 **

RADIATED SPURIOUS EMISSIONS

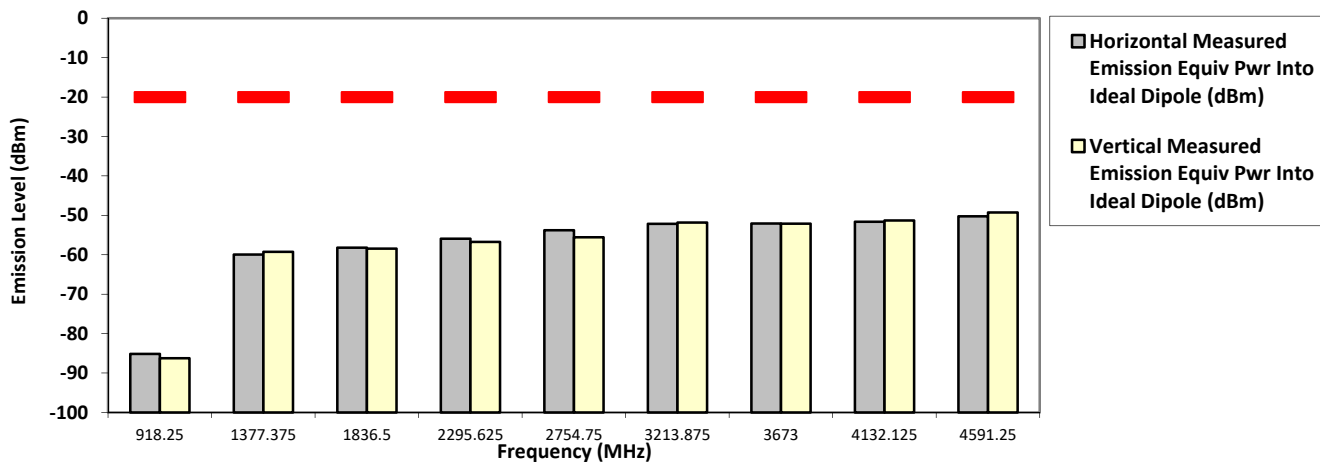

The data presented here was taken using the substitution method as found in the ANSI C63.26-2015 document.
 Motorola Penang EMC Lab - Test Performed by: Nazrin&Qawiman Sun, Feb 02, 2020

Remarks: ** Indicates the spurious emission could not be detected due to noise limitations or ambient.
 *Pursuant to CFR 47 Part 2.1057 (c), emissions attenuated more than 20 dB below the permissible limit are not reported
 Temp(Deg): 23.2 Hum(%RH): 69.3

System MU: 4.03 dB

Remarks: Passed Results Marginal Results Failed Results

SAC Transmitter Radiated Emission:

Model Number: PMUE5521A S/N: 0095WA0304 SR:19112-EMC-00034
 Battery Part No: HKNN4013A Accy Part No: PMLN8064A, PMLN8077A-CF1
 459.125000 MHz Test Mode: TX Analog 1.350 Watt(s) /Max Power
 12.5 kHz

Frequency (MHz)	Limit	Horizontal Measured Emission Equiv Pwr Into Ideal Dipole (dBm)	Vertical Measured Emission Equiv Pwr Into ideal Dipole (dBm)
918.2500	-20.0000	-85.7973 **	-84.8193 **
1377.3750	-20.0000	-61.3811 **	-58.7754 **
1836.5000	-20.0000	-59.0164 **	-58.9917 **
2295.6250	-20.0000	-56.5881 **	-57.2803 **
2754.7500	-20.0000	-55.0669 **	-55.0468 **
3213.8750	-20.0000	-51.4787 **	-52.9238 **
3673.0000	-20.0000	-52.9436 **	-52.3265 **
4132.1250	-20.0000	-50.7152 **	-51.1532 **
4591.2500	-20.0000	-50.5262 **	-49.9147 **

RADIATED SPURIOUS EMISSIONS

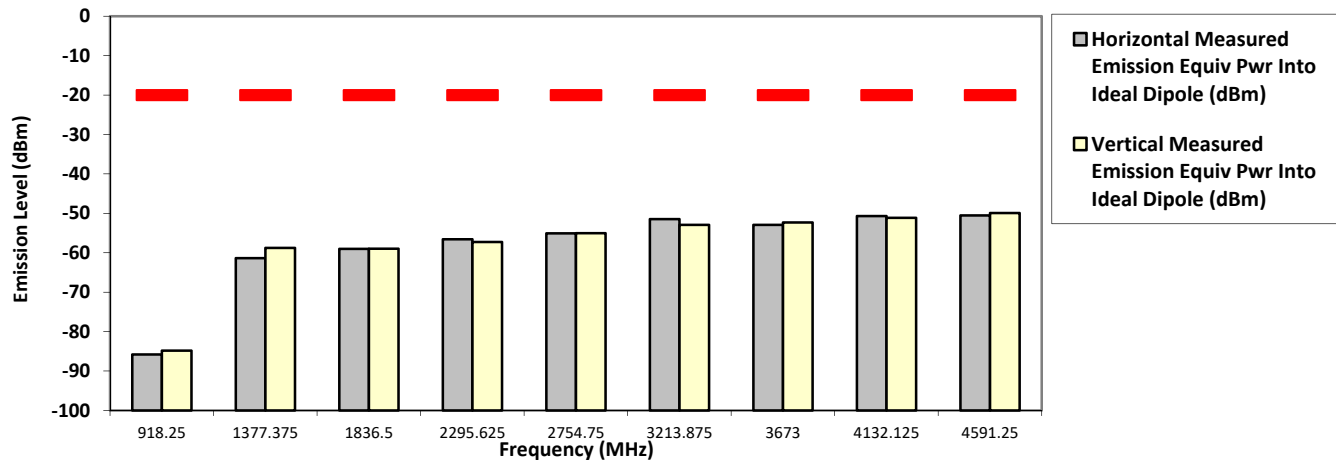

The data presented here was taken using the substitution method as found in the ANSI C63.26-2015 document.
 Motorola Penang EMC Lab - Test Performed by: Nazrin&Qawiman Sun, Feb 02, 2020

Remarks: ** Indicates the spurious emission could not be detected due to noise limitations or ambient.
 *Pursuant to CFR 47 Part 2.1057 (c), emissions attenuated more than 20 dB below the permissible limit are not reported
 Temp(Deg): 23.2 Hum(%RH): 69.3

System MU: 4.03 dB

Remarks: Passed Results Marginal Results Failed Results

SAC Transmitter Radiated Emission:

Model Number: PMUE5521A
 Battery Part No: HKNN4013A

S/N: 0095WA0298
 Accy Part No: PMLN8064A, PMLN8077A-CF1

459.125000 MHz

Test Mode: TX Analog
 25 kHz

0.500 Watt(s) /Low Power

Frequency (MHz)	Limit	Horizontal Measured Emission Equiv Pwr Into Ideal Dipole (dBm)	Vertical Measured Emission Equiv Pwr Into ideal Dipole (dBm)
918.2500	-13.0000	-87.1276 **	-85.8118 **
1377.3750	-13.0000	-60.9060 **	-59.2970 **
1836.5000	-13.0000	-58.0381 **	-59.2477 **
2295.6250	-13.0000	-57.2711 **	-56.3560 **
2754.7500	-13.0000	-55.2618 **	-55.5827 **
3213.8750	-13.0000	-52.3359 **	-52.1196 **
3673.0000	-13.0000	-51.8161 **	-52.5605 **
4132.1250	-13.0000	-51.4266 **	-51.5186 **
4591.2500	-13.0000	-48.7971 **	-51.1347 **

RADIATED SPURIOUS EMISSIONS

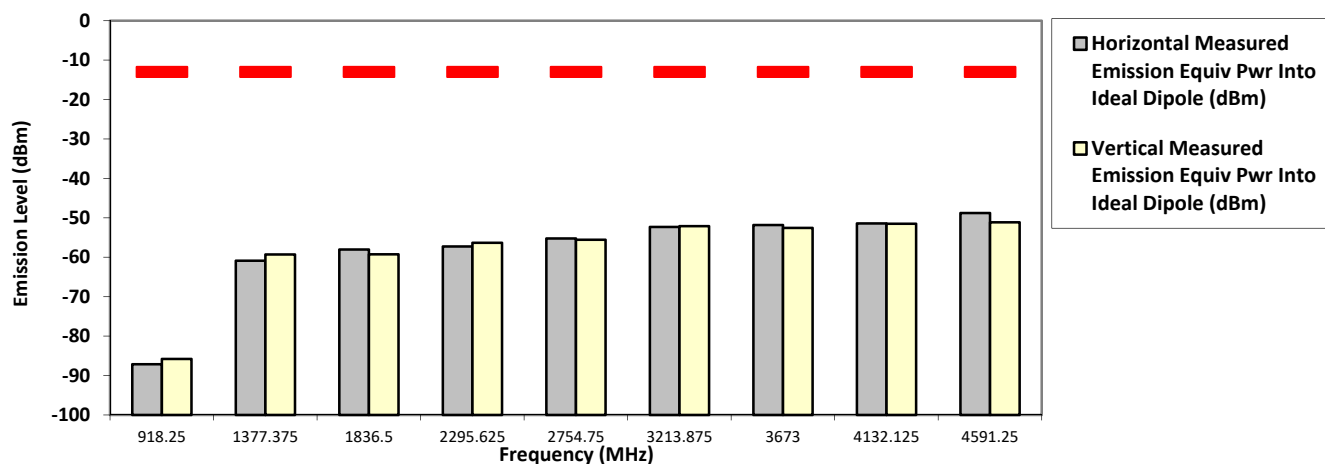

The data presented here was taken using the substitution method as found in the ANSI C63.26-2015 document.
 Motorola Penang EMC Lab - Test Performed by: Nazrin&Qawiman Sun, Feb 02, 2020

Remarks: ** Indicates the spurious emission could not be detected due to noise limitations or ambient.
 *Pursuant to CFR 47 Part 2.1057 (c), emissions attenuated more than 20 dB below the permissible limit are not reported
 Temp(Deg): 23.2 Hum(%RH): 69.3

System MU: 4.03 dB

Remarks: Passed Results Marginal Results Failed Results

SAC Transmitter Radiated Emission:

Model Number: PMUE5521A S/N: 0095WA0304 SR:19112-EMC-00034
 Battery Part No: HKNN4013A Accy Part No: PMLN8064A, PMLN8077A-CF1
 Test Mode: TX Analog
 459.125000 MHz 25 kHz 1.350 Watt(s) /Max Power

Frequency (MHz)	Limit	Horizontal Measured Emission Equip Pwr Into Ideal Dipole (dBm)	Vertical Measured Emission Equip Pwr Into ideal Dipole (dBm)
918.2500	-13.0000	-86.3055 **	-85.7503 **
1377.3750	-13.0000	-60.5379 **	-60.3921 **
1836.5000	-13.0000	-59.3697 **	-59.2819 **
2295.6250	-13.0000	-57.3932 **	-56.4450 **
2754.7500	-13.0000	-54.6176 **	-55.4348 **
3213.8750	-13.0000	-52.0004 **	-52.1190 **
3673.0000	-13.0000	-52.2317 **	-51.7519 **
4132.1250	-13.0000	-50.2143 **	-51.6956 **
4591.2500	-13.0000	-50.4573 **	-49.1963 **

RADIATED SPURIOUS EMISSIONS

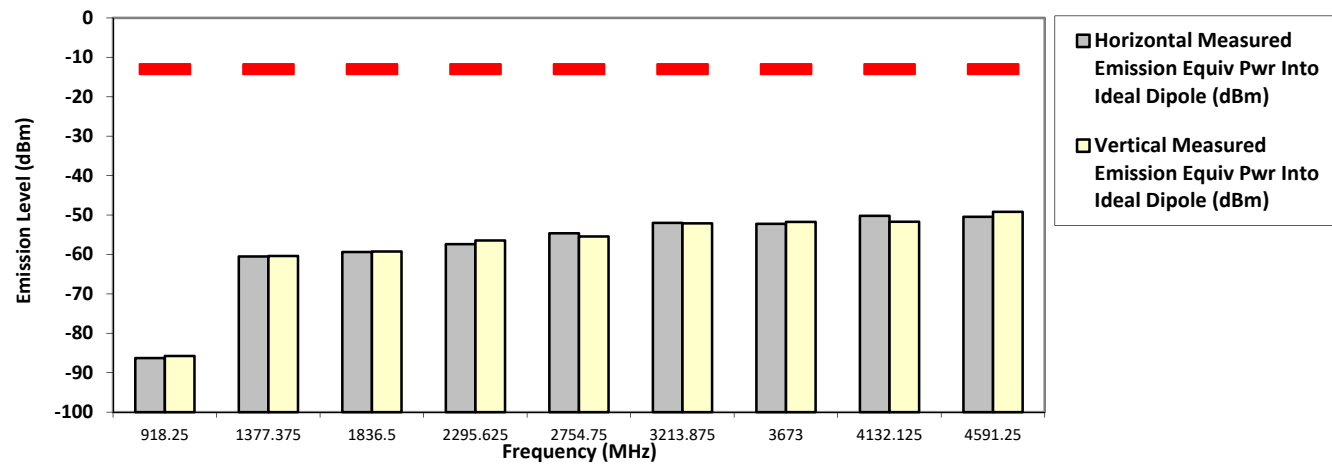

The data presented here was taken using the substitution method as found in the ANSI C63.26-2015 document.
 Motorola Penang EMC Lab – Test Performed by: Nazrin&Qawiman Sun, Feb 02, 2020

Remarks: ** Indicates the spurious emission could not be detected due to noise limitations or ambient.
 *Pursuant to CFR 47 Part 2.1057 (c), emissions attenuated more than 20 dB below the permissible limit are not reported
 Temp(Deg): 23.2 Hum(%RH): 69.3

System MU: 4.03 dB

Remarks:

Passed Results	Marginal Results	Failed Results
----------------	------------------	----------------

SAC Transmitter Radiated Emission:
Model Number: PMUE5521A **S/N: 0095WA0304** **SR:19112-EMC-00034**
Battery Part No: HKNN4013A **Accy Part No: PMLN8064A, PMLN8077A-CF1**
469.987500 MHz **Test Mode: TX Analog** **12.5 kHz** **1.350 Watt(s) /Max Power**

Frequency (MHz)	Limit	Horizontal Measured Emission Equiv Pwr Into Ideal Dipole (dBm)	Vertical Measured Emission Equiv Pwr Into ideal Dipole (dBm)
939.9750	-20.0000	-85.2566 **	-84.8384 **
1409.9625	-20.0000	-49.6700 *	-46.1800 *
1879.9500	-20.0000	-59.4357 **	-58.6860 **
2349.9375	-20.0000	-54.3366 **	-55.7935 **
2819.9250	-20.0000	-54.9236 **	-54.6123 **
3289.9125	-20.0000	-52.4993 **	-52.0416 **
3759.9000	-20.0000	-51.4680 **	-52.3318 **
4229.8875	-20.0000	-51.0287 **	-50.8243 **
4699.8750	-20.0000	-48.2284 **	-49.7540 **

RADIATED SPURIOUS EMISSIONS

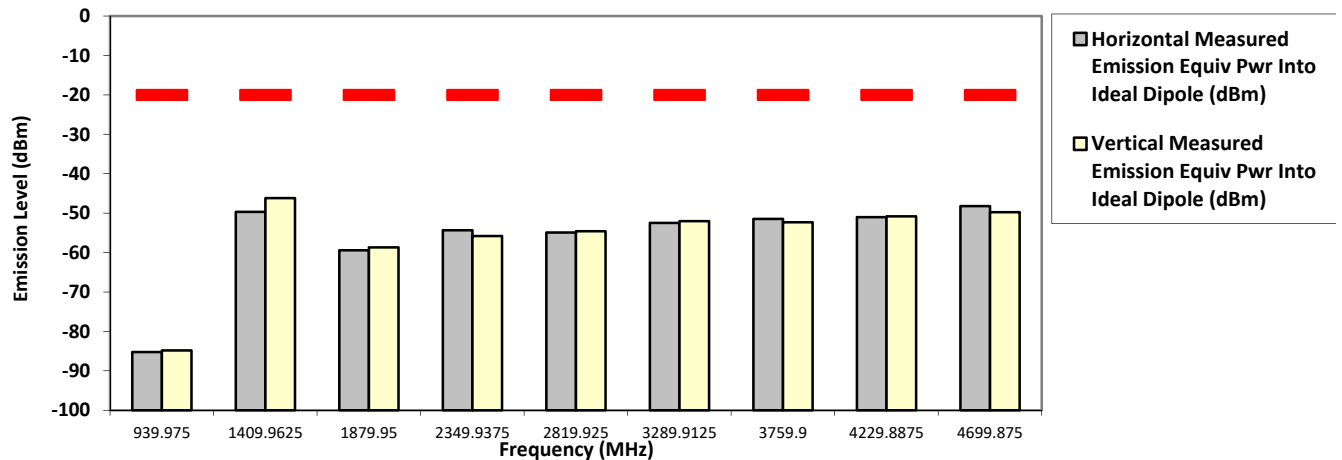

The data presented here was taken using the substitution method as found in the ANSI C63.26-2015 document.
 Motorola Penang EMC Lab - Test Performed by: Nazrin&Qawiman Sun, Feb 02, 2020

Remarks: ** Indicates the spurious emission could not be detected due to noise limitations or ambient.
 *Pursuant to CFR 47 Part 2.1057 (c), emissions attenuated more than 20 dB below the permissible limit are not reported
 Temp(Deg): 23.2 Hum(%RH): 69.3

System MU: 4.03 dB

Remarks:	Passed Results	Marginal Results	Failed Results
----------	----------------	------------------	----------------

Model Number: **PMUE5521A**
 Battery Part No: **HKNN4013A**

SAC Transmitter Radiated Emission:
 S/N: **0095WA0304**

SR:**19112-EMC-00034**

Accy Part No: **PMLN8064A, PMLN8077A-CF1**

Test Mode: **TX Analog**
25 kHz

469.987500 MHz

1.350 Watt(s) /Max Power

Frequency (MHz)	Limit	Horizontal Measured Emission Equip Pwr Into Ideal Dipole (dBm)	Vertical Measured Emission Equip Pwr Into ideal Dipole (dBm)
939.9750	-13.0000	-85.0281 **	-86.4081 **
1409.9625	-13.0000	-52.6300 *	-46.5300 *
1879.9500	-13.0000	-58.0854 **	-58.3551 **
2349.9375	-13.0000	-54.3173 **	-55.2002 **
2819.9250	-13.0000	-54.8727 **	-54.8615 **
3289.9125	-13.0000	-52.4049 **	-52.7519 **
3759.9000	-13.0000	-52.3721 **	-51.9379 **
4229.8875	-13.0000	-51.1814 **	-51.2466 **
4699.8750	-13.0000	-48.3582 **	-48.7814 **

RADIATED SPURIOUS EMISSIONS

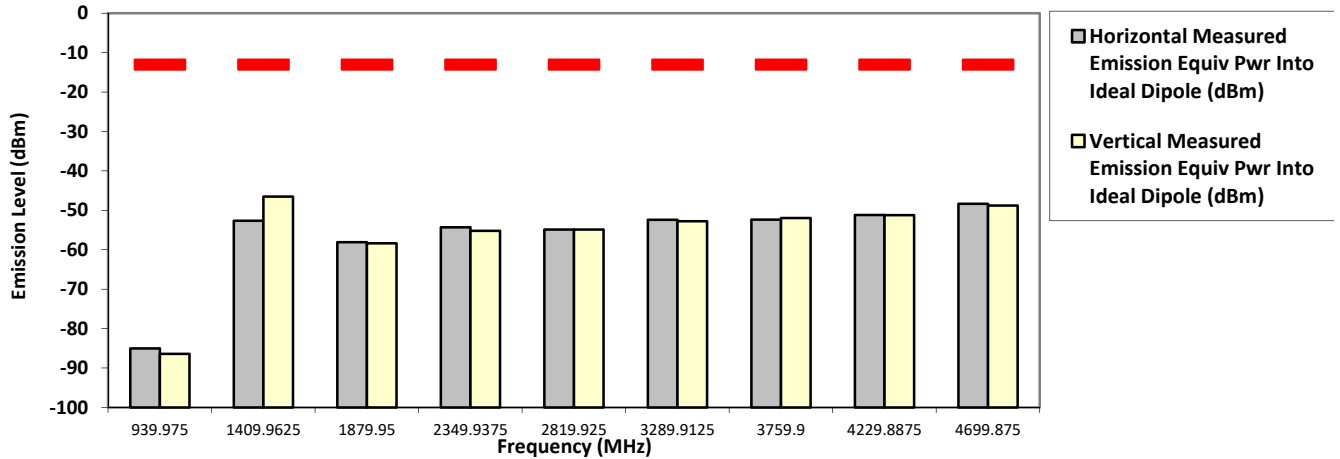

The data presented here was taken using the substitution method as found in the ANSI C63.26-2015 document.
 Motorola Penang EMC Lab - Test Performed by: Nazrin&Qawiman Sun, Feb 02, 2020

Remarks: ** Indicates the spurious emission could not be detected due to noise limitations or ambient.
 *Pursuant to CFR 47 Part 2.1057 (c), emissions attenuated more than 20 dB below the permissible limit are not reported
 Temp(Deg): 23.2 Hum(%RH): 69.3

System MU: 4.03 dB

Remarks: Passed Results Marginal Results Failed Results

6.11.3. Test Result (Digital)
Not Applicable

6.11.4. Test Limit

Table below summarized the power of any emission outside a licensee’s frequency block shall be attenuated below the transmitter power (P) by at least

Channel Spacing	Part 22	Part 24D	Part 74	Part 80	Part 90 (UHF, VHF, 800, 900)	Part 90 (700)
12.5kHz	43 + log ₁₀ (P) (-13 dBm)	43 + log ₁₀ (P) (-13 dBm)	43 + log ₁₀ (P) (-13 dBm)	Not Applicable	50 + log ₁₀ (P) (-20 dBm)	43 + log ₁₀ (P) (-13 dBm)
25kHz		Not Applicable		43 + log ₁₀ (P) (-13 dBm)	43 + log ₁₀ (P) (-13 dBm)	43 + log ₁₀ (P) (-13 dBm)

Channel Spacing	RSS 134	RSS 182	RSS 119 (UHF, VHF, 800, 900)	RSS 119 (700)
12.5kHz	43 + log ₁₀ (P) (-13 dBm)	Not Applicable	50 + log ₁₀ (P) (-20 dBm)	43 + log ₁₀ (P) (-13 dBm)
25kHz	Not Applicable	43 + log ₁₀ (P) (-13 dBm)	43 + log ₁₀ (P) (-13 dBm)	43 + log ₁₀ (P) (-13 dBm)

6.12. Effective Radiated Power (ERP)

6.12.1. Test Setup

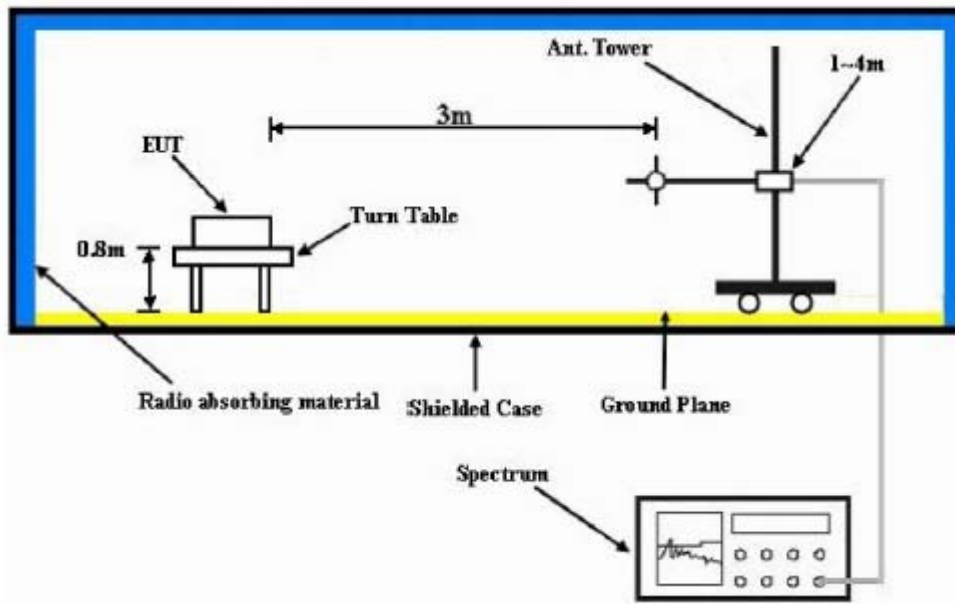

- 1) The Resolution Bandwidth for Equivalent Radiated Power (ERP) below 1 GHz is 100 kHz with Video Bandwidth = 300 kHz and Resolution Bandwidth for EIRP above 1 GHz is 1 MHz with Video Bandwidth = 3 MHz. Detector Mode is RMS.
- 2) In the semi-anechoic chamber, setup as illustrated above the DUT placed on the 0.8m height (for $f_c < 1\text{GHz}$) or 1.5m (for $f_c > 1\text{GHz}$) of Turn Table, rotated the table 45 degree each interval to search the maximum radiation power and receiver antenna shall be rotated vertical and horizontal polarization and moved height from 1m to 4m to find the maximum polar radiated power for each degree interval. The “Read Value” is the spectrum reading of maximum power value.
- 3) The substitution antenna is substituted for DUT at the same position and signals generator (S.G) export the CW signal to the substitution antenna via a TX cable. The receiver antenna shall be rotated vertical and horizontal polarization and moved height from 1m to 4m to find the maximum radiation power. Record the power level of maximum radiation power from spectrum. So, the Measured substitution value = Ref level of S.G + TX cables loss – Substituted Antenna Gain.

6.12.2. Test Result
Not Applicable

6.12.3. Test Limit
The maximum output power of the transmitter for mobile stations is 100 watts (20 dB).
Power is given in terms of effective radiated power (ERP).

6.13. GNSS (EIRP for 1559 - 1610MHz)

6.13.1. Test Setup

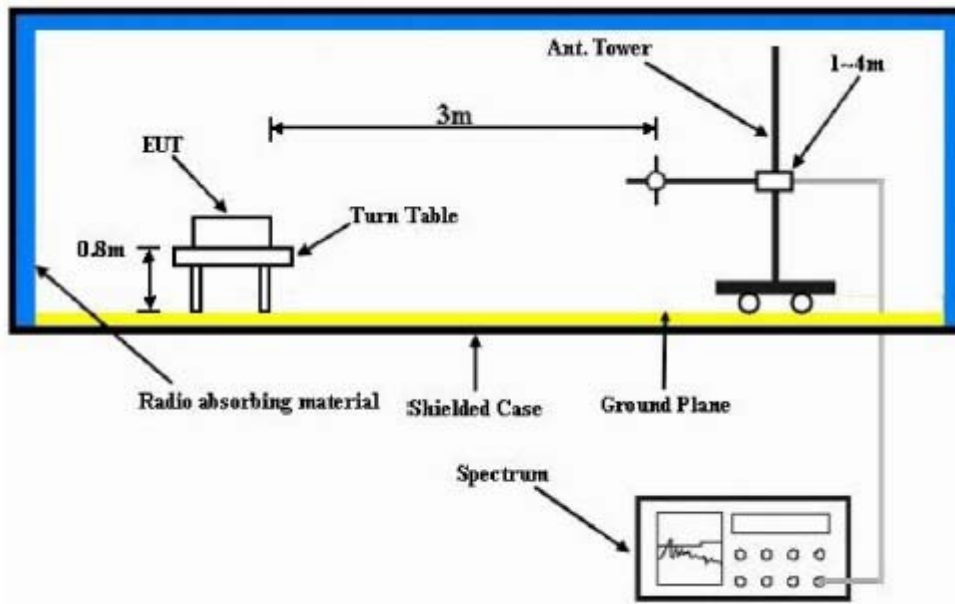

- 1) The Resolution Bandwidth for Equivalent Isotropically Radiated Power (EIRP) below 1 GHz is 100 kHz with Video Bandwidth = 300 kHz and Resolution Bandwidth for EIRP above 1 GHz is 1 MHz with Video Bandwidth = 3 MHz. Detector Mode is RMS.
- 2) In the semi-anechoic chamber, setup as illustrated above the DUT placed on the 0.8m height of Turn Table, rotated the table 45 degree each interval to search the maximum radiation power and receiver antenna shall be rotated vertical and horizontal polarization and moved height from 1m to 4m to find the maximum polar radiated power for each degree interval. The “Read Value” is the spectrum reading of maximum power value.
- 3) The substitution antenna is substituted for DUT at the same position and signals generator (S.G) export the CW signal to the substitution antenna via a TX cable. The receiver antenna shall be rotated vertical and horizontal polarization and moved height from 1m to 4m to find the maximum radiation power. Record the power level of maximum radiation power from spectrum. So, the Measured substitution value = Ref level of S.G + TX cables loss – Substituted Antenna Gain.
- 4) $EIRP = \text{“Read Value”} + \text{Measured substitution value} + 2.15$.

6.13.1. Test Result
Not Applicable

6.13.2. Test Limit

For operations in the 758-775 MHz and 788-805 MHz bands, all emissions including harmonics in the band 1559-1610 MHz shall be limited to -70 dBW/MHz equivalent isotropically radiated power (EIRP) for wideband signals, and -80 dBW EIRP for discrete emissions of less than 700 Hz bandwidth.

~ End of Test Report ~