

 MOTOROLA SOLUTIONS	 MS ISO/IEC 17025 TESTING SAMM No. 0825
---	--

<p>MOTOROLA PENANG ADV. COMM. LABORATORY Motorola Solutions Malaysia Sdn Bhd Innoplex Plot 2A, Medan Bayan Lepas, Mukim 12 S.W.D, 11900 Bayan Lepas, Penang, Malaysia.</p>	<p>FCC / ISED TEST REPORT Report Revision : Rev.B</p>
---	--

<p>Date/s Tested : 8-JUL-2019 - 17-JUL-2019 Report Issue Date : 24-JUL-2019 Manufacturer/Location : Motorola Solutions Malaysia Sdn Bhd Requestor : ONG POH KHOON Product Type : Portable Model Number : VX-80-G6-4 Frequency Band : 400 – 470MHz Low / Max RF Output Power : 1Watts /4.8Watts Application Name : Motorola Solutions Inc Manufacturer Address : Plot 2, Bayan Lepas Technoplex, 11900 Bayan Lepas, Penang, Malaysia ISED Registrations : 109AK FCC Registrations : 461337 Firmware Version : T001.016</p>			
<p>The equipment was tested accordance to the requirement listed below:</p> <table style="width: 100%; border-collapse: collapse;"> <tr> <td style="width: 60%;"> <p>(LMR) FCC 47 CFR Part 90 ISED RSS119</p> </td> <td style="width: 40%; text-align: center; vertical-align: middle;"> <p>PASS</p> </td> </tr> </table>		<p>(LMR) FCC 47 CFR Part 90 ISED RSS119</p>	<p>PASS</p>
<p>(LMR) FCC 47 CFR Part 90 ISED RSS119</p>	<p>PASS</p>		

This report shall not be reproduced without written approval from an officially designated representative of the Motorola Penang Adv. Comm. Laboratory. The results and statements contained in this report pertain only to the device(s) evaluated.

Prepared By: <hr style="width: 200px; margin-left: 0;"/> <p>Tan Sze Khai Test Personnel</p>	Approved By: <hr style="width: 200px; margin-left: 0;"/> <p>Vincent Foong Chuen Kit Deputy Technical Manager</p>
---	--

Table of Contents

Report Revision History	3
1.0 General Information	4
2.0 Summary of Test Results	5
3.0 Measurement Uncertainty	6
4.0 Equipment List.....	6
5.0 Test Condition	9
5.1. Transmitter Test Conditions	9
6.0 Transmitter Test Parameters	10
6.1. RF Output Power	10
6.1.1. Test Setup.....	10
6.1.2. Test Result.....	10
6.2. Frequency Stability	11
6.2.1. Test Setup.....	11
6.2.2. Test Result.....	12
6.2.3. Test Limit.....	13
6.3. Audio Frequency Response	14
6.3.1. Test Setup.....	14
6.3.2. Test Result.....	15
6.3.3. Test Limit.....	17
6.4. Audio Low Pass Filter Response	18
6.4.1. Test Setup.....	18
6.4.2. Test Result.....	18
6.4.3. Test Limit.....	19
6.5. Modulation Limiting	20
6.5.1. Test Setup.....	20
6.5.2. Test Result.....	21
6.5.3. Test Limit.....	22
6.6. Occupied Bandwidth.....	23
6.6.1. Test Setup (Analog).....	23
6.6.2. Test Result (Analog).....	24
6.6.3. Test Setup (Digital)	28
6.6.4. Test Result (Digital)	28
6.6.5. Test Limit.....	28
6.7. Band Edge Conducted Spurious Emission (Part 22).....	29
6.7.1. Test Setup (Analog).....	29
6.7.2. Test Result (Analog).....	29
6.7.3. Test Setup (Digital)	30
6.7.4. Test Result (Digital)	30
6.7.5. Test Limit.....	30
6.8. Transient Frequency Behavior.....	31
6.8.1. Test Setup.....	31
6.8.2. Test Result.....	32
6.8.3. Test Limit.....	34

6.9. Adjacent Channel Power 35

 6.9.1. Test Setup (Analog)..... 35

 6.9.2. Test Result(Analog)..... 35

 NA → Not Applicable 35

 6.9.3. Test Setup (Digital) 36

 6.9.4. Test Result (Digital) 36

 NA → Not Applicable 36

 6.9.5. Test limit 37

6.10. Conducted Spurious Emission 39

 6.10.1. Test Setup..... 39

 6.10.2. Test Result (Analog)..... 40

 6.10.3. Test Result (Digital) 60

 NA → Not Applicable 60

 6.10.4. Test Limit..... 60

6.11. Radiated Spurious Emission 61

 6.11.1. Test Setup..... 61

 6.11.1. Test Result (Analog) NA → Not Applicable..... 62

 6.11.2. Test Limit..... 82

6.12. Effective Radiated Power (ERP)..... 83

 6.12.1. Test Setup..... 83

 6.12.2. Test Result..... 83

 6.12.3. Test Limit..... 83

6.13. GNSS (EIRP for 1559 - 1610MHz)..... 84

 6.13.1. Test Setup..... 84

 6.13.1. Test Result..... 84

 6.13.2. Test Limit..... 85

Report Revision History

Revision History	Description	Date	Originator
Rev. A	Initial Report	17-JUL-2019	Tan Sze Khai
Rev. B	Update calibration due dates on FCC Analog ATE#1	13-AUG-2019	Tan Sze Khai

1.0 General Information

EUT Description:

Technologies	Land Mobile Radio (LMR)
Modulation Type	Analog

General Description of Applied Standards

The EUT is a RF Product. According to the specifications of the manufacturer, the EUT is to comply with the requirements of the following standards:

ANSI C63.4-2014

ANSI C63.26-2015

2.0 Summary of Test Results

FCC General Rules Part (47CFR)	ISED General Rules Part	Test Item	Result	Remark
2.1046,90.541(700MHz),22.565,74.461,74.534,80.215, Part90	RSS-119	RF Power Output	Pass	-
2.1055, 90.213, 22.355	RSS-119	Frequency Stability	Pass	-
2.1047, 74.463, 80.213	RSS-119	Audio Frequency Response	NA	-
-	RSS-119	Audio Low Pass Filter Response	NA	-
2.1047, 74.463, 80.213	RSS-119	Modulation limiting	NA	-
2.1049, 90.210, 22.359, 74.462, 74.535	RSS-119	Occupied Bandwidth	NA	16K0F3E – 15.0294 11K0F3E – 9.9778
-	-	Band Edge Conducted Spurious Emission	NA	-
90.214	-	Transient Frequency Behavior	NA	-
-	-	Adjacent Channel Power	NA	-
2.1053,90.210	RSS-119	Conducted Spurious Emissions	Pass	Highest Spur Level -37.12dBm
2.1053,90.210	RSS-119	Radiated Spurious Emission	Pass	Highest Radiated Emission Level -35.25dBm
-	-	GNSS (EIRP for 1559 – 1610MHz)	NA	-
-	-	Effective Radiated Power (ERP)	NA	-

NA → Not Applicable

3.0 Measurement Uncertainty

Measurement	Frequency	Expanded Uncertainty (k=1.96) (±)
AC Power Line Conducted Spurious Emission	150KHz ~ 30MHz	3.43
Radiated Emissions up to 1 GHz	30MHz ~ 200MHz	5.01
	200MHz ~ 1000MHz	5.01
Radiated Emissions above 1 GHz	1GHz ~ 18GHz	5.01
	18GHz ~ 25GHz	5.01

4.0 Equipment List

FCC Analog ATE#1: (SW version: 2.4.5 & FCC_Frequency Stability 1.0.3 rev.)

Description	Model	Serial Number	Calibration Date	Calibration Due Date
Audio Analyzer	8903B	3729A17612	15-Nov-17	15-Nov-20
SIGNAL GENERATOR	2042	203002/747	22-Jan-19	22-Jan-20
MODULATION ANALYZER	8901B	3538A05696	4-Apr-19	4-Apr-20
DSA	36570A	MY42506781	5-Aug-19	5-Aug-20
POWER SENSOR	E9031A	MY41502652	19-Nov-18	19-Nov-19
POWER SUPPLY	6623A	2916A01562	31-Mar-19	31-Mar-20
POWER METER	E4416A	GB41293747	11-Apr-19	11-Apr-20
CHAMBER	SH-641	92009188	29-Mar-19	29-Mar-20
N to N RF Cable # 1	M17/128-RG400	NA	NA	NA
BNC to N RF Cable # 1	RG 58	NA	NA	NA
BNC to BNC RF Cable # 1	RG 58	NA	NA	NA
BNC to BNC RF Cable # 2	RG 58	NA	NA	NA
BNC to BNC RF Cable # 3	RG 58	NA	NA	NA
BNC to BNC RF Cable # 4	RG 58	NA	NA	NA
BNC to BNC RF Cable # 5	RG 58	NA	NA	NA
BNC to BNC RF Cable # 6	RG 58	NA	NA	NA
BNC to BNC RF Cable # 7	RG 58	NA	NA	NA
N to SMA RF Cable # 1	RG 58	NA	NA	NA
N to SMA RF Cable # 2	RG 58	NA	NA	NA
N to SMA RF Cable # 3	RG 58	NA	NA	NA
Aeroflex Attenuator 30dB	49-30-34-LIM	NA	NA	NA

FCC Transient ATE #1: (SW version: FCC Transient ATE_R1.1.2)

Description	Model	Serial Number	Calibration Date	Calibration Due Date
POWER SUPPLY	6032A	2818A03549	11-Jul-19	11-Jul-20
POWER SENSOR	E4412A	MY41498918	29-Jul-18	29-Jul-19
POWER METER	E4416A	GB41293866	26-Feb-19	26-Feb-21
ATTENUATORS/SWITCH DRIVER	11713A	2508A10141	CNR	CNR
STEP ATTENUATOR/11dB	8494G	MY52300223	26-Jul-18	26-Jul-19
STEP ATTENUATOR/110dB	8496G	MY52300176	26-Jul-18	26-Jul-19
OSCILLOSCOPE	MSO8104A	MY45002372	17-Jun-19	17-Jun-20
AUDIO ANALYZER	8903B	3729A17409	18-Jul-19	18-Jul-20
AUDIO ANALYZER	8903B	3413A14586	7-Jul-19	7-Jul-20
MODULATION ANALYZER	8901B	3616A03889	9-Jul-19	9-Jul-20
SIGNAL GENERATOR	8657A	3039A3205	5-Jul-19	5-Jul-20
SPECTRUM ANALYZER	E4440A	MY46185415	16-Aug-17	16-Aug-19
N to N RF Cable # 1	SF126/11N/11N	NA	NA	NA
N to N RF Cable # 2	M17/128-RG400	NA	NA	NA
N to N RF Cable # 3	M17/128-RG400	NA	NA	NA
N to N RF Cable # 4	M17/128-RG400	NA	NA	NA
N to N RF Cable # 5	M17/128-RG400	NA	NA	NA
N to N RF Cable # 6	M17/128-RG400	NA	NA	NA
N to N RF Cable # 7	M17/128-RG400	NA	NA	NA
N to N RF Cable # 8	M17/128-RG400	NA	NA	NA
N to N RF Cable # 9	M17/128-RG400	NA	NA	NA
BNC to BNC RF Cable # 1	RG 58	NA	NA	NA
BNC to BNC RF Cable # 2	RG 58	NA	NA	NA
BNC to BNC RF Cable # 3	RG 58	NA	NA	NA
BNC to BNC RF Cable # 4	RG 58	NA	NA	NA
BNC to BNC RF Cable # 5	RG 58	NA	NA	NA
BNC to BNC RF Cable # 6	RG 58	NA	NA	NA
BNC to N RF Cable # 1	RG 58	NA	NA	NA
Aeroflex Attenuator 10dB	49-10-43-LIM	NA	NA	NA
Aeroflex Attenuator 10dB	33-10-34-LIM	NA	NA	NA
SWITCH CONTROL UNIT	3488A	2719A36210	CNR	CNR

CONDUCTED SPUR EMISSION ATE # 1 (SW version: Conducted Spur ATE_rev 1.23.02)

Description	Model	Serial Number	Calibration Date	Calibration Due Date
SWITCH CONTROL UNIT	3488A	2719A32735	CNR	CNR
PSA Series Spectrum Analyzer	E4445A	MY46181732	12-Mar-19	12-Mar-21
POWER SUPPLY	6032A	MY41002067	11-Jul-19	11-Jul-20
HIGH PASS FILTER SWITCH BOX	-	CS001	4-Jul-19	4-Jul-20
N to N RF Cable # 1	SF126/11N/11N	NA	NA	NA
N to N RF Cable # 2	SF126/11N/11N	NA	NA	NA
BNC to BNC RF Cable # 1	RG 58	NA	NA	NA
Aeroflex Attenuator 30dB	49-30-43-LIM	NA	NA	NA
Aeroflex Attenuator 10dB	33-10-34-LIM	NA	NA	NA

Radiated Emission

Description	Model #	Serial Number	Calibration Date	Calibration Due Date
EMI TEST RECEIVER	ESIB26	100017	11-Jul-18	11-Oct-19 (Cal ext)
3m Semi-anechoic Chamber	NA	888032	No Cal. Req'd	No Cal. Req'd
TURNTABLE FLUSH MOUNT 2M	T-200-S	N/A	No Cal. Req'd	No Cal. Req'd
Bore sight Antenna mast	MBS-500	N/A	No Cal. Req'd	No Cal. Req'd
PROGRAMMING CONTROLLER	3000	MF7802082 72	No Cal. Req'd	No Cal. Req'd
POWER SUPPLY	6674A	3126A- 00133	07-Nov-17	07-Nov-19
SIGNAL ANALYZER	FSV40	101103	03-Jul-18	03-Oct-19
DATA LOGGER	SDL500	A.016776	05-Apr-19	05-Apr-20
BILOG ANTENNA	CBL6112D	25224	01-Aug-18	01-Aug-19
DRG HORN FREQ.	SAS-571	566	27-Sep-17	27-Sep-19
PREAMPLIFIER	PAM-0118	427	No Cal. Req'd	No Cal. Req'd
MICROWAVE GENERATOR	SMP04	100146	11-Jul-19	11-Jul-20
DRG HORN FREQ.	SAS-571	1143	14-Feb-19	14-Feb-21
BILOG ANTENNA	CBL6112B	2964	16-Feb-18	16-Feb-20
Test Software	EMC FCC IC Bluetooth RE Test			
Version	EMC FCC RE v1.5.2			

CNR → Calibration Not Require

5.0 Test Condition

5.1. Transmitter Test Conditions

Test Item, (Channel Spacing)	Power (W)	Modulation	Test Frequency (MHz)	Tested By
RF Output Power	Low & Max	Analog	400.0125,406.2, 450.025,459.125, 467.775,469.9875	TAN SZE KHAI
Frequency Stability	Max	Analog	467.775	TAN SZE KHAI
Audio Frequency Response (12.5kHz / 25kHz)	Max	Analog	467.775,459.125	TAN SZE KHAI
Audio Low Pass Filter Response (12.5kHz / 25kHz)	Max	Analog	NA	NA
Modulation limiting (12.5kHz / 25kHz)	Max	Analog	467.775,459.125	TAN SZE KHAI
Occupied Bandwidth (12.5kHz / 25kHz)	Max	Analog	400.0125,406.2, 450.025,469.9875	TAN SZE KHAI
Band Edge Conducted Spurious Emissions (Part 22) (12.5kHz / 20kHz / 25kHz)	Max	Analog	NA	NA
Transient Frequency Behavior (UHF & VHF Band) (12.5kHz / 25kHz)	Max	Analog	467.775	TAN SZE KHAI
Adjacent Channel Power (700MHz Band) (12.5kHz)	Max	Analog	NA	NA
Conducted Spurious Emissions- (12.5kHz / 25kHz)	Low / Max	Analog	400.0125,406.2, 450.025,459.125, 467.775,469.9875	TAN SZE KHAI
Radiated Spurious Emission (12.5kHz / 25kHz)	Low / Max	Analog	NA	NA
GNSS (EIRP for 1559 - 1610MHz) (12.5kHz / 25kHz)	Max	Analog	NA	NA
Effective Radiated Power (ERP) (12.5kHz / 25kHz)	Max	Analog	NA	NA

NA → Not Applicable

6.0 Transmitter Test Parameters

6.1 RF Output Power

6.1.1 Test Setup

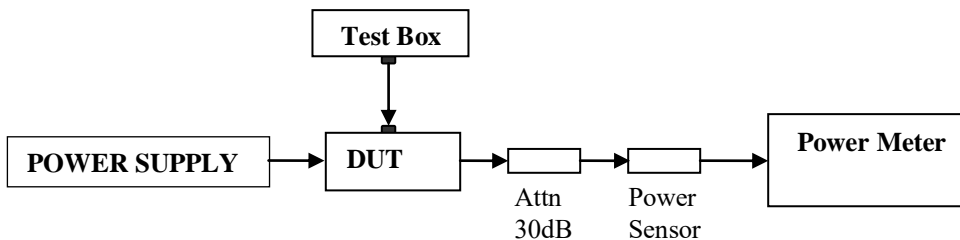

- 1) The DUT transmitter connected to Power Meter using the 30 dB attenuator and power sensor with above setup.
- 2) Path loss for the measurement included.
- 3) All the measurement was done at low, mid, high frequency for each band.
- 4) Record the power into the test report.

6.1.2 Test Result

Temperature	25°C				Remarks
Voltage (V)	7.2V				
Frequency (MHz)	Low Power (W)	Current (A)	Max Power (W)	Current (A)	
400.0125	1.05	0.51	4.64	1.08	
406.2	0.98	0.54	4.69	1.11	
450.025	0.99	0.57	4.66	1.32	
459.125	1.02	0.57	4.68	1.23	
467.775	1.02	0.51	4.7	1.17	
469.9875	1.02	0.55	4.68	1.17	

6.2. Frequency Stability

6.2.1. Test Setup

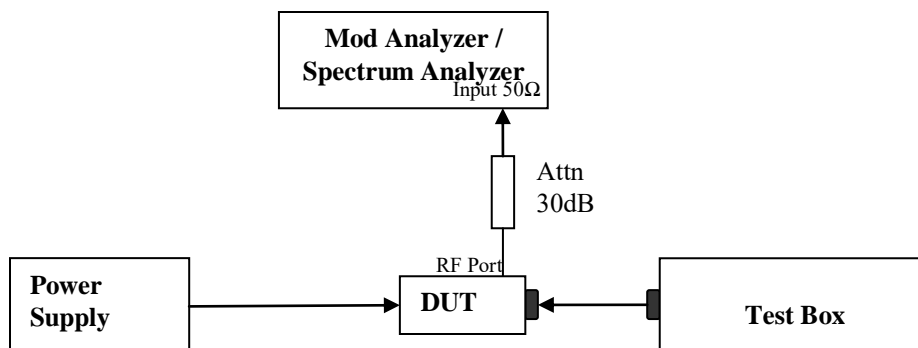

- 1) The DUT transmitter output port was connected to Modulation / Spectrum Analyzer.
- 2) Path loss for the measurement included.
- 3) Transmit the DUT and record the freq in MCF_{MHz} .
- 4) Test in 2 conditions:
 - Temperature: The frequency of the transmitter was measured from -30°C to 50°C.
 - Supply Voltage:
 - Mobile: The frequency of the transmitter was measured from 85% to 115% of the nominal operating input voltage.
 - Portable: The frequency of the transmitter was measured from nominal $\pm x$ % as specified by the manufacturer
- 5) Calculate the ppm frequency error by the following:

$$ppm\ error = \left(\frac{MCF_{MHz}}{ACF_{MHz}} - 1 \right) * 10^6$$

Where: MCF_{MHz} is the Measured Carrier Frequency in MHz
 ACF_{MHz} is the Assigned Carrier Frequency in MHz

6.2.2. Test Result

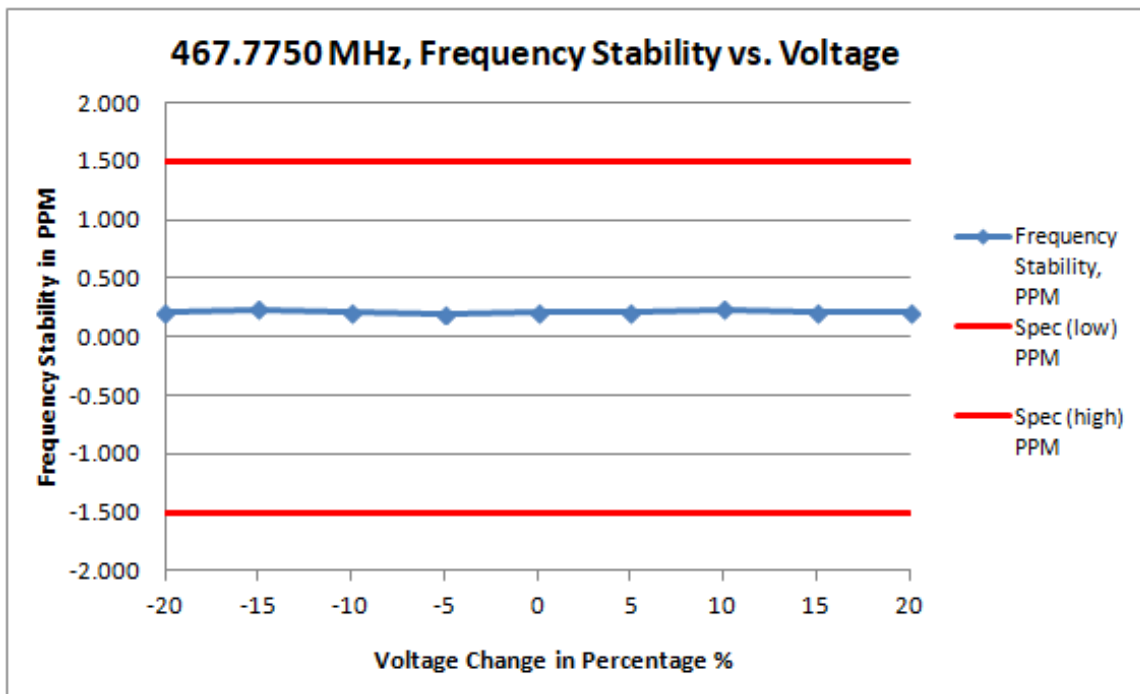

Frequency / Channel Spacing	467.775MHz / 12.5kHz				
Temperature, °C	25				
Voltage %	Voltage, V	Frequency, MHz	Frequency Stability, PPM	Spec (low) PPM	Spec (high) PPM
-20	6.000	467.775100	0.214	-1.500	1.500
-15	6.120	467.775110	0.235	-1.500	1.500
-10	6.480	467.775100	0.214	-1.500	1.500
-5	6.840	467.775090	0.192	-1.500	1.500
0	7.200	467.775100	0.214	-1.500	1.500
5	7.560	467.775100	0.214	-1.500	1.500
10	7.920	467.775110	0.235	-1.500	1.500
15	8.280	467.775100	0.214	-1.500	1.500
20	8.640	467.775100	0.214	-1.500	1.500

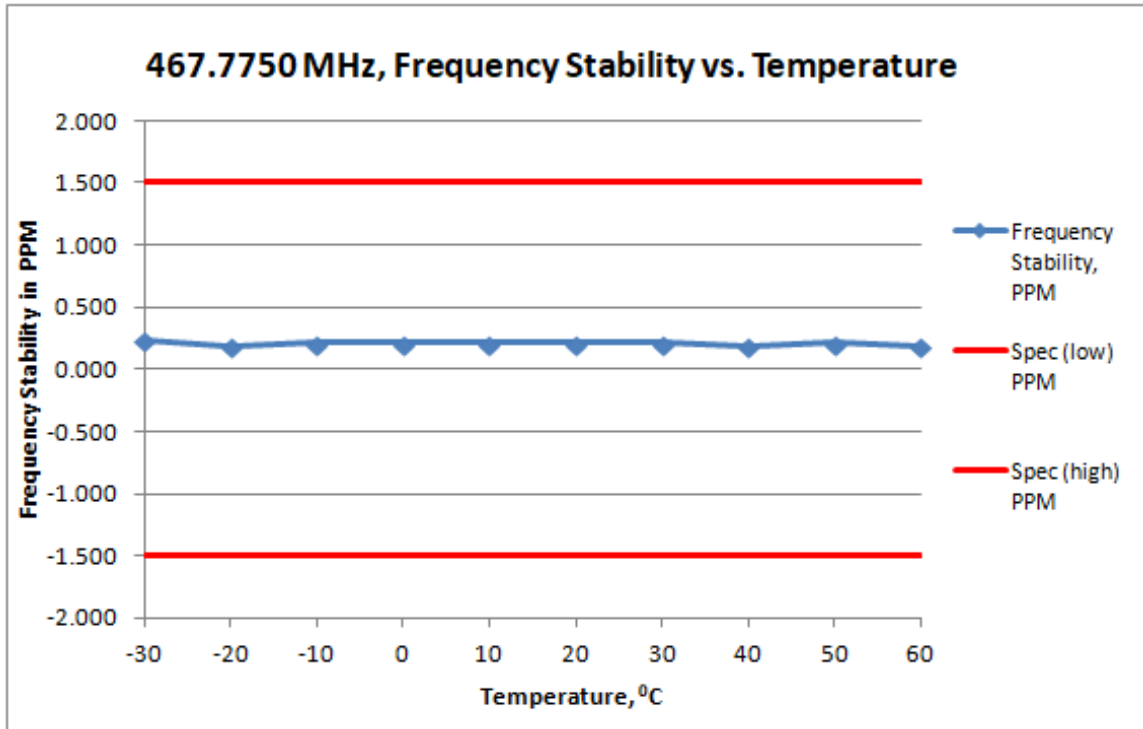

Frequency / Channel Spacing	467.775MHz / 12.5kHz			
Voltage, V	7.2			
Temperature, °C	Frequency, MHz	Frequency Stability, PPM	Spec (low) PPM	Spec (high) PPM
-30	467.775110	0.235	-1.500	1.500
-20	467.775090	0.192	-1.500	1.500
-10	467.775100	0.214	-1.500	1.500
0	467.775100	0.214	-1.500	1.500
10	467.775100	0.214	-1.500	1.500
20	467.775100	0.214	-1.500	1.500
30	467.775100	0.214	-1.500	1.500
40	467.775090	0.192	-1.500	1.500
50	467.775100	0.214	-1.500	1.500
60	467.775090	0.192	-1.500	1.500

6.2.3. Test Limit

As per manufacturer declared spec +/- 1.5ppm

6.3. Audio Frequency Response

6.3.1. Test Setup

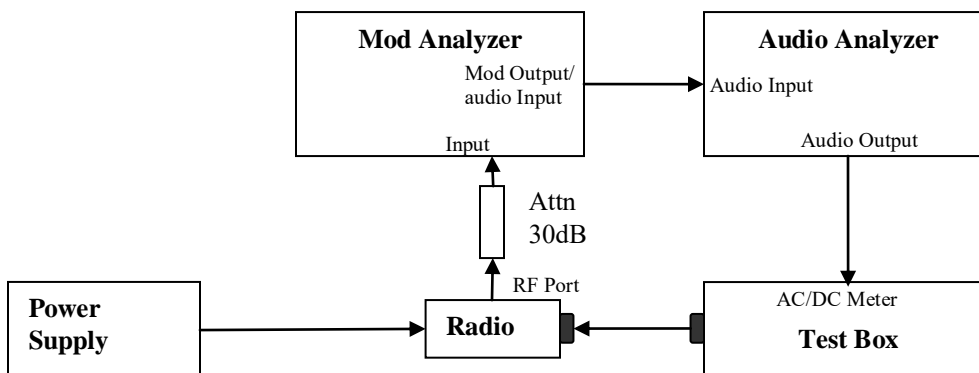

- 1) The DUT transmitter output port was connected to Modulation Analyzer.
- 2) Path loss for the measurement included.
- 3) Set the audio bandwidth filter to 15 kHz and 50 kHz.
- 4) Transmit the radio and set the audio analyzer to 1 kHz audio frequency and 20% of the Full rated system deviation.
- 5) On audio analyzer, set the rated level as reference to zero.
- 6) Vary the audio frequency from 300 Hz to 3 kHz. Record the change in dB on the audio analyzer.

6.3.2. Test Result

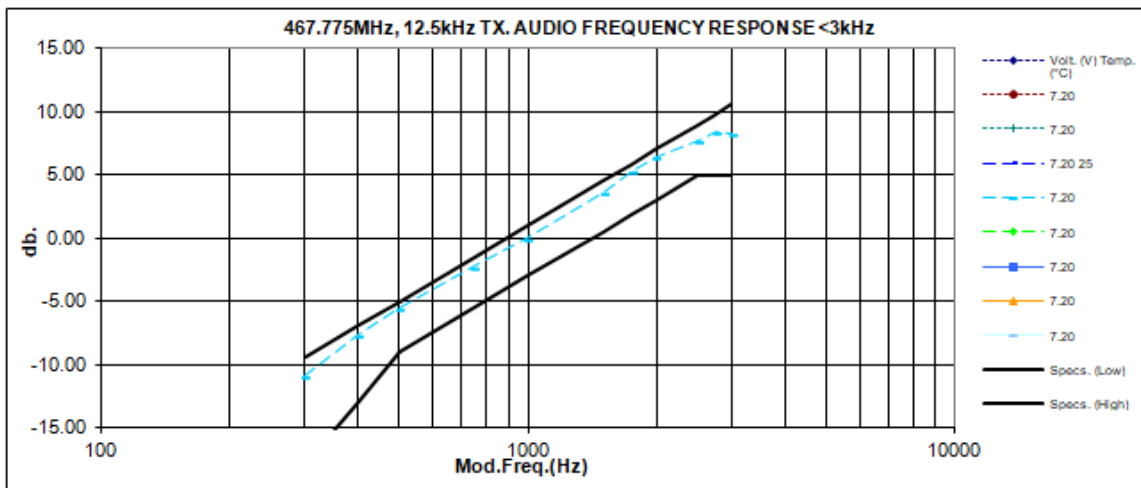
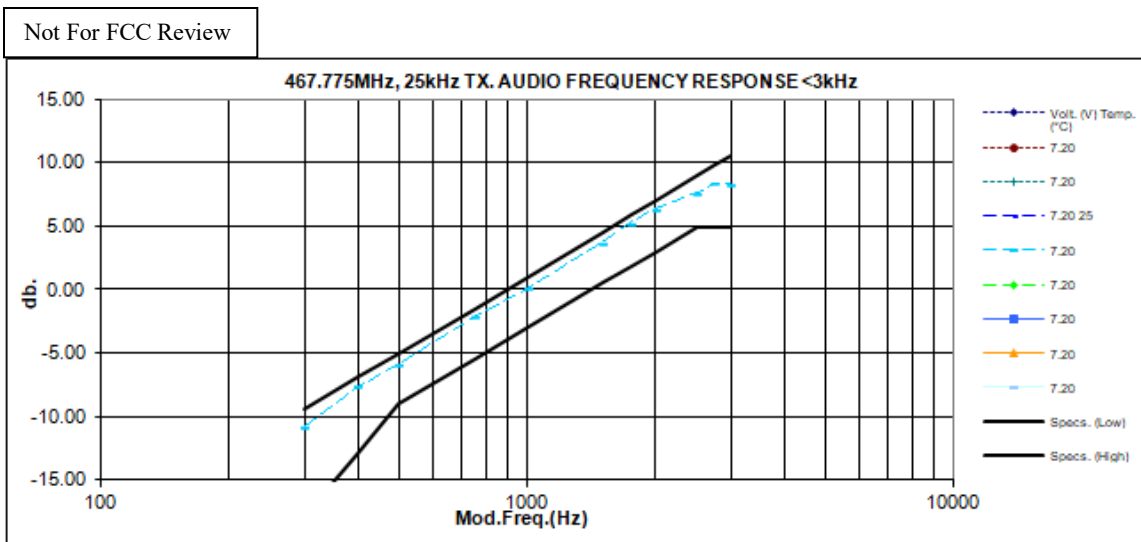

Not For FCC Review

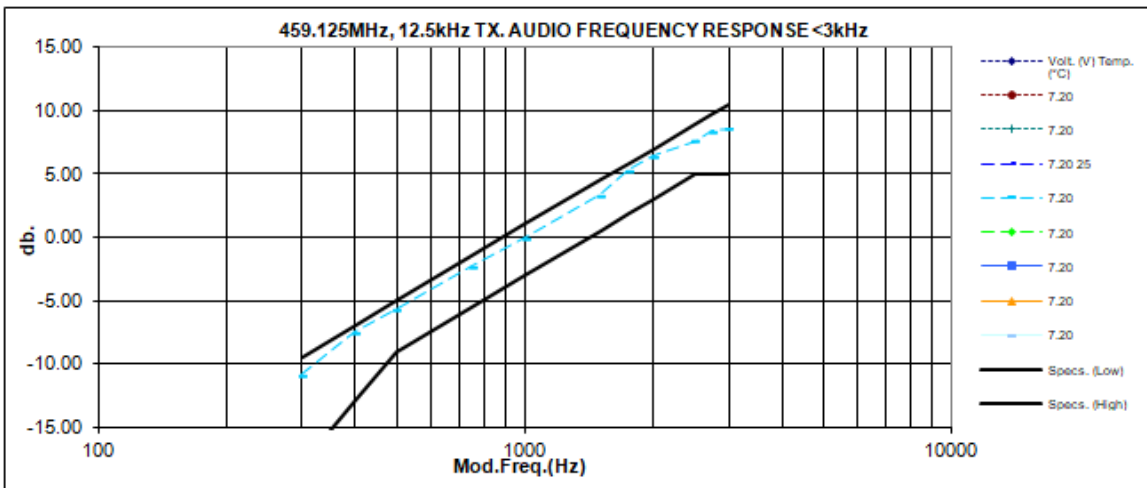
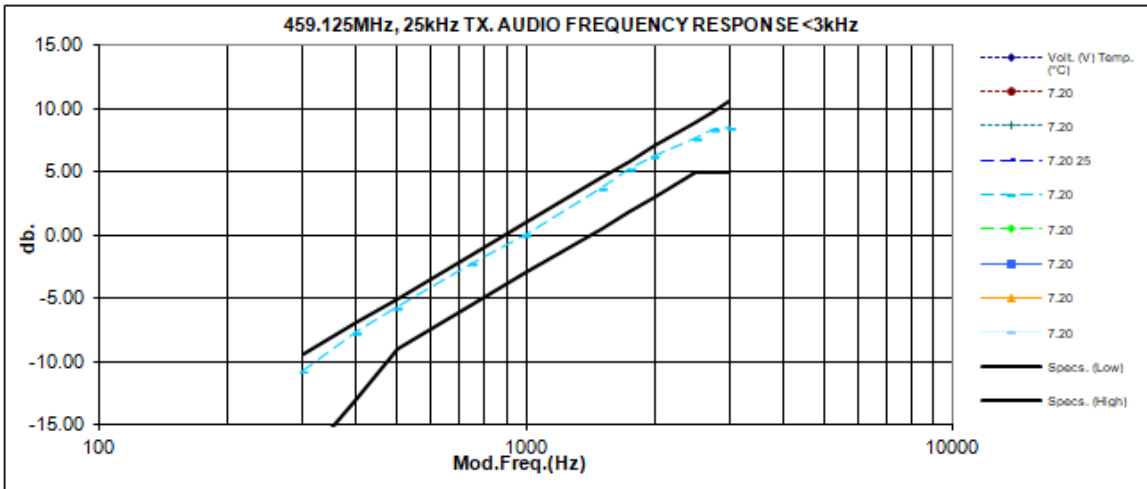

6.3.3. Test Limit

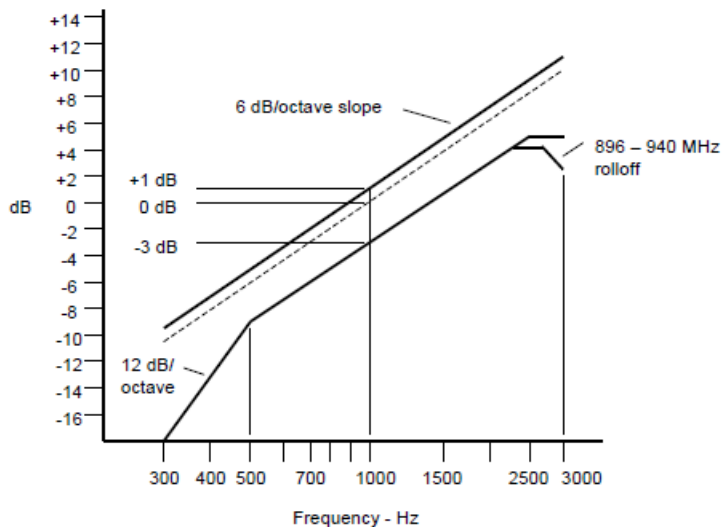

Note:

- o There are additional 6 dB per octave attenuation is allowed from 2.5KHz to 3KHz in equipment 25MHz to 869MHz radio.
- o Additional 6 dB per octave attenuation is allowed from 2.3KHz to 2.7KHz & additional 12 dB per octave attenuation is allowed from 2.7KHz to 3KHz in equipment 896MHz to 940MHz radio.

6.4. Audio Low Pass Filter Response

6.4.1. Test Setup

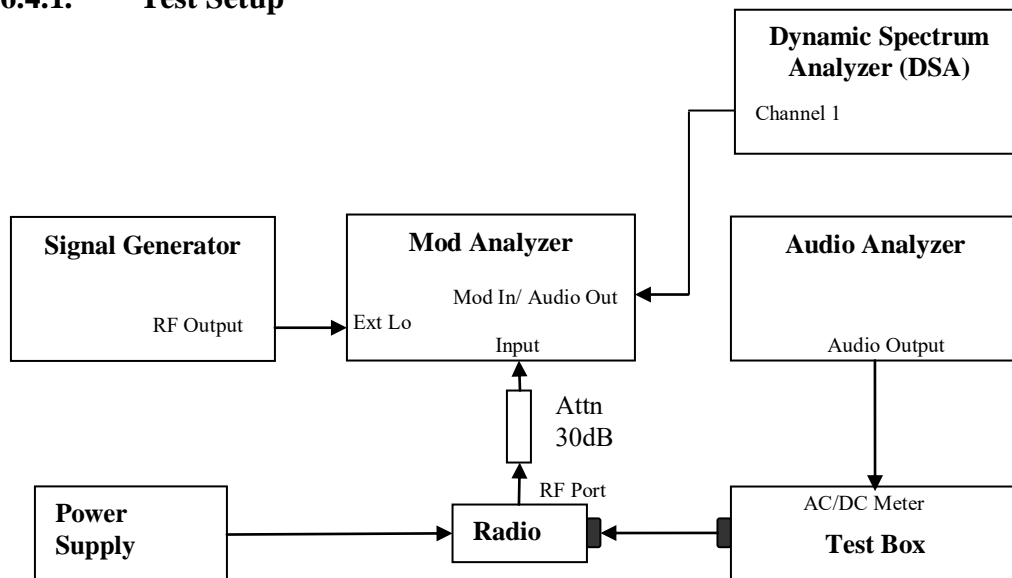

- 1) The DUT transmitter output port was connected to Modulation Analyzer.
- 2) Path loss for the measurement included.
- 3) Press 23.1SPCL on modulation analyzer to enable the external LO from Sigen.
- 4) Set the Sigen frequency to $F_c + 1.5$ MHz, RF output level to 0dBm without modulation.
- 5) Transmit the radio and set the audio analyzer to 1 kHz audio frequency and 60% of the Full rated system deviation.
- 6) Up the amplitude by 20dB.
- 7) On DSA, get the reference point to 0dB.
- 8) Vary the frequency on audio analyzer from 3 kHz to 20 kHz, record the audio tone from DSA.

6.4.2. Test Result NA → Not Applicable

6.4.3. Test Limit

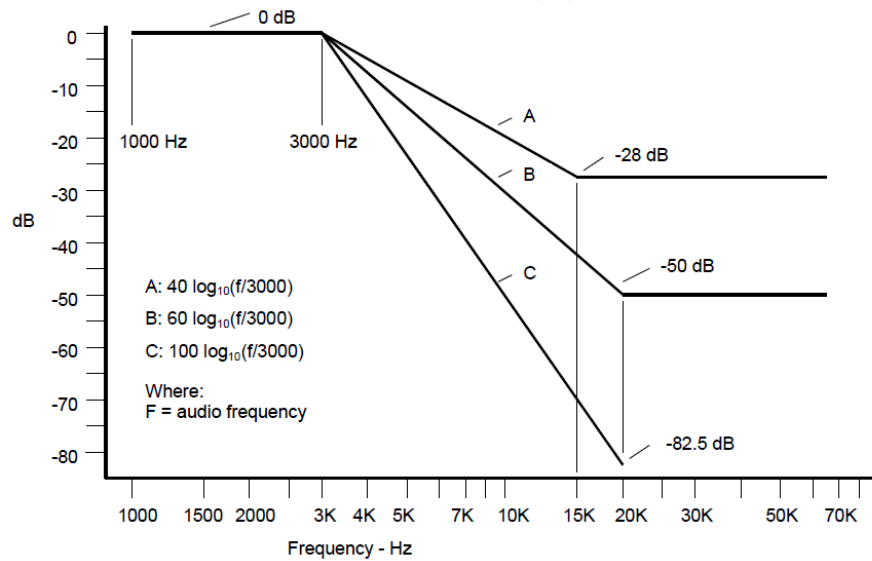

For audio frequencies above 3000 Hz, the audio response of the post limiter low-pass filter shall meet or exceed the following requirements:

- a) For equipment operating on 20, 25 or 30 kHz channel bandwidth in the 25 MHz to 174 MHz range:

At frequencies from 3000 Hz through 15,000 Hz the attenuation shall be greater than the attenuation at 1000 Hz by at least: $40 \log_{10}(f/3000)$ dB

where: f is the audio frequency in Hz.

At frequencies above 15,000 Hz, the attenuation shall be greater than the attenuation at 1000 Hz, by at least: 28 dB.

- b) For equipment operating with 25 kHz bandwidth channels between 406 and 512 MHz through 896 MHz, and between 929 MHz through 930 MHz:

At frequencies from 3000 Hz through 20,000 Hz, the attenuation shall be greater than the attenuation at 1000 Hz by at least: $60 \log_{10}(f/3000)$ dB

where: f is the audio frequency in Hz.

At frequencies above 20,000 Hz the attenuation shall be greater than the attenuation at 1000 Hz by at least: 50 dB.

- c) For equipment operating on channels between 896 MHz through 901 MHz, between 935 MHz through 940 MHz, and 12.5 or 15 kHz spaced channels in the frequency range 138-174 MHz and 406-512 MHz.

At frequencies from 3000 Hz through 20,000 Hz the attenuation shall be greater than the attenuation at 1000 Hz by at least: $100 \log_{10}(f/3000)$ dB

where: f is the audio frequency in Hz.

6.5. Modulation Limiting

6.5.1. Test Setup

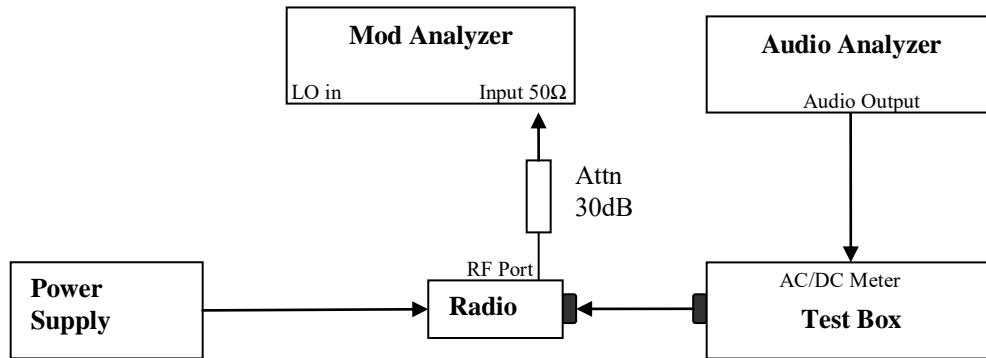

- 1) The DUT transmitter output port was connected to Modulation Analyzer.
- 2) Path loss for the measurement included.
- 3) Set the audio bandwidth filter to 15 kHz.
- 4) Transmit the radio and set the audio analyzer to 1 kHz audio frequency and 60% of the Full rated system deviation.
- 5) Record the frequency deviation as 0dB input level at 1kHz audio frequency.
- 6) Repeat the step and record the frequency deviation from -20 dB to 20dB by 5 dB increments and different audio freq 300 Hz, 2.5 kHz and 3 kHz.

6.5.2. Test Result

Not For FCC Review

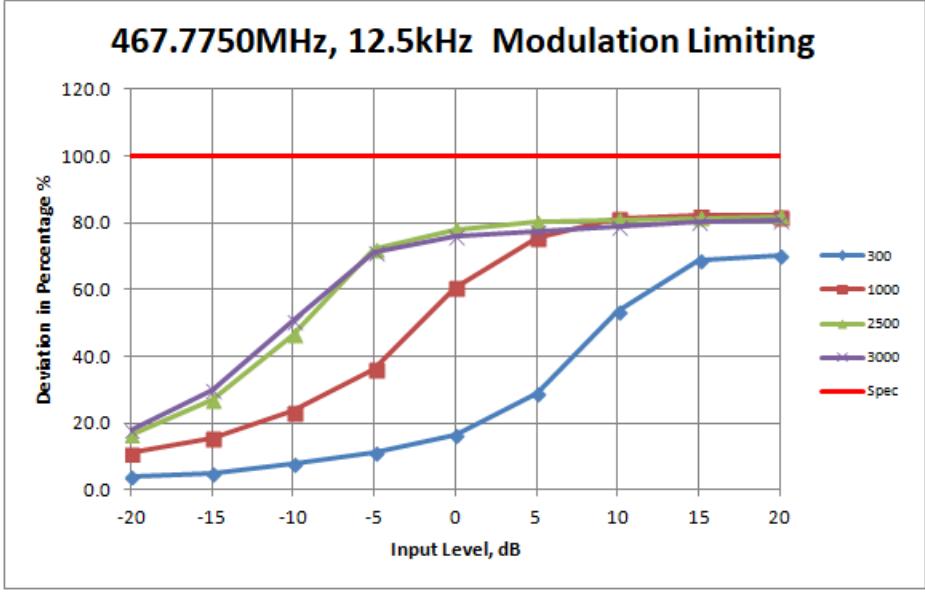
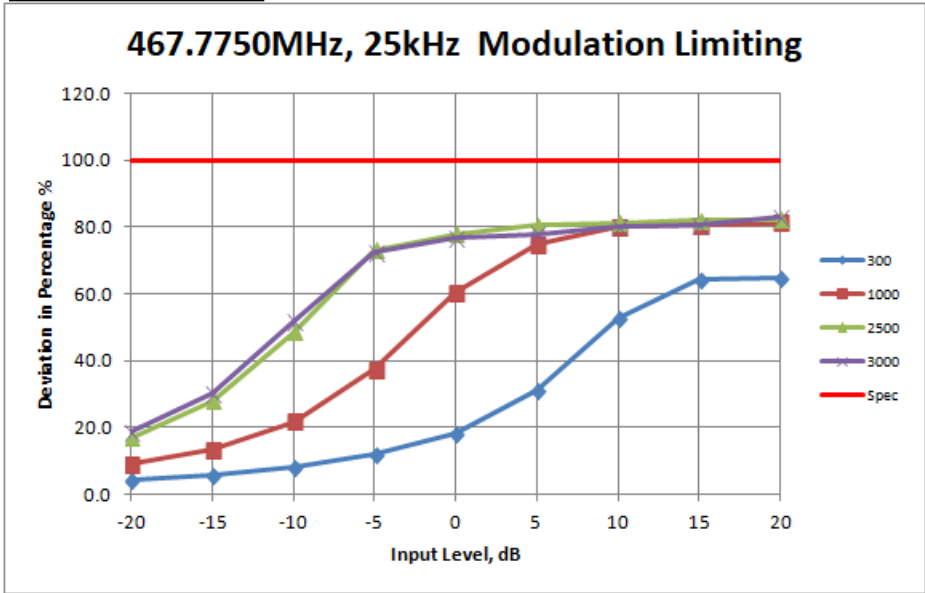

Not For FCC Review

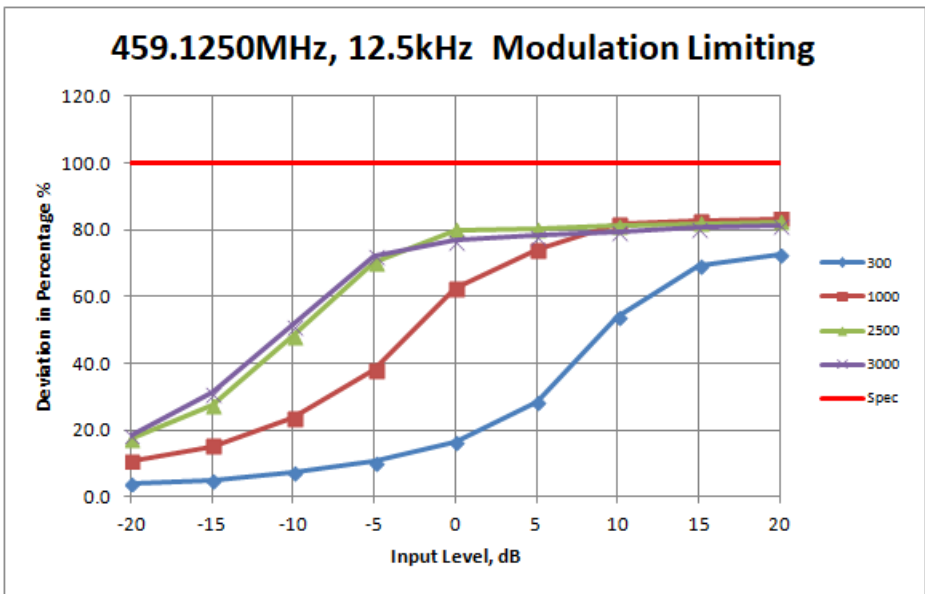
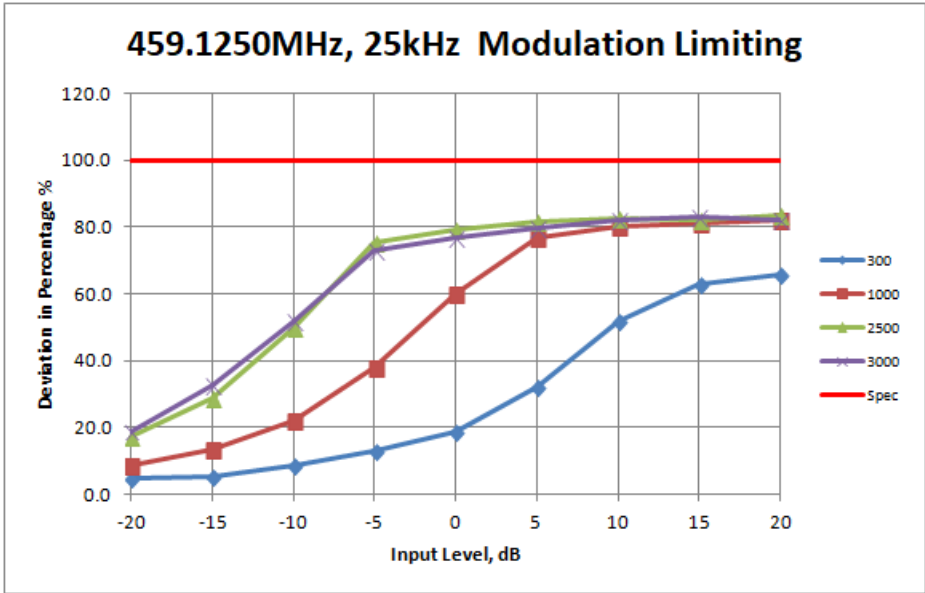

6.5.3. Test Limit
Modulation Limiting shall not exceed 100 percent.

6.6. Occupied Bandwidth

6.6.1. Test Setup (Analog)

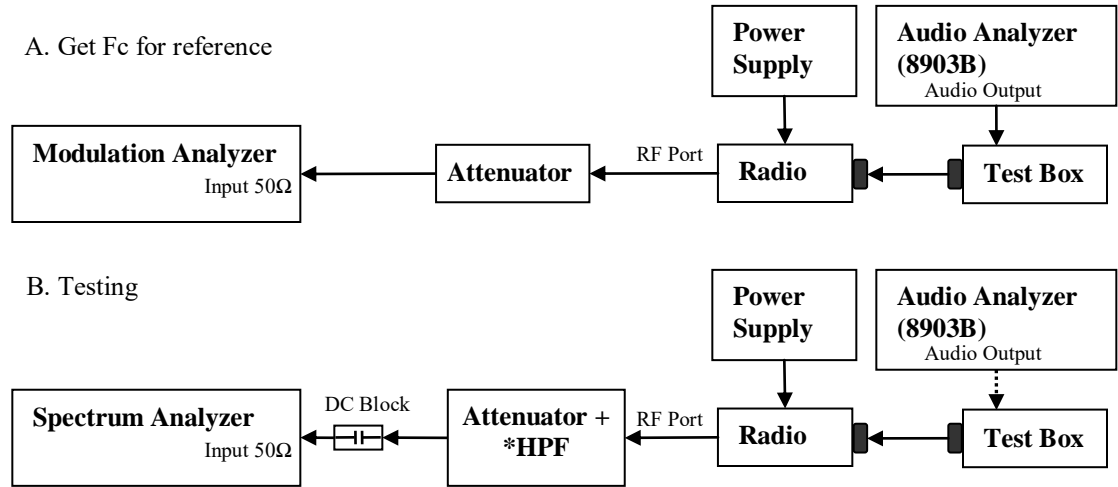

- 1) The DUT transmitter output port was connected to Modulation Analyzer.
- 2) Set the audio bandwidth filter to 15 kHz low pass filter and 50 kHz high pass filter.
- 3) Transmit the radio and set the audio analyzer to 2.5 kHz audio frequency and 50% of the rated deviation. Up the amplitude by 16 dB. Dekey the DUT.
- 4) Path loss for the measurement included.
- 5) Select the Occupied Bandwidth measurement for 99% Emissions Bandwidth Measurement.
- 6) Key in the Fc and Resolution Bandwidth (1 ~ 5 % of emission designator).
- 7) Transmit the DUT and record the occupied Bandwidth frequency.
- 8) Preset the spectrum analyzer for sideband spectrum measurement.
- 9) Set the span and Resolution Bandwidth (according to FCC/ ISED standard).
- 10) Save the screen shot as modulated signal
- 11) Remove the audio tone from audio analyzer to capture unmodulated signal.

* Only HPF added for Mask 80.211 measurement with attenuator.

6.6.2. Test Result (Analog)

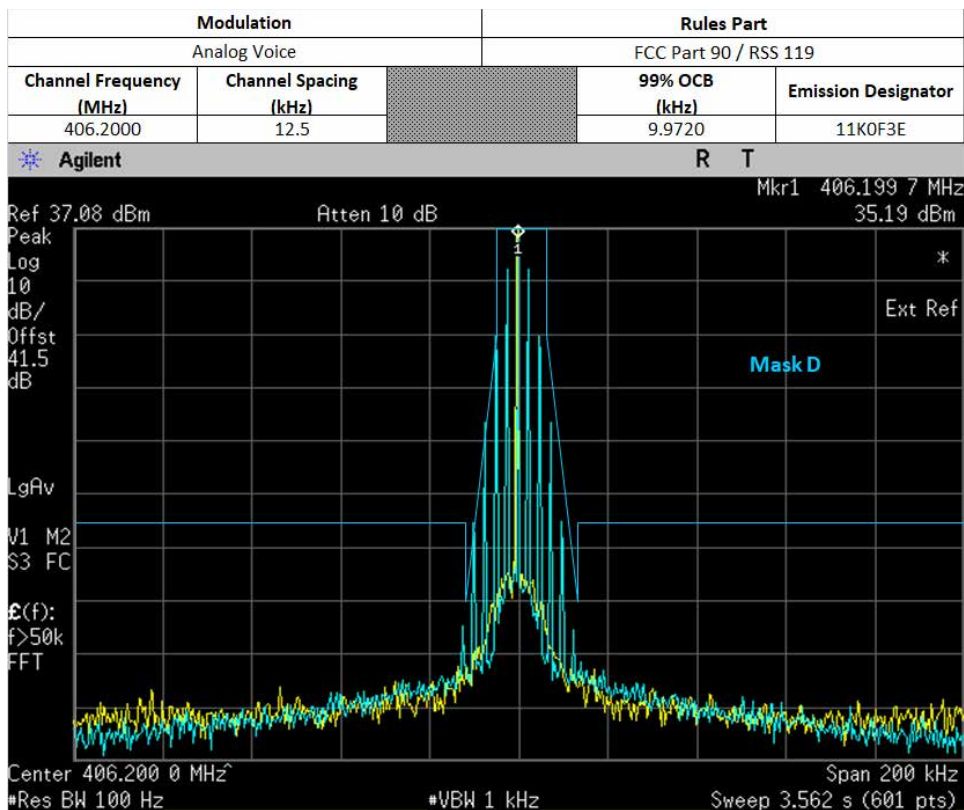
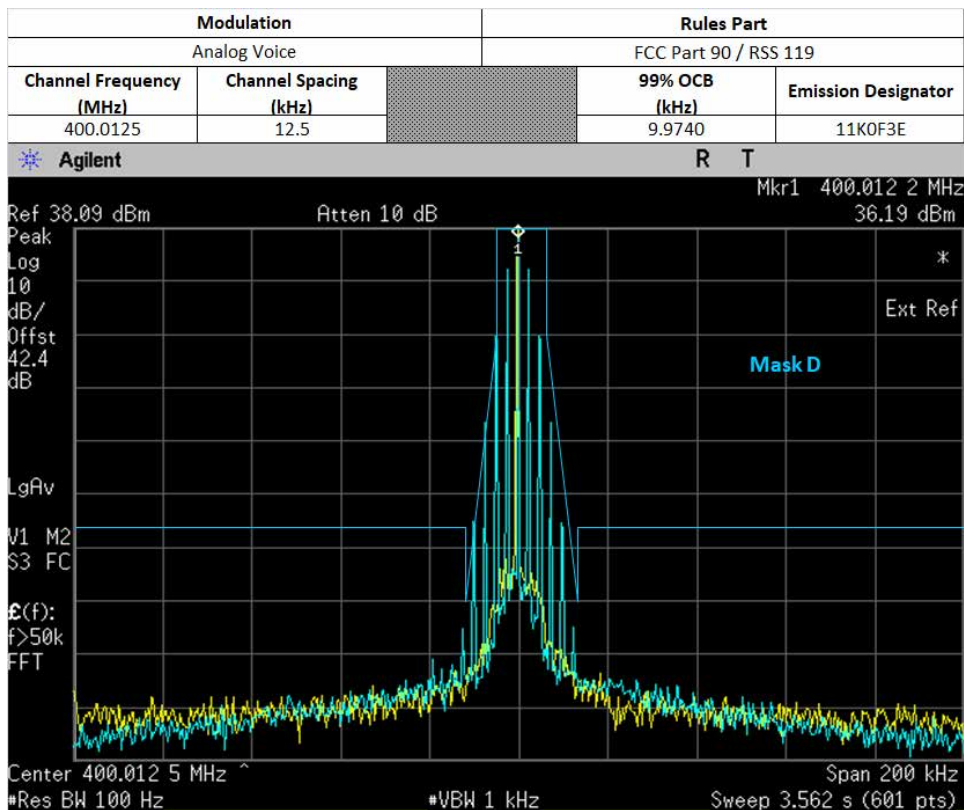

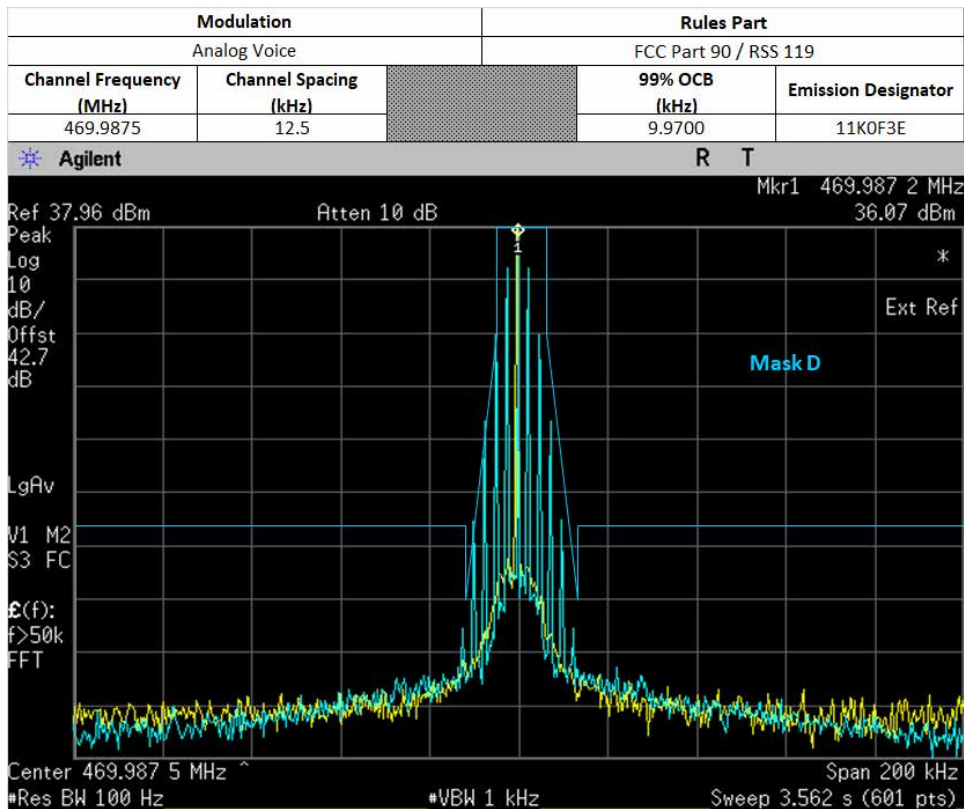
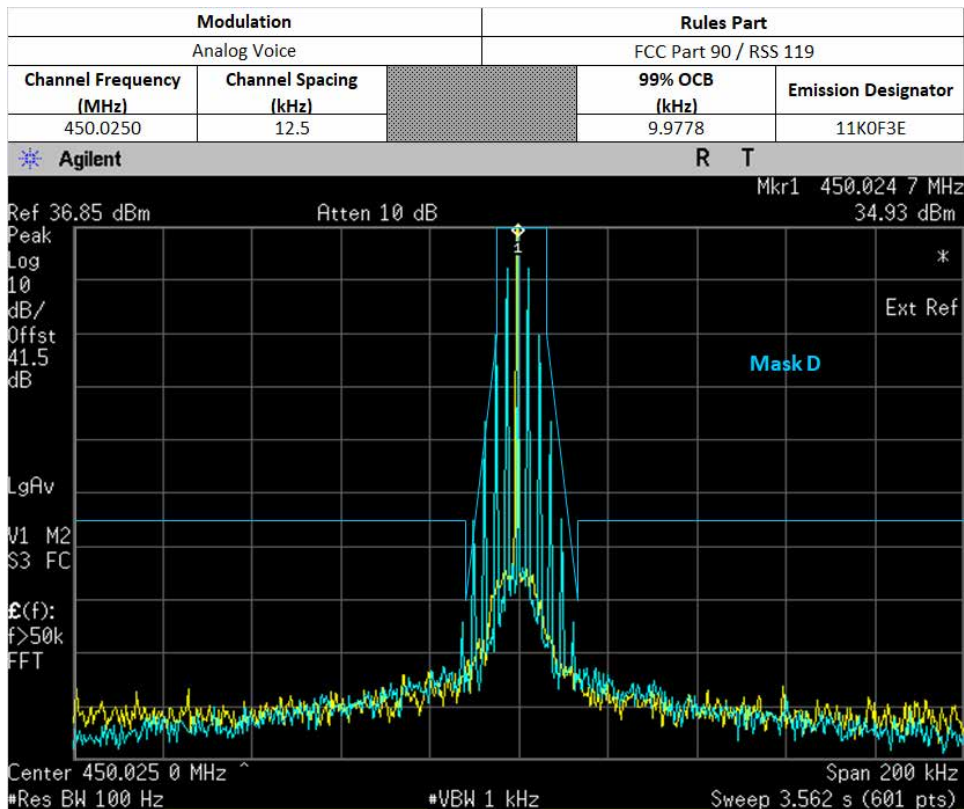

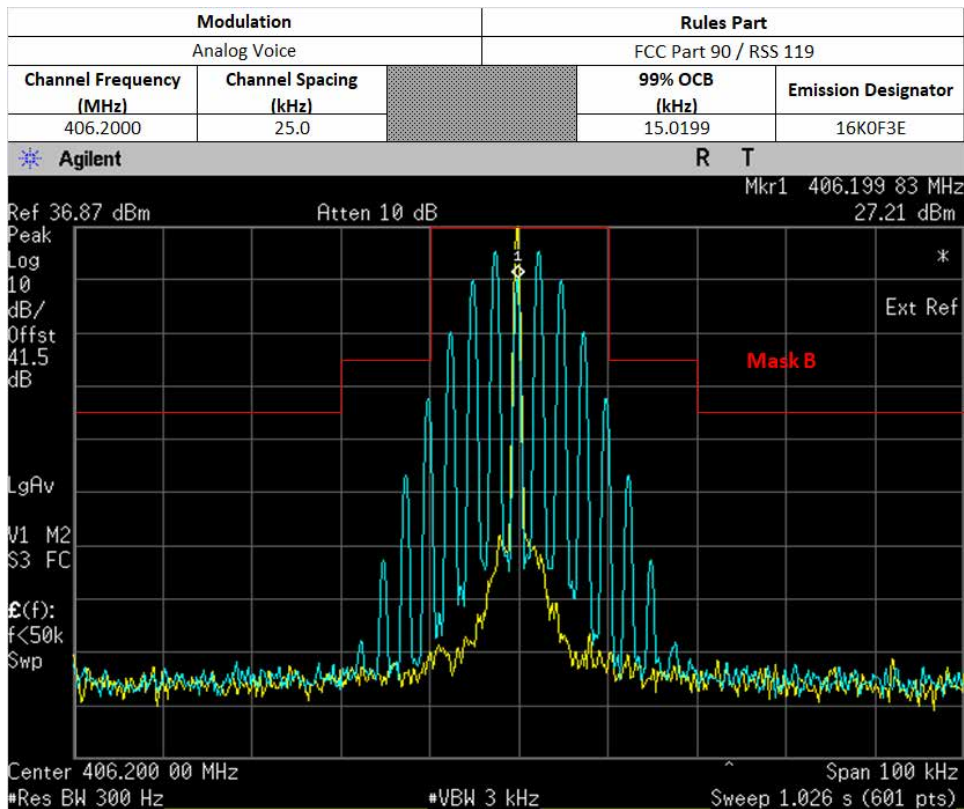
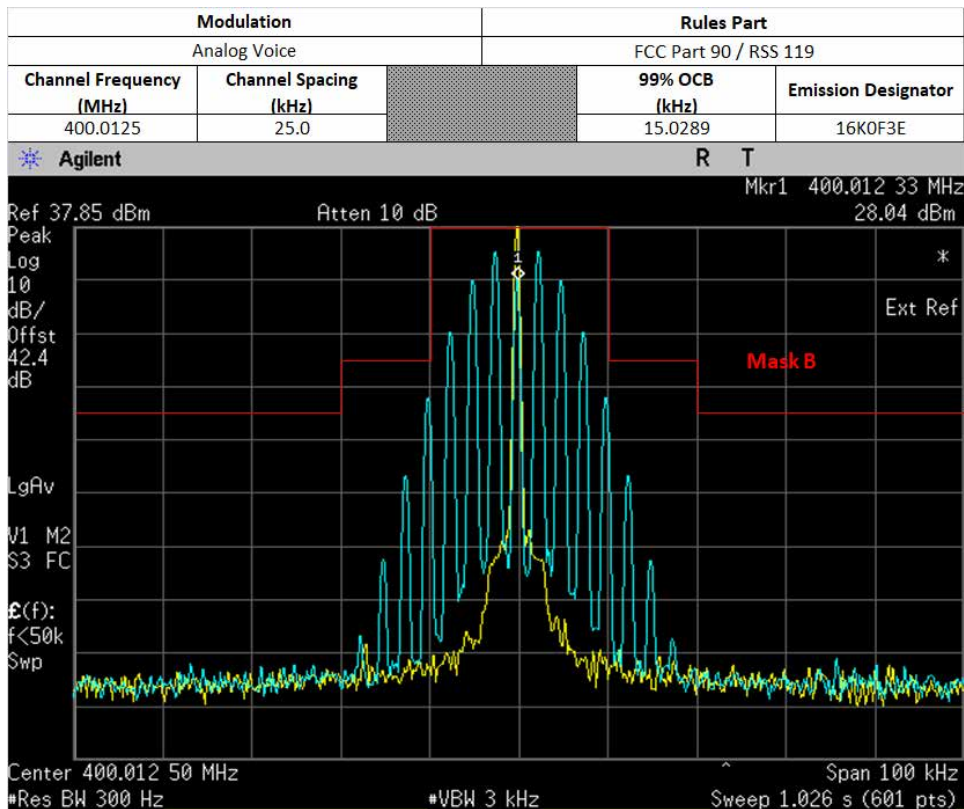

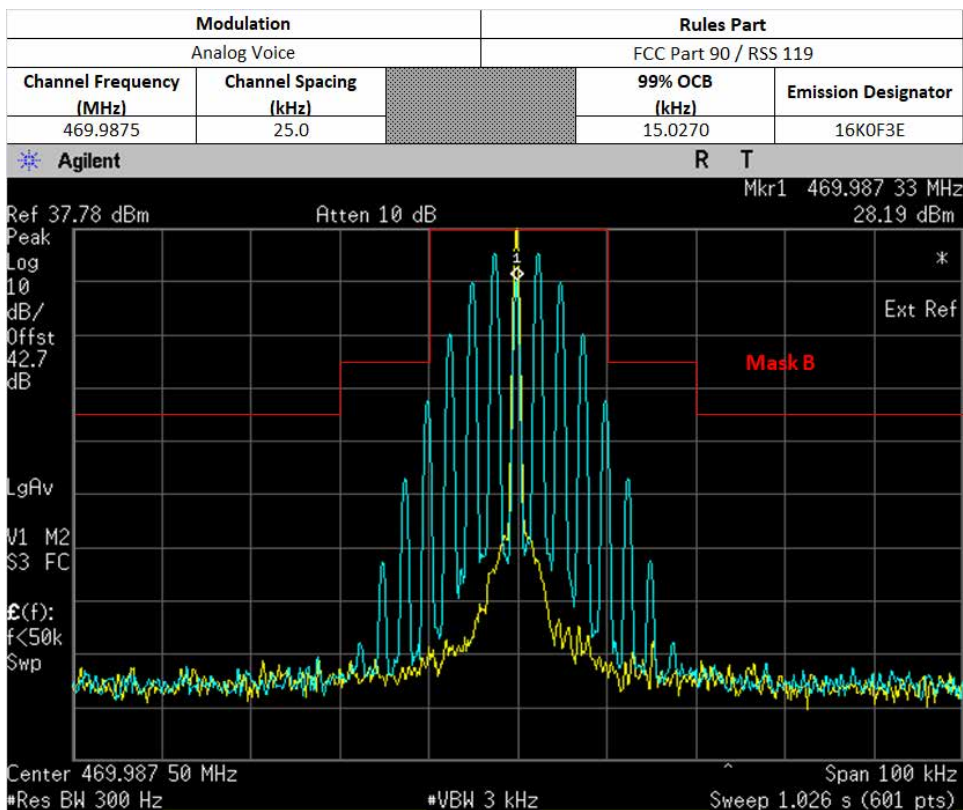
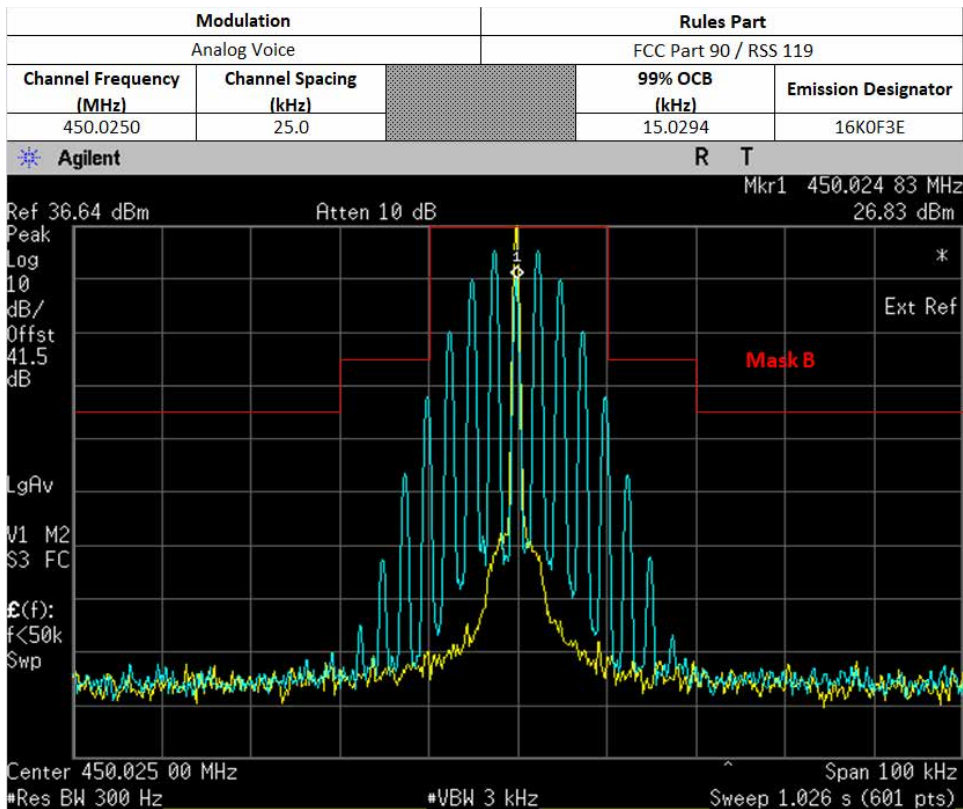

6.6.3. Test Setup (Digital)

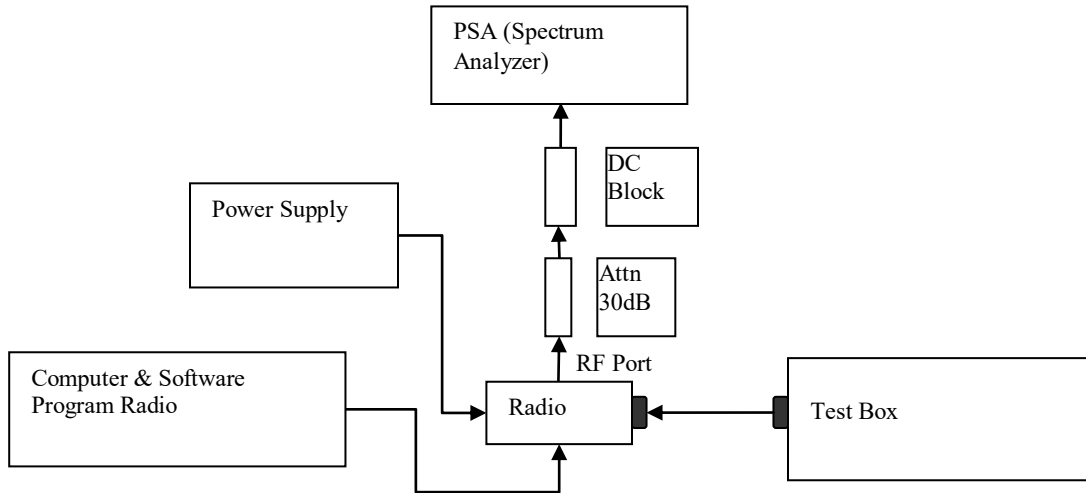

- 1) Program and set radio to operate in desire test frequency and digital mode with modulation. (*4FSK, C4FM or other digital modulation form).
- 2) Path loss for the measurement included.
- 3) Select the Occupied Bandwidth measurement for 99% Emissions Bandwidth Measurement.
- 4) Key in the Fc and Resolution Bandwidth (1 ~ 5 % of emission designator).
- 5) Transmit the DUT and record the occupied Bandwidth frequency.
- 6) Preset the spectrum analyzer for modulation emission spectrum measurement.
- 7) Set the span and Resolution Bandwidth (according to FCC/ ISED standard).
- 8) Capture the screen shot as modulated signal.

*Note:

- For Digital Modulation, 12.5 kHz Data F1D & FXD would be the same. Therefore only measurements with F1D modulation shown below.
- For Digital Modulation, 12.5 kHz Data F1E & FXE would be the same. Therefore only measurements with F1E modulation shown below.

6.6.4. Test Result (Digital) NA → Not Applicable

6.6.5. Test Limit

The 99% occupied bandwidth is the width of a frequency band such that, below the lower and above the upper frequency limits, the mean powers emitted are each equal to a specified percentage 0.5% of the total mean transmitted power.

6.7. Band Edge Conducted Spurious Emission (Part 22)

6.7.1. Test Setup (Analog)

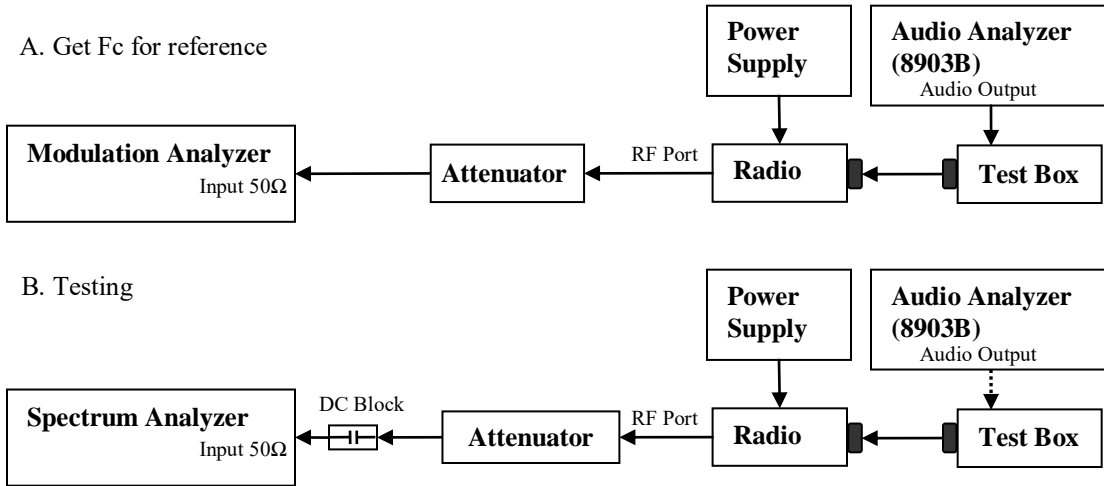

- 1) The DUT transmitter output port was connected to Modulation Analyzer.
- 2) Set the audio bandwidth filter to 15 kHz low pass filter and 50 kHz high pass filter.
- 3) Transmit the radio and set the audio analyzer to 2.5 kHz audio frequency and 50% of the rated deviation. Up the amplitude by 16 dB. Dekey the DUT.
- 4) Path loss for the measurement included.
- 5) Select the Occupied Bandwidth measurement for 99% and 26dB Emissions Bandwidth Measurement.
- 6) Key in the Fc and Resolution Bandwidth.
- 7) Transmit the DUT and record the occupied Bandwidth frequencies.
- 8) Preset the spectrum analyzer for band edge measurement.
- 9) The band edges of lowest and highest channels were measured.
- 10) Key in the Lowest and highest channel frequency, span is 60 kHz and Resolution Bandwidth is at least 1% of Emission Bandwidth.
- 11) Save the screen shot as modulated signal.
- 12) Remove the audio tone from audio analyzer to capture unmodulated signal.

*Note:

- For emission designator ending with F3E, 16K0F3E is the worst case and therefore only 16K0F3E will be shown.

6.7.2. Test Result (Analog) NA → Not Applicable

6.7.3. Test Setup (Digital)

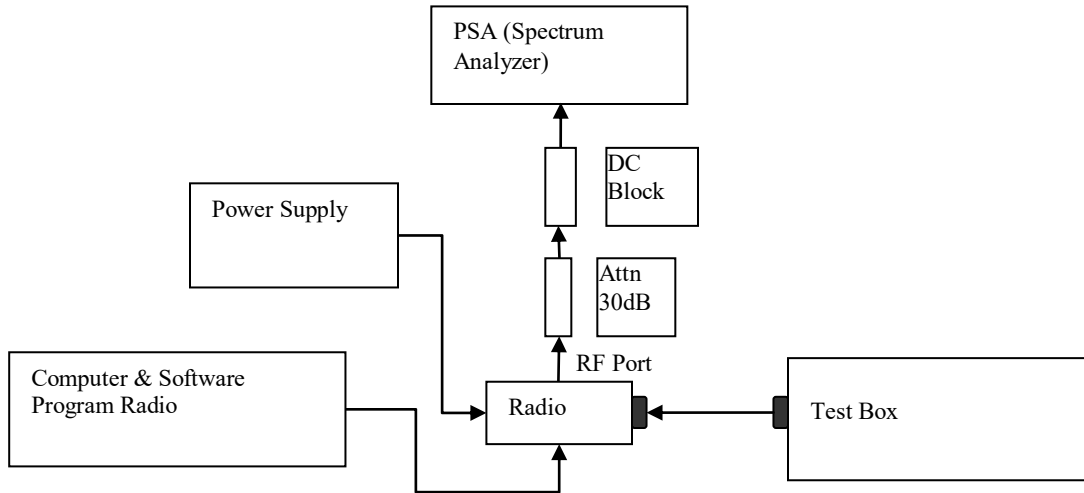

- 1) Program and set radio to operate in desire test frequency and digital mode with modulation. (*4FSK, C4FM or other digital modulation form).
- 2) Path loss for the measurement included.
- 3) Select the Occupied Bandwidth measurement for 99% and 26dB Emissions Bandwidth Measurement.
- 4) Key in the Fc and Resolution Bandwidth.
- 5) Transmit radio record the occupied Bandwidth frequencies.
- 6) Preset the spectrum analyzer for band edge measurement.
- 7) Key in the lowest and highest channels frequency, span is 60 kHz and Resolution Bandwidth is at least 1% of Emission Bandwidth.
- 8) Save the screen shot.

*Note:

- All digital modulation modes utilize the same high deviation test pattern, and they are therefore identical. Hence, only FID plots will be shown.

6.7.4. Test Result (Digital) NA → Not Applicable

6.7.5. Test Limit

The power of any emission outside of the authorized operating frequency ranges must be attenuated below the transmitting power (P) by a factor of at least $43 + 10 \log(P)$ dB.

6.8. Transient Frequency Behavior

6.8.1. Test Setup

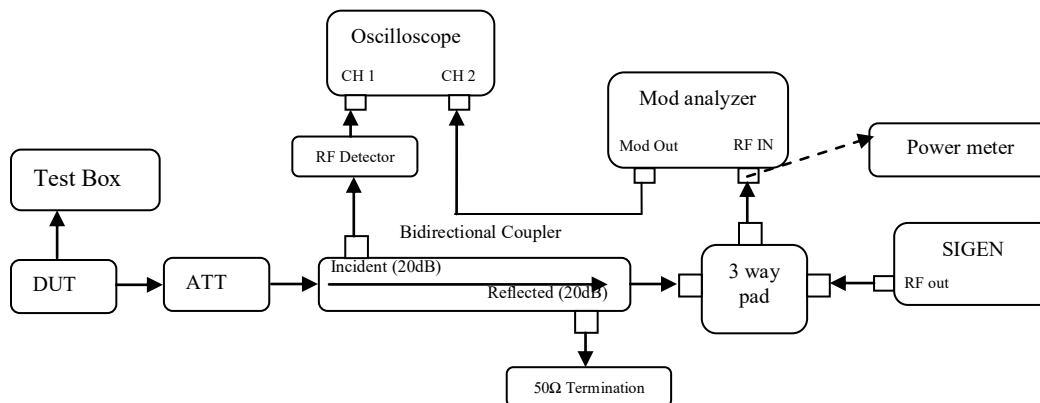

- 1) Connect the setup as figure above.
- 2) Path loss for the measurement included.
- 3) Set on Sigen with the assigned center frequency, internal 1 kHz FM tone.
FM Deviation: Analog 25kHz Channel Spacing = 25 kHz
Analog 12.5 kHz Channel Spacing = 12.5 kHz
C4FM = 12.5 kHz
- 4) Turn on 50 kHz high pass filter and 15 kHz low pass filter on modulation analyzer.
- 5) Supply sufficient attenuation ATT to provide the output power of $\leq -11\text{dBm}$ into power meter when DUT is keying up.
- 6) Note the power level on power meter and dekey the DUT.
- 7) Adjust the amplitude of the signal generator to the level power meter, maintained the amplitude throughout the rest of the measurement.
- 8) Connect the output to modulation analyzer.
- 9) Reduce 30dB attenuation and transmit the radio to get the trigger line.
- 10) Capture the screen shot for key-up (rising edge) and de-key (falling edge) mode.

6.8.2. Test Result

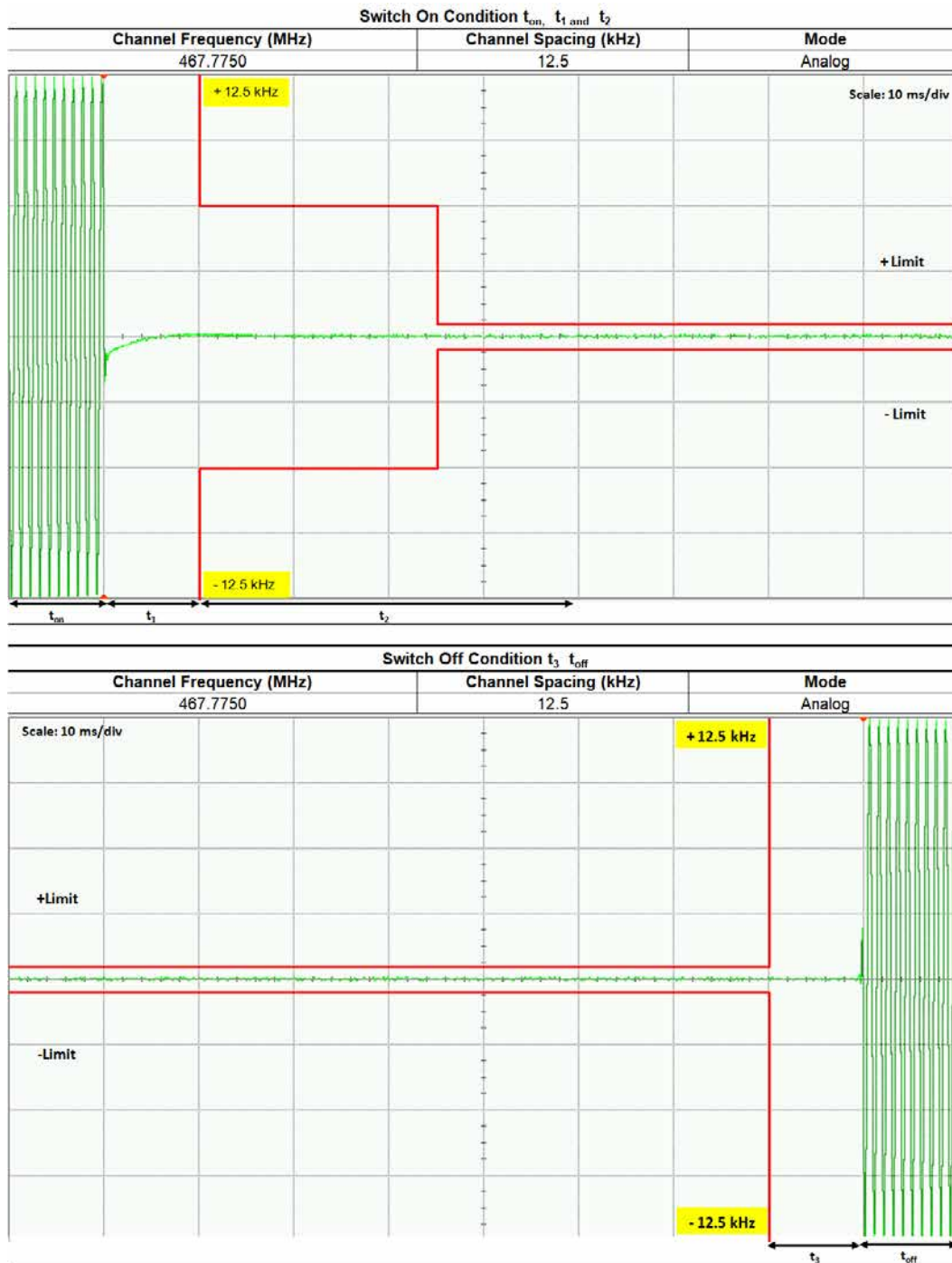

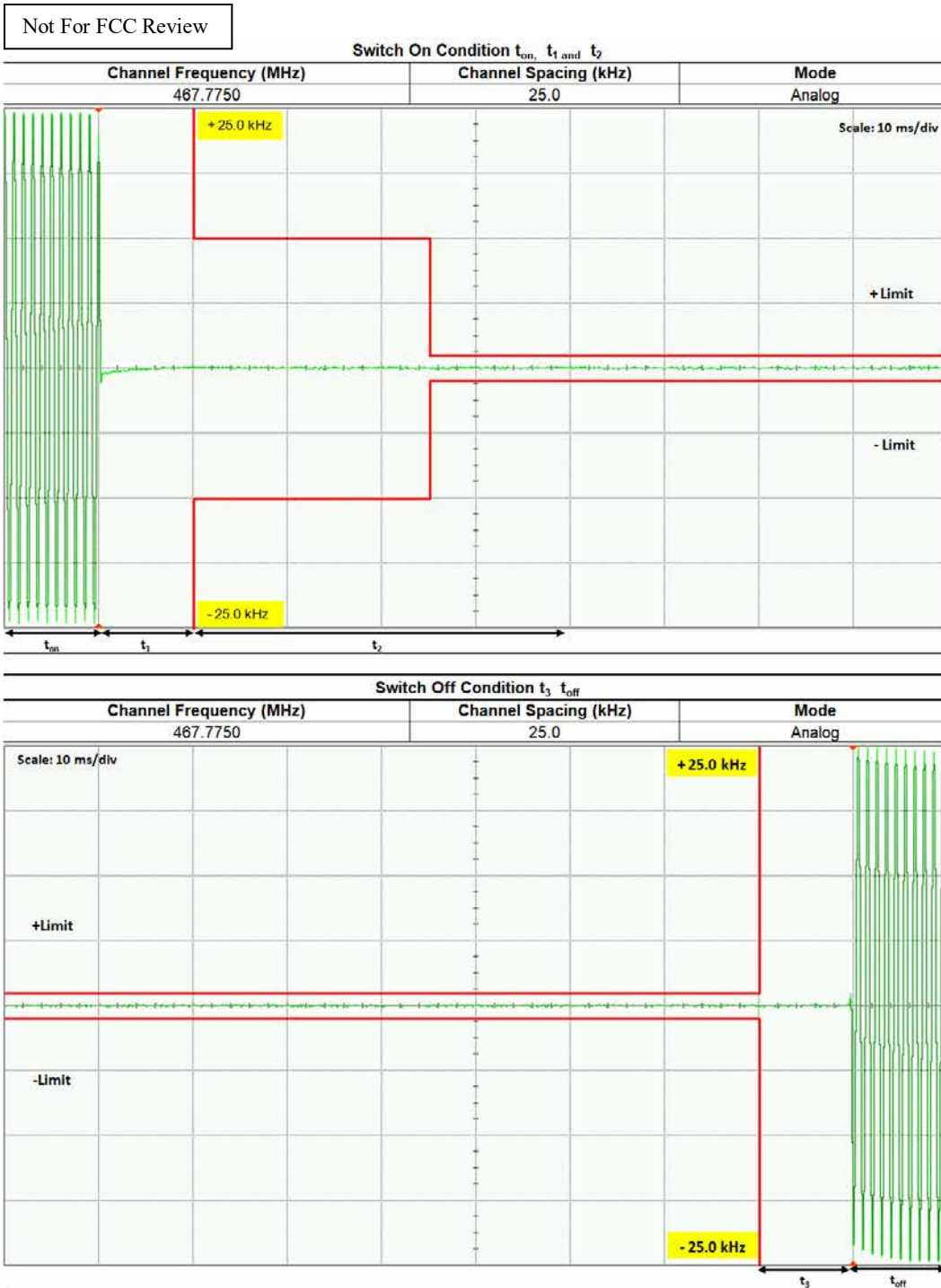

6.8.3. Test Limit

Transmitters designed to operate in the 150-174 MHz and 421-512 MHz frequency bands must maintain transient frequencies within the maximum frequency difference limits during the time intervals indicated:

Time intervals ^{1 2}	Maximum frequency difference ³	All equipment	
		150 to 174 MHz	421 to 512 MHz
Transient Frequency Behavior for Equipment Designed to Operate on 25 kHz Channels			
t ₁ ⁴	±25.0 kHz	5.0 ms	10.0 ms
t ₂	±12.5 kHz	20.0 ms	25.0 ms
t ₃ ⁴	±25.0 kHz	5.0 ms	10.0 ms
Transient Frequency Behavior for Equipment Designed to Operate on 12.5 kHz Channels			
t ₁ ⁴	±12.5 kHz	5.0 ms	10.0 ms
t ₂	±6.25 kHz	20.0 ms	25.0 ms
t ₃ ⁴	±12.5 kHz	5.0 ms	10.0 ms
Transient Frequency Behavior for Equipment Designed to Operate on 6.25 kHz Channels			
t ₁ ⁴	±6.25 kHz	5.0 ms	10.0 ms
t ₂	±3.125 kHz	20.0 ms	25.0 ms
t ₃ ⁴	±6.25 kHz	5.0 ms	10.0 ms

¹ _{on} is the instant when a 1 kHz test signal is completely suppressed, including any capture time due to phasing.

t₁ is the time period immediately following t_{on}.

t₂ is the time period immediately following t₁.

t₃ is the time period from the instant when the transmitter is turned off until t_{off}.

t_{off} is the instant when the 1 kHz test signal starts to rise.

² During the time from the end of t₂ to the beginning of t₃, the frequency difference must not exceed the limits specified in §90.213.

³ Difference between the actual transmitter frequency and the assigned transmitter frequency.

⁴ If the transmitter carrier output power rating is 6 watts or less, the frequency difference during this time period may exceed the maximum frequency difference for this time period.

6.9. Adjacent Channel Power

6.9.1. Test Setup (Analog)

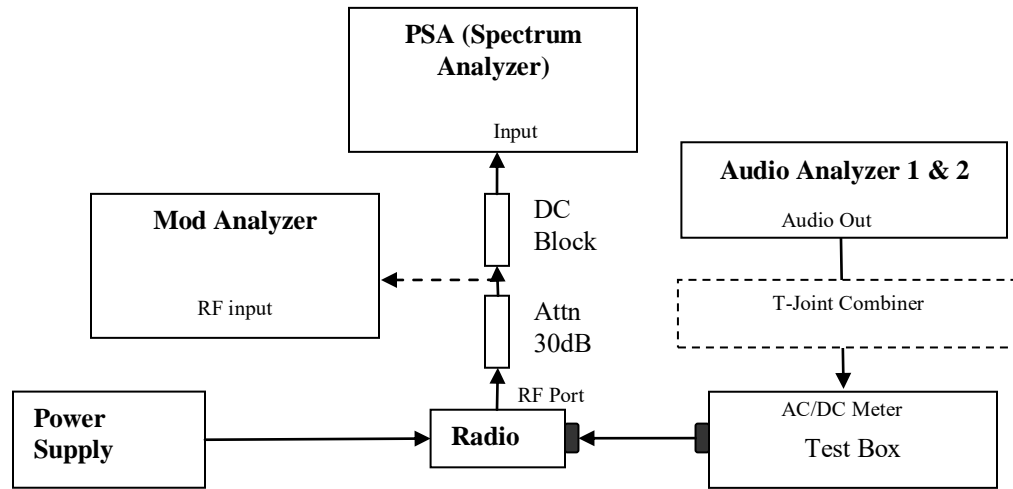

- 1) The DUT transmitter output port was connected to modulation analyzer.
- 2) Transmit the radio and turn on 1st audio analyzer with audio frequency 650Hz, 50% rated deviation, and record the amplitude value as AmpT1.
- 3) Turn off Audio analyzer 1 and turn on audio analyzer 2, set the audio frequency to 2.2 kHz and 50% deviation. Record the amplitude as AmpT2.
- 4) Turn both audio analyzers ON and up 10dB amplitude level.
- 5) Connect the output to PSA and set to assigned center frequency.
- 6) Set Span, Resolution Bandwidth and Video Bandwidth per rules part.
- 7) Transmit the radio and record the Adjacent Channel Power value in dBc.

6.9.2. Test Result(Analog) NA → Not Applicable

6.9.3. Test Setup (Digital)

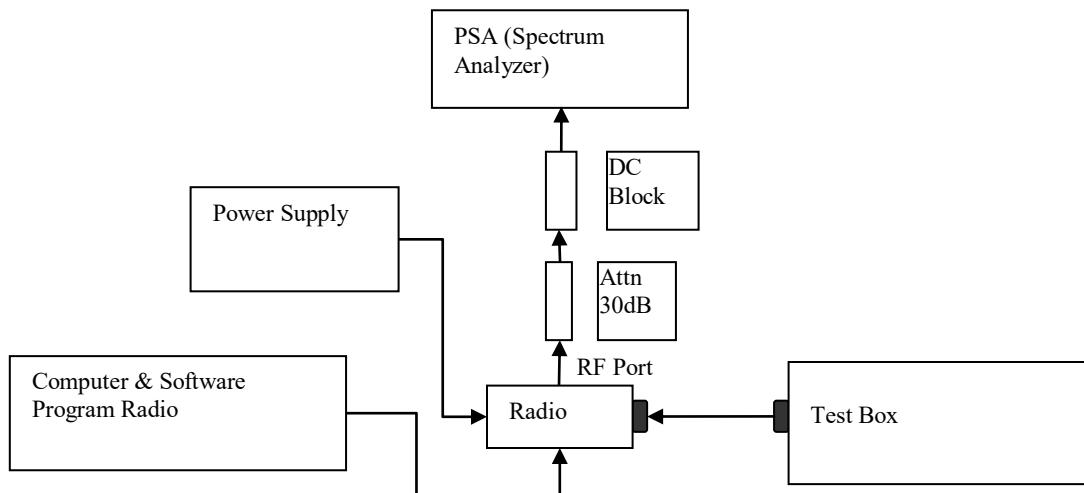

- 1) Program and set radio to operate in desire test frequency and digital mode with modulation. (4FSK, C4FM or other digital modulation form).
- 2) Prepare setup as per picture.
- 3) Turn on the ACP Measurement – Press Measure, ACP.
- 4) Set Span, Resolution Bandwidth and Video Bandwidth as per rules part.
- 5) Transmit the radio and record the Adjacent Channel Power value in dBc.

6.9.4. Test Result (Digital)

NA → Not Applicable

6.9.5. Test limit

12.5 kHz MOBILE TRANSMITTER ACP REQUIREMENTS

Offset from center frequency (kHz)	Measurement bandwidth (kHz)	Maximum ACP relative (dBc)
9.375	6.25	-40
15.625	6.25	-60
21.875	6.25	-60
37.50	25.00	-60
62.50	25.00	-65
87.50	25.00	-65
150.00	100	-65
250.00	100	-65
350.00	100	-65
>400 to 12 MHz	30 (s)	-75
12 MHz to paired receive band	30 (s)	-75
In the paired receive band	30 (s)	-100

25 kHz MOBILE TRANSMITTER ACP REQUIREMENTS

Offset from center frequency (kHz)	Measurement bandwidth (kHz)	Maximum ACP relative (dBc)
15.625	6.25	-40
21.875	6.25	-60
37.50	25	-60
62.50	25	-65
87.50	25	-65
150.00	100	-65
250.00	100	-65
350.00	100	-65
>400 kHz to 12 MHz	30 (s)	-75
12 MHz to paired receive band	30 (s)	-75
In the paired receive band	30 (s)	-100

12.5 kHz BASE TRANSMITTER ACP REQUIREMENTS

Offset from center frequency (kHz)	Measurement bandwidth (kHz)	Maximum ACP (dBc)
9.375	6.25	-40
15.625	6.25	-60
21.875	6.25	-60
37.5	25	-60
62.5	25	-65
87.5	25	-65
150	100	-65
250	100	-65
350.00	100	-65
>400 kHz to 12 MHz	30 (s)	-80
12 MHz to paired receive band	30 (s)	-80
In the paired receive band	30 (s)	1-85

25 kHz BASE TRANSMITTER ACP REQUIREMENTS

Offset from center frequency (kHz)	Measurement bandwidth (kHz)	Maximum ACP (dBc)
15.625	6.25	-40
21.875	6.25	-60
37.5	25	-60
62.5	25	-65
87.5	25	-65
150	100	-65
250	100	-65
350	100.00	-65
>400 kHz to 12 MHz	30 (s)	-80
12 MHz to paired receive band	30 (s)	-80
In the paired receive band	30 (s)	1-85

6.10. Conducted Spurious Emission

6.10.1. Test Setup

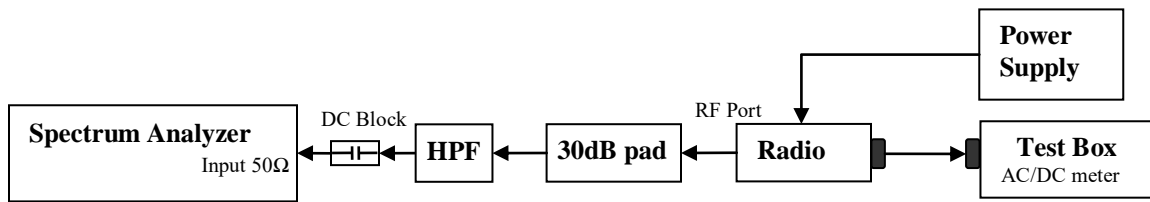

- 1) The DUT transmitter output port was connected to Spectrum Analyzer with above setup.
- 2) Program and set radio to operate in desire test frequency and mode. (Analog / digital modulation form).
- 3) Path loss for the measurement included.
- 4) Set the PSA Resolution Bandwidth as per rules part.
- 5) Set the Ref offset from the pathloss offset calibration file.
- 6) Adjust the center frequency of the spectrum analyzer for incremental coverage of the range from:
 - a. 9 KHz to $F_c - \text{Test Bandwidth}$
 - b. $F_c + \text{Test Bandwidth}$ to $2F_c - 5\text{MHz}$.
- 7) Key up the DUT, Peak Search the highest Spur and record the levels of spurious emissions
- 8) Dekey the DUT.
- 9) Turn On High Pass Filter path and Key up the DUT.
- 10) Adjust the PSA Freq for incremental coverage of range from $2F_c$ to $10F_c$
- 11) Key up the DUT and record the highest spur levels of spurious emissions.

6.10.2. Test Result (Analog)
Analog: 400.0125 MHz, 12.5kHz Channel Spacing, Max Power
Part90,RSS 119

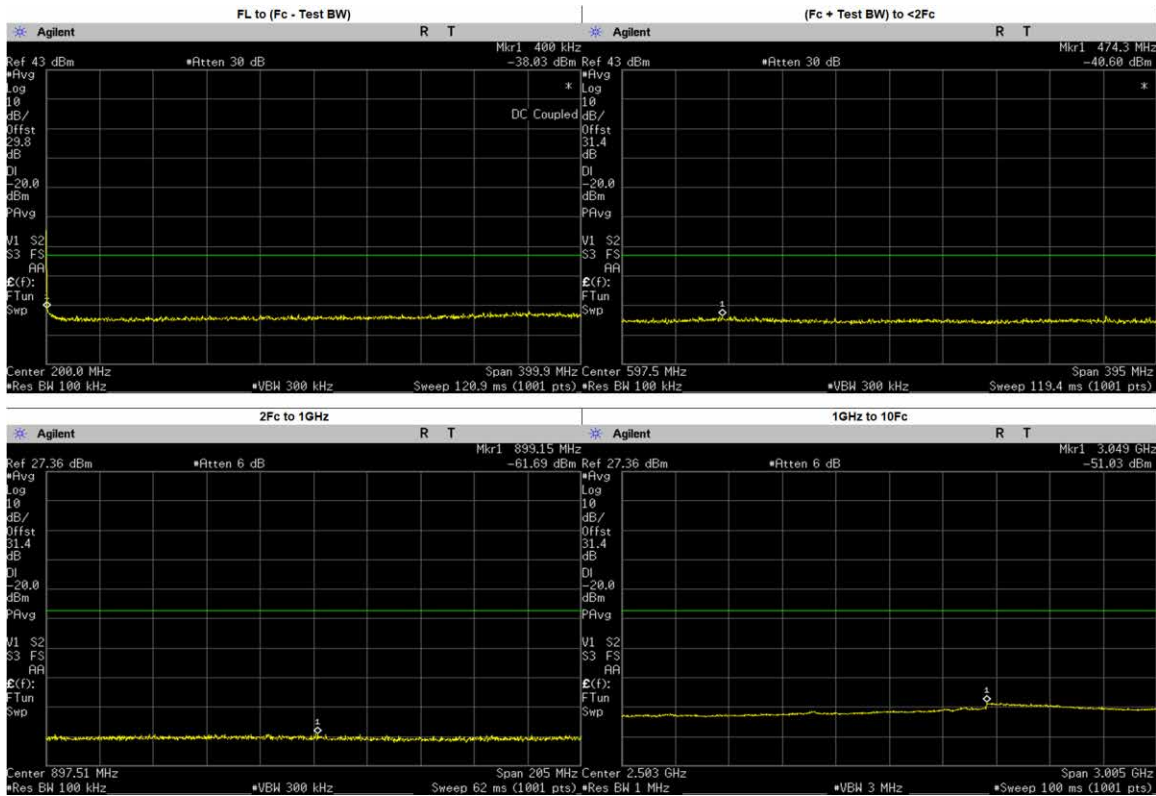

Frequency Range	Highest Spur Frequency (MHz)	Spurious Level (dBm)	Failing Limit (dBm)	Results
FL to (Fc - Test BW)	361.1619	-37.51	-20	PASS
(Fc + Test BW) to <2Fc	474.3200	-40.60	-20	PASS
2Fc to 1GHz	899.1523	-61.69	-20	PASS
	800.0250	-63.01	-20	PASS
1GHz to 10Fc	3049.4950	-51.03	-20	PASS
	1200.0370	-55.81	-20	PASS
	1600.0500	-55.50	-20	PASS
	2000.0620	-54.94	-20	PASS
	2400.0750	-54.53	-20	PASS
	2800.0880	-53.65	-20	PASS
	3200.1000	-51.83	-20	PASS
	3600.1130	-53.11	-20	PASS
	4000.1250	-53.27	-20	PASS

**Analog: 400.0125 MHz, 12.5kHz Channel Spacing, Low Power
 Part90.RSS 119**

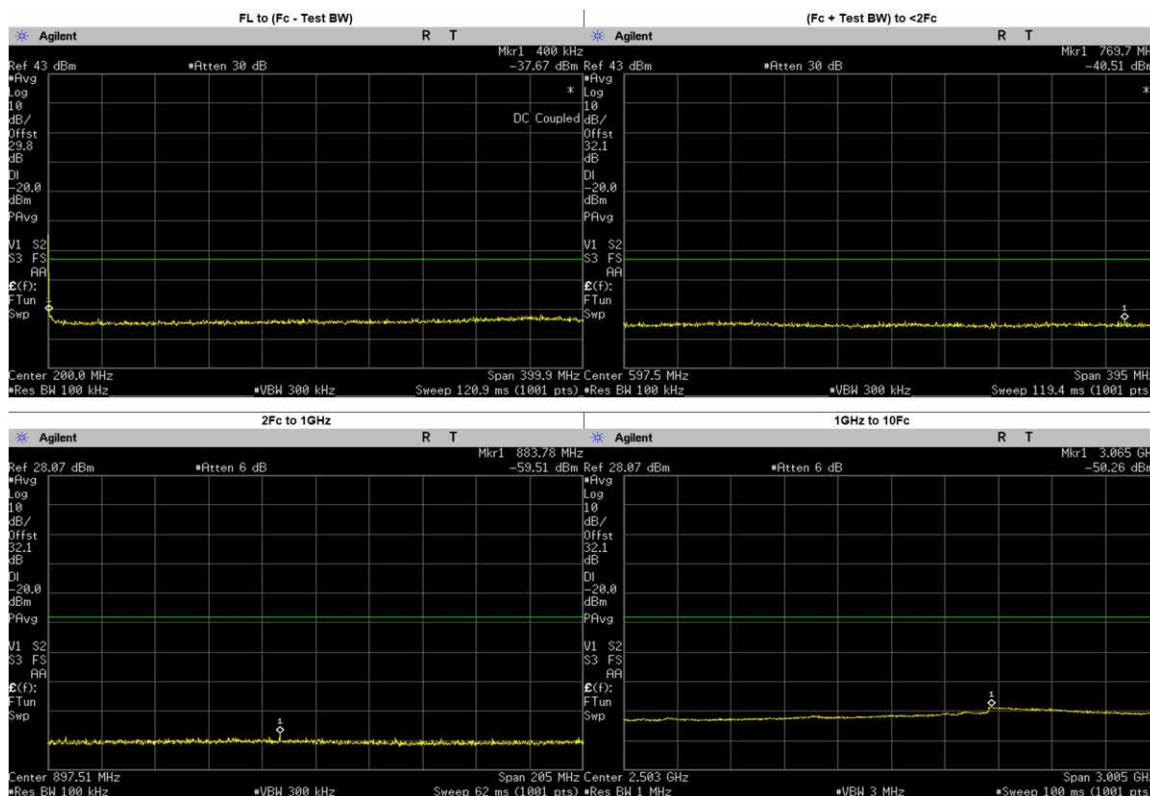

Frequency Range	Highest Spur Frequency (MHz)	Spurious Level (dBm)	Failing Limit (dBm)	Results
FL to (Fc - Test BW)	368.3610	-37.18	-20	PASS
(Fc + Test BW) to <2Fc	769.7478	-40.51	-20	PASS
2Fc to 1GHz	883.7792	-59.51	-20	PASS
	800.0250	-62.35	-20	PASS
1GHz to 10Fc	3064.5210	-50.26	-20	PASS
	1200.0370	-54.81	-20	PASS
	1600.0500	-54.78	-20	PASS
	2000.0620	-53.90	-20	PASS
	2400.0750	-53.72	-20	PASS
	2800.0880	-52.94	-20	PASS
	3200.1000	-51.19	-20	PASS
	3600.1130	-51.98	-20	PASS
4000.1250	-52.52	-20	PASS	

Analog: 406.2 MHz, 12.5kHz Channel Spacing, Max Power
(Not For FCC Review)

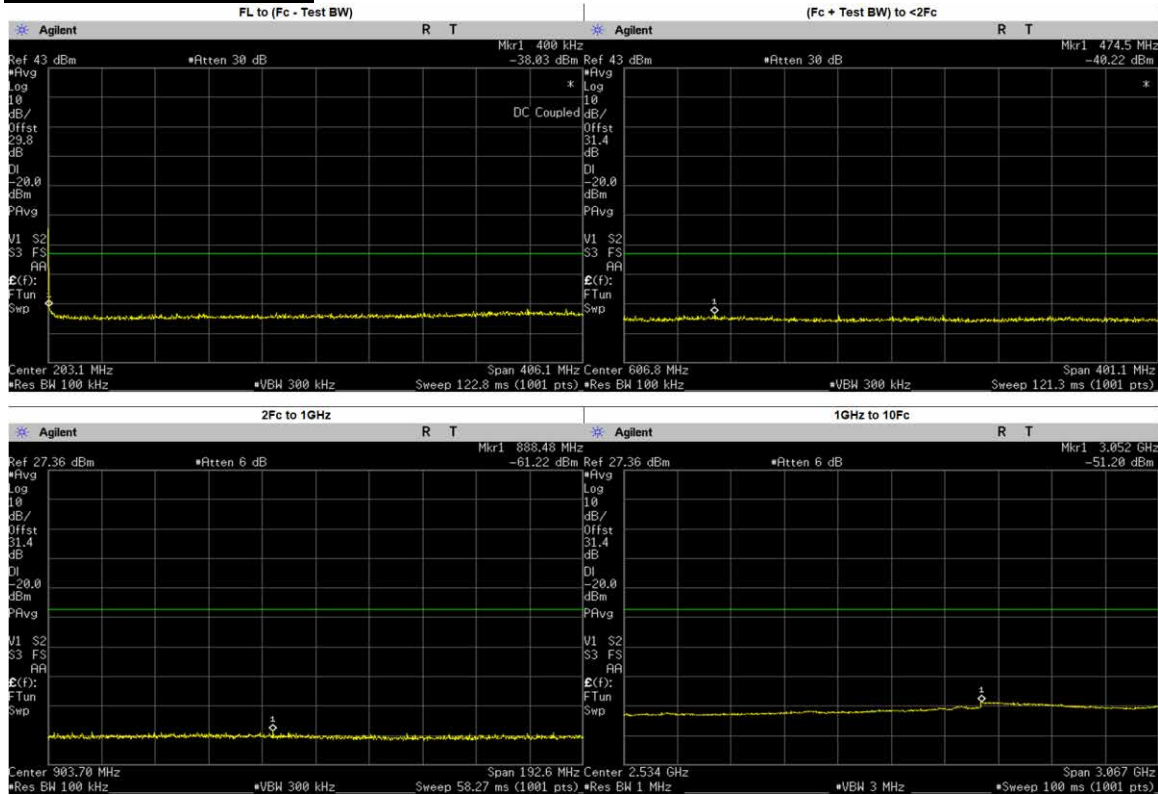

Frequency Range	Highest Spur Frequency (MHz)	Spurious Level (dBm)	Failing Limit (dBm)	Results
FL to (Fc - Test BW)	393.1480	-37.12	-20	PASS
(Fc + Test BW) to <2Fc	474.4502	-40.22	-20	PASS
2Fc to 1GHz	888.4846	-61.22	-20	PASS
	812.4000	-63.55	-20	PASS
1GHz to 10Fc	3051.8230	-51.20	-20	PASS
	1218.6000	-55.12	-20	PASS
	1624.8000	-55.46	-20	PASS
	2031.0000	-54.64	-20	PASS
	2437.2000	-54.44	-20	PASS
	2843.4000	-53.58	-20	PASS
	3249.6000	-52.04	-20	PASS
	3655.8000	-53.04	-20	PASS
4062.0000	-52.84	-20	PASS	

**Analog: 450.025 MHz, 12.5kHz Channel Spacing, Max Power
 FCC Part 90, RSS 119**

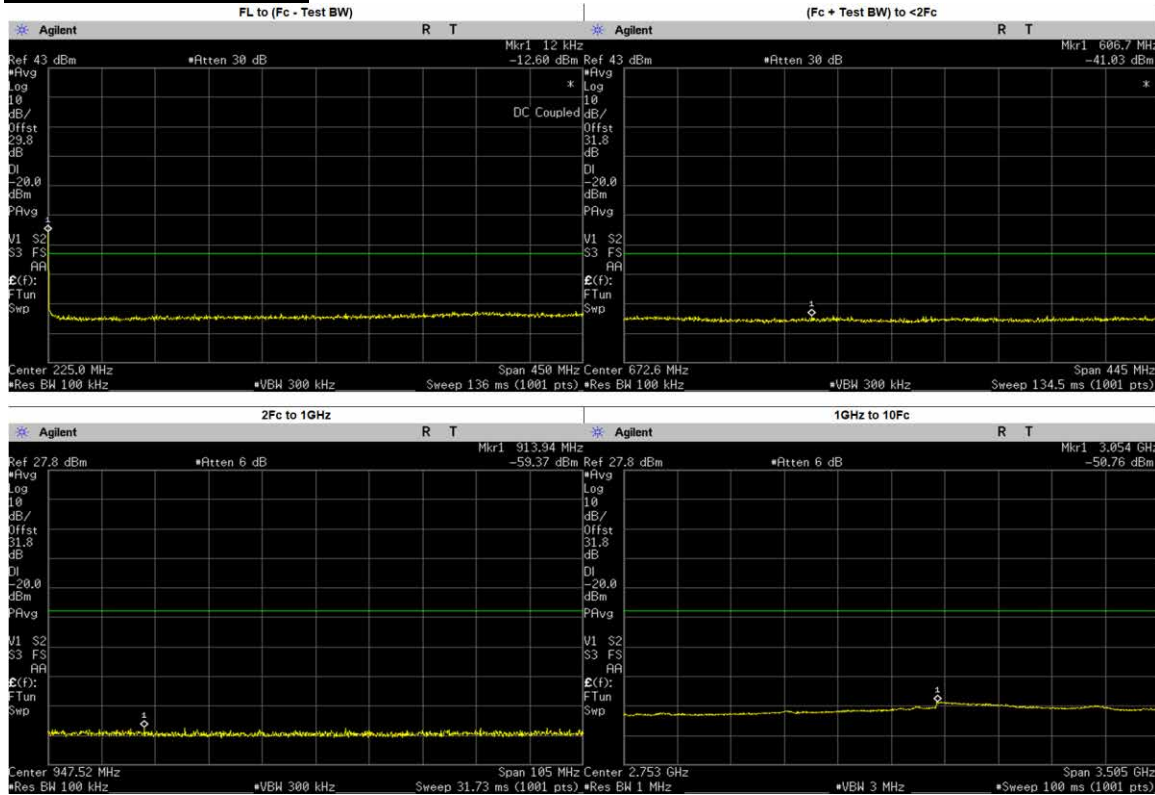

Frequency Range	Highest Spur Frequency (MHz)	Spurious Level (dBm)	Failing Limit (dBm)	Results
FL to (Fc - Test BW)	387.8738	-38.05	-20	PASS
(Fc + Test BW) to <2Fc	606.7106	-41.03	-20	PASS
2Fc to 1GHz	913.9410	-59.37	-20	PASS
	900.0500	-61.50	-20	PASS
1GHz to 10Fc	3054.0770	-50.76	-20	PASS
	1350.0750	-55.01	-20	PASS
	1800.1000	-54.66	-20	PASS
	2250.1250	-54.44	-20	PASS
	2700.1500	-53.40	-20	PASS
	3150.1750	-51.32	-20	PASS
	3600.2000	-52.41	-20	PASS
	4050.2250	-52.54	-20	PASS
	4500.2500	-53.51	-20	PASS

**Analog: 450.025 MHz, 12.5kHz Channel Spacing, Low Power
 FCC Part 90, RSS 119**

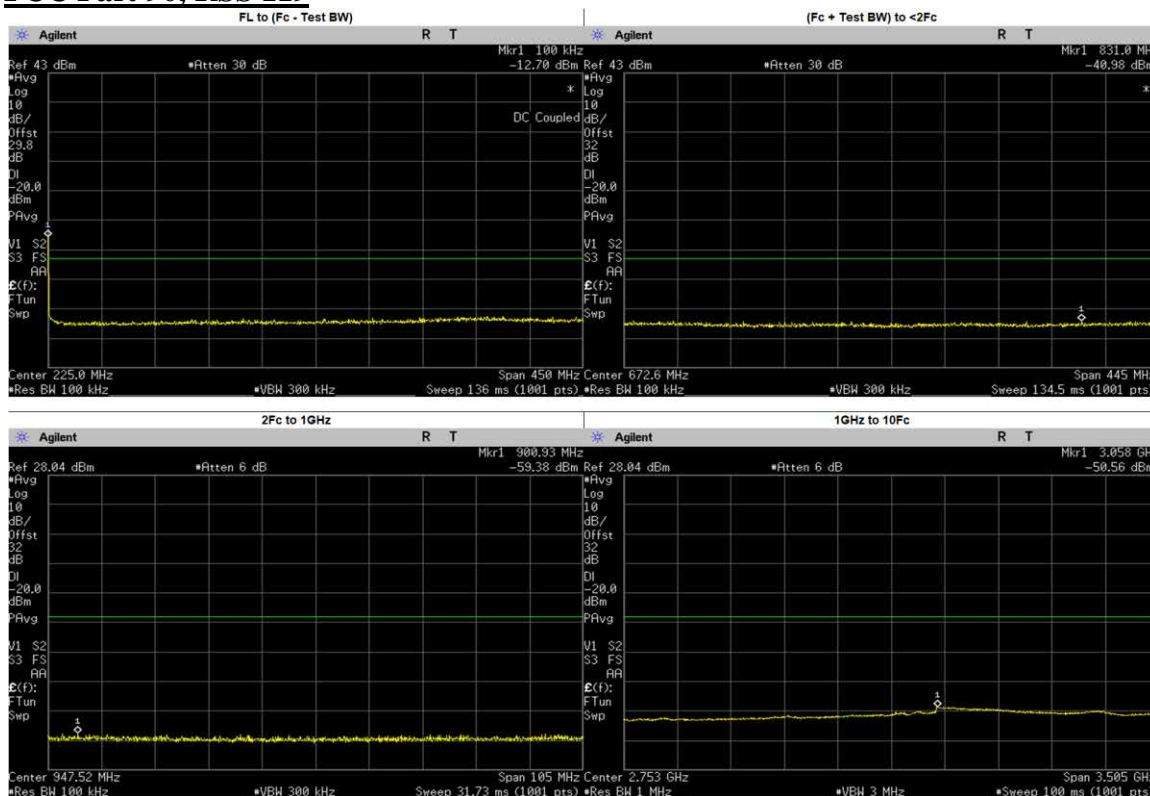

Frequency Range	Highest Spur Frequency (MHz)	Spurious Level (dBm)	Failing Limit (dBm)	Results
FL to (Fc - Test BW)	382.9243	-37.82	-20	PASS
(Fc + Test BW) to <2Fc	830.9746	-40.98	-20	PASS
2Fc to 1GHz	900.9272	-59.38	-20	PASS
	900.0500	-61.25	-20	PASS
1GHz to 10Fc	3057.5820	-50.56	-20	PASS
	1350.0750	-54.82	-20	PASS
	1800.1000	-54.45	-20	PASS
	2250.1250	-54.28	-20	PASS
	2700.1500	-53.54	-20	PASS
	3150.1750	-50.91	-20	PASS
	3600.2000	-52.20	-20	PASS
	4050.2250	-52.33	-20	PASS
4500.2500	-53.06	-20	PASS	

**Analog: 459.125 MHz, 12.5kHz Channel Spacing, Max Power
 FCC Part 90, RSS 119**

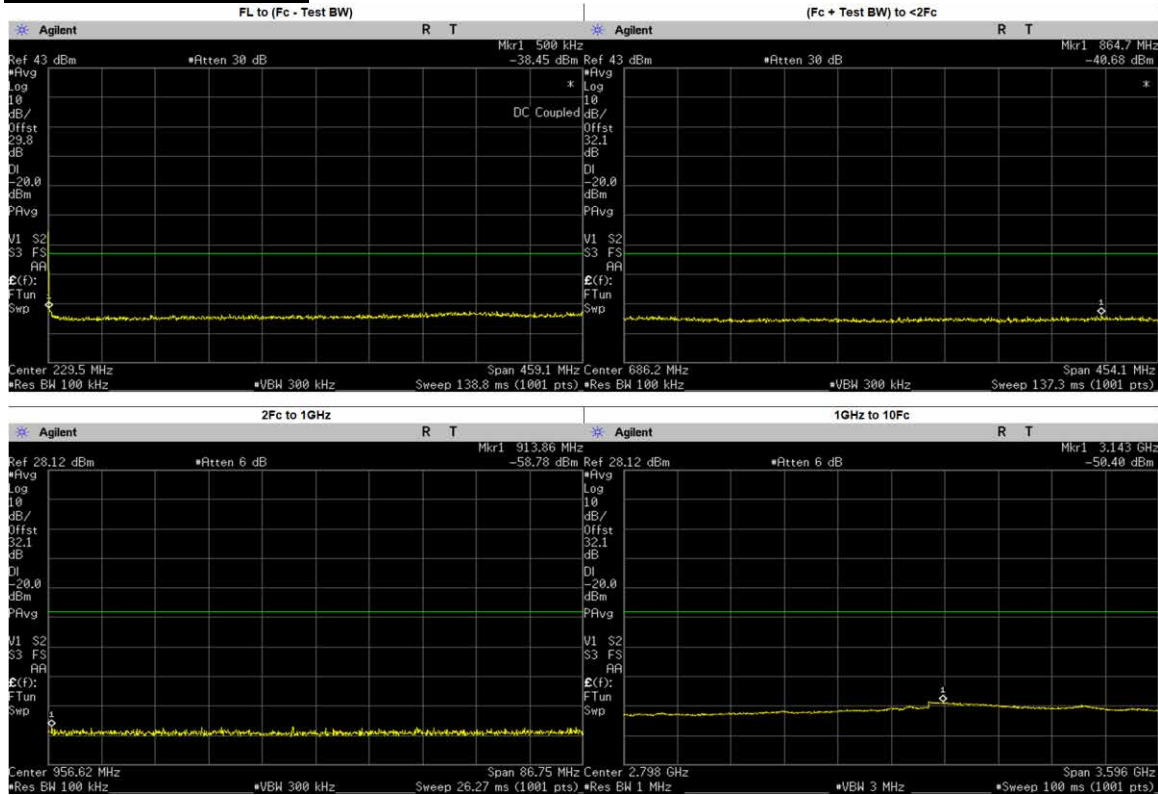

Frequency Range	Highest Spur Frequency (MHz)	Spurious Level (dBm)	Failing Limit (dBm)	Results
FL to (Fc - Test BW)	398.9314	-38.07	-20	PASS
(Fc + Test BW) to <2Fc	864.6647	-40.68	-20	PASS
2Fc to 1GHz	913.8573	-58.78	-20	PASS
	918.2500	-61.21	-20	PASS
1GHz to 10Fc	3143.3650	-50.40	-20	PASS
	1377.3750	-54.74	-20	PASS
	1836.5000	-54.40	-20	PASS
	2295.6250	-54.12	-20	PASS
	2754.7500	-53.10	-20	PASS
	3213.8750	-51.00	-20	PASS
	3673.0000	-52.48	-20	PASS
	4132.1250	-52.13	-20	PASS
	4591.2500	-53.52	-20	PASS

**Analog: 467.775 MHz, 12.5kHz Channel Spacing, Max Power
 FCC Part 90, RSS 119**

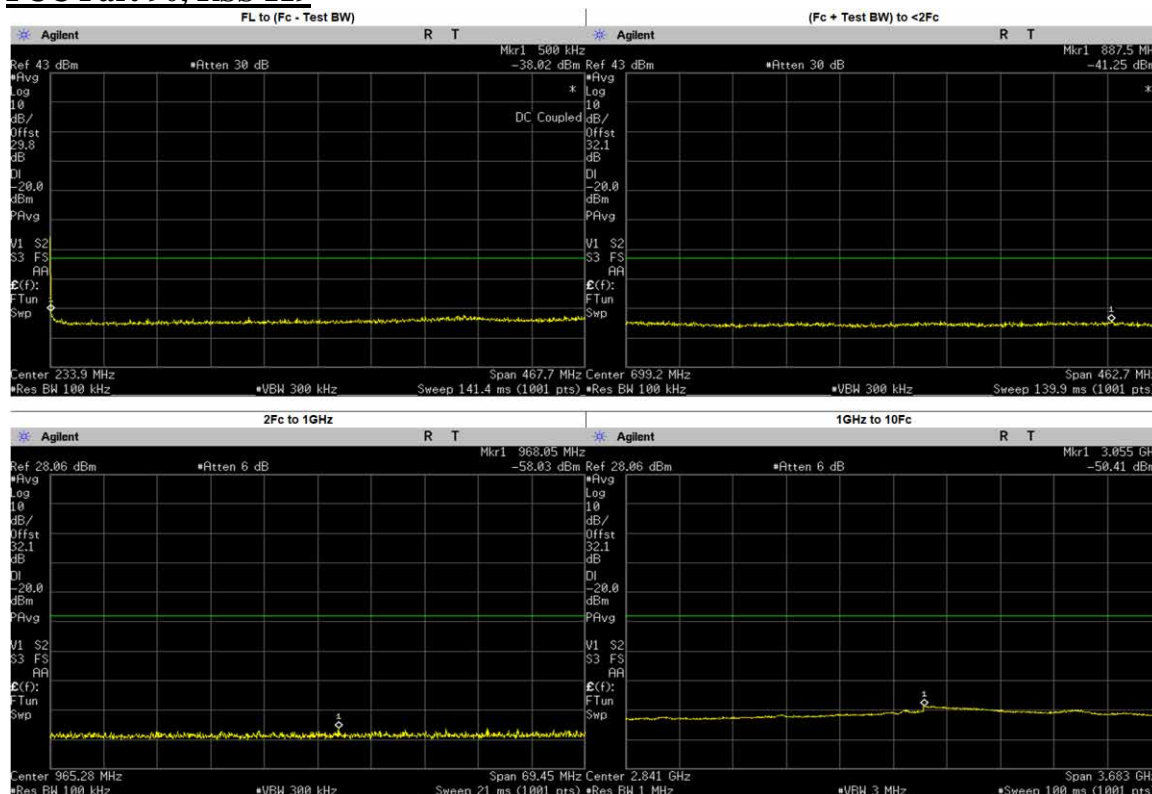

Frequency Range	Highest Spur Frequency (MHz)	Spurious Level (dBm)	Failing Limit (dBm)	Results
FL to (Fc - Test BW)	361.5482	-37.81	-20	PASS
(Fc + Test BW) to <2Fc	887.5172	-41.25	-20	PASS
2Fc to 1GHz	968.0530	-58.03	-20	PASS
	935.5500	-59.92	-20	PASS
1GHz to 10Fc	3054.9740	-50.41	-20	PASS
	1403.3250	-54.74	-20	PASS
	1871.1000	-54.60	-20	PASS
	2338.8750	-54.03	-20	PASS
	2806.6500	-52.84	-20	PASS
	3274.4250	-51.27	-20	PASS
	3742.2000	-52.45	-20	PASS
	4209.9750	-53.07	-20	PASS
	4677.7500	-53.64	-20	PASS

**Analog: 467.775 MHz, 12.5kHz Channel Spacing, Low Power
 FCC Part 90, RSS 119**

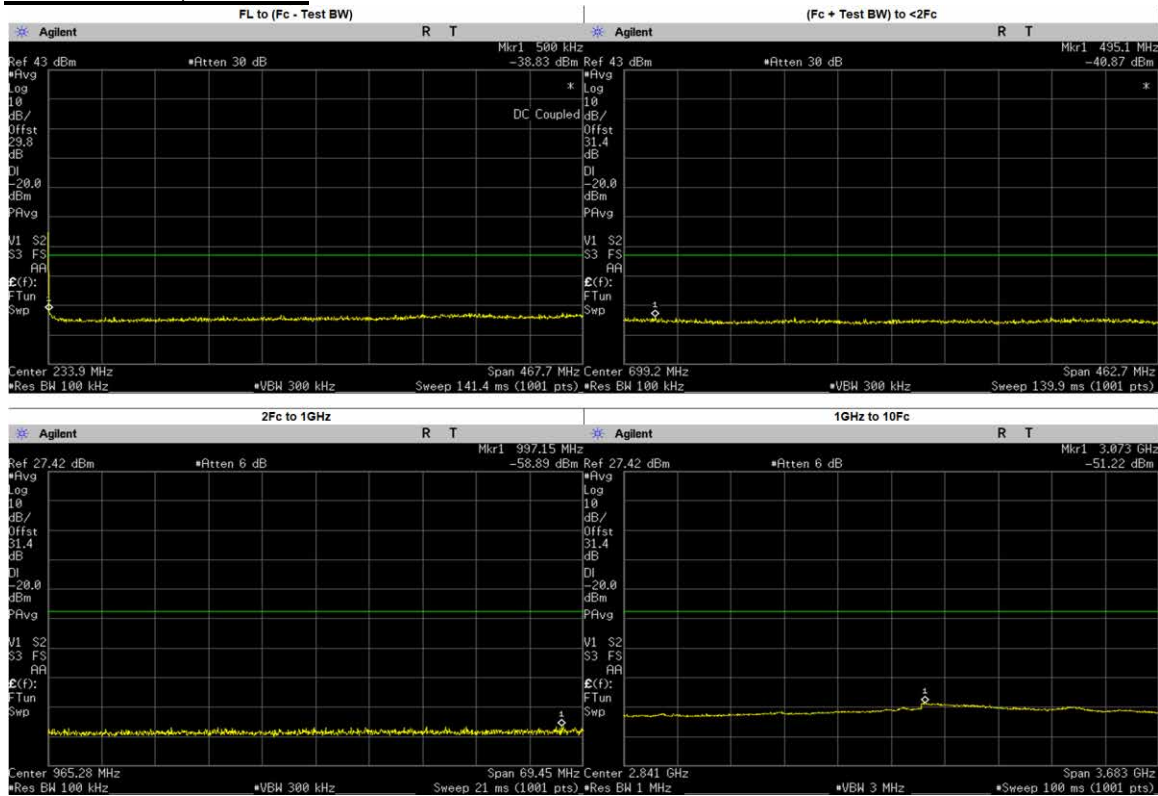

Frequency Range	Highest Spur Frequency (MHz)	Spurious Level (dBm)	Failing Limit (dBm)	Results
FL to (Fc - Test BW)	449.9453	-37.96	-20	PASS
(Fc + Test BW) to <2Fc	495.1322	-40.87	-20	PASS
2Fc to 1GHz	997.1526	-58.89	-20	PASS
	935.5500	-61.11	-20	PASS
1GHz to 10Fc	3073.3880	-51.22	-20	PASS
	1403.3250	-55.57	-20	PASS
	1871.1000	-55.02	-20	PASS
	2338.8750	-54.54	-20	PASS
	2806.6500	-53.44	-20	PASS
	3274.4250	-52.17	-20	PASS
	3742.2000	-53.21	-20	PASS
	4209.9750	-53.57	-20	PASS
	4677.7500	-54.29	-20	PASS

**Analog: 469.9875 MHz, 12.5kHz Channel Spacing, Max Power
 FCC Part 90, RSS 119**

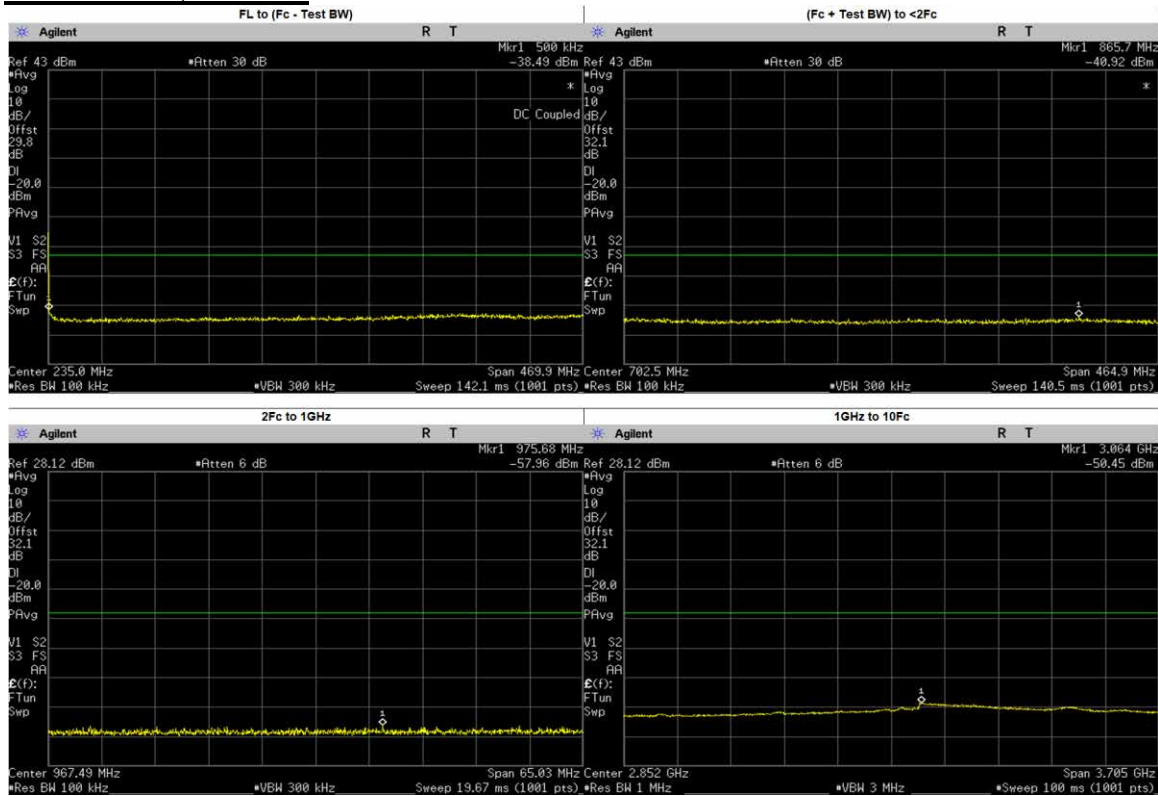

Frequency Range	Highest Spur Frequency (MHz)	Spurious Level (dBm)	Failing Limit (dBm)	Results
FL to (Fc - Test BW)	384.4050	-38.14	-20	PASS
(Fc + Test BW) to <2Fc	865.7003	-40.92	-20	PASS
2Fc to 1GHz	975.6807	-57.96	-20	PASS
	939.9750	-60.05	-20	PASS
1GHz to 10Fc	3063.6150	-50.45	-20	PASS
	1409.9630	-54.89	-20	PASS
	1879.9500	-54.46	-20	PASS
	2349.9370	-53.89	-20	PASS
	2819.9250	-52.73	-20	PASS
	3289.9120	-51.30	-20	PASS
	3759.9000	-52.53	-20	PASS
	4229.8870	-52.99	-20	PASS
	4699.8750	-53.79	-20	PASS

**Analog: 469.9875 MHz, 12.5kHz Channel Spacing, Low Power
 FCC Part 90, RSS 119**

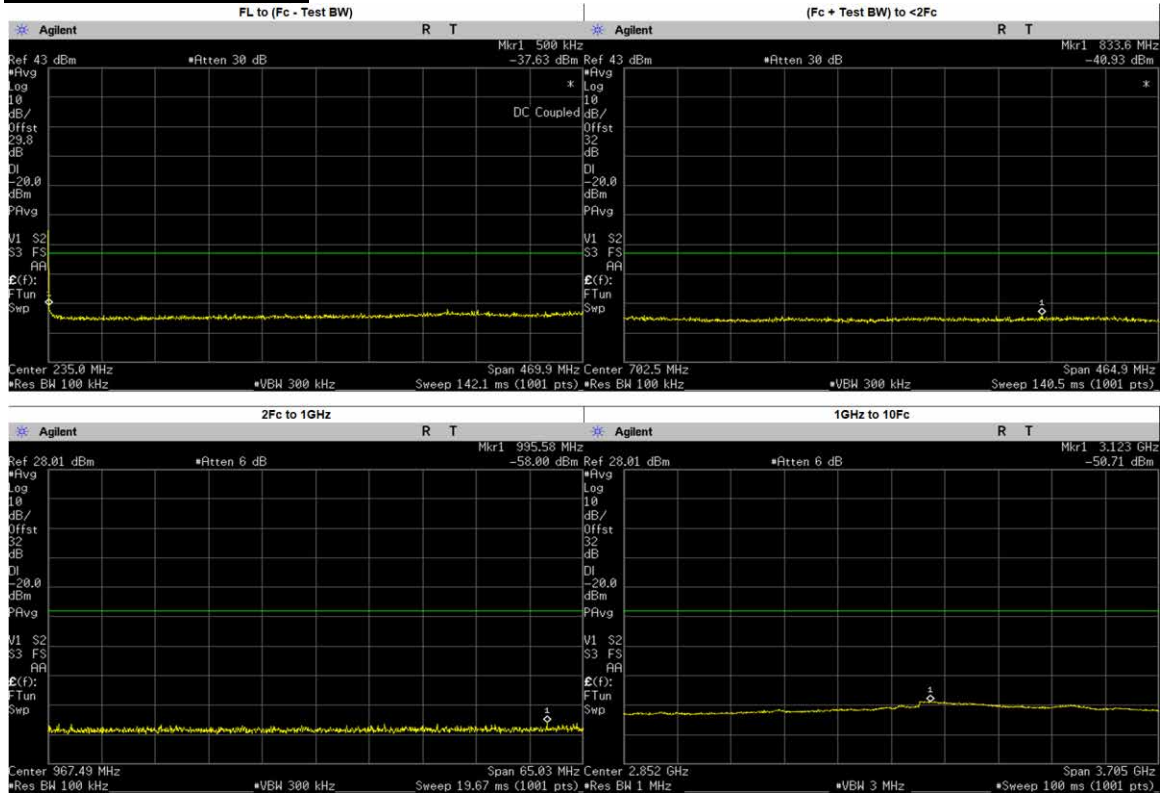

Frequency Range	Highest Spur Frequency (MHz)	Spurious Level (dBm)	Failing Limit (dBm)	Results
FL to (Fc - Test BW)	377.3561	-37.68	-20	PASS
(Fc + Test BW) to <2Fc	833.6201	-40.93	-20	PASS
2Fc to 1GHz	995.5783	-58.00	-20	PASS
	939.9750	-61.47	-20	PASS
1GHz to 10Fc	3122.8930	-50.71	-20	PASS
	1409.9630	-54.94	-20	PASS
	1879.9500	-54.37	-20	PASS
	2349.9370	-53.93	-20	PASS
	2819.9250	-52.73	-20	PASS
	3289.9120	-51.50	-20	PASS
	3759.9000	-52.28	-20	PASS
	4229.8870	-52.86	-20	PASS
4699.8750	-53.89	-20	PASS	

**Analog: 400.0125 MHz, 25.0kHz Channel Spacing, Max Power
 FCC Part 90, RSS 119**

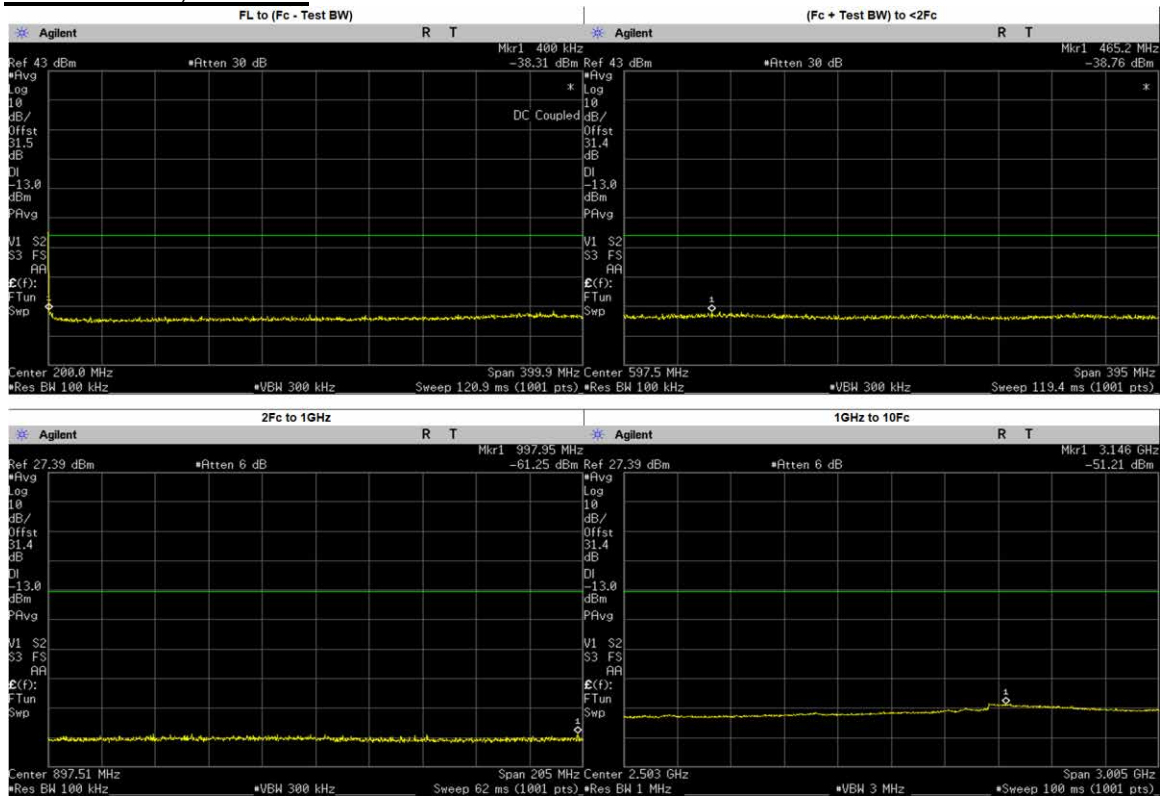

Frequency Range	Highest Spur Frequency (MHz)	Spurious Level (dBm)	Failing Limit (dBm)	Results
FL to (Fc - Test BW)	377.5598	-38.58	-13	PASS
(Fc + Test BW) to <2Fc	465.2360	-38.76	-13	PASS
2Fc to 1GHz	997.9502	-61.25	-13	PASS
	800.0250	-62.78	-13	PASS
1GHz to 10Fc	3145.6590	-51.21	-13	PASS
	1200.0370	-55.61	-13	PASS
	1600.0500	-55.54	-13	PASS
	2000.0620	-54.60	-13	PASS
	2400.0750	-54.50	-13	PASS
	2800.0880	-53.53	-13	PASS
	3200.1000	-51.89	-13	PASS
	3600.1130	-52.72	-13	PASS
4000.1250	-53.15	-13	PASS	

**Analog: 400.0125 MHz, 25.0kHz Channel Spacing, Low Power
 FCC Part 90, RSS 119**

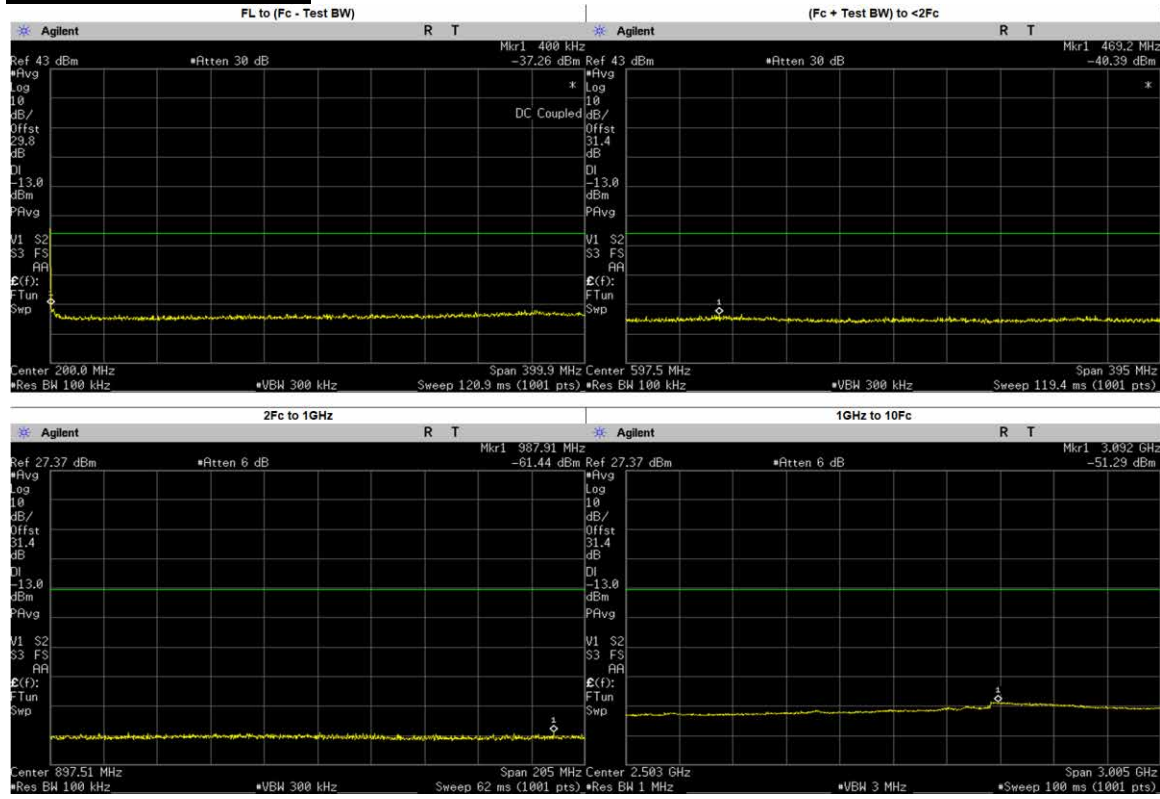

Frequency Range	Highest Spur Frequency (MHz)	Spurious Level (dBm)	Failing Limit (dBm)	Results
FL to (Fc - Test BW)	355.1627	-38.89	-13	PASS
(Fc + Test BW) to <2Fc	469.1856	-40.39	-13	PASS
2Fc to 1GHz	987.9065	-61.44	-13	PASS
	800.0250	-63.05	-13	PASS
1GHz to 10Fc	3091.5670	-51.29	-13	PASS
	1200.0370	-55.67	-13	PASS
	1600.0500	-55.46	-13	PASS
	2000.0620	-55.00	-13	PASS
	2400.0750	-54.58	-13	PASS
	2800.0880	-53.71	-13	PASS
	3200.1000	-51.68	-13	PASS
	3600.1130	-53.01	-13	PASS
4000.1250	-53.25	-13	PASS	

Analog: 406.2 MHz, 25.0kHz Channel Spacing, Max Power
(Not For FCC Review)

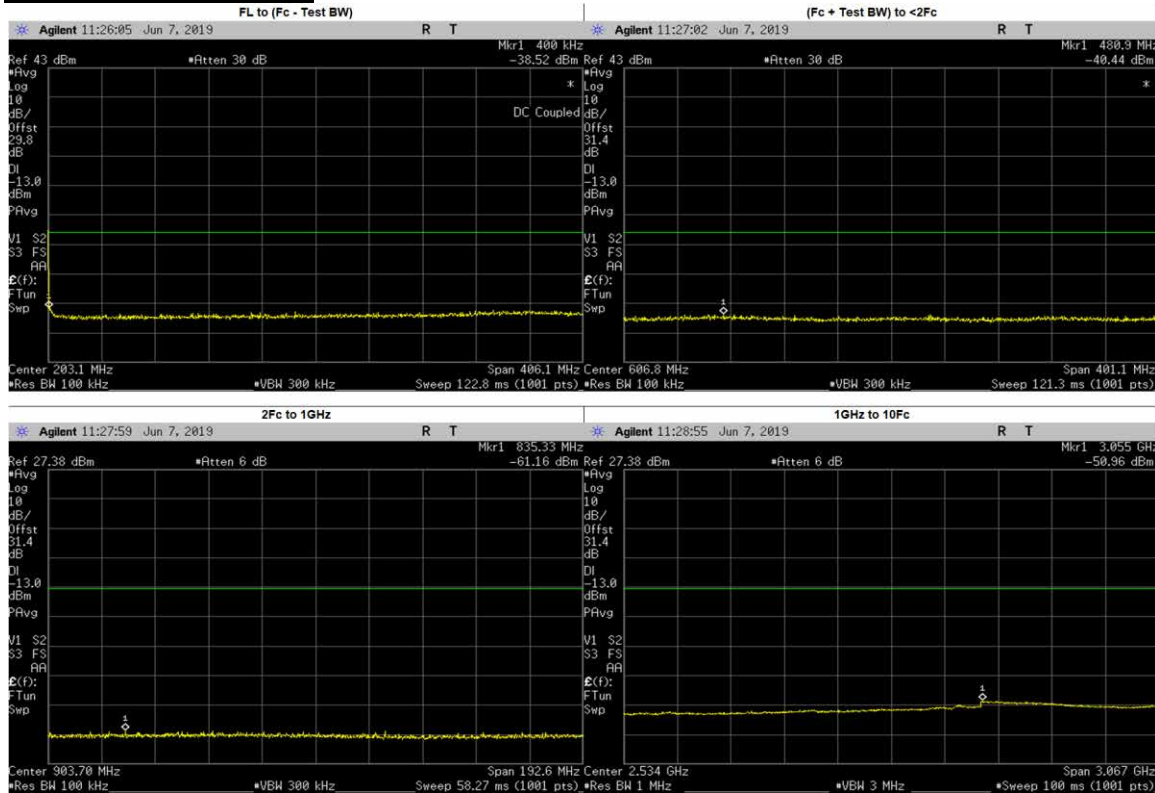

Frequency Range	Highest Spur Frequency (MHz)	Spurious Level (dBm)	Failing Limit (dBm)	Results
FL to (Fc - Test BW)	337.9136	-39.30	-13	PASS
(Fc + Test BW) to <2Fc	480.8685	-40.44	-13	PASS
2Fc to 1GHz	835.3270	-61.16	-13	PASS
	812.4000	-63.03	-13	PASS
1GHz to 10Fc	3054.8900	-50.96	-13	PASS
	1218.6000	-55.42	-13	PASS
	1624.8000	-55.37	-13	PASS
	2031.0000	-54.91	-13	PASS
	2437.2000	-54.38	-13	PASS
	2843.4000	-53.66	-13	PASS
	3249.6000	-52.03	-13	PASS
	3655.8000	-53.10	-13	PASS
4062.0000	-52.96	-13	PASS	

**Analog: 450.025 MHz, 25.0kHz Channel Spacing, Max Power
 FCC Part 90, RSS 119**

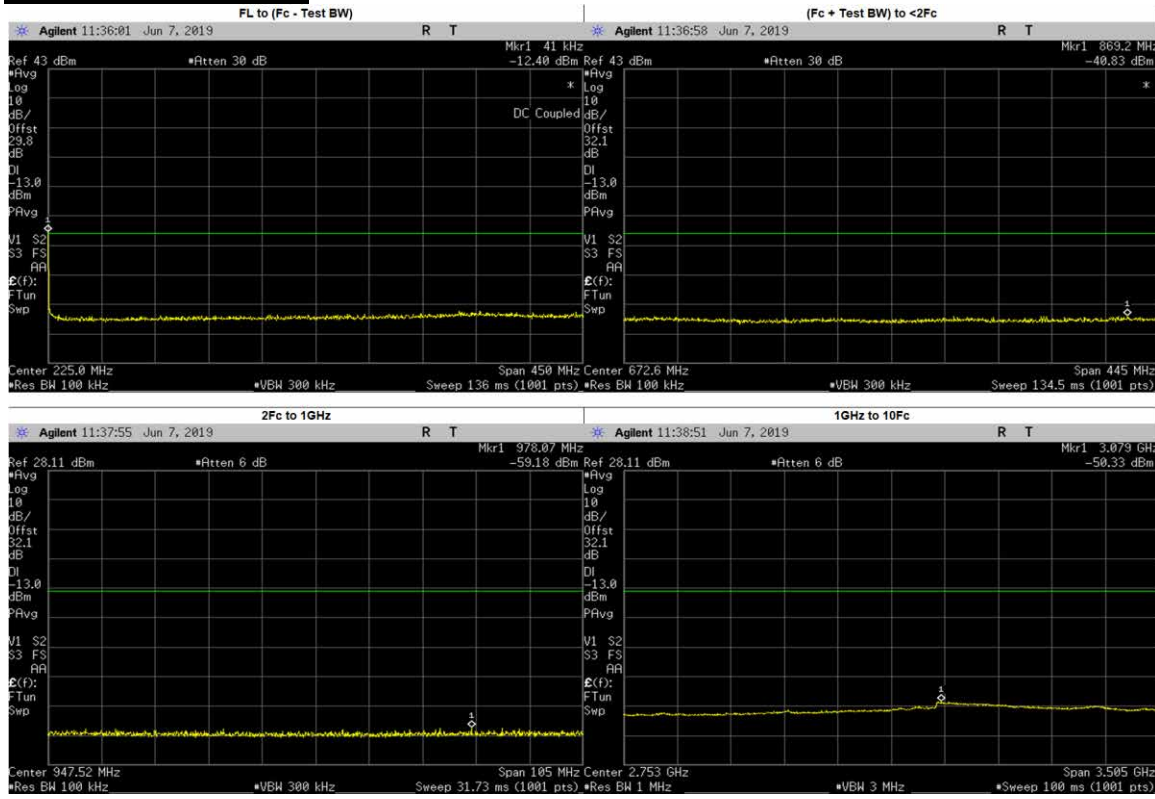

Frequency Range	Highest Spur Frequency (MHz)	Spurious Level (dBm)	Failing Limit (dBm)	Results
FL to (Fc - Test BW)	345.5777	-39.12	-13	PASS
(Fc + Test BW) to <2Fc	869.2418	-40.83	-13	PASS
2Fc to 1GHz	978.0655	-59.18	-13	PASS
	900.0500	-61.43	-13	PASS
1GHz to 10Fc	3078.6130	-50.33	-13	PASS
	1350.0750	-54.72	-13	PASS
	1800.1000	-54.39	-13	PASS
	2250.1250	-54.08	-13	PASS
	2700.1500	-53.56	-13	PASS
	3150.1750	-50.91	-13	PASS
	3600.2000	-52.09	-13	PASS
	4050.2250	-52.23	-13	PASS
	4500.2500	-52.93	-13	PASS

**Analog: 450.025 MHz, 25.0kHz Channel Spacing, Low Power
 FCC Part 90, RSS 119**

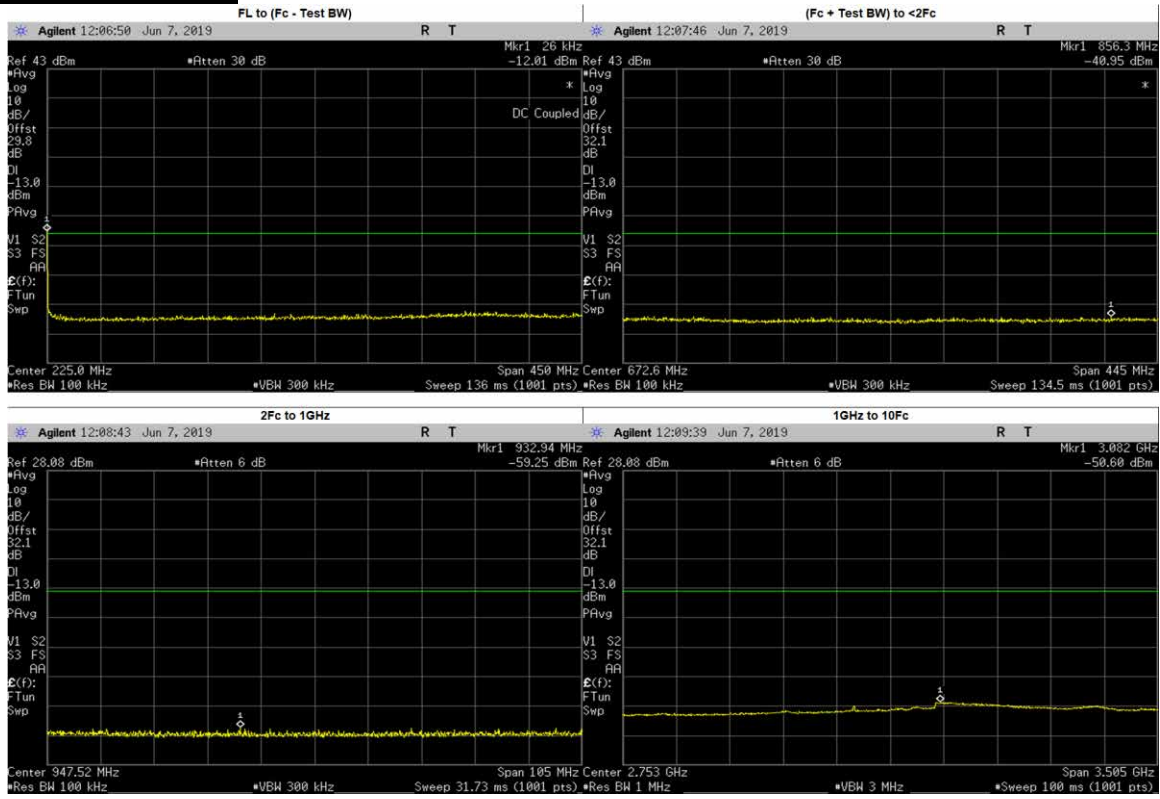

Frequency Range	Highest Spur Frequency (MHz)	Spurious Level (dBm)	Failing Limit (dBm)	Results
FL to (Fc - Test BW)	351.8771	-39.13	-13	PASS
(Fc + Test BW) to <2Fc	856.3378	-40.95	-13	PASS
2Fc to 1GHz	932.9370	-59.25	-13	PASS
	900.0500	-61.24	-13	PASS
1GHz to 10Fc	3082.1190	-50.60	-13	PASS
	1350.0750	-54.93	-13	PASS
	1800.1000	-54.55	-13	PASS
	2250.1250	-54.32	-13	PASS
	2700.1500	-53.25	-13	PASS
	3150.1750	-50.92	-13	PASS
	3600.2000	-52.23	-13	PASS
	4050.2250	-52.29	-13	PASS
	4500.2500	-53.15	-13	PASS

**Analog: 459.125 MHz, 25.0kHz Channel Spacing, Max Power
 FCC Part 90, RSS 119**

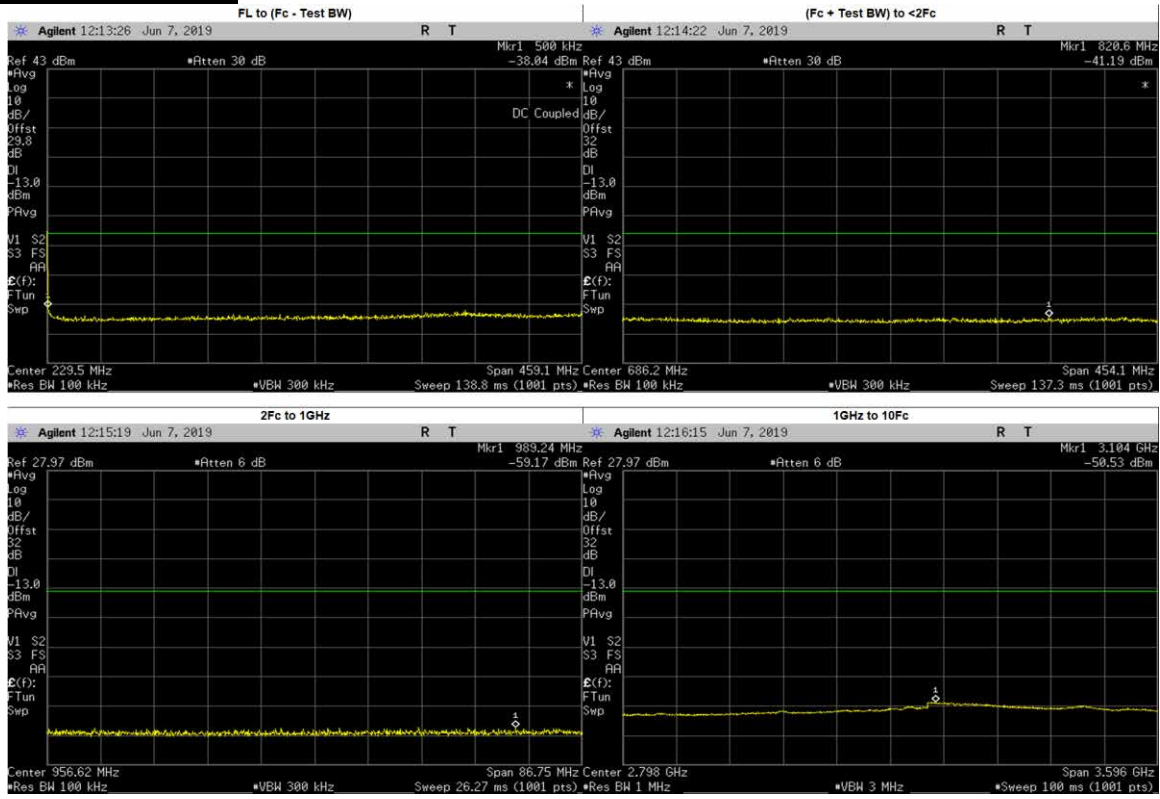

Frequency Range	Highest Spur Frequency (MHz)	Spurious Level (dBm)	Failing Limit (dBm)	Results
FL to (Fc - Test BW)	358.9933	-39.10	-13	PASS
(Fc + Test BW) to <2Fc	820.6201	-41.19	-13	PASS
2Fc to 1GHz	989.2430	-59.17	-13	PASS
	918.2500	-60.56	-13	PASS
1GHz to 10Fc	3103.8060	-50.53	-13	PASS
	1377.3750	-55.02	-13	PASS
	1836.5000	-54.64	-13	PASS
	2295.6250	-54.28	-13	PASS
	2754.7500	-53.41	-13	PASS
	3213.8750	-51.07	-13	PASS
	3673.0000	-52.56	-13	PASS
	4132.1250	-52.46	-13	PASS
	4591.2500	-53.68	-13	PASS

**Analog: 467.775 MHz, 25.0kHz Channel Spacing, Max Power
 FCC Part 90, RSS 119**

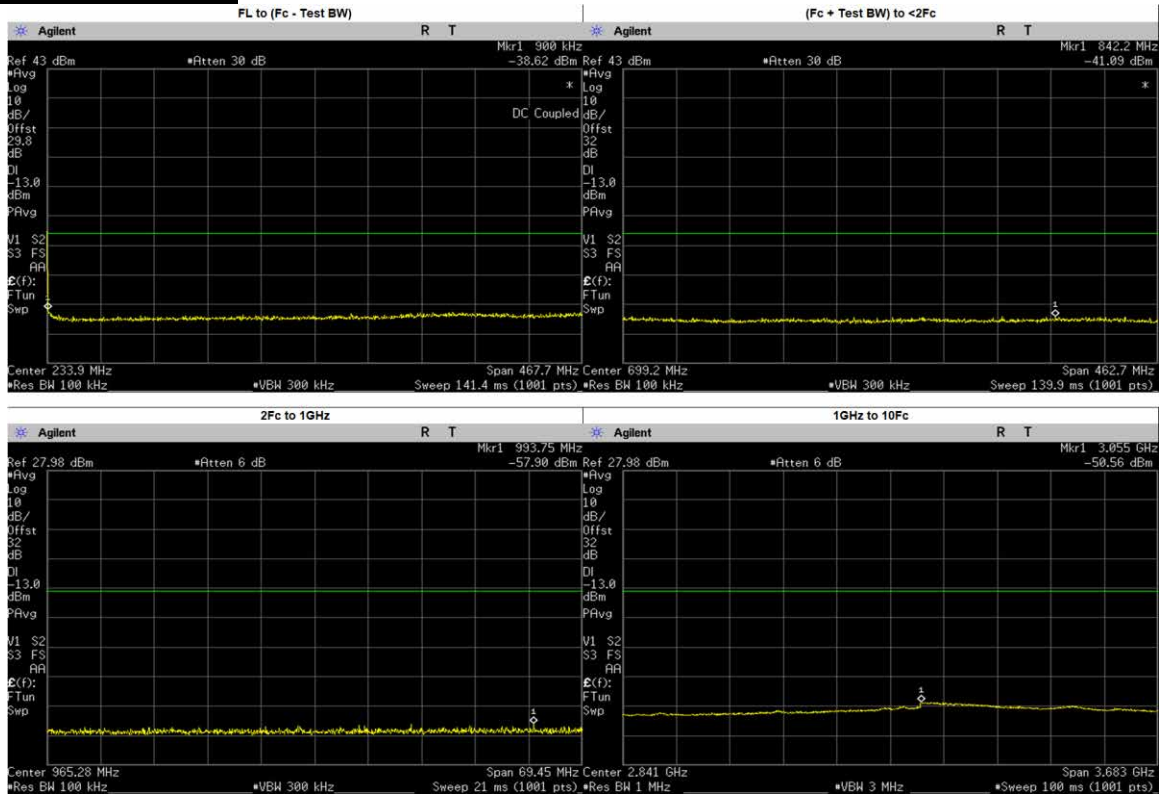

Frequency Range	Highest Spur Frequency (MHz)	Spurious Level (dBm)	Failing Limit (dBm)	Results
FL to (Fc - Test BW)	354.5326	-39.62	-13	PASS
(Fc + Test BW) to <2Fc	842.1708	-41.09	-13	PASS
2Fc to 1GHz	993.7495	-57.90	-13	PASS
	935.5500	-60.79	-13	PASS
1GHz to 10Fc	3054.9740	-50.56	-13	PASS
	1403.3250	-55.00	-13	PASS
	1871.1000	-54.51	-13	PASS
	2338.8750	-54.09	-13	PASS
	2806.6500	-52.99	-13	PASS
	3274.4250	-51.56	-13	PASS
	3742.2000	-52.65	-13	PASS
	4209.9750	-52.93	-13	PASS
	4677.7500	-53.51	-13	PASS

**Analog: 467.775 MHz, 25.0kHz Channel Spacing, Low Power
 FCC Part 90, RSS 119**

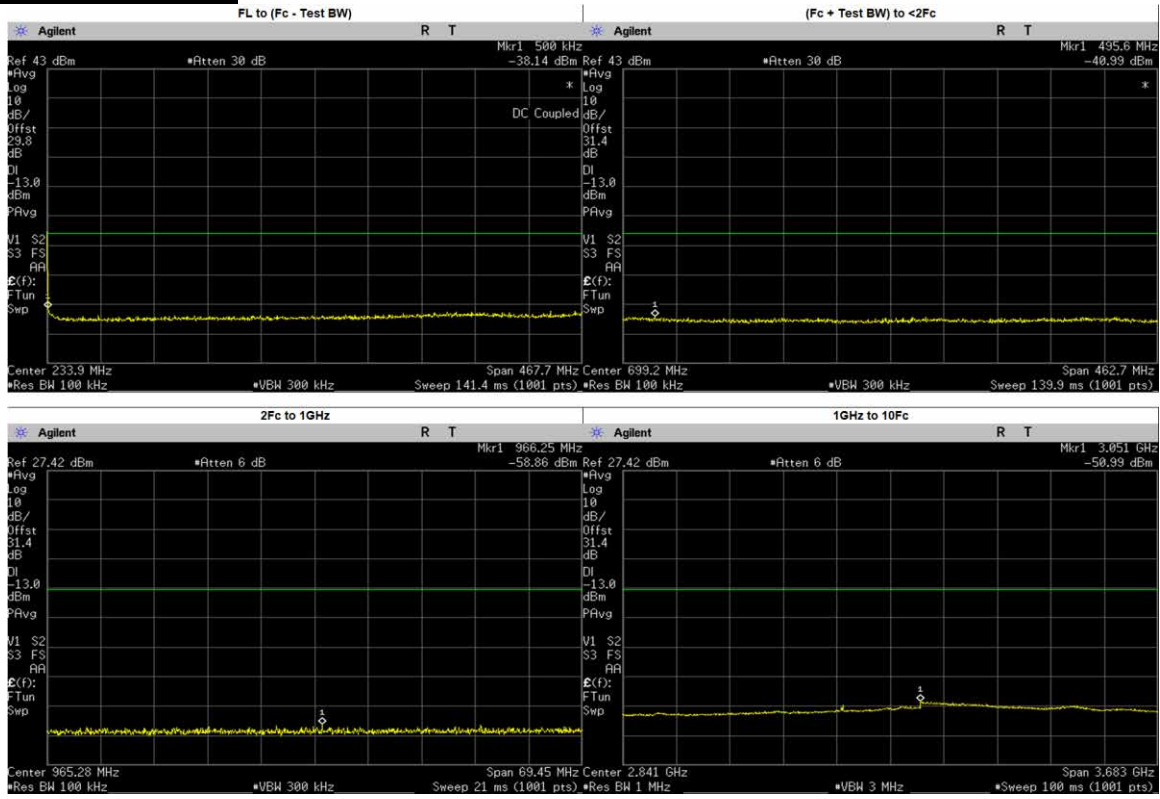

Frequency Range	Highest Spur Frequency (MHz)	Spurious Level (dBm)	Failing Limit (dBm)	Results
FL to (Fc - Test BW)	440.1234	-39.28	-13	PASS
(Fc + Test BW) to <2Fc	495.5949	-40.99	-13	PASS
2Fc to 1GHz	966.2473	-58.86	-13	PASS
	935.5500	-61.81	-13	PASS
1GHz to 10Fc	3051.2920	-50.99	-13	PASS
	1403.3250	-55.44	-13	PASS
	1871.1000	-55.12	-13	PASS
	2338.8750	-54.64	-13	PASS
	2806.6500	-53.59	-13	PASS
	3274.4250	-51.98	-13	PASS
	3742.2000	-53.18	-13	PASS
	4209.9750	-53.49	-13	PASS
	4677.7500	-54.35	-13	PASS

**Analog: 469.9875 MHz, 25.0kHz Channel Spacing, Max Power
 FCC Part 90, RSS 119**

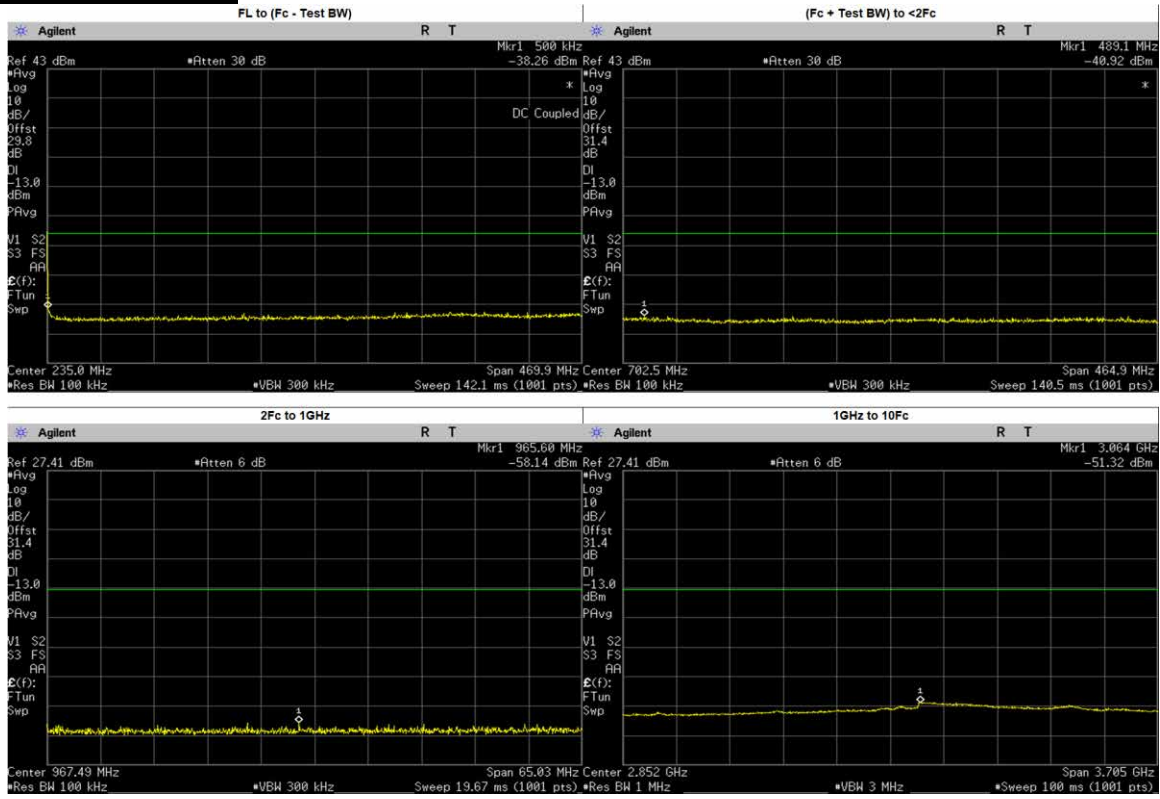

Frequency Range	Highest Spur Frequency (MHz)	Spurious Level (dBm)	Failing Limit (dBm)	Results
FL to (Fc - Test BW)	353.8600	-39.39	-13	PASS
(Fc + Test BW) to <2Fc	489.1065	-40.92	-13	PASS
2Fc to 1GHz	965.6018	-58.14	-13	PASS
	939.9750	-60.07	-13	PASS
1GHz to 10Fc	3063.6150	-51.32	-13	PASS
	1409.9630	-55.59	-13	PASS
	1879.9500	-55.12	-13	PASS
	2349.9370	-54.61	-13	PASS
	2819.9250	-53.36	-13	PASS
	3289.9120	-52.05	-13	PASS
	3759.9000	-53.33	-13	PASS
	4229.8870	-53.77	-13	PASS
	4699.8750	-54.43	-13	PASS

**Analog: 469.9875 MHz, 25.0kHz Channel Spacing, Low Power
 FCC Part 90, RSS 119**

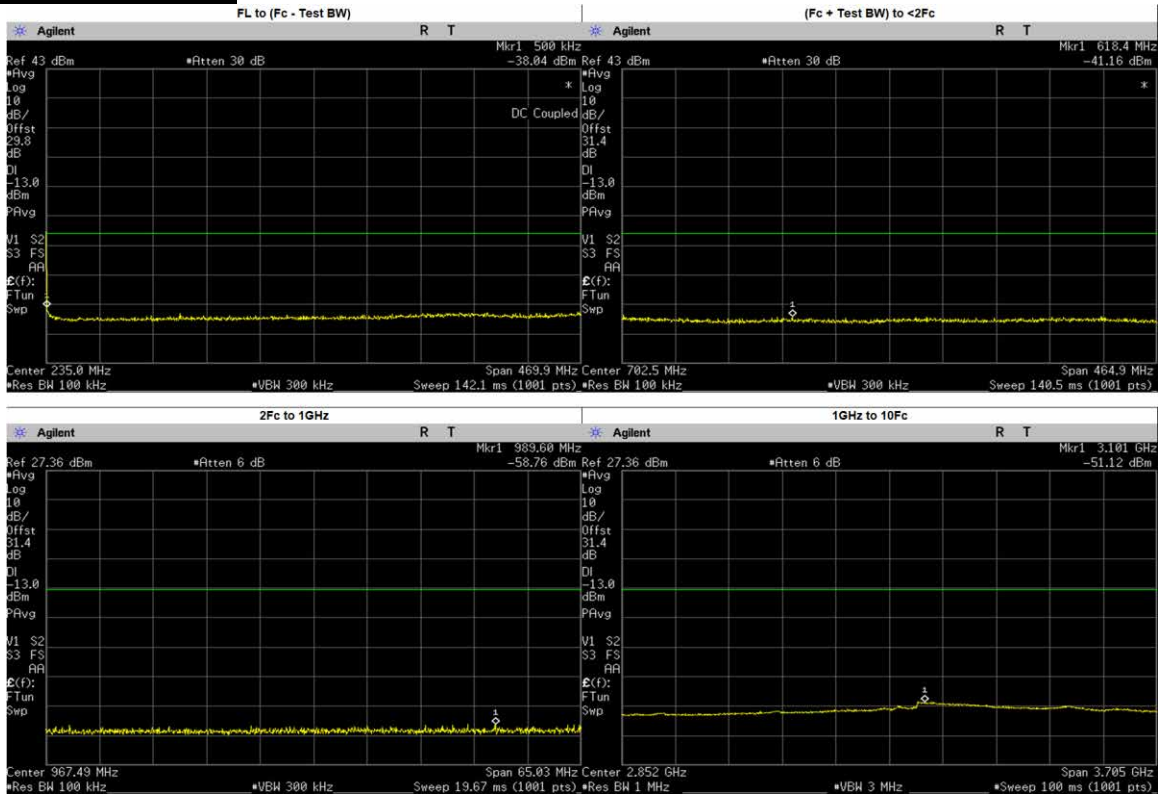

Frequency Range	Highest Spur Frequency (MHz)	Spurious Level (dBm)	Failing Limit (dBm)	Results
FL to (Fc - Test BW)	387.6944	-39.88	-13	PASS
(Fc + Test BW) to <2Fc	618.3572	-41.16	-13	PASS
2Fc to 1GHz	989.5960	-58.76	-13	PASS
	939.9750	-61.34	-13	PASS
1GHz to 10Fc	3100.6640	-51.12	-13	PASS
	1409.9630	-55.74	-13	PASS
	1879.9500	-55.01	-13	PASS
	2349.9370	-54.72	-13	PASS
	2819.9250	-53.65	-13	PASS
	3289.9120	-51.81	-13	PASS
	3759.9000	-53.40	-13	PASS
	4229.8870	-53.72	-13	PASS
	4699.8750	-54.40	-13	PASS

6.10.3. Test Result (Digital)

NA → Not Applicable

6.10.4. Test Limit

Table below summarized the power of any emission outside a licensee’s frequency block shall be attenuated below the transmitter power (P) by at least

Channel Spacing	Part 22	Part 24D	Part 74	Part 80	Part 90 (UHF, VHF, 800, 900)	Part 90 (700)
12.5kHz	43 + log ₁₀ (P) (-13 dBm)	43 + log ₁₀ (P) (-13 dBm)	43 + log ₁₀ (P) (-13 dBm)	Not Applicable	50 + log ₁₀ (P) (-20 dBm)	43 + log ₁₀ (P) (-13 dBm)
25kHz		Not Applicable		43 + log ₁₀ (P) (-13 dBm)	43 + log ₁₀ (P) (-13 dBm)	43 + log ₁₀ (P) (-13 dBm)

Channel Spacing	RSS 134	RSS 182	RSS 119 (UHF, VHF, 800, 900)	RSS 119 (700)
12.5kHz	43 + log ₁₀ (P) (-13 dBm)	Not Applicable	50 + log ₁₀ (P) (-20 dBm)	43 + log ₁₀ (P) (-13 dBm)
25kHz	Not Applicable	43 + log ₁₀ (P) (-13 dBm)	43 + log ₁₀ (P) (-13 dBm)	43 + log ₁₀ (P) (-13 dBm)

6.11. Radiated Spurious Emission

6.11.1. Test Setup

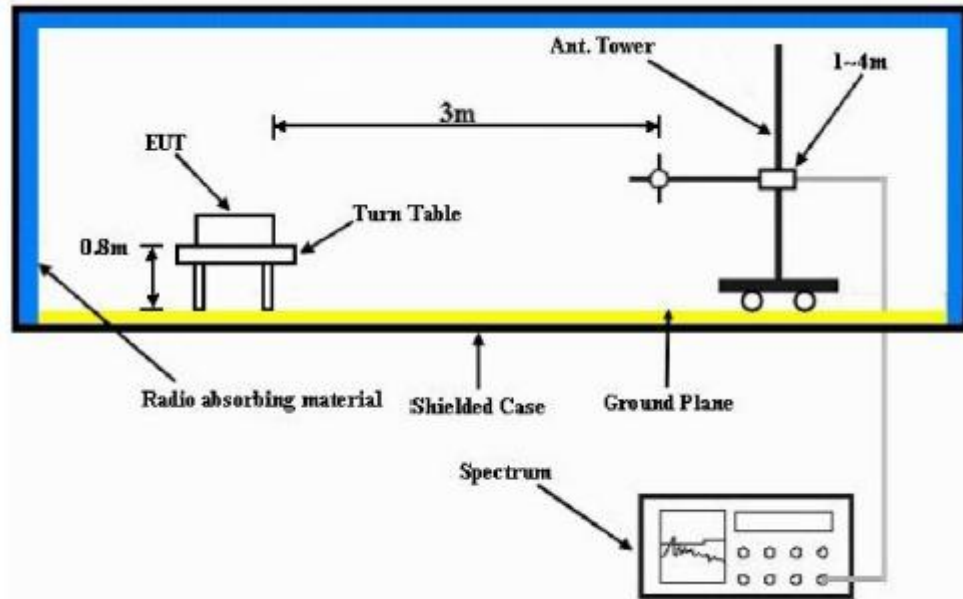

- 1) The Resolution Bandwidth for scanning Radiated Emission below 1 GHz is 100 kHz with Video Bandwidth = 300 kHz and Resolution Bandwidth for above 1 GHz is 1 MHz with Video Bandwidth = 3 MHz. Detector mode is positive peak.
- 2) In the semi- anechoic chamber, setup as illustrated above the DUT placed on the 0.8m height (for frequencies < 1GHz) or 1.5m (for frequencies > 1GHz) of Turn Table, rotated the table around 360 degrees to search the maximum radiation power and receiver antenna shall be rotated vertical and horizontal polarization and moved height from 1m to 4m to find the maximum polar radiated power. The “Read Value” is the spectrum reading the maximum power value.
- 3) The substitution antenna is substituted for DUT at the same position and signals generator (S.G) export the CW signal to the substitution antenna via a TX cable. The receiver antenna shall be rotated vertical and horizontal polarization and moved height from 1m to 4m to find the maximum radiation power. Record the power level of maximum radiation power from spectrum. So, the measured substitution value = Ref level of S.G + TX cables loss – Substituted Antenna Gain.
- 4) Final Radiated Spurious Emission = “Read Value” + Measured substitution value.

6.11.1. Test Result (Analog)

SAC Transmitter Radiated Emission:

Model Number: VX-80-G6-4 S/N: XX9H010022 SR:18451-EMC-00002
 Battery Part No: CZ089B002 Accy Part No: NA
 Test Mode: TX Analog
 400.012500 MHz 12.5 kHz 1.000 Watt(s) /Low Power

Frequency (MHz)	Limit	Horizontal Measured Emission Equiv Pwr Into Ideal Dipole (dBm)	Vertical Measured Emission Equiv Pwr Into ideal Dipole (dBm)
800.0250	-20.0000	-41.6300 *	-39.9200 *
1200.0375	-20.0000	-47.9000 *	-48.4300 *
1600.0500	-20.0000	-52.4000 *	-52.7300 *
2000.0625	-20.0000	-55.2617 **	-56.1623 **
2400.0750	-20.0000	-55.9999 **	-56.8850 **
2800.0875	-20.0000	-55.0400 **	-54.9679 **
3200.1000	-20.0000	-52.3848 **	-51.7271 **
3600.1125	-20.0000	-52.8161 **	-51.5558 **
4000.1250	-20.0000	-51.2131 **	-51.0178 **

RADIATED SPURIOUS EMISSIONS

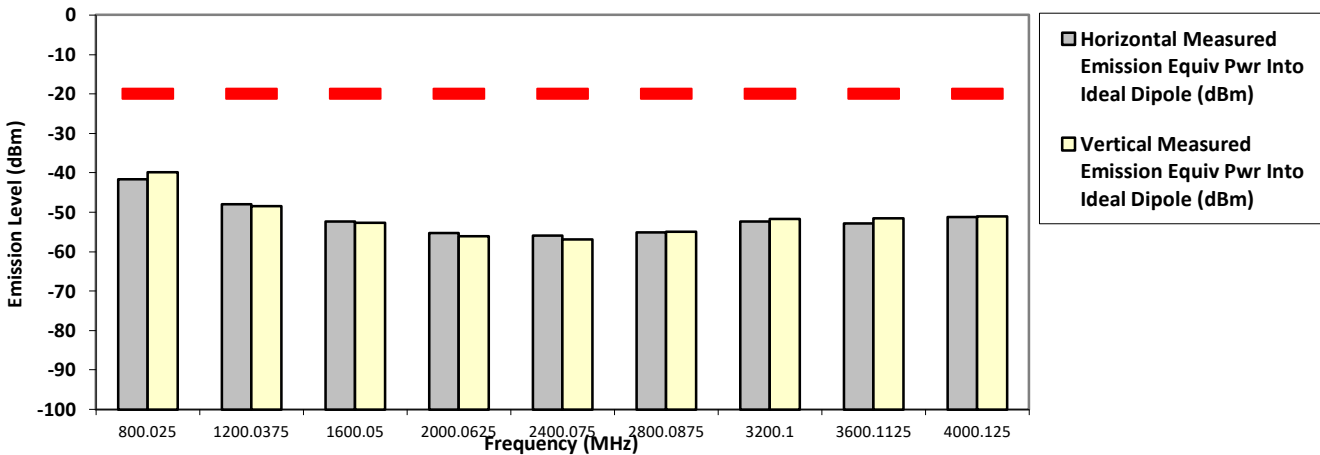

The data presented here was taken using the substitution method as found in the ANSI C63.26-2015 document.
 Motorola Penang EMC Lab - Test Performed by: Aiman, Azil & Faris Tue, Jul 09, 2019

Remarks: ** Indicates the spurious emission could not be detected due to noise limitations or ambient.

*Pursuant to CFR 47 Part 2.1057 (c), emissions attenuated more than 20 dB below the permissible limit are not reported
 Temp(Deg): 22.7 Hum(%RH): 70.0

System MU: 4.9 dB

Remarks:

Passed Results	Marginal Results	Failed Results
----------------	------------------	----------------

SAC Transmitter Radiated Emission:

Model Number: VX-80-G6-4 S/N: XX9H010022 SR:18451-EMC-00002
 Battery Part No: CZ089B002 Accy Part No: NA
 Test Mode: TX Analog
 400.012500 MHz 12.5 kHz 4.800 Watt(s) /Max Power

Frequency (MHz)	Limit	Horizontal Measured Emission Equiv Pwr Into Ideal Dipole (dBm)	Vertical Measured Emission Equiv Pwr Into ideal Dipole (dBm)
800.0250	-20.0000	-80.7699 **	-83.5162 **
1200.0375	-20.0000	-42.1900 *	-43.1300 *
1600.0500	-20.0000	-49.0700 *	-49.7000 *
2000.0625	-20.0000	-48.4800 *	-48.3300 *
2400.0750	-20.0000	-54.1968 **	-56.1413 **
2800.0875	-20.0000	-55.3791 **	-55.2316 **
3200.1000	-20.0000	-52.0705 **	-52.2296 **
3600.1125	-20.0000	-52.9172 **	-53.4515 **
4000.1250	-20.0000	-50.7352 **	-50.8541 **

RADIATED SPURIOUS EMISSIONS

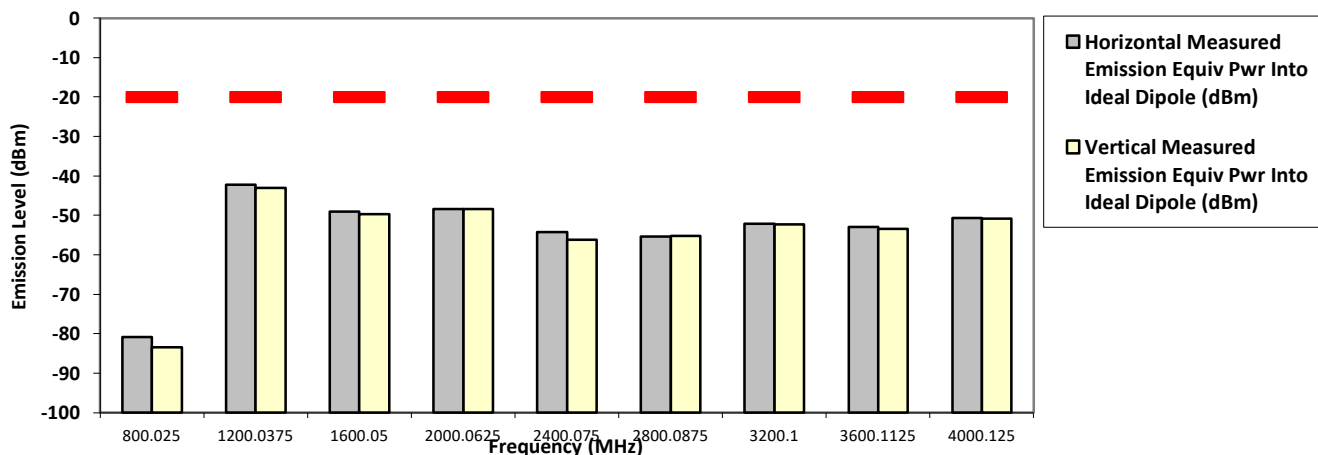

The data presented here was taken using the substitution method as found in the ANSI C63.26-2015 document.
 Motorola Penang EMC Lab - Test Performed by: Aiman, Azil & Faris Wed, Jul 10, 2019

Remarks: ** Indicates the spurious emission could not be detected due to noise limitations or ambient.
 *Pursuant to CFR 47 Part 2.1057 (c), emissions attenuated more than 20 dB below the permissible limit are not reported
 Temp(Deg): 22.7 Hum(%RH): 70.0

System MU: 4.9 dB

Remarks: Passed Results Marginal Results Failed Results

SAC Transmitter Radiated Emission:

Model Number: VX-80-G6-4 **S/N: XX9H010022** **SR:18451-EMC-00002**
Battery Part No: CZ089B002 **Accy Part No: NA**
400.012500 MHz **Test Mode: TX Analog** **1.000 Watt(s) /Low Power**
25 kHz

Frequency (MHz)	Limit	Horizontal Measured Emission Equip Pwr Into Ideal Dipole (dBm)	Vertical Measured Emission Equip Pwr Into ideal Dipole (dBm)
800.0250	-13.0000	-41.7500 *	-40.0900 *
1200.0375	-13.0000	-48.3300 *	-48.7100 *
1600.0500	-13.0000	-52.4100 *	-52.3700 *
2000.0625	-13.0000	-55.1108 **	-55.8278 **
2400.0750	-13.0000	-55.9524 **	-56.4721 **
2800.0875	-13.0000	-54.1215 **	-55.6478 **
3200.1000	-13.0000	-52.7544 **	-52.6479 **
3600.1125	-13.0000	-53.5455 **	-53.8589 **
4000.1250	-13.0000	-51.5214 **	-51.4186 **

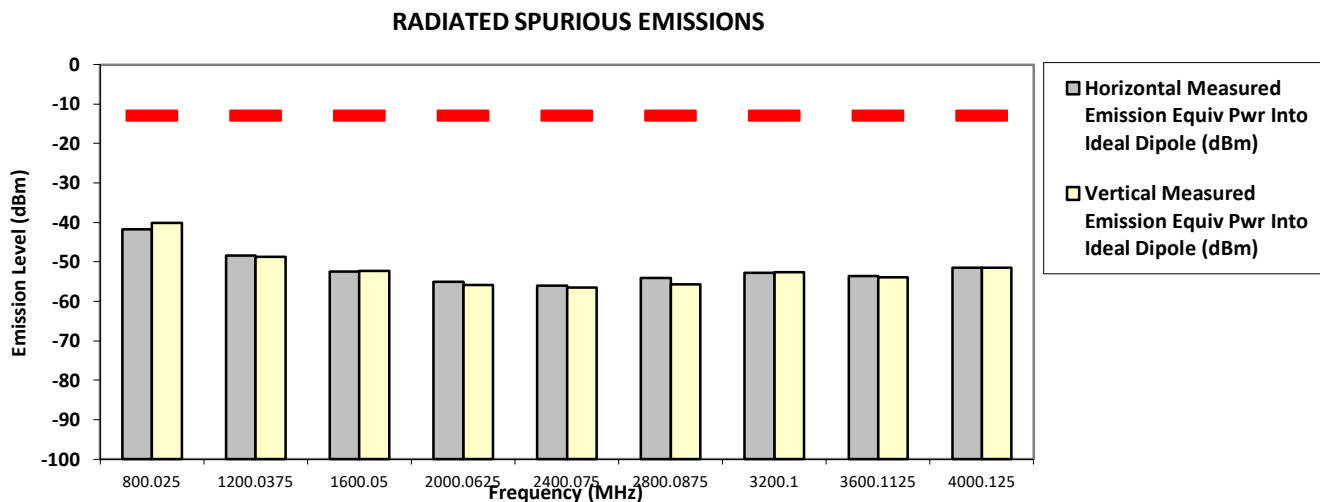

The data presented here was taken using the substitution method as found in the ANSI C63.26-2015 document.
 Motorola Penang EMC Lab - Test Performed by: Aiman, Azil & Faris Tue, Jul 09, 2019

Remarks: ** Indicates the spurious emission could not be detected due to noise limitations or ambient.
 *Pursuant to CFR 47 Part 2.1057 (c), emissions attenuated more than 20 dB below the permissible limit are not reported
 Temp(Deg): 22.7 Hum(%RH): 70.0

System MU: 4.9 dB

Remarks:	Passed Results	Marginal Results	Failed Results
-----------------	----------------	------------------	----------------

SAC Transmitter Radiated Emission:

Model Number: VX-80-G6-4 S/N: XX9H010022 SR:18451-EMC-00002
 Battery Part No: CZ089B002 Accy Part No: NA
 400.012500 MHz Test Mode: TX Analog 4.800 Watt(s) /Max Power
 25 kHz

Frequency (MHz)	Limit	Horizontal Measured Emission Equiv Pwr Into Ideal Dipole (dBm)	Vertical Measured Emission Equiv Pwr Into ideal Dipole (dBm)
800.0250	-13.0000	-44.8100 *	-43.5800 *
936.2980	-13.0000	-44.5900 *	-41.5600 *
1200.0375	-13.0000	-44.6900 *	-45.4800 *
1600.0500	-13.0000	-48.4800 *	-48.2600 *
2000.0375	-13.0000	-48.7500 *	-47.9100 *
2400.0750	-13.0000	-55.3335 **	-55.7297 **
2800.0875	-13.0000	-54.3367 **	-52.7358 **
3200.1000	-13.0000	-52.7482 **	-52.6631 **
3600.1125	-13.0000	-52.4504 **	-53.0677 **
4000.1250	-13.0000	-50.9147 **	-51.0814 **

RADIATED SPURIOUS EMISSIONS

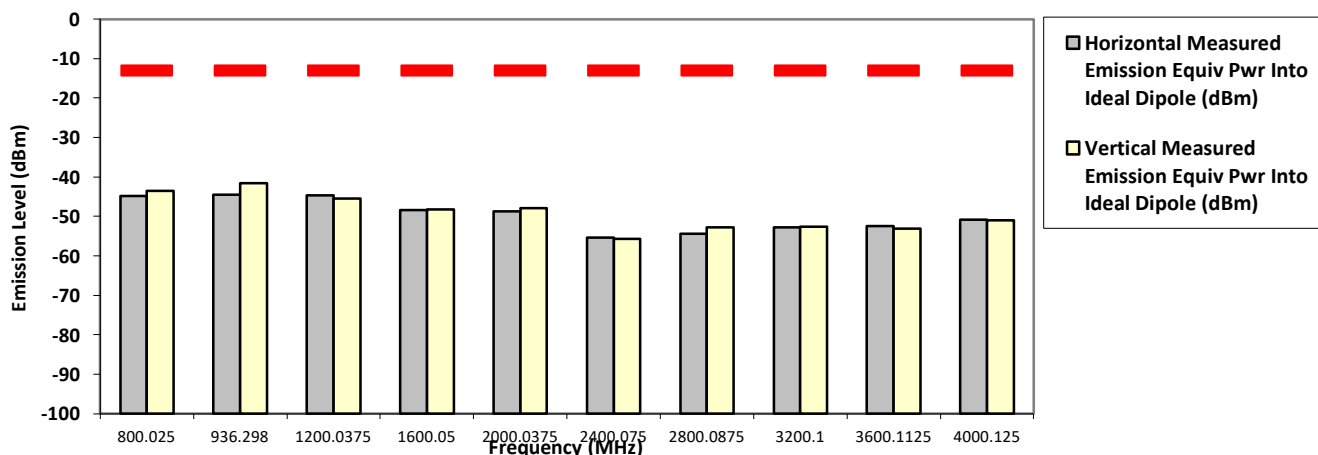

The data presented here was taken using the substitution method as found in the ANSI C63.26-2015 document.
 Motorola Penang EMC Lab - Test Performed by: Aiman, Azil & Faris Tue, Jul 09, 2019

Remarks: ** Indicates the spurious emission could not be detected due to noise limitations or ambient.
 *Pursuant to CFR 47 Part 2.1057 (c), emissions attenuated more than 20 dB below the permissible limit are not reported
 Temp(Deg): 22.7 Hum(%RH): 70.0

System MU: 4.9 dB

Remarks: Passed Results Marginal Results Failed Results

SAC Transmitter Radiated Emission:

Model Number: VX-80-G6-4 **S/N: XX9H010022** **SR:18451-EMC-00002**
Battery Part No: CZ089B002 **Test Mode: TX Analog** **Accy Part No: NA**
406.200000 MHz **12.5 kHz** **4.800 Watt(s) /Max Power**

Frequency (MHz)	Limit	Horizontal Measured Emission Equiv Pwr Into Ideal Dipole (dBm)	Vertical Measured Emission Equiv Pwr Into ideal Dipole (dBm)
812.4000	-20.0000	-83.4380 **	-84.6613 **
1218.6000	-20.0000	-44.4000 *	-45.1700 *
1624.8000	-20.0000	-47.1900 *	-47.6000 *
2031.0000	-20.0000	-49.1400 *	-48.0700 *
2437.2000	-20.0000	-53.8672 **	-56.2523 **
2843.4000	-20.0000	-52.8730 **	-53.3317 **
3249.6000	-20.0000	-53.4600 **	-52.3770 **
3655.8000	-20.0000	-54.2857 **	-53.8289 **
4062.0000	-20.0000	-51.2492 **	-51.6812 **

RADIATED SPURIOUS EMISSIONS

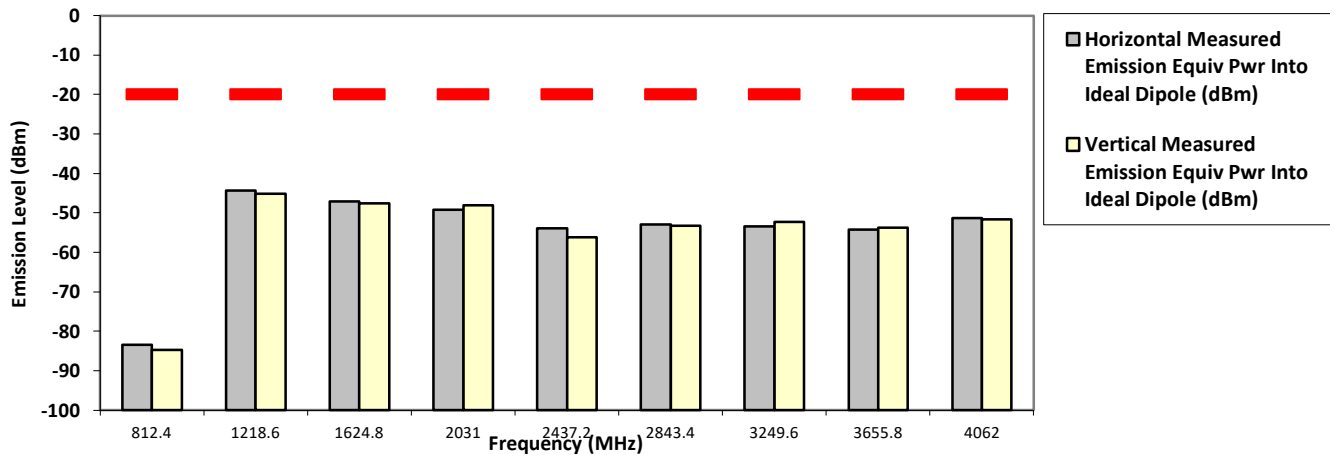

The data presented here was taken using the substitution method as found in the ANSI C63.26-2015 document.
 Motorola Penang EMC Lab - Test Performed by: Aiman, Azil & Faris Wed, Jul 10, 2019

Remarks: ** Indicates the spurious emission could not be detected due to noise limitations or ambient.
 *Pursuant to CFR 47 Part 2.1057 (c), emissions attenuated more than 20 dB below the permissible limit are not reported
 Temp(Deg): 22.7 Hum(%RH): 70.0

System MU: 4.9 dB

Remarks:

Passed Results	Marginal Results	Failed Results
----------------	------------------	----------------

SAC Transmitter Radiated Emission:

Model Number: VX-80-G6-4 **S/N: XX9H010022** **SR:18451-EMC-00002**
Battery Part No: CZ089B002 **Accy Part No: NA**
406.200000 MHz **Test Mode: TX Analog** **4.800 Watt(s) /Max Power**
25 kHz

Frequency (MHz)	Limit	Horizontal Measured Emission Equiv Pwr Into Ideal Dipole (dBm)	Vertical Measured Emission Equiv Pwr Into ideal Dipole (dBm)
812.4000	-13.0000	-82.3134 **	-83.9339 **
1218.6000	-13.0000	-45.0000 *	-46.3900 *
1624.8000	-13.0000	-46.7900 *	-46.9300 *
2031.0000	-13.0000	-49.8100 *	-48.4900 *
2437.2000	-13.0000	-49.5900 *	-48.6600 *
2843.4000	-13.0000	-53.7289 **	-53.2516 **
3249.6000	-13.0000	-52.5897 **	-52.2548 **
3655.8000	-13.0000	-53.0777 **	-53.3262 **
4062.0000	-13.0000	-51.2466 **	-50.2954 **

RADIATED SPURIOUS EMISSIONS

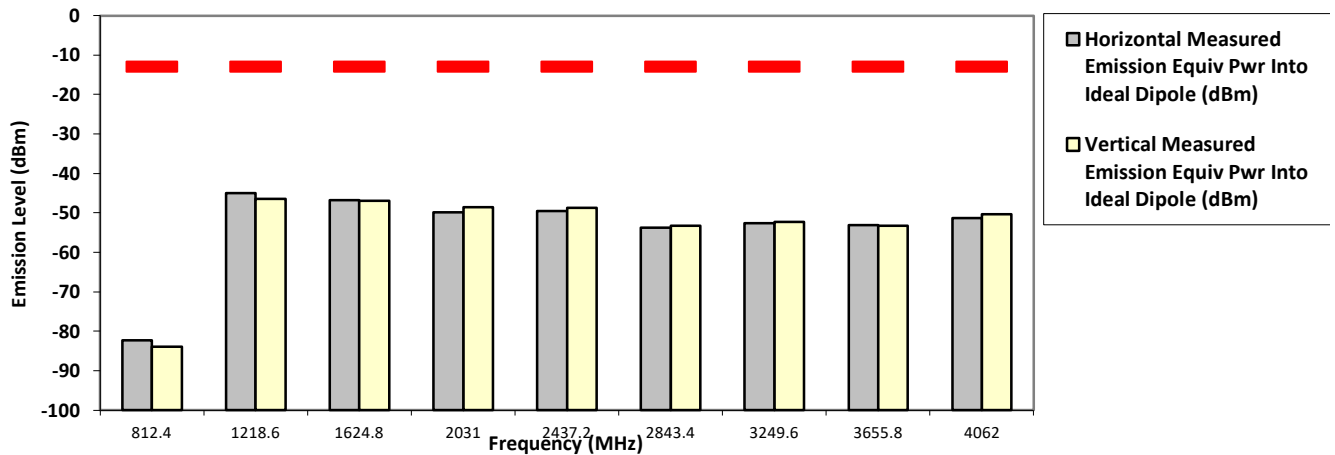

The data presented here was taken using the substitution method as found in the ANSI C63.26-2015 document.
 Motorola Penang EMC Lab - Test Performed by: Aiman, Azil & Faris Wed, Jul 10, 2019

Remarks: ** Indicates the spurious emission could not be detected due to noise limitations or ambient.
 *Pursuant to CFR 47 Part 2.1057 (c), emissions attenuated more than 20 dB below the permissible limit are not reported
 Temp(Deg): 22.7 Hum(%RH): 70.0

System MU: 4.9 dB

Remarks:

Passed Results	Marginal Results	Failed Results
----------------	------------------	----------------

SAC Transmitter Radiated Emission:

Model Number: VX-80-G6-4 **S/N: XX9H010022** **SR:18451-EMC-00002**
Battery Part No: CZ089B002 **Test Mode: TX Analog** **Accy Part No: NA**
450.025000 MHz **12.5 kHz** **1.000 Watt(s) /Low Power**

Frequency (MHz)	Limit	Horizontal Measured Emission Equiv Pwr Into Ideal Dipole (dBm)	Vertical Measured Emission Equiv Pwr Into ideal Dipole (dBm)
900.0500	-20.0000	-42.7300 *	-40.4400 *
1350.0750	-20.0000	-47.8000 *	-47.4600 *
1800.1000	-20.0000	-55.5974 **	-57.1783 **
2250.1250	-20.0000	-54.2852 **	-56.1126 **
2700.1500	-20.0000	-54.9192 **	-54.0933 **
3150.1750	-20.0000	-51.7317 **	-52.8357 **
3600.2000	-20.0000	-51.9146 **	-52.3780 **
4050.2250	-20.0000	-50.2930 **	-51.1967 **
4500.2500	-20.0000	-49.3847 **	-50.5561 **

RADIATED SPURIOUS EMISSIONS

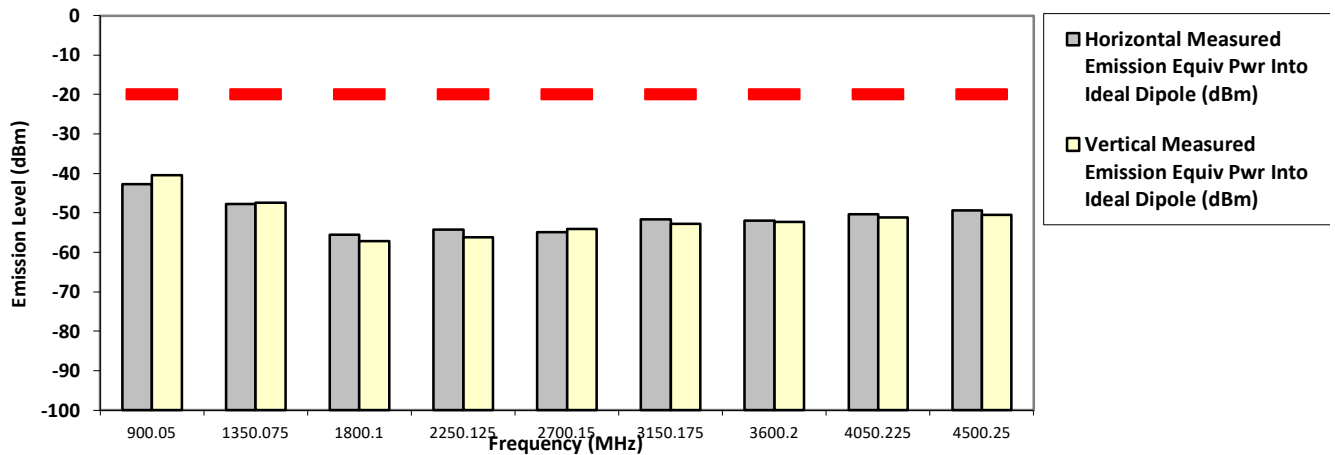

The data presented here was taken using the substitution method as found in the ANSI C63.26-2015 document.
 Motorola Penang EMC Lab - Test Performed by: Aiman, Azil & Faris Tue, Jul 09, 2019

Remarks: ** Indicates the spurious emission could not be detected due to noise limitations or ambient.
 *Pursuant to CFR 47 Part 2.1057 (c), emissions attenuated more than 20 dB below the permissible limit are not reported
 Temp(Deg): 22.7 Hum(%RH): 70.0

System MU: 4.9 dB

Remarks:

Passed Results	Marginal Results	Failed Results
----------------	------------------	----------------

SAC Transmitter Radiated Emission:

Model Number: VX-80-G6-4 **S/N: XX9H010022** **SR:18451-EMC-00002**
Battery Part No: CZ089B002 **Accy Part No: NA**
450.025000 MHz **Test Mode: TX Analog** **12.5 kHz** **4.800 Watt(s) /Max Power**

Frequency (MHz)	Limit	Horizontal Measured Emission Equiv Pwr Into Ideal Dipole (dBm)	Vertical Measured Emission Equiv Pwr Into ideal Dipole (dBm)
900.0500	-20.0000	-43.3400 *	-42.9500 *
1350.0750	-20.0000	-35.6300	-35.2500
1800.1000	-20.0000	-55.8600 **	-57.3847 **
2250.1250	-20.0000	-48.3200 *	-47.7800 *
2700.1500	-20.0000	-54.6677 **	-52.4825 **
3150.1750	-20.0000	-52.7956 **	-51.5884 **
3600.2000	-20.0000	-52.5700 **	-53.1222 **
4050.2250	-20.0000	-50.7265 **	-51.4959 **
4500.2500	-20.0000	-50.8055 **	-51.0947 **

RADIATED SPURIOUS EMISSIONS

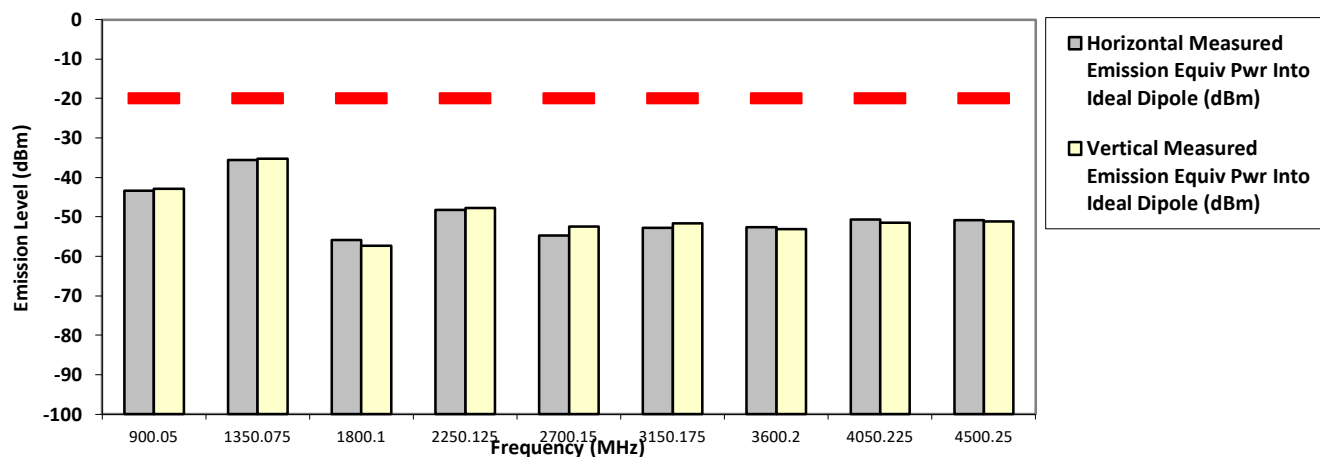

The data presented here was taken using the substitution method as found in the ANSI C63.26-2015 document.
 Motorola Penang EMC Lab - Test Performed by: Aiman, Azil & Faris Tue, Jul 09, 2019

Remarks: ** Indicates the spurious emission could not be detected due to noise limitations or ambient.
 *Pursuant to CFR 47 Part 2.1057 (c), emissions attenuated more than 20 dB below the permissible limit are not reported
 Temp(Deg): 22.7 Hum(%RH): 70.0

System MU: 4.9 dB

Remarks:

Passed Results	Marginal Results	Failed Results
----------------	------------------	----------------

SAC Transmitter Radiated Emission:

Model Number: VX-80-G6-4 **S/N: XX9H010022** **SR:18451-EMC-00002**
Battery Part No: CZ089B002 **Accy Part No: NA**
450.025000 MHz **Test Mode: TX Analog** **1.000 Watt(s) /Low Power**
25 kHz

Frequency (MHz)	Limit	Horizontal Measured Emission Equiv Pwr Into Ideal Dipole (dBm)	Vertical Measured Emission Equiv Pwr Into ideal Dipole (dBm)
900.0500	-13.0000	-42.7400 *	-43.1700 *
1350.0750	-13.0000	-49.2500 *	-50.9000 *
1800.1000	-13.0000	-55.5859 **	-55.7689 **
2250.1250	-13.0000	-55.7601 **	-56.1525 **
2700.1500	-13.0000	-54.5257 **	-55.2749 **
3150.1750	-13.0000	-51.5309 **	-52.3193 **
3600.2000	-13.0000	-53.4267 **	-52.5100 **
4050.2250	-13.0000	-51.0215 **	-47.8142 **
4500.2500	-13.0000	-50.1317 **	-50.0963 **

RADIATED SPURIOUS EMISSIONS

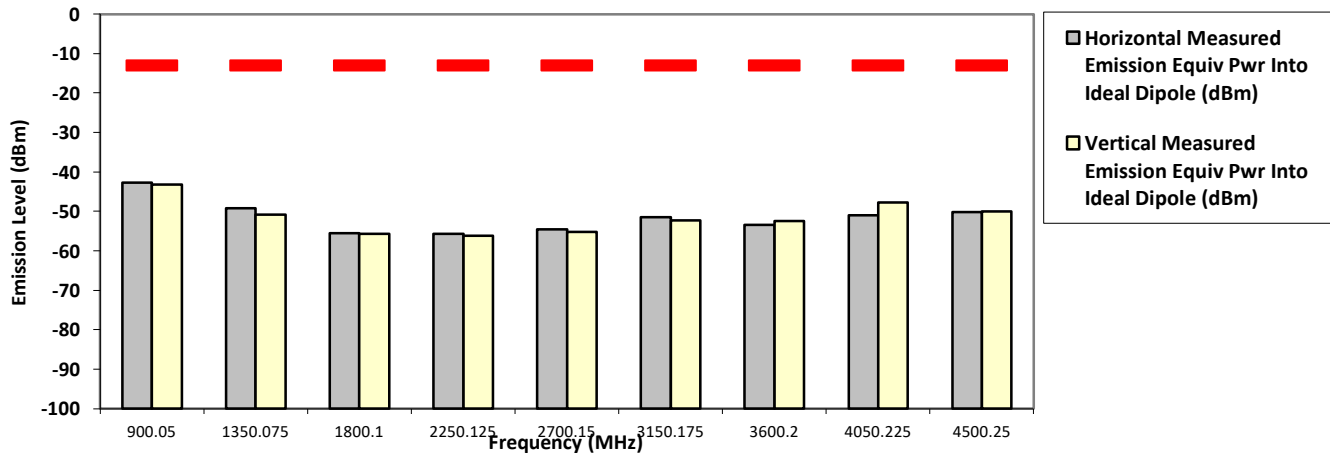

The data presented here was taken using the substitution method as found in the ANSI C63.26-2015 document.
 Motorola Penang EMC Lab - Test Performed by: Aiman, Azil & Faris Tue, Jul 09, 2019

Remarks: ** Indicates the spurious emission could not be detected due to noise limitations or ambient.
 *Pursuant to CFR 47 Part 2.1057 (c), emissions attenuated more than 20 dB below the permissible limit are not reported
 Temp(Deg): 22.7 Hum(%RH): 70.0

System MU: 4.9 dB

Remarks: Passed Results Marginal Results Failed Results

SAC Transmitter Radiated Emission:

Model Number: VX-80-G6-4

S/N: XX9H010022

SR:18451-EMC-00002

Battery Part No: CZ089B002

Accy Part No: NA

450.025000 MHz

Test Mode: TX Analog
 25 kHz

4.800 Watt(s) /Max Power

Frequency (MHz)	Limit	Horizontal Measured Emission Equiv Pwr Into Ideal Dipole (dBm)	Vertical Measured Emission Equiv Pwr Into ideal Dipole (dBm)
900.0500	-13.0000	-43.6000 *	-40.7700 *
1350.0750	-13.0000	-37.5700 *	-37.7000 *
1800.1000	-13.0000	-57.4569 **	-57.3368 **
2250.1250	-13.0000	-47.9100 *	-47.5300 *
2700.1500	-13.0000	-52.7245 **	-53.8824 **
3150.1750	-13.0000	-51.2423 **	-51.0110 **
3600.2000	-13.0000	-52.6974 **	-52.7218 **
4050.2250	-13.0000	-50.7920 **	-51.1993 **
4500.2500	-13.0000	-49.2676 **	-50.0996 **

RADIATED SPURIOUS EMISSIONS

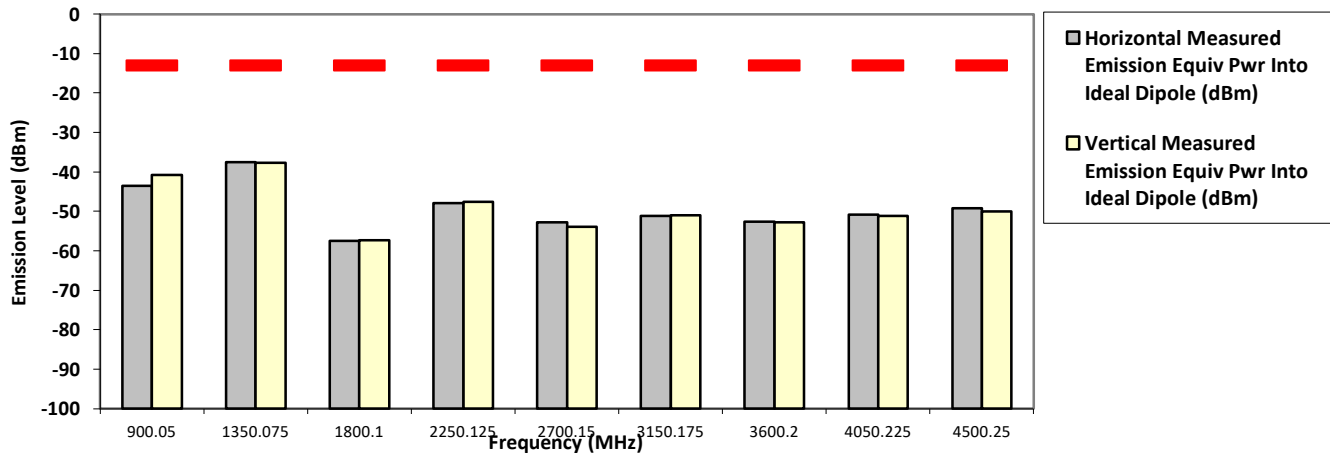

The data presented here was taken using the substitution method as found in the ANSI C63.26-2015 document.
 Motorola Penang EMC Lab - Test Performed by: Aiman, Azil & Faris Tue, Jul 09, 2019

Remarks: ** Indicates the spurious emission could not be detected due to noise limitations or ambient.
 *Pursuant to CFR 47 Part 2.1057 (c), emissions attenuated more than 20 dB below the permissible limit are not reported
 Temp(Deg): 22.7 Hum(%RH): 70.0

System MU: 4.9 dB

Remarks:

Passed Results	Marginal Results	Failed Results
----------------	------------------	----------------

SAC Transmitter Radiated Emission:

Model Number: VX-80-G6-4 S/N: XX9H010022 SR:18451-EMC-00002
 Battery Part No: CZ089B002 Accy Part No: NA
 Test Mode: TX Analog
 459.125000 MHz 12.5 kHz 4.800 Watt(s) /Max Power

Frequency (MHz)	Limit	Horizontal Measured Emission Equiv Pwr Into Ideal Dipole (dBm)	Vertical Measured Emission Equiv Pwr Into ideal Dipole (dBm)
918.2500	-20.0000	-42.2800 *	-39.1400
1377.3750	-20.0000	-41.5400 *	-41.8500 *
1836.5000	-20.0000	-53.6533 **	-55.2154 **
1893.5000	-20.0000	-54.2400 *	-53.9700 *
2295.6250	-20.0000	-47.8600 *	-46.7200 *
2754.7500	-20.0000	-54.1177 **	-53.6372 **
3213.8750	-20.0000	-50.8508 **	-51.4451 **
3673.0000	-20.0000	-52.1950 **	-53.2352 **
4132.1250	-20.0000	-50.8016 **	-50.5022 **
4591.2500	-20.0000	-49.9241 **	-50.9477 **

RADIATED SPURIOUS EMISSIONS

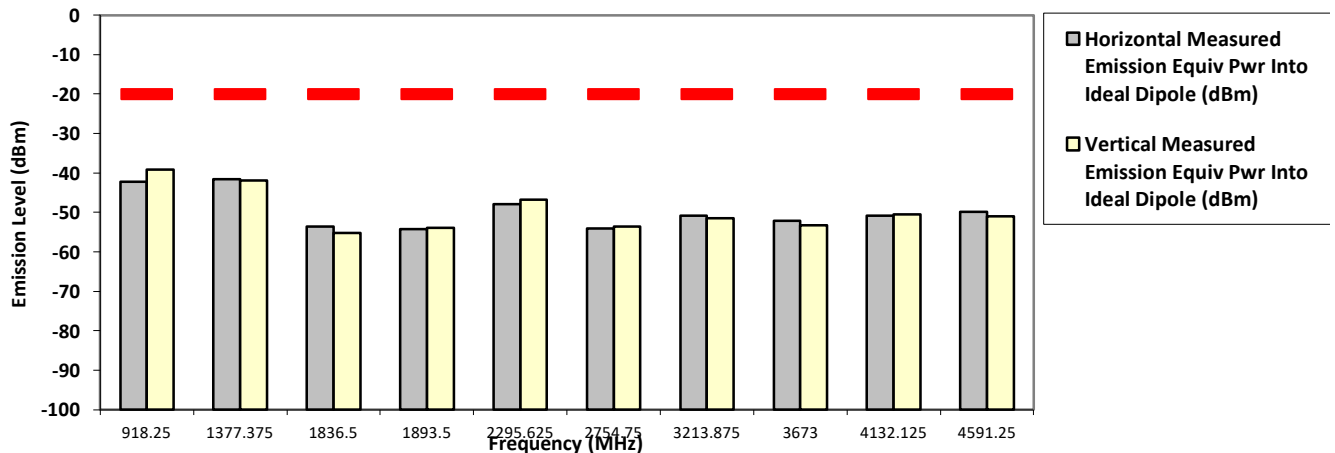

The data presented here was taken using the substitution method as found in the ANSI C63.26-2015 document.
 Motorola Penang EMC Lab - Test Performed by: Aiman, Azil & Faris Tue, Jul 09, 2019

Remarks: ** Indicates the spurious emission could not be detected due to noise limitations or ambient.
 *Pursuant to CFR 47 Part 2.1057 (c), emissions attenuated more than 20 dB below the permissible limit are not reported
 Temp(Deg): 22.7 Hum(%RH): 70.0

System MU: 4.9 dB

Remarks: Passed Results Marginal Results Failed Results

SAC Transmitter Radiated Emission:

Model Number: VX-80-G6-4 **S/N: XX9H010022** **SR:18451-EMC-00002**
Battery Part No: CZ089B002 **Accy Part No: NA**
459.125000 MHz **Test Mode: TX Analog** **4.800 Watt(s) /Max Power**
25 kHz

Frequency (MHz)	Limit	Horizontal Measured Emission Equiv Pwr Into Ideal Dipole (dBm)	Vertical Measured Emission Equiv Pwr Into ideal Dipole (dBm)
918.2500	-13.0000	-41.8300 *	-38.3300 *
1377.3750	-13.0000	-40.6200 *	-41.0100 *
1836.5000	-13.0000	-54.5170 **	-55.8358 **
1893.5000	-13.0000	-54.1100 *	-54.0100 *
2295.6250	-13.0000	-47.7000 *	-46.6400 *
2754.7500	-13.0000	-53.8865 **	-53.0563 **
3213.8750	-13.0000	-51.6793 **	-52.5483 **
3673.0000	-13.0000	-52.8978 **	-53.0144 **
4132.1250	-13.0000	-51.6596 **	-50.4635 **
4591.2500	-13.0000	-50.1737 **	-50.3865 **

RADIATED SPURIOUS EMISSIONS

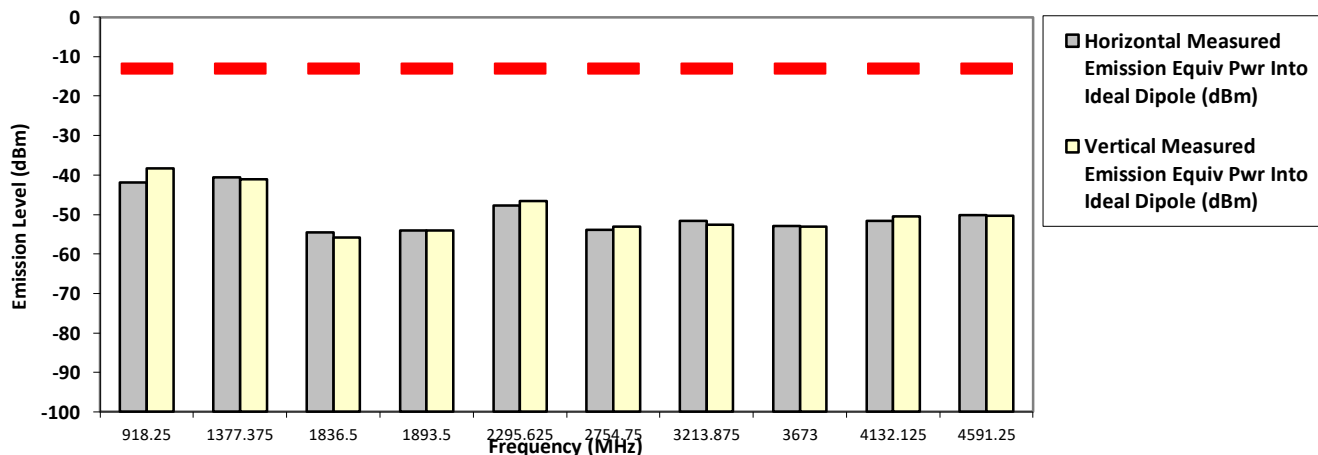

The data presented here was taken using the substitution method as found in the ANSI C63.26-2015 document.
 Motorola Penang EMC Lab - Test Performed by: Aiman, Azil & Faris Tue, Jul 09, 2019

Remarks: ** Indicates the spurious emission could not be detected due to noise limitations or ambient.
 *Pursuant to CFR 47 Part 2.1057 (c), emissions attenuated more than 20 dB below the permissible limit are not reported
 Temp(Deg): 22.7 Hum(%RH): 70.0

System MU: 4.9 dB

Remarks: Passed Results Marginal Results Failed Results

SAC Transmitter Radiated Emission:

Model Number: VX-80-G6-4 S/N: XX9H010022 SR:18451-EMC-00002
 Battery Part No: CZ089B002 Accy Part No: NA
 Test Mode: TX Analog
 467.775000 MHz 12.5 kHz 1.000 Watt(s) /Low Power

Frequency (MHz)	Limit	Horizontal Measured Emission Equiv Pwr Into Ideal Dipole (dBm)	Vertical Measured Emission Equiv Pwr Into ideal Dipole (dBm)
935.5500	-20.0000	-42.8800 *	-40.2700 *
1403.3250	-20.0000	-54.4300 *	-54.3000 *
1871.1000	-20.0000	-54.6025 **	-55.4847 **
2338.8750	-20.0000	-55.2936 **	-56.8930 **
2806.6500	-20.0000	-54.3569 **	-54.5994 **
3274.4250	-20.0000	-52.4609 **	-51.9187 **
3742.2000	-20.0000	-51.4520 **	-52.4133 **
4209.9750	-20.0000	-50.9814 **	-50.5210 **
4677.7500	-20.0000	-50.2753 **	-49.9499 **

RADIATED SPURIOUS EMISSIONS

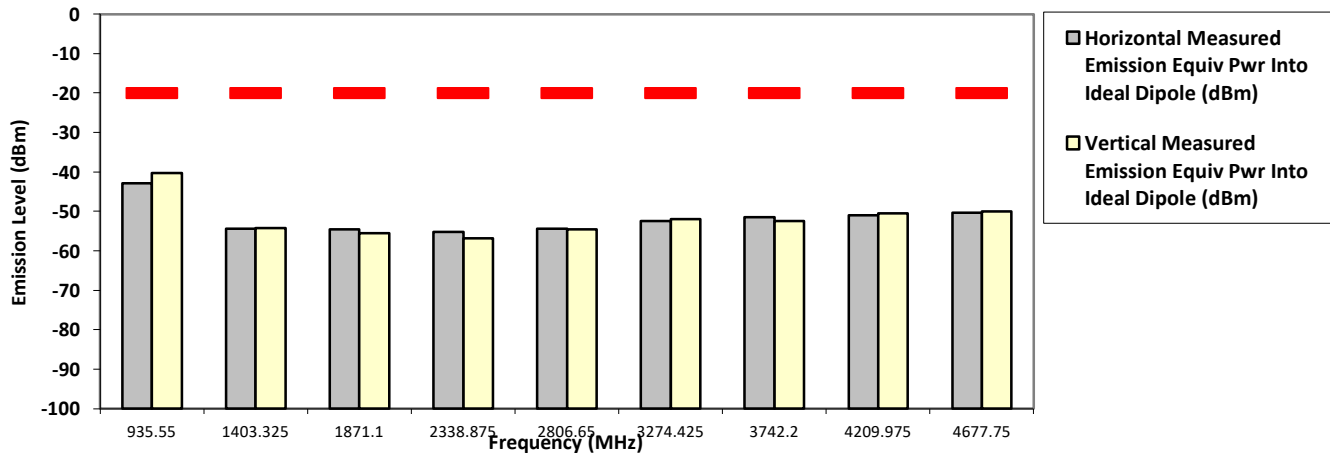

The data presented here was taken using the substitution method as found in the ANSI C63.26-2015 document.
 Motorola Penang EMC Lab - Test Performed by: Aiman, Azil & Faris Tue, Jul 09, 2019

Remarks: ** Indicates the spurious emission could not be detected due to noise limitations or ambient.
 *Pursuant to CFR 47 Part 2.1057 (c), emissions attenuated more than 20 dB below the permissible limit are not reported
 Temp(Deg): 22.7 Hum(%RH): 70.0

System MU: 4.9 dB

Remarks:

Passed Results	Marginal Results	Failed Results
----------------	------------------	----------------

SAC Transmitter Radiated Emission:

Model Number: VX-80-G6-4 S/N: XX9H010022 SR:18451-EMC-00002
 Battery Part No: CZ089B002 Accy Part No: NA
 Test Mode: TX Analog
 467.775000 MHz 12.5 kHz 4.800 Watt(s) /Max Power

Frequency (MHz)	Limit	Horizontal Measured Emission Equiv Pwr Into Ideal Dipole (dBm)	Vertical Measured Emission Equiv Pwr Into ideal Dipole (dBm)
935.5500	-20.0000	-42.3400 *	-40.2900 *
1403.3250	-20.0000	-45.7600 *	-45.7700 *
1871.1000	-20.0000	-57.2078 **	-58.0341 **
2338.8750	-20.0000	-52.9723 **	-55.5498 **
2806.6500	-20.0000	-55.7685 **	-54.7899 **
3274.4250	-20.0000	-52.2268 **	-50.4928 **
3742.2000	-20.0000	-51.5223 **	-52.0975 **
4209.9750	-20.0000	-49.7266 **	-50.2163 **
4677.7500	-20.0000	-48.7540 **	-49.6135 **

RADIATED SPURIOUS EMISSIONS

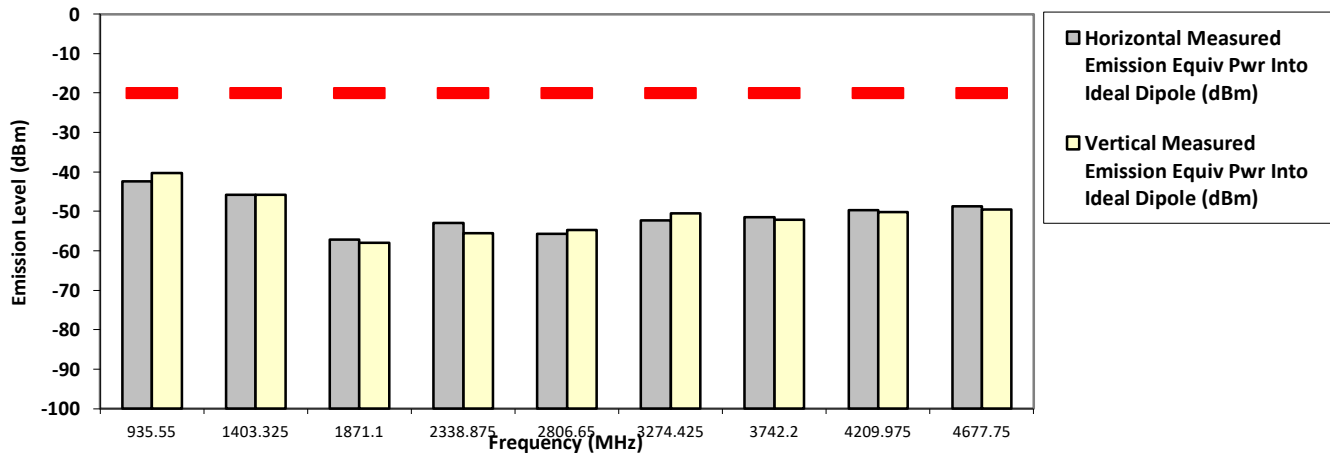

The data presented here was taken using the substitution method as found in the ANSI C63.26-2015 document.
 Motorola Penang EMC Lab - Test Performed by: Aiman, Azil & Faris Tue, Jul 09, 2019

Remarks: ** Indicates the spurious emission could not be detected due to noise limitations or ambient.
 *Pursuant to CFR 47 Part 2.1057 (c), emissions attenuated more than 20 dB below the permissible limit are not reported
 Temp(Deg): 22.7 Hum(%RH): 70.0

System MU: 4.9 dB

Remarks:

Passed Results	Marginal Results	Failed Results
----------------	------------------	----------------

SAC Transmitter Radiated Emission:

Model Number: VX-80-G6-4 **S/N: XX9H010022** **SR:18451-EMC-00002**
Battery Part No: CZ089B002 **Accy Part No: NA**
467.775000 MHz **Test Mode: TX Analog** **1.000 Watt(s) /Low Power**
25 kHz

Frequency (MHz)	Limit	Horizontal Measured Emission Equiv Pwr Into Ideal Dipole (dBm)	Vertical Measured Emission Equiv Pwr Into ideal Dipole (dBm)
935.5500	-13.0000	-80.4303 **	-81.8671 **
1403.3250	-13.0000	-53.7400 *	-53.3600 *
1871.1000	-13.0000	-54.7691 **	-55.2718 **
2338.8750	-13.0000	-56.6645 **	-56.8153 **
2806.6500	-13.0000	-55.6178 **	-55.2204 **
3274.4250	-13.0000	-52.8362 **	-52.8807 **
3742.2000	-13.0000	-50.7069 **	-52.4892 **
4209.9750	-13.0000	-50.9858 **	-49.5717 **
4677.7500	-13.0000	-50.0926 **	-49.4551 **

RADIATED SPURIOUS EMISSIONS

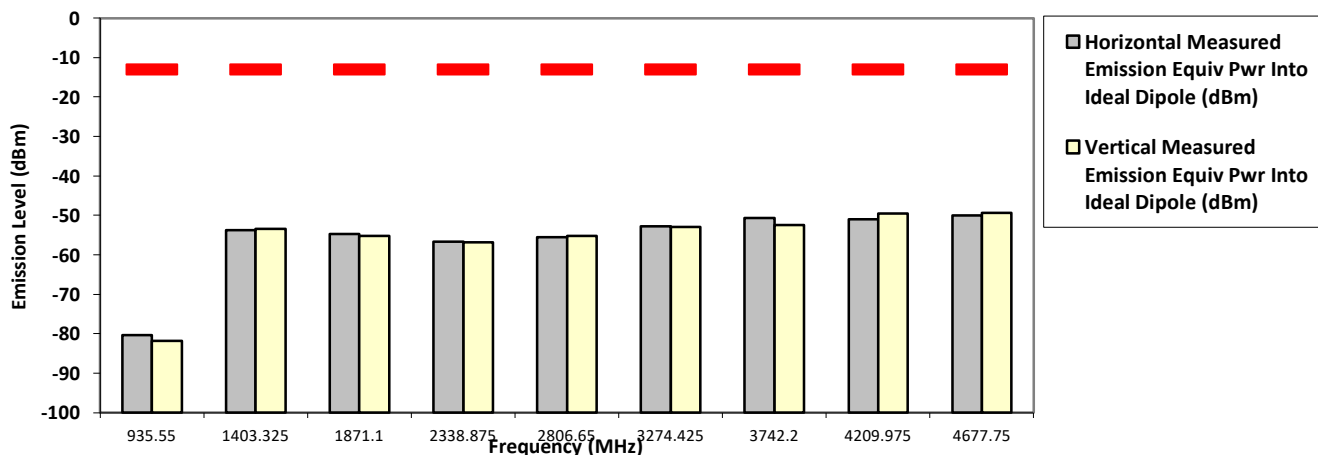

The data presented here was taken using the substitution method as found in the ANSI C63.26-2015 document.
 Motorola Penang EMC Lab - Test Performed by: Aiman, Azil & Faris Wed, Jul 10, 2019

Remarks: ** Indicates the spurious emission could not be detected due to noise limitations or ambient.
 *Pursuant to CFR 47 Part 2.1057 (c), emissions attenuated more than 20 dB below the permissible limit are not reported
 Temp(Deg): 22.7 Hum(%RH): 70.0

System MU: 4.9 dB

Remarks:

Passed Results	Marginal Results	Failed Results
----------------	------------------	----------------

SAC Transmitter Radiated Emission:

Model Number: VX-80-G6-4 S/N: XX9H010022 SR:18451-EMC-00002
 Battery Part No: CZ089B002 Accy Part No: NA
 467.775000 MHz Test Mode: TX Analog 25 kHz 4.800 Watt(s) /Max Power

Frequency (MHz)	Limit	Horizontal Measured Emission Equiv Pwr Into Ideal Dipole (dBm)	Vertical Measured Emission Equiv Pwr Into ideal Dipole (dBm)
935.5500	-13.0000	-42.1200 *	-39.4400 *
1403.3250	-13.0000	-47.4100 *	-46.6900 *
1871.1000	-13.0000	-57.4247 **	-55.9676 **
2338.8750	-13.0000	-53.4441 **	-55.8674 **
2806.6500	-13.0000	-55.8806 **	-53.6828 **
3274.4250	-13.0000	-51.7714 **	-51.3523 **
3742.2000	-13.0000	-51.2068 **	-52.5681 **
4209.9750	-13.0000	-51.3433 **	-50.4063 **
4677.7500	-13.0000	-47.9058 **	-49.7081 **

RADIATED SPURIOUS EMISSIONS

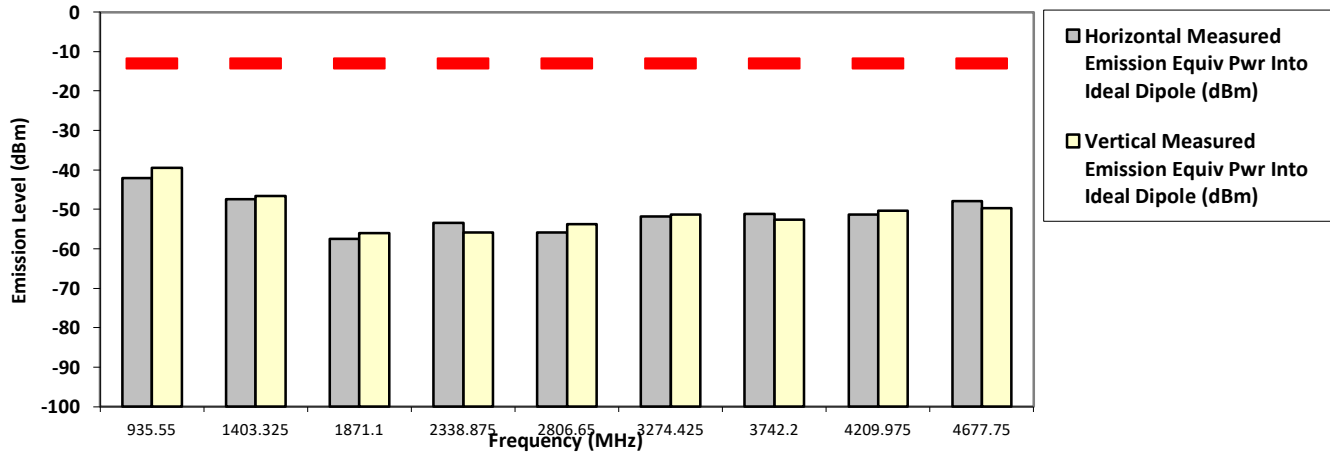

The data presented here was taken using the substitution method as found in the ANSI C63.26-2015 document.
 Motorola Penang EMC Lab - Test Performed by: Aiman, Azil & Faris Tue, Jul 09, 2019

Remarks: ** Indicates the spurious emission could not be detected due to noise limitations or ambient.

*Pursuant to CFR 47 Part 2.1057 (c), emissions attenuated more than 20 dB below the permissible limit are not reported
 Temp(Deg): 22.7 Hum(%RH): 70.0

System MU: 4.9 dB

Remarks:

Passed Results	Marginal Results	Failed Results
----------------	------------------	----------------

SAC Transmitter Radiated Emission:

Model Number: VX-80-G6-4 S/N: XX9H010022 SR:18451-EMC-00002
 Battery Part No: CZ089B002 Accy Part No: NA
 Test Mode: TX Analog
 469.987500 MHz 12.5 kHz 1.000 Watt(s) /Low Power

Frequency (MHz)	Limit	Horizontal Measured Emission Equiv Pwr Into Ideal Dipole (dBm)	Vertical Measured Emission Equiv Pwr Into ideal Dipole (dBm)
939.9750	-20.0000	-80.0545 **	-80.3957 **
1409.9625	-20.0000	-54.5900 *	-54.6200 *
1879.9500	-20.0000	-55.2783 **	-54.7205 **
2349.9375	-20.0000	-56.5599 **	-56.7425 **
2819.9250	-20.0000	-54.9785 **	-55.1858 **
3289.9125	-20.0000	-52.6770 **	-50.9247 **
3759.9000	-20.0000	-49.3874 **	-51.7282 **
4229.8875	-20.0000	-51.6201 **	-51.3782 **
4699.8750	-20.0000	-49.5506 **	-50.1101 **

RADIATED SPURIOUS EMISSIONS

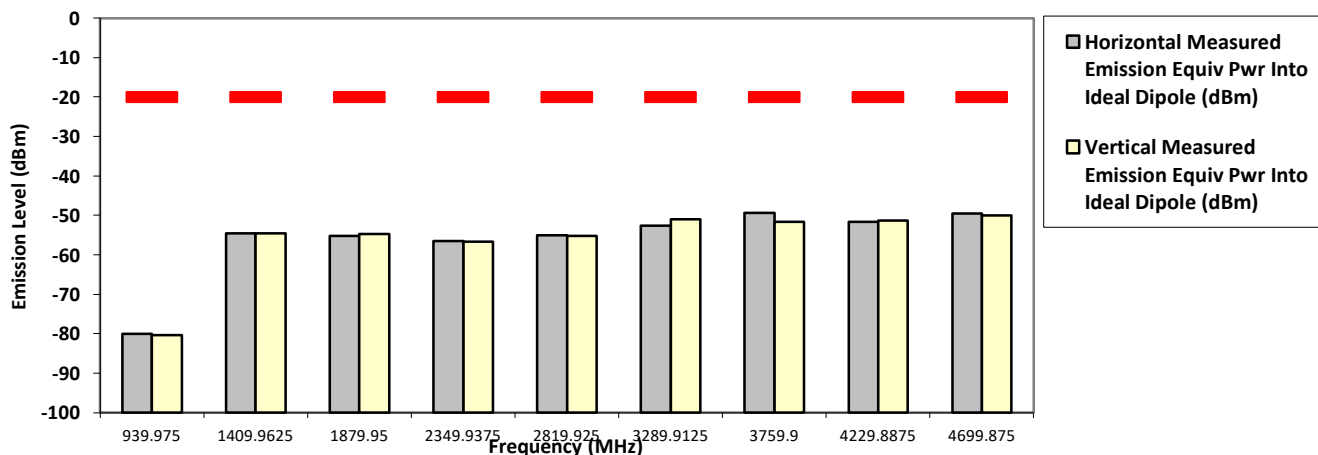

The data presented here was taken using the substitution method as found in the ANSI C63.26-2015 document.
 Motorola Penang EMC Lab - Test Performed by: Aiman, Azil & Faris Wed, Jul 10, 2019

Remarks: ** Indicates the spurious emission could not be detected due to noise limitations or ambient.
 *Pursuant to CFR 47 Part 2.1057 (c), emissions attenuated more than 20 dB below the permissible limit are not reported
 Temp(Deg): 22.7 Hum(%RH): 70.0

System MU: 4.9 dB

Remarks:

Passed Results	Marginal Results	Failed Results
----------------	------------------	----------------

SAC Transmitter Radiated Emission:

Model Number: VX-80-G6-4 S/N: XX9H010022 SR:18451-EMC-00002
 Battery Part No: CZ089B002 Accy Part No: NA
 Test Mode: TX Analog
 469.987500 MHz 12.5 kHz 4.800 Watt(s) /Max Power

Frequency (MHz)	Limit	Horizontal Measured Emission Equiv Pwr Into Ideal Dipole (dBm)	Vertical Measured Emission Equiv Pwr Into ideal Dipole (dBm)
939.9750	-20.0000	-41.6900 *	-40.4000 *
1409.9625	-20.0000	-43.7400 *	-43.7600 *
1879.9500	-20.0000	-54.0512 **	-54.6870 **
2349.9375	-20.0000	-55.4512 **	-53.9660 **
2819.9250	-20.0000	-54.4749 **	-52.5536 **
3289.9125	-20.0000	-51.4946 **	-50.3786 **
3759.9000	-20.0000	-50.4972 **	-51.2959 **
4229.8875	-20.0000	-49.8311 **	-51.0346 **
4699.8750	-20.0000	-48.0039 **	-49.7814 **

RADIATED SPURIOUS EMISSIONS

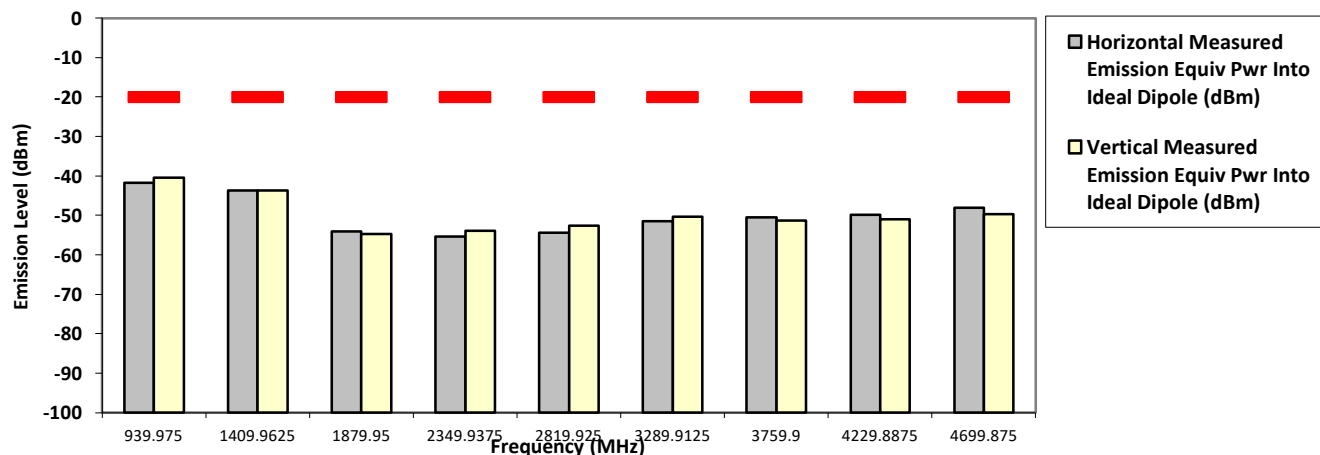

The data presented here was taken using the substitution method as found in the ANSI C63.26-2015 document.
 Motorola Penang EMC Lab - Test Performed by: Aiman, Azil & Faris Tue, Jul 09, 2019

Remarks: ** Indicates the spurious emission could not be detected due to noise limitations or ambient.
 *Pursuant to CFR 47 Part 2.1057 (c), emissions attenuated more than 20 dB below the permissible limit are not reported
 Temp(Deg): 22.7 Hum(%RH): 70.0

System MU: 4.9 dB

Remarks:

Passed Results	Marginal Results	Failed Results
----------------	------------------	----------------

SAC Transmitter Radiated Emission:
Model Number: VX-80-G6-4 **S/N: XX9H010022** **SR:18451-EMC-00002**
Battery Part No: CZ089B002 **Accy Part No: NA**
469.987500 MHz **Test Mode: TX Analog** **1.000 Watt(s) /Low Power**
25 kHz

Frequency (MHz)	Limit	Horizontal Measured Emission Equiv Pwr Into Ideal Dipole (dBm)	Vertical Measured Emission Equiv Pwr Into ideal Dipole (dBm)
939.9750	-13.0000	-79.4530 **	-81.6329 **
1409.9625	-13.0000	-54.2200 *	-54.3500 *
1879.9500	-13.0000	-51.6900 *	-51.8700 *
2349.9375	-13.0000	-54.2049 **	-56.5769 **
2819.9250	-13.0000	-55.3622 **	-55.0447 **
3289.9125	-13.0000	-52.6495 **	-52.0071 **
3759.9000	-13.0000	-51.4520 **	-51.8595 **
4229.8875	-13.0000	-49.7630 **	-50.4786 **
4699.8750	-13.0000	-49.4372 **	-48.2627 **

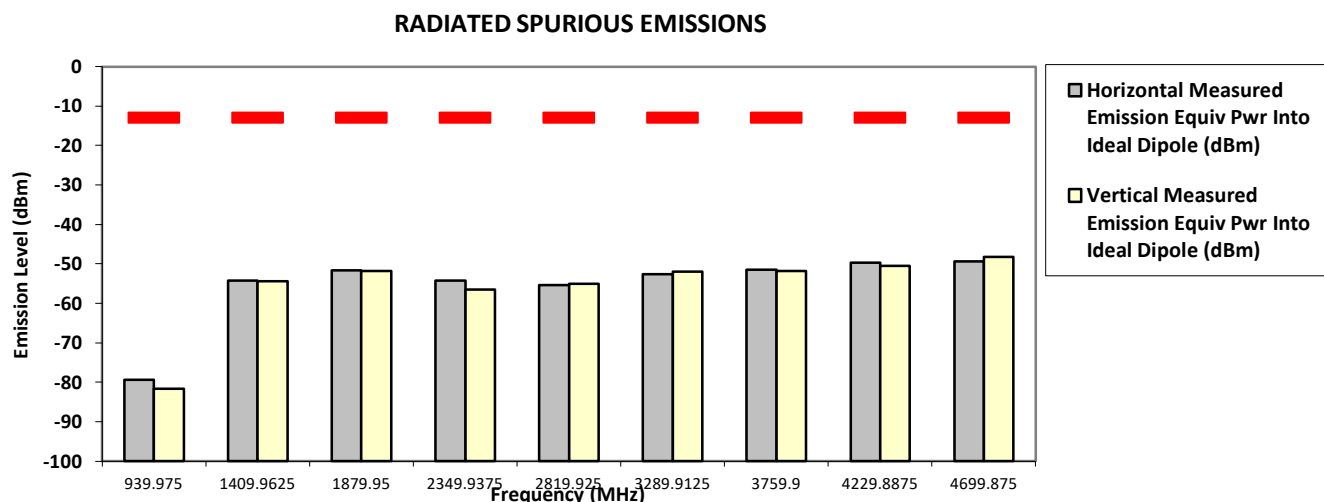

The data presented here was taken using the substitution method as found in the ANSI C63.26-2015 document.
 Motorola Penang EMC Lab - Test Performed by: Aiman, Azil & Faris Wed, Jul 10, 2019

Remarks: ** Indicates the spurious emission could not be detected due to noise limitations or ambient.
 *Pursuant to CFR 47 Part 2.1057 (c), emissions attenuated more than 20 dB below the permissible limit are not reported
 Temp(Deg): 22.7 Hum(%RH): 70.0

System MU: 4.9 dB

Remarks:

Passed Results	Marginal Results	Failed Results
----------------	------------------	----------------

SAC Transmitter Radiated Emission:

Model Number: VX-80-G6-4 S/N: XX9H010022 SR:18451-EMC-00002
 Battery Part No: CZ089B002 Accy Part No: NA
 469.987500 MHz Test Mode: TX Analog 4.800 Watt(s) /Max Power
 25 kHz

Frequency (MHz)	Limit	Horizontal Measured Emission Equiv Pwr Into Ideal Dipole (dBm)	Vertical Measured Emission Equiv Pwr Into ideal Dipole (dBm)
939.9750	-13.0000	-41.8500 *	-39.6500 *
1409.9625	-13.0000	-44.4000 *	-44.6300 *
1879.9500	-13.0000	-52.7900 *	-52.6200 *
2349.9375	-13.0000	-54.2695 **	-55.2087 **
2819.9250	-13.0000	-54.3394 **	-53.7463 **
3289.9125	-13.0000	-51.2259 **	-50.4174 **
3759.9000	-13.0000	-50.2256 **	-51.7889 **
4229.8875	-13.0000	-49.2698 **	-50.3438 **
4699.8750	-13.0000	-47.8674 **	-49.7493 **

RADIATED SPURIOUS EMISSIONS

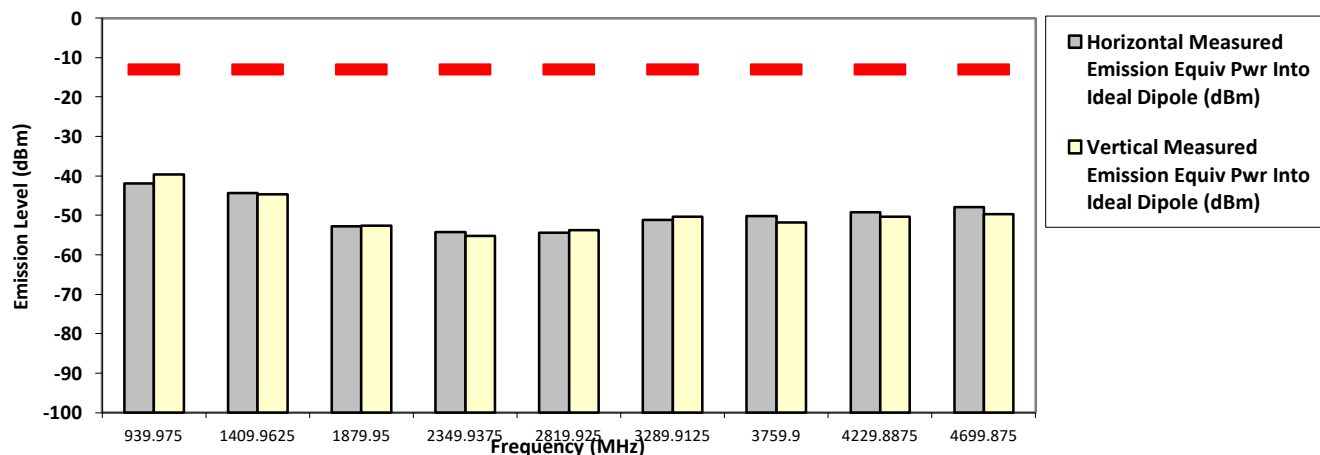

The data presented here was taken using the substitution method as found in the ANSI C63.26-2015 document.
 Motorola Penang EMC Lab - Test Performed by: Aiman, Azil & Faris Tue, Jul 09, 2019

Remarks: ** Indicates the spurious emission could not be detected due to noise limitations or ambient.
 *Pursuant to CFR 47 Part 2.1057 (c), emissions attenuated more than 20 dB below the permissible limit are not reported
 Temp(Deg): 22.7 Hum(%RH): 70.0

System MU: 4.9 dB

Remarks:

Passed Results	Marginal Results	Failed Results
----------------	------------------	----------------

6.11.2. Test Limit

Table below summarized the power of any emission outside a licensee's frequency block shall be attenuated below the transmitter power (P) by at least

Channel Spacing	Part 22	Part 24D	Part 74	Part 80	Part 90 (UHF, VHF, 800, 900)	Part 90 (700)
12.5kHz	43 + log ₁₀ (P) (-13 dBm)	43 + log ₁₀ (P) (-13 dBm)	43 + log ₁₀ (P) (-13 dBm)	Not Applicable	50 + log ₁₀ (P) (-20 dBm)	43 + log ₁₀ (P) (-13 dBm)
25kHz		Not Applicable		43 + log ₁₀ (P) (-13 dBm)	43 + log ₁₀ (P) (-13 dBm)	43 + log ₁₀ (P) (-13 dBm)

Channel Spacing	RSS 134	RSS 182	RSS 119 (UHF, VHF, 800, 900)	RSS 119 (700)
12.5kHz	43 + log ₁₀ (P) (-13 dBm)	Not Applicable	50 + log ₁₀ (P) (-20 dBm)	43 + log ₁₀ (P) (-13 dBm)
25kHz	Not Applicable	43 + log ₁₀ (P) (-13 dBm)	43 + log ₁₀ (P) (-13 dBm)	43 + log ₁₀ (P) (-13 dBm)

6.12. Effective Radiated Power (ERP)

6.12.1. Test Setup

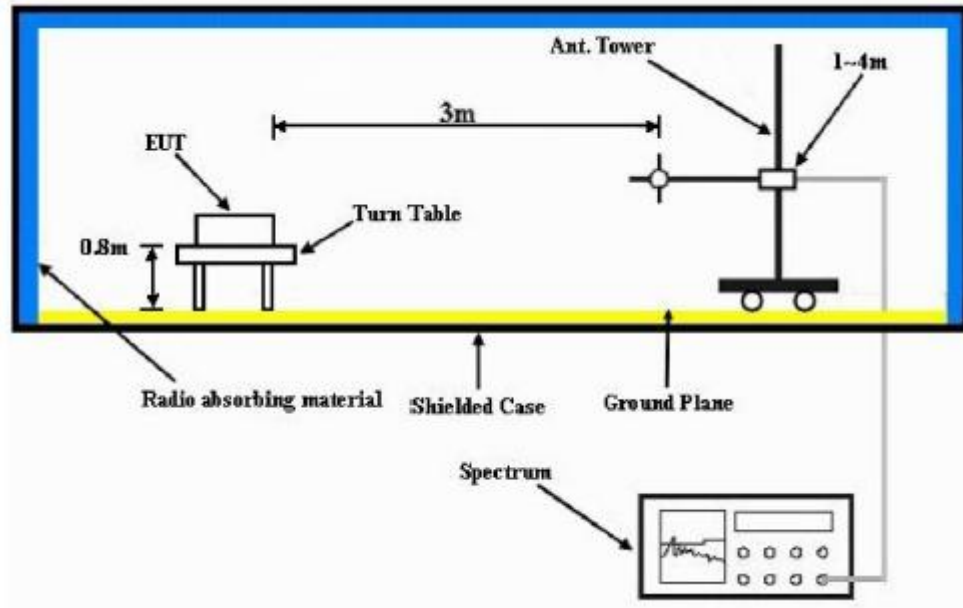

- 1) The Resolution Bandwidth for Equivalent Radiated Power (ERP) below 1 GHz is 100 kHz with Video Bandwidth = 300 kHz and Resolution Bandwidth for EIRP above 1 GHz is 1 MHz with Video Bandwidth = 3 MHz. Detector Mode is RMS.
- 2) In the semi-anechoic chamber, setup as illustrated above the DUT placed on the 0.8m height of Turn Table, rotated the table 45 degree each interval to search the maximum radiation power and receiver antenna shall be rotated vertical and horizontal polarization and moved height from 1m to 4m to find the maximum polar radiated power for each degree interval. The “Read Value” is the spectrum reading of maximum power value.
- 3) The substitution antenna is substituted for DUT at the same position and signals generator (S.G) export the CW signal to the substitution antenna via a TX cable. The receiver antenna shall be rotated vertical and horizontal polarization and moved height from 1m to 4m to find the maximum radiation power. Record the power level of maximum radiation power from spectrum. So, the Measured substitution value = Ref level of S.G + TX cables loss – Substituted Antenna Gain.

6.12.2. Test Result

NA → Not Applicable

6.12.3. Test Limit

The maximum output power of the transmitter for mobile stations is 100 watts (20 dB). Power is given in terms of effective radiated power (ERP).

6.13. GNSS (EIRP for 1559 - 1610MHz)

6.13.1. Test Setup

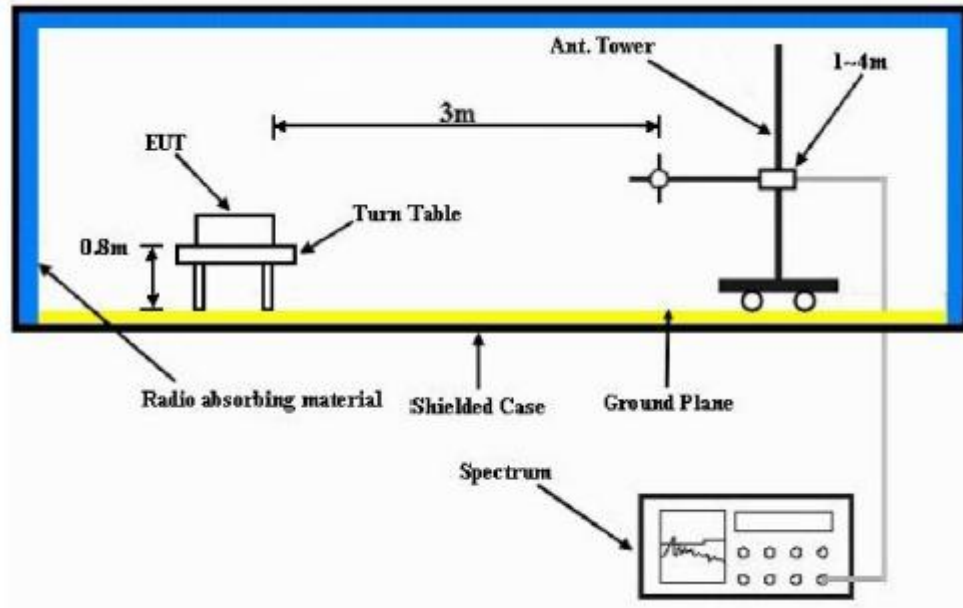

- 4) The Resolution Bandwidth for Equivalent Isotropically Radiated Power (EIRP) below 1 GHz is 100 kHz with Video Bandwidth = 300 kHz and Resolution Bandwidth for EIRP above 1 GHz is 1 MHz with Video Bandwidth = 3 MHz. Detector Mode is RMS.
- 5) In the semi-anechoic chamber, setup as illustrated above the DUT placed on the 0.8m height of Turn Table, rotated the table 45 degree each interval to search the maximum radiation power and receiver antenna shall be rotated vertical and horizontal polarization and moved height from 1m to 4m to find the maximum polar radiated power for each degree interval. The “Read Value” is the spectrum reading of maximum power value.
- 6) The substitution antenna is substituted for DUT at the same position and signals generator (S.G) export the CW signal to the substitution antenna via a TX cable. The receiver antenna shall be rotated vertical and horizontal polarization and moved height from 1m to 4m to find the maximum radiation power. Record the power level of maximum radiation power from spectrum. So, the Measured substitution value = Ref level of S.G + TX cables loss – Substituted Antenna Gain.
- 7) $EIRP = \text{“Read Value”} + \text{Measured substitution value} + 2.15$.

6.13.1. Test Result

NA → Not Applicable

6.13.2. Test Limit

For operations in the 758-775 MHz and 788-805 MHz bands, all emissions including harmonics in the band 1559-1610 MHz shall be limited to -70 dBW/MHz equivalent isotropically radiated power (EIRP) for wideband signals, and -80 dBW EIRP for discrete emissions of less than 700 Hz bandwidth.

~ End of Report ~