

Exhibit 6: Test Report

TEST REPORT FROM:

COMMUNICATION CERTIFICATION LABORATORY
1940 W. Alexander Street
Salt Lake City, Utah
84119-2039

Type of Report: Certification

TEST OF: PS3D

FCC ID: AY5PS3D

To Part 15 Subpart D
of the FCC Rules and Regulations

Test Report Serial No: 73-7889

Applicant:

NEC AMERICA, INC.
6535 North State Hwy 161
Irving, TX 75039-2402

Date(s) of Test: July 7 - 10, 2003

Issue Date: July 16, 2003

Equipment Receipt Date: July 7, 2003

CERTIFICATION OF ENGINEERING REPORT

This report has been prepared by Communication Certification Laboratory to evaluate the device described below with the requirements of FCC Part 15, Subpart D. Specific identifying information for the device tested is given below.

- Applicant NEC AMERICA, INC.
 6535 North State Hwy 161
 Irving, TX 75039-2402
- Manufacturer: NEC Corporation
 7-1 5 Chome Shiba
 Minato-Ku
 Tokyo, 108-01 Japan
- Trade Name: NEC
- Model Number: PS3D
- FCC ID Number: AY5PS3D

On this 16th day of July 2003, I, individually, and for Communication Certification Laboratory, certify that the statements made in this engineering report are true, complete, and correct to the best of my knowledge, and are made in good faith.

COMMUNICATION CERTIFICATION LABORATORY



Tested by: Jeffrey L. Draney
EMC Technician

SECTION 1 GENERAL INFORMATION

1.1 Product Description

The PS3D is the handset (PS) portion of a wireless PBX system. The system consists of a PBX, Wireless Communication system (WCS) (installed inside of the PBX), ZT and handset (PS). The ZT's are installed throughout the coverage area and hard wired to the base station controller. The user carries a wireless PS which allows the user access to the PBX functions from any location within the coverage area.

This application is for the PS which is identified by FCC ID: AY5PS3D. The ZT portion of the system is unchanged from the original certification identified by FCC ID: AY5SN933WEK. The ZT (MN:SN933 WEK-A) performs all of the channel monitoring and selection functions. The ZT was not changed, and all of the test data on the ZT was taken from the original certification report.

This PS is functional the same as a previously certified PS (FCC ID: AY5SN531PSTH); therefore, it can be installed with the previously certified PS's and will also work with the previously certified ZT's (FCC ID: AY5SN933WEK).

1.2 Test Specification

The PS3D is an Isochronous device that operates in the 1920-1930 MHz sub-band; therefore the PS3D is subject to the provisions of FCC Part 15, Subpart D. Unlicensed Personal Communications Service Devices.

1.3 Test Methods & Procedures

The PS3D was tested in accordance with ANSI C63.17-1998.

SECTION 2. SUMMARY OF TEST RESULTS:**2.1 Summary of Tests:**

FCC Section	Description	Report Section	ANSI C63.17 Section	Result
15.307	Affidavit from UTAM, Inc. certifying participation in UTAM, Inc.	3.2.1	N/A	Complies
15.309	Cross Reference to Subpart B	3.2.2	6.1.6.3	Complies
15.311	Labelling Requirements	3.2.3	N/A	Complies
15.315	AC power line conducted limits	3.2.4	N/A	Complies
15.317	Antenna requirement	3.2.5	N/A	Complies
15.319 (a)	Frequency of operation	3.2.6	N/A	Complies
15.319 (b)	Modulation technique	3.2.7	6.1.4	Complies
15.319 (c)	Peak transmit power and emission bandwidth	3.2.8	6.1.2	Complies
15.319 (d)	Power spectral density	3.2.9	6.1.5	Complies
15.319 (e)	Directional gain of antenna	3.2.10	N/A	Complies
15.319 (f)	Automatic discontinuance of transmission	3.2.11	N/A	Complies
15.319 (i)	IEEE C95.1-1991 and IEEE C95.3-1991	3.2.12	N/A	Complies
15.323 (a)	Channel allocation	3.2.13	N/A	Complies
15.323 (b)	Channel packing	3.2.14	8.1.2	Complies

FCC Section	Description	Report Section	ANSI C63.17 Section	Result
15.232 (c)	Time and Spectrum monitoring	3.2.15	Sections 7 and 8	Complies
15.323 (c) (1)	Transmit window monitoring	3.2.16	7.3.2.2 7.5	Complies
15.323 (c) (2)	Monitoring threshold	3.2.17	7.3.2.1	Complies
15.323 (c) (3)	Transmission duration	3.2.18	N/A	Complies
15.323 (c) (4)	Acknowledgments	3.2.19	8.2.1 8.1.3	Complies
15.323 (c) (5)	Least interfered channel	3.2.20	7.3.2.1, 7.3.2.2 8.2.1	Complies
15.323 (c) (6)	Random waiting interval	3.2.21	8.1.3 8.2.1	Complies
15.323 (c) (7)	Threshold monitoring bandwidth, Threshold monitoring reaction time	3.2.22	7.4 7.5	Complies
15.323 (c) (8)	Threshold monitoring antenna	3.2.23	N/A	Complies
15.323 (c) (9)	Monitoring threshold relaxation	3.2.24	N/A	Complies
15.323 (c) (10)	Duplex connections	3.2.25	8.2.3	Complies
15.323 (c) (11)	Alternative monitoring interval	3.2.26	8.2.4	Complies
15.323 (c) (12)	Limitation on use of Section (c) (10) or (c) (11)	3.2.27	N/A	Complies
15.323 (d)	Spurious emissions	3.2.28	6.1.6	Complies

FCC Section	Description	Report Section	ANSI C63.17 Section	Result
15.323 (e)	Frame repetition stability / frame period and jitter	3.2.29	6.2.3 6.2.4	Complies
15.323 (f)	Frequency stability	3.2.30	6.2.2	Complies

SECTION 3. MEASUREMENTS, EXAMINATIONS AND DERIVED RESULTS:**3.1 General Comments**

This section contains the test results only. Details of the test methods used, etc., can be found in Appendix A of this report.

3.2 Test Results**3.2.1 Coordination with fixed microwave service § 15.307****Measurement Data:**

The affidavit from UTAM, Inc. is enclosed in Exhibit 12.

3.2.2 Cross Reference to Subpart B § 15.309

The requirements of Subpart D apply only to the radio transmitter contained in the PCS device. Other aspects of the operation of a PCS device may be subject to requirements contained elsewhere in this Chapter. In particular, a PCS device that includes digital circuitry not directly associated with the radio transmitter also is subject to the requirements for unintentional radiators in Subpart B. The PS3D tunes up to 1930 MHz; therefore, in accordance with § 15.33 (b) (1), the EUT was tested from 30 MHz to 10 GHz.

The PS3D complies with the limits shown below for a class B unintentional radiator:

§ 15.109 Radiated Emission Limits Class A

Frequency (MHz)	Field Strength at 10 m ($\mu\text{V}/\text{m}$)	Field Strength at 3 m ($\text{dB}\mu\text{V}/\text{m}$)
30 - 88	90	49.1
88 - 216	150	53.5
216 - 960	210	56.4
960 - 10,000	300	59.5

§ 15.109 Radiated Emission Limits Class B

Frequency of emission (MHz)	Field Strength at 3 m (dB μ V/m)
30 - 88	40.0
88 - 216	43.5
216 - 960	46.0
Above 960	54.0

Measurement Data:

The radiated spurious emissions were tested with the PS3D in the receive mode. The PS3D complied with the class B limits, shown below is the data showing compliance to class B.

Frequency MHz	Polarity H/V, Detection	Uncorr Level dB μ V	Correction Factor dB	Corrected Level dB μ V/m	Criteria dB μ V/m
4865.0	V Peak	21.4	35.1	56.5	74.0
4865.0	V Average	17.8	35.1	52.9	54.0
3356.0	H Peak	16.3	32.1	48.4	74.0
3356.0	H Average	0.7	32.1	32.8	54.0
4865.0	H Peak	17.6	35.1	52.7	74.0
4865.0	H Average	13.6	35.1	48.7	54.0
Note 1: There were no emissions detected below 1000 MHz.					

EUT Configuration

The PS3D was placed in the idle mode and placed on the table.

A diagram of the test configuration is enclosed in Appendix A and a list of reference codes for test equipment used is enclosed in Appendix B.

Test equipment used: 1, 2, 3, 4, and 5.

Sample Calculation

The field strength is calculated by adding the Antenna Factor and Cable Factor, and subtracting the Amplifier Gain (if any) from the measured reading. The basic equation with a sample calculation is as follows:

$$FS = RA + AF + CF - AG$$

where FS = Field Strength
 RA = Receiver Amplitude
 AF = Antenna Factor
 CF = Cable Attenuation Factor
 AG = Amplifier Gain

Assume a receiver reading of 52.5 dB μ V is obtained. The correction factor of -8.9 dB is added to the receiver reading giving field strength of 32 dB μ V/m.

The correction factor is obtained by adding the Antenna Factor of 15.7 and a Cable Factor of 2.2 is added and subtracting the Amplifier Gain of 26.8 dB, giving a correction factor of -8.9 dB.

RESULT

In the configuration tested, the EUT complied with the requirements of the specification.

3.2.3 Labeling Requirements § 15.311

In addition to the labeling requirements of Section 15.19 (a) (3), all devices authorized under this subpart must bear a prominently located label with the following statement:

Installation of this equipment is subject to notification and coordination with UTAM, Inc. Any relocation of this equipment must be coordinated through, and approved by UTAM. UTAM may be contacted at telephone number 1-800-429-8826.

Demonstration of Compliance:

See labels in Exhibit 1 of this report.

3.2.4 Conducted Emissions § 15.315

An unlicensed PCS device that is designed to be connected to the public utility (AC) power line must meet the limits specified in § 15.207.

Frequency of Emission (MHz)	Conducted Limit (dBuV)	
	Quasi-peak	Average
0.15 - 0.5*	66 to 56*	56 to 46*
0.5 - 5	56	46
5 - 30	60	50

*Decreases with the logarithm of the frequency.

Measurement Data:

The PS3D operates on either batteries or via an AC battery charger therefore; the AC line conducted testing was performed with the PS3D powered from the AC battery charger.

EUT Configuration

The conducted emissions' testing was performed with the PS3D in the following configurations, idle mode, receive mode and transmit mode. The worst case emissions were with the PS3D in the transmit mode. Shown below are the conducted emissions from the PS3D in this worst case configuration.

A diagram of the test configuration is enclosed in Appendix A and a list of reference codes for test equipment used is enclosed in Appendix B.

Test equipment used: 1, 12 and 13.

Test Point	Frequency MHz	Detector	Measured Level dBµV	Limit dBµV
Hot Lead	0.16	Peak	43.2	55.7
	0.31	Peak	41.0	50.1
	0.52	Peak	33.7	46.0
	0.86	Peak	36.7	46.0
	1.37	Peak	36.7	46.00
	28.40	Peak	25.0	50.0
Neutral	0.15	Peak	43.0	56.0
	0.20	Peak	42.2	53.5
	0.35	Peak	39.5	48.9
	0.86	Peak	38.6	46.0
	1.37	Peak	39.0	46.0
	20.85	Peak	26.0	50.0

RESULT

In the configuration tested, the EUT complied with the requirements of the specification.

3.2.5 Antenna Requirement § 15.317**Demonstration of Compliance:**

The PS3D uses a permanently attached antenna. The same type as specified by the manufacturer can only replace this antenna (See Exhibit 12).

§ 15.319 General Technical Requirements

3.2.6 Frequency of Operation § 15.319 (a)**Demonstration of Compliance:**

The PS3D is an Isochronous device that transmits from 1920 - 1930 MHz. The spectrum has been split into eight 1.25 MHz sub-bands starting with 1920-1921.25 MHz and ending with 1928.75-1930 MHz. These channels are further sub-divided into the following channels:

Channel Number	Center Frequency (MHz)
1	1920.35
2	1920.65
3	1920.95
4	1921.55
5	1921.85
6	1922.15
7	1923.05
8	1923.35
9	1924.25
10	1924.55
11	1925.45
12	1925.75
13	1926.65
14	1926.95
15	1927.85
16	1928.15
17	1928.45
18	1929.05
19	1929.35
20	1929.65

The PS3D uses Time Division Multiple Access (TDMA) technology. Each channel is divided into 5 msec frame periods, which are further divided into eight time-slots of 625 μ sec per time-slot. The frame is divided in half, the first four slots of the frame are transmission slots, (ZT to PS) and the second four slots are receive slots (PS to ZT).

The base station performs all of the monitoring and assigning of the voice channel.

3.2.7 Digital Modulation Technique § 15.319 (b)

Demonstration of Compliance:

The PS3D uses a Differential Pi/4 QPSK Quadrature Phase Shift Keying digital modulation. The signal transmission rate is 384 kbit/s.

3.2.8 Peak Transmit Power and Emission Bandwidth § 15.319 (c)

Demonstration of Compliance:

The peak transmit power is determined by the following formula:

$$\text{Peak Transmit Power} = 100 \mu W \times \sqrt{BW}$$

BW = Emission Bandwidth in Hz.

The peak transmit power is required to be less than 17.3 dBm (as determined by the formula shown below).

$$\text{Peak Transmit Power} = 100 \mu W \times \sqrt{285000} = 53.38 mW = 17.3 dBM$$

Measurement Data:

The PS3D was tested as per ANSI C63.17-1998 Sections 6.1.2 and 6.1.3.

A diagram of the test configuration is enclosed in Appendix A and a list of reference codes for test equipment used is enclosed in Appendix B.

Test equipment used: 1 and 17.

Frequency (MHz)	Maximum Peak Transmit Power (dBm)	Measured Emission Bandwidth (kHz)
1920.35	14.1	287.4
1929.65	13.9	289.2

RESULT

In the configuration tested, the EUT complied with the requirements of the specification.

3.2.9 Power Spectral Density § 15.319 (d)**Requirement:**

Power spectral density shall not exceed 3 milliwatts in any 3 kHz bandwidth as measured with a spectrum analyzer having a resolution bandwidth of 3 kHz.

$$3 \text{ mW} = 4.7 \text{ dBm}$$

Measurement Data:

The PS3D was tested as per ANSI C63.17-1998 Section 6.1.5.

A diagram of the test configuration is enclosed in Appendix A and a list of reference codes for test equipment used is enclosed in Appendix B.

Test equipment used: 1 and 17.

Frequency (MHz)	Maximum Power Spectral Density - Sample Detection (dBm)
1920.35	2.5
1929.65	0.2

RESULT

In the configuration tested, the EUT complied with the requirements of the specification.

3.2.10 Directional Gain of Antenna § 15.319 (e)**Requirement:**

The peak transmit power shall be reduced by the amount in decibels that the maximum directional gain of the antenna exceeds 3 dBi.

Demonstration of Compliance:

The maximum directional antenna gain for the PS3D is 1.6 dBi.

3.2.11 Automatic Discontinuance of Transmission § 15.319 (f)**Requirement:**

The device shall automatically discontinue transmission on case of either absence of information to transmit or operational failure. The provisions in this section are not intended to preclude transmission of control and signaling information or use of repetitive codes used by certain digital technologies to complete frame or burst intervals.

Measurement Data:

The PS3D ceased to transmit under the following conditions:

1. The PS was placed in the on-hook mode
2. Removed power from ZT

3. Removed power from PBX
4. Removed interface line between PBX and base station
5. A call was placed from the PS to an analog extension, the extension was placed in the on-hook mode, both the ZT and the PS ceased to transmit after 30 seconds.

RESULT

In the configuration tested, the EUT complied with the requirements of the specification.

3.2.12 IEEE C95.1-1991 § 15.319 (i)**Requirement:**

The device must comply with IEEE C.95.1-1991, (ANSI/IEEE C.95.1-1992), "Safety Levels with Respect to Human Exposure to Radio Frequency Electromagnetic Fields, 3 kHz to 300 GHz". Measurement methods are specified in IEEE C95.3-1991, "Recommended Practice for the Measurement of Potentially Hazardous Electromagnetic Fields-RF and Microwave".

Measurement Data:

The PS3D is classified as a portable device. Therefore, the PS3D is subject to routine environmental evaluation for RF exposure as per § 2.1093(c).

Testing to demonstrate compliance to this section was performed by the University of Utah and the results of this test is enclosed in Exhibit 11.

§ 15.323 Specific Requirements for Isochronous Devices Operating in the 1920-1930 MHz sub-band**3.2.13 Channel Allocation § 15.323 (a)****Requirement:**

Operation shall be contained within one of eight 1.25 MHz channels starting with 1920-1921.25 MHz and ending with 1928.75-1930 MHz. Further sub-division of a 1.25 MHz channel is permitted with a reduced power level, as specified in § 15.319 (c), but in no event shall the emission bandwidth be less than 50 kHz.

Demonstration of Compliance:

The PS3D is an Isochronous device that transmits from 1920 - 1930 MHz. The spectrum has been split into eight 1.25 MHz sub-bands starting with 1920-1921.25 MHz and ending with 1928.75-1930 MHz. These channels are further sub-divided into the following channels:

Channel Number	Center Frequency (MHz)
1	1920.35
2	1920.65
3	1920.95
4	1921.55
5	1921.85
6	1922.15
7	1923.05
8	1923.35
9	1924.25
10	1924.55
11	1925.45
12	1925.75
13	1926.65
14	1926.95
15	1927.85
16	1928.15
17	1928.45
18	1929.05
19	1929.35
20	1929.65

The PS3D uses Time Division Multiple Access (TDMA) technology. Each channel is divided into 5 msec frame periods, which are further divided into eight time-slots of 625 μ sec per time-slot. The frame is divided in half, the first four slots of the frame are transmission slots, (ZT to PS) and the second four slots are receive slots (PS to ZT).

The base station performs all of the monitoring and assigning of the voice channel.

Measurement Data:

The PS3D was tested as per ANSI C63.17-1998 Section 6.1.3.

A diagram of the test configuration is enclosed in Appendix A and a list of reference codes for test equipment used is enclosed in Appendix B.

Test equipment used: 1 and 17.

Frequency (MHz)	Measured Emission Bandwidth (kHz)
1920.35	287.4
1929.65	289.2

RESULT

In the configuration tested, the EUT complied with the requirements of the specification.

3.2.14 Time and Spectrum Window § 15.323 (b)**Requirement:**

Intentional radiators with an intended emission bandwidth less than 625 kHz shall start searching for an available time and spectrum window within 3 MHz of the sub-band edge at 1920 MHz and search upward from that point. Devices with an intended emission bandwidth greater than 625 kHz shall start searching for an available time and spectrum window within 3 MHz of the sub-band edge at 1930 MHz and search downward from that point.

Demonstration of Compliance:

The base station (ZT) performs all of the time and spectrum window access monitoring and assigns the frequency channel and time slot for both the handset and base station. Therefore the monitoring tests and time and spectrum window access procedure tests were performed on the base station only. Shown below are the results of these tests.

Measurement Data:

The PS3D was tested as per ANSI C63.17-1998 Section 8.1.2.

A diagram of the test configuration is enclosed in Appendix A and a list of reference codes for test equipment used is enclosed in Appendix B.

Test equipment used: 1, 6, 7, 8, 9, and 17.

Step	Test Condition	Result
1	No Interference	Call Established channel 1 (1920.35 MHz)
2	Interference at lower threshold (-87.7 dBm) 3 MHz from lower edge of sub-band (1920-1923 MHz)	Call Established channel 7 (1923.05 MHz)
3	Interference at lower threshold (-87.7 dBm) 4 MHz from lower edge of sub-band (1920-1924 MHz)	Call Established channel 9 (1924.25 MHz)
4	No Interference	Call Established channel 1 (1920.35 MHz)
<p>Note: The control channel only operates on channels 1 through 6, if there is interference on all of these channels the ZT will not operate. For testing purposes the control channel was moved to channel 20 (1929.65 MHz).</p>		

RESULT

In the configuration tested, the EUT complied with the requirements of the specification.

3.2.15 Time and Spectrum Monitoring § 15.323 (c)

Requirement:

Isochronous devices must incorporate a mechanism for monitoring the time and spectrum windows that its transmission is intended to occupy. The following criteria must be met:

Demonstration of Compliance:

The base station (ZT) performs all of the time and

spectrum window access monitoring and assigns the frequency channel and time slot for both the handset and base station. Therefore the monitoring tests and time and spectrum window access procedure tests were performed on the base station only. Sections 4.2.16 through 4.2.26 of this report show compliance to FCC § 15.323 (c) (1) through § 15.323 (c) (12).

Enclosed below is an outline of how the system operates:

System Configuration

This system has three main devices. WCS(Wireless Communication System) is the call processing unit, ZT(Zone Transceiver) is the base station, and PS(Personal Station) is the portable handset.

This system uses the criteria of 15.323(c) (10). The initiating device is "ZT", and the responding device is "PS". The signal is transmitted between ZT and PS. Once the ZT is initiated, it communicates with PS periodically using the CONTROL CHANNEL(Cch). The CONTROL CHANNEL is broadcasted from the ZT to PS, and is randomly accessed from the PS to ZT, respectively as described below.

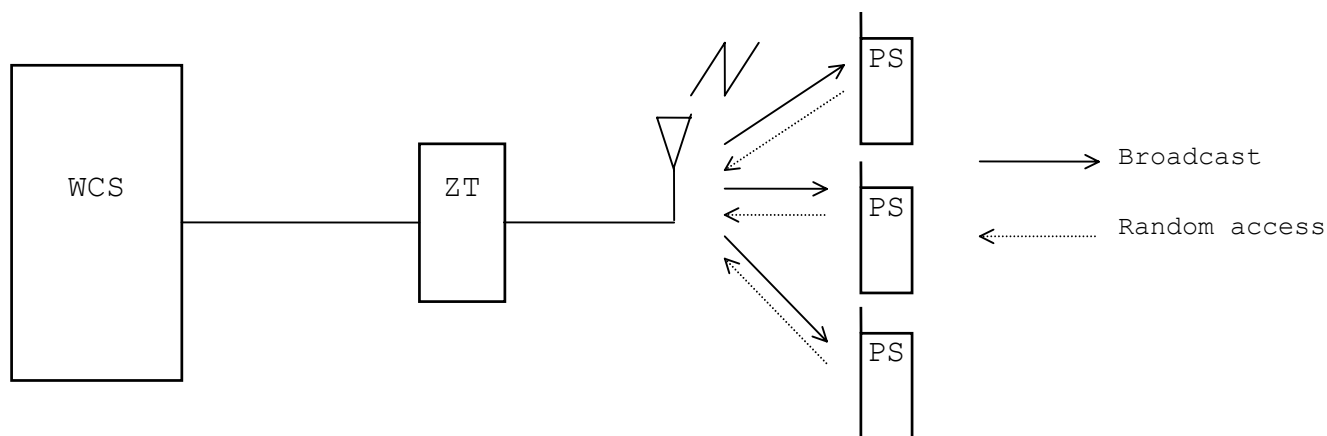
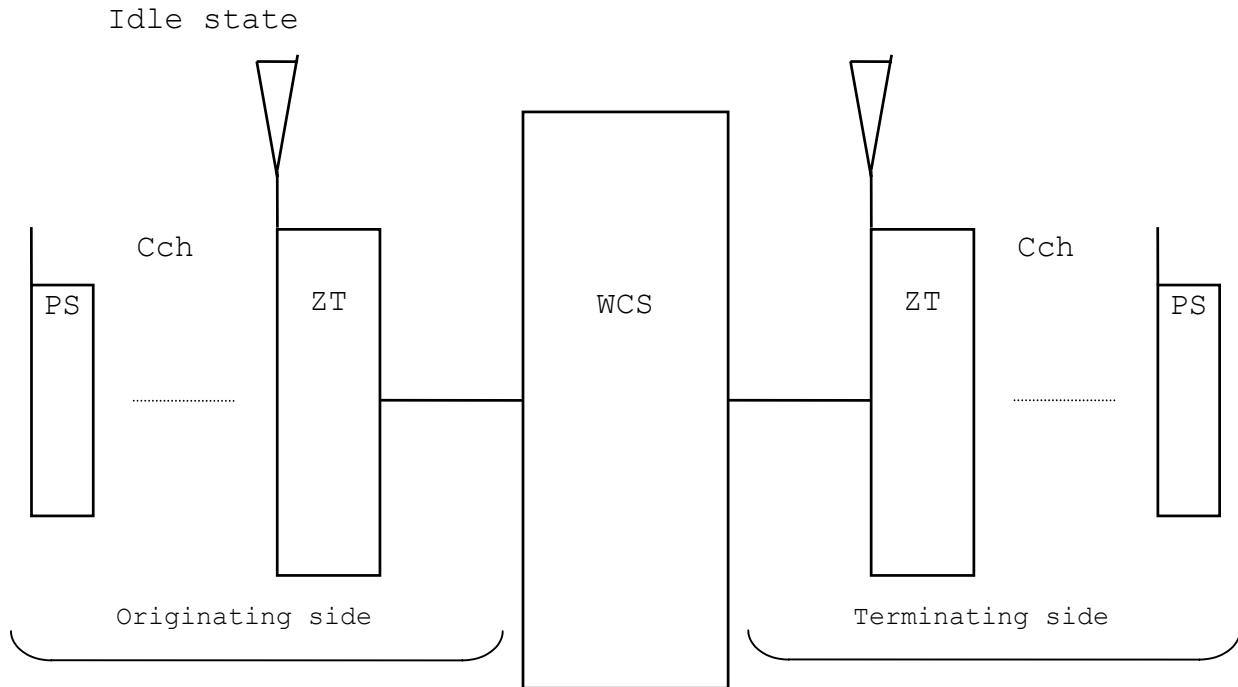

Fig. 1-1 CONTROL CHANNEL

When the PS(originating side) calls the other PS(terminating side) using CONTROL CHANNEL, PS(originating side) communicates with ZT(originating side) at first. After the link is established, COMMUNICATION CHANNEL(Tch) is used(Fig.1.2(b)). The ZT(originating side) sends the message to WCS. (see establishment of origination side communication channel).

Next, the ZT(terminating side) receives that message from

WCS, the communication is done between the PS(terminating side) and the ZT(terminating side) using CONTROL CHANNEL. After the link is established, COMMUNICATION CHANNEL is used(Fig.1.2(c)). (see establishment of terminating side communication channel).



Originating side linked state

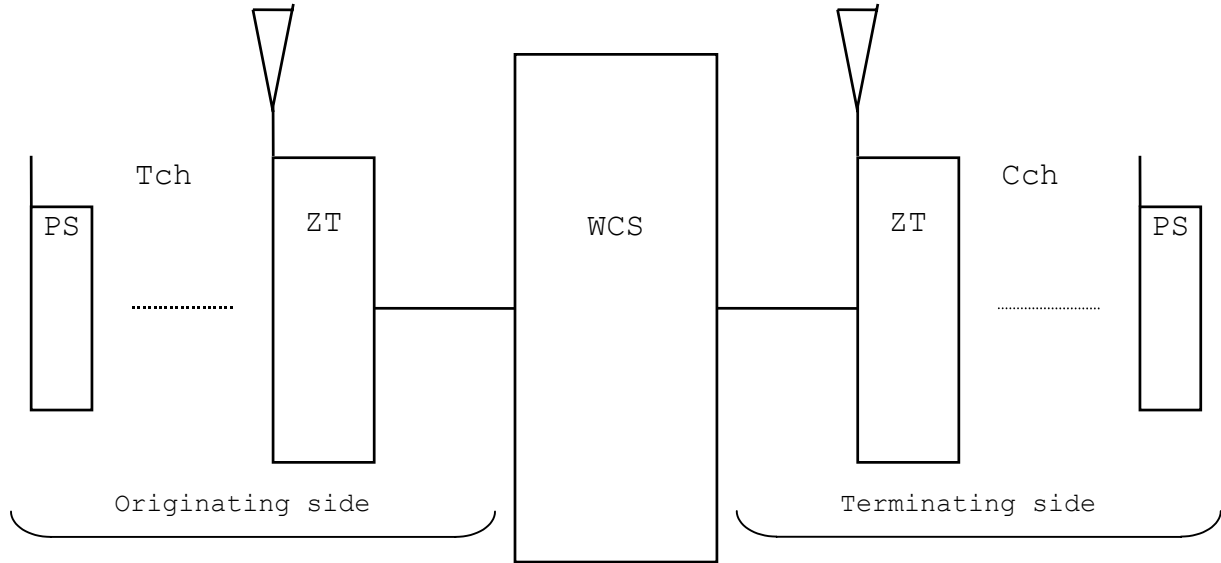

Terminating side linked state

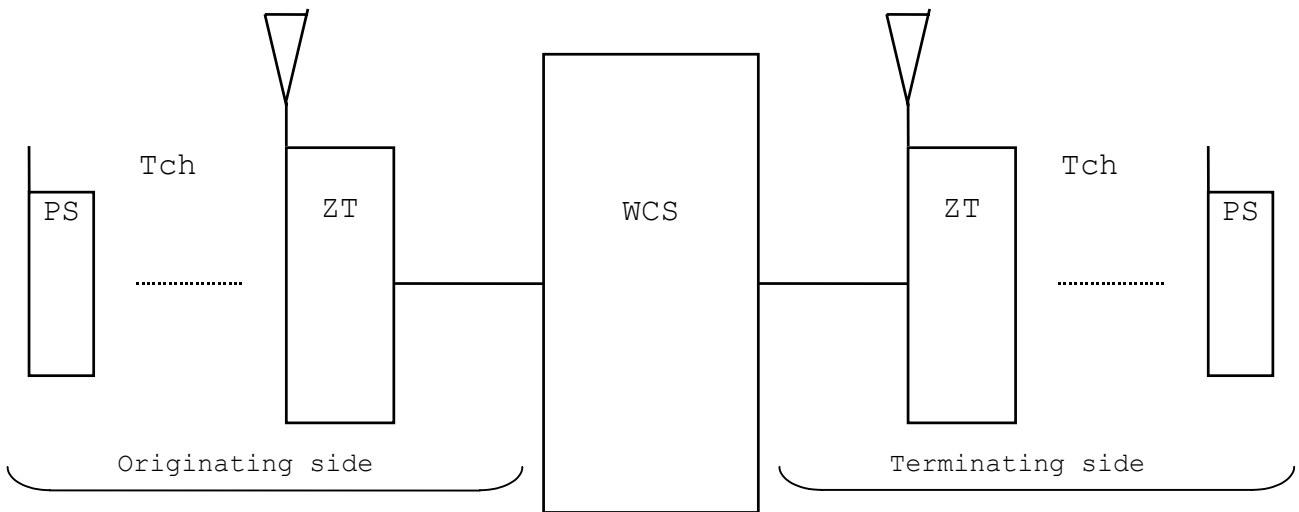

Fig. 1-2 COMMUNICATION CHANNEL and Connection

Frame structure

This section explains the structure of the FRAME transmitted between ZT and PS.

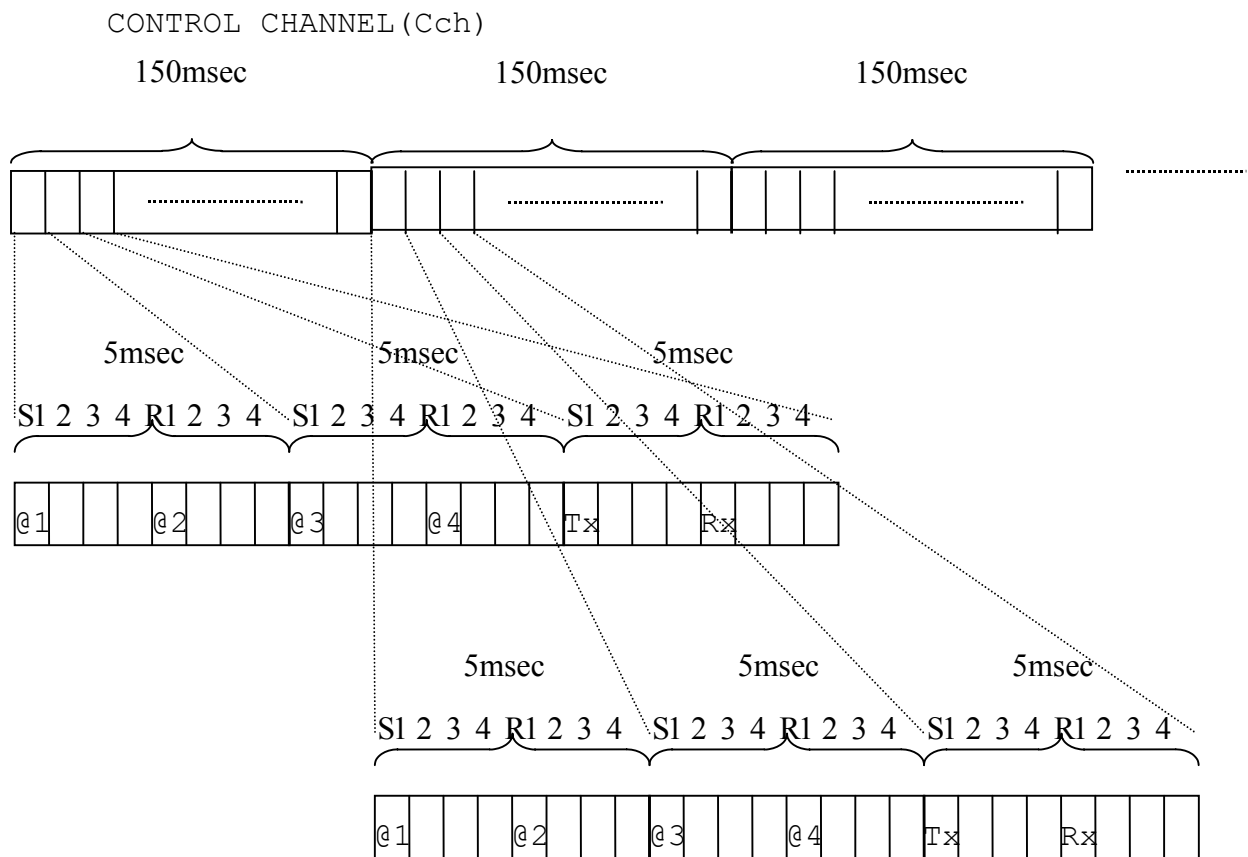

Fig. 1-3 FRAME structure of CONTROL CHANNEL

SLOT is the combined time and spectrum windows transmitted between ZT and PS.

FRAME is structured with 4 transmitting SLOT and 4 receiving SLOT shown in Fig.1.3. It is a period of 5msec (625μsec×8). The FRAME used for CONTROL CHANNEL periodically transmitting at 150msec. CONTROL CHANNEL is sent at S1 SLOT and received at R1 SLOT in figure1.3.

Immediately prior to initiating transmission, ZT always monitors SLOTS(point "@" of Fig1.3) in which it intend to

transmit for a period of 10msec. That is why, one CONTROL CHANNEL occupies a period of 15msec at that carrier. Therefore, it is possible to use 10 CONTROL CHANNELS at same carrier. The PS is synchronized with ZT while it is receiving CONTROL CHANNEL periodically in every 150msec. Several PSs can be synchronized with one ZT.

Synchronized PS requests a call by sending the message on the upward of the CONTROL CHANNEL(point Rx of Fig.1.3). The other side, synchronized PS accepts a call by receiving the message on downward of the CONTROL CHANNEL(point Tx of Fig.1.3). Rx is random access. Tx is broadcast.

COMMUNICATION CHANNEL

* * *

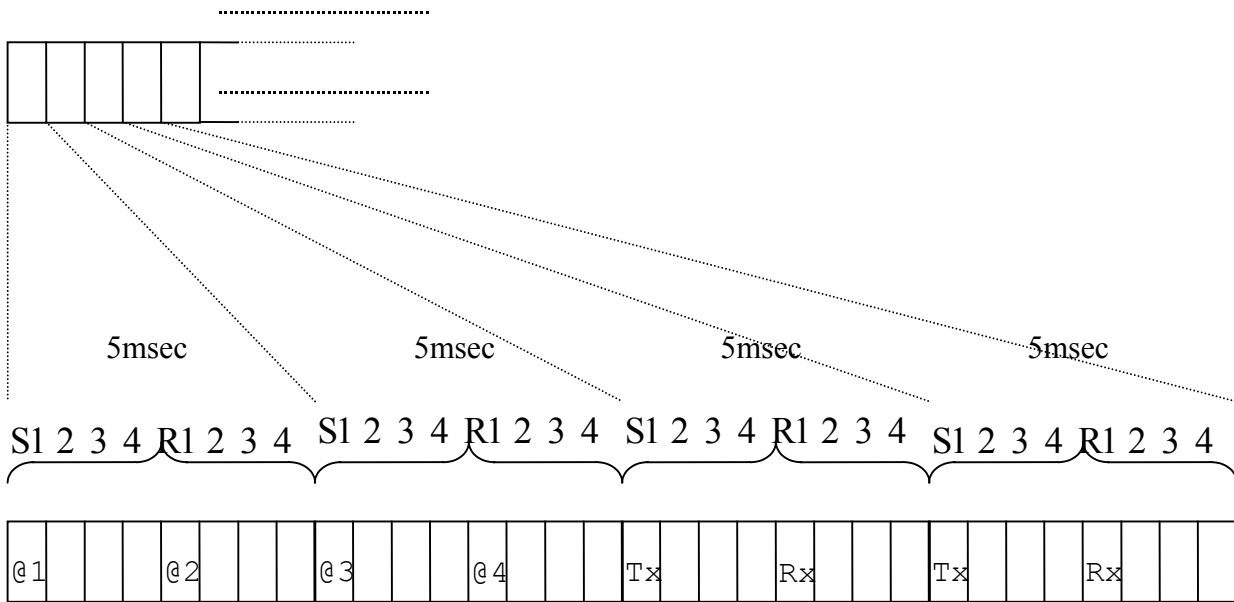

Fig. 1-4 FRAME structure of COMMUNICATION CHANNEL

SLOT is the combined time and spectrum windows transmitted between ZT and PS.

FRAME is structured with 4 transmitting SLOT and 4 receiving SLOT shown in Fig.1.3. It is a period of 5msec (625μsecx8). The FRAME used for COMMUNICATION CHANNEL periodically transmitting at 5msec. The COMMUNICATION CHANNEL is transmitted from ZT using S2,S3 or S4 SLOT in Fig.1.4. And it is transmitted from PS to ZT using R2,R3 or R4 SLOT in Fig.1.4. Therefore, it is possible to use 3 COMMUNICATION CHANNELS at the same carrier.

CONTROL CHANNEL

The action of CONTROL CHANNEL has 2 phase, one is the initiating phase and the other is the broadcasting phase. Initiating phase is the selecting FRAME of CONTROL CHANNEL. Broadcasting phase comes after initiating phase. ZT sends and receives message to/from PS in this phase. These two phase are explained as follows.

Initiating phase (monitoring and selecting of CONTROL CHANNEL)

When ZT is initiated, ZT tries to select a FRAME of CONTROL CHANNEL. If no interference is detected, ZT uses that FRAME. Following is a flowchart.

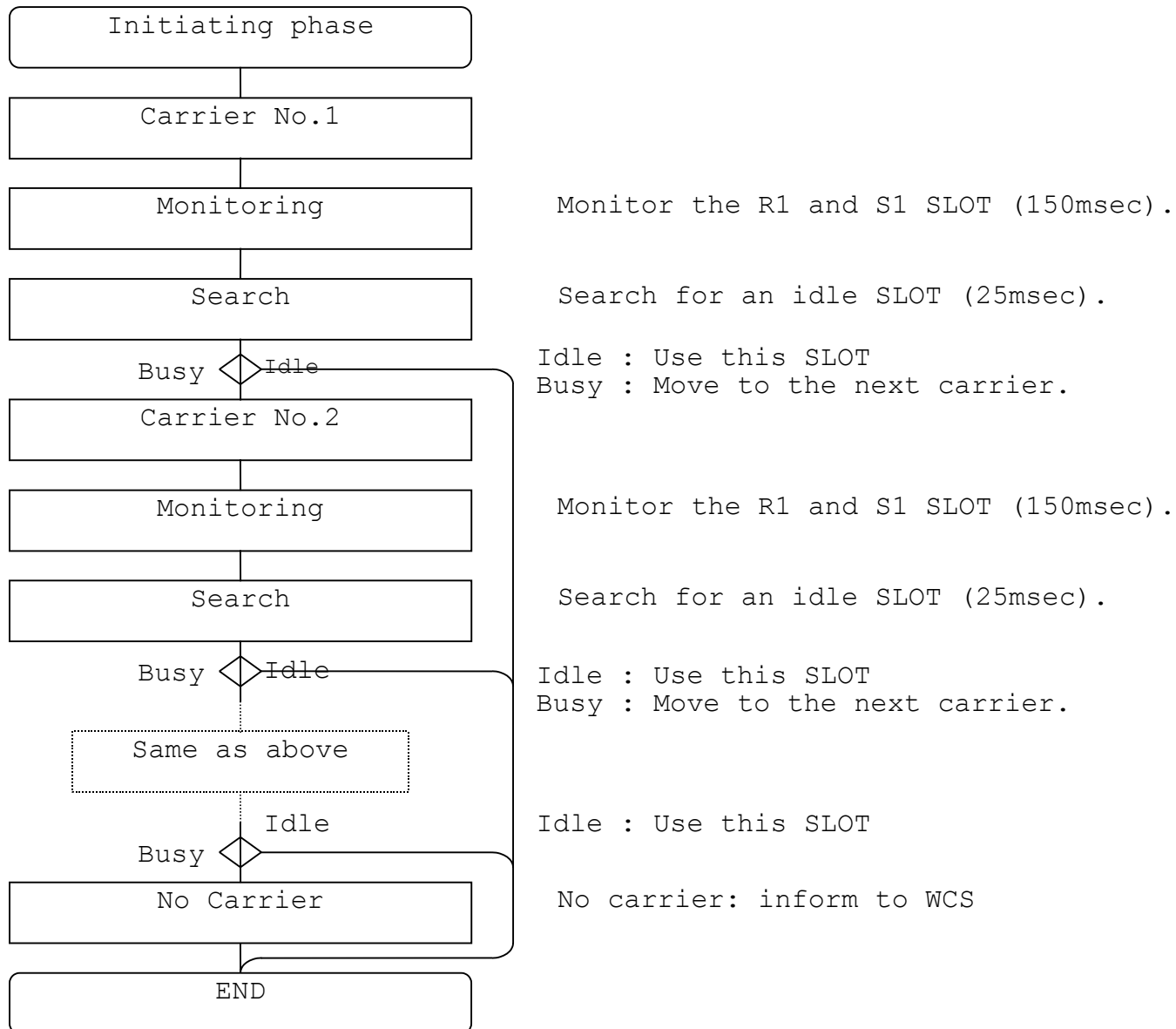

Broadcasting phase(Radiating of CONTROL CHANNEL)

If ZT finds an idle SLOT of control channel, ZT sends and receives message in every 150msec. ZT monitors SLOT for 10msec prior to radiating carrier according to 15.323(c) (1). If ZT finds an interference , then stops its broadcasting and starts to monitor again using process 2.1.Following is a flowchart. (Please refer to Fig.1.3.)

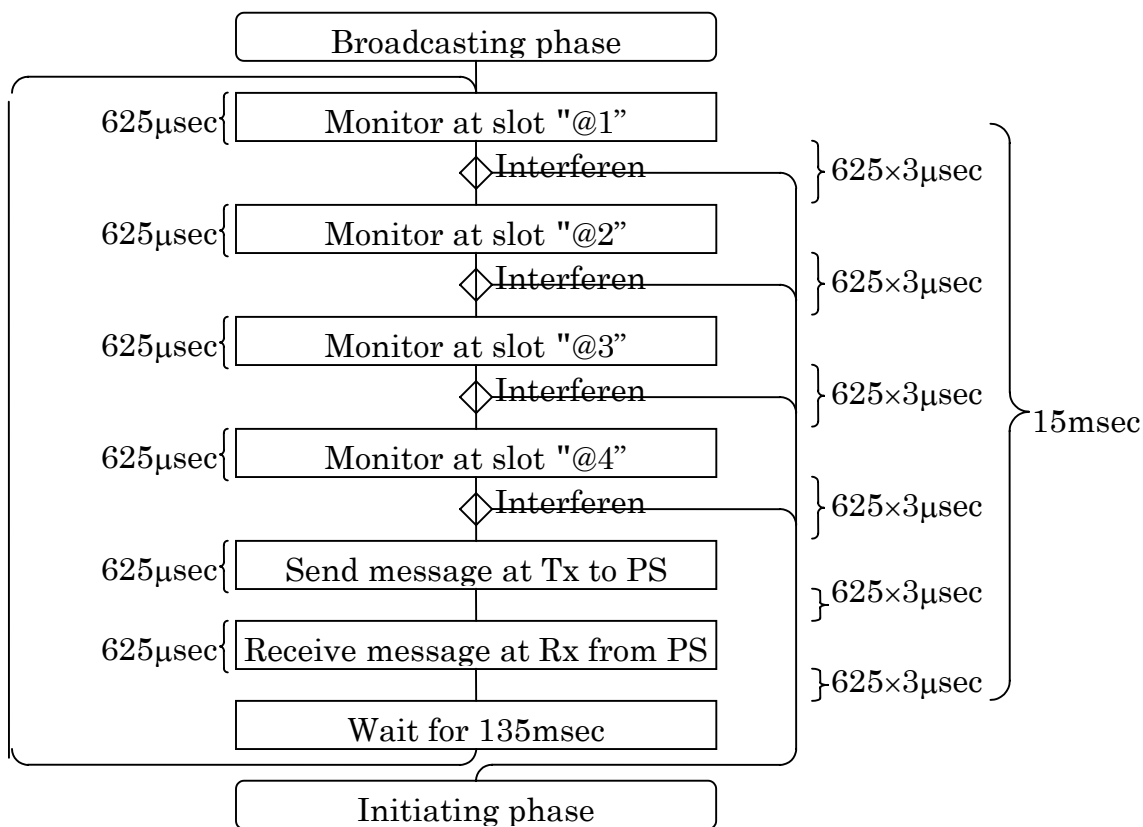

COMMUNICATION CHANNEL

After ZT is initiated, ZT collects the idle information of COMMUNICATION CHANNELS periodically. This function is called "IDLE CARRIER SENSE". ZT has a table which is called "IDLE CARRIER SENSE TABLE". It reflects the idle state of each SLOT, as shown below.

Idle carrier sense

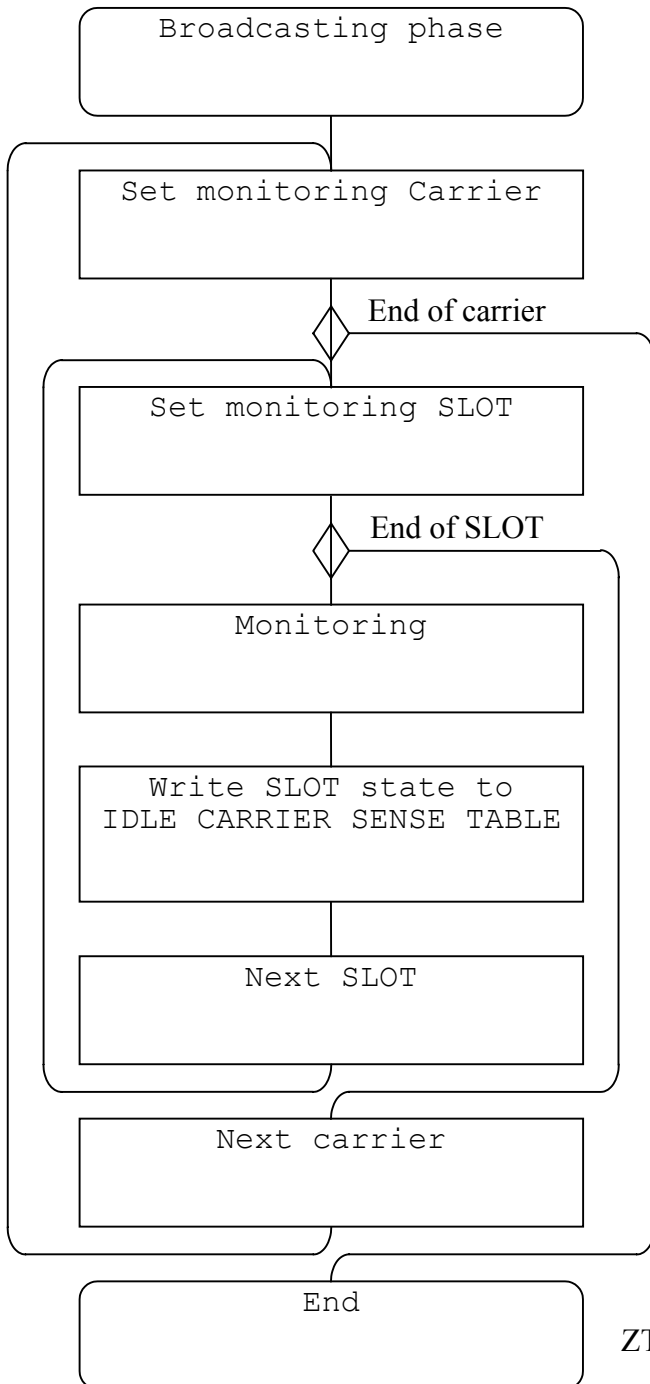

Struct of IDLE CARRIER SENSE TABLE

Carrier (MHz)	SLOT		
	2	3	4
1920.35	IDLE	BUSY	IDLE
1920.65	BUSY	BUSY	IDLE
:	:	:	:
:	:	:	:
:	:	:	:
1929.65	IDLE	IDLE	IDLE

ZT starts "CARRIER SENSE" from first carrier again.

COMMUNICATION CHANNEL carrier sense time chart

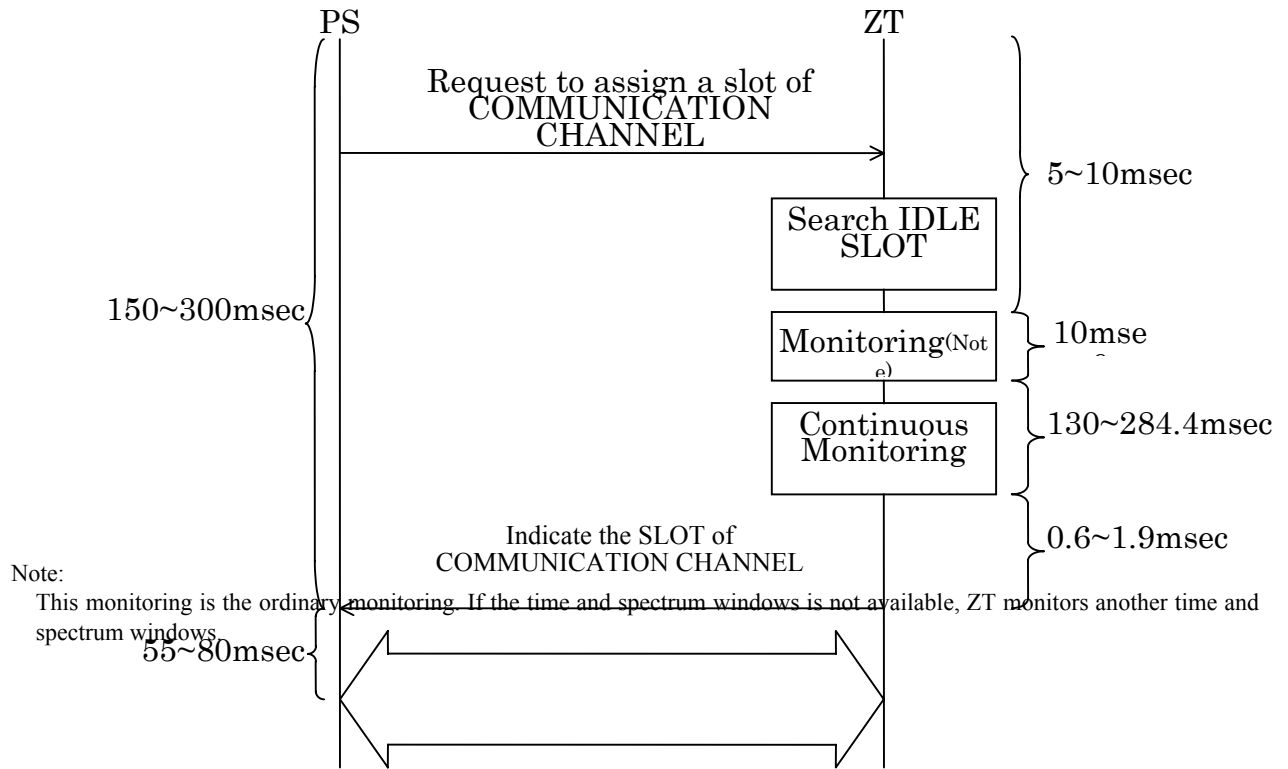

Disconnect sequence time chart

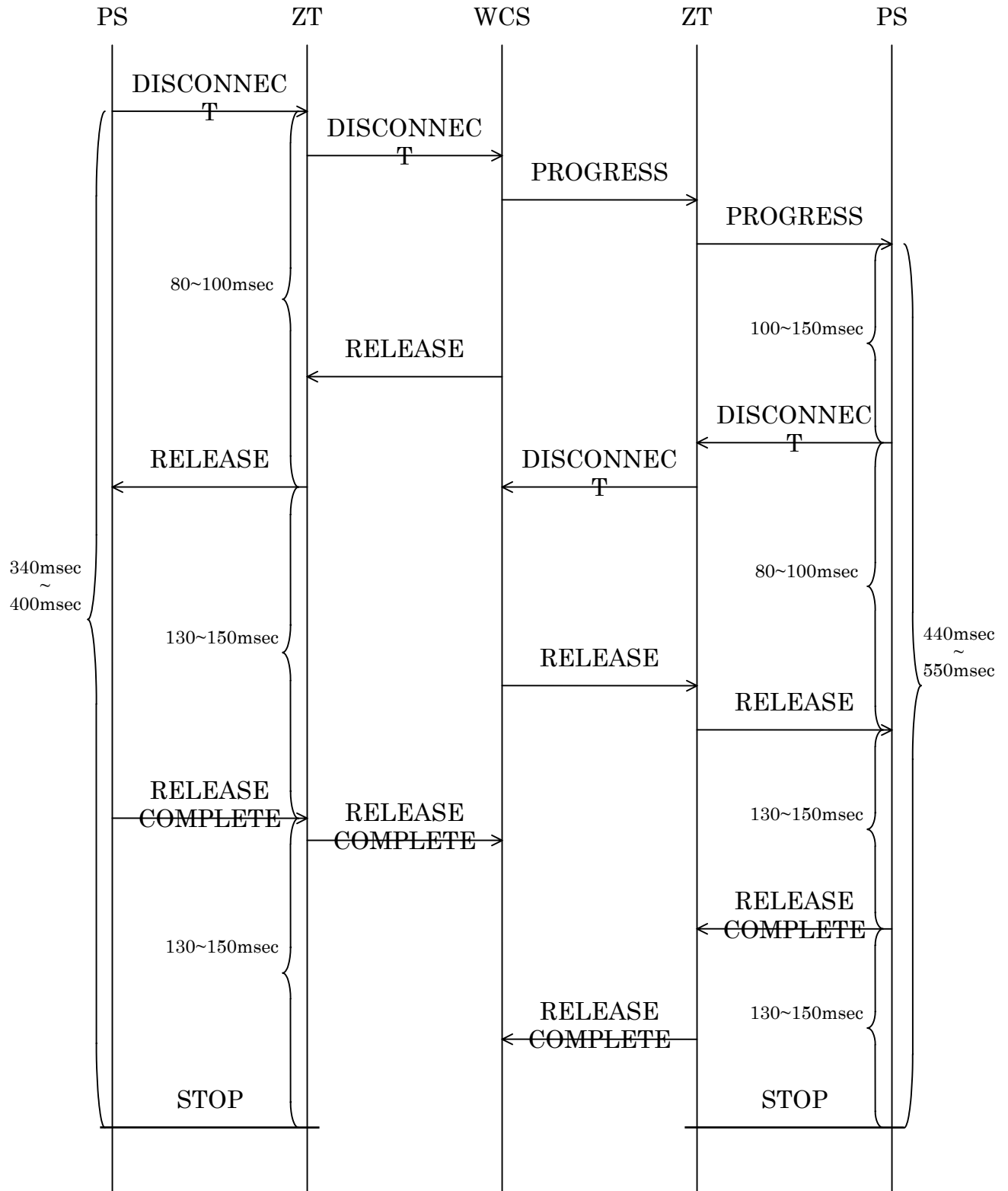

3.2.16 Isochronous Reaction Time and Monitoring Interval**§ 15.323 (c) (1)****Requirement:**

Immediately prior to initiating a transmission, devices must monitor the combined time and spectrum windows in which they intend to transmit for a period of at least 10 milliseconds for systems designed to use a 10 milliseconds or shorter time frame period or at least 20 milliseconds for systems designed to use a 20 milliseconds frame period.

Measurement Data:

To verify that the device was operating as described above the SN933 WEK-A was tested as per ANSI C63.17-1998 Sections 7.3.2.2 and 7.5.

A diagram of the test configuration is enclosed in Appendix A and a list of reference codes for test equipment used is enclosed in Appendix B.

Test equipment used: 22, 6, 23, 24, 25, 26 and 30.

ANSI C63.17 Section 7.3.2.2

Shown below are two timing diagram from a logic analyzer that verifies that the ZT monitors the time and spectrum window for 10 milliseconds immediately prior to transmitting. Plot #1 shows interference on all time slots except slot 1; therefore, the control channel transmitted after monitoring the time and spectrum windows for 10 milliseconds. Plot #2 shows interference on all time slots; therefore, the control channel did not transmit.

Slot 1 and Slot 2 show the transmit and receive slots.

Slot 1 "low" and Slot 2 "low" = ZT slot 1

Slot 1 "high" and Slot 2 "low" = ZT slot 2

Slot 1 "low" and Slot 2 "high" = ZT slot 3

Slot 1 "high" and Slot 2 "high" = ZT slot 4

TX SLT = ZT transmit and receive slots

"high" = TX "low" = RX

TX = Control channel

"low" = no transmission "high" = transmission

IN_F = Interference

Plot #1

Analyzer	Waveform MACHINE 1	Acq. Control	Cancel	Stop	
Accumulate Off	SLOT1 X -> 0			Center Screen	
	Hex 0 -> 0				
sec/Div 2.00 ms	Delay 6.240 ms	Markers Time	X to 0 10.00 ms	Trig to X 560.0 us	Trig to 0 10.56 ms

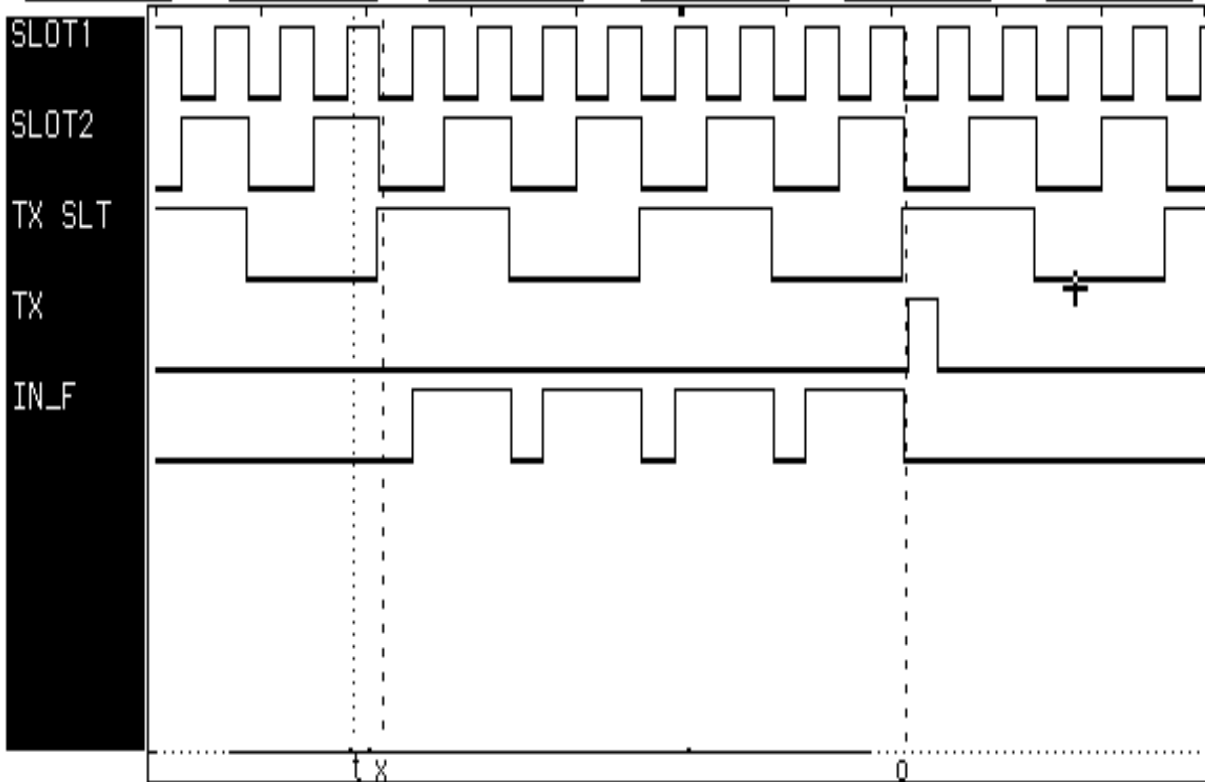

Plot #2

Analyzer	Waveform MACHINE 1	Acq. Control	Cancel	Stop	
Accumulate Off	SLOT1 X -> 0			Center Screen	
	Hex 0 -> 0				
sec/Div 2.00 ms	Delay 6.240 ms	Markers Time	X to 0 10.00 ms	Trig to X 560.0 us	Trig to 0 10.56 ms

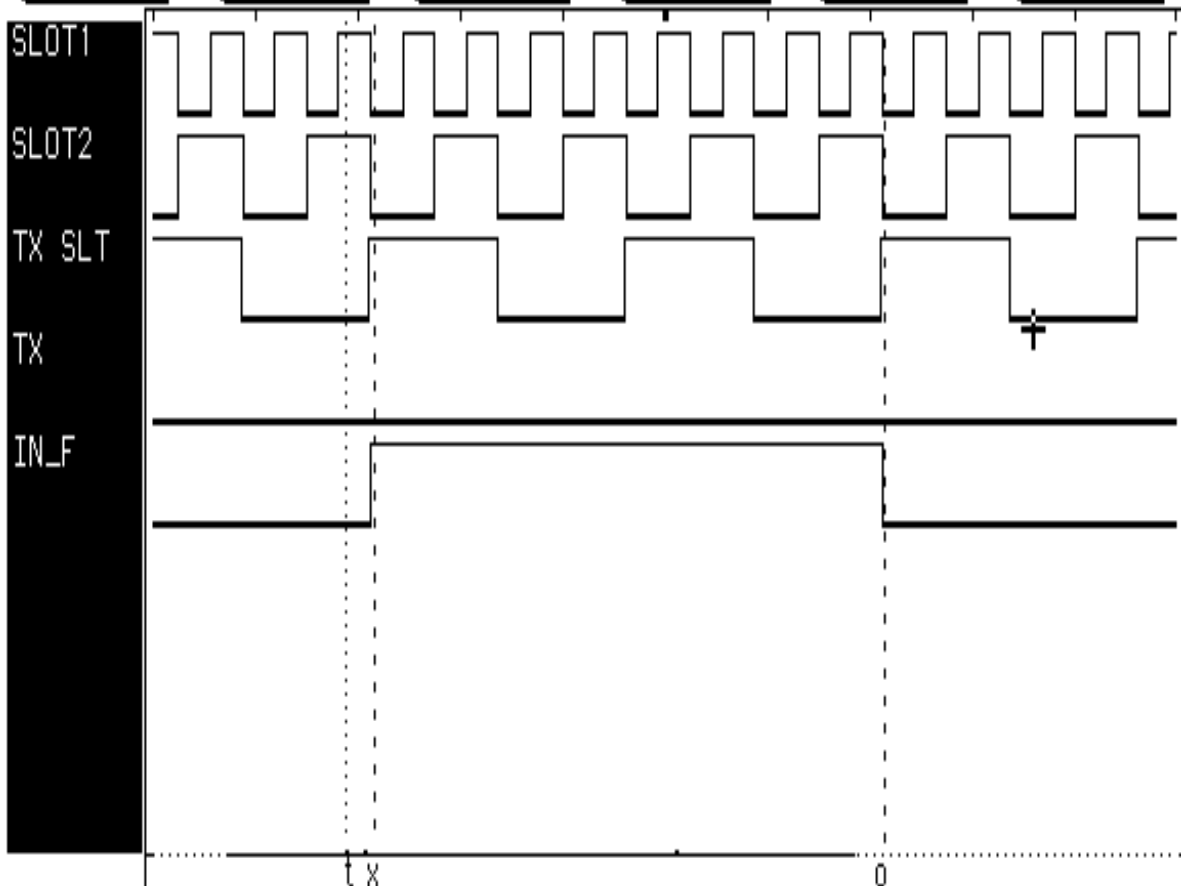

ANSI C63.17 Section 7.3.2.2

To test for this section two channels were made interference free, the remaining channels had interference so that they were unavailable. The two channels that were interference free were designated as f1 (channel 1 1920.35 MHz) and f2 (channel 6 1922.15 MHz). The test set-up allowed interference to be placed on f1 and f2 independent of each other.

Step	Test Condition	Result
1	No Interference	Call Established f1 (channel 1 1920.35 MHz)
2	Interference on f1 3 dB above threshold and interference on f2 10 dB above threshold	No Call Established
3	Interference on f2 removed (f2 available)	Call Established f2 (channel 6 1922.15 MHz)
4	Connection terminated	No Call Established
5	Interference on f2 re- applied, EUT attempted transmission	Call Established f1 (channel 1 1920.35 MHz)

ANSI C63.17 Section 7.5

To test for this section two channels were made interference free, the remaining channels had interference so that they were unavailable. The two channels that were interference free were channel 1 (1920.35 MHz) channel 6 (1922.15 MHz).

Step	Test Condition	Result
1	No Interference	Call Established channel 1
2	Interference on Channel 1 at threshold level, pulse modulated with 102.8 :s pulse width	No Call Established on channel 1, call established on channel 6

Step	Test Condition	Result
3	Interference on Channel 1 6 dB above threshold level, pulse modulated with 72.0 :s pulse width	No Call Established on channel 1, call established on channel 6
4	Interference on Channel 1 10 dB above threshold level, pulse modulated with 154.3 :s pulse width	No Call Established on channel 1, call established on channel 6
5	Step 4 was repeated 5 times with the synchronization of the pulsed interference randomly varied with respect to the EUT frame.	No Call Established on channel 1, call established on channel 6
6	No Interference	Call Established channel 1

SAMPLE CALCULATIONS

$$Pulse\ Width = 35\sqrt{1.25 / B}$$

$$Pulse\ Width = 50\sqrt{1.25 / B}$$

$$Pulse\ Width = 75\sqrt{1.25 / B}$$

Where B = Emission Bandwidth in MHz

$$Pulse\ Width = 35\sqrt{1.25 / 0.2988} = 65.5\ \mu\text{sec}$$

$$Pulse\ Width = 50\sqrt{1.25 / 0.2988} = 102.3\ \mu\text{sec}$$

$$Pulse\ Width = 75\sqrt{1.25 / 0.2988} = 153.4\ \mu\text{sec}$$

RESULT

In the configuration tested, the EUT complied with the requirements of the specification.

3.2.17 Monitoring Threshold § 15.323 (c) (2)**Requirement:**

The monitoring threshold must not be more than 30 dB above the thermal noise power for a bandwidth equivalent to the emission bandwidth used by the device.

Demonstration of Compliance:

The SN933 WEK-A operates in the Listen Before Talk (LBT) mode only and does not use the Least Interfered Channel (LIC) mode. Shown below is the calculation for the LBT threshold level:

$$\text{Threshold Level for Isochronous (LBT) devices} = 15\log_{10} B - 184 + 30 - P \text{ dBm}$$

B = Emission Bandwidth (Hz)

P = Measured Transmitter Power Level (dBm)

$$\text{Threshold Level for Isochronous (LBT) devices} = 15\log_{10} 295500 - 184 + 30 - 15.8 = -87.7 \text{ dBm}$$

Measurement Data:

The SN933 WEK-A was tested as per ANSI C63.17-1998 Section 7.3.2.1.

A diagram of the test configuration is enclosed in Appendix A and a list of reference codes for test equipment used is enclosed in Appendix B.

Test equipment used: 1, 6, 7, 8, 9, and 17.

ANSI C63.17 Section 7.3.2.1

Since the SN933 WEK-A does not use the LIC threshold, the following steps were performed to measure the threshold level and verify that the threshold level did not exceed -87.7 dBm as calculated above.

To test for this section two channels were made interference free, the remaining channels had interference so that they were unavailable. The two channels that were interference free were

designated as f1 (channel 1 1920.35 MHz) and f2 (channel 6 1922.15 MHz). The test set-up allowed interference to be placed on f1 and f2 independent of each other.

Step	Test Condition	Result
1	No Interference	Call Established f1 (channel 1 1920.35 MHz)
2	Interference on f1 10 dB below threshold level (calculated)	Call Established f1 (channel 1 1920.35 MHz)
3	Interference level on f1 increased 1 dB	Call Established f1 (channel 1 1920.35 MHz)
4	Step 3 repeated until the call was established on f2	Call Established f2 (channel 1 1922.15 MHz)
5	Interference level on f1 reduced 1 dB	Call Established f1 (channel 1 1920.35 MHz)
6	Interference level on f1 increased 1 dB	Call Established f2 (channel 1 1922.15 MHz)
7	Steps 5 and 6 repeated 5 times	Same as steps 5 and 6
8	Threshold level measured	Threshold level = -88.0 dBm
9	Interference on f1 and f2 at the calculated threshold. The interference on f1 occurred only during the transmit portion of the frame	No Call Established
10	No Interference	Call Established f1 (channel 1 1920.35 MHz)

RESULT

In the configuration tested, the EUT complied with the requirements of the specification.

3.2.18 Transmission Duration § 15.323 (c) (3)**Requirement:**

If no signal above the threshold level is detected, transmission may commence and continue with the same emission bandwidth in the monitored time and spectrum windows without further monitoring. However, occupation of the same combined time and spectrum windows by a device or group of cooperating devices continuously over a period of time longer than 8 hours is not permitted without repeating the access criteria.

Demonstration of Compliance:

The handset incorporates a software program that does not allow the PS to transmit longer than 8 hours. The ZT stops transmitting within 1.5 seconds once the voice call from the PS has been terminated, as demonstrated in Section 4.2.19 of this report (ANSI Section 8.2.1); therefore, the ZT and the PS comply with this requirement.

Measurement Data:

A call was placed from the handset to the base station to monitor the duration of each call. The base station and handset were connected to a modulation domain analyzer that monitored the time that the call was started and when the call was disconnected. Both the base station and the handset stopped transmitting after 7 hours and 50 minutes.

RESULT

In the configuration tested, the EUT transmitted for less than 8 hours; therefore, the EUT complied with the requirements of the specification.

3.2.19 Acknowledgments § 15.323 (c) (4)**Requirement:**

Once access to specific combined time and spectrum windows is obtained an acknowledgment from a system participant must be received by the initiating transmitter within one second or transmission must cease. Periodic acknowledgments must be received at least every 30 seconds or transmission must cease. Channels used exclusively for control and signaling information may transmit continuously for 30 seconds without receiving an acknowledgment, at which time the access criteria must be repeated.

Measurement Data:

The SN933 WEK-A was tested as per ANSI C63.17-1998 Sections 8.1.3 and 8.2.1.

A diagram of the test configuration is enclosed in Appendix A and a list of reference codes for test equipment used is enclosed in Appendix B.

Test equipment used: 22, 23 and 25.

Demonstration of Compliance Section 8.1.3

Step	Test Condition	Result
1	Interference on all time and frequency channels except channel 1 time slot 1	Control channel transmitting on Channel 1 (1920.35 MHz)
2	Interference on all channels	No control channel transmitting
3	Interference removed, time from end of interference to start of control channel transmission measured	See results below
4	Steps 2 and 3 repeated 5 times	See results below

Attempt	Time sec
1	2.40
2	0.885
3	0.510
4	8.15
5	4.60

All 5 of these measurements are greater than 150 msec; therefore, the EUT meets the requirements of this section.

ANSI C63.17 Section 8.2.1

After an available time/spectrum window has been assigned both the base station and handset attempt to transmit on the specified time/spectrum window. If either device does not receive an acknowledgment, from the other device, within one second the EUT ceases to transmit. After the call is established if there is not an acknowledgment received, every 30 seconds, from the other device transmission is ceased.

Step	Test Condition	Result
1	Voice call initiated by the handset, the power to the handset turned off	Base station stopped transmission within 1.5 sec
2	Voice call initiated by the handset, the power to the base station turned off	Handset stopped transmission after 30 sec
3	Voice call initiated, to the handset, by an analog telephone that was connected to the PBX, the analog phone was placed in the on-hook mode	Handset stopped transmission after 30 sec
4	Handset activated with base station turned off	Handset did not transmit for more than 1 sec
5	Base station activated with handset turned off	Base station did not transmit for more than 1 sec

RESULT

In the configuration tested, the EUT complied with the requirements of the specification.

3.2.20 Monitoring Threshold for Systems with a Minimum of 40 Duplex Channels § 15.323 (c) (5)**Requirement:**

If access to spectrum is not available as determined by the above, and a minimum of 40 duplex system access channels are defined for the system, the time and spectrum windows with the lowest power level below a monitoring threshold of 50 dB above the thermal noise power determined for the emission bandwidth may

be accessed. A device utilizing the provisions of this paragraph must have monitored all access channels defined for its system within the last 10 seconds and must verify, within the 20 milliseconds (40 milliseconds for devices designed to use a 20 milliseconds frame period) immediately preceding actual channel access that the detected power of the selected time and spectrum windows is no higher than the previously detected value. The power measurement resolution for this comparison must be accurate to within 6 dB. No device or group of cooperating devices located within 1 meter of each other shall occupy more than three 1.25 MHz channels during any frame period. Devices in an operational state that are utilizing the provisions of this section are not required to use the search provisions of paragraph (b) of this section.

Demonstration of Compliance:

The SN933 WEK-A does not use the provisions of this section (LIC), it only uses the LBT mode. There are no devices or group of cooperating devices located within 1 meter of each other, this is specified in the installation manual. Testing to demonstrate compliance with this section is the same as § 15.323 (c) (1), shown below are the results of these tests.

Measurement Data:

The SN933 WEK-A was tested as per ANSI C63.17-1998 Sections 7.3.2.1, 7.3.2.2 and 8.2.1.

A diagram of the test configuration is enclosed in Appendix A and a list of reference codes for test equipment used is enclosed in Appendix B.

Test equipment used: 22, 6, 23, 24, and 25.

ANSI C63.17 Section 7.3.2.1

Since the SN933 WEK-A does not use the LIC threshold, the following steps were performed to measure the threshold level and verify that the threshold level did not exceed -87.7 dBm as calculated above.

To test for this section two channels were made interference free, the remaining channels had interference so that they were unavailable. The two channels that were interference free were designated as f1 (channel 1 1920.35 MHz) and f2 (channel 6 1922.15 MHz). The test set-up allowed interference to be placed on f1 and f2 independent of each other.

Step	Test Condition	Result
1	No Interference	Call Established f1 (channel 1 1920.35 MHz)
2	Interference on f1 10 dB below threshold level (calculated)	Call Established f1 (channel 1 1920.35 MHz)
3	Interference level on f1 increased 1 dB	Call Established f1 (channel 1 1920.35 MHz)
4	Step 3 repeated until the call was established on f2	Call Established f2 (channel 1 1922.15 MHz)
5	Interference level on f1 reduced 1 dB	Call Established f1 (channel 1 1920.35 MHz)
6	Interference level on f1 increased 1 dB	Call Established f2 (channel 1 1922.15 MHz)
7	Steps 5 and 6 repeated 5 times	Same as steps 5 and 6
8	Threshold level measured	Threshold level = -88.0 dBm
9	Interference on f1 and f2 at the calculated threshold. The interference on f1 occurred only during the transmit portion of the frame	No Call Established
10	No Interference	Call Established f1 (channel 1 1920.35 MHz)

ANSI C63.17 Section 7.3.2.2

To test for this section two channels were made interference free, the remaining channels had interference so that they were unavailable. The two channels that were interference free were designated as f1 (channel 1 1920.35 MHz) and f2 (channel 6 1922.15 MHz). The test set-up allowed interference to be placed on f1 and f2 independent of each other.

Step	Test Condition	Result
1	No Interference	Call Established f1 (channel 1 1920.35 MHz)
2	Interference on f1 3 dB above threshold and interference on f2 10 dB above threshold	No Call Established
3	Interference on f2 removed (f2 available)	Call Established f2 (channel 6 1922.15 MHz)
4	Connection terminated	No Call Established
5	Interference on f2 re- applied, EUT attempted transmission	Call Established f1 (channel 1 1920.35 MHz)

ANSI C63.17 Section 8.2.1

After an available time/spectrum window has been assigned both the base station and handset attempt to transmit on the specified time/spectrum window. If either device does not receive an acknowledgment, from the other device, within one second the EUT ceases to transmit. After the call is established if there is not an acknowledgment received, every 30 seconds, from the other device transmission is ceased.

Step	Test Condition	Result
1	Voice call initiated by the handset, the power to the handset turned off	Base station stopped transmission within 1.5 sec
2	Voice call initiated by the handset, the power to the base station turned off	Handset stopped transmission after 30 sec
3	Voice call initiated, to the handset, by an analog telephone that was connected to the PBX, the analog phone was placed in the on-hook mode	Handset stopped transmission after 30 sec
4	Handset activated with base station turned off	Handset did not transmit for more than 1 sec
5	Base station activated with handset turned off	Base station did not transmit for more than 1 sec

RESULT

In the configuration tested, the EUT complied with the requirements of the specification.

3.2.21 Isochronous Random Waiting Interval § 15.323 (c) (6)**Requirement:**

If the selected combined time and spectrum windows are unavailable, the device may either monitor and select different windows or seek to use the same windows after waiting an amount of time, randomly chosen from a uniform random distribution between 10 and 150 milliseconds, commencing when the channel becomes available.

Measurement Data:

The SN933 WEK-A was tested as per ANSI C63.17-1998 Section 8.1.3.

A diagram of the test configuration is enclosed in Appendix A and a list of reference codes for test equipment used is enclosed in Appendix B.

Test equipment used: 22, 23 and 25.

Demonstration of Compliance Section 8.1.3

Step	Test Condition	Result
1	Interference on all time and frequency channels except channel 1 time slot 1	Control channel transmitting on Channel 1 (1920.35 MHz)
2	Interference on all channels	No control channel transmitting
3	Interference removed, time from end of interference to start of control channel transmission measured	See results below
4	Steps 2 and 3 repeated 5 times	See results below

Attempt	Time sec
1	2.40
2	0.885
3	0.510
4	8.15
5	4.60

All 5 of these measurements are greater than 150 msec; therefore, the EUT meets the requirements of this section.

RESULT

In the configuration tested, the EUT complied with the requirements of the specification.

ANSI C63.17 Section 8.2.1

After an available time/spectrum window has been assigned both the base station and handset attempt to transmit on the specified time/spectrum window. If either device does not receive an acknowledgment, from the other device, within one second the EUT ceases to transmit. After the call is established if there is not an acknowledgment received, every 30 seconds, from the other device transmission is ceased.

Step	Test Condition	Result
1	Voice call initiated by the handset, the power to the handset turned off	Base station stopped transmission within 1 sec
2	Voice call initiated by the handset, the power to the base station turned off	Handset stopped transmission after 1 sec
3	Voice call initiated, to the handset, by an analog telephone that was connected to the base station, the analog phone was placed in the on-hook mode	Handset stopped transmission after 2 sec
4	Handset activated with base station turned off	Handset did not transmit for more than 1 sec

Step	Test Condition	Result
5	Base station activated with handset turned off	Base station did not transmit for more than 1 sec

RESULT

In the configuration tested, the EUT complied with the requirements of the specification.

3.2.22 Threshold Monitoring Bandwidth § 15.323 (c) (7)**Requirement:**

The monitoring system bandwidth must be equal to or greater than the emission bandwidth of the intended transmission and have a maximum reaction time less than $50 \times \text{SQRT}$ (1.25/emission bandwidth in MHz) microseconds for signals at the applicable threshold level but shall not be required to be less than 50 microseconds. If a signal is detected that is 6 dB or more above the applicable threshold level, the maximum reaction time shall be $35 \times \text{SQRT}$ (1.25/emission bandwidth in MHz) microseconds but shall not be required to be less than 35 microseconds.

Measurement Data:

The SN933 WEK-A was tested as per ANSI C63.17-1998 Sections 7.4 and 7.5.

A diagram of the test configuration is enclosed in Appendix A and a list of reference codes for test equipment used is enclosed in Appendix B.

Test equipment used: 22, 6, 23, 24, 25, and 27.

Section 7.4**Simple Compliance Test**

To test for this section two channels were made interference free, the remaining channels had interference so that they were unavailable. The two channels that were interference free were channel 1 (1920.35 MHz) and channel 6 (1922.15 MHz). The frequency of the interfering signal was determined as shown below:

Center frequency of channel 1 = 1920.35 MHz

Emission bandwidth = 295.5 kHz

40% of emission bandwidth = 118.2 kHz

-40% of emission bandwidth = 1920.232 MHz

+40% of emission bandwidth = 1920.468 MHz

+4 dB level above calculated threshold = -83.7 dBm

Step	Test Condition	Result
1	No Interference	Call Established channel 1
2	Sub-band filled with broadband interference (FM modulated) centered at 1920.232 MHz (-40% of emission bandwidth) 4 dB above threshold level	No Call Established on channel 1, call established on channel 6
3	Sub-band filled with broadband interference (CW signal) centered at 1920.232 MHz (-40% of emission bandwidth) 4 dB above threshold level	No Call Established on channel 1, call established on channel 6
4	Sub-band filled with broadband interference (FM modulated) centered at 1920.468 MHz (+40% of emission bandwidth) 4 dB above threshold level	No Call Established on channel 1, call established on channel 6
5	Sub-band filled with broadband interference (CW signal) centered at 1920.468 MHz (+40% of emission bandwidth) 4 dB above threshold level	No Call Established on channel 1, call established on channel 6
6	No Interference	Call Established channel 1

ANSI C63.17 Section 7.5

To test for this section two channels were made interference free, the remaining channels had interference so that they were unavailable. The two channels that were interference free were channel 1 (1920.35 MHz) channel 6 (1922.15 MHz).

Step	Test Condition	Result
1	No Interference	Call Established channel 1
2	Interference on Channel 1 at threshold level, pulse modulated with 102.8 :s pulse width	No Call Established on channel 1, call established on channel 6
3	Interference on Channel 1 6 dB above threshold level, pulse modulated with 72.0 :s pulse width	No Call Established on channel 1, call established on channel 6
4	Interference on Channel 1 10 dB above threshold level, pulse modulated with 154.3 :s pulse width	No Call Established on channel 1, call established on channel 6
5	Step 4 was repeated 5 times with the synchronization of the pulsed interference randomly varied with respect to the EUT frame.	No Call Established on channel 1, call established on channel 6
6	No Interference	Call Established channel 1

SAMPLE CALCULATIONS

$$Pulse\ Width = 35\sqrt{1.25 / B}$$

$$Pulse\ Width = 50\sqrt{1.25 / B}$$

$$Pulse\ Width = 75\sqrt{1.25 / B}$$

Where B = Emission Bandwidth in MHz

$$Pulse\ Width = 35\sqrt{1.25 / 0.2955} = 72.0\ \mu\text{sec}$$

$$Pulse\ Width = 50\sqrt{1.25 / 0.2955} = 102.8\ \mu\text{sec}$$

$$Pulse\ Width = 75\sqrt{1.25 / 0.2955} = 154.3\ \mu\text{sec}$$

RESULT

In the configuration tested, the EUT complied with the requirements of the specification.

3.2.23 Threshold Monitoring Antenna § 15.323 (c) (8)**Requirement:**

The monitoring system shall use the same antenna used for transmission, or an antenna that yields equivalent reception at that location.

Demonstration of Compliance:

The SN933 WEK-A uses the same antenna for both monitoring and for transmission; therefore, the SN933 WEK-A meets the requirements of this section.

3.2.24 Monitoring Detection Threshold for Devices with less than Maximum Output Power § 15.323 (c) (9)**Requirement:**

Devices that have a power output lower than the maximum permitted under the rules may increase their monitoring detection threshold by one decibel for each one decibel that the transmitter power is below the maximum permitted.

Measurement Data:

The SN933 WEK-A does not use the provisions of this section; therefore, the SN933 WEK-A meets the requirements of this section.

3.2.25 Duplex Connections § 15.323 (c) (10)**Requirement:**

An initiating device may attempt to establish a duplex connection by monitoring both its intended transmit and receive time and spectrum windows. If both the intended transmit and receive time and spectrum windows meet the access criteria, then the initiating device can initiate a transmission in the intended

transmit time and spectrum window. If the power detected by the responding device can be decoded as a duplex connection signal from the initiating device, then the responding device may immediately begin transmitting on the receive time and spectrum window monitored by the initiating device.

Measurement Data:

The SN933 WEK-A was tested as per ANSI C63.17-1998 Section 8.2.3.

A diagram of the test configuration is enclosed in Appendix A and a list of reference codes for test equipment used is enclosed in Appendix B.

Test equipment used: 22, 6, 23, 24, 25, and 32.

Section 8.2.3

The ZT (base station) is the initiating device and monitors the receive and transmit windows for both the ZT and PS (handset). The ZT was configured with a custom test fixture which allows interference on all of the time slots except for one TX slot and RX slot. These can be a duplex pair (TX slot 3, RX slot 3) or different slots (TX slot 3, RX slot 4).

To test for this section two channels were made interference free, the remaining channels had interference so that they were unavailable. The two channels that were interference free were channel 1 (1920.35 MHz) channel 6 (1922.15 MHz). The interference on the specified time slots were placed on channel 1 with channel 6 interference free.

Step	Test Condition	Result
1	No Interference	Call Established channel 1
2	Interference on all time slots except slot 2 RX was interference free	No Call Established on channel 1, call established on channel 6
3	Interference on all time slots except slot 2 TX was interference free	No Call Established on channel 1, call established on channel 6
4	Interference on all time slots except slot 3 TX and slot 2 RX were interference free	No Call Established on channel 1, call established on channel 6

Step	Test Condition	Result
5	Interference on all time slots except slot 2 TX and slot 3 RX were interference free	No Call Established on channel 1, call established on channel 6
6	Interference on all time slots except slot 3 TX and slot 3 RX were interference free	Call Established channel 1
7	No Interference	Call Established channel 1

RESULT

In the configuration tested, the EUT complied with the requirements of the specification.

3.2.26 Alternative Monitoring Interval § 15.323 (c) (11)**Requirement:**

An initiating device that is prevented from monitoring during its intended transmit window due to monitoring system blocking from the transmissions of a co-located (within one meter) transmitter of the same system, may monitor the portions of the time and spectrum windows in which they intend to receive over a period of at least 10 milliseconds. The monitored time and spectrum window must total at least 50 percent of the 10 millisecond frame interval and the monitored spectrum must be within the 1.25 MHz frequency channel(s) already occupied by that device or co-located co-operating devices. If the access criteria is met for the intended receive time and spectrum window under the above conditions, then transmission in the intended transmit window by the initiating device may commence.

Demonstration of Compliance:

The SN933 WEK-A will not be co-located closer than 1 meter; therefore, the requirements of this section do not apply. This requirement is specified in the Installation Manual.

**3.2.27 Limitation on use of Section (c) (10) or (c) (11) -
§15.323 (c) (12)****Requirement:**

The provisions of (c) (10) or (c) (11) of this section shall not be used to extend the range of spectrum occupied over space or time for the purpose of denying fair access to spectrum to other devices.

Demonstration of Compliance:

The SN933 WEK-A does not use the provisions of § 15.323 (c) (10) or (c) (11) to extend the range of spectrum occupied; therefore, the PS3D meets the requirements of this section.

3.2.28 Spurious Emissions § 15.323 (d)**Requirement:**

Emissions shall be attenuated below a reference power of 112 milliwatts as follows: 30 dB between the channel edges and 1.25 MHz above or below the channel; 50 dB between 1.25 and 2.5 MHz above or below the channel; And 60 dB at 2.5 MHz or greater above or below the channel. Systems that further sub-divide a 1.25 MHz channel into X sub-channels must comply with the following emission mask: In the bands between 1B and 2B measured from the center of the emission bandwidth the total power emitted by the device shall be at least 30 dB below the transmit power permitted for that device; in the bands between 2B and 3B measured from the center of the emission bandwidth the total power emitted by an intentional radiator shall be at least 50 dB below the transmit power permitted for that radiator; in the bands between 3B and 1.25 MHz channel edge the total power emitted by an intentional radiator in the measurement bandwidth shall be at least 60 dB below the transmit power permitted for that radiator. "B" is defined as the emission bandwidth of the device in hertz. Compliance with the emission limits is based on the use of measurement instrumentation employing a peak detector function with an instrument resolution bandwidth approximately equal to 1.0 percent of the emission bandwidth of the device under measurement.

Measurement Data:

The PS3D was tested as per ANSI C63.17-1998 Section 6.1.6.

A diagram of the test configuration is enclosed in Appendix A and a list of reference codes for test equipment used is enclosed in Appendix B.

Test equipment used: 1 and 17.

The PS3D tunes up to 1930 MHz; therefore, in accordance with § 15.33 (b) (1), the EUT was tested from 30 MHz to 20 GHz, and in accordance with § 15.31 (m) the EUT was tested with the transmitter tuned near the bottom of the spectrum and tuned near the top of the spectrum.

Out-of-Channel Emission (Conducted)

Transmitting on Channel 1 (1920.35 MHz)			
Frequency Range MHz	Frequency MHz	Corrected Level dBm	Criteria dBm
30 -200	82.9	-91.9	-39.5
200 - 500	228.2	-91.4	-39.5
500 - 1000	720.5	-91.8	-39.5
1000 - 1800	1686.4	-73.6	-39.5
1800 - 1900	1897.5	-90.9	-39.5
1900 - 1917.50	1903.8	-91.8	-39.5
1917.50 -1918.75	1918.1	-91.4	-29.5
1918.75 - 1920	1918.9	-83.4	-9.5
1921.25 - 1922.5	1921.3	-91.3	-9.5
1922.5 - 1923.75	1923.6	-91.7	-29.5
1923.75 - 1930	1928.5	-91.3	-39.5
1930 - 2000	1956.5	-91.7	-39.5
2000 - 4000	3836.0	-43.9	-39.5
4000 - 6000	5840.0	-61.2	-39.5
6000 - 8000	6654.0	-58.3	-39.5
8000 - 19300	18940	-51.9	-39.5
* Noise Floor			

Transmitting on Channel 20 (1929.65MHz)			
Frequency Range MHz	Frequency MHz	Corrected Level dBm	Criteria dBm
30 -200	119.1	-56.7	-39.5
200 - 500	476.0	-69.8	-39.5
500 - 1000	802.0	-45.6	-39.5
1000 - 1800	1695.2	-68.4	-39.5
1800 - 1900	1865.3	-77.3	-39.5
1900 - 1920	1920.0	-77.6	-39.5
1920 - 1926.25	1924.7	-75.8	-39.5
1926.25 - 1927.5	1926.4	-74.3	-29.5
1927.5 - 1928.75	1928.7	-72.9	-9.5
1930 - 1931.25	1930.0	-59.6	-9.5
1931.25 - 1932.5	1931.5	-73.0	-29.5
1932.5 - 2000	1993.8	-69.4	-39.5
2000 - 4000	3858.0	-45.9	-39.5
4000 - 6000	5054.0	-77.1	-39.5
6000 - 8000	6664.0	-83.4	-39.5
8000 - 19300	18700.0	-71.4	-39.5
* Noise Floor			

Out-of-Subchannel Emission (Conducted)

Transmitting on Channel 1 (1920.35 MHz)				
	Frequency Range MHz	Frequency MHz	Corrected Level dBm	Criteria dBm
1B to 2B Above	1920.649 - 1920.941	1920.650	-31.9	-12.7
2B to 3B Above	1920.941 - 1921.237	1920.961	-52.5	-32.7
3B to Channel Edge	1921.237 - 1921.250	1921.242	-53.2	-42.7

Transmitting on Channel 3 (1920.95 MHz)				
	Frequency Range MHz	Frequency MHz	Corrected Level DBm	Criteria dBm
1B to 2B Below	1920.359 - 1920.655	1920.654	-33.8	-12.7
2B to 3B Below	1920.064 - 1920.359	1920.310	-53.5	-32.7
3B to Channel Edge	1920.000 - 1920.064	1920.062	-54.8	-42.7

Transmitting on Channel 18 (1929.05 MHz)				
	Frequency Range MHz	Frequency MHz	Corrected Level dBm	Criteria dBm
1B to 2B Above	1929.346 - 1929.641	1929.346	-36.5	-12.7
2B to 3B Above	1929.641 - 1929.937	1929.665	-52.1	-32.7
3B to Channel Edge	1929.937 - 1930.000	1929.986	-54.6	-42.7

Transmitting on Channel 20 (1929.65 MHz)				
	Frequency Range MHz	Frequency MHz	Corrected Level dBm	Criteria dBm
1B to 2B Below	1929.059 - 1929.355	1929.352	-34.4	-12.7
2B to 3B Below	1928.764 - 1929.059	1929.059	-53.8	-32.7
3B to Channel Edge	1928.750 - 1928.764	1928.754	-54.0	-42.7

Out-of-UPCS Band Emissions (Radiated)

The conducted emissions method was used to determine compliance.

RESULT

In the configuration tested, the EUT complied with the requirements of the specification.

3.2.29 Frame Repetition Stability/Frame Period and Jitter § 15.323 (e)

Requirement:

The frame period (a set of consecutive time slots in which the position of each time slot can be identified by reference to a synchronizing source) of an intentional radiator operating in these sub-bands shall be 20 milliseconds or 10 milliseconds/X where X is a positive whole number. Each device that implements time division for the purposes of maintaining a duplex connection on a given frequency carrier shall maintain a frame repetition rate with a frequency stability of at least 50 parts per million (ppm). Each device which further divides access in time in order to support multiple communication links on a given frequency carrier shall maintain a frame repetition rate with a frequency stability of at least 10 ppm. The jitter (time-related, abrupt, spurious variations in the duration of the frame interval) introduced at the two ends of such a communication link shall not exceed 25 microseconds for any two consecutive transmissions. Transmissions shall be continuous in every time and spectrum

window during the frame period defined for the device.

Measurement Data:

The PS3D was tested in accordance with ANSI C63.17-1998 Sections 6.2.3 and 6.2.4.

A diagram of the test configuration is enclosed in Appendix A and a list of reference codes for test equipment used is enclosed in Appendix B.

Test equipment used: 10.

Test Performed	Criteria
Frame period	5 msec
Frame repetition stability	10 ppm
Jitter	12.5 μ sec

Section 6.2.3

The PS3D was configured as specified in section 6.2.3. Both the mean values of the frame repetition rate and the standard deviation were recorded to determine the frame repetition stability. The data is shown below.

5 msec Frame Rate

Frequency MHz	Standard Deviation Hz	Mean Hz	Frame Repetition Stability ppm
1920.35	0.00012289	200.0000486	1.84

Sample Calculation:

Frame Repetition Stability (ppm) = $((3 * \text{Standard Deviation}) / \text{Frame Rate}) * 10^6$

Frame Rate Hz = $1 / 5 \text{ ms} = 200 \text{ Hz}$

Section 6.2.4

The PS3D was configured as specified in section 6.2.4. The peak to peak, mean and standard deviation values of the frame period distribution were recorded to determine the frame period and

jitter.

The mean value shall be the frame period and three times the standard deviation value of the jitter shall not be greater than 12.5 μ sec. The data is shown below.

5 msec Frame Rate

Frequency MHz	Standard Deviation μ sec	Mean ms	Jitter μ sec
1920.35	0.3091581	4.99933162429	0.93

Sample Calculation:

Jitter μ sec = 3 * Standard Deviation

RESULT

In the configuration tested, the EUT complied with the requirements of the specification.

3.2.30 Frequency Stability § 15.323 (f)

Requirement:

The frequency stability of the carrier frequency of the intentional radiator shall be maintained within ± 10 ppm over 1 hour or the interval between channel access monitoring, whichever is shorter. The frequency stability shall be maintained over a temperature variation of -20° to $+50^{\circ}$ C at normal supply voltage, and over a variation in the primary supply voltage of 85 percent to 115 percent of the rated supply voltage at a temperature of 20° C. For equipment that is capable only of operating from a battery, the frequency stability tests shall be performed using a new battery without any further requirement to vary supply voltage.

Measurement Data:

The PS3D was tested as per ANSI C63.17-1998 Section 6.2.2.

A diagram of the test configuration is enclosed in Appendix A and a list of reference codes for test equipment used is

enclosed in Appendix B.

Test equipment used: 10 and 14.

The carrier frequency measurement at 20⁰ C was used as the reference for the measurements at the two extreme temperatures.

The carrier frequency measurement at 20⁰ C was used as the reference for the measurements at the two extreme temperatures. The manufacture has declared that the lower temperature extreme that the unit is designed to operate is -10⁰ C.

Temp C ^o	Supply Voltage	Frequency of Carrier MHz	Measured Frequency MHz	Deviation ppm
-10	Nominal	1920.35	1920.35494978	-1.67
20	Nominal (3.6 VDC)	1920.35	1920.35815848	Reference
50	Nominal	1920.35	1920.35202415	-3.19

SAMPLE CALCULATION

$$\text{Deviation ppm} = \frac{FR - FM}{FR} \times 10^6$$

FR = Reference frequency of the carrier at 20⁰ C

FM = Measured frequency of the carrier

RESULT

In the configuration tested, the EUT complied with the requirements of the specification.

Appendix A - Test Procedures

FCC Section 15.309 Cross Reference to Subpart B (Radiated Emissions)

The radiated emissions were tested as per ANSI C63.4.

The radiated emissions from the PS3D were measured using a spectrum analyzer with a quasi-peak adapter for peak and quasi-peak readings. A preamplifier with a fixed gain of 26 dB was used to increase the sensitivity of the measuring instrumentation. The spectrum analyzer's resolution bandwidth was set to 100 kHz and the video bandwidth was set to 300 kHz, for readings in the 30 to 1000 MHz frequency range. Above 1000 MHz the spectrum analyzer's resolution bandwidth was set to 1 MHz and the video bandwidth was set to 3 MHz for peak readings and the resolution bandwidth was set to 1 MHz and the video bandwidth was set to 10 Hz for average readings.

An EMCO Biconical antenna was used to measure the frequency range of 30 to 200 MHz, an EMCO Log Periodic antenna was used to measure the frequency range of 200 to 1000 MHz and a double ridge guide antenna was used to measure the frequency range of 1 to 20 GHz, at a distance of 3 meters from the EUT. The readings obtained by these antennas are correlated to the levels obtained with a tuned dipole antenna by adding the antenna factors.

The configuration of the PS3D was varied to find the maximum radiated emission. All interconnecting cables were moved to search for the worst case radiated emissions. The computing equipment was rotated 360 degrees, and the antenna height was varied from 1 to 4 meters to find the maximum radiated emission.

The PS3D was measured on a non-conducting table 0.8 m above the ground plane. The table is placed on a turntable which is level with the ground plane. The turntable has slip rings, which supply AC power to the computing equipment.

R a d i a t e d E m i s s i o n s T e s t

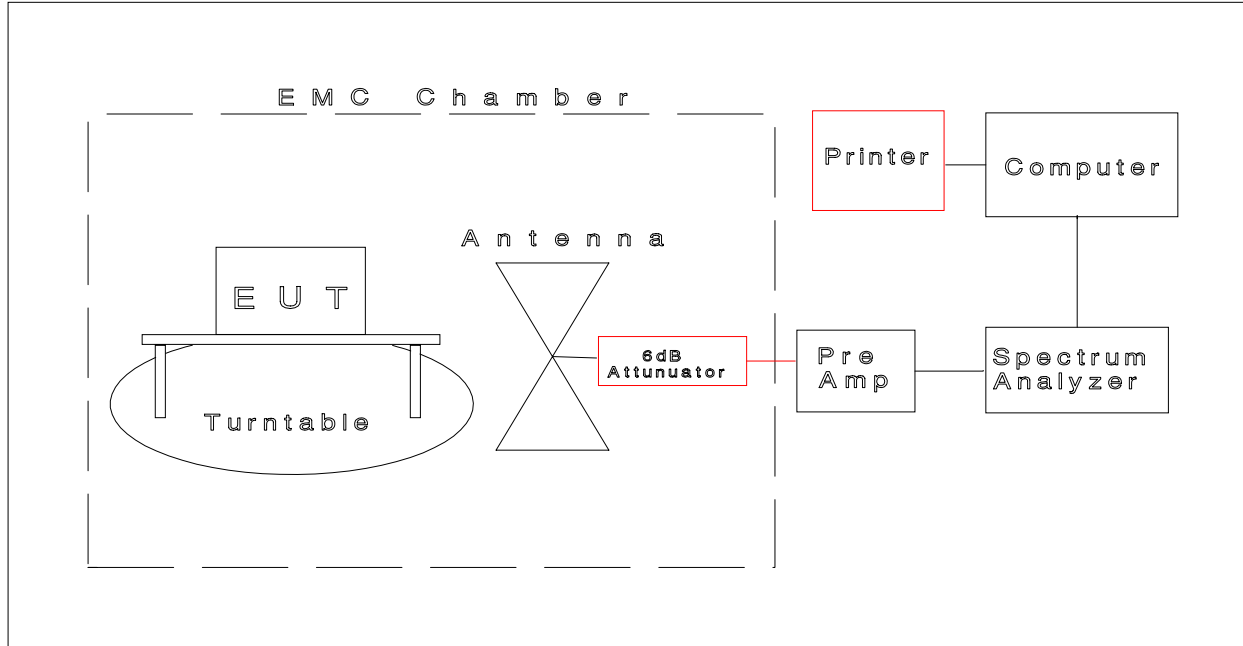
**FCC Section 15.315 AC Power Line Conducted Emissions**

The AC power line conducted emissions were tested as per ANSI C63.4.

The AC power line conducted emissions was measured using a spectrum analyzer with a quasi-peak adapter for quasi-peak readings. The spectrum analyzer's resolution bandwidth was set to 100 kHz, and the video bandwidth was set to 300 kHz for peak readings in the 450 kHz to 30 MHz frequency range.

The line-conducted measurements were made in a screen room using a 50 μ H Line Impedance Stabilization Network (LISN).

Desktop computing devices are placed on a non-conducting table 80-cm from the metallic floor. The equipment is placed 40 cm from one wall and at least 80 cm from all other walls. Floor standing equipment is placed directly on the earth grounded floor.

Line Conducted Emissions Test

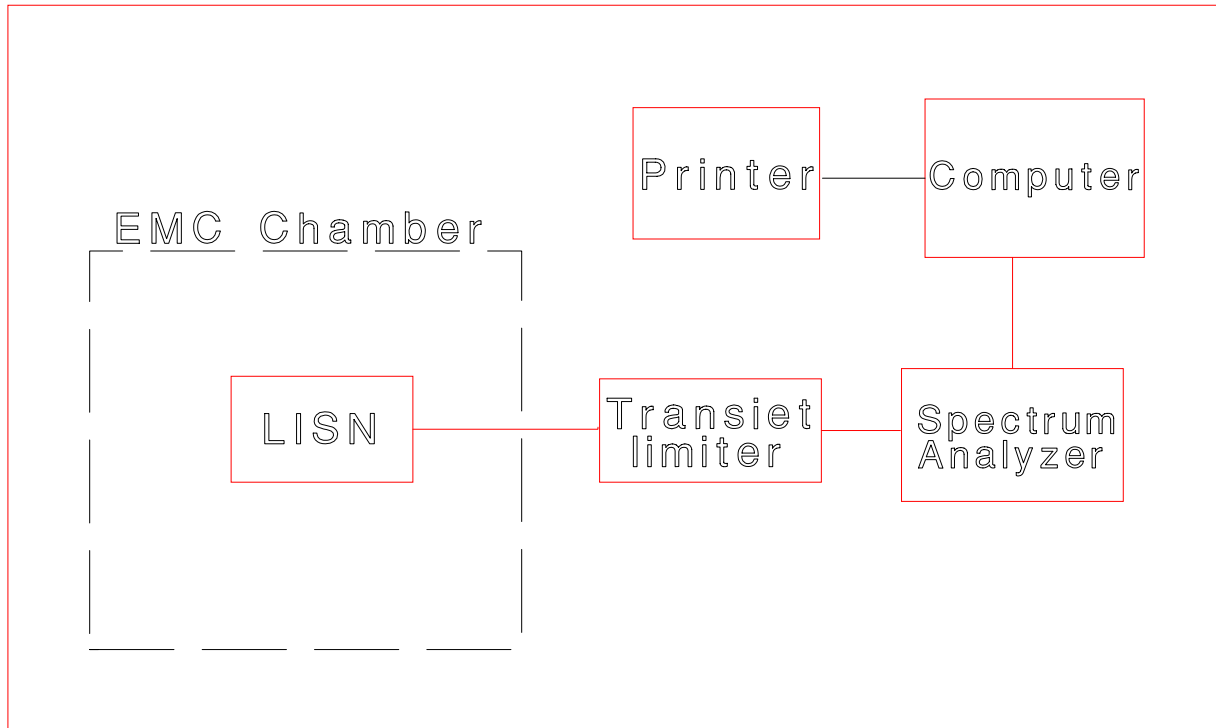

FCC Sections 15.319 (c) Peak Transmit Power, 15.319 (d) Power Spectral Density

The EUT was directly connected to the spectrum analyzer via the antenna output port as shown in the block diagram below. The peak transmit power, emission bandwidth and power spectral density were measured as per sections 6.1.2, 6.1.3 and 6.1.5 of ANSI C63.17-1998, while the base station and handset had a voice link established. The measurements were performed on two channels, as per 47 CFR 15.31(m), one near the bottom of the spectrum and one near the top of the spectrum.

The spectrum analyzer's resolution bandwidth and video bandwidth were set as follows:

Peak Transmit Power (Section 6.1.2)

RBW = 1 MHz

VBW = 3 MHz

Emission Bandwidth (Section 6.1.3)

RBW = 3 kHz
VBW = 10 kHz

Power Spectral Density (Section 6.1.5)

RBW = 3 kHz
VBW = 10 kHz

**Test Configuration Block Diagram
(Sections 6.1.2, 6.1.3 and 6.1.5)**

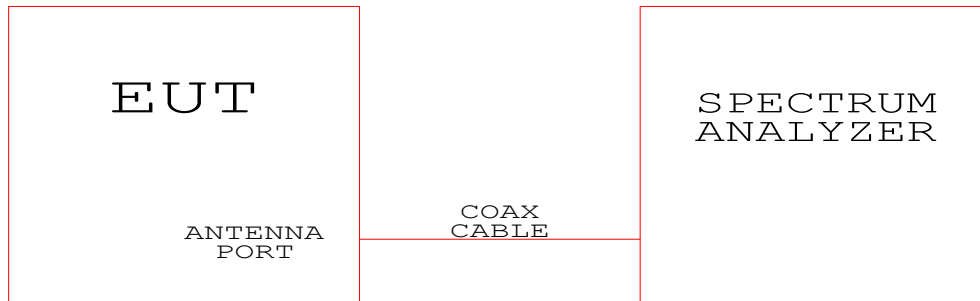

**FCC Sections 15.323 (b), 15.323 (c) (1) through 15.323 (c) (12) -
Sections 7 and 8 of ANSI C63.17-1998**

The EUT connected as shown in the block diagrams below. The MCSS was used to force the EUT to transmit on the desired frequencies and block all the other frequencies. The testing was performed as per sections 7 and 8 of ANSI C63.17-1998, while the base station and handset had a voice link established

**Test Configuration Block Diagram
(Sections 8.1.2, 8.1.3 and 8.2.1)**

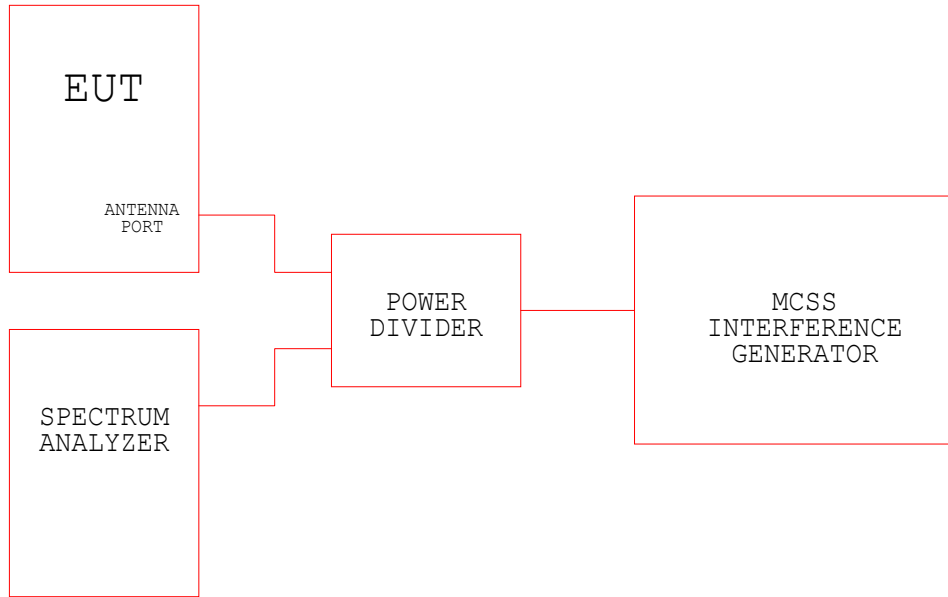

**Test Configuration Block Diagram
(Sections 7.3.2.1, 7.3.2.2 and 7.4)**

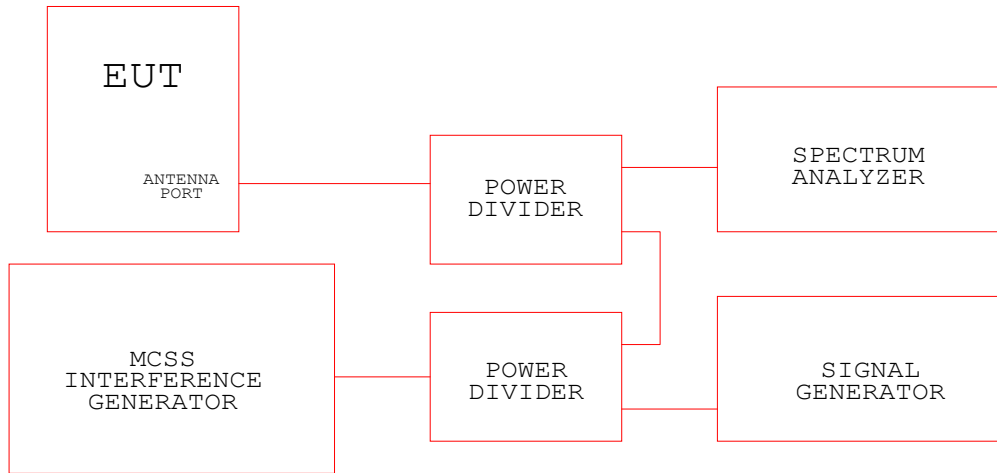

**Test Configuration Block Diagram
(Section 7.5)**

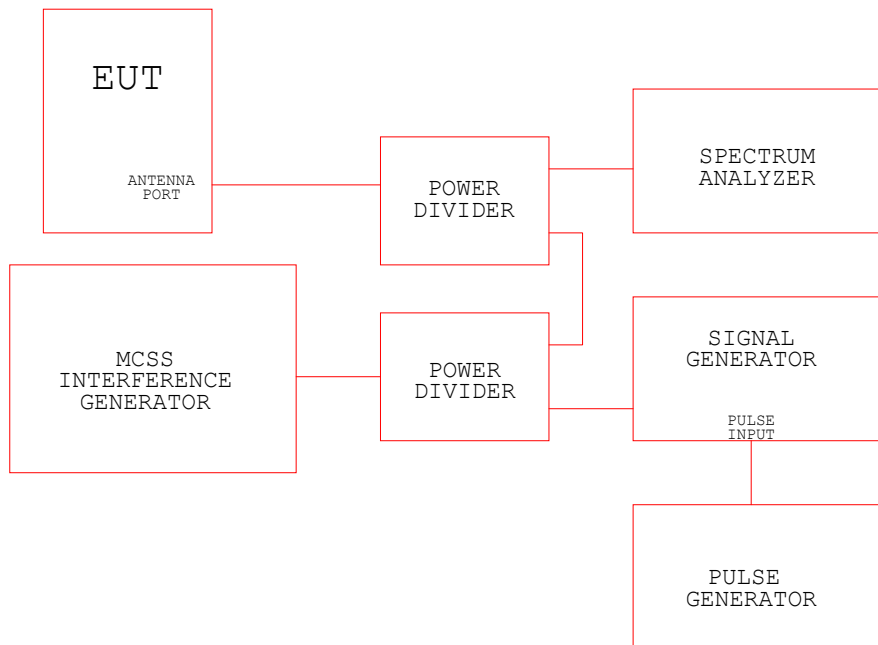

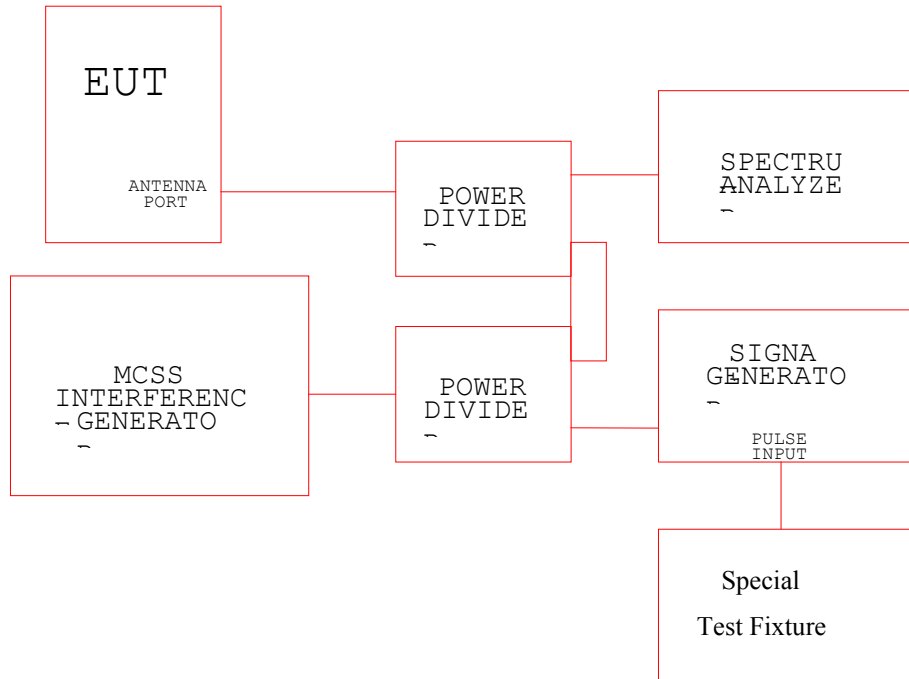
**Test Configuration Block Diagram
(Section 8.2.3)****FCC Section 15.323 (d) Spurious Emissions**

The EUT was directly connected to the spectrum analyzer via the antenna output port as shown in the block diagram below. The base station was connected to a computer that was used to control the base station to permit the base station and handset to transmit on predetermined channels. The spurious emissions were measured as per section 6.1.6 of ANSI C63.17-1998, while the base station and handset had a voice link established. The out-of-channel measurements were performed on two channels, as per 47 CFR 15.31(m), one near the bottom of the spectrum and one near the top of the spectrum. The out-of-subchannel measurements were performed on two sub-channels, one near the bottom of the subchannel and one near the top of the sub-channel.

The spectrum analyzer's resolution bandwidth and video bandwidth were set as follows:

Spurious Emissions (Section 6.1.6)

RBW = 3 kHz
VBW = 10 kHz

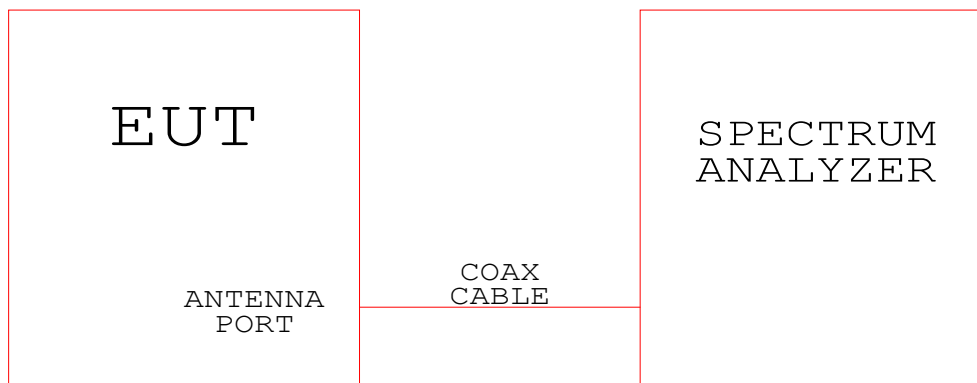
**Test Configuration Block Diagram
(Section 6.1.6)****FCC Section 15.323 (e) Frame Period**

The EUT was directly connected to the modulation domain analyzer via the antenna output port as shown in the block diagram below. The base station was connected to a computer that was used to control the base station to permit the base station and handset to transmit on predetermined channels. The frame period, frame repetition stability and jitter were measured as per sections 6.2.3 and 6.2. of ANSI C63.17-1998, while the base station and handset had a voice link established. The computer was used to log the results of the measurements.

Frame related measurements were allowed by the utilization of the modulation domain analyzer's "Envelope Trigger Output" port, which generates a TTL compatible signal that represents the envelope of the transmission bursts.

The modulation domain analyzer's settings were set as follows:

Frame Repetition Stability

Mode:	Frequency Measurement
X Axis:	Time
Time Setting:	500 ms
Y Axis:	Frequency
Center Frequency:	200 Hz
Measurement Interval:	5 ms
No. of Measurements:	1000

Frame Period and Jitter

Mode:	Time Measurement
Y Axis:	Time
Center Time:	5 ms
X Axis:	Time
Time Setting:	500 ms
Measurement Interval:	1 ms
No. of Measurements:	1,000,000

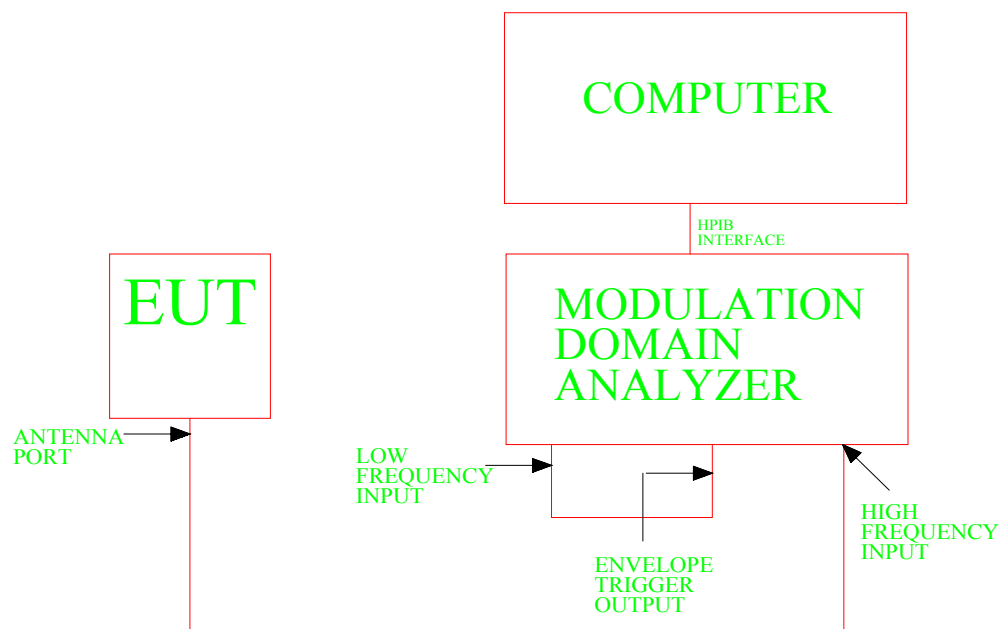
**FCC Section 15.323 (f) Carrier Frequency Stability**

The EUT was placed inside of a temperature chamber and directly connected to the modulation domain analyzer via the antenna output port as shown in the block diagram below. The base station was connected to a computer that was used to control the base station to permit the base station and handset to transmit on predetermined channels. The carrier frequency stability was measured as per section 6.2.2 of ANSI C63.17-1998, while the base station and handset had a voice link established. The computer was used to log the results of the measurements.

The EUT was placed inside of the temperature chamber at 20°C for one hour in order to stabilize the temperature of the chamber and the EUT. This measurement was recorded as a reference for

the measurements at the two extreme temperatures and at the two extreme supply voltages using the modulation domain analyzer.

The modulation domain analyzer settings were set as follows:

Carrier Frequency Stability

Mode:	Frequency Measurement
Y Axis:	Frequency
Center Frequency:	1920.35 MHz
X Axis:	Time
Time Setting:	625 us
Measurement Interval:	10 us
No. of Measurements:	5000

Test Configuration Block Diagram (Section 6.2.2)

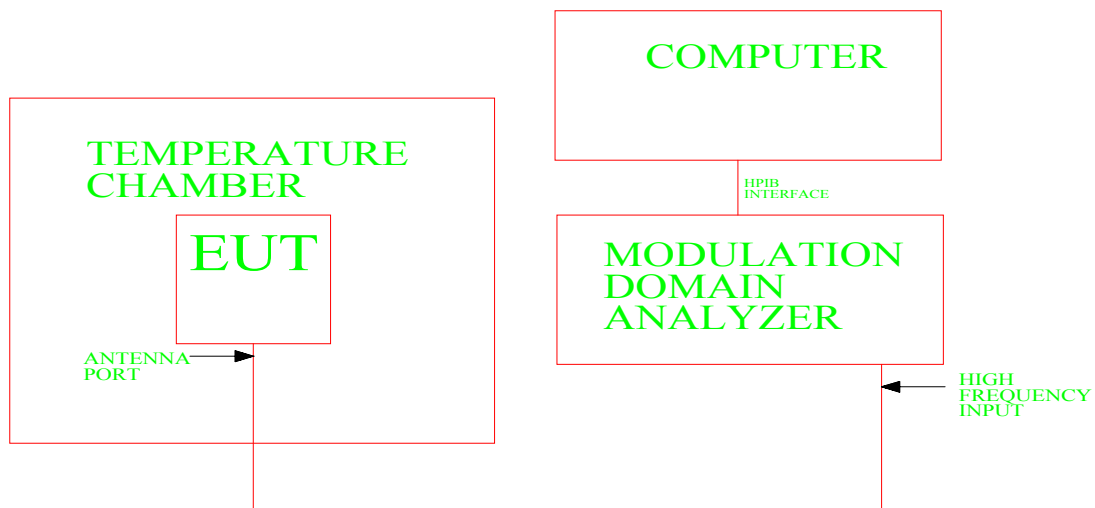

Appendix B - List of Test Equipment

Ref. No.	Instrument	Mfgt.	Model
1	Spectrum Analyzer	Hewlett Packard	8566B
2	Pre Amplifier	Hewlett Packard	8447D
3	Pre Amplifier	Hewlett Packard	8449B
4	Biconilog Antenna	EMCO	3142
5	Double Ridge Guide Antenna	EMCO	3115
6	Power Divider/Combiner	Hewlett Packard	11636A
7	Power Divider/Combiner	Hewlett Packard	87303C
8	Signal Generator	Hewlett Packard	8648C
9	MCSS	Hewlett Packard	60
10	Modulation Domain Analyzer	Hewlett Packard	53310A
11	Pulse Generator	Hewlett Packard	8012B
12	LISN	EMCO	3825/2
13	Transient Limiter	Hewlett Packard	11947A
14	Temperature Chamber	Tenney Inc.	Tenney Jr.
15	Oscilloscope	Tektronix	7603
16	Test Fixture	NEC America, Inc.	N/A
17	Coax Cable	Andrews	N/A
18	Spectrum Analyzer	Advantest	R3261
19	RFI/Field Intensity Meter	Kyoritusu Corp.	KNM-5002
20	Frequency Converter	Kyoritusu Corp.	KCV-6002
21	Pre Amplifier	Hewlett Packard	8449B
22	Spectrum Analyzer	Hewlett Packard	8563E
23	Power Divider/Combiner	Tamagawa Electronics Co., Ltd.	UPD-2

24	Signal Generator	Hewlett Packard	8643A
25	MCSS	Hewlett Packard	8648C
26	Pulse Generator	Hewlett Packard	3312A
27	LISN	Kyoritsu Electrical Works, Ltd.	KNW-407
28	Spectrum Analyzer	Advantest	TR4135
29	RFI/Field Intensity Meter	Kyoritsu Electrical Works, Ltd.	KNM-2402
30	Plotter	Hewlett Packard	7470A
31	Protocol Analyzer	Advantest	D5111B
32	NEC Test Fixture	NEC	N/A

An independent calibration laboratory following outlined calibration procedures calibrates all the equipment listed above every 12 months.