



FCC TEST REPORT (FOR RFID)

REPORT NO.: RF110923D14-1
MODEL NO.: M8935
FCC ID: AVHM8935
RECEIVED: Sep. 23, 2011
TESTED: Dec. 13 ~ 22, 2011
ISSUED: Dec. 27, 2011

APPLICANT: ParTech, Inc.

ADDRESS: 8383 Seneca Turnpike, New Hartford, New York
13413-4991 USA

ISSUED BY: Bureau Veritas Consumer Products Services
(H.K.) Ltd., Taoyuan Branch

LAB ADDRESS: No. 47, 14th Ling, Chia Pau Vil., Lin Kou Dist.,
New Taipei City, Taiwan (R.O.C)

This test report consists of 34 pages in total. It may be duplicated completely for legal use with the approval of the applicant. It should not be reproduced except in full, without the written approval of our laboratory. The client should not use it to claim product endorsement by TAF or any government agencies. The test results in the report only apply to the tested sample.





Table of Contents

RELEASE CONTROL RECORD	3
1 CERTIFICATION	4
2 SUMMARY OF TEST RESULTS	5
2.1 MEASUREMENT UNCERTAINTY	5
3 GENERAL INFORMATION	6
3.1 GENERAL DESCRIPTION OF EUT	6
3.1 DESCRIPTION OF TEST MODES	7
3.1.1 CONFIGURATION OF SYSTEM UNDER TEST	8
3.1.2 TEST MODE APPLICABILITY AND TESTED CHANNEL DETAIL:	9
3.2 GENERAL DESCRIPTION OF APPLIED STANDARDS	11
3.3 DESCRIPTION OF SUPPORT UNITS	11
4 TEST PROCEDURE AND RESULT	12
4.1 CONDUCTED EMISSION MEASUREMENT	12
4.1.1 LIMITS OF CONDUCTED EMISSION MEASUREMENT	12
4.1.2 TEST INSTRUMENTS	12
4.1.3 TEST PROCEDURES	13
4.1.4 DEVIATION FROM TEST STANDARD	13
4.1.5 TEST SETUP	14
4.1.6 EUT OPERATING CONDITIONS	14
4.1.7 TEST RESULTS	15
4.2 RADIATED EMISSION MEASUREMENT	19
4.2.1 LIMITS OF RADIATED EMISSION MEASUREMENT	19
4.2.2 TEST INSTRUMENT	20
4.2.3 TEST PROCEDURE	21
4.2.4 DEVIATION FROM TEST STANDARD	21
4.2.5 TEST SETUP	22
4.2.6 EUT OPERATING CONDITION	22
4.2.7 TEST RESULT	23
4.3 FREQUENCY STABILITY	28
4.3.1 LIMITS OF FREQUENCY STABILITY MEASUREMENT	28
4.3.2 TEST INSTRUMENTS	28
4.3.3 TEST PROCEDURE	28
4.3.4 DEVIATION FROM TEST STANDARD	28
4.3.5 TEST SETUP	29
4.3.6 EUT OPERATING CONDITION	29
4.3.7 TEST RESULTS	30
5 PHOTOGRAPHS OF THE TEST CONFIGURATION	32
6 INFORMATION ON THE TESTING LABORATORIES	33
7 APPENDIX A – MODIFICATIONS RECORDERS FOR ENGINEERING CHANGES TO THE EUT BY THE LAB	34



A D T

RELEASE CONTROL RECORD

ISSUE NO.	REASON FOR CHANGE	DATE ISSUED
RF110923D14-1	Original release	Dec. 27, 2011



1 CERTIFICATION

PRODUCT: Temperature Measuring Device
BRAND NAME: Par
MODEL NO: M8935
APPLICANT: ParTech, Inc.
TESTED: Dec. 13 ~ 22, 2011
TEST SAMPLE: ENGINEERING SAMPLE
STANDARDS: FCC Part 15, Subpart C (Section 15.225)
ANSI C63.4-2003
ANSI C63.10-2009

The above equipment has been tested by **Bureau Veritas Consumer Products Services (H.K.) Ltd., Taoyuan Branch**, and found compliance with the requirement of the above standards. The test record, data evaluation & Equipment Under Test (EUT) configurations represented herein are true and accurate accounts of the measurements of the sample's EMC characteristics under the conditions specified in this report.

PREPARED BY : Annie Chang , **DATE:** Dec. 27, 2011
(Annie Chang / Senior Specialist)

APPROVED BY : Ken Liu , **DATE:** Dec. 27, 2011
(Ken Liu / Manager)

2 SUMMARY OF TEST RESULTS

The EUT has been tested according to the following specifications:

APPLIED STANDARD: FCC PART 15, SUBPART C (SECTION 15.225)			
STANDARD SECTION	TEST TYPE AND LIMIT	RESULT	REMARK
15.207	AC Power Conducted Emission	PASS	Meet the requirement of limit. Minimum passing margin is -0.85dB at 13.559MHz
15.225(a)	Field Strength	PASS	Meet the requirement of limit. Minimum passing margin is -72.6dB at 13.56MHz
15.225(d)	Radiated Emission	PASS	Meet the requirement of limit. Minimum passing margin is -1.9dB at 76.81MHz
15.225(e)	Frequency Stability	PASS	Meet the requirement of limit.

2.1 MEASUREMENT UNCERTAINTY

Where relevant, the following measurement uncertainty levels have been estimated for tests performed on the EUT as specified in CISPR 16-4-2:

This uncertainty represents an expanded uncertainty expressed at approximately the 95% confidence level using a coverage factor of $k=2$.

Measurement	Uncertainty
Conducted emissions	2.41 dB
Radiated emissions	3.87 dB

3 GENERAL INFORMATION

3.1 GENERAL DESCRIPTION OF EUT

PRODUCT	Temperature Measuring Device
MODEL NO.	M8935
FCC ID	AVHM8935
POWER SUPPLY	DC 3.7V (from battery) or DC 5V (from AC Adapter or host equipment)
MODULATION TYPE	ASK
OPERATING FREQUENCY	13.56MHz
NUMBER OF CHANNEL	1
ANTENNA TYPE	FR4 Single-Band Antenna
ANTENNA CONNECTOR	N/A
DATA CABLE	Shielded USB cable (1.5 m)
I/O PORTS	Refer to user's manual
ASSOCIATED DEVICES	N/A

NOTE:

1. The EUT is a Temperature Measuring Device. The functions of EUT listed as below:

FUNCTION	TEST STANDARD	REFERENCE REPORT
Bluetooth Module (Brand: Panasonic, Model: PAN1315 and PAN1325)	FCC Part 15, Subpart C (Section 15.247)	RF110923D14
RFID (Brand: TI, Model: TRF7960RHBT)	FCC Part 15, Subpart C (Section 15.225)	RF110923D14-1

The Bluetooth module itself without antenna is designated PAN1315. The antenna module with mounted antenna is designated PAN1325.

2. The EUT consumes power from an AC adapter, cradle or battery, as follows:

Item	Brand	Model No.	Spec.
Adapter	Elementech Internrtional Co., Ltd.	AU1050501z (z=e,u,b,s,c,k,0)	AC I/P: 100-240V, 50/60Hz, 0.2A DC O/P: 5V, 1A AC 2-Pin (Fixed plug) Shielded USB cable (1.5 m)
		AU10505040	AC I/P: 100-240V, 50/60Hz, 0.2A DC O/P: 5V, 1A AC 2-Pin (Detachable plug) Shielded USB cable (1.5 m)
Cradle	Par	K8935	DC 5V from Adapter
Battery	iEi	MODAT-300	3.7Vdc, 1880mAh, 7Wh

The above adapters are identical to each except for the AC plug type only, therefore, only **model: AU1050501u** was selected for the final test.

3. For Conducted & Radiated Emissions tests, following modes were pre-tested:

- u EUT + Cradle link to Notebook PC
- u EUT link to Notebook PC
- u EUT + Cradle + Adapter
- u EUT + Adapter
- u EUT only (Radiated only)

The worst emission level was found when the EUT was tested under **EUT + Cradle link to Notebook PC** mode, therefore, only its test data was recorded in this report.

4. For a more detailed features description, please refer to the manufacturer's specifications or the User's Manual.

3.1 DESCRIPTION OF TEST MODES

1 channel was provided to this EUT.

Channel	FREQUENCY (MHz)
1	13.56

3.1.1 CONFIGURATION OF SYSTEM UNDER TEST

Mode A:

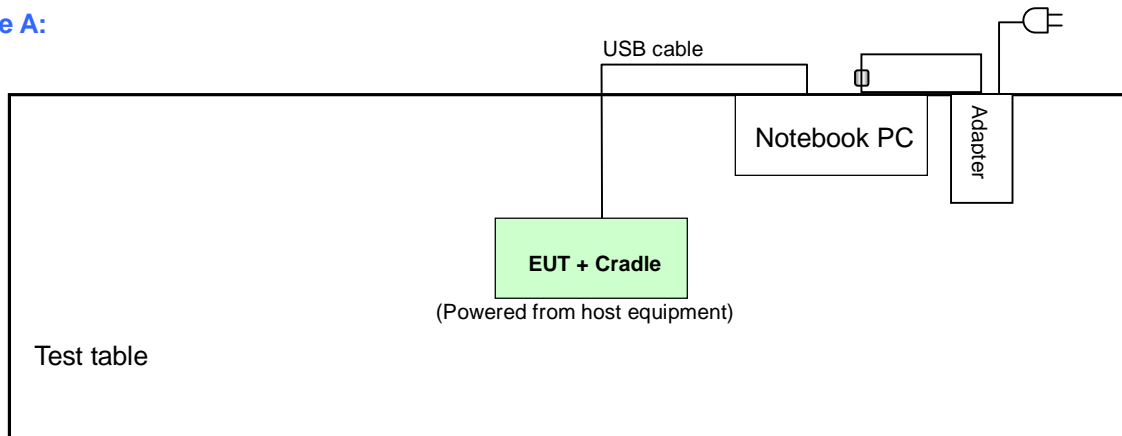

Mode B:

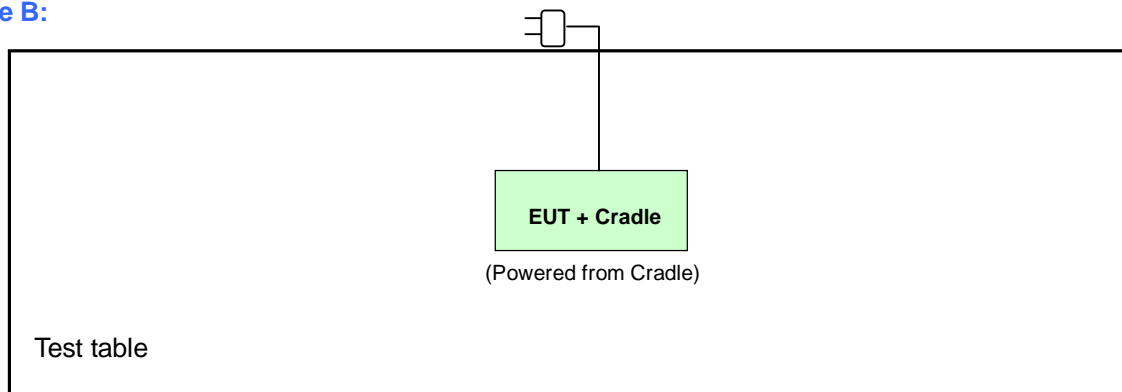

Mode C:

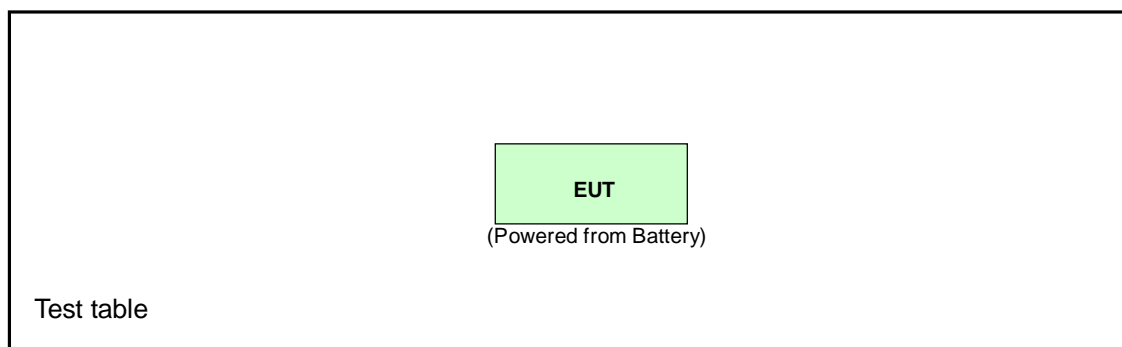

3.1.2 TEST MODE APPLICABILITY AND TESTED CHANNEL DETAIL:

EUT CONFIGURE MODE	APPLICABLE TO			DESCRIPTION
	PLC	RE	FS	
A	√	√	√	EUT + Cradle link to Notebook PC
B	√	-	√	EUT + Cradle + Adapter
C	-	-	√	EUT only

Where **PLC**: Power Line Conducted Emission
RE: Radiated Emission
FS: Frequency Stability

POWER LINE CONDUCTED EMISSION TEST:

- Pre-Scan has been conducted to determine the worst-case mode from all possible combinations between available modulations, data rates and antenna ports (if EUT with antenna diversity architecture).
- Following channel(s) was (were) selected for the final test as listed below.

EUT CONFIGURE MODE	AVAILABLE CHANNEL	TESTED CHANNEL	MODULATION TYPE
A, B	1	1	ASK

RADIATED EMISSION TEST:

- Pre-Scan has been conducted to determine the worst-case mode from all possible combinations between available modulations, data rates, XYZ Axis and antenna ports (if EUT with antenna diversity architecture).
- Following channel(s) was (were) selected for the final test as listed below.

EUT CONFIGURE MODE	AVAILABLE CHANNEL	TESTED CHANNEL	MODULATION TYPE	AXIS
A	1	1	ASK	Z

FREQUENCY STABILITY:

- Pre-Scan has been conducted to determine the worst-case mode from all possible combinations between available modulations, data rates and antenna ports (if EUT with antenna diversity architecture).
- Following channel(s) was (were) selected for the final test as listed below.

EUT CONFIGURE MODE	AVAILABLE CHANNEL	TESTED CHANNEL	MODULATION TYPE
A ~ C	1	1	ASK

TEST CONDITION:

APPLICABLE TO	EUT CONFIGURE MODE	ENVIRONMENTAL CONDITIONS	INPUT POWER	TESTED BY
PLC	A	20deg. C, 68%RH	120Vac, 60Hz (SYSTEM)	Chad Lee
	B	20deg. C, 68%RH	120Vac, 60Hz	Chad Lee
RE	A	18deg. C, 76%RH	120Vac, 60Hz (SYSTEM)	Nick Chen
FS	A	20deg. C, 78%RH	230Vac, 50Hz (SYSTEM)	Jun Wu
	B	20deg. C, 78%RH	230Vac, 50Hz	Jun Wu
	C	20deg. C, 78%RH	3.7Vdc	Jun Wu



3.2 GENERAL DESCRIPTION OF APPLIED STANDARDS

The EUT is a RF product. According to the specifications of the manufacturer, it must comply with the requirements of the following standards:

FCC Part 15, Subpart C (15.225)

ANSI C63.4-2003

ANSI C63.10-2009

All test items have been performed and recorded as per the above standards.

NOTE: The product has been verified to comply with the requirements of FCC Part 15, Subpart B, Class B (DoC). The test report has been issued separately.

3.3 DESCRIPTION OF SUPPORT UNITS

The EUT has been tested as an independent unit together with other necessary accessories or support units. The following support units or accessories were used to form a representative test configuration during the tests.

NO.	PRODUCT	BRAND	MODEL NO.	SERIAL NO.	FCC ID
1	NOTEBOOK COMPUTER	DELL	PP05L	24729091408	FCC DoC Approved

NO.	SIGNAL CABLE DESCRIPTION OF THE ABOVE SUPPORT UNITS
1	N/A

NOTE: All power cords of the above support units are non shielded (1.8m).

4 TEST PROCEDURE AND RESULT

4.1 CONDUCTED EMISSION MEASUREMENT

4.1.1 LIMITS OF CONDUCTED EMISSION MEASUREMENT

FREQUENCY OF EMISSION (MHz)	CONDUCTED LIMIT (dB μ V)	
	Quasi-peak	Average
0.15-0.5	66 to 56	56 to 46
0.5-5	56	46
5-30	60	50

- NOTE:**
1. The lower limit shall apply at the transition frequencies.
 2. The limit decreases in line with the logarithm of the frequency in the range of 0.15 to 0.50 MHz.
 3. All emanations from a class A/B digital device or system, including any network of conductors and apparatus connected thereto, shall not exceed the level of field strengths specified above.

4.1.2 TEST INSTRUMENTS

DESCRIPTION & MANUFACTURER	MODEL NO.	SERIAL NO.	CALIBRATED DATE	CALIBRATED UNTIL
ROHDE & SCHWARZ Test Receiver	ESCS 30	100276	Dec. 31, 2010	Dec. 30, 2011
ROHDE & SCHWARZ Artificial Mains Network (for EUT)	ESH3-Z5	100219	Nov. 24, 2011	Nov. 23, 2012
LISN With Adapter (for EUT)	AD10	C10Ada-001	Nov. 24, 2011	Nov. 23, 2012
ROHDE & SCHWARZ Artificial Mains Network (for peripherals)	ESH3-Z5	100218	Dec. 08, 2011	Dec. 07, 2012
Software	ADT_Cond_V7.3.7	NA	NA	NA
Software	ADT_ISN_V7.3.7	NA	NA	NA
RF cable (JYEBAO)	5D-FB	Cable-C10.01	Feb. 22, 2011	Feb. 21, 2012
SUHNER Terminator (For ROHDE & SCHWARZ LISN)	65BNC-5001	E1-010773	Feb. 26, 2011	Feb. 25, 2012

- NOTE:**
1. The calibration interval of the above test instruments is 12 months and the calibrations are traceable to NML/ROC and NIST/USA.
 2. The test was performed in Shielded Room No. 10.
 3. The VCCI Site Registration No. C-1852.

4.1.3 TEST PROCEDURES

- a. The EUT was placed 0.4 meters from the conducting wall of the shielded room with EUT being connected to the power mains through a line impedance stabilization network (LISN). Other support units were connected to the power mains through another LISN. The two LISNs provide 50 ohm/ 50uH of coupling impedance for the measuring instrument.
- b. Both lines of the power mains connected to the EUT were checked for maximum conducted interference.
- c. The frequency range from 150kHz to 30MHz was searched. Emission levels under (Limit - 20dB) were not recorded.

4.1.4 DEVIATION FROM TEST STANDARD

No deviation

4.1.5 TEST SETUP

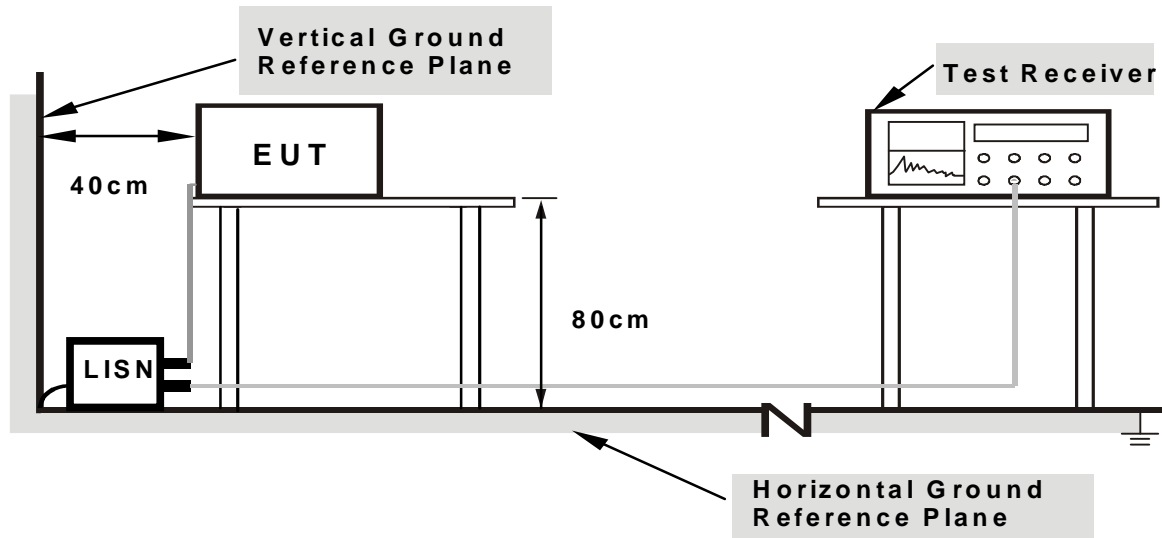

Note: 1. Support units were connected to second LISN.

2. Both of LISNs (AMN) are 80cm from EUT and at least 80cm from other units and other metal planes support units.

For the actual test configuration, please refer to the related item – Photographs of the Test Configuration.

4.1.6 EUT OPERATING CONDITIONS

MODE A

- Turn on the power of all equipment.
- Connected the EUT with Notebook PC placed on testing table.
- EUT ran a test program (provided by manufacture) to enable.
- Set the EUT under transmission condition continuously at specific channel frequency.

MODE B

- Turn on the power of all equipment.
- Connected the EUT with AC adapter placed on testing table.
- EUT ran a test program (provided by manufacture) to enable.
- Set the EUT under transmission condition continuously at specific channel frequency.

4.1.7 TEST RESULTS

PHASE	Line 1	6dB BANDWIDTH	9 kHz
CHANNEL	Channel 1	TEST MODE	A

No	Freq. [MHz]	Corr. Factor (dB)	Reading Value		Emission Level		Limit		Margin	
			[dB (uV)]		[dB (uV)]		[dB (uV)]		(dB)	
	Q.P.	AV.	Q.P.	AV.	Q.P.	AV.	Q.P.	AV.	Q.P.	AV.
1	0.361	0.19	40.48	-	40.67	-	58.71	48.71	-18.03	-
2	0.400	0.21	40.58	-	40.79	-	57.85	47.85	-17.06	-
3	0.879	0.23	36.81	-	37.04	-	56.00	46.00	-18.96	-
4	1.563	0.27	36.98	-	37.25	-	56.00	46.00	-18.75	-
5	2.408	0.33	29.68	-	30.01	-	56.00	46.00	-25.99	-
6	13.559	0.92	51.75	48.23	52.67	49.15	60.00	50.00	-7.33	-0.85

- REMARKS:**
1. Q.P. and AV. are abbreviations of quasi-peak and average individually.
 2. "-": The Quasi-peak reading value also meets average limit and measurement with the average detector is unnecessary.
 3. The emission levels of other frequencies were very low against the limit.
 4. Margin value = Emission level - Limit value
 5. Correction factor = Insertion loss + Cable loss
 6. Emission Level = Correction Factor + Reading Value.

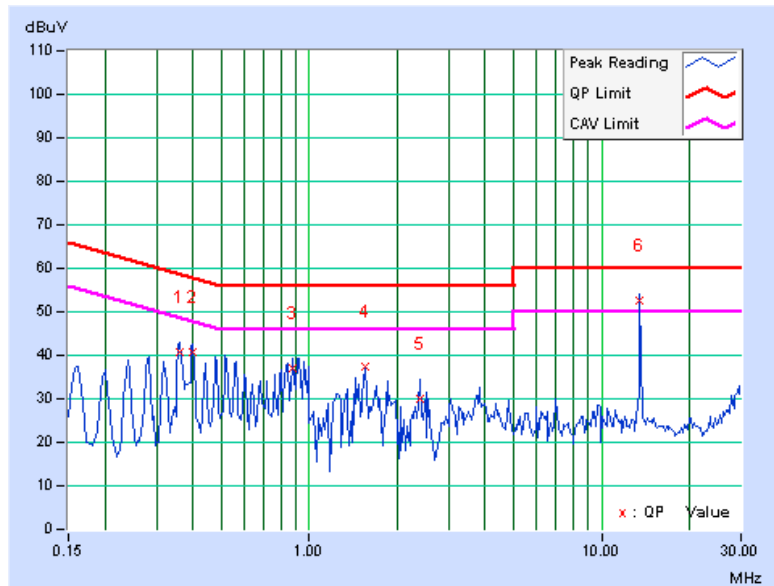



A D T

PHASE	Line 2	6dB BANDWIDTH	9 kHz
CHANNEL	Channel 1	TEST MODE	A

No	Freq. [MHz]	Corr. Factor (dB)	Reading Value		Emission Level		Limit		Margin	
			[dB (uV)]		[dB (uV)]		[dB (uV)]		(dB)	
			Q.P.	AV.	Q.P.	AV.	Q.P.	AV.	Q.P.	AV.
1	0.280	0.16	38.71	-	38.87	-	60.81	50.81	-21.94	-
2	0.361	0.19	40.60	-	40.79	-	58.70	48.70	-17.91	-
3	0.401	0.21	40.31	-	40.52	-	57.84	47.84	-17.32	-
4	0.521	0.22	37.92	-	38.14	-	56.00	46.00	-17.86	-
5	1.601	0.27	38.06	-	38.33	-	56.00	46.00	-17.67	-
6	13.560	0.73	51.34	48.10	52.07	48.83	60.00	50.00	-7.93	-1.17

- REMARKS:**
1. Q.P. and AV. are abbreviations of quasi-peak and average individually.
 2. "-": The Quasi-peak reading value also meets average limit and measurement with the average detector is unnecessary.
 3. The emission levels of other frequencies were very low against the limit.
 4. Margin value = Emission level - Limit value
 5. Correction factor = Insertion loss + Cable loss
 6. Emission Level = Correction Factor + Reading Value.

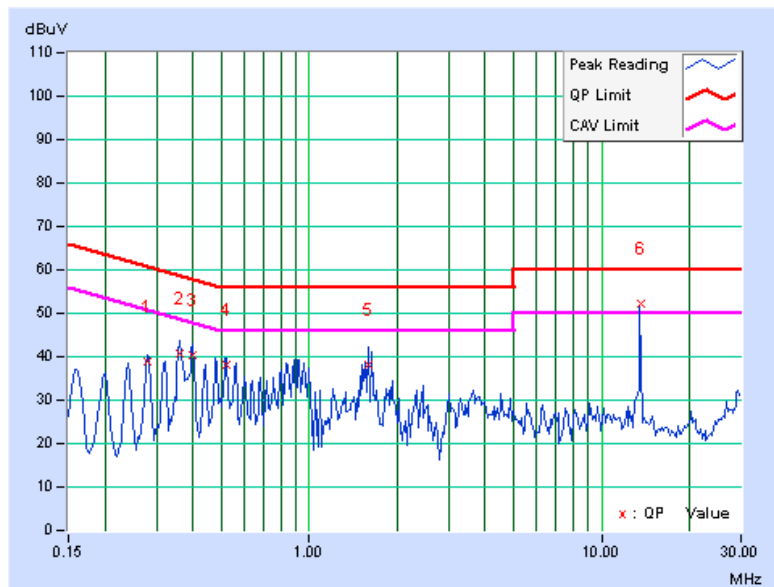



A D T

PHASE	Line 1	6dB BANDWIDTH	9 kHz
CHANNEL	Channel 1	TEST MODE	B

No	Freq. [MHz]	Corr. Factor (dB)	Reading Value		Emission Level		Limit		Margin	
			[dB (uV)]		[dB (uV)]		[dB (uV)]		(dB)	
			Q.P.	AV.	Q.P.	AV.	Q.P.	AV.	Q.P.	AV.
1	0.162	0.13	38.53	-	38.66	-	65.38	55.38	-26.72	-
2	0.358	0.19	46.82	-	47.01	-	58.78	48.78	-11.76	-
3	0.400	0.21	46.13	-	46.34	-	57.85	47.85	-11.51	-
4	0.882	0.23	40.89	-	41.12	-	56.00	46.00	-14.88	-
5	1.539	0.27	39.15	-	39.42	-	56.00	46.00	-16.58	-
6	13.559	0.92	50.34	48.11	51.26	49.03	60.00	50.00	-8.74	-0.97

- REMARKS:**
1. Q.P. and AV. are abbreviations of quasi-peak and average individually.
 2. "-": The Quasi-peak reading value also meets average limit and measurement with the average detector is unnecessary.
 3. The emission levels of other frequencies were very low against the limit.
 4. Margin value = Emission level - Limit value
 5. Correction factor = Insertion loss + Cable loss
 6. Emission Level = Correction Factor + Reading Value.

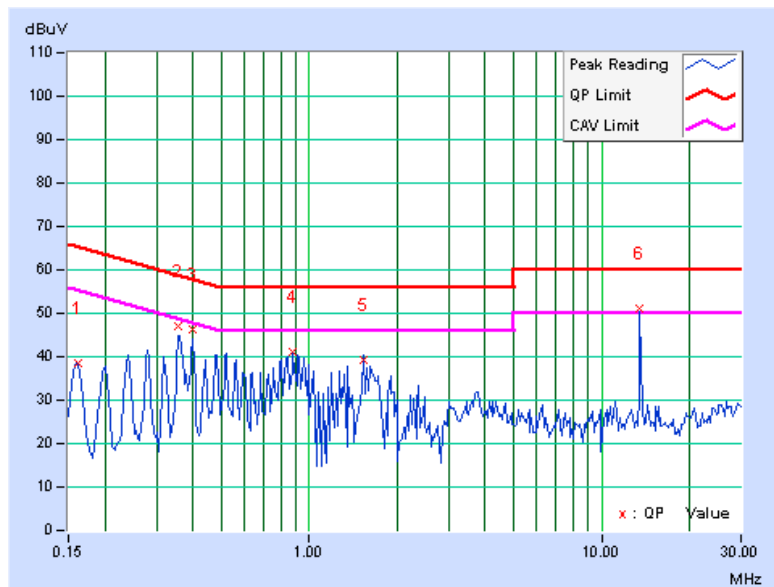



A D T

PHASE	Line 2	6dB BANDWIDTH	9 kHz
CHANNEL	Channel 1	TEST MODE	B

No	Freq. [MHz]	Corr. Factor (dB)	Reading Value		Emission Level		Limit		Margin	
			[dB (uV)]		[dB (uV)]		[dB (uV)]		(dB)	
			Q.P.	AV.	Q.P.	AV.	Q.P.	AV.	Q.P.	AV.
1	0.162	0.13	37.08	-	37.21	-	65.38	55.38	-28.17	-
2	0.360	0.19	41.64	-	41.83	-	58.74	48.74	-16.90	-
3	0.401	0.21	40.01	-	40.22	-	57.84	47.84	-17.62	-
4	0.877	0.23	36.66	-	36.89	-	56.00	46.00	-19.11	-
5	1.596	0.27	38.46	-	38.73	-	56.00	46.00	-17.27	-
6	13.559	0.73	50.26	48.08	50.99	48.81	60.00	50.00	-9.01	-1.19

- REMARKS:**
1. Q.P. and AV. are abbreviations of quasi-peak and average individually.
 2. "-": The Quasi-peak reading value also meets average limit and measurement with the average detector is unnecessary.
 3. The emission levels of other frequencies were very low against the limit.
 4. Margin value = Emission level - Limit value
 5. Correction factor = Insertion loss + Cable loss
 6. Emission Level = Correction Factor + Reading Value.

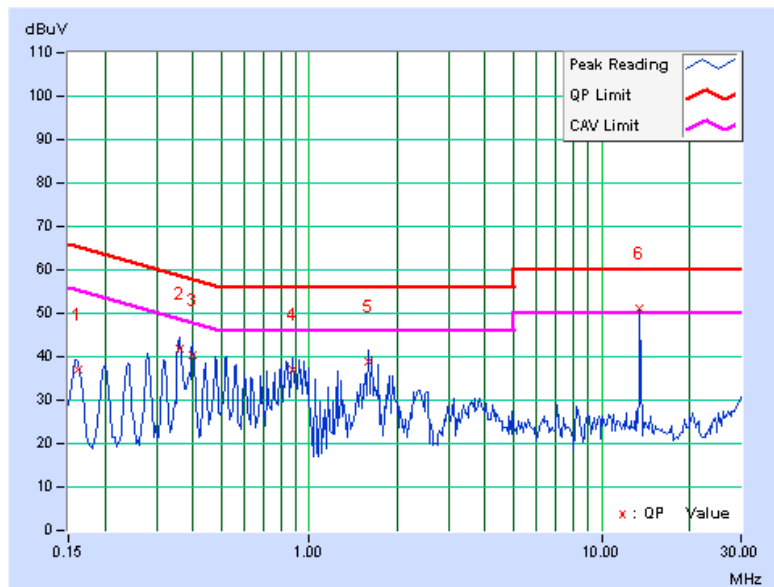

4.2 RADIATED EMISSION MEASUREMENT

4.2.1 LIMITS OF RADIATED EMISSION MEASUREMENT

According to 15.225 the field strength of Emissions from intentional radiators operated under these frequencies bands shall not exceed the following:

Fundamental Frequency (MHz)	Field Strength of Fundamental (dBuV/m) at 30m	Field Strength of Fundamental (dBuV/m) at 3m
13.553 – 13.567	Quasi-Peak	Quasi-Peak
	84	124

The measured field strength was extrapolated to distance 30 meters, using the formula that the limit of field strength varies as the inverse distance square (40dB per decade of distance)

Example:

$$\begin{aligned}
 13.56\text{MHz} &= 15848\text{uV/m} \quad 30\text{m} \\
 &= 84\text{dBuV/m} \quad 30\text{m} \\
 &= 84+20\log(30/3)^2 \quad 3\text{m} \\
 &= 124\text{dBuV/m}
 \end{aligned}$$

Field strength limits are at the distance of 3 meters, Emissions radiated outside of the specified bands, shall be according to the general radiated limits in 15.209 as following:

FREQUENCIES (MHz)	FIELD STRENGTH (microvolts/meter)	MEASUREMENT DISTANCE (meters)
0.009 ~ 0.490	2400/F(kHz)	300
0.490 ~ 1.705	24000/F(kHz)	30
1.705 ~ 30.0	30	30
30 ~ 88	100	3
88 ~ 216	150	3
216 ~ 960	200	3
Above 960	500	3

NOTE:

1. The lower limit shall apply at the transition frequencies.
2. Emission level (dBuV/m) = 20 log Emission level (uV/m).
3. As shown in 15.35(b), for frequencies above 1000MHz, the field strength limits are based on average detector, however, the peak field strength of any emission shall not exceed the maximum permitted average limits, specified above by more than 20dB under any condition of modulation.



4.2.2 TEST INSTRUMENT

DESCRIPTION & MANUFACTURER	MODEL NO.	SERIAL NO.	CALIBRATED DATE	CALIBRATED UNTIL
HP Preamplifier	8447D	2432A03504	Mar. 04, 2011	Mar. 03, 2012
HP Preamplifier	8449B	3008A01201	Mar. 04, 2011	Mar. 03, 2012
Agilent Spectrum Analyzer	E4446A	MY46180403	Jun. 22, 2011	Jun. 21, 2012
Schwarzbeck Antenna	VULB 9168	137	Apr. 12, 2011	Apr. 11, 2012
Schwarzbeck Antenna	VHBA 9123	480	May 06, 2011	May 05, 2012
ADT. Turn Table	TT100	0306	NA	NA
ADT. Tower	AT100	0306	NA	NA
Software	ADT_Radiated_V 7.6.15.9.2	NA	NA	NA
SUHNER RF cable	SF102	CABLE-CH6	Aug. 19, 2011	Aug. 18, 2012
Loop Antenna R & S	HFH2-Z2	100070	Feb. 03, 2010	Feb. 02, 2012

- NOTE:**
1. The calibration interval of the above test instruments is 12/24 months. And the calibrations are traceable to NML/ROC and NIST/USA.
 2. The horn antenna and HP preamplifier (model: 8449B) are used only for the measurement of emission frequency above 1GHz if tested.
 3. The test was performed in Chamber No. 6.
 4. The Industry Canada Reference No. IC 7450E-6.
 5. The FCC Site Registration No. is 447212.

4.2.3 TEST PROCEDURE

- a. The EUT was placed on the top of a rotating table 0.8 meters above the ground at a 3 meter semi-anechoic chamber. The table was rotated 360 degrees to determine the position of the highest radiation.
- b. The EUT was set 3 meters away from the interference-receiving antenna, which was mounted on the top of a variable-height antenna tower.
- c. The height of antenna is varied from one meter to four meters above the ground to determine the maximum value of the field strength. Both horizontal and vertical polarizations of the antenna are set to make the measurement.
- d. For each suspected emission, the EUT was arranged to its worst case and then the antenna was tuned to heights from 1 meter to 4 meters and the rotatable table was turned from 0 degrees to 360 degrees to find the maximum reading.
- e. The test-receiver system was set to quasi-peak detect function and specified bandwidth with maximum hold mode when the test frequency is below 1 GHz.
- f. If the emission level of the EUT in peak mode was lower than the limit specified, then testing could be stopped and the peak values of the EUT would be reported. Otherwise the emissions would be re-tested one by one using peak, quasi-peak method or average method as specified and then reported in data sheet.
- g. For measurement of frequency above 1000 MHz, the EUT was set 3 meters away from the interference antenna and the detect function was set to Peak or Average.

4.2.4 DEVIATION FROM TEST STANDARD

No deviation

4.2.5 TEST SETUP

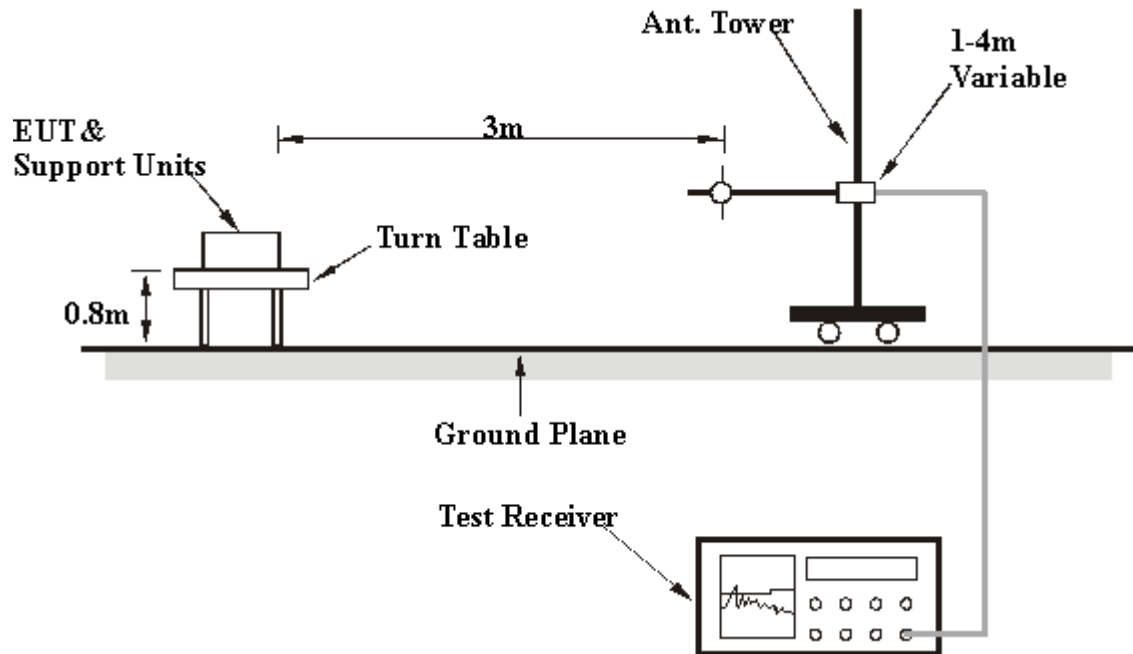

For the actual test configuration, please refer to the related item in this test report - Photographs of the Test Configuration.

4.2.6 EUT OPERATING CONDITION

Same as item 4.1.6.



A D T

4.2.7 TEST RESULT

EUT TEST CONDITION		MEASUREMENT DETAIL	
CHANNEL	Channel 1	FREQUENCY RANGE	13.56MHz
INPUT POWER (SYSTEM)	120Vac, 60Hz	DETECTOR FUNCTION	Quasi-Peak
ENVIRONMENTAL CONDITIONS	18deg. C, 76% RH	TESTED BY	Nick Chen
TEST MODE	A		

TEST DISTANCE: LOOP ANTENNA OPEN AT 3 M								
No.	Freq. (MHz)	Emission Level (dBuV/m)	Limit (dBuV/m)	Margin (dB)	Antenna Height (m)	Table Angle (Degree)	Raw Value (dBuV)	Correction Factor (dB/m)
1	13.56	43.5 QP	124.0	-80.5	1.00	186	23.25	20.27

- REMARKS:**
1. Emission level(dBuV/m)=Raw Value(dBuV) + Correction Factor(dB/m)
 2. Correction Factor(dB/m) = Antenna Factor (dB/m) + Cable Factor (dB)
 3. The other emission levels were very low against the limit.
 4. Margin value = Emission level – Limit value.
 5. "*" = Fundamental frequency.
 6. Loop Antenna was used for all frequency below 30MHz.

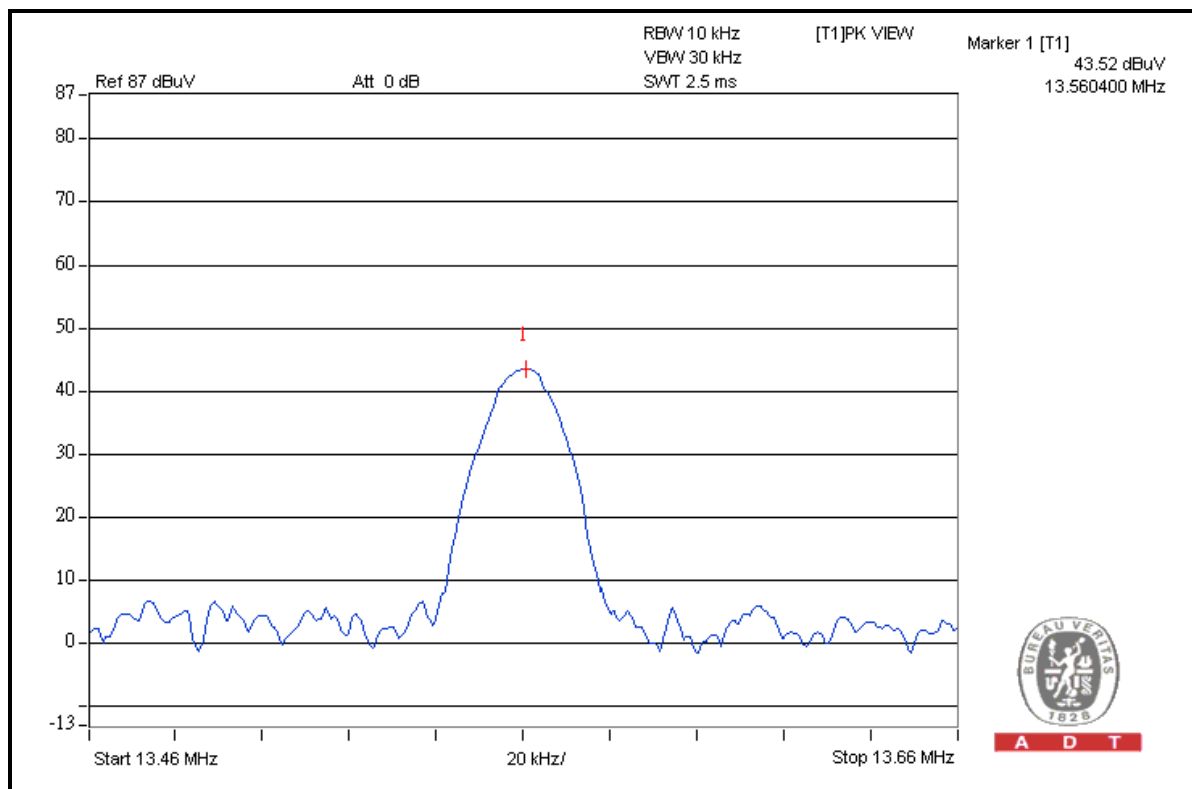

A D T



A D T

EUT TEST CONDITION		MEASUREMENT DETAIL	
CHANNEL	Channel 1	FREQUENCY RANGE	13.56MHz
INPUT POWER (SYSTEM)	120Vac, 60Hz	DETECTOR FUNCTION	Quasi-Peak
ENVIRONMENTAL CONDITIONS	18deg. C, 76% RH	TESTED BY	Nick Chen
TEST MODE	A		

TEST DISTANCE: LOOP ANTENNA CLOSE AT 3 M								
No.	Freq. (MHz)	Emission Level (dBuV/m)	Limit (dBuV/m)	Margin (dB)	Antenna Height (m)	Table Angle (Degree)	Raw Value (dBuV)	Correction Factor (dB/m)
1	13.56	51.4 QP	124.0	-72.6	1.00	233	31.17	20.27

- REMARKS:**
1. Emission level(dBuV/m)=Raw Value(dBuV) + Correction Factor(dB/m)
 2. Correction Factor(dB/m) = Antenna Factor (dB/m) + Cable Factor (dB)
 3. The other emission levels were very low against the limit.
 4. Margin value = Emission level – Limit value.
 5. "*" = Fundamental frequency.
 6. Loop Antenna was used for all frequency below 30MHz.

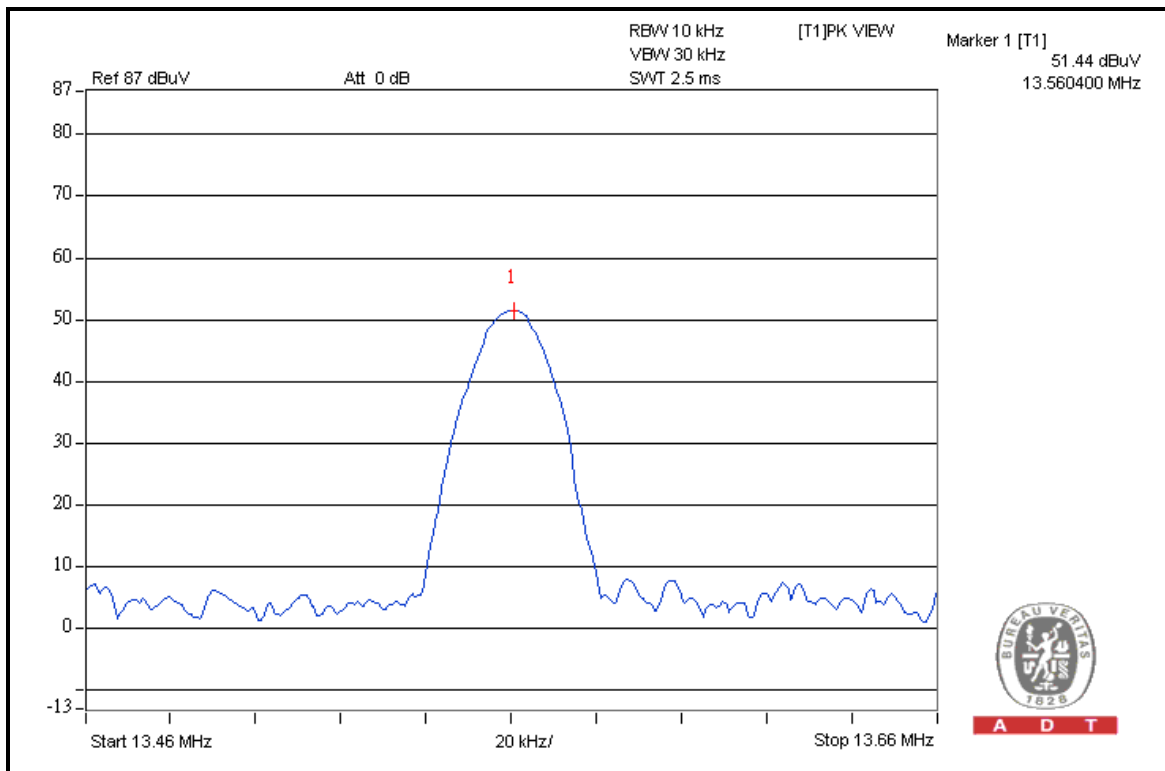

A D T



A D T

EUT TEST CONDITION		MEASUREMENT DETAIL	
CHANNEL	Channel 1	FREQUENCY RANGE	9kHz – 30MHz
INPUT POWER (SYSTEM)	120Vac, 60Hz	DETECTOR FUNCTION	Quasi-Peak
ENVIRONMENTAL CONDITIONS	18deg. C, 76% RH	TESTED BY	Nick Chen
TEST MODE	A		

TEST DISTANCE: LOOP ANTENNA OPEN AT 3 M								
No.	Freq. (MHz)	Emission Level (dBuV/m)	Limit (dBuV/m)	Margin (dB)	Antenna Height (m)	Table Angle (Degree)	Raw Value (dBuV)	Correction Factor (dB/m)
1	27.12	31.0 QP	69.5	-38.5	1.00	154	9.11	21.85

- REMARKS:**
1. Emission level(dBuV/m)=Raw Value(dBuV) + Correction Factor(dB/m)
 2. Correction Factor(dB/m) = Antenna Factor (dB/m) + Cable Factor (dB)
 3. The other emission levels were very low against the limit.
 4. Margin value = Emission level – Limit value.
 5. Loop Antenna was used for all frequency below 30MHz.

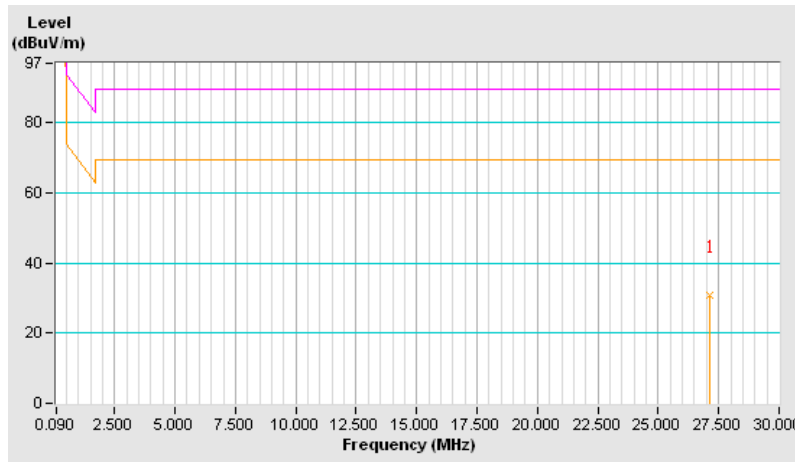



A D T

EUT TEST CONDITION		MEASUREMENT DETAIL	
CHANNEL	Channel 1	FREQUENCY RANGE	9kHz – 30MHz
INPUT POWER (SYSTEM)	120Vac, 60Hz	DETECTOR FUNCTION	Quasi-Peak
ENVIRONMENTAL CONDITIONS	18deg. C, 76% RH	TESTED BY	Nick Chen
TEST MODE	A		

TEST DISTANCE: LOOP ANTENNA CLOSE AT 3 M								
No.	Freq. (MHz)	Emission Level (dBuV/m)	Limit (dBuV/m)	Margin (dB)	Antenna Height (m)	Table Angle (Degree)	Raw Value (dBuV)	Correction Factor (dB/m)
1	27.12	32.7 QP	69.5	-36.8	1.00	197	10.81	21.85

- REMARKS:**
1. Emission level(dBuV/m)=Raw Value(dBuV) + Correction Factor(dB/m)
 2. Correction Factor(dB/m) = Antenna Factor (dB/m) + Cable Factor (dB)
 3. The other emission levels were very low against the limit.
 4. Margin value = Emission level – Limit value.
 5. Loop Antenna was used for all frequency below 30MHz.

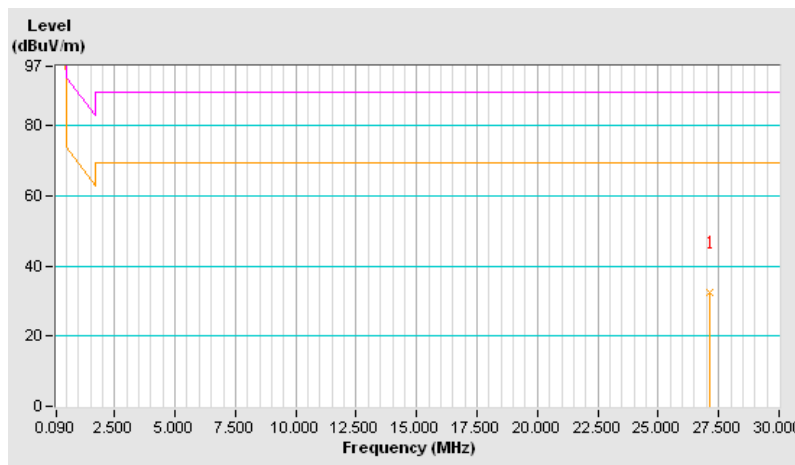



A D T

EUT TEST CONDITION		MEASUREMENT DETAIL	
CHANNEL	Channel 1	FREQUENCY RANGE	30-1000MHz
INPUT POWER (SYSTEM)	120Vac, 60Hz	DETECTOR FUNCTION	Quasi-Peak
ENVIRONMENTAL CONDITIONS	18deg. C, 76% RH	TESTED BY	Nick Chen
TEST MODE	A		

ANTENNA POLARITY & TEST DISTANCE: HORIZONTAL AT 3 M								
NO.	FREQ. (MHz)	EMISSION LEVEL (dBuV/m)	LIMIT (dBuV/m)	MARGIN (dB)	ANTENNA HEIGHT (m)	TABLE ANGLE (Degree)	RAW VALUE (dBuV)	CORRECTION FACTOR (dB/m)
1	134.91	35.5 QP	43.5	-8.0	1.03 H	208	22.19	13.31
2	172.03	30.8 QP	43.5	-12.8	1.17 H	133	16.79	13.96
3	285.01	32.4 QP	46.0	-13.6	1.05 H	181	17.42	14.99
4	297.92	32.3 QP	46.0	-13.7	1.06 H	175	16.77	15.51
5	796.64	32.9 QP	46.0	-13.1	1.28 H	307	6.41	26.53
6	825.69	32.3 QP	46.0	-13.7	1.00 H	193	5.37	26.93
ANTENNA POLARITY & TEST DISTANCE: VERTICAL AT 3 M								
NO.	FREQ. (MHz)	EMISSION LEVEL (dBuV/m)	LIMIT (dBuV/m)	MARGIN (dB)	ANTENNA HEIGHT (m)	TABLE ANGLE (Degree)	RAW VALUE (dBuV)	CORRECTION FACTOR (dB/m)
1	62.28	30.7 QP	40.0	-9.3	1.07 V	226	17.54	13.14
2	76.81	38.1 QP	40.0	-1.9	1.11 V	214	27.09	11.00
3	99.40	30.4 QP	43.5	-13.1	1.24 V	148	20.95	9.42
4	796.64	36.2 QP	46.0	-9.8	1.07 V	349	9.63	26.53
5	825.69	32.7 QP	46.0	-13.3	1.23 V	295	5.77	26.93
6	893.48	41.3 QP	46.0	-4.7	1.17 V	271	13.55	27.71
7	948.35	33.0 QP	46.0	-13.0	1.00 V	331	4.58	28.42

- REMARKS:**
1. Emission level (dBuV/m) = Raw Value (dBuV) + Correction Factor (dB/m).
 2. Correction Factor (dB/m) = Antenna Factor (dB/m) + Cable Factor (dB).
 3. The other emission levels were very low against the limit.
 4. Margin value = Emission level – Limit value.

4.3 FREQUENCY STABILITY

4.3.1 LIMITS OF FREQUENCY STABILITY MEASUREMENT

The frequency tolerance of the carrier signal shall be maintained within +/- 0.01% of the operating frequency over a temperature variation of 0 degrees to 40 degrees C at normal supply voltage, and for a variation in the primary supply voltage from 85% to 115% of the rated supply voltage at a temperature of 20 degrees C. For battery operated equipment, the equipment tests shall be performed using a new battery.

4.3.2 TEST INSTRUMENTS

DESCRIPTION & MANUFACTURER	MODEL NO.	SERIAL NO.	CALIBRATED DATE	CALIBRATED UNTIL
SPECTRUM ANALYZER	FSP 40	100036	Apr. 29, 2011	Apr. 28, 2012
Temperature & Humidity Chamber	MHU-225AU	920409	May 09, 2011	May 08, 2012

NOTE: The calibration interval of the above test instruments is 12 months and the calibrations are traceable to NML/ROC and NIST/USA.

4.3.3 TEST PROCEDURE

- a. The EUT was placed inside the environmental test chamber and powered by nominal DC voltage.
- b. Turn the EUT on and couple its output to a spectrum analyzer.
- c. Turn the EUT off and set the chamber to the highest temperature specified.
- d. Repeat step b and c with the temperature chamber set to the lowest temperature.
- e. The test chamber was allowed to stabilize at +20 degree C for a minimum of 30 minutes. The supply voltage was then adjusted on the EUT from 85% to 115% and the frequency record.

4.3.4 DEVIATION FROM TEST STANDARD

No deviation.

4.3.5 TEST SETUP

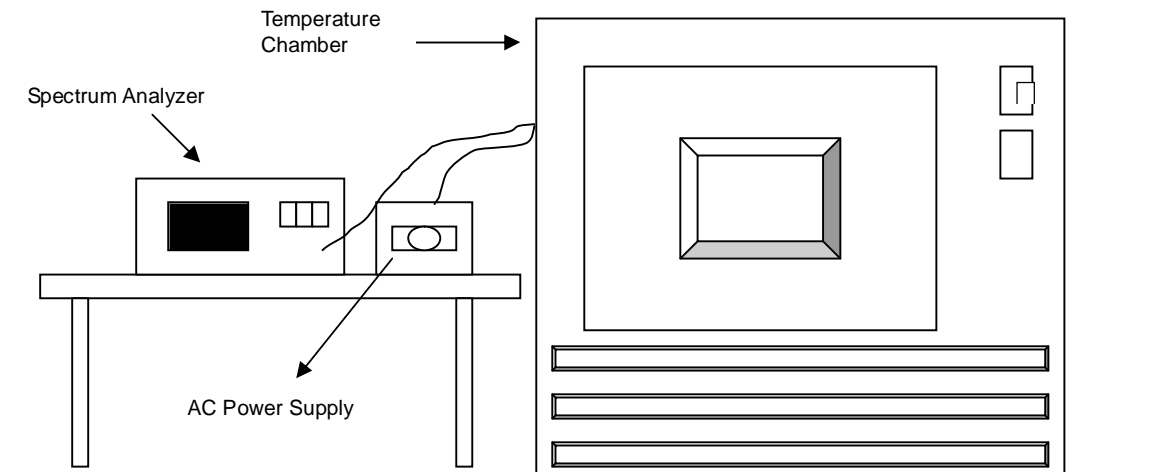

4.3.6 EUT OPERATING CONDITION

Same as Item 4.1.6.

4.3.7 TEST RESULTS

Mode A:

OPERATING FREQUENCY: 13.56MHz		LIMIT: $\pm 0.01\%$	
TEMP. (°C)	POWER SUPPLY (Vdc)	(MHz)	(%)
20	5.0	13.5605	0.003687
	5.75	13.5606	0.004425
	4.25	13.5607	0.005162
0	5.0	13.5603	0.002212
40	5.0	13.5604	0.002950

Note: Operating temperature of EUT is 0 degrees C to 40 degrees C.

Mode B:

OPERATING FREQUENCY: 13.56MHz		LIMIT: $\pm 0.01\%$	
TEMP. (°C)	POWER SUPPLY (Vac)	(MHz)	(%)
20	120	13.5604	0.002950
	138	13.5606	0.004425
	102	13.5608	0.005900
0	120	13.5603	0.002212
40	120	13.5604	0.002950

Note: Operating temperature of EUT is 0 degrees C to 40 degrees C.



A D T

Mode C:

OPERATING FREQUENCY: 13.56MHz		LIMIT: $\pm 0.01\%$	
TEMP. (°C)	POWER SUPPLY (Vdc)	(MHz)	(%)
20	3.7	13.5603	0.002212
	4.255	13.5604	0.002950
	3.145	13.5605	0.003687
0	3.7	13.5601	0.000737
40	3.7	13.5602	0.001475

Note: Operating temperature of EUT is 0 degrees C to 40 degrees C.



A D T

5 PHOTOGRAPHS OF THE TEST CONFIGURATION

Please refer to the attached file (Test Setup Photo).



6 INFORMATION ON THE TESTING LABORATORIES

We, Bureau Veritas Consumer Products Services (H.K.) Ltd., Taoyuan Branch, were founded in 1988 to provide our best service in EMC, Radio, Telecom and Safety consultation. Our laboratories are accredited and approved according to ISO/IEC 17025.

Copies of accreditation and authorization certificates of our laboratories obtained from approval agencies can be downloaded from our web site: www.adt.com.tw/index.5/phtml. If you have any comments, please feel free to contact us at the following:

Linko EMC/RF Lab:
Tel: 886-2-26052180
Fax: 886-2-26051924

Hsin Chu EMC/RF Lab:
Tel: 886-3-5935343
Fax: 886-3-5935342

Hwa Ya EMC/RF/Safety / Telecom Lab:
Tel: 886-3-3183232
Fax: 886-3-3185050

Email: service.adt@tw.bureauveritas.com
Web Site: www.adt.com.tw

The address and road map of all our labs can be found in our web site also.



A D T

7 APPENDIX A – MODIFICATIONS RECORDERS FOR ENGINEERING CHANGES TO THE EUT BY THE LAB

No modifications were made to the EUT by the lab during the test.

--- END ---