

Operating Manual

Model: C300A-BK



CAUTION: To reduce the risk of fire or electric shock, do not expose this appliance to rain or moisture.

WARNING: To prevent electric shock, do not use this plug with an extension cord, receptacle or other outlet unless the blades can be fully inserted to prevent blade exposure.

Important Safety Instructions





1. Read these instructions – All the safety and operating instructions should be read before this product is operated.
2. Keep these instructions–The safety and operating instructions should be retained for future reference.
3. Heed all warnings–All warnings on the appliance and in the operating instructions should be adhered to.
4. Follow all instructions – All operating and use instructions should be followed.
5. Do not use this apparatus near water – The appliance should not be used near water or moisture –for example, in a wet basement or near a swimming pool, and the like.
6. Clean only with dry cloth.
7. Do not block any ventilation openings. Install in accordance with the manufacturer's instructions.

8. Do not install near any heat sources such as radiations, heat registers, stoves, or other apparatus (including amplifiers) that produce heat.
9. Do not defeat the safety purpose of the polarized or grounding plug. A polarized plug has two blades with one wider than the other. A grounding plug has two blades and a third grounding prong. The wide blade or the third prong is provided for your safety. If the provided plug does not fit into your outlet, consult an electrician for replacement of the obsolete outlet.
10. Protect the power cord from being walked on or pinched particularly at the plugs, convenience receptacles, and at the point where they exit from the apparatus.
11. Only use attachments/accessories specified by the manufacturer.
12. Use only with the cart, stand, tripod, bracket, or table specified by the manufacturer, or sold with the apparatus. When a cart or rack is used, use caution when moving the cart/apparatus combination to avoid injury from tip-over.
13. Refer all servicing to qualified personnel. Servicing is required when the apparatus has been damaged in any way, such as power supply cord or plug is damaged, liquid has been spilled or objects have fallen into the apparatus has been exposed to rain or moisture, does not operate normally, or has been dropped.
14. Unplug the apparatus during lightning storms or when unused for long periods of time.
15. **WARNING:** to reduce the risk of fire or electric shock, do not expose this

apparatus to rain or moisture. The apparatus shall not be exposed to dripping or splashing and that no objects filled with liquids, such as vases, shall be placed on the apparatus.



16. -This lightning flash with arrowhead symbol within an equilateral triangle is intended to alert the user to the presence of non-insulated “dangerous voltage” within the product’s enclosure that may be of sufficient magnitude to constitute a risk of electric shock.
- Warning: To reduce the risk of electric shock, do not remove cover (or back) as there are no user-serviceable parts inside. Refer servicing to qualified personnel.
- The exclamation point within and equilateral triangle is intended to alert the user to the presence of important operating and maintenance instructions in the literature accompanying the appliance.
17. The use of the equipment in moderate climate.
18. The mains plug is used as the disconnect device.
- The socket-outlet shall be installed near the equipment and shall be easily accessible.
19. The ventilation should not be impeded by covering the ventilation openings with items such as, newspapers, tablecloths, curtains, etc.
20. No naked flame sources, such as lighted candles, should be placed on the apparatus.
21. The symbol with \sim indicates AC voltage.

22. The symbol with  indicates DC voltage.
23. CAUTION: These servicing instructions are for use by qualified service personnel only. To reduce the risk of electric shock, do not perform any servicing other than that contained in the operating instructions unless you are qualified to do so.
24.  For indoor use only.
25.  The symbol indicates polarity of D.C. power connector.
26.  The symbol indicates energy efficiency marking..
27. Use only power supplies listed in the user instructions.
28. WARNING: Please refer the information on exterior bottom enclosure for electrical and safety information before installing or operating the apparatus.

Product Overview

Top view:

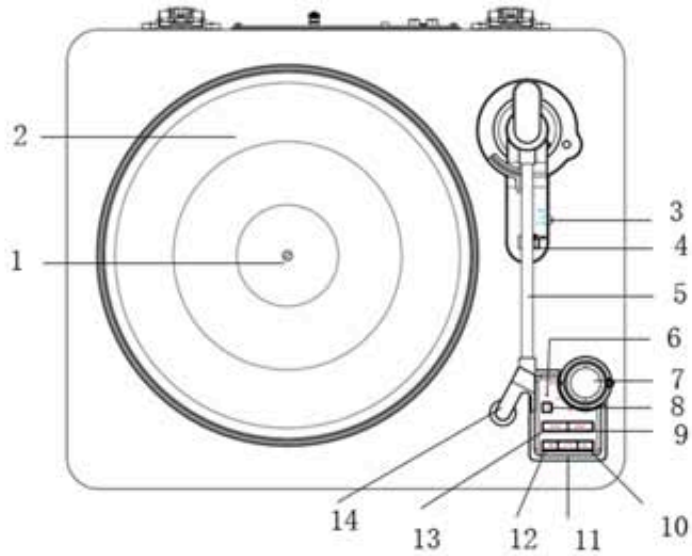

- | | |
|---|-----------------------------|
| 1. Spindle | 8. Bluetooth button |
| 2. Aluminium turntable | 9. Start button |
| 3. Record size selection switch | 10. Fast forward button |
| 4. Tone arm rest holder | 11. Up/Down button |
| 5. Tone arm | 12. Fast backward button |
| 6. Bluetooth indicator | 13. Stop button |
| 7. Power/RPM selector switch (OFF-33-45) | 14. Moving magnet cartridge |

Rear View:

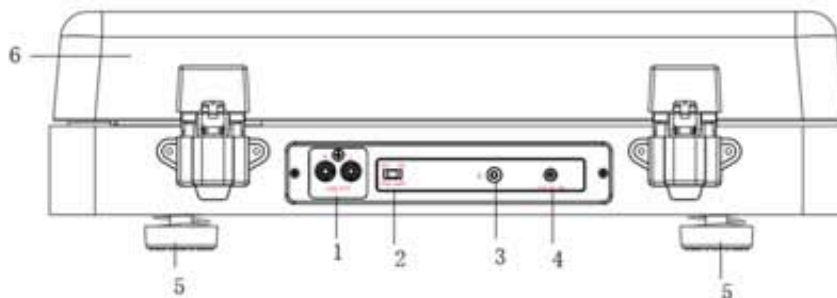

- | | |
|--------------------------|------------------|
| 1. RCA jack | 4. DC IN jack |
| 2. Pre-amp OFF/ON switch | 5. Under-chassis |
| 3. Ground terminal | 6. Dust cover |

Setting up your turntable

Please carefully remove the product from the packing case and unpack all packing materials. Check that all accessories are complete. Then choose a flat and safe place to assemble the turntable.

Installing the metal platter and turntable mat

Note: The belt is preinstalled on the bottom of the metal platter

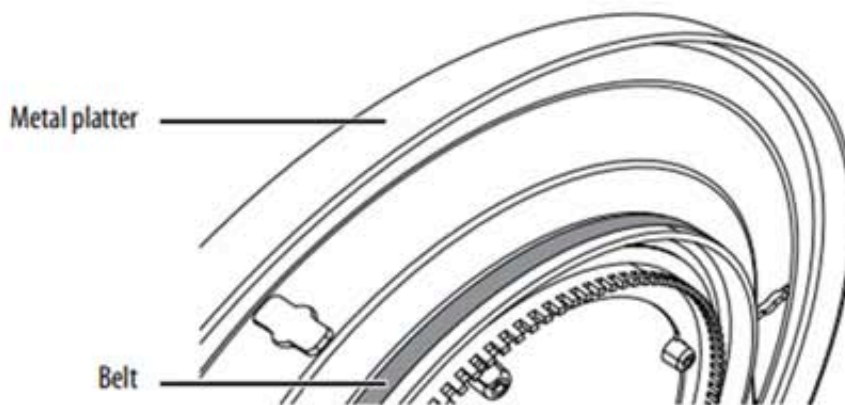

1. Make sure that the belt is not twisted, then use your thumb to stretch the belt until it reaches the round hold in platter.

Note: Make sure that you place the belt on the metal track and not on the section with teeth.

2. Still holding the belt, flip the platter over, then insert the platter onto the spindle in the center of your turntable.

3. Align the round hole in the platter with the pulley and use your finger to hook the belt onto the pulley.

4. Place the turntable mat on the platter.

Note: When you want to take out the platter from the turntable, remove the mat first, then grasp the platter and pull it upward. This is especially

important if you are shipping your turntable to prevent the platter from shaking.

Installing the dust cover

1. Insert the dust cover hinges into the hinge bases on the back panel of the unit.

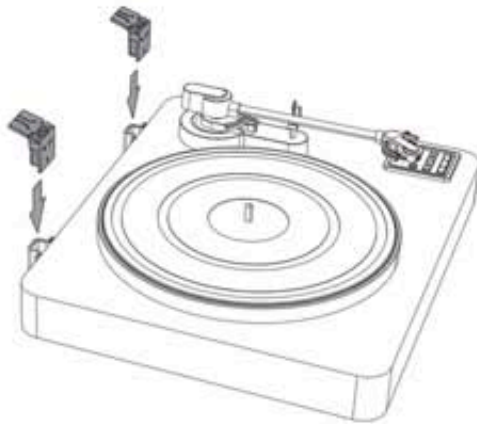

2. Hold the dust cover and insert it into the hinges.



Power the turntable

You can power the device with the supplied AC/DC adaptor. Check the rating plate on the AC/DC adapter with your mains power voltage before

powering the device on. The AC/DC adapter is 100-240V~50/60Hz input, 12V $\overline{\text{---}}$ 0.6A output.

Note: To disconnect the device from the mains, pull out the mains plug out of the wall outlet.

Remove the stylus cover

Please remove the stylus cover before playing the record.

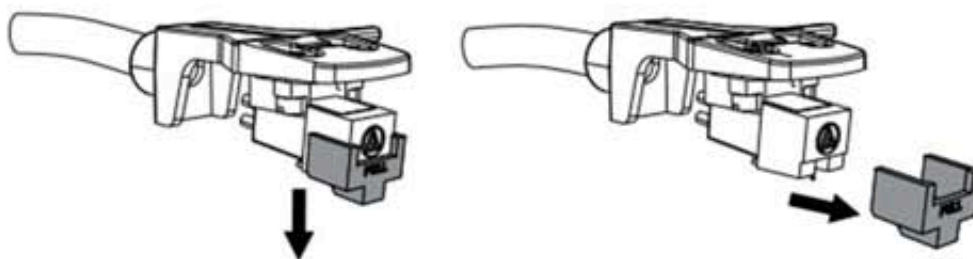

Using your turntable

Playing a record

1. Gently open the top cover.

Note: Be careful not to pinch your finger when opening or closing the top cover.

2. Place a vinyl record on the turntable.

3. Select the appropriate speed by turning the RPM selector switch to 33 or 45. And at the same time, you must select the appropriate size by slid the SIZE selector switch to 7' or 12'.

Note: 45 RMP record is 7', 33 RMP record is 12'

4. Remove the tone arm-rest catch to release the tone arm.

5. Press START button, the tone arm will automatically move to the record and start playing the record.

6. Press the **Fast forward/Fast Backward button** to jump the track. Long press will continuously jump the track.

7. Press UP/DOWN button, the tone arm will be raised or lowered. The playback will play or pause.

8. After the record is finished playing, the record stops rotating, and the tone arm will automatically returns to the tone arm seat.

NOTE: When not in use, please fasten the arm lock to prevent the arm from loosening and damaging the stylus or turntable.

Listening to music using Bluetooth speakers

1. Turn the switch to your record type, 33 or 45. And select the size of record, 7' or 12'

2. Put your Bluetooth speaker in pairing mode.

NOTE: Make sure that Bluetooth is off on any devices in the vicinity that will automatically connect to your speaker.

3. On the turntable, press the Bluetooth button enter to pairing , the Bluetooth indicator will flash blue.

4. When connected successfully, the Bluetooth indicator lights solid.

5. Long press the Bluetooth button can disconnect the currently connected Bluetooth speaker.

Note: If pairing fails, the Bluetooth indicator will light red. You can press

the Bluetooth button to restart the pairing or long press the Bluetooth button to exit the Bluetooth transmission.

Listening to through the RCA jacks

1. Plug the red and white connectors on the included RCA cable into the RCA jack on the back of your turntable, red to red and white to white.
2. Plug the other end of the cable into your speakers, red to right speaker and white to left speaker.
3. Toggle the PRE-AMP ON/OFF switch to selector the output mode.

Connected external device	Switch position
Device with PHONO input	OFF
Device without PHONO input	ON

NOTE: The volume knob doesn't adjust the volume of the external speaker when using the RCA cable.

Replacing the stylus (Part number: Audio-Technica ATN3600L)

The stylus should last about 300 hours under normal use. However, we recommend that you replace the stylus as soon as you notice a change in sound quality. Prolonged use of a worn-out stylus can damage records.

- 1 Turn the RPM selector switch to OFF to turn off the power.
- 2 Remove the stylus by pulling it downward and forward at the same time.

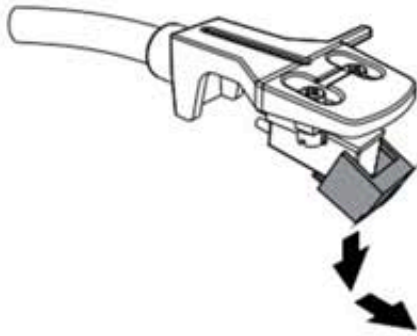

3 Insert the new stylus upwards into the slot under the head, then push upward until the tip locks into place.

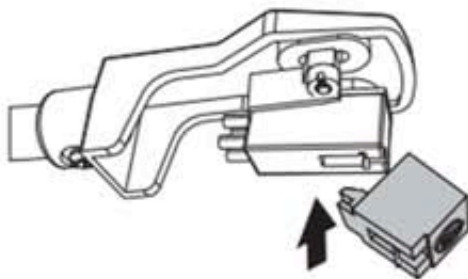

CAUTIONS:

- Do not remove or bend the stylus.
- Do not touch the needle to avoid injury your hand.
- Keep out of reach of children

Cleaning your turntable

- Only use a clean, dry cloth.
- Never use chemicals, detergents, or abrasives.
- When you're not using your turntable, close the dust cover to prevent dust or other dirt from getting onto your turntable.

CAUTION: Do not spill any liquid on the turntable. This will damage your turntable. If something happens to spill onto the turntable, immediately wipe it clean with a soft, clean cloth.

Troubleshooting

Check this list for possible troubleshooting solutions before calling for service.

	Problem	Cause	Solution
THE WHOLE UNIT	Power does not come on	Unit is unplugged.	Connect the unit to the AC/DC adaptor power supply.
	No sound from the speakers.	The volume is turned down to MIN; The working input does not match the source input.	Adjust the volume; Reselect a source.
	The sound is noisy.	The unit is too close to a TV set or another similar appliance.	Turn off the TV or other appliance, and re-locate the unit.
	The unit has no response or could not reset.	External factors such as ESD (Electro-static discharge) affect the unit.	Remove the power cord and all power supply devices, then re-plug in the unit after one minute.
PHONO PLAYER	The sound is noisy when playing the record.	The stylus is not placed in the middle center.	Replace a stylus which is placed in middle center.
	The sound is noisy when used for a period of time.	The stylus is damaged.	Please change a new stylus.
	The Phono doesn't work.	The record doesn't fit with the unit. You may choose the 78rpm record to playback.	Select one appropriate record to playback.(33 or 45RPM)
BLUETOOTH	Unable to pair with a Bluetooth device.	(1). The unit is not switch to Bluetooth transmitting mode. (2) Your home Bluetooth amplifier device doesn't turn on. (3) Your device is too far from the unit or there're some obstacle (e.g.wall) between your device and the unit.	(1) Press the PARI button to ensure the unit is switched to transmitting mode. (2) Turn on your home Bluetooth amplifier device (3) Move your Bluetooth device closer to unit.
		The Bluetooth pairing is not successful.	(1) Turn off other Bluetooth device to ensure that your Bluetooth amplifier device which has disconnected to other Bluetooth device. (2) Or delete your Bluetooth connection name on other Bluetooth device (have connected before) paired list. It makes sure that the unit can search your Bluetooth amplifier easily and quickly. (3) Check your Bluetooth device whether it use BQB certified receive or not.

Specifications

General

Power Source.....AC/DC Adaptor
Manufacturer.....Guangdong Leetac Electronics Technology Co.,Ltd.
Model.....GRP12W-120060
Input.....100-240V~, 50/60Hz, 0.4A
Output.....12.0 V \approx 0.6 A; 7.2W
Main Unit input.....12.0 V \approx 0.6 A;
Dimensions (W x H x D).....440mm x 137mm x 383mm (approx.)
Weight.....4.458kg (approx.)(not include accessory)

RECORD PLAYER

Motor.....DC servo motor
Drive System.....Belt Drive
Speeds.....33-1/3 rpm, 45 rpm,
Wow Flutter.....Less than 0.25% (WTD)
S/N Ratio.....50 dB
Cartridge Type.....Moving Magnetic Cartridge
Stylus.....AT3600L
RCA OUT.....200-280 mV (5 cm/sec at 1 KHz-10dB)
Phono out.....3-4mv ((5 cm/sec at 1 KHz-10dB)

BLUETOOTH TRANSMIT

Bluetooth Version.....Bluetooth V5.3
Bluetooth supports.....HFP, A2DP, AVRCP profiles
Bluetooth Frequency range.....2.402GHz-2.480GHz
Operating Distance.....7 meters (30 ft.)

FCC Statement

This device complies with Part 15 of the FCC Rules. Operation is subject to the following two conditions: (1) This device may not cause harmful interference, and (2) this device must accept any interference received, including interference that may cause undesired operation.

NOTE: This equipment has been tested and found to comply with the limits for a Class B digital device, pursuant to Part 15 of the FCC Rules. These limits are designed to provide reasonable protection against harmful interference in a residential installation. This equipment generates uses and can radiate radio frequency energy and, if not installed and used in accordance with the instructions, may cause harmful interference to radio communications. However, there is no guarantee that interference will not occur in a particular installation. If this equipment does cause harmful interference to radio or television reception, which can be determined by turning the equipment off and on, the user is encouraged to try to correct the interference by one of the following measures:

- Reorient or relocate the receiving antenna.
- Increase the separation between the equipment and receiver.
- Connect the equipment into an outlet on a circuit different from that to which the receiver is connected.
- Consult the dealer or an experienced radio/TV technician for help.

WARNING: Any changes or modifications not expressly approved by the party responsible for compliance could void the user's authority to operate this equipment.

The device must not be co-located or operating in conjunction with any other antenna or transmitter.

To maintain compliance with the FCC's RF exposure guidelines, place the product at least 20cm from nearby persons.