

TEST REPORT

Report No.: 20061339HKG-001

Musical Electronics Ltd.

Application For Certification
(Original Grant)

FCC ID: AUI-TBT01A

Transceiver

Prepared and Checked by:

Approved by:

Signed On File
Wong Cheuk Ho, Herbert
Lead Engineer

Wong Kwok Yeung, Kenneth
Senior Lead Engineer
Date: November 27, 2020

Intertek's standard Terms and Conditions can be obtained at our website <http://www.intertek.com/terms/>.

The test report only allows to be revised within the retention period unless further standard or the requirement was noticed.

This report is for the exclusive use of Intertek's Client and is provided pursuant to the agreement between Intertek and its Client. Intertek's responsibility and liability are limited to the terms and conditions of the agreement. Intertek assumes no liability to any party, other than to the Client in accordance with the agreement, for any loss, expense or damage occasioned by the use of this report. Only the Client is authorized to permit copying or distribution of this report and then only in its entirety. Any use of the Intertek name or one of its marks for the sale or advertisement of the tested material, product or service must first be approved in writing by Intertek. The observations and test results in this report are relevant only to the sample tested. This report by itself does not imply that the material, product, or service is or has ever been under an Intertek certification program.

© 2017 Intertek

TEST REPORT

GENERAL INFORMATION

Grantee:	Musical Electronics Ltd.
Grantee Address:	Flat H, J, K, 12/F., World Tech Centre, 95 How Ming Street, Kwun Tong, Kowloon, Hong Kong
Contact Person:	Richard Leung
Tel:	(852) 2372 1171
Fax:	2341 9964
e-mail:	MKT@musical.com.hk
Trade Name:	circuit CUBES
Model:	11111-00000
Additional Model:	11131-00000
Type of EUT:	Transceiver
Description of EUT:	STEM Educational Toys
Serial Number:	N/A
FCC ID:	AUI-TBT01A
Date of Sample Submitted:	June 23, 2020
Date of Test:	June 23, 2020 to July 22, 2020
Report No.:	20061339HKG-001
Report Date:	November 27, 2020
Environmental Conditions:	Temperature: +10 to 40°C Humidity: 10 to 90%
Conclusion:	Test was conducted by client submitted sample. The submitted sample as received complied with the 47 CFR Part 15 Certification.

TEST REPORT

SUMMARY OF TEST RESULT

Test Specification	Reference	Results
Radiated Emission	15.249, 15.209	Pass
Radiated Emission on the Bandedge		
Radiated Emission in Restricted Bands	15.205	Pass

The equipment under test is found to be complying with the following standards:
FCC Part 15, October 1, 2019 Edition

- Note:
1. The EUT uses a permanently attached antenna which, in accordance to section 15.203, is considered sufficient to comply with the provisions of this section.
 2. Pursuant to FCC part 15 Section 15.215(c), the 20 dB bandwidth of the emission was contained within the frequency band designated (mentioned as above) which the EUT operated. The effects, if any, from frequency sweeping, frequency hopping, other modulation techniques and frequency stability over expected variations in temperature and supply voltage were considered.

TEST REPORT

TABLE OF CONTENTS

1.0	GENERAL DESCRIPTION	5
1.1	Product Description	5
1.2	Related Submittal(s) Grants	5
1.3	Test Methodology.....	5
1.4	Test Facility	5
2.0	SYSTEM TEST CONFIGURATION.....	6
2.1	Justification.....	6
2.2	EUT Exercising Software.....	6
2.3	Special Accessories	6
2.4	Measurement Uncertainty.....	6
2.5	Support Equipment List and Description.....	6
3.0	EMISSION RESULTS.....	7
3.1	Field Strength Calculation	7
3.2	Radiated Emission Configuration Photograph.....	8
3.3	Radiated Emission Data	8
4.0	EQUIPMENT PHOTOGRAPHS	13
5.0	PRODUCT LABELLING.....	13
6.0	TECHNICAL SPECIFICATIONS	13
7.0	INSTRUCTION MANUAL.....	13
8.0	MISCELLANEOUS INFORMATION	14
8.1	Radiated Emission on the Bandedge.....	14
8.2	Discussion of Pulse Desensitization.....	17
8.3	Calculation of Average Factor	17
8.4	Emissions Test Procedures.....	18
9.0	EQUIPMENT LIST.....	21

TEST REPORT

1.0 GENERAL DESCRIPTION

1.1 Product Description

The Equipment Under Test (EUT) is STEM Educational Toys. The EUT has Bluetooth BLE feature. It is powered by a 3.7V internal rechargeable battery.

The Model: 11131-00000 is the same as the Model: 11111-00000 in electronics/electrical designs including software & firmware, PCB layout and construction design/physical design/enclosure as declared by client. The only differences between these models are model number, color and cosmetic details to be sold for marketing purpose as declared by client.

Antenna Type: Internal, Integral

For electronic filing, the brief circuit description is saved with filename: descri.pdf.

1.2 Related Submittal(s) Grants

This is a single application for certification of a transceiver.

1.3 Test Methodology

Radiated emission measurements were performed according to the procedures in ANSI C63.10 (2013). All radiated measurements were performed in an 3m Chamber. Preliminary scans were performed in the 3m Chamber only to determine worst case modes. All radiated tests were performed at an antenna to EUT distance of 3 meters, unless stated otherwise in the “**Justification Section**” of this Application.

1.4 Test Facility

The 3m Chamber used to collect the radiated data is located at Workshop No. 3, G/F., World-Wide Industrial Centre, 43-47 Shan Mei Street, Fo Tan, Sha Tin, N.T., Hong Kong SAR, China. This test facility and site measurement data have been placed on file with the FCC.

TEST REPORT

2.0 SYSTEM TEST CONFIGURATION

2.1 Justification

The system was configured for testing in a typical fashion (as a customer would normally use it), and in the confines as outlined in ANSI C63.10 (2013).

The device was powered by DC 3.7V (1 x 3.7V fully charged internal rechargeable battery).

For maximizing emissions, the EUT was rotated through 360°, the antenna height was varied from 1 meter to 4 meters above the ground plane, and the antenna polarization was changed. This step by step procedure for maximizing emissions led to the data reported in Exhibit 3.0.

The unit was operated standalone and placed in the centre of the turntable.

The equipment under test (EUT) was configured for testing in a typical fashion (as a customer would normally use it). The EUT was mounted to a plastic stand if necessary and placed on the wooden turntable, which enabled the engineer to maximize emissions through its placement in the three orthogonal axes.

2.2 EUT Exercising Software

The EUT exercise program (if any) used during radiated and conducted testing was designed to exercise the various system components in a manner similar to a typical use.

2.3 Special Accessories

There are no special accessories necessary for compliance of this product.

2.4 Measurement Uncertainty

Decision Rule for compliance: For FCC/IC standard, the measured value must be within the limits of applicable standard without accounting for the measurement uncertainty. For EN/IEC/HKTA/HKTC standard, conformity rules will be used as per standard directly excepted EN/IEC 61000-3-2, EN/IEC 61000-3-3, HKTA1004, HKCA1008, HKTA1019, HKTA1020, HKTA1041 and HKTA1044. For these excepted or not mentioned standards, Cl 4.2.2 of ILAC-G8:09/2019 decision rules will be reference and guard band will be equal to our measurement uncertainty with 95% confidence level ($k=2$). In case, the measured value is within guard band region, undetermined decision will be used.

Uncertainty and Compliance - Unless the standard specifically states that measured values are to be extended by the measurement uncertainty in determining compliance, all compliance determinations are based on the actual measured value.

2.5 Support Equipment List and Description

1. 2 x motor module
2. 1 x LED module
(Provided by Applicant)

TEST REPORT

3.0 EMISSION RESULTS

Data is included of the worst-case configuration (the configuration which resulted in the highest emission levels). A sample calculation, configuration photographs and data tables of the emissions are included.

3.1 Field Strength Calculation

The field strength is calculated by adding the Antenna Factor and Cable Factor, and subtracting the Amplifier Gain (if any), Average Factor (optional) from the measured reading. The basic equation with a sample calculation is as follows:

$$FS = RA + AF + CF - AG - AV$$

where FS = Field Strength in dB μ V/m

RA = Receiver Amplitude (including preamplifier) in dB μ V

CF = Cable Attenuation Factor in dB

AF = Antenna Factor in dB

AG = Amplifier Gain in dB

AV = Average Factor in dB

In the following table(s), the reading shown on the data table reflects the preamplifier gain. An example for the calculations in the following table is as follows:

$$FS = RR + LF$$

where FS = Field Strength in dB μ V/m

RR = RA - AG - AV in dB μ V

LF = CF + AF in dB

Assume a receiver reading of 52.0 dB μ V is obtained. The antenna factor of 7.4 dB and cable factor of 1.6 dB are added. The amplifier gain of 29 dB and average factor of 5 dB are subtracted, giving a field strength of 27 dB μ V/m. This value in dB μ V/m was converted to its corresponding level in μ V/m.

$$RA = 52.0 \text{ dB}\mu\text{V/m}$$

$$AF = 7.4 \text{ dB}$$

$$CF = 1.6 \text{ dB}$$

$$AG = 29.0 \text{ dB}$$

$$AV = 5.0 \text{ dB}$$

$$FS = RR + LF$$

$$FS = 18 + 9 = 27 \text{ dB}\mu\text{V/m}$$

$$RR = 18.0 \text{ dB}\mu\text{V}$$

$$LF = 9.0 \text{ dB}$$

$$\text{Level in } \mu\text{V/m} = \text{Common Antilogarithm } [(27 \text{ dB}\mu\text{V/m})/20] = 22.4 \mu\text{V/m}$$

TEST REPORT

3.2 Radiated Emission Configuration Photograph

The worst case in radiated emission was found at 7206 MHz

For electronic filing, the worst-case radiated emission configuration photographs are saved with filename: radiated photos.pdf.

3.3 Radiated Emission Data

The data on the following page lists the significant emission frequencies, the limit and the margin of compliance. Numbers with a minus sign are below the limit.

Judgment: Passed by 4.5 dB

TEST REPORT

RADIATED EMISSIONS

Model: 11111-00000

Date of Test: July 22, 2020

Worst-Case Operating Mode: Transmitting

Table 1
Pursuant to FCC Part 15 Section 15.249 Requirement

Lowest Channel

Polarization	Frequency (MHz)	Reading (dBµV)	Pre-Amp Gain (dB)	Antenna Factor (dB)	Net at 3m - Average (dBµV/m)	Average Limit at 3m (dBµV/m)	Margin (dB)
V	2402.000	88.0	33	29.4	84.4	94.0	-9.6
V	4804.000	35.9	33	34.9	37.8	54.0	-16.2
H	7206.000	44.6	33	37.9	49.5	54.0	-4.5
H	9608.000	37.0	33	40.4	44.4	54.0	-9.6
H	12010.000	27.3	33	40.5	34.8	54.0	-19.2
H	14412.000	30.2	33	40.0	37.2	54.0	-16.8

Polarization	Frequency (MHz)	Reading (dBµV)	Pre-Amp Gain (dB)	Antenna Factor (dB)	Net at 3m - Peak (dBµV/m)	Peak Limit at 3m (dBµV/m)	Margin (dB)
V	2402.000	94.6	33	29.4	91.0	114.0	-23.0
V	4804.000	44.6	33	34.9	46.5	74.0	-27.5
H	7206.000	50.3	33	37.9	55.2	74.0	-18.8
H	9608.000	44.6	33	40.4	52.0	74.0	-22.0
H	12010.000	40.5	33	40.5	48.0	74.0	-26.0
H	14412.000	43.2	33	40.0	50.2	74.0	-23.8

- NOTES: 1. Peak Detector Data unless otherwise stated. Average measurement is according to ANSI C63.10 (2013).
2. All measurements were made at 3 meters.
3. Negative sign in the column shows value below limit.
4. Horn antenna is used for the emission over 1000MHz.
5. Emission (the row indicated by **bold italic**) within the restricted band meets the requirement of FCC Part 15 Section 15.205.
6. Measurement Uncertainty is ±5.3dB at a level of confidence of 95%.

TEST REPORT

Model: 11111-00000
Date of Test: July 22, 2020
Worst-Case Operating Mode: Transmitting

Table 2
Pursuant to FCC Part 15 Section 15.249 Requirement

Middle Channel

Polarization	Frequency (MHz)	Reading (dBµV)	Pre-Amp Gain (dB)	Antenna Factor (dB)	Net at 3m - Average (dBµV/m)	Average Limit at 3m (dBµV/m)	Margin (dB)
V	2440.000	87.8	33	29.4	84.2	94.0	-9.8
H	4880.000	38.1	33	34.9	40.0	54.0	-14.0
V	7320.000	39.3	33	37.9	44.2	54.0	-9.8
V	9760.000	32.1	33	40.4	39.5	54.0	-14.5
H	12200.000	27.0	33	40.5	34.5	54.0	-19.5
V	14640.000	32.0	33	38.4	37.4	54.0	-16.6

Polarization	Frequency (MHz)	Reading (dBµV)	Pre-Amp Gain (dB)	Antenna Factor (dB)	Net at 3m - Peak (dBµV/m)	Peak Limit at 3m (dBµV/m)	Margin (dB)
V	2440.000	94.8	33	29.4	91.2	114.0	-22.8
H	4880.000	46.1	33	34.9	48.0	74.0	-26.0
V	7320.000	47.7	33	37.9	52.6	74.0	-21.4
V	9760.000	41.2	33	40.4	48.6	74.0	-25.4
H	12200.000	40.7	33	40.5	48.2	74.0	-25.8
V	14640.000	45.4	33	38.4	50.8	74.0	-23.2

- NOTES: 1. Peak Detector Data unless otherwise stated. Average measurement is according to ANSI C63.10 (2013).
2. All measurements were made at 3 meters.
3. Negative sign in the column shows value below limit.
4. Horn antenna is used for the emission over 1000MHz.
5. Emission (the row indicated by **bold italic**) within the restricted band meets the requirement of FCC Part 15 Section 15.205.
6. Measurement Uncertainty is ±5.3dB at a level of confidence of 95%.

TEST REPORT

Model: 11111-00000

Date of Test: July 22, 2020

Worst-Case Operating Mode: Transmitting

Table 3
Pursuant to FCC Part 15 Section 15.249 Requirement

Highest Channel

Polarization	Frequency (MHz)	Reading (dBµV)	Pre-Amp Gain (dB)	Antenna Factor (dB)	Net at 3m - Average (dBµV/m)	Average Limit at 3m (dBµV/m)	Margin (dB)
H	2480.000	88.8	33	29.4	85.2	94.0	-8.8
V	4960.000	39.3	33	34.9	41.2	54.0	-12.8
H	7440.000	33.3	33	37.9	38.2	54.0	-15.8
V	9920.000	25.4	33	40.4	32.8	54.0	-21.2
H	12400.000	26.1	33	40.5	33.6	54.0	-20.4
V	14880.000	31.0	33	38.4	36.4	54.0	-17.6

Polarization	Frequency (MHz)	Reading (dBµV)	Pre-Amp Gain (dB)	Antenna Factor (dB)	Net at 3m - Peak (dBµV/m)	Peak Limit at 3m (dBµV/m)	Margin (dB)
H	2480.000	95.2	33	29.4	91.6	114.0	-22.4
V	4960.000	46.3	33	34.9	48.2	74.0	-25.8
H	7440.000	42.7	33	37.9	47.6	74.0	-26.4
V	9920.000	41.8	33	40.4	49.2	74.0	-24.8
H	12400.000	39.9	33	40.5	47.4	74.0	-26.6
V	14880.000	44.6	33	38.4	50.0	74.0	-24.0

- NOTES: 1. Peak Detector Data unless otherwise stated. Average measurement is according to ANSI C63.10 (2013).
2. All measurements were made at 3 meters.
3. Negative sign in the column shows value below limit.
4. Horn antenna is used for the emission over 1000MHz.
5. Emission (the row indicated by **bold italic**) within the restricted band meets the requirement of FCC Part 15 Section 15.205.
6. Measurement Uncertainty is ±5.3dB at a level of confidence of 95%.

TEST REPORT

Model: 11111-00000

Date of Test: July 22, 2020

Worst-Case Operating Mode: Bluetooth Searching

Table 4
Pursuant to FCC Part 15 Section 15.209 Requirement

Polarization	Frequency (MHz)	Reading (dBµV)	Pre-amp (dB)	Antenna Factor (dB)	Net at 3m (dBµV/m)	Limit at 3m (dBµV/m)	Margin (dB)
V	95.932	17.5	16	12.0	13.5	43.5	-30.0
V	112.750	25.4	16	14.0	23.4	43.5	-20.1
V	119.210	21.4	16	14.0	19.4	43.5	-24.1
V	131.642	26.5	16	14.0	24.5	43.5	-19.0
H	150.654	23.4	16	14.0	21.4	43.5	-22.1
V	224.144	21.4	16	18.0	23.4	46.0	-22.6

- NOTES:
1. Quasi-Peak Detector Data unless otherwise stated.
 2. All measurements were made at 3 meters.
 3. Negative sign in the column shows value below limit.
 4. Horn antenna is used for the emission over 1000MHz.
 5. Emission (the row indicated by **bold italic**) within the restricted band meets the requirement of FCC Part 15 Section 15.205.
 6. Measurement Uncertainty is ±5.3dB at a level of confidence of 95%.

TEST REPORT

4.0 EQUIPMENT PHOTOGRAPHS

For electronic filing, the photographs are saved with filename: external photos.pdf and internal photos.pdf.

5.0 PRODUCT LABELLING

For electronics filing, the FCC ID label artwork and the label location are saved with filename: label.pdf.

6.0 TECHNICAL SPECIFICATIONS

For electronic filing, the block diagram and schematic of the tested EUT are saved with filename: block.pdf and circuit.pdf respectively.

7.0 INSTRUCTION MANUAL

For electronic filing, a preliminary copy of the Instruction Manual is saved with filename: manual.pdf.

This manual will be provided to the end-user with each unit sold/leased in the United States.

TEST REPORT

8.0 MISCELLANEOUS INFORMATION

The miscellaneous information includes details of the test procedure and measured bandwidth / calculation of factor such as pulse desensitization and averaging factor (calculation and timing diagram).

8.1 Radiated Emission on the Bandedge

From the following plots, they show that the fundamental emissions are confined in the specified band (2400MHz to 2483.5MHz). In case of the fundamental emissions are within two standard bandwidths from the bandedge, the delta measurement technique is used for determining bandedge compliance. Standard bandwidth is the bandwidth specified by ANSI C63.10 (2013) for frequency being measured.

Emissions radiated outside of the specified frequency bands, except harmonics, are attenuated by 50dB below the level of the fundamental or to the general radiated emissions limits in Section 15.209, whichever is the lesser attenuation, which meet the requirement of part 15.249(d).

TEST REPORT

PEAK MEASUREMENT

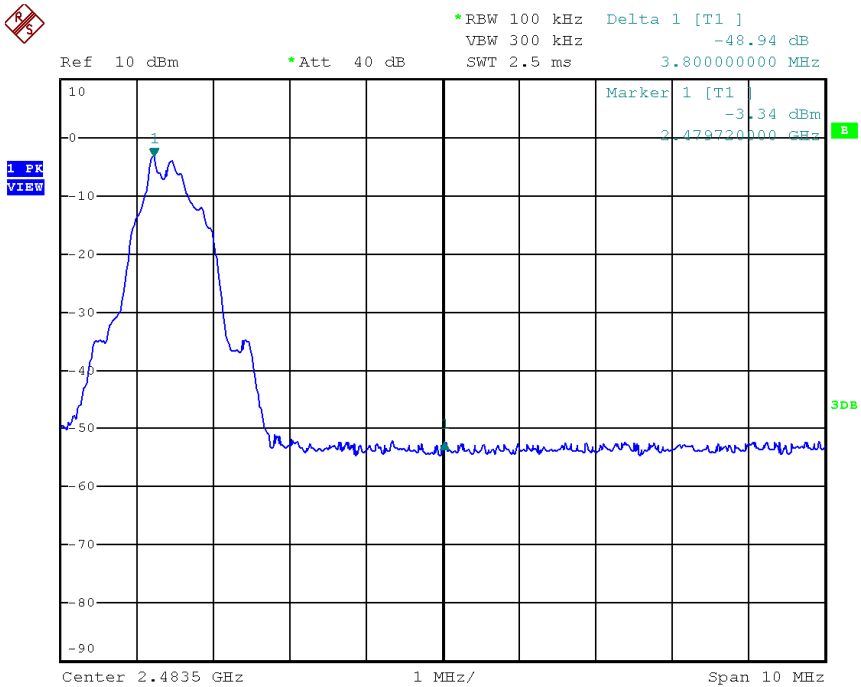
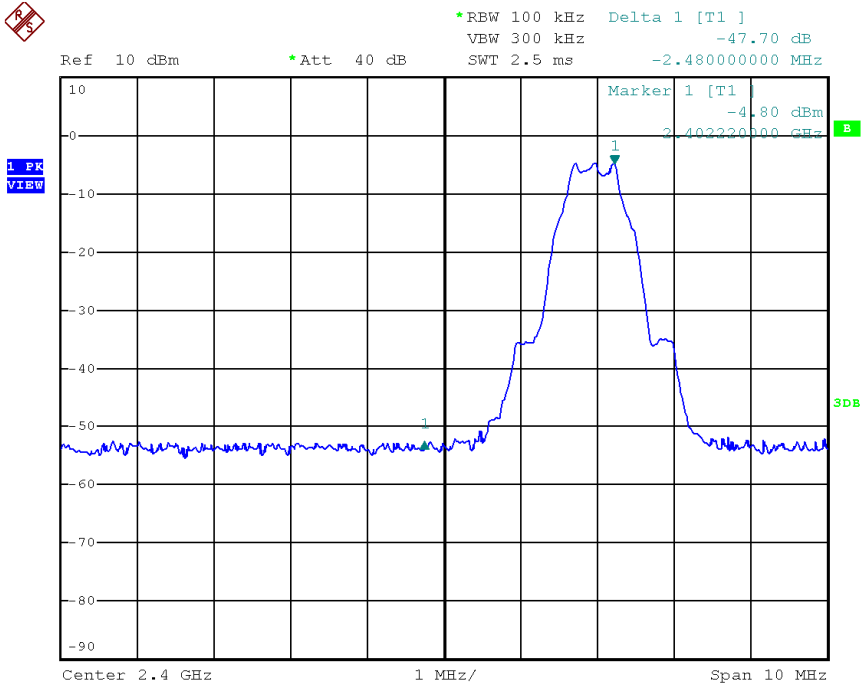

TEST REPORT

PEAK MEASUREMENT

Bandedge compliance is determined by applying marker-delta method, i.e. (Bandedge Plot).

Lower bandedge

Peak Resultant field strength = Fundamental emissions (peak value) – delta from the plot

=91.0 dB μ V/m – 47.7 dB

=43.3 dB μ V/m

Average Resultant field strength = Fundamental emissions (average value) – delta from the plot

=84.4 dB μ V/m – 47.7 dB

=36.7 dB μ V/m

Upper bandedge

Peak Resultant field strength = Fundamental emissions (peak value) – delta from the plot

=91.6 dB μ V/m – 48.9 dB

=42.7 dB μ V/m

Average Resultant field strength = Fundamental emissions (average value) – delta from the plot

=85.2 dB μ V/m – 48.9 dB

=36.3 dB μ V/m

The resultant field strength meets the general radiated emission limit in Section 15.209, which does not exceed 74 dB μ V/m (Peak Limit) and 54 dB μ V/m (Average Limit).

TEST REPORT

8.2 Discussion of Pulse Desensitization

Pulse desensitivity is not applicable for this device. The effective period (T_{eff}) is approximately $100\mu s$ for a digital "1" bit which illustrated on technical specification, with a resolution bandwidth (3dB) of 3MHz, so the pulse desensitivity factor is 0dB.

8.3 Calculation of Average Factor

The average factor is not applicable for this device as the transmitted signal is a continuously signal.

TEST REPORT

8.4 Emissions Test Procedures

The following is a description of the test procedure used by Intertek Testing Services Hong Kong Ltd. in the measurements of transmitter operating under the Part 15, Subpart C rules.

The transmitting equipment under test (EUT) is placed on a wooden turntable which is four feet in diameter and approximately 0.8m in height above the ground plane for emission measurement at or below 1GHz and 1.5m in height above the ground plane for emission measurement above 1GHz. During the radiated emissions test, the turntable is rotated and any cables leaving the EUT are manipulated to find the configuration resulting in maximum emissions. The EUT is adjusted through all three orthogonal axis to obtain maximum emission levels. The antenna height and polarization are also varied during the testing to search for maximum signal levels. The height of the antenna is varied from one to four meters.

Detector function for radiated emissions is in peak mode. Average readings, when required, are taken by measuring the duty cycle of the equipment under test and subtracting the corresponding amount in dB from the measured peak readings. A detailed description for the calculation of the average factor can be found in Exhibit 8.3.

The frequency range scanned is from the lowest radio frequency signal generated in the device which is greater than 9 kHz to the tenth harmonic of the highest fundamental frequency or 40 GHz, whichever is lower.

TEST REPORT

8.4 Emissions Test Procedures (cont'd)

The EUT is warmed up for 15 minutes prior to the test.

AC power to the unit is varied from 85% to 115% nominal and variation in the fundamental emission field strength is recorded. If battery powered, a new, fully charged battery is used.

Conducted measurements were made as described in ANSI C63.10 (2013).

The IF bandwidth used for measurement of radiated signal strength was 100 kHz or greater when frequency is below 1000 MHz. Where pulsed transmissions of short enough pulse duration warrant, a greater bandwidth is selected according to the recommendations of Hewlett Packard Application Note 150-2. A discussion of whether pulse desensitivity is applicable to this unit is included in this report (See Exhibit 8.1). Above 1000 MHz, a resolution bandwidth of 3 MHz is used.

Transmitter measurements are normally conducted at a measurement distance of three meters. However, to assure low enough noise floor in the forbidden bands and above 1 GHz, signals are acquired at a distance of one meter or less. All measurements are extrapolated to three meters using inverse scaling, unless otherwise reported. Measurements taken at a closer distance are so marked.

TEST REPORT

8.4.1 Radiated Emission Test Setup

The figure below shows the test setup, which is utilized to make these measurements.

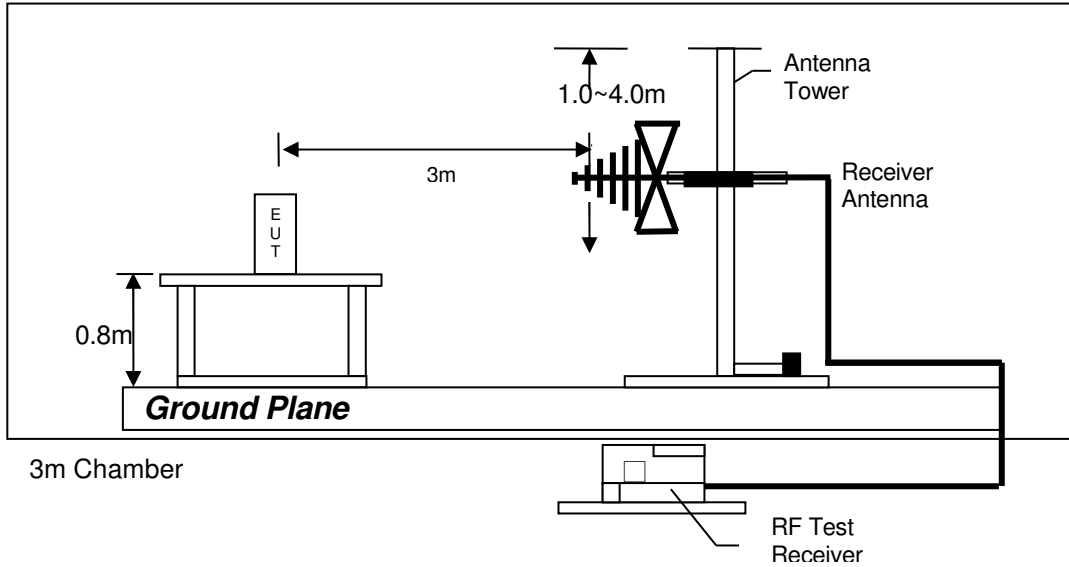

Test setup of radiated emissions up to 1GHz

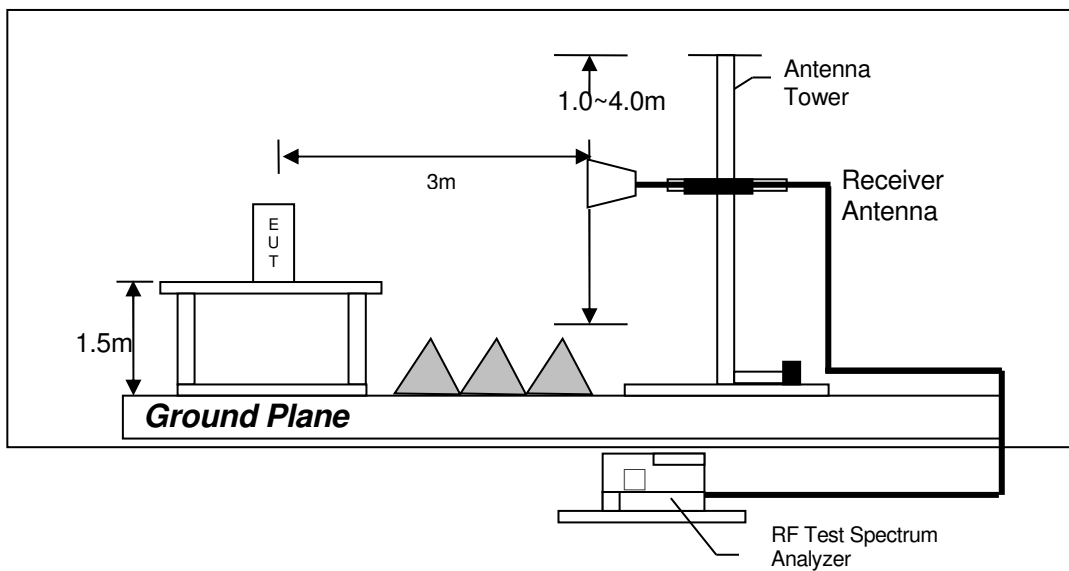

Test setup of radiated emissions above 1GHz

TEST REPORT

9.0 EQUIPMENT LIST

1) Radiated Emissions Test

Equipment	EMI Test Receiver	Spectrum Analyzer	Biconical Antenna
Registration No.	EW-3666	EW-2253	EW-0571
Manufacturer	R&S	ROHDESCHWARZ	EMCO
Model No.	ESCI7	FSP40	3104C
Calibration Date	August 28, 2019	18 Nov 2019	July 23, 2019
Calibration Due Date	August 28, 2020	18 Nov 2020	July 23, 2021

Equipment	Log Periodic Antenna	Double Ridged Guide Antenna	14m Double Shield RF Cable (20MHz - 6GHz)
Registration No.	EW-0447	EW-1015	EW-2528
Manufacturer	EMCO	EMCO	RADIALL
Model No.	3146	3115	Nm-RG142-
Calibration Date	September 25, 2019	16 May 2019	30 Sep 2019
Calibration Due Date	March 25, 2021	16 Nov 2020	30 Sep 2020

Equipment	Active Loop H-field (9kHz to 30MHz)	RF Preamp (9kHz to 6000MHz)	RF Cable 14m (1GHz to 26.5GHz)
Registration No.	EW-3326	EW-3006b	EW-3151
Manufacturer	EMCO	SCHWARZBECK	GREATBILLION
Model No.	6502	BBV9718	SMA m/SHF5MPU /SMA m ra14m,26G
Calibration Date	March 21, 2019	25 Nov 2019	March 04, 2020
Calibration Due Date	September 21, 2020	25 Nov 2020	March 04, 2021

Equipment	2.4GHz Notch Filter	Pyramidal Horn Antenna
Registration No.	EW-3435	EW-0905
Manufacturer	MICROWAVE	EMCO
Model No.	N0324413	3160-09
Calibration Date	16 Nov 2019	July 23, 2019
Calibration Due Date	16 Nov 2020	January 23, 2021

2) Bandedge Measurement

Equipment	RF Cable (up to 40GHz) 1.5m length	Spectrum Analyzer
Registration No.	EW-3104	EW-2253
Manufacturer	N/A	ROHDESCHWARZ
Model No.	SMA-M to SMA-M	FSP40
Calibration Date	August 26, 2019	18 Nov 2019
Calibration Due Date	August 26, 2020	18 Nov 2020

END OF TEST REPORT