

Universal Socket Connectivity

Embedded Device Networking Solutions

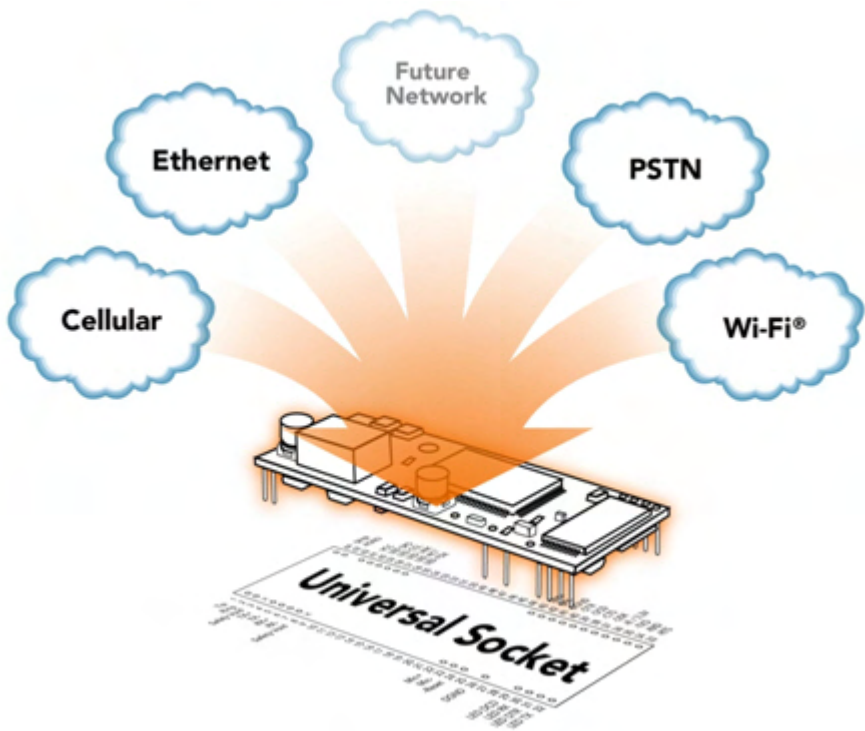

Hardware Guide for Developers

Universal Socket Connectivity**Hardware Guide for Developers, PN S000342M, Version M**

For the following products (The list indicates base models for each product. See each product chapter product build options):

Cellular SocketModems

- SocketModem® Cell – GPRS (MTSMC-G2, MTSMC-G2-V)
- SocketModem® iCell – GPRS (MTSMC-G2-IP, MTSMC-G2-GP)
- SocketModem® Cell – CDMA 1xRTT (MTSMC-C1, MTSMC-C1-V)
- SocketModem® iCell – CDMA 1xRTT (MTSMC-C1-IP, MTSMC-C1-GP)
- SocketModem® EDGE – (MTSMC-E1 and other build options)
- Socket Modem® Cell – HSPA (MTSMC-H4 – USB)
- Socket Modem® iCell – HSPA (MTSMC-H4 – IP and GP build options)
- Socket Modem® Cell – EV-DO (MTSMC-EV2 – USB)
- Socket Modem® iCell – EV-DO (MTSMC-EV2 – IP and GP build options)

Analog SocketModems

- SocketModem® – MT9234SMI and other build options
- SocketModem® – MT5692SMI and other build options
- SocketModem® – MT2492SMI and other build options

Embedded Device Servers

- SocketModem IP® – MT100SEM-IP and other build options
- SocketWireless® Wi-Fi® – MT810SWM-IP and other build options
- SocketWireless® Bluetooth® – MTS2BTSMI and other build options

Copyright

This publication may not be reproduced, in whole or in part, without prior expressed written permission from Multi-Tech Systems, Inc. All rights reserved.

Copyright © 2004-10 by Multi-Tech Systems, Inc.

Multi-Tech Systems, Inc. makes no representations or warranties with respect to the contents hereof and specifically disclaim any implied warranties of merchantability or fitness for any particular purpose. Furthermore, Multi-Tech Systems, Inc. reserves the right to revise this publication and to make changes from time to time in the content hereof without obligation of Multi-Tech Systems, Inc. to notify any person or organization of such revisions or changes.

Trademarks

Trademarks and Registered Trademarks of Multi-Tech Systems, Inc. are **SocketModem**, **SocketWireless**, **SocketEthernet IP**, and the Multi-Tech logo.

Microsoft and **Windows** are trademarks or registered trademarks of Microsoft Corporation in the United States and other countries. **Bluetooth** is a registered trademark of the Bluetooth SIG, Inc. **Wi-Fi** is a registered trademark of the Wi-Fi Alliance.

Contacting Multi-Tech Support

Multi-Tech Online Support Portal <https://support.multitech.com>

In order to better serve our customers, manage support requests and shorten resolution times, we have created the online web portal allowing you to submit questions regarding Multi-Tech products directly to our technical support team. Get answers to your most complex questions, ranging from implementation, troubleshooting, product configuration, firmware upgrades and much more.

To create an account and submit a Support Case on the Portal, visit <https://support.multitech.com>

Knowledge Base and Support Services: <https://www.multitech.com/support.go>

The Knowledge Base provides immediate answers to your questions and gives you access to support resolutions for all Multi-Tech products. Visit our support area on the website for other support services.

Technical Support**Country**

Europe, Middle East, Africa:
U.S., Canada, all others:

By Email

support@multitech.co.uk
support@multitech.com

By Phone

+(44) 118 959 7774
(800) 972-2439 or (763) 717-5863

Warranty

Warranty information can found at: <http://www.multitech.com/warranty.go>

World Headquarters

Multi-Tech Systems, Inc.
2205 Woodale Drive
Mounds View, Minnesota 55112
Phone: 763-785-3500 or 800-328-9717; Fax: 763-785-9874
Internet Address: <http://www.multitech.com>

Revision Notes

Rev.	Date	Description
J.2	07/30/09	<ul style="list-style-type: none"> Updated Mechanical Drawings for SocketModem Cell & iCell (MTSMC-G2 & G2-IP) Changed the title of two Mechanical Drawings in Chapter 1
J.3	08/28/09	<ul style="list-style-type: none"> Updated Mechanical Drawings for SocketModem GPRS (MTSMC-G2) Added new Mechanical Drawings for SocketModem CDMA (MTSMC-C) & HSDPA MTSMC-H
J.4	10/15/09	<ul style="list-style-type: none"> Added GPS section to G2 chapter (added the power draw table for G2 for GPS) Brought back the chapter covering the SocketModem MT2456SMI-22.
K	11/18/09	<ul style="list-style-type: none"> New chapters for new products: SocketModem MT5692SMI, Device Server MT810SWM-IP, and SocketModem EDGE (MTSMC-E1) Deleted chapters SocketModem MT5656SMI, MT5656SMI-IP, and MT2456SMI-22 Added Sleep Mode Power Draw statistics for the SocketModem MT9234SMI Added new Mechanical Drawings for SocketModem HSDPA and SocketModem CDMA Updated the Power Requirements for the MT2492SMI and MT5692SMI (10/16/09) Added GPS to SocketModem Cell/SocketModem iCell (MTSMC-G2) and GPS power draw Reorganized Chapter 1 – general information, cellular information, and analog information. Added Japan's Standards statement Updated Mechanical Drawings in Chapter 1 New Developer Board Block Diagram with antenna system added
L	03/12/10	<ul style="list-style-type: none"> Added new CDMA-C1 chapter (replaces CDMA chapter) Added Multi-Tech Technical Support using the Web Portal (see Copyright & Tech Support page) Updated Universal Developer Kit contents Added CDMA Specifications in Chapter 1 Added Mag Mount Dual Band antennas and GPS antennas available from Multi-Tech Added Mechanical Drawings: MT9234SMI, MT5692SMI, MT2492SMI, MT100SEM-IP, Bluetooth Updated G2-GP power draw statistics Updated the LED Interface Signals for G2 Removed Loopback test references from MT9234SMI and MT5692SMI chapters Added Important note about Tooling Holes and Mounting Hardware Moved the CDMA Terminology and Acronyms chapter the CDMA AT Commands manual Moved the GPS section into Chapter 1 Removed "Features" from Technical Specifications Enhanced the Antenna Section in Chapter 1 Updated Bluetooth power draw statistics
L.1	03/19/10 04/15/10	<p>Changed three C1 Mechanical Drawings (-V, -IP, -GP)</p> <p>Added a note in Chapter 1 that not all products include all pins as shown in the Chapter 1 graphic and users should see the specific mechanical drawings for each product.</p>
M	07/20/10	<ul style="list-style-type: none"> New products: SocketModem® Cell & iCell HSPA and SocketModem® Cell & iCell – EV-DO In Chapter 1, removed the sentence "In the command state, the modem ignores –RTS" under the description of the –RTS pin In Chapter 1, removed the bulleted point from the "Maintenance of Your Cellular Device" section which suggested that the device not be exposed to temperatures above a certain limit. Temperature is covered in each product's technical specifications In Chapter 1, for Telecom Approvals for Analog Modems updated the link to the Web site and deleted the table that listed the country approvals since the Web site is always updated Added baud rate switches to CDMA-C1 product In the MT9234SMI specs table, changed Modes of Operation text from "full duplex over dial-up" to "full duplex over dial-up or 2-wire leased lines" In the MT9234SMI specification table, removed the power measurements (they appear in their own section) Changed the Mechanical Drawings for MT5693SMI-P and MT9234SMI-P Added parallel pin descriptions for MT5693SMI-P and MT9234SMI-P Updated some MT5693SMI-P and MT9234SMI-P parallel information Updated the Power Measurements for MT2492SMI Changed the operating temperature for MT100SEM-IP from 0° C – +70° C to -40° C to +85° C Added LED Interface section to MT100SEM-IP Updated LED Interface section in MT810SWM-IP chapter Updated the Power Measurements for the MT2492SMI

Table of Contents

Part 1 Universal Socket Connectivity	9
Chapter 1 – Universal Socket Connectivity	10
Multi-Tech Embedded Solutions	10
Universal Socket Connectivity Features.....	10
The Universal Socket Design.....	10
Universal Developer Kit Contents.....	11
AT Commands for All Embedded Products Are Included on the Developer Kit CD.....	11
Universal Socket Pin Out	12
Universal Pin Descriptions.....	12
Design Considerations	16
Noise Suppression Design Considerations.....	16
PC Board Layout Guidelines.....	16
MTSMC Tooling Holes and Mounting Hardware.....	16
Electromagnetic Interference (EMI) Considerations.....	17
Electrostatic Discharge Control.....	17
Phone Line Warning Statement for the Developer Board.....	17
SocketModem Developer Board	18
Board Components.....	19
Jumpers and Corresponding Signals.....	19
SocketModem Developer Board Block Diagram.....	20
Developer Board Schematics.....	21
Developer Board Schematics.....	22
Developer Board Schematics.....	23
Developer Board Schematics.....	24
Developer Board Schematics.....	25
Upgrading Firmware	26
XMODEM Serial Port for Firmware Upgrade.....	27
Multi-Tech Systems, Inc. Flash Programming Protocol.....	28
Cellular Information	31
Antenna System for Cellular Devices.....	31
FCC Requirements for the Antenna.....	31
Antenna Specifications.....	31
Coax Cables Specifications.....	34
Global Positioning System (GPS).....	37
Account Activation for Cellular Devices.....	38
Cellular Approvals and Labeling Requirements.....	38
Analog Information	40
Recommended Parts for Analog SocketModems.....	40
Analog Labeling Requirements.....	41
Safety Notices and Warnings	44
Cellular Safety.....	44
Analog Telecom Safety Warnings.....	45
Telecom Approvals for Analog Modems.....	46
Regulatory Compliance Statements	47
Country/Region-Specific Statements.....	47
Waste Electrical and Electronic Equipment Statement.....	52
Restriction of the Use of Hazardous Substances (RoHS).....	53
Information on HS/TS Substances According to Chinese Standards in English.....	54
Information on HS/TS Substances According to Chinese Standards in Chinese.....	55
Part 2 Cellular SocketModems	56
Chapter 2 – SocketModem® Cell & SocketModem® iCell GPRS (MTSMC-G2)	57
Introduction.....	57
Product Build Options and Ordering Information	57
AT Commands Reference Guides	57

Technical Specifications	58
MTSMC Tooling Holes and Mounting Hardware	59
Mechanical Drawings – Basic Build	60
Mechanical Drawings – Voice Build	61
Mechanical Drawings – IP Build	62
Mechanical Drawings – GPS Build	63
DC Electrical Characteristics	64
Power Measurements	64
Application Notes	65
LED Interface.....	65
RF Performances	65
RF Connection and Antenna	65
Microphone Inputs	65
Changing the Quad Band	66
Chapter 3 – SocketModem® Cell and SocketModem iCell CDMA 1xRTT (MTSMC-C1)	67
Introduction	67
Product Build Options and Ordering Information	67
AT Commands Reference Guides	68
Technical Specifications	69
MTSMC Tooling Holes and Mounting Hardware	70
Mechanical Drawings – Basic Build	71
Mechanical Drawings – Voice Build	72
Mechanical Drawings – IP Build	73
Mechanical Drawings – GPS Build	74
DC Electrical Characteristics	75
Power Measurements	75
Application Notes	76
LED Interface.....	76
RF Interface.....	76
RF Connection and Antenna	76
Baud Rate Switches on the SocketModem iCell.....	77
Chapter 4 – SocketModem® EDGE (MTSMC-E1)	78
Introduction	78
Product Build Options and Ordering Information	78
AT Commands Reference Guide	78
Technical Specifications	79
Mechanical Drawings – Basic Build	80
Mechanical Drawings – Voice Build	81
DC Electrical Characteristics	82
Power Measurements	82
Application Notes	83
RF Performances	83
RF Connection and Antenna	83
Audio Interface – Electrical Characteristics	83
Microphone Inputs	83
Chapter 5 – SocketModem® iCell – HSPA (MTSMC-H4)	84
Introduction	84
Product Build Options and Ordering Information	84
AT Commands Reference Guide	84
Technical Specifications	85
MTSMC Tooling Holes and Mounting Hardware	86
Mechanical Drawings – Basic and IP Builds	87
Mechanical Drawings – USB Build	87
DC Electrical Characteristics	88

Electrical Specifications	88
Pin-Out Specifications	89
Power Measurements	90
Application Notes	91
LED Interface.....	91
RF Performances	91
Frequency Bands Supported.....	92
RF Connection and Antenna	92
Configuring the HSPA Modem on Linux SLAX 6.....	93
Baud Rate Switches on the SocketModem iCell.....	94
Chapter 6 – SocketModem iCell – EV-DO (MTSMC-EV2)	95
Introduction.....	95
Product Build Options and Ordering Information.....	95
AT Commands Reference Guide.....	96
Technical Specifications.....	97
MTSMC Tooling Holes and Mounting Hardware	98
Mechanical Drawings – Basic Build.....	99
Mechanical Drawings – IP Build.....	99
Mechanical Drawings – GPS Build.....	99
DC Electrical Characteristics.....	100
Electrical Specifications	100
Absolute Maximum Rating:	100
Pin-Out Specifications	101
Power Measurements.....	102
Application Notes	103
LED Interface.....	103
RF Interface.....	103
RF Connection and Antenna	103
Baud Rate Switches on the SocketModem iCell.....	104
Part 3 Analog SocketModems	105
Chapter 7 – SocketModem® (MT9234SMI)	106
Introduction.....	106
Product Build Options and Ordering Information.....	106
AT Commands Reference Guide.....	106
Technical Specifications.....	107
Mechanical Drawings – Basic and HV Builds	108
Mechanical Drawings – Parallel Builds.....	109
DC Electrical Characteristics.....	110
Power Measurements.....	111
Parallel Timing Requirements	112
Pin Descriptions for a Parallel SocketModem Device	113
SocketModem Parallel Interface Internal Registers.....	114
Application Notes	120
Tip and Ring Interface	120
Chapter 8 – SocketModem® (MT5692SMI)	121
Introduction.....	121
Product Build Options and Ordering Information.....	121
AT Commands Reference Guide.....	122
Technical Specifications.....	123
Mechanical Drawings – Basic Builds.....	124
Mechanical Drawings – IP Builds	125
Mechanical Drawings – No LEDS 3.3V Builds.....	126
Mechanical Drawings – Voice Builds.....	127
Mechanical Drawings – Parallel Builds.....	128

Operating Conditions	129
Absolute Maximum Rating.....	129
DC Electrical Characteristics.....	129
Power Measurements	130
Parallel Host Bus Timing Table	131
Pin Descriptions for a Parallel SocketModem Device	132
SocketModem Parallel Interface.....	133
Register Functional Definitions.....	134
Application Notes	143
Tip and Ring Interface	143
Microphone and Speaker	144
Chapter 9 – SocketModem® (MT2492SMI)	146
Introduction.....	146
Product Build Options and Ordering Information.....	146
AT Commands Reference Guide	146
Technical Specifications.....	147
Mechanical Drawings – All Builds.....	148
DC Electrical Characteristics.....	149
Power Measurements	149
Application Notes	150
Tip and Ring Interface	150
Part 4 Embedded Device Servers	151
Chapter 10 – SocketEthernet IP® (MT100SEM-IP).....	152
Introduction.....	152
Product Build Options and Ordering Information.....	152
AT Commands Reference Guide	152
Technical Specifications.....	153
Mechanical Drawings – All Builds.....	154
DC Electrical Characteristics.....	155
Power Measurements	155
Application Notes	156
LED Interface.....	156
Ethernet Interface – Non-Isolated Design.....	156
Ethernet Interface – Isolated Design	156
Recommended Parts.....	157
The Windows-Based Auto-Discovery Manager	158
Chapter 11 – SocketWireless® Wi-Fi® (MT810SWM-IP)	160
Introduction.....	160
Product Build Options and Ordering Information.....	160
AT Commands Reference Guide	160
Technical Specifications.....	161
Mechanical Drawings – Basic Build.....	162
Mechanical Drawings – 3.3V Build	163
Operating Conditions	164
Absolute Maximum Rating.....	164
DC Electrical Characteristics.....	164
Power Measurements	164
Application Notes	165
LED Interface.....	165
Default Power Up Settings	165
Regulatory Requirements for the Wi-Fi Antenna	166
Chapter 12 – SocketWireless® Bluetooth® (MTS2BTSMI).....	167
Introduction.....	167

Notes about Byte Gaps and Data Latency	167
Product Build Options and Ordering Information	167
AT Commands Reference Guide	167
Technical Specifications	168
Mechanical Drawing – Basic Build and 3.3V Build	169
DC Electrical Characteristics	170
Power Measurements	170
Application Notes	171
Default Power Up Settings.....	171
Example of a Master Discovery/Connection Sequence.....	172
Example of a Slave Command Sequence.....	172
Disabling Flow Control Using AT Commands.....	173
Other Examples.....	173
Changing Configuration.....	173
<i>Index</i>	<i>174</i>

Part 1

Universal Socket Connectivity

Chapter 1 – Universal Socket Connectivity

Chapter 1 – Universal Socket Connectivity

Multi-Tech Embedded Solutions

Multi-Tech’s embedded device networking solutions instantly add communication ability to your existing or new product with minimal engineering effort giving you an edge on your competition while accelerating your time-to-market. Our universal socket family of embedded solutions is designed around a flexible comm-port architecture to provide analog dial-up, cellular, Wi-Fi or Bluetooth® cellular, or Ethernet socket connectivity with interchangeable socket devices. This means you can utilize one system design and populate it with your preferred connectivity option giving you flexibility and a seamless migration path to future technologies.

Universal Socket Connectivity Features

- Flexible comm-port architecture
- Interchangeable socket devices
- Cost-effective system design
- Easy migration to future technologies
- Complete global compliance

The Universal Socket Design

Each pin on a SocketModem corresponds to a particular function. The universal socket design provides a universal location for each function pin. This allows each SocketModem to be used in a common board.

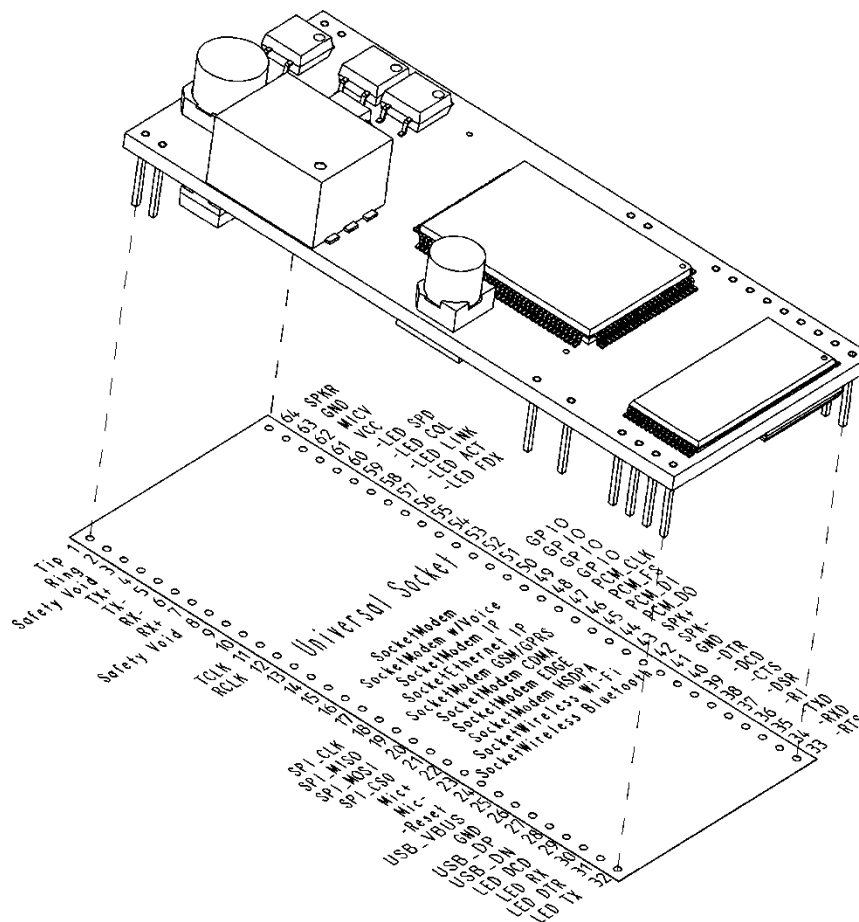

Universal Developer Kit Contents

Products described in this guide can be used to develop and evaluate your products and applications using the MTSMI-UDK (Universal Developer Kit).

- **Developer Board:** One MTSMI-UDK Developer Board
- **Power Supply:** One 100-240V 9V-1.7A power supply with removable blades:
 - ◆ One US blade/plug
 - ◆ One EURO blade/plug
 - ◆ One UK blade/plug
- **Cables**
 - ◆ One RS-232 DB9F-DB25M serial cable
 - ◆ One RJ-11 phone cable
 - ◆ One RJ-45 Ethernet cable
 - ◆ One 1.5 meter USB cable
- **Antenna Cables**
 - ◆ One SMA-to-MMCX antenna cable (for cellular antennas)
 - ◆ Two SMA-to-UFL antenna cables (one for select cellular antennas and one for GPS antennas)
 - ◆ One RSMA-to-MMCX antenna cable (for Bluetooth antennas)
 - ◆ One RSMA-to-UFL antenna cable (for Wi-Fi antennas)
- **Antennas**
 - ◆ One quad band antenna 850/1900/900/1800 (for cellular modems)
 - ◆ One 2.4GHz, ½ WAVE antenna with reverse polarity (for Bluetooth and Wi-Fi devices)
 - ◆ One GPS antenna
- **Modem Activation Customer Notices**
 - ◆ [Aeris Communications, Inc.](#)
 - ◆ GSM
 - ◆ [Sprint Nextel](#)
 - ◆ [Verizon Wireless](#)
- **One Universal Socket Connectivity Developer CD**
- **One Promotional Screwdriver**

AT Commands for All Embedded Products Are Included on the Developer Kit CD

AT Commands

Multi-Tech provides Reference Guides for each SocketModem's AT commands. These reference guides are available on the CD included in the Developer Kit. They are also available by email at [mailto: oemsales@multitech.com](mailto:oemsales@multitech.com) or by using the *Developer Guide Request Form* on Multi-Tech's Web site.

Fax Commands for Analog Modems

Fax Commands are included in the AT Command Reference Guide when applicable to the product. They are available on the CD included in the Developer Kit.

Note: Fax Commands supported by product:

- SocketModem MT9234SMI supports all Class 1 and Class 2 commands (Class 1, 1.0, 2, 2.0/2.1)
- SocketModem MT5692SMI supports Class 1 & 1.0

Universal Socket Pin Out

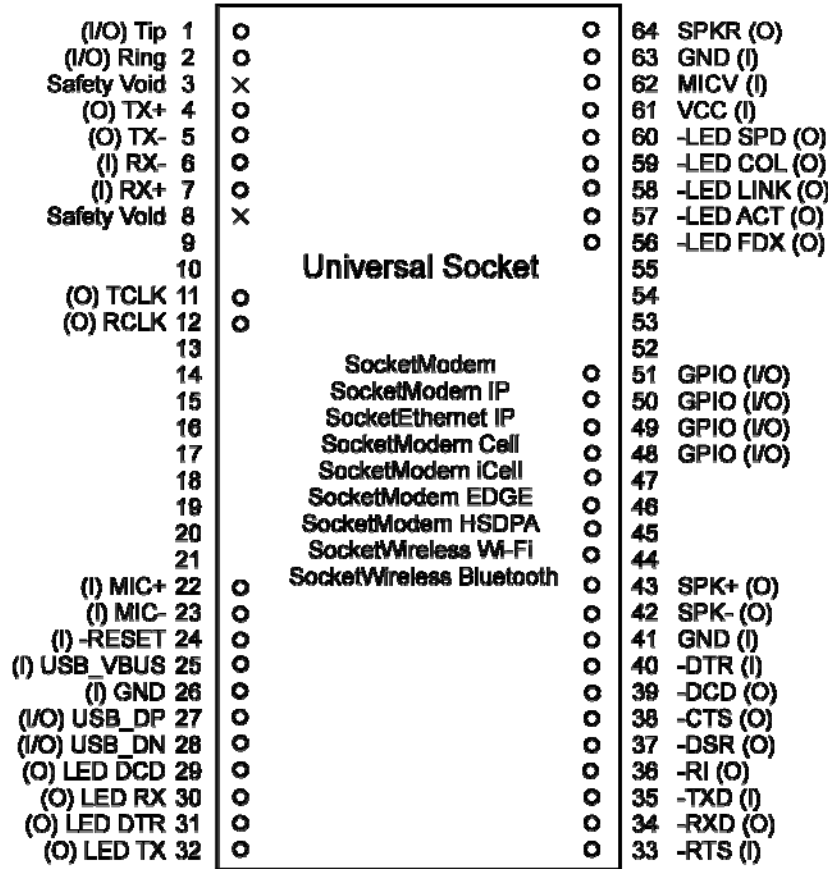

Top View – Universal SocketModem Pin Out

Important Note:

Not all products include all pins as shown above and listed below. See the *Mechanical Drawings* section in each product chapter for the pins used by that product.

Universal Pin Descriptions

Pin	Signal Name	In/Out	Description
1	Tip	I/O	Tip Signal from Telco. Tip connection to the phone line (RJ-11 Pin 4). The SocketModem is Tip/Ring polarity insensitive.
2	Ring	I/O	Ring Signal from Telco. Ring connection to the phone line (RJ-11 Pin 3). The SocketModem is Tip/Ring polarity insensitive.
3	Safety Void	NA	Safety Clearance. 2.5 mm is required between TNV circuits and SELV circuits.
4	TX+	O	Transmit Outputs (TX+ and TX-). Differential transmit outputs for Ethernet and ISDN.
5	TX-	O	Transmit Outputs (TX+ and TX-). Differential transmit outputs for Ethernet and ISDN.
6	RX-	I	Receive Inputs. Differential receive input pins for Ethernet. Dummy pin for MT810SWM-IP.
7	RX+	I	Receive Inputs. Differential receive input pins for Ethernet.
8	Safety Void	NA	Safety Clearance. 2.5 mm is required between TNV circuits and SELV circuits.
9	Dummy		Dummy pin for EDGE.
11	TCLK	O	Transmit Data Sync Clock. TX synchronous data clock for ISDN sync data mode.
12	RCLK	O	Receive Data Sync Clock. RX synchronous data clock for ISDN sync data mode.
22	MIC+	I	Microphone positive input. See microphone sections in GPRS, CDMA, EDGE chapters.
23	MIC-	I	Microphone negative input. See microphone sections in GPRS, CDMA, EDGE chapters.

Pin	Signal Name	In/Out	Description																																																
24	–RESET*	I	<p>Device Reset (with pull-up). The active low –RESET input resets the device logic and returns the configuration of the device to the original factory default values or "stored values" in the NVRAM. –RESET is tied to VCC through a time-constant circuit for "Power-on-Reset" functionality. The SocketModem is ready to accept commands after a fixed amount of time ("X" Time) after power-on or reset.</p> <table border="1"> <thead> <tr> <th>Model</th> <th>Time Constant</th> <th>"X" Time</th> <th>Minimum Reset Pulse*</th> </tr> </thead> <tbody> <tr> <td>MTSMC-G2</td> <td>250 ms</td> <td>6 seconds</td> <td>100us</td> </tr> <tr> <td>MTSMC-C1</td> <td>250 ms</td> <td>3-15 seconds</td> <td>500us</td> </tr> <tr> <td>MTSMC-E1</td> <td>250 ms</td> <td>3-15 seconds</td> <td>500us</td> </tr> <tr> <td>MTSMC-H4</td> <td>250 ms</td> <td>10 seconds</td> <td>200us</td> </tr> <tr> <td>MTSMC-EV2</td> <td>250 ms</td> <td>10 seconds</td> <td>200us</td> </tr> <tr> <td>MT9234SMI</td> <td>400 ms</td> <td>6 seconds</td> <td>100us</td> </tr> <tr> <td>MT5692SMI</td> <td>250 ms</td> <td>6 seconds</td> <td>100us</td> </tr> <tr> <td>MT2492SMI</td> <td>250 ms</td> <td>6 seconds</td> <td>100us</td> </tr> <tr> <td>MT100SEM-IP</td> <td>250 ms</td> <td>6 seconds</td> <td>100us</td> </tr> <tr> <td>MT810SWM-IP</td> <td>250 ms</td> <td>6 seconds</td> <td>100us</td> </tr> <tr> <td>MTS2BTSMI</td> <td>250 ms</td> <td>6 seconds</td> <td>100us</td> </tr> </tbody> </table> <p>*The SocketModem device may respond to a shorter reset pulse.</p> <p>Reset Line Interface for the MT5692SMI. The modem's reset line employs a 10K pull up resistor. If an open collector driver is to be used, run that output to the modem only and use a separate driver for other embedded components. The modem's reset signal may also be driven by a circuit that both sinks and sources current if desired. It is also important to note that these modems do not require an external reset. They have their own internal reset circuitry and voltage monitor and will function correctly even if the reset input is open.</p> <p>Reset GPRS and CDMA (MTSMC-G2 and MTSMC-C1). This signal is used to force a reset procedure by providing low level during reset of at least 500us. The signal is considered an emergency reset only. A reset procedure is already driven by internal hardware during the power-up sequence. If no external reset is necessary, this input can be left open. If used (emergency reset), it has to be driven by an open collector or an open drain.</p> <p>Reset EDGE with pull-up (MTSMC-E1). The active low –RESET input resets the device logic and returns the configuration of the device to the original factory default values of "stored values" in the NVRAM. The SocketModem is ready to accept commands after a fixed amount of time after power-on or reset.</p>	Model	Time Constant	"X" Time	Minimum Reset Pulse*	MTSMC-G2	250 ms	6 seconds	100us	MTSMC-C1	250 ms	3-15 seconds	500us	MTSMC-E1	250 ms	3-15 seconds	500us	MTSMC-H4	250 ms	10 seconds	200us	MTSMC-EV2	250 ms	10 seconds	200us	MT9234SMI	400 ms	6 seconds	100us	MT5692SMI	250 ms	6 seconds	100us	MT2492SMI	250 ms	6 seconds	100us	MT100SEM-IP	250 ms	6 seconds	100us	MT810SWM-IP	250 ms	6 seconds	100us	MTS2BTSMI	250 ms	6 seconds	100us
Model	Time Constant	"X" Time	Minimum Reset Pulse*																																																
MTSMC-G2	250 ms	6 seconds	100us																																																
MTSMC-C1	250 ms	3-15 seconds	500us																																																
MTSMC-E1	250 ms	3-15 seconds	500us																																																
MTSMC-H4	250 ms	10 seconds	200us																																																
MTSMC-EV2	250 ms	10 seconds	200us																																																
MT9234SMI	400 ms	6 seconds	100us																																																
MT5692SMI	250 ms	6 seconds	100us																																																
MT2492SMI	250 ms	6 seconds	100us																																																
MT100SEM-IP	250 ms	6 seconds	100us																																																
MT810SWM-IP	250 ms	6 seconds	100us																																																
MTS2BTSMI	250 ms	6 seconds	100us																																																
25	USB_VBUS	I	USB Voltage Sense. Senses the voltage level of the USB to determine if the bus is available.																																																
26	GND	GND	Logic Ground.																																																
27	USB_DP	I/O	USB Data Positive. Positive pin of the USB data pair.																																																
28	USB_DN	I/O	USB Data Negative. Negative pin of the USB data pair.																																																
29	LED DCD	O	DCD (Active High). Output from 74LCX14 with a 1000 Ohms resistor in series. SocketWireless Bluetooth (MTS2BTSMI): When lit, indicates a connection. No series resistor.																																																
30	LED RX	O	RX (Active High). Output from 74LCX14 with a 1000 Ohms resistor in series. SocketWireless Bluetooth (MTS2BTSMI): No series resistor.																																																
31	LED DTR	O	DTR (Active High). Output from 74LCX14 with a 1000 Ohms resistor in series. SocketWireless Bluetooth (MTS2BTSMI): No series resistor.																																																
32	LED TX	O	TX (Active High). Output from 74LCX14 with a 1000 Ohms resistor in series. SocketWireless Bluetooth (MTS2BTSMI): No series resistor.																																																
33	–RTS	I	Request to Send (Active Low). –RTS is controlled by the DTE to indicated whether or not the DTE is ready to receive data. –RTS ON (low) indicates that the DTE is ready to receive data from the modem on RXD. –RTS OFF indicates to the SocketModem that it should not transfer data on the RXD. Note: When the –RTS pin is not in use, it should be tied low.																																																

* **RESET – A Design Consideration:** Allowing the host processor to control the RESET line of the SocketModem provides the benefit of allowing the host to reset the device in the event of a failure to respond normally. Resetting the SocketModem will return it to a known functional state.

Pin	Signal Name	In/Out	Description
34	-RXD	O	Received Data. The SocketModem uses the RXD line to send data to the DTE and to send SocketModem responses to the DTE. In command mode, -RXD data presents the SocketModem responses to the DTE. SocketModem responses take priority over incoming data when the two signals are in competition for -RXD. When no data is transmitted, the signal is held in mark condition.
35	-TXD	I	Transmitted Data. The DTE uses the -TXD line to send data to the SocketModem for transmission or to transmit commands to the SocketModem. The DTE holds this circuit in mark state when no data is being transmitted or during intervals between characters.
36	-RI	O	RING (Active Low). Incoming ring signal from phone. Ring Indicate. -RI output ON (low) indicates the presence of an ON segment of a ring signal on the telephone line. The modem will not go off-hook when -RI is active; the modem waits for -RI to go inactive before going off-hook. SocketWireless Bluetooth (MTS2BTSMI). Strobes 1/sec for slave indication.
37	-DSR	O	Data Set Ready (Active Low). -DSR indicates SocketModem status to the DTE. -DSR OFF (high) indicates that the DTE is to disregard all signals appearing on the interchange circuits except Ring Indicator (-RI). It reflects the status of the local data set and does not indicate an actual link with any remote data equipment.
38	-CTS	O	Clear to Send (Active Low). -CTS is controlled by the SocketModem to indicate whether or not the SocketModem is ready to transmit data. -CTS ON indicates to the DTE that signals on TXD will be transmitted. -CTS OFF indicates to the DTE that it should not transfer data on TXD.
39	-DCD	O	Data Carrier Detect (Active Low). -DCD output is ON (low) when a data connection is established and the SocketModem is ready to send/receive data.
40	-DTR	I	Data Terminal Ready (Active Low). The -DTR input is turned ON (low) when the DTE is ready to communicate. -DTR ON prepares the modem to be connected, and, once connected, maintains the connection. -DTR OFF places the modem in the disconnect state under control of the &Dn and &Qn commands. Note: When the -DTR pin is not in use, it should be tied low.
41	GND	GND	Logic Ground.
42	SPK-	O	Cellular GPRS, CDMA, and EDGE. Negative analog speaker output.
43	SPK+	O	Cellular GPRS, CDMA, and EDGE. Positive analog speaker output.
48	GPIO*	I/O	General Purpose Input/Output. User-configurable input or output pin. **
49	GPIO*	I/O	General Purpose Input/Output. User-configurable input or output pin. **
50	GPIO*	I/O	General Purpose Input/Output. User-configurable input or output pin. **
51	GPIO*	I/O	General Purpose Input/Output. User-configurable input or output pin. **
56	-LED FDX	O	LED Full Duplex (Active Low). LED Output. During normal operation, this pin lights the FDX LED to indicate a full duplex mode.
57	-LED ACT	O	LED Active (Active Low). LED Output. During normal operation, this pin lights the Activity LED when transmitting or receiving. It flashes at a rate of 50ms high and 50ms low when active.
58	-LEDLINK	O	LED LINK (Active Low). LED Output. During normal operation, this pin lights the LINK LED to indicate a good link is detected.

* GPIO pins can be configured using the Universal IP AT Commands. Refer to the Universal IP AT Commands Reference Guide on the CD included with the Universal Developer Kit.

** For MTSMC-H4-MI-IP, MTSMC-H4-MI-GP, MTSMC-EV2-MI-IP, MTSMC-EV2-MI-GP only.

Pin 58 LED Mode	Operating Status
Note: Pin 58 may or may not be available on some EDGE/GPRS/CDMA SocketModems currently shipping.	
Off	Subscriber Carrier Mode is OFF or running in SLEEP mode or Alarm mode.
600 ms ON / 600ms OFF	No SIM card inserted or no PIN entered, or network search in progress, or ongoing user authentication, or network login in progress.
75 ms ON / 75 ms OFF / 75 ms ON 3 s OFF Flashing or Blinking	One or more EDGE/GPRS/CDMA contexts activated. Indicates EDGE/GPRS/CDMA data transfer: When a transfer is in progress, the LED goes on within 1 second after data packets were exchanged. Flash duration is approximately 0.5 s.
ON	Depending on type of call: Voice Call: Connected to remote party. Data Call: Connected to remote party or exchange of parameters while setting up or disconnecting a call.

Pin	Signal Name	In/Out	Description
59	-LEDCOL	O	LED Collision (Active Low) . LED Output. During normal operation, this pin lights the COL LED to indicate a collision. It flashes at 50ms high and 50ms low when active.
60	-LEDSPD	O	LED Speed (Active Low) . LED Output. During normal operation, this pin lights the SPEED LED to indicate 100Mbps is selected.
61	VCC	PWR	DC Input Power . 3.3V or 5VDC power, depending upon the build.
62	MICV	I	Single-Ended Microphone . Single-ended microphone input for dial-up SocketModem speakerphone and TAM functions.
63	AGND	GND	Analog Ground . Analog ground is tied common with DGND on the SocketModem. To minimize potential ground noise issues, connect audio circuit return to AGND.
64	SPKR	O	Speaker . Dual purpose output for call progress signals or speakerphone functions. Call Progress signaling on MT5692SMI and MT2492SMI is a square wave output that can be optionally connected to a low-cost single-ended speaker; e.g., a sounducer or an analog speaker circuit. Call progress on the MT9234SMI is an analog output. Speakerphone Output on the MT5692SMI is under the control of +FCLASS. This is a single-ended analog output. SPKR is tied directly to the CODEC. One side of a differential AC output coupled through a 6.8K ohm resistor and capacitor.

Design Considerations

Noise Suppression Design Considerations

Engineering noise-suppression practices must be adhered to when designing a printed circuit board (PCB) containing the SocketModem. Suppression of noise is essential to the proper operation and performance of the modem itself and for surrounding equipment.

Two aspects of noise in an OEM board design containing the SocketModem must be considered: on-board/off-board generated noise that can affect digital signal processing. Both on-board and off-board generated noise that is coupled on-board can affect interface signal levels and quality. Of particular concern is noise in frequency ranges affecting modem performance.

On-board generated electromagnetic interference (EMI) noise that can be radiated or conducted off-board is a separate, but equally important, concern. This type of noise can affect the operation of surrounding equipment. Most local government agencies have stringent certification requirements that must be met for use in specific environments.

Proper PC board layout (component placement, signal routing, trace thickness and geometry, etc.) component selection (composition, value, and tolerance), interface connections, and shielding are required for the board design to achieve desired modem performance and to attain EMI certification.

Other aspects of proper noise-suppression engineering practices are beyond the scope of this designer guide. The designer should consult noise suppression techniques described in technical publications and journals, electronics and electrical engineering text books, and component supplier application notes.

PC Board Layout Guidelines

In a 4-layer design, provide adequate ground plane covering the entire board. In 4-layer designs, power and ground are typically on the inner layers. All power and ground traces should be 0.05 inches wide.

The recommended hole size for the SocketModem pins is 0.036 in. +/-0.003 in. in diameter. Spacers can be used to hold the SocketModem vertically in place during the wave solder process.

All creepages and clearances for the SocketModem have been designed to meet requirements of safety standards EN60950 or EN60601. The requirements are based on a working voltage of 125V or 250V. When the recommended DAA* circuit interface is implemented in a third party design, all creepage and clearance requirements must be strictly followed in order to meet safety standards. The third party safety design must be evaluated by the appropriate national agency per the required specification.

User accessible areas: Based on where the third party design is to be marketed, sold, or used, it may be necessary to provide an insulating cover over all TNV exposed areas. Consult with the recognized safety agency to determine the requirements.

Note: Even if the recommended design considerations are followed, there are no guarantees that a particular system will comply with all the necessary regulatory requirements. It is imperative that specific designs be completely evaluated by a qualified/recognized agency.

**DAA stands for Data Access Arrangement. DAA is the telephone line interface of the SocketModem.*

Important

MTSMC Tooling Holes and Mounting Hardware

It is recommended that nylon hardware be used if the SocketModems are to be mounted using the two tooling holes due to possible traces and vias around the tooling holes. #4 or M2/M3 hardware should be used for mounting. This applies to the following cellular SocketModems:

SocketModem® Cell & SocketModem® iCell GPRS (MTSMC-G2)

SocketModem® Cell and SocketModem® iCell CDMA 1xRTT (MTSMC-C1)

SocketModem® Cell & SocketModem® iCell HSPA (MTSMC-H4)

SocketModem® Cell & SocketModem® iCell EV-DO (MTSMC-EV2)

Note: See the Mechanical Drawings for these SocketModems.

Electromagnetic Interference (EMI) Considerations

The following guidelines are offered specifically to help minimize EMI generation. Some of these guidelines are the same as, or similar to, the general guidelines but are mentioned again to reinforce their importance. In order to minimize the contribution of the SocketModem-based design to EMI, the designer must understand the major sources of EMI and how to reduce them to acceptable levels.

1. Keep traces carrying high frequency signals as short as possible.
2. Provide a good ground plane or grid. In some cases, a multilayer board may be required with full layers for ground and power distribution.
3. Decouple power from ground with decoupling capacitors as close to the SocketModem power pins as possible.
4. Eliminate ground loops, which are unexpected current return paths to the power source and ground.
5. Decouple the telephone line cables at the telephone line jacks. Typically, use a combination of series inductors, common mode chokes, and shunt capacitors. Methods to decouple telephone lines are similar to decoupling power lines; however, telephone line decoupling may be more difficult and deserves additional attention. A commonly used design aid is to place footprints for these components and populate as necessary during performance/EMI testing and certification.
6. Decouple the power cord at the power cord interface with decoupling capacitors. Methods to decouple power lines are similar to decoupling telephone lines.
7. Locate high frequency circuits in a separate area to minimize capacitive coupling to other circuits.
8. Locate cables and connectors so as to avoid coupling from high frequency circuits.
9. Lay out the highest frequency signal traces next to the ground grid.
10. If a multilayer board design is used, make no cuts in the ground or power planes and be sure the ground plane covers all traces.
11. Minimize the number of through-hole connections on traces carrying high frequency signals.
12. Avoid right angle turns on high frequency traces. Forty-five degree corners are good; however, radius turns are better.
13. On 2-layer boards with no ground grid, provide a shadow ground trace on the opposite side of the board to traces carrying high frequency signals. This will be effective as a high frequency ground return if it is three times the width of the signal traces.
14. Distribute high frequency signals continuously on a single trace rather than several traces radiating from one point.

Electrostatic Discharge Control

All electronic devices should be handled with certain precautions to avoid damage due to the accumulation of static charge.

See the ANSI/ESD Association Standard (ANSI/ESD S20.20-1999) – a document “for the Development of an Electrostatic Discharge Control for Protection of Electrical and Electronic Parts, Assemblies and Equipment.” This document covers ESD Control Program Administrative Requirements, ESD Training, ESD Control Program Plan Technical Requirements (grounding/bonding systems, personnel grooming, protected areas, packaging, marking, equipment, and handling), and Sensitivity Testing.

Multi-Tech Systems, Inc. strives to follow all of these recommendations. Input protection circuitry has been incorporated into the Multi-Tech devices to minimize the effect of this static buildup, proper precautions should be taken to avoid exposure to electrostatic discharge during handling.

Multi-Tech uses and recommends that others use anti-static boxes that create a faraday cage (packaging designed to exclude electromagnetic fields). Multi-Tech recommends that you use our packaging when returning a product and when you ship your products to your customers.

Phone Line Warning Statement for the Developer Board

Use extreme caution when the phone line is installed due to live energized components. In fact, do not touch any components on the board while the phone line is installed.

In addition, the phone line should be detached when making modifications to or servicing the developer board.

SocketModem Developer Board

This developer board drawing shows the major board components for all SocketModems.

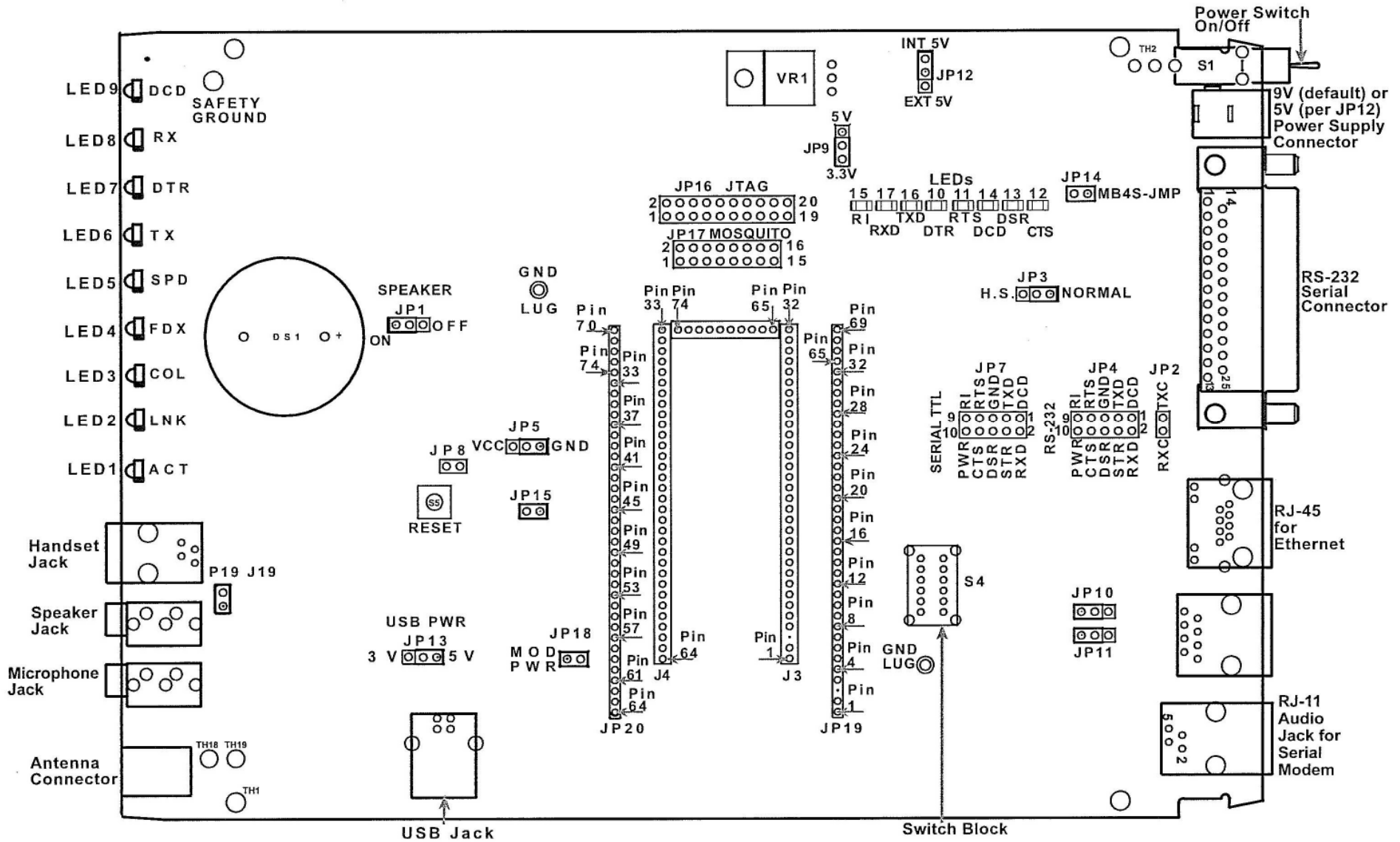

Board Revision B

See the next page for description of Board Components

Board Components

Jumper	Description
JP1	Mutes the speaker. Default positions are 1 and 2 (speaker is not muted).
JP2	Ties the TX and RX clock lines together. Default positions are 1 and 2 (transmit and receive clock act independently).
JP3	Sets the data rate. NORMAL sets the data rate at 250kbps. H.S. (high speed serial communications) sets the data rate at 1Mbps.
JP4	Testing interface (debugging) for the RS-232 signals.
JP5	JP5 acts as a replacement for pin 45 when pin 45 is used for another function.
JP7	Testing interface (debugging) for the serial TTL signals.
JP9	JP9 is the 5V / 3.3V regulator. The factory default operating voltage is 3.3V. Warning – Be sure that the 5V / 3.3V jumper is set to match the requirements of your SocketModem. If this jumper is set incorrectly, damage to the SocketModem and/or the Test/Demo card could result. Caution – Use only the provided Multi-Tech Systems, Inc. transformer with the Test/Demo board. Use of any other power source will void the warranty and will likely damage the Test/Demo board and the SocketModem.
JP12	JP12 allows you to select either the internal 5V regulator (INT 5V) or to choose EXT 5V. For the EXT 5V, you can use your own external 5V power source and plug it into J7.
JP13	Set either 5V or 3.3V for USB_VBUS line (supplied by the VCC of the USB jack).
JP14	Internal testing.
JP15	JP15 disconnects pin 45 from SLP with JP5 (the RS-232 driver sleep mode).
JP16	JTAG header.
JP17	Mosquito header. If used to debug the SocketModem while using the USB port, then the JP14 would have to be removed to disconnect USB_VBUS.
JP18	Power feed for area where SocketModems are placed (J24).
JP19 & JP20	Debugging probes.
JP25 & JP26	Ground lug.
S4	Set the switch block to the product being used.
S5	Reset

Jumpers and Corresponding Signals

J4 and J7			
10	PWR	9	RI
8	CTS	7	RTS
6	DSR	5	GND
4	DTR	3	TXD
2	RXD	1	DCD

J2 and J13			
2	RXC	1	TXC

JP10	JP11
TX Term	RX Term

SocketModem Developer Board Block Diagram

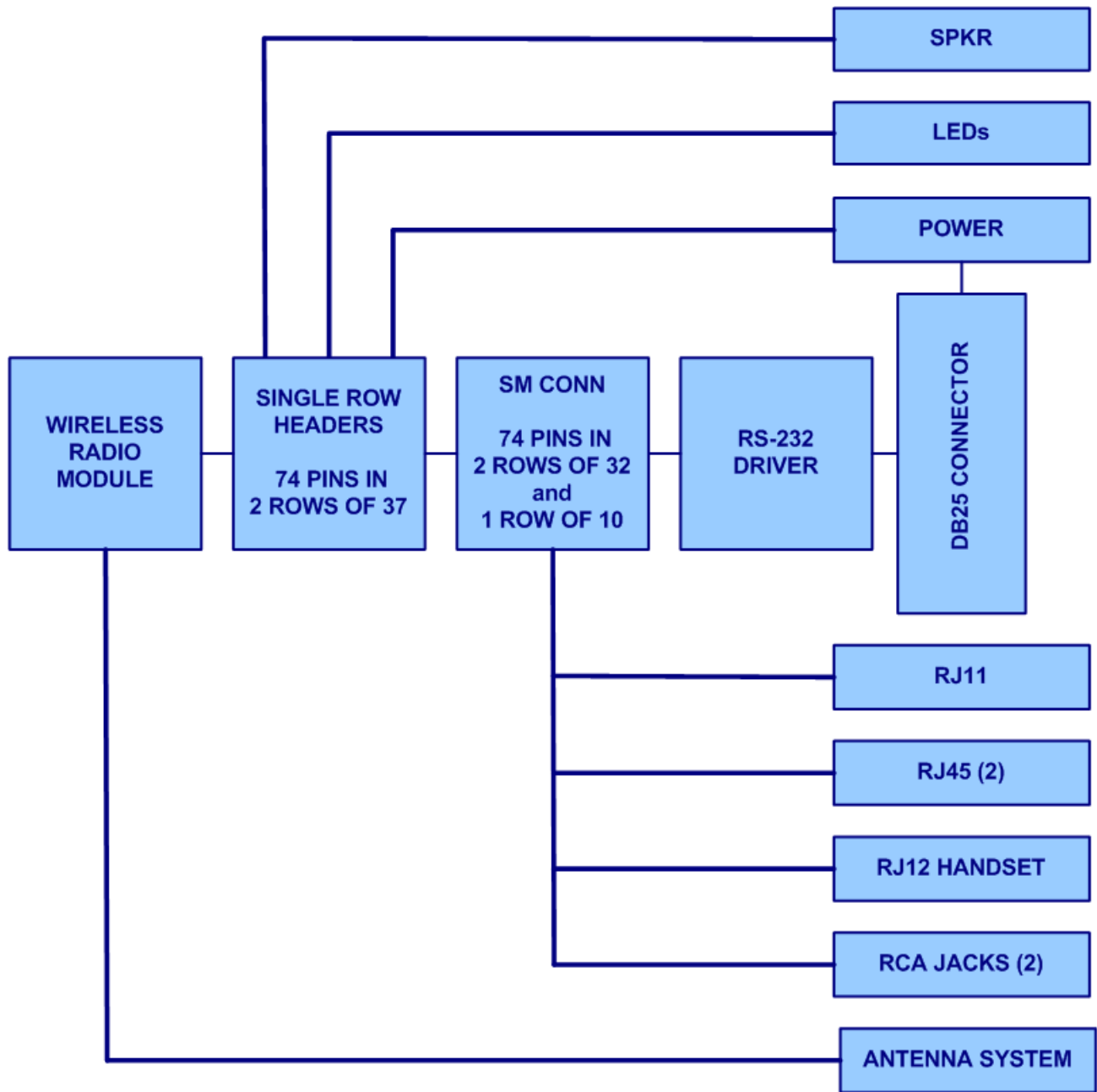

Developer Board Schematics

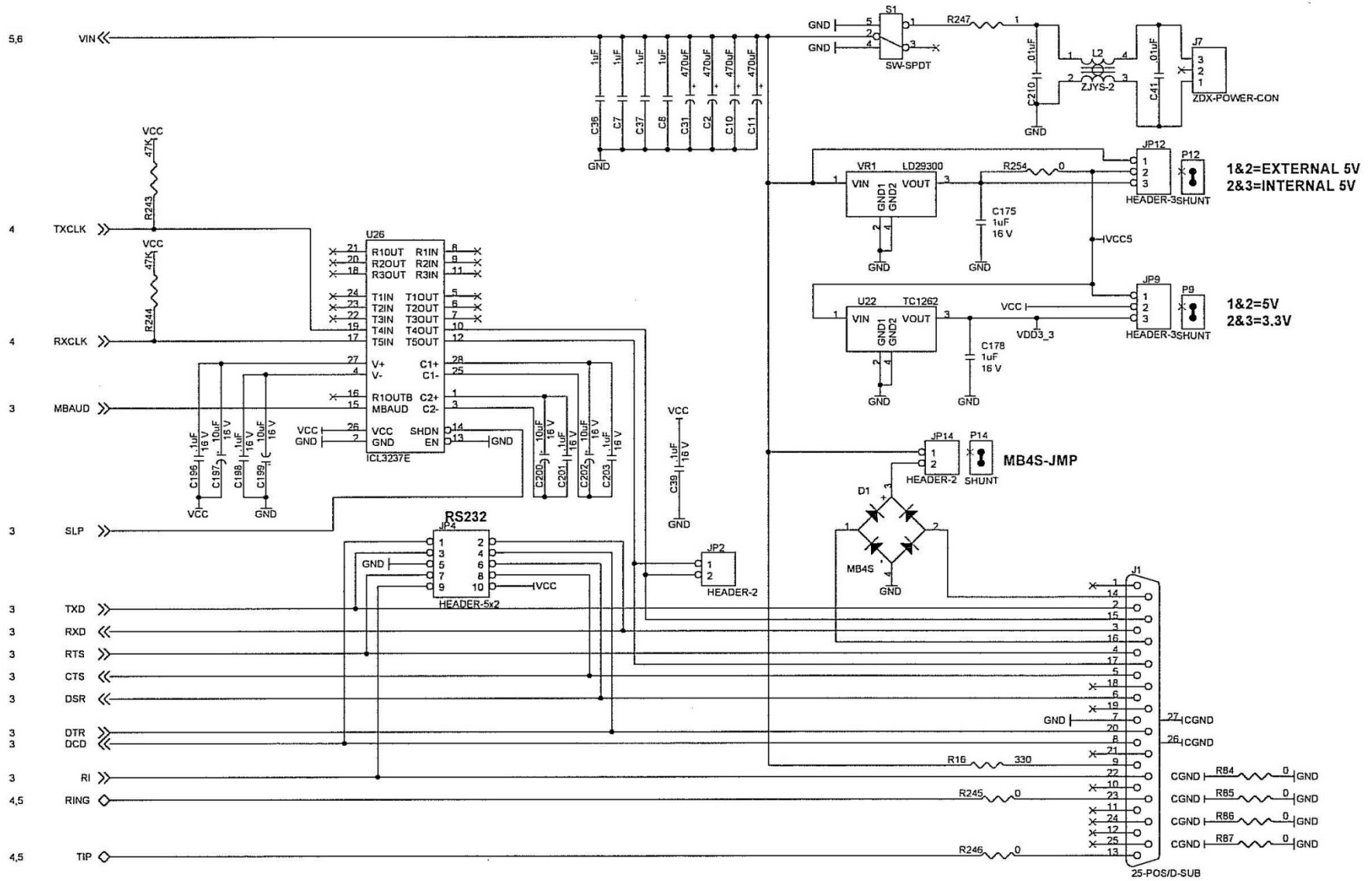

Board Revision B

Developer Board Schematics

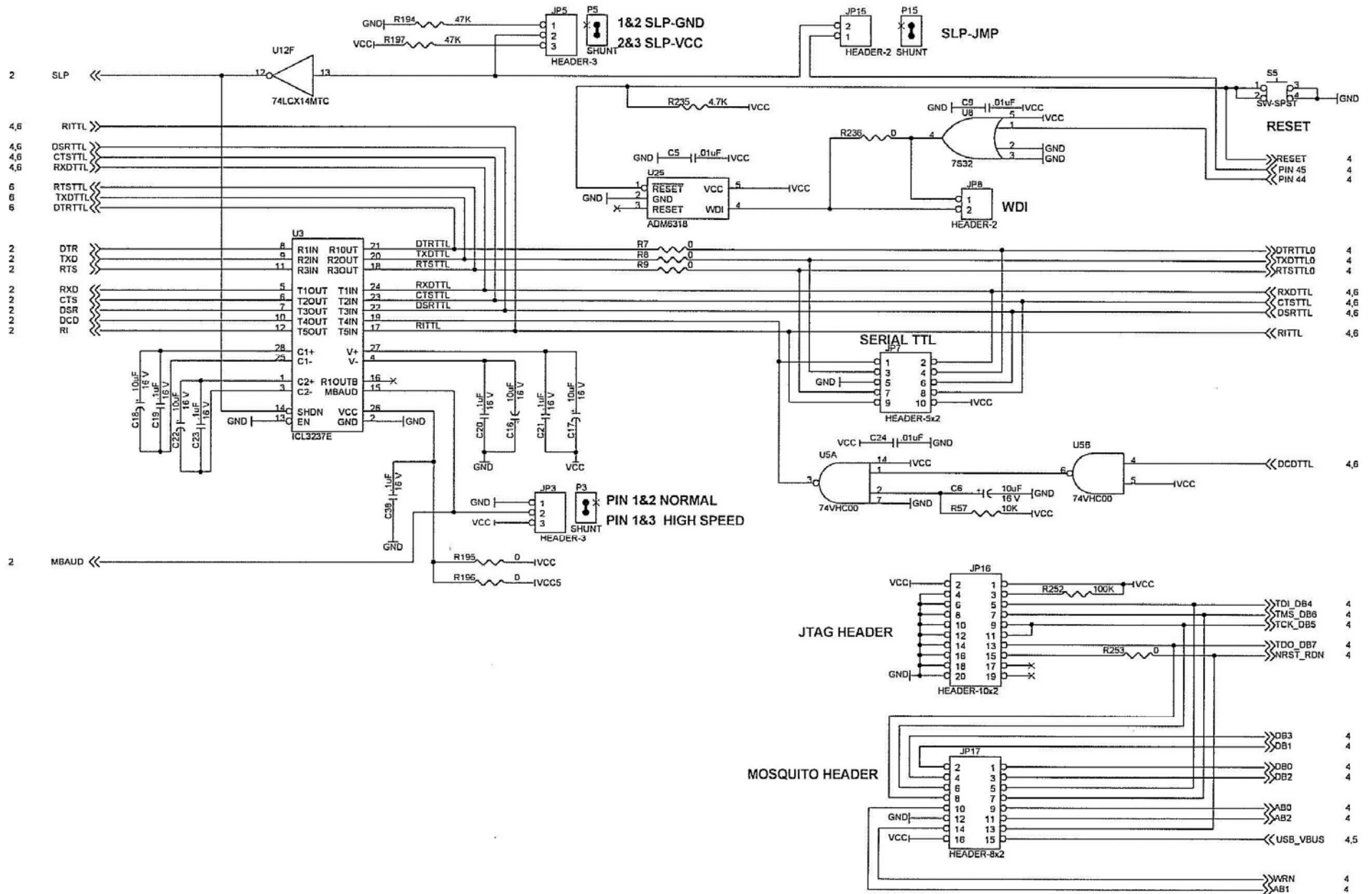

Board Revision B

Developer Board Schematics

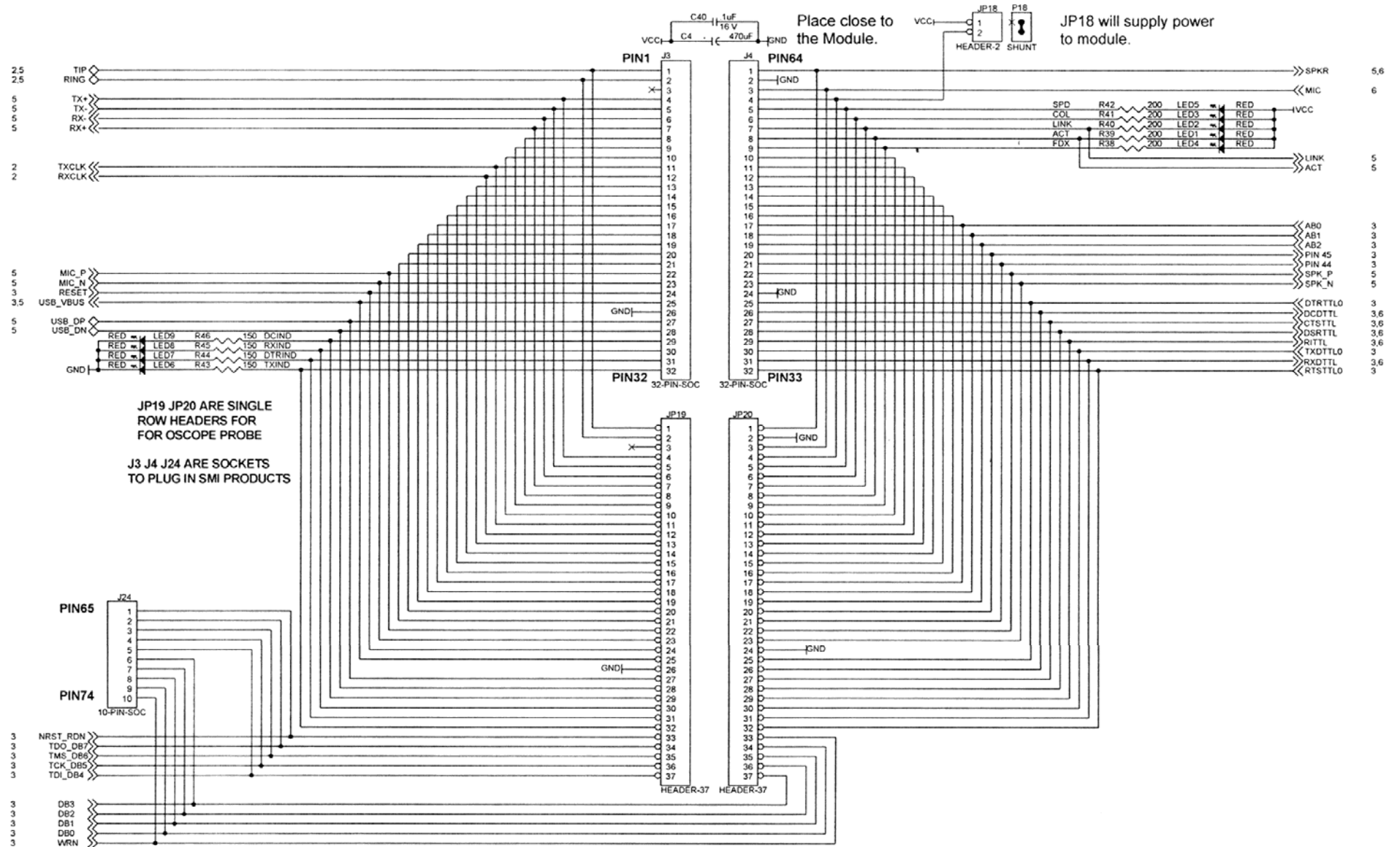

Board Revision B

Developer Board Schematics

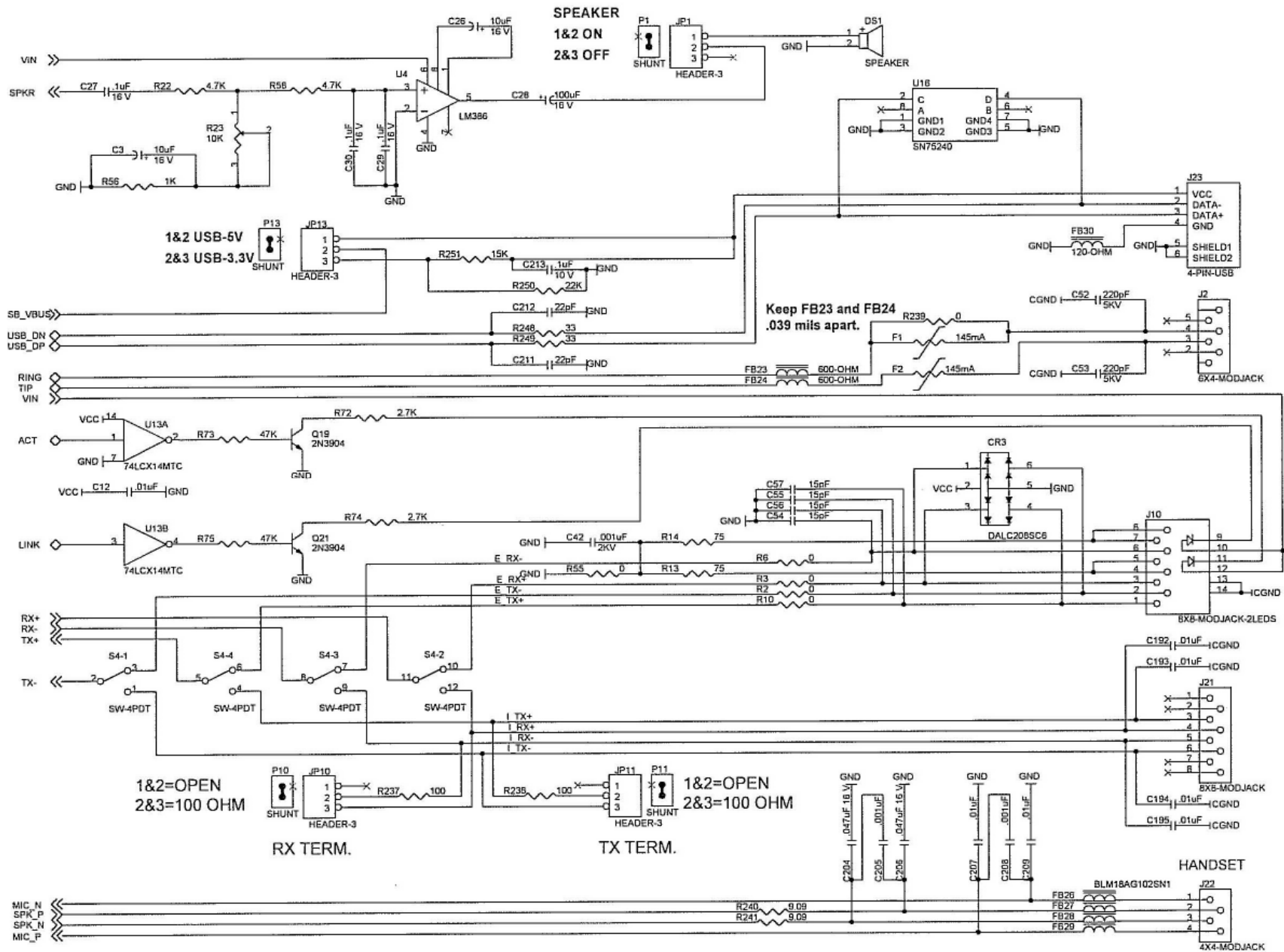

Board Revision B

Developer Board Schematics

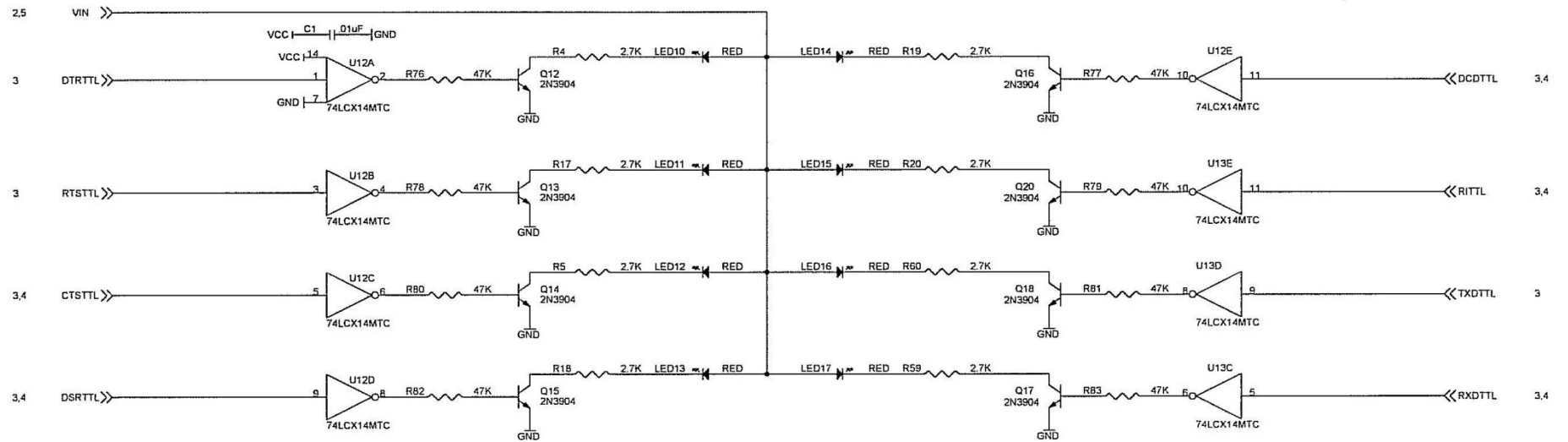
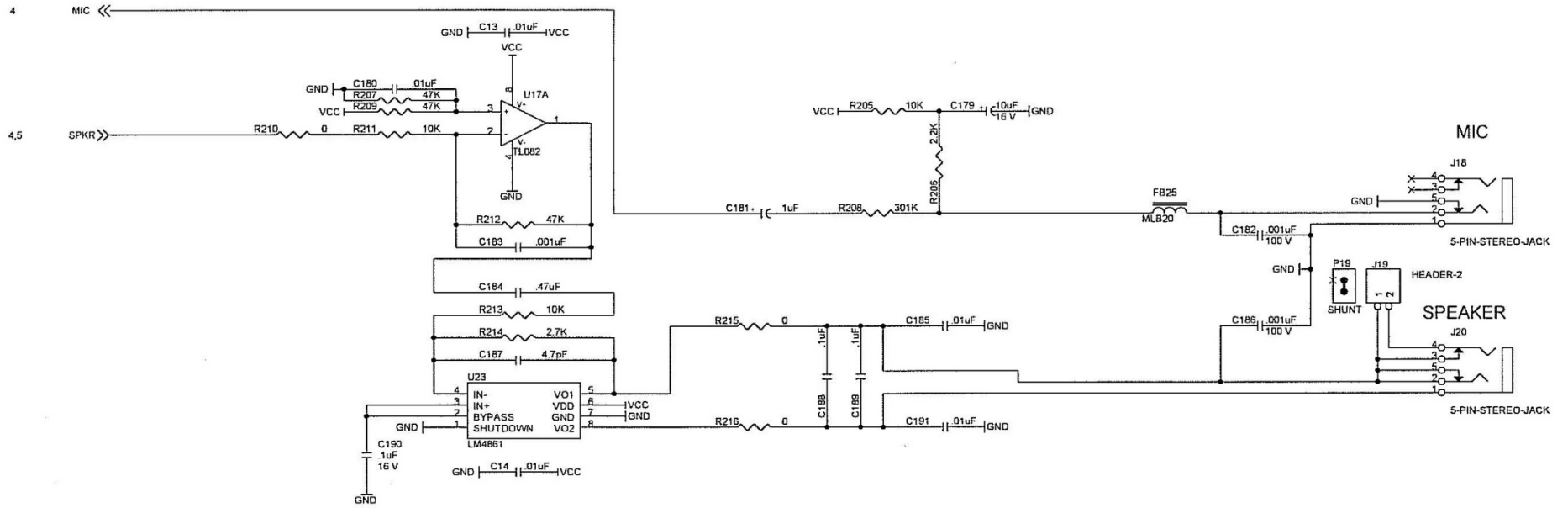

Board Revision B

Upgrading Firmware

Your modem is controlled by semi-permanent firmware, which is stored in flash memory. Multi-Tech's firmware is nonvolatile; that is, it remains stored in memory when the modem is turned off and can be upgraded as new features are added.

Multi-Tech's *Flash Wizard* can be downloaded from Multi-Tech's FTP site and is available on CD. Use this Flash Wizard for upgrading your firmware.

The following table shows you which products support the Flash Wizard. The SocketWireless Wi-Fi (MT810SWM-IP) uses the XMODEM Upgrade feature. Directions for using XMODEM are included on the next page.

Cellular SocketModems	
For all Cellular SocketModems	Do not use the Flash Wizard for the cellular modems. Contact Multi-Tech for cellular modem firmware upgrade directions.
Analog SocketModems	
SocketModem MT9234SMI	Flash Wizard Software for Windows®, Mac OSX, and Linux can use ASCII upload via terminal emulator.
SocketModem MT5692SMI and SocketModem MT5692SMI-IP	Flash Wizard Software for Windows®, Mac OSX, and Linux can use ASCII upload via terminal emulator.
SocketModem MT2492SMI	No Flash Upgrade.
Embedded Device Servers	
SocketEthernet IP MT100SEM-IP	Flash Wizard Software for Windows®, Mac OSX, and Linux can use ASCII upload via terminal emulator.
SocketWireless Wi-Fi MT810SWM-IP	XMODEM serial port upgrade. See the next page for information about using the XMODEM upgrade.
SocketWireless Bluetooth MTS2BTSMI	Do not use the Flash Wizard with the SocketWireless Bluetooth. Contact Multi-Tech for cellular modem firmware upgrade directions.

Flash Wizard Software for Windows®: <ftp://ftp.multitech.com/utilities/flashwizard/3000>

Flash Wizard Software for Linux: <http://mtflashwiz.sourceforge.net/>

XMODEM Serial Port for Firmware Upgrade

Note: This upgrade procedure applies only to the MT810SWM-IP and the older product MTXCSEM.

The IP communications device, for example, contains a 2 MB flash wherein the boot image, the firmware and configuration files are stored in a compressed format. The flash can easily be upgraded both locally as well as remotely.

Serial Port Upgrade

The modem can be upgraded locally through the serial port using the upload feature of serial applications.

Serial Port Configuration

The default serial port parameters should be:

Data length – 8 bits

Parity – None

Stop bits – 1

Baud-rate of the serial port to which the communications device is connected should be set to 115200 bps for proper operation.

Example of a Serial Flash Upgrade

Following steps explain the procedure to upgrade a flash using the serial COM port (serial flash upgrade).

Connect the communications device to a PC COM Port.

- Open an application through which we can access the serial device (e.g., Meterm, zoc, hyperterm).
- Reboot the communications device.
- Wait for the boot message and prompt “press d to download” to appear.
- Press **d** when prompted.
- Select the **XMODEM** Protocol from the Terminal application.
- Choose a file to be uploaded.
- Perform a file upload.

The communications device reboots and will be up after a few seconds (10-15 seconds).

Caution: Refrain from powering off the device during flash upgrade.

Multi-Tech Systems, Inc. Flash Programming Protocol

This information is provided exclusively for the users of Multi-Tech Systems, Inc. SocketModems, specifically the **MT9234SMI**.

Multi-Tech Systems, Inc. SocketModem owners have the right to use, modify, and incorporate this code into other products provided they include the Multi-Tech Systems, Inc. notice and the associated copyright notice with any such product.

Copyright (C) Multi-Tech Systems, Inc. 1995
All Right Reserved

The flash programming protocol is provided "AS IS" without warranty.

Important: When interacting with the boot code, it is possible to make the modem inoperable.
Use extreme caution.

Programming the Modem

There are two ways to start flash programming a modem. It can be programmed

1. From "AT" mode
2. When the modem powers up.

The following table shows how a modem is programmed.

DTE	Modem	Comments
AT*FS\r		This effectively "restarts" the modem so that it enters the boot code.
Handshake Sequence		
M's		Many M's are sent (10 milliseconds apart) at 19200 baud. This is where the handshake starts if the modem is just powered up.
	U	U is sent at 19200 baud if M's are received within 100 milliseconds of power up. If the M's are not received within 100 milliseconds, then the modem starts up normally. If the AT*FS command is used, then you have 1 second (1000mS) to perform the handshake.
D		Sent at 19200 baud.
	M	M if can receive at 9600/19200/38400/57600/115200
	I J K L M	I if modem will be programmed at 9600 J if modem will be programmed at 19200 K if modem will be programmed at 38400 L if modem will be programmed at 57600 M if modem will be programmed at 115200
	\r\nOK\r\n	Modem is ready to be programmed
Program Sequence:		
DTE	Modem	Comments
ATFLP\r		Request to the modem to program
	G	Modem is ready for next program packet
[Length High]		High byte of data packet length
[Length Low]		Low byte of data packet length Packet lengths can be up to 4096 bytes in size for most boot code versions
[Address High]		High byte of program address
[Address Middle]		Middle byte of program address
[Address Low]		Low byte of program address Addresses are 3 byte values with a range of 00000h-FFFFFh
[Data Bytes]		These are the data bytes to be programmed at the address specified above. They must be the same number of bytes as specified above.
[Checksum]		This checksum is generated by exclusive ORing together all of the Data Bytes (do not include the Length or Address bytes in that calculation).
	\r\nOK\r\n \r\nERROR\r\n	If bytes are programmed and verified. If verify fails or checksum is bad. Retry the block 3 times on an ERROR.
....	More of the above sequence until all the data bytes have been sent to the modem.
ATFLEND\r		This ends programming and restarts the modem.

Other Supported Boot Code Commands

2.1	ATI0 -	returns 000 or 247 for ISDN
2.2	ATI1 -	returns boot code version number MM.mmn where MM = unique code for each different platform that has boot code mm = version number of boot code n = version letter of the boot code Examples: 2.05e, 2.12d, 35.15
	ATI4-	Boot code date and time.

Other Programming Concerns

1. The packets sent to the modem must be presorted by address and aligned on 128 byte boundaries (i.e., each packet must start on an address that is a multiple of 128).
2. The packets should also be a minimum of 128 bytes with the non-programmed bytes set to the hex value of FF.
3. The packets sent to the modem must not span a 4K boundary (i.e., start the packet before it and go over the boundary in the middle of the packet).
4. The 10-millisecond delay between M's at the beginning of the handshake is so that the modem can sync up to the start bit. If the M's are sent one right after another, a data bit might be mistaken as a start bit.
5. Multi-Tech firmware files are in Intel Hex Format and must be read in and formatted into 128-4096 byte blocks before being sent to the modem.

Information about the Intel Hex Format

An Intel Format Hex File is a text file consisting of "records", one per line, that start with a ":" character and include only digits 0-9 and letters A-F. There are three different record types: Extended Address Records, Data Records, and End of File Records.

Data records contain the actual data that is to be programmed into a device. The address contained in the data record needs to be combined with an extended address (by adding the extended address shifted four bits left to the data record address) to determine the actual programming address for the data. If no extended address record is before a given data record in the file, then the extended address value is assumed to be zero.

Data Record

Char Pos	Field Type	Value	Description
1	Record Start	“.”	
2-3	Data Byte Count “NN”		Maximum value is FF (which is 255 data bytes). Typical is 20h which causes the hex record to fit in 80 columns.
4-7	Address	“XXXX”	Lower 16 bits of 20 bit address, most significant byte first. This must be added to Extended Address left shifted four bits.
8-9	Record Type	“00”	Data Record
10+N	Data Bytes	“YY..YY”	The data bytes in hex. Each byte is two characters.
NN+1,2	Checksum	“ZZ”	Zero minus the two's complement addition of all data hex values.
NN+3,4	End of Line	“\r\n”	Carriage Return followed by a Line Feed
Example Data Record in Intel Format :2000A0005BB66DDBB66CD8B060C183060D1B366DDBB66DDBB76DFBF7EFDFBF6EDDBB66DD4			

Extended Address Record

Char Pos	Field Type	Value	Description
1	Record Start	“.”	
2-3	Data Byte Count	“02”	Always 2 bytes for this record type
4-7	Address	“0000”	Not used for this record type (must be zero)
8-9	Record Type	“02”	Extended Address Record
10-13	Extended Address	“EEEE”	Top 16 bits of 20 bit address, most significant byte first
14-15	Checksum	“ZZ”	Zero minus the two’s complement addition of all data hex values
16-17	End of Line	“\r\n”	Carriage Return followed by a Line Feed
Example Extended Address Record in Intel Format :020000021000EC			

End of File Record

Char Pos	Field Type	Value	Description
1	Record Start	“.”	
2-3	Data Byte Count	“00”	Always 2 bytes for this record type
4-7	Address	“0000”	Transfer Address (usually be zero)
8-9	Record Type	“01”	End of File Record
10-11	Checksum	“ZZ”	Zero minus the two’s complement addition of all data hex values
12-13	End of Line	“\r\n”	Carriage Return followed by a Line Feed
Example End of File in Intel Format :00000001FF			

Cellular Information

Antenna System for Cellular Devices

The cellular/wireless performance is completely dependent on the implementation and antenna design. The integration of the antenna system into the product is a critical part of the design process; therefore, it is essential to consider it early so the performance is not compromised. If changes are made to the certified antenna system of the SocketModem, then recertification will be required by specific network carriers such as Sprint. The Antenna System is defined as the UFL connection point from the SocketModem to the specified cable specifications and specified antenna specifications.

FCC Requirements for the Antenna

The antenna gain, including cable loss, for the radio you are incorporating into your product design must not exceed the requirements at 850 MHz and 1900 MHz as specified by the FCC grant for mobile operations and fixed mounted operations as defined in 2.1091 and 1.1307 of the FCC rules for satisfying RF exposure compliance. The antenna used for transmitting must be installed to provide a separation distance of at least 20cm from all persons and must not transmit simultaneously with any other antenna transmitters. User and installers must be provided with antenna installation instructions and transmitter operating conditions to satisfying RF exposure compliance.

Antenna Specifications

CDMA RF Specifications

	CDMA 800	CDMA 1900
Frequency RX	869 to 894 MHz	1930 to 1990 MHz
Frequency TX	824 to 849 MHz	1850 to 1910 MHz

CDMA Antenna Requirements/Specifications

Frequency Range	824 – 894 MHz / 1850 – 1990 MHz
Impedance	50 Ohms
VSWR	VSWR shall not exceed 2.0:1 at any point across the bands of operation
Typical Radiated Gain	2 dBi on azimuth plane
Radiation	Omni-directional
Polarization	Vertical
Antenna Loss	Free space not to exceed -3dB
TRP/TIS	The total radiated power (TRP) at the antenna shall be no less than +21/20 dBm for PCS/CELL channels respectively, and the total isotropic sensitivity (TIS) at the antenna shall be no less than -104/104 dBm for PCS/CELL channels respectively.

PTCRB Requirements for the Antenna

There cannot be any alteration to the authorized antenna system. The antenna system must maintain the same specifications. The antenna must be the same type, with similar in-band and out-of-band radiation patterns.

GSM/EGSM RF Specifications

	GSM 850	EGSM 900	GSM 1800	GSM 1900
Frequency RX	869 to 894 MHz	925 to 960 MHz	1805 to 1880 MHz	1930 to 1990 MHz
Frequency TX	824 to 849 MHz	880 to 915 MHz	1710 to 1785 MHz	1850 to 1910 MHz

GSM Antenna Requirements/Specifications

Frequency Range	824 – 960 MHz / 1710 – 1990 MHz
Impedance	50 Ohms
VSWR	VSWR shall not exceed 2.0:1 at any point across the bands of operation
Typical Radiated Gain	2 dBi on azimuth plane
Radiation	Omni-directional
Polarization	Vertical
Antenna Loss	Free space not to exceed -3db
TRP/TIS	Including cable loss the total radiate power (TRP) at the antenna shall be no less than +22/24.5 dBm for 850/1900 MHz respectively, and the total isotropic sensitivity (TIS) at the antenna shall be no less than -99/101.5 dBm for 850/1900 MHz respectively.

HSPA / UMTS RF Specifications

Bands I, II, V	UMTS 850 Band V	UMTS 1900 Band II	UMTS 2100 Band I
Frequency RX	869 to 894 MHz	1930 to 1990 MHz	2110 to 2170 MHz
Frequency TX	824 to 849 MHz	1850 to 1910 MHz	1920 to 1980 MHz

HSPA / UMTS Antenna Requirements/Specifications

Frequency Range	824 – 960 MHz / 1710 – 1990 MHz / 1920 – 2170 MHz
Impedance	50 Ohms
VSWR	VSWR shall not exceed 2.0:1 at any point across the bands of operation
Typical Radiated Gain	2 dBi on azimuth plane
Radiation	Omni-directional
Polarization	Vertical
Antenna loss	Free space not to exceed -3db
TRP/TIS	Including cable loss the total radiate power (TRP) at the antenna shall be no less than +22/24.5 dBm for 850/1900/ MHz respectively, and the total isotropic sensitivity (TIS) at the antenna shall be no less than -99/101.5 dBm for 850/1900 MHz respectively. Note: 2100MHz is not used by the North America carriers.

GPS (Global Positioning) RF Specifications

	GPS L1
Frequency RX	1575.42
LNA Bias Voltage	5V
LNA Current Consumption	40mA Max

GPS Antenna Requirements/Specifications

Frequency	1575MHz
Impedance	50 Ohms
VSWR	1.5db
Input voltage	3.0V ± 0.3V
GPS TIS	The total isotropic sensitivity (TIS) at the antenna shall be no less than -147 dBm

Wi-Fi RF Specifications

	IEEE 802.11 b/g
Frequency	2.4000 to 2.4835 GHz
Modulation	OFDM & DSSS
Receiver Sensitivity	-88dBm @11Mbps -72dBm @54Mbps
Means Transmit Output Power	14.5dBm for 802.11b 14dBm for 802.11g
Range	Up to 100 meters in free space

Wi-Fi Antenna Requirements/Specifications

Frequency Range	2.4000 to 2.4835 GHz
Impedance	50 Ohms
VSWR	1.5dB
Typical Radiated Gain	5 dBi on azimuth plane
Radiation	Omni-directional
Antenna Loss	Free space not to exceed -3dB
TRP/TIS	The total radiated power (TRP) at the antenna shall be no less than +10 dBm for OFDM/DSSS, 11Mbps, free space and the total isotropic sensitivity (TIS) at the antenna shall be no less than -85dBm for OFDM/DSSS, 11Mbps, free space.

Bluetooth RF Specifications

	IEEE 802.11 b/g
Frequency	2402 to 2480 MHz
Modulation	FHSS & GFSK
Number of Channels	79
Channel Intervals	1MHz
Receiver Sensitivity	-83dBm typical
Transmit Rate	721kbps
Means Transmit Output Power	12dBm maximum
Range	Up to 100 meters in free space

Bluetooth Antenna Requirements/Specifications

Frequency Range	2402 to 2480 MHz
Impedance	50 Ohms
VSWR	1.5dB
Typical Radiated Gain	2 dBi on azimuth plane
Radiation	Omni-directional
Antenna Loss	Free space not to exceed -3dB

Coax Cables Specifications

SMA-to-MMCX and RSMA-to-MMCX Coax Cable

The SMA-to-MMCX cable is included in the Developer Kit for use with SocketModem EDGE (MTSMC-E1). The RSMA-to-MMCX cable is included in the Developer Kit for use with SocketWireless Bluetooth (MTS2BTSMI).

Coax Cable Specifications

Cable Type	Coax Cable
Attenuation	<1.0db
Connector Impedance	50 Ohms
Maximum Cable Length	16" (40 cm)

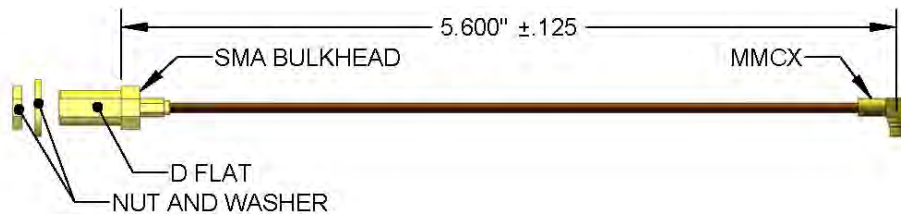

An optional antenna cable (SMA-to-MMCX) can be ordered from Multi-Tech Systems, Inc.

Part Number	Description
CASMA-MMCX-1	SMA-to-MMCX Coax Cable (Single Pack)
CASMA-MMCX-10	SMA-to-MMCX Coax cable (Ten Pack)
CARSMA-MMCX-1	Reverse SMA-to-MMCX Coax Cable (Single Pack)
CARSMA-MMCX-10	Reverse SMA-to-MMCX Coax Cable (Ten Pack)

SMA-to-MMCX Connector

An antenna with an SMA connector may be directly connected to a SocketModem GPRS/CDMA through a mating MMCX-to-SMA connector.

SMA-to-MMCX Connector Available from Amphenol

Amphenol http://www.amphenol.com/ Order No: 908-31100	
--	--

SMA-to-UFL and RSMA-to-UFL Coax Cables

One SMA-to-UFL cable is included in the Developer Kit for use with all cellular modems that have a UFL antenna connector.

A second SMA-to-UFL cable is included in the Developer Kit for use with products that include an optional GPS receiver.

One RSMA-to-UFL cable is included in the Developer Kit for use with the SocketWireless Wi-Fi (MT810SWM-IP).

Coax Cable Specifications

Cable Type	Coaxial Cable
Attenuation	<1.0db
Connector Impedance	50 ohm
Maximum Cable Length	16" (40 cm)

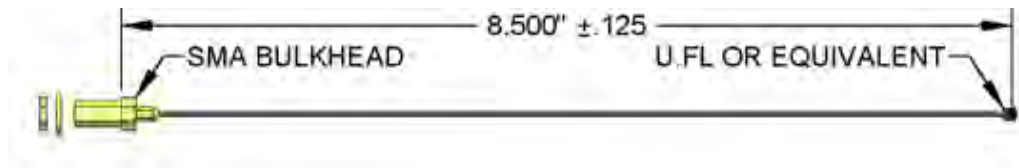

Optional antenna cables can be ordered from Multi-Tech Systems, Inc.

Part Number	Description
CASMA-UFL-1	SMA-to-UFL Coax Cable (Single Pack)
CASMA-UFL-10	SMA-to-UFL Coax Cable (Ten Pack)
CARSMA-UFL-1	RSMA-to-UFL Coax Cable (Single Pack)
CARSMA-UFL-10	RSMA-to-UFL Coax Cable (Ten Pack)

Antennas Available from Multi-Tech

Quad Band Description

Hinged Right Angle 800/900/1800/1900 MHz Cellular Antenna, 7.5"
 Hinged Right Angle 800/900/1800/1900 MHz Cellular Antenna, 7.5"
 Hinged Right Angle 800/900/1800/1900 MHz Cellular Antenna, 7.5"

Qty	Part Number
1	ANQB-1HRA
10	ANQB-10HRA
50	ANQB-50HRA

Dual Band Description

Hinged Right Angle 900/1800 MHz Cellular Antenna, 4"
 Hinged Right Angle 900/1800 MHz Cellular Antenna, 4"
 Hinged Right Angle 900/1800 MHz Cellular Antenna, 4"
 Hinged Right Angle 800/1900 MHz Cellular Antenna, 4"
 Hinged Right Angle 800/1900 MHz Cellular Antenna, 4"
 Hinged Right Angle 800/1900 MHz Cellular Antenna, 4"

Qty	Part Number
1	ANF1-1HRA
10	ANF1-10HRA
50	ANF1-50HRA
1	ANCF2-1HRA
10	ANCF2-10HRA
50	ANCF2-50HRA

Bluetooth and Wi-Fi Description

Hinged 2.4 MHz Bluetooth / Wi-Fi Antenna, 4"
 Hinged 2.4 MHz Bluetooth / Wi-Fi Antenna, 4"

Qty	Part Number
1	ANBT-1
10	ANBT-10

Mag Mount Dual Band Description

Mag Mount 900/1800 MHz 1/2 Wave Cellular Antenna, 12.5"
 Mag Mount 900/1800 MHz 1/2 Wave Cellular Antenna, 12.5"
 Mag Mount 900/1800 MHz 1/2 Wave Cellular Antenna, 12.5"
 Mag Mount 900/1800 MHz 1/4 Wave Cellular Antenna, 4"
 Mag Mount 900/1800 MHz 1/4 Wave Cellular Antenna, 4"
 Mag Mount 900/1800 MHz 1/4 Wave Cellular Antenna, 4"
 Mag Mount 900/1800 MHz 1/4 Wave Cellular Antenna, 4"
 Mag Mount 900/1800 MHz 1/4 Wave Cellular Antenna, 4"
 Mag Mount 850/1900 MHz 1/2 Wave Cellular Antenna, 12.5"
 Mag Mount 850/1900 MHz 1/2 Wave Cellular Antenna, 12.5"
 Mag Mount 850/1900 MHz 1/2 Wave Cellular Antenna, 12.5"
 Mag Mount 850/1900 MHz 1/4 Wave Cellular Antenna, 4"
 Mag Mount 850/1900 MHz 1/4 Wave Cellular Antenna, 4"
 Mag Mount 850/1900 MHz 1/4 Wave Cellular Antenna, 4"

Qty	Part Number
1	ANF1-1MMHW
10	ANF1-10MMHW
50	ANF1-50MMHW
1	ANF1-1MMQW
10	ANF1-10MMQW
50	ANF1-50MMQW
1	ANCF2-1MMHW
10	ANCF2-10MMHW
50	ANCF2-50MMHW
1	ANCF2-1MMQW
10	ANCF2-10MMQW
50	ANCF2-50MMQW

GPS Description

Mag Mount GPS Antenna, 5 Meter Cable
 Mag Mount GPS Antenna, 5 Meter Cable

Qty	Part Number
1	ANGPS-1MM
10	ANGPS-10MM

Additional Source of Wi-Fi Antennas

Wi-Fi antennas can be ordered from the following manufacturer:

Aristotle Enterprises <http://www.aristotle.com.tw/>

Part Number	Description
RFA-02-5-F7M3	2.4 GHz 5dBi Swi-Reverse-F Antenna

Additional Sources of Bluetooth Antennas

Bluetooth antennas can be ordered from the following manufacturers. For the manufacturers listed without specific part numbers, be sure to select the antenna that meets the requirements/specifications.

<http://www.nearson.com> (part number: S131AH-2450S)

<http://www.ead-ltd.com>

<http://www.lairdtech.com/Products/>

<http://www.mobilemark.com>

<http://www.woken.com.tw/>

Approved Antenna Cable Parts

GC Protronics: 20930C

Samtec: ASP-116785-01

The Coax Cable is an RG-178/U

Global Positioning System (GPS)

This information applies only to the SocketModem Cell & iCell GPRS with GPS (MTSMC-G2-GP) and the SocketModem® Cell and SocketModem iCell CDMA 1xRTT with GPS (MTSMC-C1-GP)

Technical Specifications

Receiver Type	L1 Frequency GPS C/A code SBAS Capable 51 Channel Acquisitions 14 Channel Tracking
Accuracy	Position 2.5m CEP Velocity 0.1m/sec Timing 300ns
Open Sky TTFF	Hot start 1 second Cold start 29 seconds average Reacquisition < 1s
Sensitivity Tracking	161dBm
Update Rate	1Hz standard
Dynamics	4G
Operational Limits	Altitude < 18,000m or Velocity < 515m/s
Datum	Default WGS-84
Interface	UART
Protocol	NMEA-0183 V3.01, GGA, GLL, GSA, GSV, RMC, VTG

Features

- Tests 8 million time-frequency hypothesis per sec
- Open sky cold start 29 second
- Signal detection better than –161dBm
- Reacquisition sensitivity –155dBm
- Accuracy 2.5m CEP
- Multipath detection and suppression
- Supports active or passive antenna

Underwriters Laboratories Required Global Positioning System (GPS) Statement

Note the following information required by Underwriters Laboratories:

Underwriters Laboratories, Inc. (“UL”) has not tested the performance or reliability of the Global Positioning System (“GPS”) hardware, operating software or other aspects of this product. UL has only tested for fire, shock or casualties as outlined in UL’s Standard(s) for Safety.UL60950-1 Certification does not cover the performance or reliability of the GPS hardware and GPS operating software. UL MAKES NO REPRESENTATIONS, WARRANTIES OR CERTIFICATIONS WHATSOEVER REGARDING THE PERFORMANCE OR RELIABILITY OF ANY GPS RELATED FUNCTIONS OF THIS PRODUCT.

Account Activation for Cellular Devices

Pre-Configured Multi-Tech Products

Some Multi-Tech cellular modems have been pre-configured to operate on a specific cellular network, such as Sprint and Verizon Wireless.

However, before you can begin to use the modem, you must set up a cellular data account with your cellular network provider. Then, follow the activation procedures covered on the Activation Notices available from Multi-Tech.

Cellular Approvals and Labeling Requirements

Approvals and Certification

The Multi-Tech SocketModem is Industry and/or Carrier Approved as an End Product modem. In most cases, when integrated and used with an antenna system that was part of the Multi-Tech modem certification, no additional approvals or certifications are required (however, CDMA has a few exceptions) for the device you develop as long as the following are met:

- PTCRB Requirements:**
 The antenna system **cannot** be altered.
- Model Identification:**

IMPORTANT
 When the cellular carrier asks you to provide the modem's model identification, give the Multi-Tech cellular model identification, not the identification of the host device model. See the label example below.

The Multi-Tech model identification allows the carrier to verify the modem as one of its approved models. This information is located on the modem's label.

The Following Is an Example of an End Product GPRS Label:

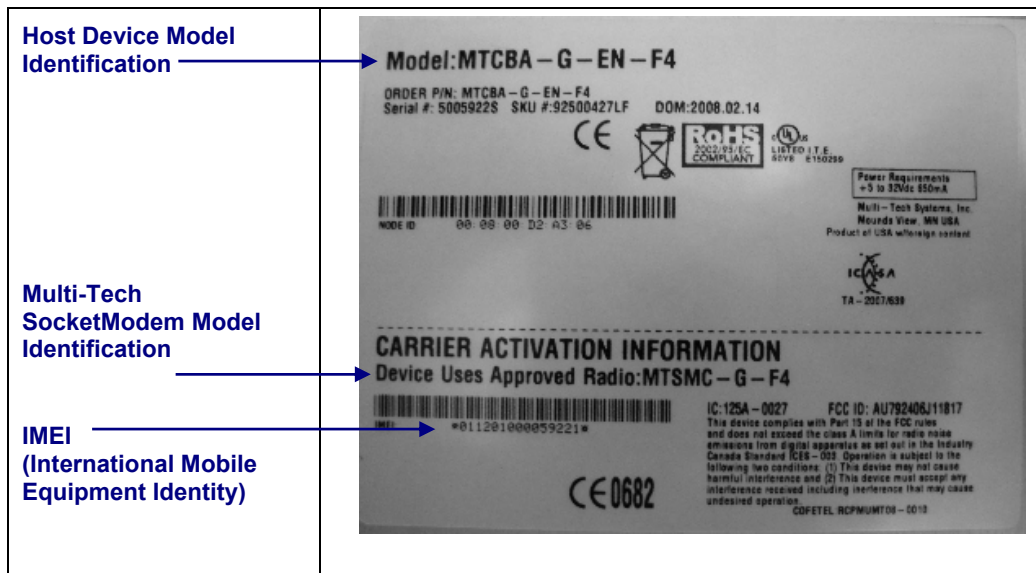

The Following Is an Example of a CDMA-C1 SocketModem Label:

Note: The label is shown larger than actual size.

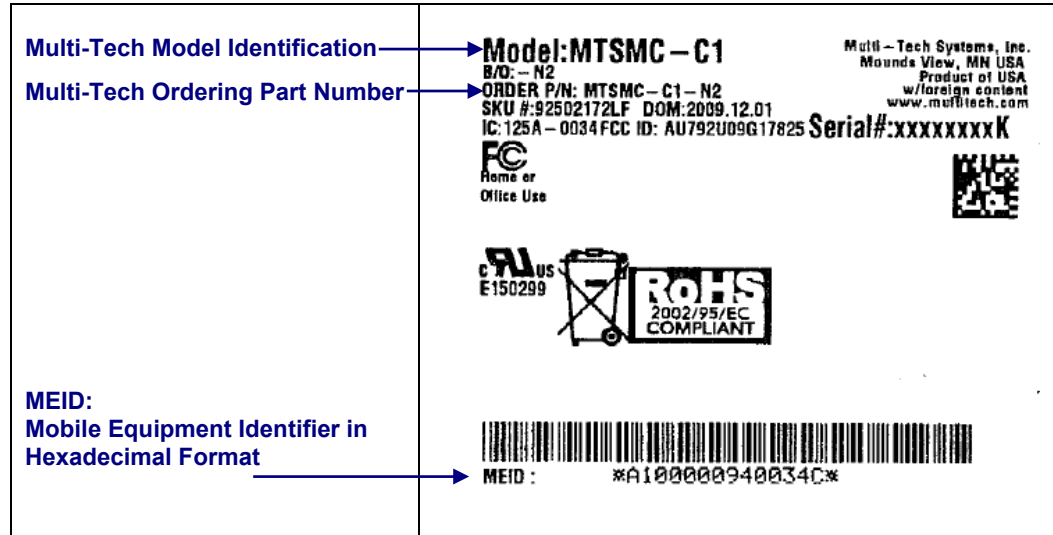

- **Other Information the Cellular Carrier Asks You to Provide:**

For CDMA SocketModems: The modem's MEID (Mobile Equipment Identifier) written in hexadecimal format is printed under the barcode on the modem.

For GSM SocketModems: The modem's 15-character IMEI (International Mobile Equipment Identity) number is printed on the modem's label.

Analog Information

Recommended Parts for Analog SocketModems

Disclaimer: Multi-Tech Systems makes no warranty claims for vendor product recommendations listed below. Other vendor products may or may not operate satisfactorily. Multi-Tech System's recommended vendor products only indicate that the product has been tested in controlled conditions and were found to perform satisfactorily.

Surface mount ferrites are used on T&R (Tip and Ring) to mitigate emission levels out the RJ-11 cable. 220pF capacitors are also used on T&R to reduce the common mode emissions that may be present in certain systems. See the Tip and Ring drawings in each analog SocketModem chapter.

The ferrite and capacitors also aid in reducing the effects of transients that may be present on the line.

Note: These parts are RoHS compliant.

Recommended Ferrite (SMT)

Manufacturer – Associated Component Technology (ACT) Part # CBZ1206-202-30-LF

Manufacturer – Murata Erie Part # BLM31AJ601SN1L

Recommended Ferrite (Thru-Hole)

Manufacturer – Associated Component Technology (ACT) Part # WB2-2.OT

Recommended Capacitor (SMT)

Manufacturer – NOVACAP

Part # ES2211N221K502NXT

Manufacturer – Murata Erie

Part # GA355DR7GC221KY02L

Recommended Capacitor (Thru-Hole)

Manufacturer – Ever Grace Electronic Industrials

Part # YP221K2EA7PS-8.0

Manufacturer – Murata Erie

Part # DE2B3KH221KA3B

Note: Capacitors used on T&R must have the Y2 safety rating.

Recommended RJ-11 Connector

Manufacturer – Full Rise Electronic Co.

Part # E5964-00P045

Recommended Sidactor

Manufacturer – RayChem / Tyco Electronics

Part # TVB400MSC-L

Manufacturer – ST Microelectronics

Part# SMPMC-400

Recommended Poly Switch Thermal Fuse (SMT)

Manufacturer – RayChem / Tyco Electronics

Part # TS600-170F

Recommended Poly Switch Thermal Fuse (Thru-Hole)

Manufacturer – RayChem (Tyco Electronics)

Part# TRF600-150

Note: The Fuse & Sidactor are required in order to comply with UL60950 for protection against over-voltages from power line cross. Fuse can be reset type.

Common Mode Choke

Manufacturer – TDK

Part # ZJYS51R5-2PT-01

Recommended Transceiver

Manufacturer – Analog Devices

Part # ADM207EARZ

SIP Connector

Manufacturer – Neltron Industrial Co. (<http://www.neltron.com.tw/>) Part #2209S-XXG

4-Pin 2.0mm SIP Socket (2 Each)

10-Pin 2.0mm SIP Socket (2 Each)

Telecom

The RJ-11 connector must meet FCC Part 68 requirements. Refer to FCC Part 68 section 68.500 subpart F for connector specifications. A self-healing fuse is used in series with line to help prevent damage to the DAA circuit. This fuse is required in order to meet compliance regulations.

Note: See *Application Notes* at the end of each SocketModem chapter.

Analog Labeling Requirements

United States Labeling Requirements (for Dial-Up Modems)

Telecom requirements apply to analog products only.

Approved terminal equipment and approved protective circuitry shall prominently display the following information using the format shown below:

- Responsible party or manufacturer
- Product Identification
- Equipment Code
- Ringer Equivalence
- Ringer Type
- Indication that the product meets the requirements of FCC Part 68

The information required by the first five items shall correspond to the records in the ACTA (America's Carriers Telecommunications Association) database of approved equipment. The required information shall be encoded in the following format:

US: AAAEQ##TXXX

Where:

US: Is a fixed field that indicates the equipment meets all requirements of 47 CFR Part 68, including the requirements published by ACTA (America's Carriers Telecommunications Association).

AAA is the responsible party's Grantee Code obtained previously from the FCC's Common Carrier Bureau or currently from ACTA.

EQ Is an Equipment Code indicating to the Service Provider any special signal handling or billing requirements. The Equipment codes are listed in Annex A (normative).

is the Ringer Equivalence Number without a decimal point (e.g. REN of 1.0 = 10, REN of 0.3 = 03). In the case of a "Z" ringer, ZZ shall appear. In the case of approved equipment without a network interface and equipment not connecting to circuits with analog ringing supplied then "NA" shall appear.

T is the ringer type letter associated with the Ringer Equivalence Number, in accordance with the technical requirements. In the case of approved equipment without a network interface and equipment not connecting to circuits with analog ringing supplied, the letter "N" shall appear.

XXX Is a product identifier, unique when combined with the responsible party's Grantee Code, of at least one and up to nine alphanumeric characters (including one or more dashes (-) if desired. A dash shall not appear as the first or last character nor shall the identifier consist entirely of dashes). The responsible party shall define this identifier.

Label Physical Characteristics

The information required above shall be permanently affixed and legible without magnification. It may be etched, engraved, stamped, indelibly printed, or otherwise permanently marked. Alternatively, the required information may be permanently marked on a nameplate of metal, plastic or other material fastened to the enclosure by welding, riveting or with a permanent adhesive. Such a nameplate shall be able to last for the expected lifetime of the equipment and shall not be readily detachable.

Labeling Continuity and Changes

The labeling content and format requirements in effect when a product was approved shall be effective for the life of the product. The labeling content and format requirements in effect at approval shall also continue to be effective for modified products. However, the responsible party shall have the option of conforming a product's labeling to current content and format requirements at any time.

Other Label Requirements

The label shall be placed in one of the following locations in a location where it can be found after installation:

- on an outside surface
- inside a readily available access door or panel
- on another readily accessible surface

For example, the label should not be placed on the rear of a permanently wall-mounted device in a manner such that it is not readily accessible.

Canadian Labeling Requirements (for Dial-Up Modems)

The following requirements are established under section 69.3 of the *Telecommunications Act* for purposes of section 5 of the *Telecommunications Apparatus Regulations*.

Registered equipment shall bear the following identifying marks, and the Declaring Party shall ensure that these marks are permanently affixed to the equipment:

- (a) The registration number — Specifications of this mark are given in the document: *Self-Marking of the Certification/Registration Number on Terminal Equipment — Application Procedure and Agreement*; and
- (b) The model identification number under which the product was registered.

A statement of compliance with Industry Canada requirements, such as the one given below, shall accompany each unit of equipment whether registered under this procedure or previously certified:

"This product meets the applicable Industry Canada technical specifications"

For terminal equipment intended for connection to loop-start or ground-start interfaces, the Ringer Equivalence Number (REN) must be calculated as per Section 1.8 of CS-03, Part I. A REN higher than that determined may be assigned by manufacturers to allow for production variations. The REN must be marked on the terminal equipment itself or added to the note below. A note similar to the following shall accompany each unit of equipment whether registered under this procedure or previously certified:

"The Ringer Equivalence Number is an indication of the maximum number of devices allowed to be connected to a telephone interface. The termination on an interface may consist of any combination of devices subject only to the requirement that the sum of the RENs of all the devices does not exceed five".

Pursuant to section 69.3 of the *Telecommunications Act*, certified or self-declared TE will bear a valid identifying certification number or registration number. The marking of the certification or registration number on the product shall be as follows:

- (a) TAC holder/DP will be responsible for permanently affixing the certification/registration number on the TE. The certification/registration number (see example below) identifies Certified or self-declared TE to the public, representatives of the telecommunications common carriers, the Department, and other interested parties. The letter height must be no less than 1.5 mm and the letters must be legible without magnification.
- (b) For integrated devices, e.g. a modem or one that is intended to become a sub-assembly of host equipment e.g. a data terminal, computer etc. that are designed to interface directly with the network, the certification/registration number shall be affixed to the integrated device itself.
- (c) The certification/registration number for a packaged TE will denote that the total package has been registered. However, the marking will normally be placed on that unit of the package which connects to the network; e.g., in a PBX the marking will be placed on the common equipment which connects to the network, rather than on plug-in components which may be added later. The Terminal Equipment List will show the common equipment but not the standard station apparatus or any proprietary station apparatus.
- (d) The marking format of the certification/registration number is as follows:
IC: XXXXXX-YYYYYYYY

Where:

- The letters "IC" have no other meaning or purpose than to identify the Industry Canada certification/registration number, and
- "XXXXXX-YYYYYYYY" is the certification/registration number; "XXXXXX" is the Company Number¹ (CN); it consists of up to six alphanumeric characters (A-Z, 0-9) assigned by Industry Canada; and "YYYYYYYY" is the Unique Product Number (UPN); it consists of up to eight alphanumeric characters (A-Z, 0-9) assigned by the applicant. Other characters, (such as & # *-) may not be used. Alphabetic characters must be capitalized.

¹ **Note:** The Company Number of registered equipment ends with an alphabetic character.

- (e) Certification Numbers granted prior to the implementation of the above marking format are grandfathered.
 - (i) For previously certified TE, the self-marking format shall consist of the old certification number preceded by "IC:" For example, if the certification number is "123 1234 A", then the self-mark would read "IC: 123 1234 A".
 - (ii) For a new model that is registered to a family of previously certified TE, the self-marking format shall be: IC: XXXXXX-ZZZZZZZZ

Where:

- "XXXXXX" is the Company Number, as in (d) above; and
- "ZZZZZZZZ" is either the old certification number minus the old company number, or a new Unique Product Number assigned by the applicant. For example, if a new model is registered to the family of products with certification number "123 1234 A", and that the Company Number for the registration is "123A", then the self-mark for this new model would read "IC: 123A-1234 A". If the applicant decides to replace "1234 A" with a new UPN, say "5678", then the self-mark would read "IC: 123A-5678".

Label Examples for Analog Socket Modems

Note: These do not apply to the Cellular GPRS and CDMA products.

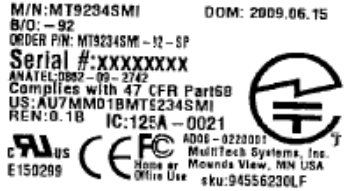
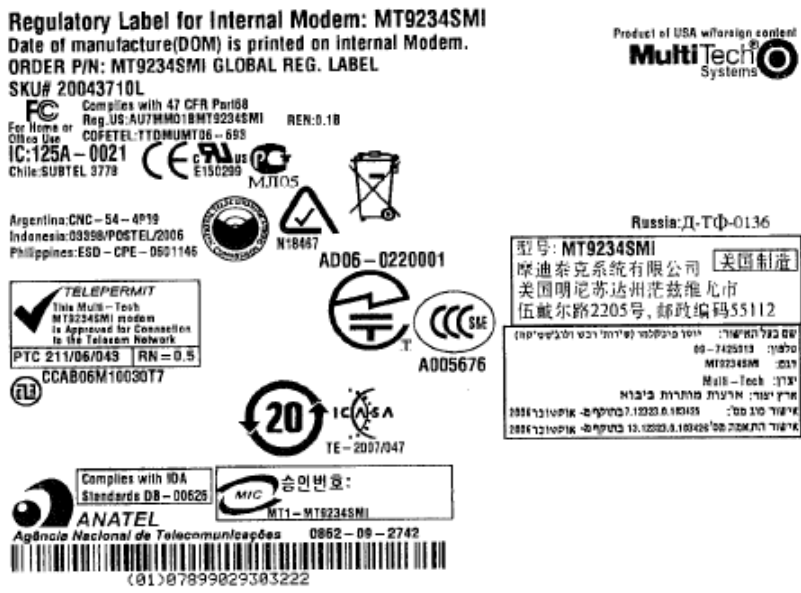
 <p>M/N: MT9234SMI DOM: 2009.06.15 B/O: - 92 ORDER P/N: MT9234SMI - 12 - SP Serial #: xxxxxxxx ANATEL: 0882 - 09 - 2742 Complies with 47 CFR Part 15B US: A07MM01BMT9234SMI REN: 0.1B IC: 125A - 0021 A006 - 0220001 MultiTech Systems, Inc. Mownda View, MN USA Home or Office Use sku: 94556230LF</p>	<p>Serial Label This label shows the modem model (M/N), build option (B/O), date of manufacture (DOM), serial number, and North America and European Union regulatory information.</p>
 <p>Regulatory Label for Internal Modem: MT9234SMI Date of manufacture (DOM) is printed on internal Modem. ORDER P/N: MT9234SMI GLOBAL REG. LABEL SKU# 20043710L Product of USA w/foreign content MultiTech Systems Complies with 47 CFR Part 15B Reg. US: A07MM01BMT9234SMI REN: 0.1B For Home or Office Use COPTEL: T10MUMT06 - 688 IC: 125A - 0021 E150299 Chile: SUBTEL 3778</p> <p>Argentina: CNC - 54 - 4P19 Indonesia: 03058/POSTEL/2006 Philippines: ESD - CPE - 0801146</p> <p>TELEPERMIT This Multi-Tech MT9234SMI modem is Approved for Connection to the Telecom Network PTC 211/06/043 RN = 0.9 CCAB06M10030T7</p> <p>Complies with IDA Standards DB - 00629 ANATEL Agência Nacional de Telecomunicações 0862 - 09 - 2742</p> <p>TE-2007/047</p> <p>승인번호: MT1 - MT9234SMI</p> <p>Russia: Д-ТФ-0136</p> <p>型号: MT9234SMI [美国制造] 摩迪泰克系统有限公司 美国明尼苏达州茨维尤市 伍戴尔路2205号, 邮政编码55112</p>	<p>This is an example of Regulatory Label which is available from Multi-Tech by request.</p>

Safety Notices and Warnings

Note to OEMs: The following safety statements may be used in the documentation of your final product applications.

Cellular Safety

General Safety

The modem is designed for and intended to be used in fixed and mobile applications. “Fixed” means that the device is physically secured at one location and is not able to be easily moved to another location. “Mobile” means that the device is designed to be used in other than fixed locations.

RF Safety

The remote modems are cellular telephones devices. It is important to follow any special regulations regarding the use of radio equipment due in particular to the possibility of Radio Frequency (RF) interference.

Caution: A separation distance of at least 20 cm must be maintained between the modem transmitter’s antenna and the body of the user or nearby persons. The modem is not designed for or intended to be used in portable applications within 20 cm of the body of the user. In particular, if using a Yagi antenna, it must be in a location that prevents public exposure to the radiation limits being exceeded. Check your local standards regarding safe distances, etc.

- Cellular modems in an ATM in, for example, a hospital environment and any other place where medical equipment may be in use, may be a hazard. This statement also applies to inadequately protected personal medical devices such as hearing aids and pacemakers.
- Operation of a cellular modem close to other electronic equipment may also cause interference if the equipment is inadequately protected. Observe any warning signs and manufacturers’ recommendations.
- The modems must not be operated around gasoline or diesel-fuel.

RF Interference Safety

It is important to follow any special regulations regarding the use of radio equipment due in particular to the possibility of radio frequency, RF, interference. Please follow the safety advice given below carefully.

- Switch OFF your Cellular MultiModem when in an aircraft. The use of cellular telephones in an aircraft may endanger the operation of the aircraft, disrupt the cellular network and is illegal. Failure to observe this instruction may lead to suspension or denial of cellular telephone services to the offender, or legal action or both.
- Switch OFF your Cellular MultiModem when around gasoline or diesel-fuel pumps and before filling your vehicle with fuel.
- Switch OFF your cellular device in hospitals and any other place where medical equipment may be in use.
- Respect restrictions on the use of radio equipment in fuel depots, chemical plants or where blasting operations are in progress.
- There may be a hazard associated with the operation of your cellular device close to inadequately protected personal medical devices such as hearing aids and pacemakers. Consult the manufacturers of the medical device to determine if it is adequately protected.
- Operation of your cellular device close to other electronic equipment may also cause interference if the equipment is inadequately protected. Observe any warning signs and manufacturers’ recommendations.

Vehicle Safety

- Do not use your cellular device while driving.
- Respect national regulations on the use of cellular telephones in vehicles. Road safety always comes first.
- If incorrectly installed in a vehicle, the operation of a cellular telephone could interfere with the correct functioning of vehicle electronics. To avoid such problems, be sure that qualified personnel have performed the installation. Verification of the protection of vehicle electronics should be part of the installation.
- The use of an alert device to operate a vehicle’s lights or horn on public roads is not permitted.

Maintenance of Your Cellular Device

Your cellular device is the product of advanced engineering, design, and craftsmanship and should be treated with care. The suggestions below will help you to enjoy this product for many years.

- Do not attempt to disassemble the cellular device. There are no user serviceable parts inside.
- Do not expose the cellular device to water, rain, or spilled beverages. It is not waterproof.
- Do not place the cellular device alongside computer discs, credit or travel cards, or other magnetic media. The phone may affect the information contained on discs or cards.
- The use of accessories not authorized by Multi-Tech or not compliant with Multi-Tech's accessory specifications may invalidate the warranty of the cellular device.
- In the unlikely event of a fault in the cellular device, contact Multi-Tech Tech Support.

Your Responsibility

This cellular device is your responsibility. Please treat it with care respecting all local regulations. It is not a toy. Therefore, keep it in a safe place at all times and out of the reach of children.

Try to remember your Unlock and PIN codes. Become familiar with and use the security features to block unauthorized use and theft.

Analog Telecom Safety Warnings

1. Never install telephone wiring during a lightning storm.
2. Never install a telephone jack in wet locations unless the jack is specifically designed for wet locations.
3. This product is to be used with UL and cUL listed computers.
4. Never touch uninsulated telephone wires or terminals unless the telephone line has been disconnected at the network interface.
5. Use caution when installing or modifying telephone lines.
6. Avoid using a telephone during an electrical storm. There may be a remote risk of electrical shock from lightning.
7. Do not use a telephone in the vicinity of a gas leak.
8. To reduce the risk of fire, use only 26 AWG or larger telecommunication line cord.
9. This product must be disconnected from its power source and telephone network interface when servicing.

Telecom Approvals for Analog Modems

Multi-Tech's analog global* SocketModems are designed and approved for connection to the public switched telephone network in more than 50 countries or regions worldwide. Multi-Tech's SocketModems have been approved as host independent, which means our certification efforts can be transferred directly to your end product with proper labeling on the OEM equipment. Multi-Tech supports our approvals by supplying our customers with supporting documentation and offering a compliance label with country or regional approval logos and approval numbers to be attached to an end product.

Multi-Tech completes testing and obtains** certification test reports or certificates at or near the initial release of the product. After the initial release, the product may be tested and certified for other countries or regions. Check the Multi-Tech Systems, Inc. Web site at

http://www.multitech.com/en_US/PRODUCTS/Categories/Device_Networking/global_modems/approvals.aspx

or contact Multi-Tech at oemsales@multitech.com to obtain a current list of approvals for the SocketModem.

Note: Setting Country/Regional Codes – Country or Regional Codes are usually set through AT Commands. See each product's AT Command guide.

- * Refer to each chapter for Product Ordering Information identifying the modem as global or regional.
- ** Some countries or regions have special import requirements that require us to facilitate additional paperwork application in partner with our customers. Contact Multi-Tech at oemsales@multitech.com for more information.

Regulatory Compliance Statements

Country/Region-Specific Statements



EMC, Safety, and R&TTE Directive Compliance

The CE mark is affixed to this product to confirm compliance with the following European Community Directives:

Council Directive 2004/108/EC of 15 December 2004 on the approximation of the laws of Member States relating to electromagnetic compatibility;

and

Council Directive 2006/95/EC of 12 December 2006 on the harmonization of the laws of Member States relating to electrical equipment designed for use within certain voltage limits;

and

Council Directive 1999/5/EC of 9 March 1999 on radio equipment and telecommunications terminal equipment and the mutual recognition of their conformity.

International Modem Restrictions

Some dialing and answering defaults and restrictions may vary for international modems. Changing settings may cause a modem to become non-compliant with national telecom requirements in specific countries. Also note that some software packages may have features or lack restrictions that may cause the modem to become non-compliant.

EMC Requirements for the United States

47 CFR – FCC Part 15 Regulation

This equipment has been tested and found to comply with the limits for a **Class B** digital device, pursuant to 47 CFR – FCC Part 15 regulations. The stated limits in this regulation are designed to provide reasonable protection against harmful interference in a residential environment. This equipment generates, uses, and can radiate radio frequency energy, and if not installed and used in accordance with the instructions, may cause harmful interference to radio communications. However, there is no guarantee that interference will not occur in a particular installation. If this equipment does cause harmful interference to radio or television reception, which can be determined by turning the equipment off and on, the user is encouraged to try to correct the interference by one or more of the following measures:

- Reorient or relocate the receiving antenna.
- Increase the separation between the equipment and receiver.
- Plug the equipment into an outlet on a circuit different from that to which the receiver is connected.
- Consult the dealer or an experienced radio/TV technician for help.

This device complies with 47 CFR – FCC Part 15 rules. Operation of this device is subject to the following conditions:

- (1) This device may not cause harmful interference, and
- (2) This device must accept any interference that may cause undesired operation.

Warning: Changes or modifications to this unit not expressly approved by the party responsible for compliance could void the user's authority to operate the equipment.

EMC Requirements for Industry Canada

This Class B digital apparatus meets all requirements of the Canadian Interference-Causing Equipment Regulations.

Cet appareil numérique de la classe B respecte toutes les exigences du Règlement Canadien sur le matériel brouilleur.

47 CFR Part 68 Telecom

1. This equipment complies with Part 68 of the 47 CFR rules and the requirements adopted by the ACTA. Located on this equipment is a label that contains, among other information, the registration number and ringer equivalence number (REN) for this equipment or a product identifier in the format:
 - For current products is **US:AAAEQ##Txxxx**.
 - For legacy products is **AU7USA-xxxxx-xx-x**.
 If requested, this number must be provided to the telephone company.
2. A plug and jack used to connect this equipment to the premises wiring and telephone network must comply with the applicable 47 CFR Part 68 rules and requirements adopted by the ACTA. It's designed to be connected to a compatible modular jack that is also compliant.
3. The ringer equivalence number (REN) is used to determine the number of devices that may be connected to a telephone line. Excessive RENs on a telephone line may result in the devices not ringing in response to an incoming call. In most but not all areas, the sum of RENs should not exceed five (5.0). To be certain of the number of devices that may be connected to a line, as determined by the total RENs, contact the local telephone company. For products approved after July 23, 2001, the REN for this product is part of the product identifier that has the format US:AAAEQ##Txxxx. The digits represented by ## are the REN without a decimal point (e.g., 03 is a REN of 0.3). For earlier products, the REN is separately shown on the label.
4. If this equipment causes harm to the telephone network, the telephone company will notify you in advance that temporary discontinuance of service may be required. But if advance notice isn't practical, the telephone company will notify the customer as soon as possible. Also, you will be advised of your right to file a complaint with the FCC if you believe it is necessary.
5. The telephone company may make changes in its facilities, equipment, operations or procedures that could affect the operation of the equipment. If this happens, the telephone company will provide advance notice in order for you to make necessary modifications to maintain uninterrupted service.
6. If trouble is experienced with this equipment, please contact Multi-Tech Systems, Inc. at the address shown below for details of how to have the repairs made. If the equipment is causing harm to the telephone network, the telephone company may request that you disconnect the equipment until the problem is resolved.
7. Connection to party line service is subject to state tariffs. Contact the state public utility commission, public service commission or corporation commission for information.
8. No repairs are to be made by you. Repairs are to be made only by Multi-Tech Systems or its licensees. Unauthorized repairs void registration and warranty.
9. If your home has specially wired alarm equipment connected to the telephone line, ensure the installation of this equipment does not disable your alarm equipment.
If you have questions about what will disable alarm equipment, consult your telephone company or a qualified installer.
10. Connection to party line service is subject to state tariffs. Contact the state public utility commission, public service commission or corporation commission for information.
11. This equipment is hearing aid compatible.
12. Manufacturing Information on telecommunications device (modem):

Manufacturer:	Multi-Tech Systems, Inc.		
Trade Name:	Socket Modem	SocketModem	SocketModem
Model Number:	MT9234SMI	MT5692SMI	MT2492SMI
Registration No:	US:AU7MM01BMT9234SMI	US:AU7MM01BMT5692SMI	US:AU7MM01B2492SMI
Ringer Equivalence:	0.1B		
Modular Jack (USOC):	RJ11C or RJ11W (single line)		
Service Center in USA:	Multi-Tech Systems, Inc. 2205 Woodale Drive Mounds View, MN 55112 U.S.A. (763) 785-3500 (763) 785-9874 Fax		

New Zealand Telecom Warning Notice

1. The grant of a Telepermit for any item of terminal equipment indicates only that Telecom has accepted that the item complies with minimum conditions for connection to its network. It indicates no endorsement of the product by Telecom, nor does it provide any sort of warranty. Above all, it provides no assurance that any item will work correctly in all respects with another item of Telepermitted equipment of a different make or model, nor does it imply that any product is compatible with all of Telecom's network services.
This equipment is not capable under all operating conditions of correct operating conditions of correct operation at the higher speed which it is designated. 33.6 kbps and 56 kbps connections are likely to be restricted to lower bit rates when connected to some PSTN implementations. Telecom will accept no responsibility should difficulties arise in such circumstances.
2. Immediately disconnect this equipment should it become physically damaged, and arrange for its disposal or repair.
3. This modem shall not be used in any manner which could constitute a nuisance to other Telecom customers.
4. This device is equipped with pulse dialing, while the Telecom standard is DTMF tone dialing. There is no guarantee that Telecom lines will always continue to support pulse dialing.
Use of pulse dialing, when this equipment is connected to the same line as other equipment, may give rise to 'bell tinkle' or noise and may also cause a false answer condition. Should such problems occur, the user should NOT contact the Telecom Faults Service.
The preferred method of dialing is to use DTMF tones, as this is faster than pulse (decadic) dialing and is readily available on almost all New Zealand telephone exchanges.
5. Warning Notice: No '111' or other calls can be made from this device during a mains power failure.
6. This equipment may not provide for the effective hand-over of a call to another device connected to the same line.
7. Some parameters required for compliance with Telecom's Telepermit requirements are dependent on the equipment (PC) associated with this device. The associated equipment shall be set to operate within the following limits for compliance with Telecom's Specifications:
For repeat calls to the same number:
 - There shall be no more than 10 call attempts to the same number within any 30 minute period for any single manual call initiation, and
 - The equipment shall go on-hook for a period of not less than 30 seconds between the end of one attempt and the beginning of the next attempt.
 For automatic calls to different numbers:
 - The equipment shall be set to ensure that automatic calls to different numbers are spaced such that there is no less than 5 seconds between the end of one call attempt and the beginning of another.
8. For correct operation, total of the RN's of all devices connected to a single line at any time should not exceed 5.

South African Statement

This modem must be used in conjunction with an approved surge protection device.

Thailand Approval for MT9234SMI and the MT5692SMI

This telecom device conforms to NTC* requirements.

**NTC is the National Telecommunications Commission, Thailand's telecommunications regulator.*

“เครื่องโทรคมนาคมและอุปกรณ์นี้ มีความสอดคล้องตามข้อกำหนดของ กทช.”

Brazil Approval for the MT9234SMI

This product has been homologated by ANATEL. This product meets the applied technical requirements in accordance with the procedures regulated by ANATEL. Reference of homologation of this product can be viewed in ANATEL web page: <http://www.anatel.gov.br>



Brazil Bar Code for MT9234SMI

Brazil Certification

A special phone cable is required for regulatory compliance.

Um cabo especial para telefone é requerido para a conformidade regulatória.

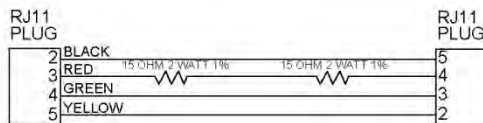

Japan Requirements

These devices conform to (JATE) Japan Approval Institute for Telecommunications Equipment:

MT5692SMI – JATE Approval A09-0123001

MT9234SMI – JATE Approval AD06-0220001

Important Note: SocketModems are approved for product development in Japan only if they are removable from the manufactured product. The SocketModem must not be soldered into place.



Japan requires that your manufactured product documentation include SocketModem installation and removal instructions as well as connection to the PSTN network. The following text provides general steps to follow.

Installation of the SocketModem into Your Manufactured Product

1. If applicable, disconnect any power cord and peripherals you may have attached to your manufactured product.
2. Place the SocketModem on the board of your product. Be sure to match the pins on the SocketModem with the correct orientation on your board.
3. Be sure that the SocketModem is securely fastened to board so that it cannot come loose while handling or during shipping. Some examples of fasteners include nylon screws, tie wraps, etc. **Remember that you cannot solder the SocketModem in place.**
4. Put the cover on your product and connect the power and peripherals.

Removal of the SocketModem from Your Manufactured Product

1. Back up the current configuration of your manufactured product if you want to save it.
2. Record any information not stored in the configuration that you may want to reference.
3. Disconnect any power cord and peripherals from your manufactured product.
4. Remove the cover from your product.
5. To remove the SocketModem, gently lift the SocketModem upwards while holding the board in place.

Connecting to the PSTN Network

For connection to a PSTN network, see the *Tip and Ring Interface* section in each analog SocketModem chapter.

Other Countries

The above country-specific examples do not cover all countries with specific regulations; they have been included to show you how each country may differ. If you have trouble determining your own country's requirements, check with Multi-Tech's Technical Support for assistance.

Waste Electrical and Electronic Equipment Statement

Note to OEMs: The statement is included for your information and may be used in the documentation of your final product applications.

WEEE Directive

The WEEE directive places an obligation on EU-based manufacturers, distributors, retailers, and importers to take-back electronics products at the end of their useful life. A sister Directive, ROHS (Restriction of Hazardous Substances) complements the WEEE Directive by banning the presence of specific hazardous substances in the products at the design phase. The WEEE Directive covers all Multi-Tech products imported into the EU as of August 13, 2005. EU-based manufacturers, distributors, retailers and importers are obliged to finance the costs of recovery from municipal collection points, reuse, and recycling of specified percentages per the WEEE requirements.

Instructions for Disposal of WEEE by Users in the European Union

The symbol shown below is on the product or on its packaging, which indicates that this product must not be disposed of with other waste. Instead, it is the user's responsibility to dispose of their waste equipment by handing it over to a designated collection point for the recycling of waste electrical and electronic equipment. The separate collection and recycling of your waste equipment at the time of disposal will help to conserve natural resources and ensure that it is recycled in a manner that protects human health and the environment. For more information about where you can drop off your waste equipment for recycling, please contact your local city office, your household waste disposal service or where you purchased the product.

July, 2005



Restriction of the Use of Hazardous Substances (RoHS)



Multi-Tech Systems, Inc. Certificate of Compliance 2002/95/EC

Multi-Tech Systems Inc. confirms that its embedded products now comply with the chemical concentration limitations set forth in the directive **2002/95/EC** of the European Parliament (Restriction Of the use of certain Hazardous Substances in electrical and electronic equipment - **RoHS**)

These Multi-Tech Systems, Inc. products do not contain the following banned chemicals:

- Lead, [Pb] < 1000 PPM
- Mercury, [Hg] < 1000 PPM
- Hexavalent Chromium, [Cr+6] < 1000 PPM
- Cadmium, [Cd] < 100 PPM
- Polybrominated Biphenyl, [PBB] < 1000 PPM
- Polybrominated Diphenyl Ether, [PBDE] < 1000 PPM

Moisture Sensitivity Level (MSL) =1
Maximum Soldering temperature = 260C (wave only)

Notes:

- 1.** Lead usage in some components is exempted by the following RoHS annex; therefore, higher lead concentration would be found in some SocketModems (>1000ppm).
 - a. Lead in high melting temperature type solders (i.e., tin-lead solder alloys containing more than 85% lead).
 - b. Lead in electronic ceramic parts (e.g., piezoelectronic devices).
- 2.** Moisture Sensitivity Level (MSL) – Analysis is based on the components/material used on the board.

Information on HS/TS Substances According to Chinese Standards in English

In accordance with China's Administrative Measures on the Control of Pollution Caused by Electronic Information Products (EIP) # 39, also known as China RoHS, the following information is provided regarding the names and concentration levels of Toxic Substances (TS) or Hazardous Substances (HS) which may be contained in Multi-Tech Systems Inc. products relative to the EIP standards set by China's Ministry of Information Industry (MII).

Name of the Component	Hazardous/Toxic Substance/Elements					
	Lead (PB)	Mercury (Hg)	Cadmium (CD)	Hexavalent Chromium (CR6+)	Polybrominated Biphenyl (PBB)	Polybrominated Diphenyl Ether (PBDE)
Printed Circuit Boards	O	O	O	O	O	O
Resistors	X	O	O	O	O	O
Capacitors	X	O	O	O	O	O
Ferrite Beads	O	O	O	O	O	O
Relays/Opticals	O	O	O	O	O	O
ICs	O	O	O	O	O	O
Diodes/ Transistors	O	O	O	O	O	O
Oscillators and Crystals	X	O	O	O	O	O
Regulator	O	O	O	O	O	O
Voltage Sensor	O	O	O	O	O	O
Transformer	O	O	O	O	O	O
Speaker	O	O	O	O	O	O
Connectors	O	O	O	O	O	O
LEDs	O	O	O	O	O	O
Screws, Nuts, and other Hardware	X	O	O	O	O	O
ac-dc Power Supplies	O	O	O	O	O	O
Software / Documentation CDs	O	O	O	O	O	O
Booklets and Paperwork	O	O	O	O	O	O
Chassis	O	O	O	O	O	O

- X** Represents that the concentration of such hazardous/toxic substance in all the units of homogeneous material of such component is higher than the SJ/Txxx-2006 Requirements for Concentration Limits.
- O** Represents that no such substances are used or that the concentration is within the aforementioned limits.

Information on HS/TS Substances According to Chinese Standards in Chinese

依照中国标准的有毒有害物质信息

根据中华人民共和国信息产业部 (MII) 制定的电子信息产品 (EIP)

标准 - 中华人民共和国《电子信息产品污染控制管理办法》(第 39 号), 也称作中国

RoHS, 下表列出了 Multi-Tech Systems, Inc. 产品中可能含有的有毒物质 (TS) 或有害物质 (HS) 的名称及含量水平方面的信息。

成分名称	有害/有毒物质/元素					
	铅 (PB)	汞 (Hg)	镉 (CD)	六价铬 (CR6+)	多溴联苯 (PBB)	多溴二苯醚 (PBDE)
印刷电路板	○	○	○	○	○	○
电阻器	X	○	○	○	○	○
电容器	X	○	○	○	○	○
铁氧体磁环	○	○	○	○	○	○
继电器/光学部件	○	○	○	○	○	○
IC	○	○	○	○	○	○
二极管/晶体管	○	○	○	○	○	○
振荡器和晶振	X	○	○	○	○	○
调节器	○	○	○	○	○	○
电压传感器	○	○	○	○	○	○
变压器	○	○	○	○	○	○
扬声器	○	○	○	○	○	○
连接器	○	○	○	○	○	○
LED	○	○	○	○	○	○
螺丝、螺母以及其它五金件	X	○	○	○	○	○
交流-直流电源	○	○	○	○	○	○
软件/文档 CD	○	○	○	○	○	○
手册和纸页	○	○	○	○	○	○
底盘	○	○	○	○	○	○

X 表示所有使用类似材料的设备中有害/有毒物质的含量水平高于 SJ/Txxx-2006 限量要求。

○ 表示不含该物质或者该物质的含量水平在上述限量要求之内。

Part 2
Cellular SocketModems

- Chapter 2 – SocketModem Cell and iCell (GPRS)**
- Chapter 3 – SocketModem Cell and iCell (CDMA 1xRTT)**
- Chapter 4 – SocketModem EDGE**
- Chapter 5 – SocketModem HSDPA**

Chapter 2 – SocketModem[®] Cell & SocketModem[®] iCell GPRS (MTSMC-G2)

Introduction

The MTSMC-G2 is a serial to cellular quad-band GPRS SocketModem. It is a complete, ready-to-integrate SocketModem that offers standards-based multi-band GSM/GPRS Class 10 performance. It is based on industry-standard open interfaces and utilizes Multi-Tech's universal socket design. The SocketModem is available with the Multi-Tech's *Universal IP*[™] stack to bring embedded Internet connectivity to any device.

Notes about Activation:

- These units are shipped without network activation.
- To connect to the cellular network, you will have to establish a cellular account. See the Cellular Activation procedures on separate sheets included with the Developer Kit and available on the Developer Kit CD.

Product Build Options and Ordering Information

Product	Description	Region	Order This Product ✓
MTSMC-G2	Quad-band SocketModem Cell GPRS	US Default	
MTSMC-G2-ED	Quad-band SocketModem Cell GPRS	EU Default	
MTSMC-G2-V	Quad-band SocketModem Cell GPRS with Voice	US Default	
MTSMC-G2-V-ED	Quad-band SocketModem Cell GPRS with Voice	EU Default	
MTSMC-G2-IP	Quad-band SocketModem iCell GPRS with Universal IP	US Default	
MTSMC-G2-IP-ED	Quad-band SocketModem iCell GPRS with Universal IP	EU Default	
MTSMC-G2-GP	Quad-band SocketModem Cell GPRS with GPS with Universal IP	US Default	
MTSMC-G2-GP-ED	Quad-band SocketModem Cell GPRS with GPS with Universal IP	EU Default	
Developer Kit			
MTSMI-UDK	Universal Developer Kit	Global	

How to Read the Product Codes in the Table Above:

G2	GPRS
GP	Dedicated GPS Receiver
ED	European Default is 900/1800 MHz Note: US Default is 850/1900 MHz
V	Voice (microphone and speaker)
IP	Universal IP [™] Stack
UDK	Universal Developer Kit

Other Product Codes:

The complete product code may end in **.Rx**. For example, MTSMC-G2.Rx.

"R" indicates product revision. "x" is the revision number.

Note: All products can be ordered in single packs or 50-packs. Single pack product codes end in **SP**.

AT Commands Reference Guides

Products	AT Commands Reference Guide Title & Document Number	Fax Commands	Voice Commands
SocketModem Cell (MTSMC-G2 and MTSMC-G2-V)	GPRS AT Commands for Multi-Tech G2 Cellular Modems (S000463x) AT Commands for Multi-Tech G2 Cellular Modems with IP Connectivity (S000469x)	NA	For G2-V (Voice) build only
SocketModem iCell (MTSMC-G2-IP & MTSMC-G2-GP)	GPRS AT Commands for Multi-Tech G2 Cellular Modems (S000463x) Universal IP Commands (S000457x)	NA	For G2-V (Voice) build only

Technical Specifications

The SocketModem Cell and SocketModem iCell (MTSMC-G2 and MTSMC-G2-V) meet the following specifications:

Category	Description
Standards	GPRS Class 10
Frequency Bands	Quad-band GSM/EGPRS 850/900/1800/1900 MHz
Serial/Data Speed	Serial interface supports DTE speeds up to 921.6K IP interface supports DTE speeds at the fixed rate of 115.2 Packet data up to 85.6K bps Circuit-switched data (GPRS) up to 14.4K bps transparent and non-transparent Supports data rates of 921600, 460800, 230400, 115200 bps
Data Format	10 bit Serial Asynchronous
Data Error Correction	MNP2
Data Compression	V.42bis
Weight	1 oz. (28 g)
Size	3.15" x 1.375" (80.010 mm x 34.925 mm)
Operating Temperature	-40° C to +85° C
Storage Temperature	-40 °C to +85°C
Humidity	10% to 90%
Input Power	5VDC
Operating Voltage	Supply Range: VCC Maximum: 5.5
Voltage at Any Signal Pin	Minimum: GND Maximum: VCC
Antenna Connector	Surface mount UFL (one for cellular and one for GPS)
SIM Holder	Standard 1.8V and 3V SIM holder
IP Protocols Supported	MTSMC-G2, MTSMC-G2-V DNS Resolve, FTP Client, LCP, PPP (dial-out),TCP socket, UDP socket, PAP & CHAP authentication MTSMC-G2-IP, MTSMC-G2-GP DNS Client, FTP Client, ICMP (Ping), POP3 Client, SMTP Client, TCP Client & Server, UDP Client & Server, IP, PPP (dial-out) with PAP & CHAP authentication
M2M Applications	MTSMC-G2-IP, MTSMC-G2-GP Automatic connect/reconnect, device monitor, modem emulation, Ping & TCP keep alive, wake-up on caller ID, wake-up on ring, GPS tracking (GP model only)
Compliance	EMC Compliance FCC Part 15 EN55022 EN55024 Radio Compliance FCC Part 22 FCC Part 24 RSS 132 RSS 133 EN 301 511 EN 301 489-1 EN 301 489-7 AS/ACIF S042.1 AS/ACIF S042.3 Safety Compliance UL 60950-1 cUL 60950-1 IEC 60950-1 AS/NZS 60950-1 Network Compliance PTCRB
Warranty	Two years

Note: The radio's performance may be affected at the temperature extremes. This is considered normal. The radio is designed to automatically fallback in class and reduces transmitter power to avoid damage to the radio. There is no single cause for this function. Rather, it is the result of an interaction of several factors, such as the ambient temperature, the operating mode and the transmit power.

Important

MTSMC Tooling Holes and Mounting Hardware

It is recommended that nylon hardware be used if the SocketModems are to be mounted using the two tooling holes due to possible traces and vias around the tooling holes. #4 or M2/M3 hardware should be used for mounting.

This applies to the SocketModem® Cell & SocketModem® iCell GPRS (MTSMC-G2)

Note: See the Mechanical Drawings for MTSMC-G2 on the following four pages.

Mechanical Drawings – Basic Build

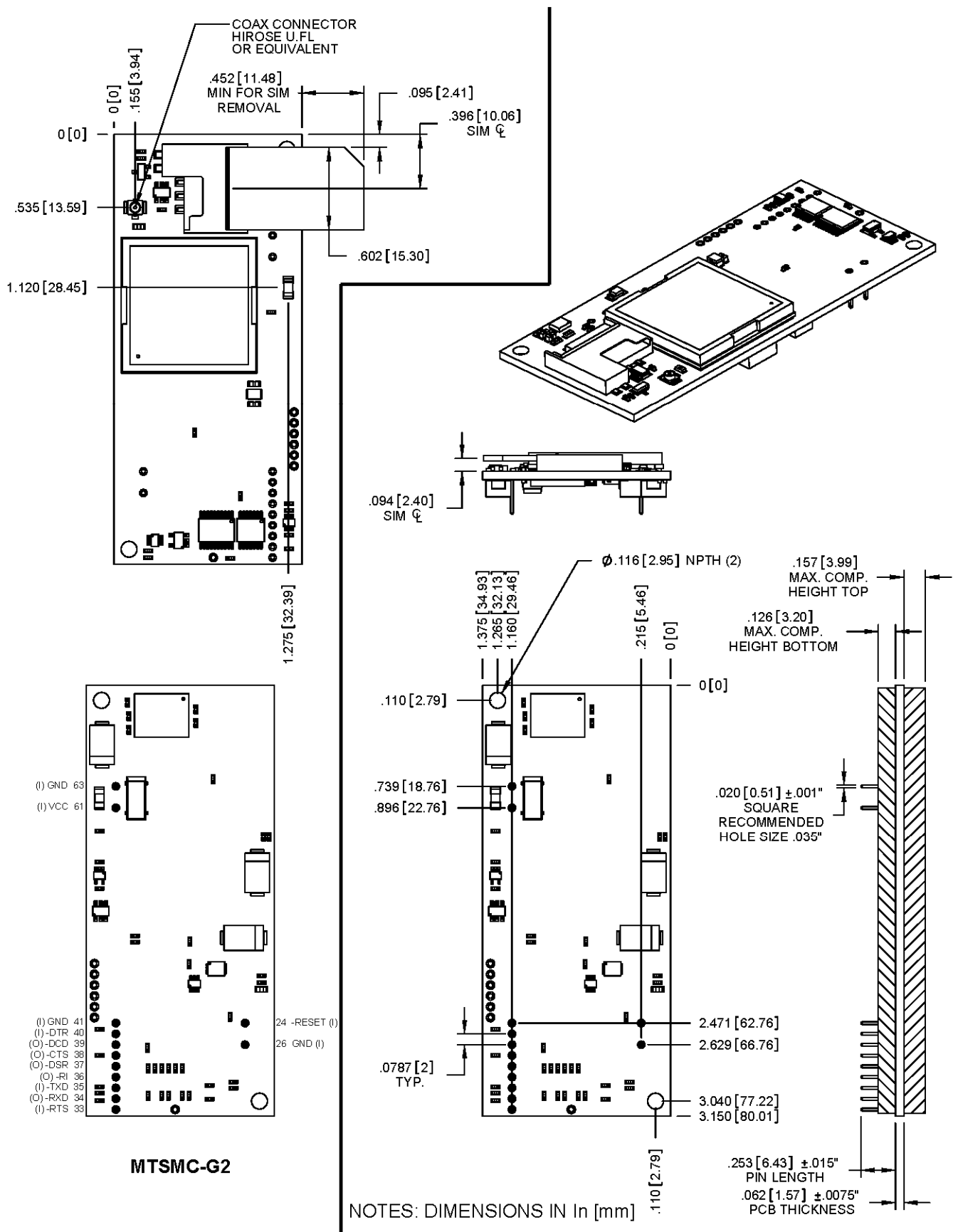

Mechanical Drawings – Voice Build

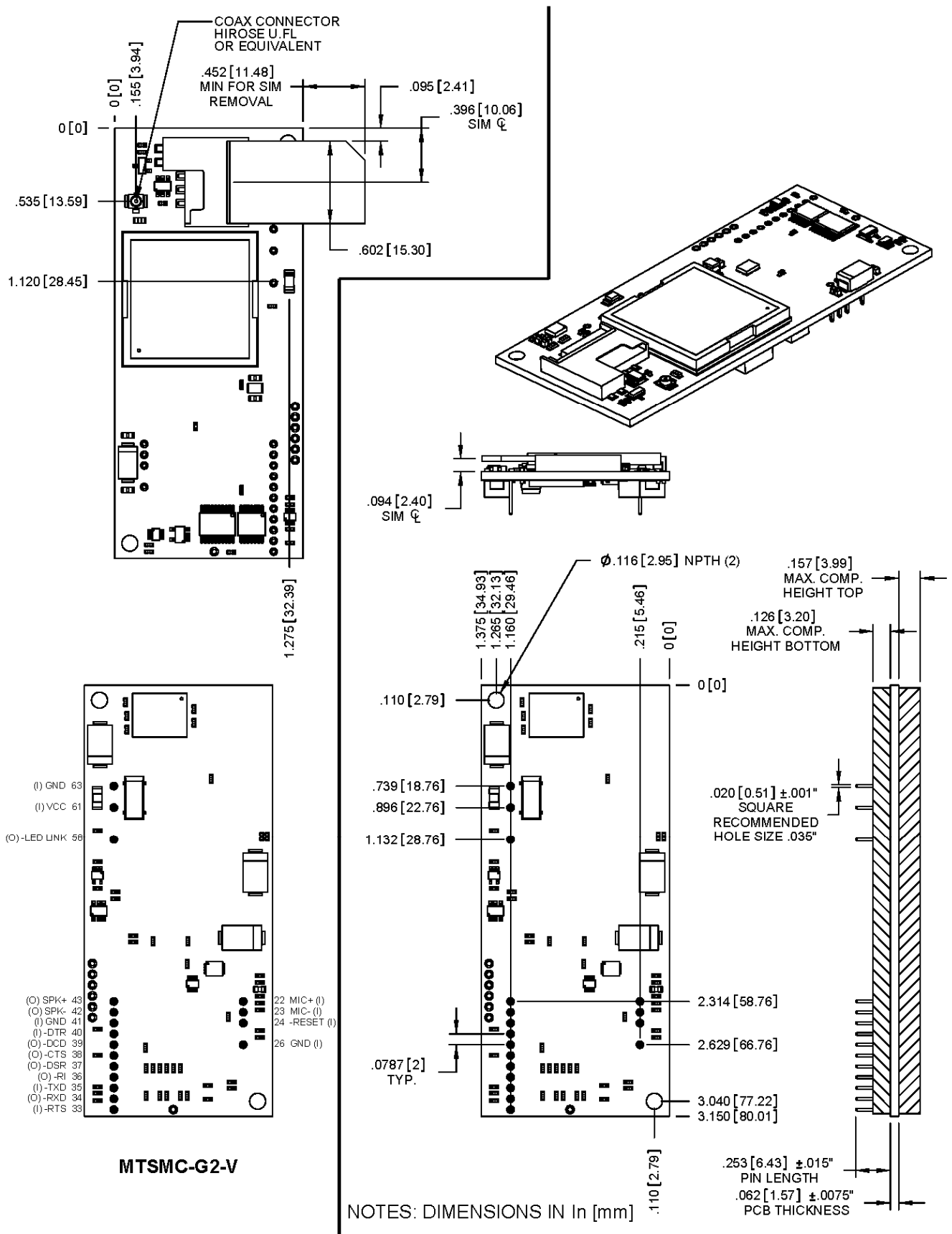

Mechanical Drawings – IP Build

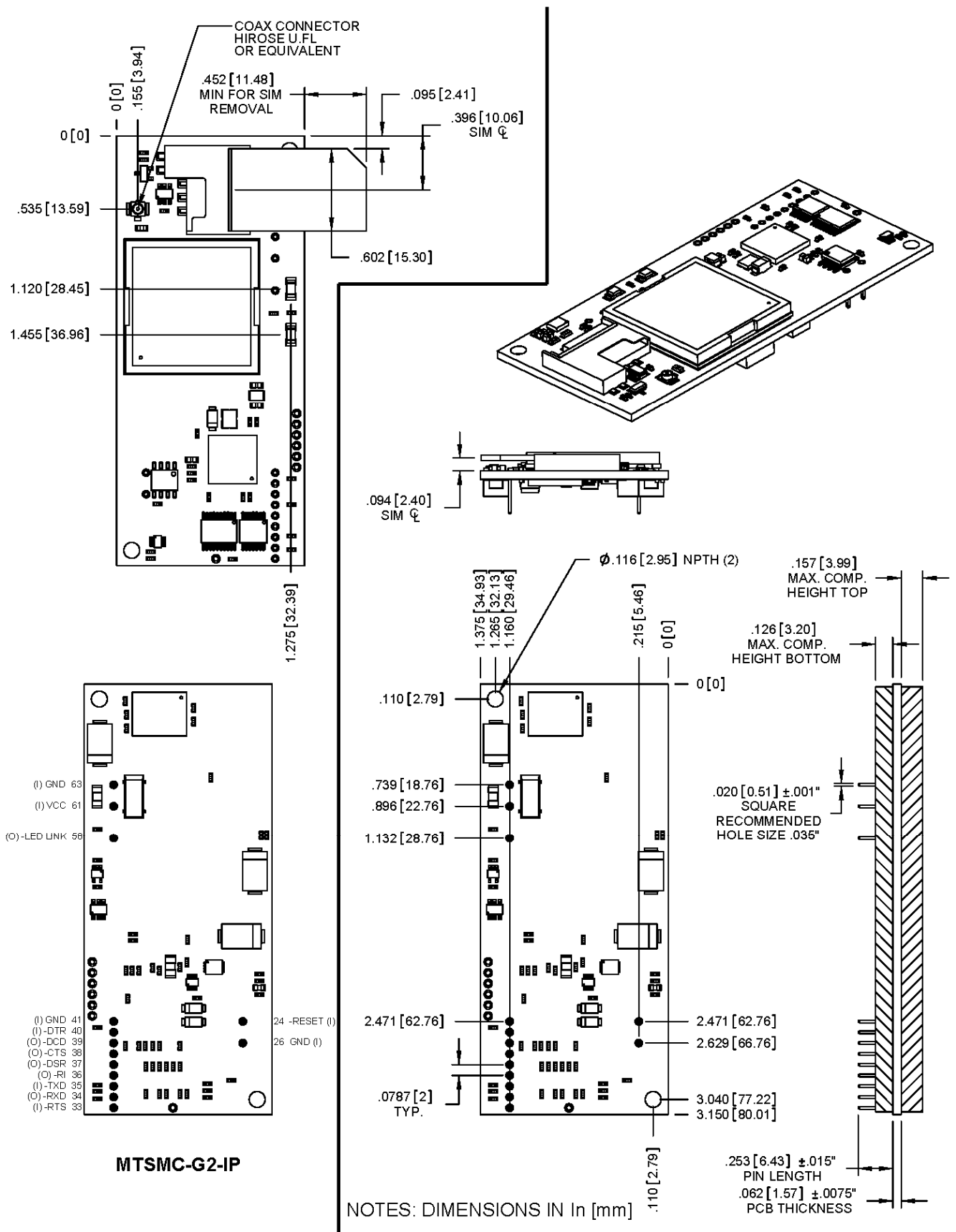

Mechanical Drawings – GPS Build

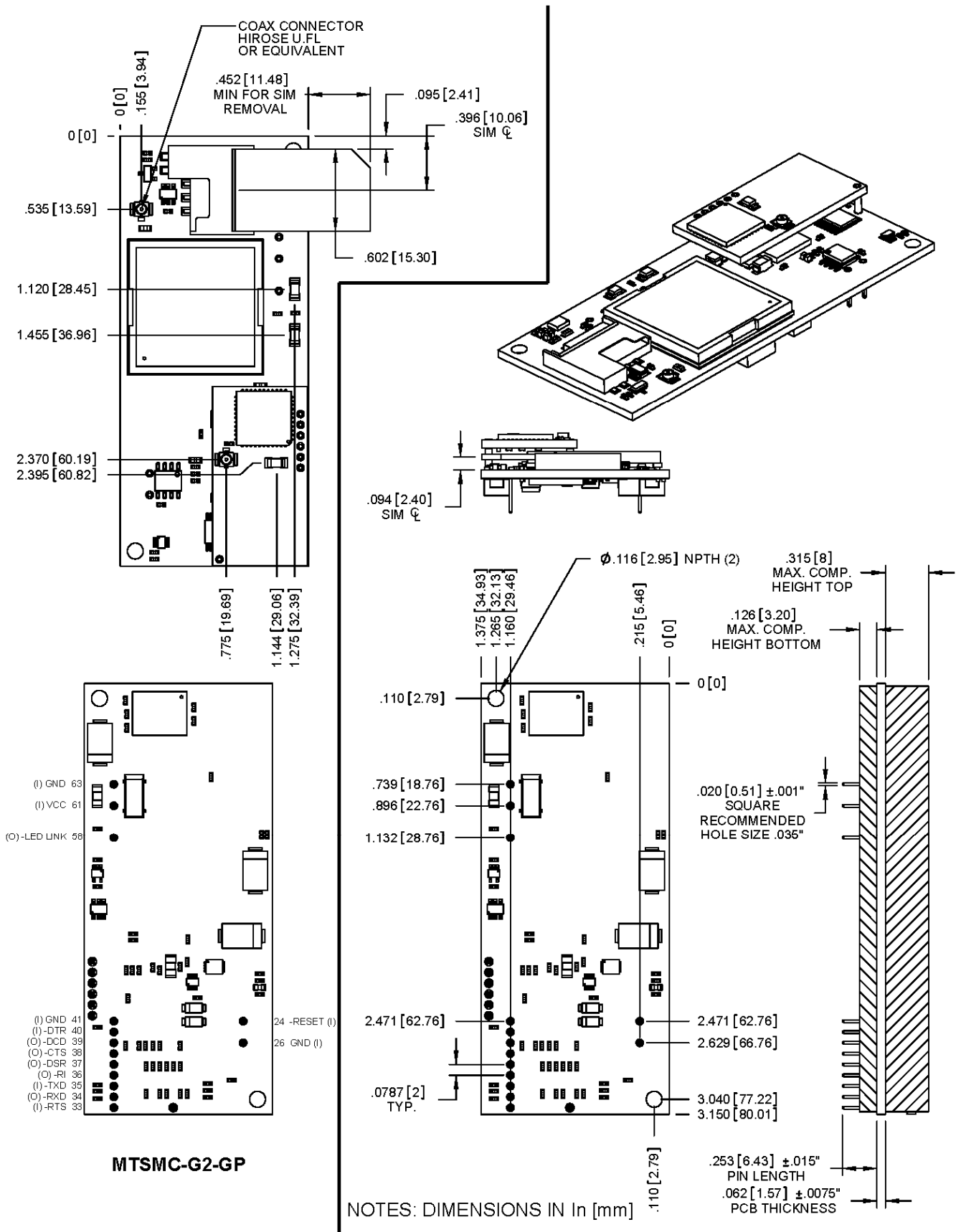

DC Electrical Characteristics

Units: Volts

5V DC Characteristics (VDD = 5V ± 0.25V) VDDMAX = 5.25V

Parameter	Minimum	Maximum
Digital Signal Input Low Level –DTR (40), –TXD (35), –RTS (33)	GND	0.8
Digital Signal Input High Level –DTR (40), –TXD (35), –RTS (33)	2	Vcc
Digital Signal Output Low Level –DCD (39), –CTS (38), –DSR (37), –RI (36), –RXD (34)		0.4
Digital Signal Output High Level –DCD (39), –CTS (38), –DSR (37), –RI (36), –RXD (34)	3.84	
Reset (Low Active) Input Low Level –Reset (24)		0.8
Reset (Low Active) Input High Level –Reset (24)	2	
Digital Input Capacitance	14pF	

Power Measurements

Basic and Voice Builds, MTSMC-G2 and MTSMC-G2-V, Measured Power at Input Voltage 5.00*

	Sleep Mode	Typical	Maximum	Peak
Current (AMPS)	0.049	0.113	0.24	1.10
Watts	0.245	0.564	1.195	

IP Build, MTSMC-G2-IP, Measured Power at Input Voltage 5.00*

	Sleep Mode	Typical	Maximum	Peak
Current (AMPS)	0.080	0.135	0.280	1.250
Watts	0.382	0.664	1.358	

Note: Current Peak = 1500mA maximum during Tx burst.

GP Build, MTSMC-G2-GP (for GPS,) Measured Power at Input Voltage 5.00*

	Sleep Mode	Typical	Maximum	Peak
Current (AMPS)	0.132	0.212	0.355	1.500
Watts	0.653	1.043	1.732	

* Multi-Tech Systems, Inc. recommends that the customer incorporate a 10% buffer into their power source when determining product load.

Application Notes

LED Interface

The LED signal is used to indicate the working status of the SocketModem.

LED 1 – Link Status – Available for G2, G2-V, G2-IP, and G2-GP Builds

LED 1 Signal	Link Status LED	
OFF	Download mode or switched OFF	
ON	Continuously lit	Switched ON (not registered on the network)
	Blinking	Switched ON (registered on the network)

LED 2 – Heartbeat LED – Available for G2-IP and G2-GP Builds

LED 2 Signal	Heartbeat LED
OFF	No power to the unit
Blinking	The unit is functioning

RF Performances

RF performances are compliant with the ETSI recommendation 05.05 and 11.10.

Note: The following statistics are subject to change due to pending test results.

The main parameters are:

Receiver Features

- EGSM Sensitivity : < -104 dBm
- GSM 1800/GSM 1900 Sensitivity : < -102 dBm
- Selectivity @ 200 kHz : > +9 dBc
- Selectivity @ 400 kHz : > +41 dBc
- Dynamic range : 62 dB
- Intermodulation : > -43 dBm
- Co-channel rejection : + 9 dBc

Transmitter Features

- Maximum output power (EGSM) : 33 dBm ± 2 dB
- Maximum output power (DCS/PCS) : 30 dBm ± 2 dB
- Minimum output power (EGSM): 5 dBm ± 5 dB
- Minimum output power (DCS/PCS): 0 dBm ± 5 dB
- H2 level : < -30 dBm
- H3 level : < -30 dBm
- Noise in 925 - 935 MHz : < -67 dBm
- Noise in 935 - 960 MHz : < -79 dBm
- Noise in 1805 - 1880 MHz : < -71 dBm
- Phase error at peak power : < 5 ° RMS
- Frequency error : ± 0.1 ppm max

RF Connection and Antenna

The RF connector on the SocketModem GPRS is a UFL standard type. See Chapter 1 for Antenna System details.

Microphone Inputs

Note: For Voice Build Only.

The MIC inputs are differential ones. They already include the convenient biasing for an electret microphone (0.5 mA and 2 Volts). This electret microphone can be directly connected on these inputs. The impedance of the microphone has to be around 2K. These inputs are the standard ones for a handset design.

The gain of the MIC inputs is internally adjusted. The gain can be tuned from 30dB to 51dB. The connection to the microphone is direct.

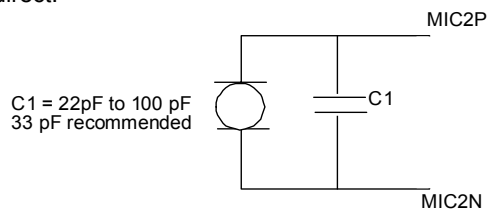

Changing the Quad Band

If for any reason, such as moving the modem from one geographical area to another, you want to change the band, you can accomplish this by using the **+WMBS** AT Command.

Steps for Changing the GSM Band

Use a terminal application such as HyperTerminal for entering the AT Command.

1. To open HyperTerminal, click **Start**. Then select **Programs > Accessories > Communications**. Then click **HyperTerminal**.
2. When the command window opens, type **AT+WMBS=<Band><Param>**. Press **Enter**.
 - For **<Band>**, enter the option you desire:
4 = Dual-band mode 850/1900MHz
5 = Dual-band mode 900/1800MHz
 - For **<Param>**, enter the option you desire:
0 = Modem must be reset in order to use the specified band(s). This is the default.
1 = Modem restarts immediately using the specified band(s).

Example: AT+WMBS=4,0. Press **Enter**.

Chapter 3 – SocketModem® Cell and SocketModem iCell CDMA 1xRTT (MTSMC-C1)

Introduction

SocketModem Cell – The Multi-Tech SocketModem Cell cellular modem is a complete, ready-to-integrate communications device that offers standards-based dual-band CDMA 1xRTT performance. This quick-to-market communications device allows developers to add cellular communication to products with a minimum of development time and expense. The SocketModem Cell cellular modem is based on industry-standard open interfaces and utilizes Multi-Tech's Universal Socket design.

SocketModem iCell – The Multi-Tech SocketModem iCell intelligent cellular modem is a complete, ready-to-integrate communications device that offers standards-based dual-band CDMA 1xRTT performance. This quick-to-market communications device allows developers to add cellular communication and GPS tracking to products with a minimum of development time and expense. The intelligence of the embedded Universal IP™ stack allows for automatic/persistent connectivity for mission critical applications and enhanced M2M functionality. The SocketModem iCell intelligent cellular modem is based on industry-standard open interfaces and utilizes Multi-Tech's Universal Socket design.

Notes about Activation:

- These units are shipped without network activation.
- To connect to the cellular network, you will have to establish a cellular account. See the Cellular Activation procedures in a separate document included with your Developer Kit and available on the Developer Kit CD.

Product Build Options and Ordering Information

Product	Description	Region	Order This Product ✓
BUILDS FOR SOCKETMODEMS USING SPRINT SERVICES			
MTSMC-C1-N2	SocketModem Cell 800/1900 MHz CDMA 1xRTT – Sprint – Data only	USA	
MTSMC-C1-V-N2	SocketModem Cell 800/1900 MHz CDMA 1xRTT – Sprint – Data/Voice	USA	
MTSMC-C1-GP-N2	SocketModem iCell 800/1900 MHz CDMA 1xRTT – Sprint – with GPS	USA	
MTSMC-C1-IP-N2	SocketModem iCell 800/1900 MHz CDMA 1xRTT – Sprint – with Universal IP	USA	
BUILDS FOR SOCKETMODEMS USING VERIZON WIRELESS SERVICES			
MTSMC-C1-N3	SocketModem Cell 800/1900 MHz CDMA 1xRTT – Verizon – Data Only	USA	
MTSMC-C1-V-N3	SocketModem Cell 800/1900 MHz CDMA 1xRTT – Verizon – Data/Voice	USA	
MTSMC-C1-GP-N3	SocketModem iCell 800/1900 MHz CDMA 1xRTT – Verizon – with GPS	USA	
MTSMC-C1-IP-N3	SocketModem iCell 800/1900 MHz CDMA 1xRTT – Verizon – with Universal IP	USA	
BUILDS FOR SOCKETMODEMS USING AERIS COMMUNICATION, INC. SERVICES			
MTSMC-C1-N16	SocketModem Cell 800/1900 MHz CDMA 1xRTT – Aeris – Data Only	USA	
MTSMC-C1-V-N16	SocketModem Cell 800/1900 MHz CDMA 1xRTT – Aeris – Data/Voice	USA	
MTSMC-C1-GP-N16	SocketModem iCell 800/1900 MHz CDMA 1xRTT – Aeris – with GPS	USA	
MTSMC-C1-IP-N16	SocketModem iCell 800/1900 MHz CDMA 1xRTT – Aeris – with Universal IP	USA	
Developer Kit			
MTSMI-UDK	Universal Developer Kit	Global	

How to Read the Product Codes in the Table Above:

C1	CDMA
V	Voice (Microphone and Speaker)
GP	Dedicated GPS Receiver
IP	Universal IP™ Stack
N2	Sprint (USA)
N3	Verizon Wireless
N16	Aeris Communications, Inc. (USA)
UDK	Universal Developer Kit

Other Product Codes:

The complete product code may end in **.Rx**. For example, MTSMC-C1-N3.Rx.
“R” indicates product revision. “x” is the revision number.

AT Commands Reference Guides

Products	AT Commands Reference Guide Title and Document Product Number	Fax Commands	Voice Commands
SocketModem Cell (MTSMC-C1, MTSMC-C1-V)	CDMA C1 AT Commands Reference Guide (S000478A)	NA	Included in S000478x – Voice commands apply to Voice builds only
SocketModem iCell (MTSMC-C1-IP, MTSMC-C1-GP)	CDMA C1 AT Commands Reference Guide (S000478A) Universal IP Commands (S000457x)	NA	NA

Technical Specifications

The SocketModem Cell and SocketModem iCell MTSMC-C1) meet the following specifications:

Category	Description
Standard	CDMA 1xRTT
Frequency Bands	Dual-band 800/1900 MHz CDMA
Serial/Data Speed	Serial interface supporting DTE speeds to 230K Packet data up to 153.6K bps forward and reverse Circuit-switched data up to 14.4K bps
Data Format	Asynchronous, transparent and non-transparent
Weight	1.2 oz. (34 g)
Dimensions	3.15" (80.010mm) x 1.375 (34.925mm)
Operating Temperature	-30° to +70° C
Storage Temperature	-40° to +85° C
Humidity	20% to 90% (non-condensing)
Operating Voltage	5VDC
Antenna Connector	Surface mount UFL (one for cellular and one for GPS)
IP Protocols Supported	MTSMC-C1, MTSMC-C1-V DNS Resolve, FTP client, LCP, PPP (dial-out), TCP socket, UDP socket, PAP & CHAP authentication MTSMC-C1-IP, MTSMC-C1-GP DNS Client, FTP Client, ICMP (Ping), POP3 Client, SMTP Client, TCP Client & Server, UDP Client & Server, IP, PPP (dial-out) with PAP & CHAP authentication
M2M Applications	MTSMC-C1-IP, MTSMC-C1-GP Automatic connect/reconnect, device monitor, modem emulation, Ping & TCP keep alive, wake-up on caller ID, wake-up on ring, GPS tracking (GP model only)
Compliance	EMC Compliance FCC Part 15 Class B, 22, 24 IC: RSS 129, 132, 133 EN 55022 Safety Compliance UL 60950-1 cUL 60950-1 IEC 60950-1 Network Compliance CDG 1 & 2
Warranty	2 years

Note: The radio's performance may be affected at the temperature extremes. This is considered normal. The radio is designed to automatically fallback in class and reduces transmitter power to avoid damage to the radio. There is no single cause for this function. Rather, it is the result of an interaction of several factors, such as the ambient temperature, the operating mode and the transmit power.

Important

MTSMC Tooling Holes and Mounting Hardware

It is recommended that nylon hardware be used if the SocketModems are to be mounted using the two tooling holes due to possible traces and vias around the tooling holes. #4 or M2/M3 hardware should be used for mounting.

This applies to the following cellular SocketModem® Cell and SocketModem iCell CDMA 1xRTT (MTSMC-C1)

Note: See the Mechanical Drawings for MTSMC-C1 on the following four pages.

Mechanical Drawings – Basic Build

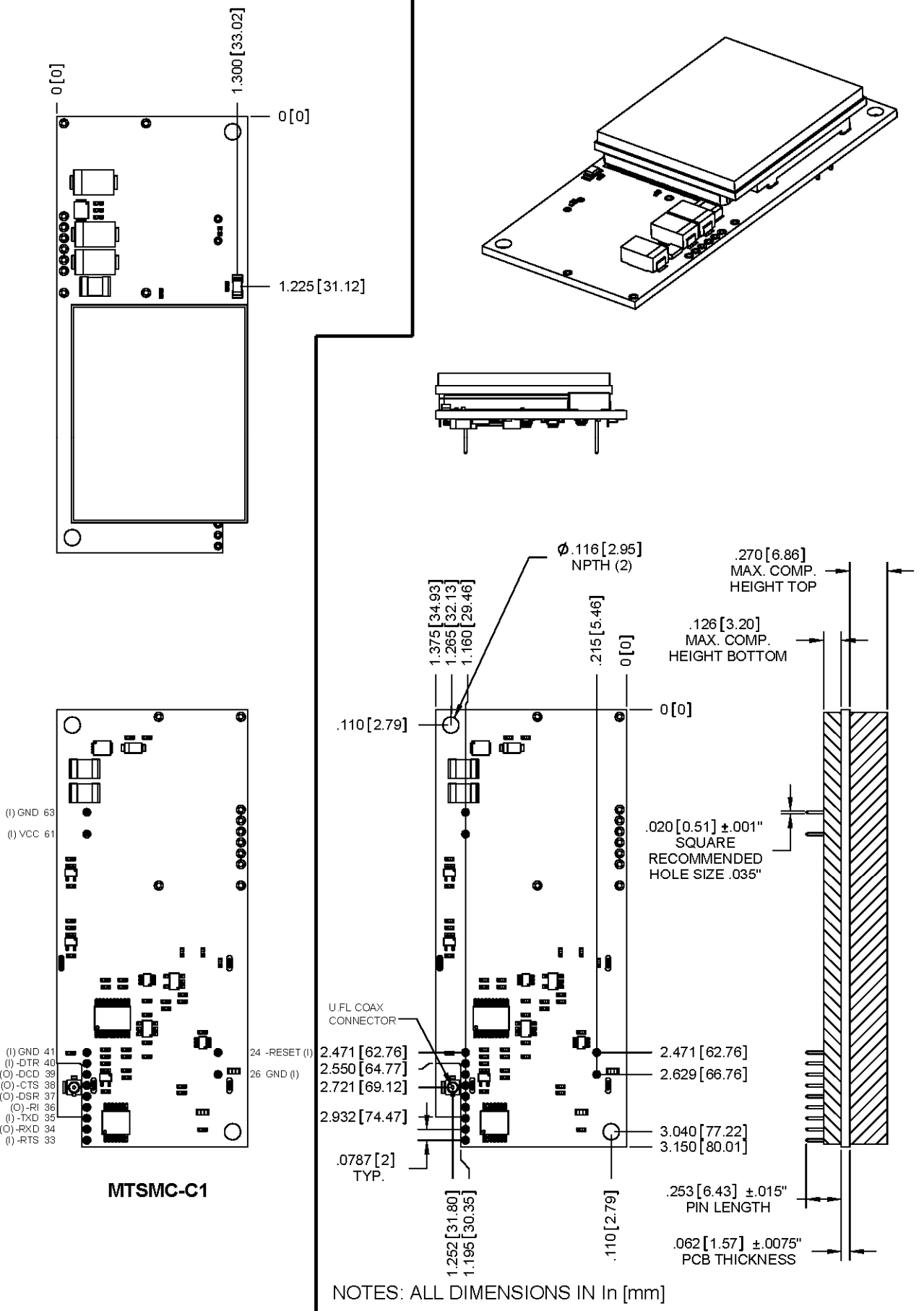

Mechanical Drawings – Voice Build

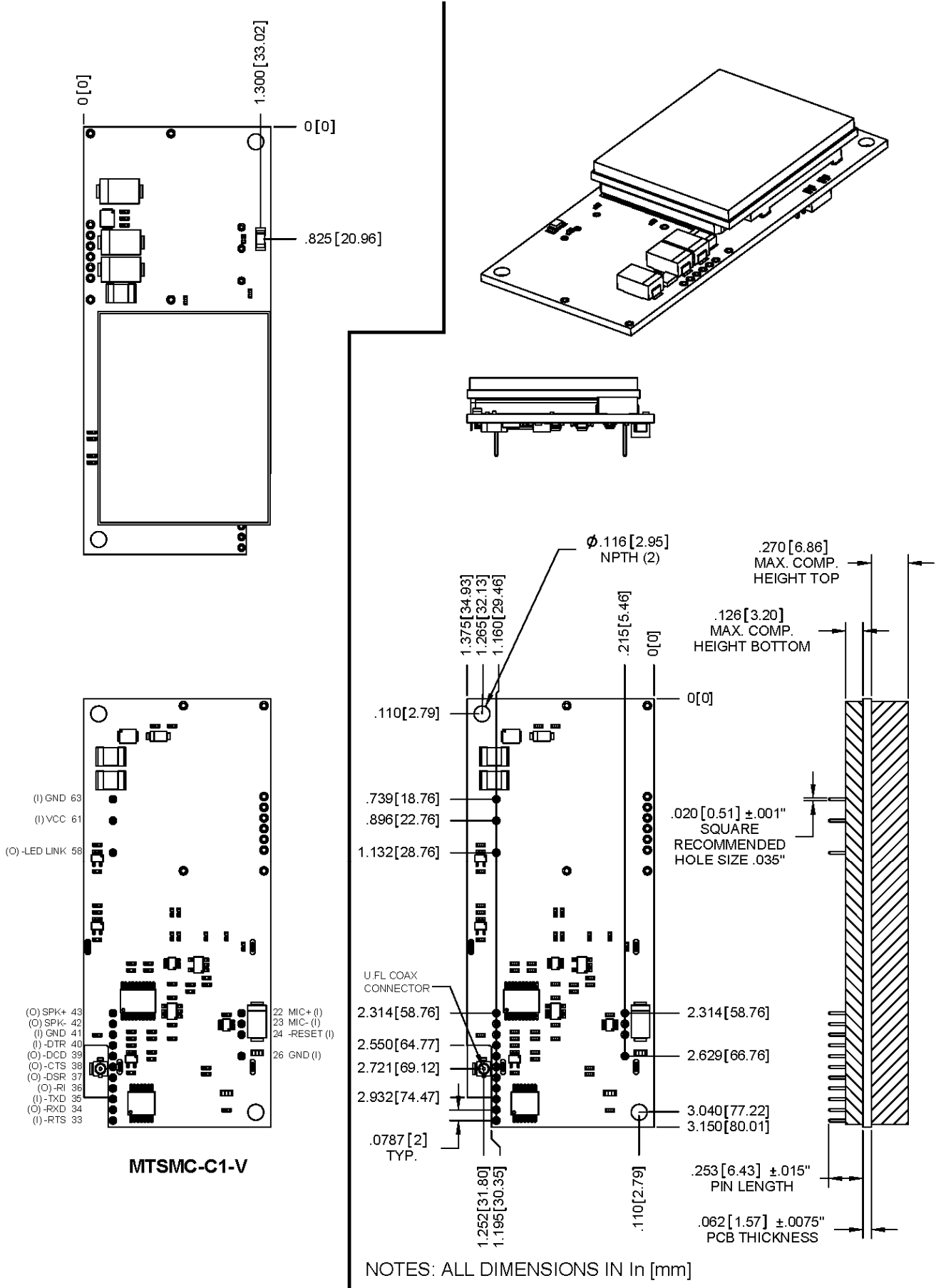

Mechanical Drawings – IP Build

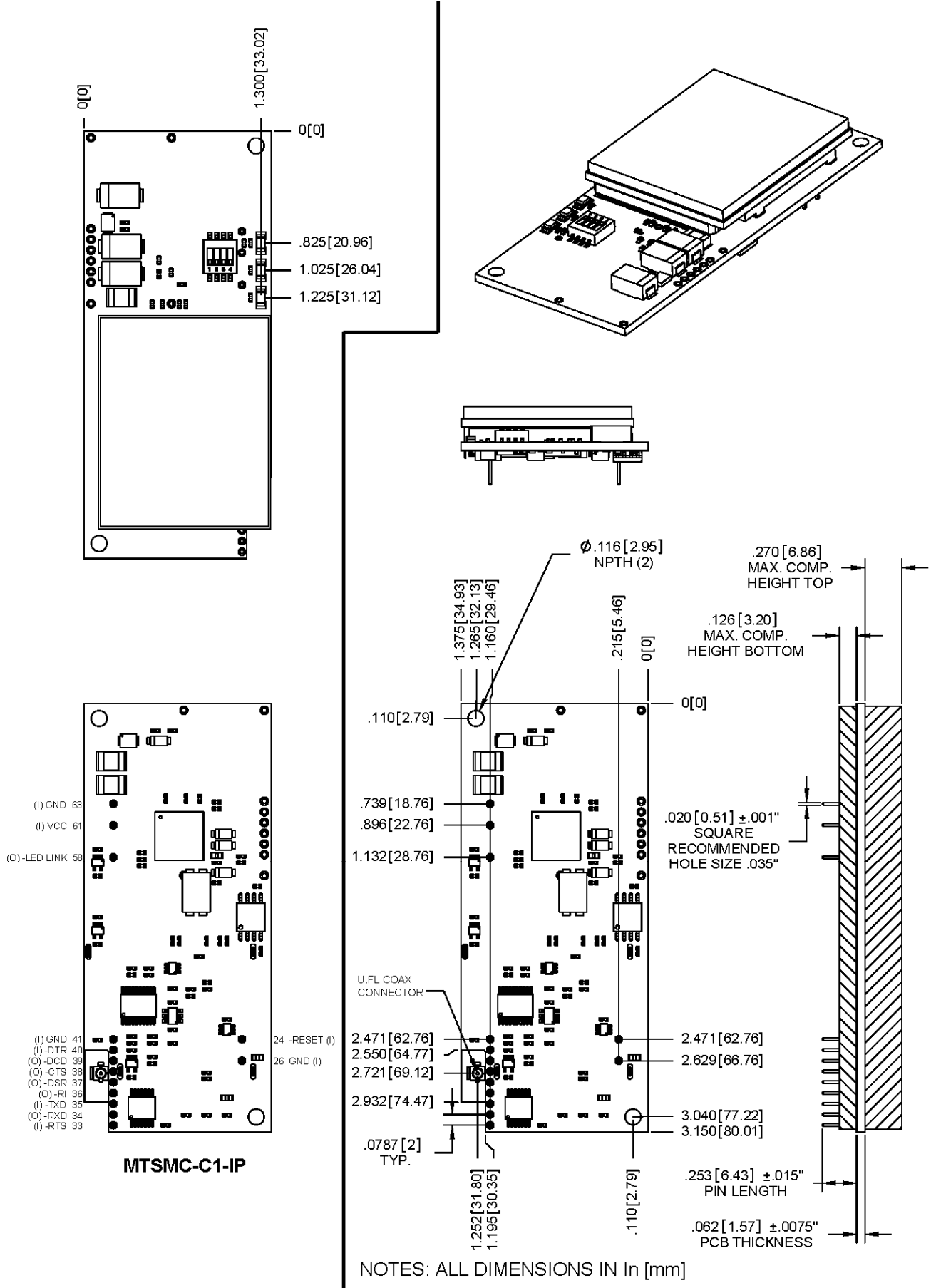

Mechanical Drawings – GPS Build

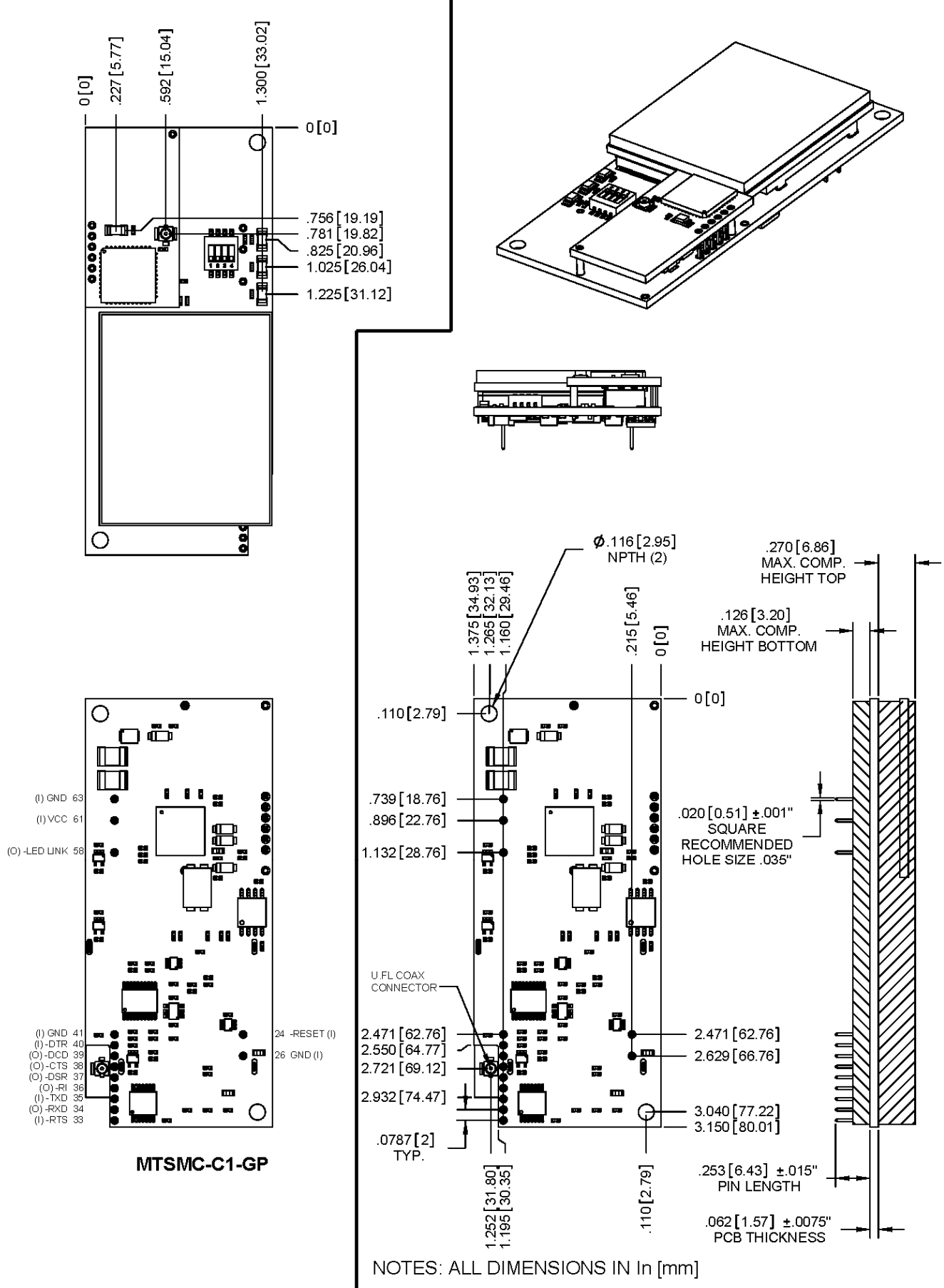

DC Electrical Characteristics

5VDC Characteristics (VDD = 5V ± 0.5V) VDDMAX = 5.5V			
Digital Inputs –DTR (40), –TXD (35), –RTS (33)	Input High Min 2.0V	Input Low Max 0.8V	
–RESET	Input High Min 2.0V	Input Low Max 0.8V	
Digital Outputs –DCD (39), –CTS (38), –DSR (37), –RI (36), –RXD (34)	Output High Min 3.8V	Output Low Max 0.55V	Current Drive: 4mA
Digital Input Capacitance			10 pF

Power Measurements

Basic Build and Voice Build (MTSMC-C1 and MTSMC-C1-V) Measured Power at Input Voltage 5.00*

Input Voltage = 5.0 Volts	Sleep Mode	Typical	Maximum
Current (AMPS)	0.010	0.150	0.585
Watts	0.050	0.747	2.884

IP Build (MTSMC-C1-IP) Measured Power at Input Voltage 5.00*

Input Voltage = 5.0 Volts	Sleep Mode	Typical	Maximum
Current (AMPS)	0.040	0.185	0.560
Watts	0.199	0.919	2.766

GPS Build (MTSMC-C1-GP) Measured Power at Input Voltage 5.00*

Input Voltage = 5.0 Volts	Sleep Mode	Typical	Maximum
Current (AMPS)	0.130	0.270	0.650
Watts	0.646	1.339	3.205

* Multi-Tech Systems, Inc. recommends that the customer incorporate a 10% buffer into their power source when determining product load.

Application Notes

LED Interface

The LED signal is used to indicate the working status of the SocketModem.

LED 1 – Link Status – Available for C1, C1-V, C1-IP, and C1-GP Builds

LED 1 Signal	Link Status LED	
OFF	The unit is in download mode or switched OFF	
ON	Continuously lit	Switched ON (not registered on the network)
	Blinking	Switched ON (registered on the network)

LED 2 – Heartbeat LED – Available for C1-IP and C1-GP Builds

LED 2 Signal	Heartbeat LED
OFF	No power to the unit or switched OFF
Blinking	The unit is functioning

LED 3 – Signal Strength LED – Available for C1-IP and C1-GP Builds

LED 3 Signal	Signal Strength LED
OFF	No signal
Blinking	The faster the LED blinks, the stronger the signal

RF Interface

Radio Characteristics

	CDMA 800	CDMA 1900
Frequency RX	869 to 894 MHz	1930 to 1990 MHz
Frequency TX	824 to 849 MHz	1850 to 1910 MHz
Impedance	50 ohms	
VSWR	<2	
Typical Radiated Gain	0 dBi in at least one direction	
Output Power	.35W in CDMA	

RF Connection and Antenna

The RF connector on the SocketModem is an UFL standard type. See Chapter 1 for Antenna System details.

Baud Rate Switches on the SocketModem iCell

Note: For the serial interface.

MTSMC-C1 SocketModem Baud Rate Dip Switch Settings

ON

				921600
•	•	•	•	
1	2	3	4	

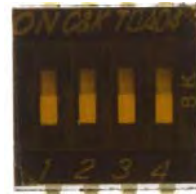

ON

•				460800
	•	•	•	
1	2	3	4	

ON

	•			230400
•		•	•	
1	2	3	4	

ON

•	•			115200
		•	•	
1	2	3	4	

ON

		•		57600
•	•		•	
1	2	3	4	

ON

•		•		38400
	•		•	
1	2	3	4	

ON

	•	•		19200
•			•	
1	2	3	4	

ON

•	•	•		9600
			•	
1	2	3	4	

ON

			•	+IPR/USB enable
•	•	•		
1	2	3	4	

ON

•	•	•	•	+IPR
1	2	3	4	

Default

Chapter 4 – SocketModem® EDGE (MTSMC-E1)

Introduction

The Multi-Tech SocketModem EDGE embedded cellular modem delivers some of the fastest cellular data speeds by utilizing EDGE technology. It allows users to connect to the Internet and send and receive data up to three times faster than possible with an ordinary GSM/GPRS network making it ideal for highly data-intensive applications. Based on industry-standard open interfaces, the SocketModem EDGE cellular modem is equipped with quad-band GSM, which means it can be used worldwide on all existing GSM networks.

Product Build Options and Ordering Information

Product	Description	Region	Order This Product ✓
MTSMC-E1	SocketModem Quad Band EDGE Class 12 – 5V	Global	
MTSMC-E1-V	SocketModem Quad Band EDGE Class 12 w/Voice – 5V	Global	
MTSMI-UDK	Universal Developer Kit	Global	

How to Read the Product Codes in the Table Above:

E1 EDGE
V Voice (Microphone and Speaker)
UDK Universal Developer Kit

Other Product Codes:

The complete product code may end in **.Rx**. For example, MTSMC-E1.Rx
“R” indicates product revision. “x” is the revision number.

AT Commands Reference Guide

Product	Reference Guides Title and Document Product Number	Fax Commands	Voice Commands
SocketModem EDGE (MTSMC-E and E1)	SocketModem EDGE AT Commands Reference Guide (S000371x)	NA	Included in S000371x

Technical Specifications

The SocketModem EDGE (MTSMC- E1) cellular modem meets the following specifications:

Category	Description
Standards	EDGE: E-GPRS Class 12 GPRS: GPRS Class 12
Data Speed	Packet Data rates up to 240K bps (modulation & coding scheme, MCS 1-9, Mobile station Class B) Circuit-switched data up to 14.4 kbps non-transparent mode, asynchronous
Serial Speed	Serial interface supporting DTE speeds to 460K bps
Band Frequency	Quad-band 850/900/1800/1900 MHz
Connectors	Antenna: MMCX SIM: Standard 1.8V or 3V SIM receptacle
IP Protocols Supported	TCP, UDP, DNS, FTP, SMTP, POP3, HTTP
Operating Voltage	5VDC
Operating Temperature	-30° to +70° C
Storage Environment	-40° to +85° C
Humidity	20% to 90% non-condensing
Physical Dimensions	2.541" L x 1.375" W 64.541mm L x 34.92 mm W For maximum component heights top and bottom, see the Mechanical Drawings on the next two pages.
Weight	1 oz. (0.028 kg.)
Compliance	EMC Compliance FCC Part 2, 15, 22, 24 EN 55022 EN 55024 Radio Compliance FCC Part 22 FCC Part 24 RSS 132 RSS 133 EN 301 511 EN 301 489-1 EN 301 489-7 AS/ACIF S042.1 AS/ACIF S042.3 Safety Compliance UL 60950-1 cUL 60950-1 IEC 60950-1 AS/NZS 60950:2000 Network Compliance PTCRB
Warranty	2 years

Note: The radio's performance may be affected at the temperature extremes. This is considered normal. The radio is designed to automatically fallback in class and reduces transmitter power to avoid damage to the radio. There is no single cause for this function. Rather, it is the result of an interaction of several factors, such as the ambient temperature, the operating mode and the transmit power.

Mechanical Drawings – Basic Build

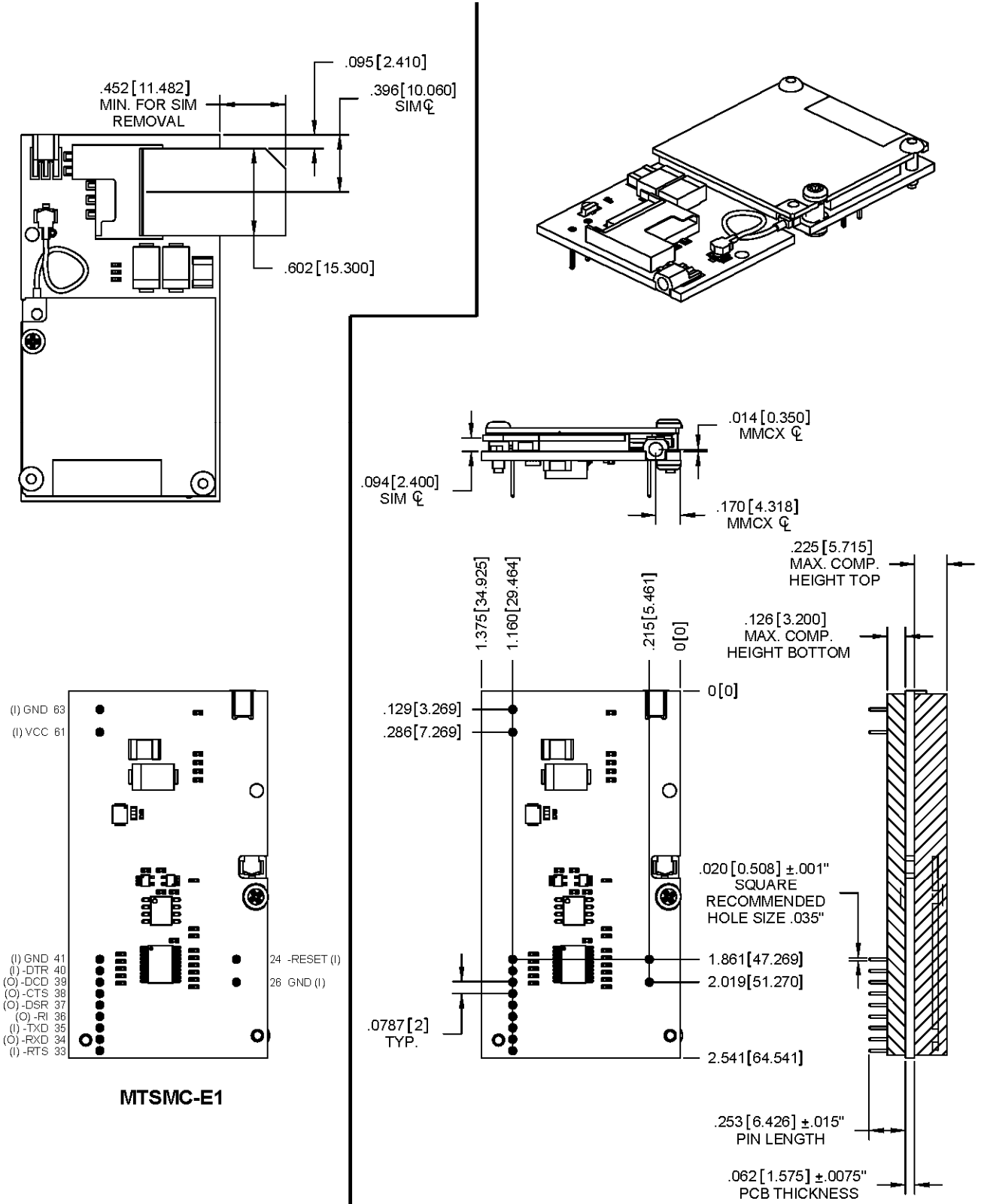

NOTES: DIMENSIONS IN In [mm]

Mechanical Drawings – Voice Build

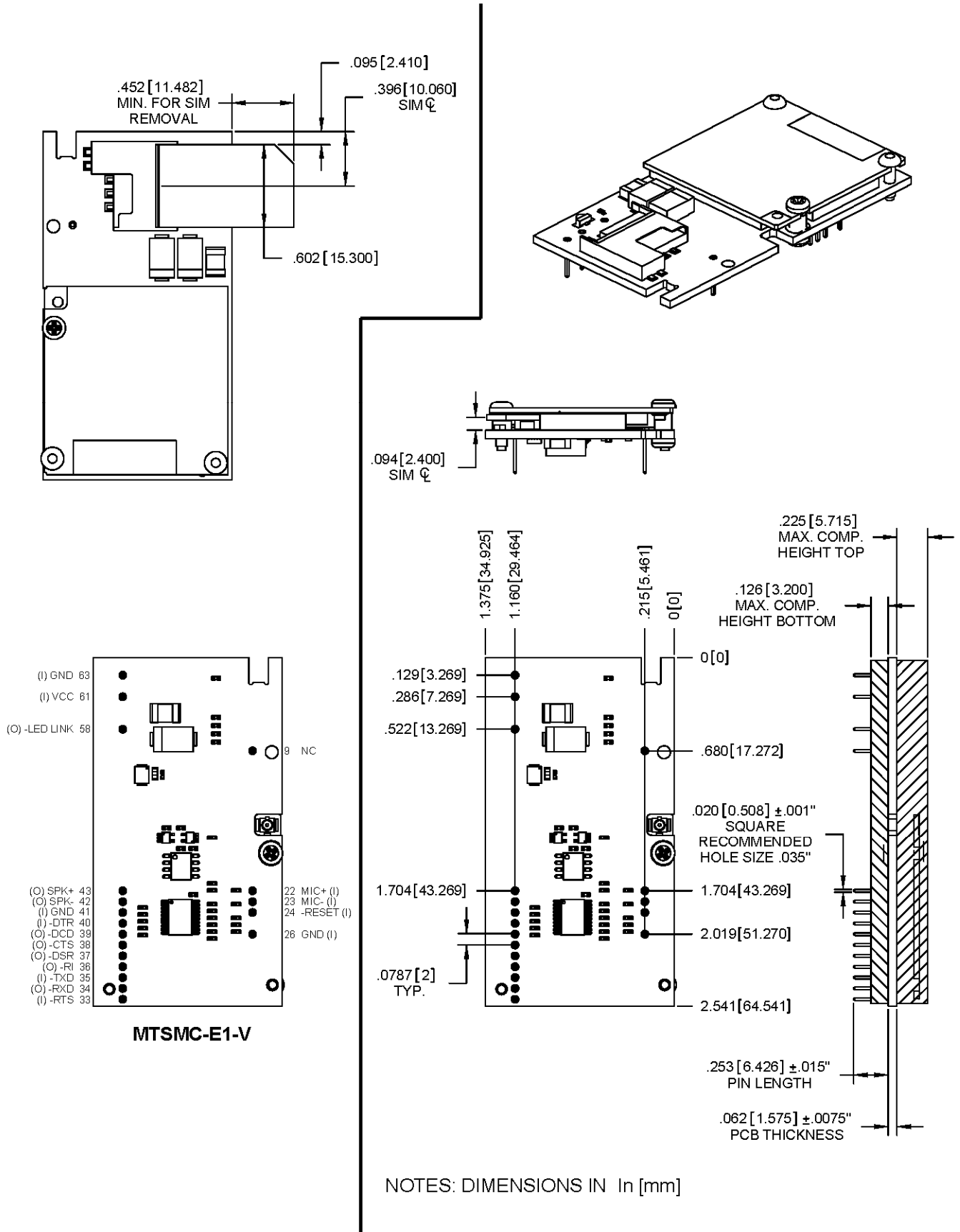

DC Electrical Characteristics

Operating Conditions

5 Volts

Parameter	Minimum	Maximum
Supply Range - Vcc	4.75	5.25

Absolute Maximum Rating

Parameter	Minimum	Maximum
Voltage at Any Signal Pin	0	5

DC Electrical Characteristics

Parameter	Units (Volts)	
	Minimum	Maximum
Digital Signal Input Low Level	0	0.8
Digital Signal Input High Level	2	5
Digital Signal Output Low Level	0	0.33
Digital Signal Output High Level	3.84	5
Reset (Low Active) Input Low	0	1.14
Reset (Low Active) Input High	2.7	5
Digital Input Capacitance	10pF	

Power Measurements

MTSMC-E1 and MTSMC-E1-V Measured Power* at Input Voltage 5.00

	Sleep Mode	Typical	Maximum	Peak
Current (AMPS)	0.010	0.128	0.675	1.500
Watts	0.050	0.64	3.2	

* Multi-Tech Systems, Inc. recommends that the customer incorporate a 10% buffer into their power source when determining product load.

Application Notes

RF Performances

RF performances are compliant with the ETSI recommendation 05.05 and 11.10. The main parameters are:

Receiver Features

- EGSM Sensitivity : < -108 dBm
- GSM 1800/GSM 1900 Sensitivity : < -107 dBm
- Selectivity @ 200 kHz : > +9 dBc
- Selectivity @ 400 kHz : > +41 dBc
- Dynamic range : 62 dB
- Intermodulation : > -43 dBm
- Co-channel rejection : + 9 dBc

Transmitter Features

- Maximum output power (EGSM) : 24 dBm +/- 2 dB
- Maximum output power (DCS/PCS) : 30 dBm +/- 2 dB
- Minimum output power (EGSM): 5 dBm +/- 5 dB
- Minimum output power (DCS/PCS): 0 dBm +/- 5 dB
- H2 level : < -30 dBm
- H3 level : < -30 dBm
- Noise in 925 - 935 MHz : < -67 dBm
- Noise in 935 - 960 MHz : < -79 dBm
- Noise in 1805 - 1880 MHz : < -71 dBm
- Phase error at peak power : < 5 ° RMS
- Frequency error : +/- 0.1 ppm max

RF Connection and Antenna

The RF connector on the SocketModem is an MMCX standard type. See Chapter 1 for Antenna System details.

Audio Interface – Electrical Characteristics

Speaker Output

Differential speaker output capable of driving 8 ohm load. 1.0945 Vpp (differential) typical.

Microphone Input

Balanced microphone input: full scale input 1.1 Vpp.

Microphone Inputs

The MIC inputs are differential ones. They already include the convenient biasing for an electret microphone (0,5 mA and 2 Volts). This electret microphone can be directly connected on these inputs. The impedance of the microphone has to be around 2K. These inputs are the standard ones for a handset design.

The gain of the MIC inputs is internally adjusted. The gain can be tuned from 30dB to 51dB. The connection to the microphone is direct.

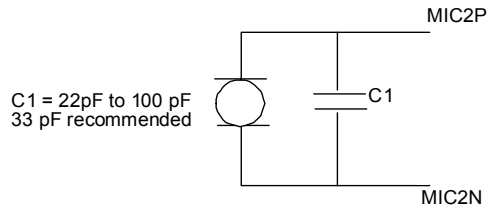

Chapter 5 – SocketModem® iCell – HSPA (MTSMC-H4)

Introduction

The Multi-Tech SocketModem iCell HSPA embedded cellular modem delivers some of the fastest cellular data speeds by utilizing HSPA technology. These modems allow users to connect to the Internet and send and receive data faster than possible with an ordinary GSM/GPRS network making it ideal for highly data-intensive applications. Based on industry-standard open interfaces, the SocketModem cellular modem is equipped with quad-band, high-speed RS232 technology, which means it can be used worldwide on all existing GSM networks. In addition, it utilizes Multi-Tech's universal socket design. This SocketModem is for use on GSM/HSPA networks.

Product Build Options and Ordering Information

Product	Description	Region	Order This Product ✓
MTSMC-H4-IP	SocketModem® iCell – HSPA 7.2 Down / 5.76 Up – 850/900/1900/2100 Universal IP – Serial	Regional	
MTSMC-H4-GP	SocketModem® iCell – HSPA 7.2 Down / 5.76 Up – 850/900/1900/2100 GPS / Universal IP – Serial	Regional	
MTSMC-H4-MI-IP	SocketModem® iCell – HSPA 7.2 Down / 5.76 Up – 850/900/1900/2100 Universal IP – USB + Serial + GPIO	Regional	
MTSMC-H4-MI-GP	SocketModem® iCell – HSPA 7.2 Down / 5.76 Up – 850/900/1900/2100 GPS / Universal IP – USB + Serial + GPIO	Regional	
MTSMI-UDK	Universal Developer Kit	Global	

How to Read the Product Codes in the Table Above:

H4	HSPA (High-Speed Uplink and Downlink Packet Access)
IP	Universal IP™ Stack
GP	Dedicated GPS Receiver
MI	Multiple Interface
UDK	Universal Developer Kit

Other Product Codes:

The complete product code may end in **.Rx**. For example, MTSMC-H4-IP.Rx.
“R” indicates product revision. “x” is the revision number.

AT Commands Reference Guide

For Product	Reference Guides Title and Document Product Number	Fax Commands	Voice Commands
SocketModem Cell HSPA (MTSMC-H4)	SocketModem Cell and iCell HSPA AT Commands Reference Guide (S000483x)	NA	NA
SocketModem iCell HSPA (MTSMC-H4-IP and GP)	SocketModem Cell and iCell HSPA AT Commands Reference Guide (S000483x) and Universal IP Commands (S000457x)	NA	NA

Technical Specifications

The SocketModem Cell and iCell HSPA (MTSMC- H4) cellular modems meet the following specifications:

Category	Description
Standards	High Speed Packet Access (HSPA) GPRS CS1-CS4 (GPRS is General Packet Radio Service) EDGE MCS1-MCS9 (EDGE is Enhanced Data Rates for Global Evolution) Circuit-Switched (CS) domain data service based on UMTS and GSM (UMTS is Universal Mobile Telecommunications System and GSM is Global System for Mobile Communications) SMS is based on CS/Packet-Switched (PS) domain of GSM and WCDMA USB Interface is CDC-ACM compliant (Models with native USB support are not CDC-ACM compliant)
Data Speeds	HSDPA data service of up to 7.2 Mbps HSUPA data service of up to 5.76 Mbps UMTS PS domain data service of up to 384 kbps EDGE packet data service of up to 236.8 kbps GPRS packet data service of up to 85.6 kbps
Frequency Bands	GSM/GPRS/EDGE Quad-band: 850/900/1800/1900 HSUPA / HSDPA / UMTS Triple-band: 2100/1900/850 MHz with Rx diversity
Operating Voltage	5VDC \pm 10%
Dimensions	3.15" x 1.375" (80.010 mm x 34.925 mm)
Weight	1.0 oz (28 g)
SMS	Point-to-Point messaging Mobile-Terminated SMS Mobile-Originated SMS
USB Interface	USB 2.0 full speed (12Mbit/s) on MI builds only
Serial Modem Interface	Up to 921.6 Kbps
Ports	4 GPIO ports – MI builds only
Connectors	Antennas: All models have surface mount UFL antenna connectors. Standard and Rx diversity antennas are also supported. GPS models support an additional UFL antenna. SIM: Standard 1.8 / 3V SIM receptacle
Operating Temperatures	-30° C to +75° C
Storage Environment	-40° to +85° C
Humidity	20% to 90% non-condensing
Compliance	EMC Compliance FCC Part 15 Class B EN 55022 Class B EN 55024 Radio Compliance FCC Part 22 FCC Part 24 RSS 132 RSS 133 EN 301 511 EN 301 489-1 EN 301 489-3 (GPS model only) EN 301 489-7 EN 301 489-24 AS/ACIF S042.1 AS/ACIF S042.3 Safety Compliance UL 60950-1 cUL 60950-1 IEC 60950-1 AS/NZS 60950:2000 Network Compliance PTCRB
Warranty	2 years

Note: The radio's performance may be affected at the temperature extremes. This is considered normal. The radio is designed to automatically fallback in class and reduces transmitter power to avoid damage to the radio. There is no single cause for this function. Rather, it is the result of an interaction of several factors, such as the ambient temperature, the operating mode and the transmit power.

Important**MTSMC Tooling Holes and Mounting Hardware**

It is recommended that **nylon** hardware be used if the SocketModems are to be mounted using the two tooling holes due to possible traces and vias around the tooling holes. #4 or M2/M3 hardware should be used for mounting.

This applies to the SocketModem® Cell & SocketModem® iCell HSPA (MTSMC-H4)

Note: See the Mechanical Drawings for MTSMC-H4 on the following three pages.

Mechanical Drawings – Basic and IP Builds

Mechanical Drawings – USB Build

Mechanical Drawings – GPS Build

DC Electrical Characteristics

I/O DC Characteristics

5VDC Characteristics VDD = 5V (± 0.5V)

Digital Inputs –DTR (40), –TXD (35), –RTS (33)	Input High Min 2.0V	Input Low Max 0.8V	
–RESET	Input High Min 2.0V	Input Low Max 0.8V	
Digital Outputs –DCD (39), –CTS (38), –DSR (37), –RI (36), –RXD (34)	Output High Min 3.8V	Output Low Max 0.55V	Current Drive 4mA
Digital Input Capacitance			10 pF

Electrical Specifications

Pin	Signal Name	V _{IL}		V _{IH}		V _{OL}		V _{OH}	
		Min	Max	Min	Max	Min	Max	Min	Max
J18	SPI SPCK	--	--	--	--		0.3	2.9	
J19	SPI MISO	-0.3	0.7	2.0	5.5	--	--	--	--
J20	SPI MOSI	--	--	--	--		0.3	2.9	
J21	SPI CS	--	--	--	--		0.3	2.9	
J24	–RESET		0.8	2.0		--	--	--	--
J25	USB VBUS	-0.3	0.8	2.0	8.7	--	--	--	--
J26	GND	--	--	--	--	--	--	--	--
J27	USB DP		0.8	2			0.3	2.8	
J28	USB DM		0.8	2			0.3	2.8	
J33	–RTS	-0.3	0.8	2.0	5.5	--	--	--	--
J34	–RXD	--	--	--	--		0.26	3.98	
J35	–TXD	-0.3	0.8	2.0	5.5	--	--	--	--
J36	–RI	--	--	--	--		0.55	3.8	
J37	–DSR	--	--	--	--		0.26	3.98	
J38	–CTS	--	--	--	--		0.26	3.98	
J39	–DCD	--	--	--	--		0.26	3.98	
J40	–DTR	-0.3	0.8	2.0	5.5	--	--	--	--
J41	GND	--	--	--	--	--	--	--	--
J48	GPIO0	-0.3	0.8	2.0	5.5		0.4	2.9	
J49	GPIO1	-0.3	0.8	2.0	5.5		0.4	2.9	
J50	GPIO2	-0.3	0.8	2.0	5.5		0.4	2.9	
J51	GPIO3	-0.3	0.8	2.0	5.5		0.4	2.9	
J55	HEARTBEAT	--	--	--	--		0.4	2.9	
J58	–LED LINK	--	--	--	--	0	0.45	2.85	3.3
J61	VCC	--	--	--	--	--	--	--	--
J63	GND	--	--	--	--	--	--	--	--

Absolute Maximum Rating:

VCC Voltage (Survival) -0.3V to +5.5V

Pin-Out Specifications

Pin	Signal Name	Logic Level Voltage*	I/O	Description
J18	SPI SPCK	3.3	O	SPI clock signal
J19	SPI MISO	3.3	I	SPI master-in/slave-out
J20	SPI MOSI	3.3	O	SPI master-out/slave-in
J21	SPI CS	3.3	O	SPI chip select
J24	-RESET	3.3 – 5.0	I	Device reset (active low)
J25	USB VBUS	3.3 – 5.0	I	USB power supply input
J26	GND	GND	GND	Ground
J27	USB DP	3.3	I/O	USB data
J28	USB DM	3.3	I/O	USB data
J33	-RTS	5.0	I	Request to send (active low)
J34	-RXD	5.0	O	Received data (active low)
J35	-TXD	5.0	I	Transmitted data (active low)
J36	-RI	5.0	O	Ring indicator (active low)
J37	-DSR	5.0	O	Data set ready (active low)
J38	-CTS	5.0	O	Clear to send (active low)
J39	-DCD	5.0	O	Data carrier detect (active low)
J40	-DTR	5.0	I	Data terminal ready (active low)
J41	GND	GND	GND	Ground
J48	GPIO0	3.3	I/O	User configurable general purpose I/O
J49	GPIO1	3.3	I/O	User configurable general purpose I/O
J50	GPIO2	3.3	I/O	User configurable general purpose I/O
J51	GPIO3	3.3	I/O	User configurable general purpose I/O
J55	HEARTBEAT	3.3	O	Heartbeat from processor
J58	-LED LINK	3.3	O	Link status (active low, can sink up to 150mA)
J61	VCC	5.0	PWR	DC input power
J63	GND	GND	GND	Ground

*Note: A hyphen (-) indicates a range of acceptable logic levels.

Serial Model Pin Out

For Products: MTSMC-H4-IP, MTSMC-H4-GP

Pins Available With Current PCB: 24, 26, 33-41, 61, 63

USB + Serial + GPIO + GPS Data Pin Out

For Products: MTSMC-H4-MI-IP, MTSMC-H4-MI-GP

Pins Available With Current PCB: 24-28, 33-41, 48-51, 58, 61, 63

Pins to Be Added to the Next PCB Revision: 16-17, 22-28, 33-43, 48-51, 58, 61, 63, new GPS data pin

Design Consideration – Very Important Note

The current revision of the PCB will not accommodate the following pins:
22-23, 42-43 and the new GPS data pins 16-17.

While these pins are not present at this time, they will be present on the next hardware release.

You, as the developer, **must** take these new pins into account in your product design even if you have no plans for using them.

Power Measurements

Power* Draw for the MTSMC-H4-IP and MTSMC-H4-MI-IP

Input Voltage = 5.0 Volts	Sleep Mode	Typical	Maximum	Peak
GSM850				
Current (AMPS)	0.202	0.295	0.665	1.750
Watts	1.00	1.46	3.25	
HSDPA				
Current (AMPS)	0.205	0.685	1.035	
Watts	1.01	3.33	4.98	

Power* Draw for the MTSMC-H4-GP and MTSMC-H4-MI-GP:

Input Voltage= 5.0Volts	Sleep Mode	Typical	Maximum	Peak
GSM850				
Current (AMPS)	0.202	0.310	0.685	1.750
Watts	1.00	1.53	3.33	
HSDPA				
Current (AMPS)	0.205	0.650	0.995	
Watts	1.01	3.16	4.79	

* Multi-Tech Systems, Inc. recommends that the customer incorporate a 10% buffer into their power source when determining product load.

Application Notes

LED Interface

The LED signal is used to indicate the working status of the SocketModem.

LED 1 – Heartbeat LED – Available for -IP and -GP Builds

LED 1 Signal	Heartbeat LED
OFF	No power to the unit
Blinking	Power on

LED 2 – Link Status – Available for All Builds

LED 2 Signal	Link Status LED
OFF	No power to the unit
Continuously Lit	Powered and connected, but not transmitting or receiving
Slow Blink (~0.2 Hz)	Powered and searching for a connection
Faster Blink (~3 Hz)	Transmitting or receiving

LED 3 – Signal Strength – Available for -IP and -GP Builds

LED 3 Signal	Signal Strength LED
OFF	No signal
Blinking	The faster the LED blinks, the stronger the signal. The range for the blink rate is from ~0.5Hz to ~10Hz.

LED 4 – GPS Status – Available for -GP Build

LED 4 Signal	GPS Status LED
OFF	No power to the unit
Continuously Lit	Satellite not acquired
Blinking	Satellite acquired

RF Performances

RF performances are compliant with the ETSI recommendation 05.05 and 11.10.

The main parameters are:

Receiver Features

- EGSM Sensitivity: < -108 dBm
- GSM 1800/GSM 1900 Sensitivity: < -107 dBm
- Selectivity @ 200 kHz: > +9 dBc
- Selectivity @ 400 kHz: > +41 dBc
- Dynamic range: 62 dB
- Intermodulation: > -43 dBm
- Co-channel rejection: + 9 dBc

Transmitter Features

- Maximum output power (EGSM): 24 dBm \pm 2 dB
- Maximum output power (DCS/PCS): 30 dBm \pm 2 dB
- Minimum output power (EGSM): 5 dBm \pm 5 dB
- Minimum output power (DCS/PCS): 0 dBm \pm 5 dB
- H2 level: < -30 dBm
- H3 level: < -30 dBm
- Noise in 925 - 935 MHz: < -67 dBm
- Noise in 935 - 960 MHz: < -79 dBm
- Noise in 1805 - 1880 MHz: < -71 dBm
- Phase error at peak power: < 5 ° RMS
- Frequency error: \pm 0.1 ppm max

Frequency Bands Supported

WCDMA Frequency Band Support

Band	Frequencies
Band I WCDMA 2100	Tx: 1920 – 1980 MHz Rx: 2110 – 2170 MHz
Band II WCDMA 1900	Tx: 1850 – 1910 MHz Rx: 1930 – 1990 MHz
Band V WCDMA 850	Tx: 824 – 849 MHz Rx: 869 – 894 MHz
Band VI WCDMA 800	Tx: 830 – 840 MHz Rx: 875 – 885 MHz

GSM Frequency Band Support

Band	Frequencies
GSM 850	Tx: 824 – 849 MHz Rx: 869 – 894 MHz
EGSM 900	Tx: 800 – 915 MHz Rx: 925 – 960 MHz
GSM 1800	Tx: 1700 – 1785 MHz Rx: 1805 – 1880 MHz
GSM 1900	Tx: 1850 – 1910 MHz Rx: 1930 – 1990 MHz

GPS Frequency Band Support (for GPS model only)

Band	Frequency
GPS	1575.42 MHz

RF Connection and Antenna

The RF connector on the SocketModem is a UFL standard type. See Chapter 1 for Antenna System details.

Configuring the HSPA Modem on Linux SLAX 6

All recent distributions of Linux Kernel v2.6 or higher and CDC_ACM USB will work well with the HSPDA modem. Follow procedure outlined here using the HSDPA on Linux SLAX 6, an efficient live distribution you can install on a USB stick. See www.slax.org.

1. Set the HSDPA in modem mode so that it can be enumerated automatically:
AT^SUSB="Startup","Mdm"
AT^SMSO
2. Boot SLAX
3. Plug the USB cable into the PC
4. Enable enumeration in a terminal:
modprobe usbserial vendor=0x0681 product=0x0047
5. Make sure that the modem was enumerated
ls -la /dev/ttyUSB*
The response should be: /dev/ttyUSB0
6. Launch KPPP&
7. Create a new account with AT&T:
Dial *99***1#
8. Create a new modem
HC25
Modem device: /dev/ttyUSB0
Flow control: None
Line Termination: CR
Connection Speed: 921600
9. Add modem commands to the initialization string; i.e., ATZ and AT+CGDCONT=1,"IP","isp.cingular"
10. Enter PAP authentication
Login and enter password as usual

Baud Rate Switches on the SocketModem iCell

Note: For the serial interface.

ON

				921600
•	•	•	•	
1	2	3	4	

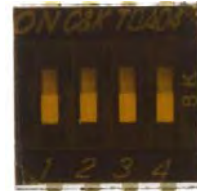

ON

				460800
•				
1	2	3	4	

ON

	•			230400
•		•	•	
1	2	3	4	

ON

•	•			115200
		•	•	
1	2	3	4	

ON

		•		57600
•	•		•	
1	2	3	4	

ON

•		•		38400
	•		•	
1	2	3	4	

ON

	•	•		19200
•			•	
1	2	3	4	

ON

•	•	•		9600
			•	
1	2	3	4	

ON

			•	+IPR/USB enable
•	•	•		
1	2	3	4	

ON

•	•	•	•	+IPR
1	2	3	4	

Default

Chapter 6 – SocketModem iCell – EV-DO (MTSMC-EV2)

Introduction

The Multi-Tech SocketModem iCell – EV-DO embedded cellular modems are 3G modules supporting CDMA EV-DO Rev A and below. Based on industry-standard open interfaces, the SocketModem cellular modems are equipped with dual-band 800/1900 MHz bands with receive diversity support on both bands. In addition, these SocketModems utilize Multi-Tech's universal socket design. This SocketModem is for use on CDMA networks.

Product Build Options and Ordering Information

Product	Description	Region	Order this Product ✓
MTSMC-EV2-IP-N2	SocketModem® iCell – EV-DO Rev. A Universal IP – Sprint – Serial	USA	
MTSMC-EV2-GP-N2	SocketModem® iCell – EV-DO Rev. A GPS/ Universal IP – Sprint – Serial	USA	
MTSMC-EV2-MI-IP-N2	SocketModem® iCell – EV-DO Rev. A Universal IP – Sprint – USB+Serial+GPIO	USA	
MTSMC-EV2-MI-GP-N2	SocketModem® iCell – EV-DO Rev. A GPS/ Universal IP – Sprint – USB+Serial+GPIO	USA	
MTSMC-EV2-IP-N3	SocketModem® iCell – EV-DO Rev. A Universal IP – Verizon Wireless – Serial	USA	
MTSMC-EV2-GP-N3	SocketModem® iCell – EV-DO Rev. A GPS/ Universal IP – Verizon Wireless – Serial	USA	
MTSMC-EV2-MI-IP-N3	SocketModem® iCell – EV-DO Rev. A Universal IP – Verizon Wireless – USB+Serial+GPIO	USA	
MTSMC-EV2-MI-GP-N3	SocketModem® iCell – EV-DO Rev. A GPS/ Universal IP – Verizon Wireless – USB+Serial+GPIO	USA	
MTSMC-EV2-IP-N16	SocketModem® iCell – EV-DO Rev. A Universal IP – Aeris – Serial	USA	
MTSMC-EV2-GP-N16	SocketModem® iCell – EV-DO Rev. A GPS/ Universal IP – Aeris – Serial	USA	
MTSMC-EV2-MI-IP-N16	SocketModem® iCell – EV-DO Rev. A Universal IP – Aeris – USB+Serial+GPIO	USA	
MTSMC-EV2-MI-GP-N16	SocketModem® iCell – EV-DO Rev. A GPS/ Universal IP – Aeris – USB+Serial+GPIO	USA	
MTSMI-UDK	Universal Developer Kit	Global	

How to Read the Product Codes in the Table Above:

EV2	CDMA EV-DO Rev. A
IP	Universal IP™ Stack
GP	Dedicated GPS Receiver
MI	Multiple Interface
N2	Sprint
N3	Verizon Wireless
N16	Aeris Communications, Inc.
UDK	Universal Developer Kit

Other Product Codes:

The complete product code may end in .Rx. For example, MTSMC-EV2-IP.Rx. "R" indicates product revision. "x" is the revision number.

AT Commands Reference Guide

Product	Reference Guides Title and Document Product Number	Fax Commands	Voice Commands
SocketModem iCell – EV-DO (MTSMC-EV2)	SocketModem iCell – EV-DO Rev. A – AT Commands Reference Guide (S000482x)	NA	NA
SocketModem iCell – EV-DO (MTSMC-EV2-IP, -GP)	SocketModem iCell – EV-DO Rev. A – AT Commands Reference Guide (S000482x) and Universal IP Commands (S000457x)	NA	NA

Technical Specifications

The SocketModem Cell and SocketModem iCell EV-DO (MTSMC-EV2) meet the following specifications:

Category	Description
Standard	CDMA2000 1xRTT EV-DO Rev. A (backward compatible to EV-DO Rev. 0 and CDMA 1x networks) SMS is based on CS/Packet-Switched (PS) domain of GSM and WCDMA
Data Speed	Serial interface supporting DTE speeds to 230K Peak downlink speeds up to 3.1 Mbps Peak uplink speeds up to 1.8 Mbps IS-95 Circuit-switched data up to 14.4K bps
Frequency Bands	Dual-band 800/1900 MHz bands with Receive Diversity support on both bands
Dimensions	3.15" x 1.375" (80.010 mm x 34.925 mm)
Weight	1.0 oz (28 g)
SMS	Point-to-Point messaging Mobile-Terminated SMS Mobile-Originated SMS
USB Interface	USB 2.0 full speed (12 Mbit/s) – MI builds only
Serial Modem Interface	Up to 921.6 Kbps
Ports	4 GPIO ports – MI builds only
Connectors	Antenna: All models have surface mount UFL antenna connectors. Standard and Rx diversity antennas are also supported. GPS models support an additional UFL antenna.
Operating Temperature	-30° to +75° C
Storage Temperature	-40° to +85° C
Humidity	20% to 90% (non-condensing)
Operating Voltage	5VDC ± 10%
Compliance	EMC Compliance FCC Part 15 Class B Radio Compliance FCC Part 22 FCC Part 24 Safety Compliance UL 60950-1 IEC 60950-1 Network Compliance CDG 1&2
Warranty	2 years

Note: The radio's performance may be affected at the temperature extremes. This is considered normal. The radio is designed to automatically fallback in class and reduces transmitter power to avoid damage to the radio. There is no single cause for this function. Rather, it is the result of an interaction of several factors, such as the ambient temperature, the operating mode and the transmit power.

Important

MTSMC Tooling Holes and Mounting Hardware

It is recommended that nylon hardware be used if the SocketModems are to be mounted using the two tooling holes due to possible traces and vias around the tooling holes. #4 or M2/M3 hardware should be used for mounting.

This applies to the SocketModem® Cell & SocketModem® iCell - EV-DO (MTSMC-EV2)

Note: See the Mechanical Drawings for MTSMC-EV-DO on the following three pages.

Mechanical Drawings – Basic Build

Mechanical Drawings – IP Build

Mechanical Drawings – GPS Build

DC Electrical Characteristics

5VDC Characteristics VDD = 5V (± 0.5V)			
Digital Inputs –DTR (40), –TXD (35), –RTS (33)	Input High Min 2.0V	Input Low Max 0.8V	
–RESET	Input High Min 2.0V	Input Low Max 0.8V	
Digital Outputs –DCD (39), –CTS (38), –DSR (37), –RI (36), –RXD (34)	Output High Min 3.8V	Output Low Max 0.55V	Current Drive: 4mA
Digital Input Capacitance			10 pF

Electrical Specifications

Pin	Signal Name	V _{IL}		V _{IH}		V _{OL}		V _{OH}	
		Min	Max	Min	Max	Min	Max	Min	Max
J18	SPI SPCK	--	--	--	--		0.3	2.9	
J19	SPI MISO	-0.3	0.7	2.0	5.5	--	--	--	--
J20	SPI MOSI	--	--	--	--		0.3	2.9	
J21	SPI CS	--	--	--	--		0.3	2.9	
J24	–RESET		0.8	2.0		--	--	--	--
J25	USB VBUS	-0.3	0.8	2.0	8.7	--	--	--	--
J26	GND	--	--	--	--	--	--	--	--
J27	USB DP		0.8	2			0.3	2.8	
J28	USB DM		0.8	2			0.3	2.8	
J33	–RTS	-0.3	0.8	2.0	5.5	--	--	--	--
J34	–RXD	--	--	--	--		0.26	3.98	
J35	–TXD	-0.3	0.8	2.0	5.5	--	--	--	--
J36	–RI	--	--	--	--		0.55	3.8	
J37	–DSR	--	--	--	--		0.26	3.98	
J38	–CTS	--	--	--	--		0.26	3.98	
J39	–DCD	--	--	--	--		0.26	3.98	
J40	–DTR	-0.3	0.8	2.0	5.5	--	--	--	--
J41	GND	--	--	--	--	--	--	--	--
J44	PCM OUT	--	--	--	--	0	0.45	2.2	2.7
J45	PCM IN	0	0.91	1.7	2.9	--	--	--	--
J46	PCM SYNC	--	--	--	--	0	0.45	2.2	2.7
J47	PCM CLK	--	--	--	--	0	0.45	2.2	2.7
J48	GPIO0	-0.3	0.8	2.0	5.5		0.4	2.9	
J49	GPIO1	-0.3	0.8	2.0	5.5		0.4	2.9	
J50	GPIO2	-0.3	0.8	2.0	5.5		0.4	2.9	
J51	GPIO3	-0.3	0.8	2.0	5.5		0.4	2.9	
J55	HEARTBEAT	--	--	--	--		0.4	2.9	
J58	–LED LINK	--	--	--	--	0	0.45	2.85	3.3
J61	VCC	--	--	--	--	--	--	--	--
J63	GND	--	--	--	--	--	--	--	--

Absolute Maximum Rating:

VCC Voltage (Survival) -0.3V to +5.5V

Pin-Out Specifications

Pin	Signal Name	Logic Level Voltage*	I/O	Description
J18	SPI SPCK	3.3	O	SPI clock signal
J19	SPI MISO	3.3	I	SPI master-in/slave-out
J20	SPI MOSI	3.3	O	SPI master-out/slave-in
J21	SPI CS	3.3	O	SPI chip select
J24	-RESET	3.3 – 5.0	I	Device reset (active low)
J25	USB VBUS	3.3 – 5.0	I	USB power supply input
J26	GND	GND	GND	Ground
J27	USB DP	3.3	I/O	USB data
J28	USB DM	3.3	I/O	USB data
J33	-RTS	5.0	I	Request to send (active low)
J34	-RXD	5.0	O	Received data (active low)
J35	-TXD	5.0	I	Transmitted data (active low)
J36	-RI	5.0	O	Ring indicator (active low)
J37	-DSR	5.0	O	Data set ready (active low)
J38	-CTS	5.0	O	Clear to send (active low)
J39	-DCD	5.0	O	Data carrier detect (active low)
J40	-DTR	5.0	I	Data terminal ready (active low)
J41	GND	GND	GND	Ground
J44	PCM OUT	2.6	O	PCM data output
J45	PCM IN	2.6	I	PCM data input
J46	PCM SYNC	2.6	O	PCM frame synchronization
J47	PCM CLK	2.6	O	PCM clock
J48	GPIO0	3.3	I/O	User configurable general purpose I/O
J49	GPIO1	3.3	I/O	User configurable general purpose I/O
J50	GPIO2	3.3	I/O	User configurable general purpose I/O
J51	GPIO3	3.3	I/O	User configurable general purpose I/O
J55	HEARTBEAT	3.3	O	Heartbeat from processor
J58	-LED LINK	3.3	O	Link status (active low, can sink up to 150mA)
J61	VCC	5.0	PWR	DC input power
J63	GND	GND	GND	Ground

*Note: A hyphen (-) indicates a range of acceptable logic levels.

Serial Model Pin Out

24, 26, 33-41, 61, 63

For Products: MTSMC-EV2-IP-xx, MTSMC-EV2-GP-xx

USB + Serial + GPIO + Voice + GPS Data Pin Out

For Products: MTSMC-EV2-MI-IP-xx, MTSMC-EV2-MI-GP-xx

Pins Available With Current PCB: 24-28, 33-41, 48-51, 58, 61, 63

Pins to Be Added to the Next PCB Revision: 16-17, 22-28, 33-43, 48-51, 58, 61, 63, new GPS data pin

Design Consideration - Very Important Note

The current revision of the PCB will not accommodate the following pins:
22-23, 42-43 and the new GPS data pins 16-17.

While these pins are not present at this time, they will be present on the next hardware release.

You, as the developer, must take these new pins into account in your product design even if you have no plans for using them.

Power Measurements

Power Draw* for the MTSMC-EV2-IP and MTSMC-EV2-MI-IP

Input Voltage = 5.0 Volts	Sleep Mode	Typical	Maximum
CDMA 2000			
Current (AMPS)	0.088	0.240	0.770
Watts	0.44	1.19	3.78
EVDO			
Current (AMPS)	0.173	0.400	1.200
Watts	0.85	1.98	

Power Draw* for the MTSMC-EV2-GP and MTSMC-EV2-MI-GP

Input Voltage = 5.0Volts	Sleep Mode	Typical	Maximum
CDMA 2000			
Current (AMPS)	0.173	0.330	0.890
Watts	0.85	1.63	4.33
EV-DO			
Current (AMPS)	0.180	0.420	1.200
Watts	0.85	1.98	

* Multi-Tech Systems, Inc. recommends that the customer incorporate a 10% buffer into their power source when determining product load.

Application Notes

LED Interface

The LED signal is used to indicate the working status of the SocketModem.

LED 1 – Heartbeat LED – Available for -IP and -GP Builds

LED 1 Signal	Heartbeat LED
OFF	No power to the unit
Blinking	Power on

LED 2 – Link Status – Available for All Builds

LED 2 Signal	Link Status LED
OFF	No power to the unit
Continuously Lit	Powered and connected, but not transmitting or receiving
Slow Blink (~0.2 Hz)	Powered and searching for a connection
Faster Blink (~3 Hz)	Transmitting or receiving

LED 3 – Signal Strength – Available for -IP and -GP Builds

LED 3 Signal	Signal Strength LED
OFF	No signal
Blinking	The faster the LED blinks, the stronger the signal. The range for the blink rate is from ~0.5Hz to ~10Hz.

LED 4 – GPS Status – Available for -GP Build

LED 4 Signal	GPS Status LED
OFF	No power to the unit
Continuously Lit	Satellite not acquired
Blinking	Satellite acquired

RF Interface

Radio Characteristics

	CDMA 800	CDMA 1900
Frequency RX	869 to 894 MHz	1930 to 1990 MHz
Frequency TX	824 to 849 MHz	1850 to 1910 MHz
Impedance	50 ohms	
VSWR	<2	
Typical Radiated Gain	0 dBi in at least one direction	
Output Power	.25W in CDMA	

RF Connection and Antenna

The RF connector on the SocketModem is a UFL standard type. See Chapter 1 for Antenna System details.

Baud Rate Switches on the SocketModem iCell

Note: For the serial interface.

ON

				921600
•	•	•	•	
1	2	3	4	

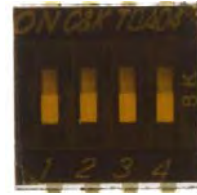

ON

•				460800
	•	•	•	
1	2	3	4	

ON

	•			230400
•		•	•	
1	2	3	4	

ON

•	•			115200
		•	•	
1	2	3	4	

ON

		•		57600
•	•		•	
1	2	3	4	

ON

•		•		38400
	•		•	
1	2	3	4	

ON

	•	•		19200
•			•	
1	2	3	4	

ON

•	•	•		9600
			•	
1	2	3	4	

ON

			•	+IPR/USB enable
•	•	•		
1	2	3	4	

ON

•	•	•	•	+IPR
1	2	3	4	

Default

Part 3

Analog SocketModems

Chapter 7 – SocketModem (MT9234SMI)

Chapter 8 – SocketModem (MT5692SMI)

Chapter 9 – SocketModem (MT2492SMI)

Chapter 7 – SocketModem® (MT9234SMI)

Introduction

Multi-Tech's SocketModem creates communication-ready devices by integrating data/fax/voice functionality into a single product design. The SocketModem is a space-efficient (1" x 2.5"), embedded modem that provides V.92/56K communication. The complete, ready-to-integrate modem dramatically reduces development time and costs for system designers.

The MT9234SMI SocketModems are used for integrating data and fax communications. They are single-port modems that integrate the controller, DSP, and DAA in a 1" x 2.5" form factor and communicate to a host controller via an asynchronous serial interface.

Product Build Options and Ordering Information

Product	Description	Region	Order this Product ✓
MT9234SMI			
MT9234SMI-92	V.92 Serial Data, V.34 Fax, 5V	Global	
MT9234SMI-L-92	V.92 Serial Data, V.34 Fax, 3.3V	Global	
MT9234SMI-P-92	V.92 Parallel Data, V.34 Fax, 5V	Global	
MT9234SMI-P-L-92	V.92 Parallel Data, V.34 Fax, 3.3V	Global	
MT9234SMI-HV-92	V.92 Serial Data, V.34 Fax, High Voltage, 5V	Global	
MT9234SMI-P-HV-92	V.92 Parallel Data, V.34 Fax, High Voltage, 5V	Global	
Telecom Label			
MT9234SMI-LS	MT9234SMI – Global Regulatory Label	Global	
Developer Kits			
MTSMI-UDK	Universal Developer Kit	Global	
MTSMI-P-UDK	SocketModem Parallel Developer Kit	Global	

How to Read the Product Codes in the Table Above:

92	V.92/56K data rate
HV	High Voltage 2KV Dielectric Isolation (EN60601)
L	3.3V
P	Parallel interface
LS	Telecom Label
UDK	Universal Developer Kit

Other Product Codes:

The complete product code may end in **.Rx**. For example, MT9234SMI-92.Rx. "R" indicates product revision. "x" is the revision number.

AT Commands Reference Guide

Product	Reference Guides Title and Document Product Number	Fax Commands	Voice Commands
SocketModem (MT9234SMI)	MT9234SMI AT Commands Reference Guide (S000434x)	See separate Fax Guides: Class 1: S000262x Class 2 S000239x	Included in S000434x

Technical Specifications

The SocketModem (**MT9234SMI**) meets the following specifications:

Category	Description
Data Standards	V.92, V.34 enhanced, V.34, V.32bis, V.32, V.22bis, V.22; Bell 212A and Bell 103
Data Format	Serial, or 8-bit parallel interface, asynchronous
Character Format	10 bit or 11 bit
Serial/Data Speeds	Serial port data rates adjustable to 300, 1200, 2400, 4800, 9600, 19200, 38400, 57600, 115200, and 230400 bps
Client-to-Client Data Rates	33600, 31200, 28800, 26400, 24000, 21600, 19200, 16800, 14400, 12000, 9600, 7200, 4800, 2400, 1200, 0-300 bps
Data Error Correction (ECM)	V.44; V.42 (LAPM, MNP 2-4)
Data Compression	V.42bis, MNP 5
Fax Compatibility	V.17, V.29/V.27/V.21, V.34
Fax Class	Class 1 & 1.0 – All builds Class 2, 2.0/2.1 – All builds
Fax Compression	MH, MR, MMR
Fax Error Correction Mode	ECM
Modes of Operation	Fax online modes; full duplex over dial-up or 2-wire leased lines; data mode; command mode; online command mode; V.54 test mode
Weight	0.6 oz. (0.017 kg.)
Operating Temperature	-40° to +85° C
Storage Temperature	-40° to +85° C
Humidity	20% to 90% (non-condensing)
Operating Voltage	3.3V and 5V
Transmit Level	- 11 dBm (varies by country setting)
Receiver Sensitivity	- 43 dBm under worst-case conditions
DAA Isolation	1.5Kv r.m.s. or 2121 VDC at working voltage of 250VAC 2Kv r.m.s. or 2828 VDC at working voltage of 125VAC
Flow Control	XON/XOFF (software), RTS/CTS (hardware)
Command Buffer	60 characters
Telephony / TAM	TAM: S-101 AT+V commands (no CODEC for speakers/microphone interface)
Compliance	<p>EMC Compliance</p> <ul style="list-style-type: none"> FCC Part 15 Canadian EMC EN 55022 EN 55024 GB4943, GB9254 <p>Safety Compliance</p> <ul style="list-style-type: none"> UL 60950 cUL 60950 EN 60950 AS/NZS 60950:2000 CCC <p>Safety Compliance for HV Builds</p> <ul style="list-style-type: none"> UL 60601-1 EN 60601-1
Warranty	2 years

Mechanical Drawings – Basic and HV Builds

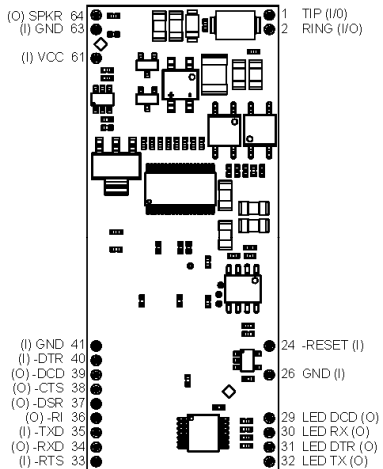
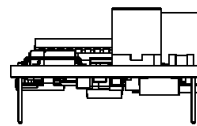
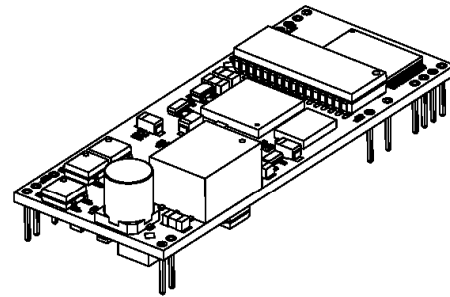

MT9234SMI-92
MT9234SMI-L-92
MT9234SMI-HV-92

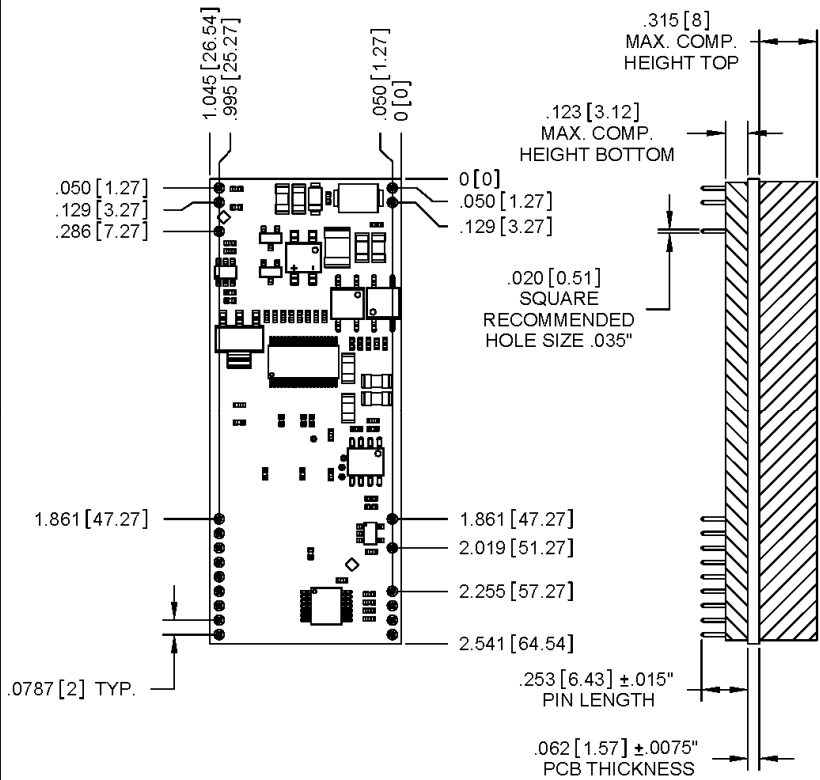

DIMENSIONS IN In [mm]

Mechanical Drawings – Parallel Builds

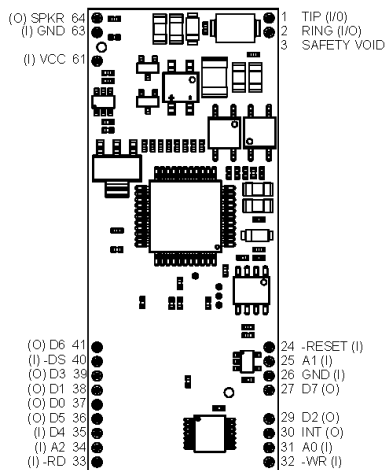
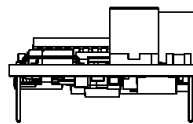
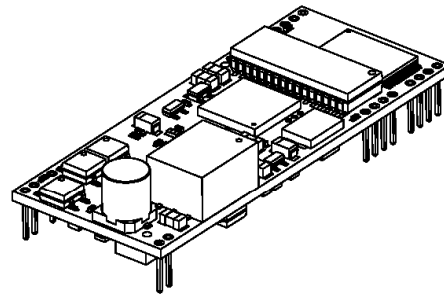

MT9234SMI-P-92
MT9234SMI-P-L-92
MT9234SMI-P-HV-92

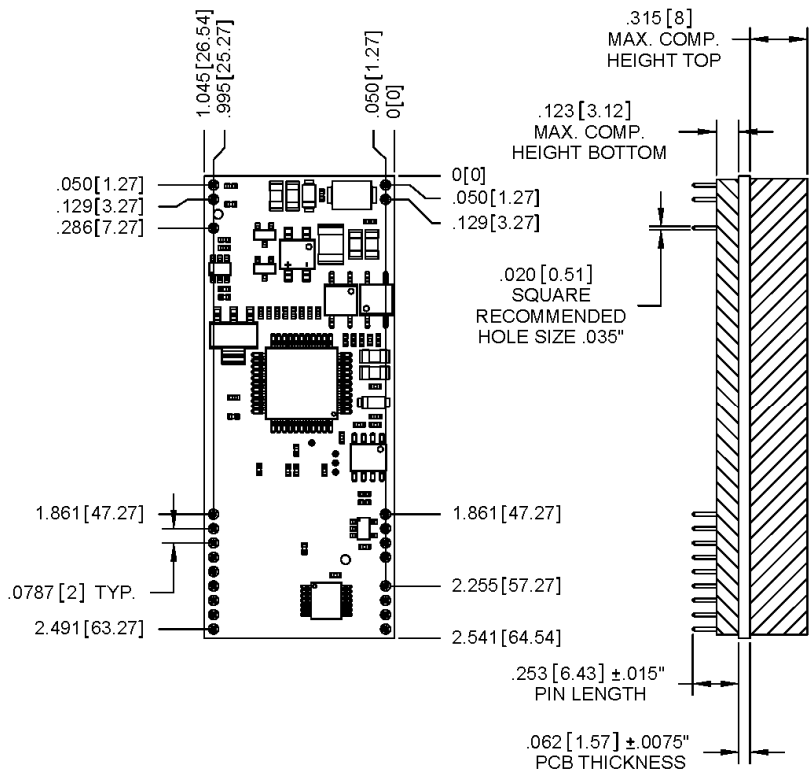

DIMENSIONS IN In [mm]

DC Electrical Characteristics

5V Serial – Standard (SMI) and Medical Device (SMI-HV) Build Options

5VDC Characteristics (VDD = 5V ± 0.25V) VDDMAX = 5.25V

Digital Inputs –DTR (40), –TXD (35), –RTS (33)	Input High Min 2.52V	Input Low Max .9V	
–Reset (24)	Input High Min 2.52V	Input Low Max 0.3V	
Digital Outputs –DCD (39), –CTS (38), –DSR (37), –RI (36), –RXD (34)	Output High Min 2.3V	Output Low Max 0.4V	Current Drive 2mA
Digital Input Capacitance			5 pF

5V Parallel – Standard (SMI) and Medical Device (SMI-HV) Build Options

5VDC Characteristics (VDD = 5V ± 0.25V) VDDMAX = 5.25V

Digital Inputs –DS (40)	Input High Min 2.52V	Input Low Max 0.9V	
Digital Inputs (hysteresis input buffer) A0 (31), A1 (25), A2 (34), –WR (32), –RD (33)	Input High Min 2.52V	Input Low Max 0.9V	
Digital Input / Output Output buffer can source 12 mA at 0.4 V DO (37), D1 (38), D2 (29), D3 (39), D4 (35), D5 (36), D6 (41), D7 (27)	Input High Min 2.52V	Input Low Max 0.9V	
Digital Output INT (30)	Output High Min 2.3V	Output Low Max 0.4V	Current Drive 2mA
Digital Input Capacitance			5 pF

3.3V Serial – Industrial Temperature (SMI-L) Build Option

3.3VDC Characteristics (VDD = 3.3V ± 0.3V) VDDMAX = 3.6V

Digital Inputs –DTR (40), –TXD (35), –RTS (33)	Input High Min 2.52V	Input Low Max 0.9V	
–Reset (24)	Input High Min 2.52V	Input Low Max 0.3V	
Digital Outputs –DCD (39), –CTS (38), –DSR (37), –RI (36), –RXD (34)	Output High Min. 2.3V	Output Low Max 0.4V	Current Drive 2mA
Digital Input Capacitance			5 pF

3.3V Parallel – Industrial Temperature (SMI-L) Build Options

3.3VDC Characteristics (VDD = 3.3V ± 0.3V) VDDMAX = 3.6V

Digital Inputs –DS (40)	Input High Min 2.52V	Input Low Max 0.9V	
Digital Inputs (hysteresis input buffer) A0 (31), A1 (25), A2 (34), –WR (32), –RD (33)	Input High Min 2.52V	Input Low Max 0.9V	
Digital Input/Output Output buffer can source 12 mA at 0.4 V DO (37), D1 (38), D2 (29), D3 (39), D4 (35), D5 (36), D6 (41), D7 (27)	Input High Min 2.52V	Input Low Max 0.9V	
Digital Output INT (30)	Output High Min 2.3V	Output Low Max 0.4V	Current Drive 2mA
Digital Input Capacitance			5 pF

Power Measurements

MT9234SMI-L 3.3 Volt Power* Measurements:

Input Voltage = 3.3 Volts	Sleep Mode	Typical	Maximum
Current (AMPS)	0.081	0.114	0.122
Watts	0.264	0.373	0.397

MT9234SMI 5 Volt Power* Measurements:

Input Voltage = 5.0 Volts	Sleep Mode	Typical	Maximum
Current (AMPS)	0.082	0.116	0.122
Watts	0.409	0.579	0.606

MT9234SMI-P (Parallel Build) 3.3 Volt Power* Measurements:

Input Voltage = 3.3 Volts	Sleep Mode	Typical	Maximum
Current (AMPS)	0.079	0.112	0.116
Watts	0.260	0.366	0.378

MT9234SMI-P (Parallel Build) 5 Volt Power* Measurements:

Input Voltage = 5.0 Volts	Sleep Mode	Typical	Maximum
Current (AMPS)	0.079	0.114	0.119
Watts	0.394	0.567	0.589

* Multi-Tech Systems, Inc. recommends that the customer incorporate a 10% buffer into their power source when determining product load.

Parallel Timing Requirements

Timing Requirements for Parallel Write

Parameter	Min	Max	Unit
–DS to –WR Setup (low to low)	10	-	ns
A0, A1, A2 to –WR Setup (valid to low)	15	-	ns
–WR Pulse Width (low to high)	40	-	ns
D0–D7 to –WR Setup (valid to high)	30	-	ns
–WR to –DS hold (high to high)	0	-	ns
–WR to A0–A2 Hold (high to invalid)	0	-	ns
–WR to D0–D7 Hold (high to invalid)	0	-	ns
–WR interaccess (high to low)			
Non-MIMIC Accesses	10	-	ns
MIMIC Accesses	110	-	ns

Timing Requirements for Parallel Read

Parameter	Min	Max	Unit
–DS to –RD Setup (low to low)	10	-	ns
A0, A1, A2 to –RD Setup (valid to low)	15	-	ns
–RD Pulse Width (low to high)	40	-	ns
–RD to –DS hold (high to high)	0	-	ns
–RD to A0–A2 Hold (high to invalid)	0	-	ns
–WR interaccess (high to low)			
Non-MIMIC Accesses	10	-	ns
MIMIC Accesses	110	-	ns

Pin Descriptions for a Parallel SocketModem Device

Pin #	Signal	I/O	Description								
1	Tip	I/O	Tip Signal from Telco. Tip connection to the phone line (RJ-11 Pin 4). The SocketModem is Tip/Ring polarity insensitive.								
2	Ring	I/O	Ring Signal from Telco. Ring connection to the phone line (RJ-11 Pin 3). The SocketModem is Tip/Ring polarity insensitive.								
24	–RESET	I	<p>Device Reset (with pull-up). The active low –RESET input resets the device logic and returns the configuration of the device to the original factory default values or "stored values" in the NVRAM.</p> <p>–RESET is tied to VCC through a time-constant circuit for "Power-on-Reset" functionality. The SocketModem is ready to accept commands after a fixed amount of time ("X" Time) after power-on or reset.</p> <table border="1"> <thead> <tr> <th>Model</th> <th>Time Constant</th> <th>"X" Time</th> <th>Minimum Reset Pulse*</th> </tr> </thead> <tbody> <tr> <td>MT9234SMI</td> <td>400 ms</td> <td>6 seconds</td> <td>100us</td> </tr> </tbody> </table> <p>*The SocketModem device may respond to a shorter reset pulse.</p> <p>Modem Reset (with weak pull-up). The active low –RESET input resets the SocketModem logic and returns the AT command set to the original factory default values or to "stored values" in NVRAM. The modem is ready to accept commands within 6.5 seconds of power-on or reset. Reset must be asserted for a minimum of 300 ns.</p>	Model	Time Constant	"X" Time	Minimum Reset Pulse*	MT9234SMI	400 ms	6 seconds	100us
Model	Time Constant	"X" Time	Minimum Reset Pulse*								
MT9234SMI	400 ms	6 seconds	100us								
25	A0	I	Host Bus Address Line 0. During a host read or write operation, A0 selects an internal 16C450 or 16C550-compatible register. The state of the divisor latch access bit (DLAB) affects the selection of certain registers.								
26	DGND	GND	Digital Ground								
30	INT	O	Host Bus Interrupt. INT output is set high when the receiver error flag, receiver data available, transmitter holding register empty, or modem status interrupt have an active high condition. INT is reset low upon the appropriate interrupt service or master reset operation.								
31	A1	I	Host Bus Address Line 1. During a host read or write operation, A1 selects an internal 16C450 or 16C550-compatible register. The state of the divisor latch access bit (DLAB) affects the selection of certain registers.								
32	–WR	I	Host Bus Write. –WR is an active low, write control input. When –DS is low, –WR low allows the host to write data or control words into a selected modem register.								
33	–RD	I	Host Bus Read. –RD is an active low, read control input. When –DS is low, –RD low allows the host to read status information or data from a selected modem register.								
34	A2	I	Host Bus Address Line 2. During a host read or write operation, A2 selects an internal 16C450 or 16C550-compatible register. The state of the divisor latch access bit (DLAB) affects the selection of certain registers.								
40	–DS	I	Host Bus Device Select. –DS input low enables the modem for read or write.								
61	VCC	PWR	+5V or 3.3V Supply (depends upon model).								
63	AGND	GND	Analog Ground. This is tied common with DGND on the SocketModem. To minimize potential ground noise issues, connect audio circuit return to AGND.								
64	SPKR	O	<p>Speaker. Dual purpose output for call progress signals or speakerphone functions.</p> <p>Call Progress on the MT9234SMI is an analog output.</p>								

SocketModem Parallel Interface Internal Registers

The SocketModem parallel interface is a mimic of a 16C550A UART. It is similar to the MIMIC interface used in the Zilog Z80189. The SocketModem mimic (MMM) takes advantage of this standard interface while replacing the serial to parallel data transfer with a less complicated parallel to parallel data transfer.

The MMM interface controls an 8-bit parallel data transfer which is typically interrupt driven. Interrupts usually indicate one or both of two conditions: (1) the receive (RX) FIFO has either reached a trigger level or time-out condition and needs to be emptied and/or (2) the transmit (TX) FIFO is empty and waiting for more data from the Host. An interrupt can also be triggered by a change in the modem status register (i.e., loss of carrier) or by the occurrence of errors in the line status register (overrun, parity, framing, break detect).

In addition to the receive and transmit FIFOs, there are twelve other control/status registers called the MMM register set which can be accessed through this interface.

Overview

SocketModem MIMIC (MMM) Operation

Data flow through MMM is bi-directional. Simultaneously, data can flow from the host through the transmit FIFO to the SocketModem controller, and data can flow from SocketModem controller through the receive FIFO to the Host. In the receive path, 8-bit data is asynchronously received (from the SocketModem controller) by the receive FIFO where it is stored along with associated three error bits. The error bits must arrive (via a SocketModem controller I/O write to MMM shadow line status register) prior to receiving the actual data bits. The error bits are then temporarily stored so they may be written, with associated data bits, to the 11-bit wide RX FIFO.

After every data write, the RX FIFO write pointer is incremented. RX FIFO trigger levels, data ready signal, and time-out counter are checked to see if a Host-interrupt needs to be sent. The data ready signal will be activated and MMM sits poised to accept another data word.

We highly recommend the host should read the MMM IIR register to determine the type of interrupt. Then it might check bit 7 of the LSR to see if there are any errors in the data currently residing in the receive FIFO. Finally, it will (1) alternately read a data word through the RX FIFO read pointer and the error bits via the MMM LSR until the FIFO is empty, or (2) read successive data words (knowing there were no errors in the FIFO) until the trigger count is met.

A similar sequence occurs when data flows in the other direction (from host through transmit FIFO), except there is no error bit manipulation/checking involved.

FIFO Operation

The 16-byte transmit and receive data FIFOs are enabled by the FIFO Control Register (FCR) bit-0. You can set the receive trigger level via FCR bits 6/7. The receiver FIFO section includes a time-out function to ensure data is delivered to the external host. An interrupt is generated whenever the Receive Holding Register (RHR) has not been read following the loading of a character or the receive trigger level has been reached.

Receive (RX) FIFO

The RX FIFO can be configured to be 16 words deep and 11 bits wide. Each word in the RX FIFO consists of 8 data bits and 3 error bits. The RX block of the MMM contains read and write pointers and status flag circuitry that need only to be presented with data (for input), reset, read/write control signals, and read/write clock signals. The RX block of the MMM internally manages the FIFO register file and pointers, and it provides simultaneous read/write capability (no contention problems).

The RX block of the MMM provides data (for output), FIFO full flag, FIFO empty flag, and an almost full flag which uses an associated predefined trigger level (obtained from the MMM FCR control register) to signal when the trigger level has been met. Four possible trigger levels may be selected by programming bits 6-7 of the FCR control register.

A typical (interrupt driven) write to the RX block is a two-step process. The MMM micro-controller must first write the 3 error bits to a shadow MMM LSR status register. Next, the micro-controller writes the data to the RX FIFO and during this write operation, the 3 error bits are directly loaded from the LSR shadow register into the bits 8-10 of the selected (11 bit-wide) FIFO register. These error bits represent the parity error, framing error, and break interrupt signals associated with each data work transmission into the receive FIFO. When the receive FIFO is read, these error bits are loaded directly into bits 2-4 of the MMM LSR register.

A2	A1	A0	Register Name	Register Description	Host Access
0	0	0	RBR	Receive Buffer (RX FIFO)	DLAB = 0 R only
0	0	0	THR	Transmit Holding (TX FIFO)	DLAB = 0 W only
0	0	1	IER	Interrupt Enable	DLAB = 0 R/W
0	1	0	IIR	Interrupt Identification	DLAB = X R only
0	1	0	FCR	FIFO Control	DLAB = X W only
0	1	1	LCR	Line Control	DLAB = X R/W
1	0	0	MCR	Modem Control	DLAB = 0 R/W
1	0	1	LSR	Line Status	DLAB = X R only
1	1	0	MSR	Modem Status	DLAB = X R only
1	1	1	SCR	Scratch pad	DLAB = 0 R/W
0	0	0	DLL	LSB of Divisor Latch	DLAB = 1 R/W
0	0	1	DLM	MSB of Divisor Latch	DLAB = 1 R/W
1	1	1	DLX	Divisor Latch	DLAB = 1 R/W
1	0	0	MCX	Status/Control	DLAB = 1 R/W

Note 1* The General Register set is accessible only when DS is a logic 0.

Note 2* The Baud Rate register set is accessible only when DS is a logic 0 and LCR bit-7 is a logic 1.

Time Out Interrupts

The interrupts are enabled by IER bits 0-3. Care must be taken when handling these interrupts. Following a reset the transmitter interrupt is enabled, the SocketModem will issue an interrupt to indicate that transmit holding register is empty. This interrupt must be serviced prior to continuing operations.

The LSR register provides the current singular highest priority interrupt only. A condition can exist where a higher priority interrupt may mask the lower priority interrupt(s). Only after servicing the higher pending interrupt will the lower priority interrupt(s) be reflected in the status register. Servicing the interrupt without investigating further interrupt conditions can result in data errors. When two interrupt conditions have the same priority, it is important to service these interrupts correctly.

Receive Data Ready and Receive Time Out have the same interrupt priority (when enabled by IER bit-3). The receiver issues an interrupt after the number of characters received have reached the programmed trigger level. In this case the MMM FIFO may hold more characters than the programmed trigger level. Following the removal of a data byte, the user should recheck LSR bit-0 for additional characters. A Receive Time Out will not occur if the receive FIFO is empty. The time out counter is reset at the center of each stop bit received or each time the receive holding register (RHR) is read.

Register Functional Definitions

The following table delineates the assigned bit functions for the twelve internal registers. The assigned bit functions are more fully defined in the following paragraphs.

Internal Registers

A2 A1 A0	Register [Default] Note *3	BIT-7	BIT-6	BIT-5	BIT-4	BIT-3	BIT-2	BIT-1	BIT-0
General Register Set: Note 1*									
0 0 0	RBR [XX]	Bit-7	Bit-6	Bit-5	Bit-4	Bit-3	Bit-2	Bit-1	Bit-0
0 0 0	THR [XX]	Bit-7	Bit-6	Bit-5	Bit-4	Bit-3	Bit-2	Bit-1	Bit-0
0 0 1	IER [00]	0	0	0	0	Modem Status Interrupt	Receive Line Status interrupt	Transmit Holding Register interrupt	Receive Holding Register interrupt
0 1 0	IIR [XX]	FIFO enable	FIFO enable	0	0	Interrupt ID	Interrupt ID	Interrupt ID	Interrupt Pending
0 1 0	FCR [00]	RX Trigger (MSB)	RX trigger (LSB)	Detect change in FCR	TX FIFO overrun bit	0	XMIT FIFO reset	RCVR FIFO reset	FIFO enable
0 1 1	LCR [00]	Divisor latch access (DLAB)	Set break	Stick parity	Even parity	Parity enable	0	Word length bit-1	Word length bit-0
1 0 0	MCR [00]	0	0	0	0	INT enable	OUT 1	-RTS	-DTR
1 0 1	LSR [60]	RX FIFO data error	TX empty THR empty	THR Empty	Break interrupt	Framing error	Parity error	Overrun error	Receive data ready
1 1 0	MSR [X0]	CD	RI	DSR	CTS	Delta -CD	Delta -RI	Delta -DSR	Delta -CTS
1 1 1	SCR [FF]	Bit-7	Bit-6	Bit-5	Bit-4	Bit-3	Bit-2	Bit-1	Bit-0
Special Register Set: Note *2									
0 0 0	DLL [00]	Bit-7	Bit-6	Bit-5	Bit-4	Bit-3	Bit-2	Bit-1	Bit-0
0 0 1	DLM [00]	Bit-7	Bit-6	Bit-5	Bit-4	Bit-3	Bit-2	Bit-1	Bit-0

- Notes:** 1* The General Register set is accessible only when DS is a logic 0.
 2* The Baud Rate register set is accessible only when DS is a logic 0 and LCR bit-7 is a logic 1.
 3* The value between the square brackets represents the register's initialized HEX value, X = N/A.

RBR – Receive Buffer (RX FIFO)

All eight bits are used for receive channel data (host read/data in; host write/data out). The three error bits per byte are copied into bits 2, 3, and 4 of the LSR during each host I/O read; therefore, they are available for monitoring on a per-byte basis.

THR – Transmit Holding Register (TX FIFO)

All eight bits are used for transmit channel data (host write/data out; host read/data in).

IER – Interrupt Enable

- Bits 4–7:** Reserved and will always read 0.
- Bits 0-3:** Set by host software only and cleared by software control or host reset.
- Bit 3:** Enables modem status IRQ. If bits 0–3 of the MSR are set and this bit is set to 1 (enabled), a host interrupt is generated.
- Bit 2:** Enables receive line status IRQ. If bits 1–4 (overrun, parity, framing, break errors) of the LSR are set and this bit is set to a logic 1, a host interrupt is generated.
- Bit 1:** Enables transmit holding register IRQ. If bit 5 (transmit holding register empty) of the LSR is set and this bit is set to a 1, a host interrupt is generated.
- Bit 0:** Enables received data available IRQ. If bit 0 (data ready) of the LSR is set and this bit is set to a 1, a host interrupt is generated.

IIR – Interrupt Identification (Read Only)

Bits 6–7: (FIFO enabled bits). These bits will read a 1 if FIFO mode is enabled and the 16450 enable bit is 0 (no force of 16450 mode).

Bits 4–5: Reserved and always read a 0.

Bits 1–3: Interrupt ID bits.

Bit 0: Interrupt pending. If logic 0 (in default mode), an interrupt is pending.

When the host accesses IIR, the contents of the register are frozen. Any new interrupts will be recorded, but not acknowledged during the IIR access. This requires buffering bits (0–3, 6–7) during IIR reads.

Interrupt Sources and Reset Control Table

Bit 3	Bit 2	Bit 1	Priority	Interrupt Source	Interrupt Reset Control
0	1	1	Highest	Overrun, parity, framing, error or break detect bits set by SocketModem Controller	Reading the LSR
0	1	0	2 nd	Received data trigger level	RX FIFO drops below trigger level
1	1	0	2 nd	Receiver time-out with data in RX FIFO	Read RX FIFO
0	0	1	3 rd	TX holding register empty	Writing to TX holding register or reading IIR when TX holding register is source of error
0	0	0	4 th	MODEM status: CTS, DSR, RI or DCD	Reading the MSR

FCR – FIFO Control

Bits 6–7: Used to determine RX FIFO trigger levels.

Bit 5: Used to detect a change in the FCR.

Bit 4: TX FIFO overrun bit.

Bit 3: DMA mode select. Must be set to zero. When bit 3 is a 0, the 16450 mode is enabled which does only single-byte transfers.

Bit 2: TX FIFO reset. This will cause TX FIFO pointer logic to be reset (any data in TX FIFO will be lost). This bit is self clearing; however, a shadow bit exists that is cleared only when read by the host, thus allowing the host to monitor a FIFO reset.

Bit 1: RX FIFO reset. This will cause RX FIFO pointer logic to be reset (any data in RX FIFO will be lost). This bit is self clearing; however, a shadow bit exists that is cleared only when read by the host, thus allowing the host to monitor a FIFO reset.

Bit 0: FIFO enable. The host writes this bit to logic 1 to put the block in FIFO mode. This bit must be a 1 when writing other bits in this register or they will not be programmed. When this bit changes state, any data in the FIFOs or the RBR and THR registers will be lost and any pending interrupts are cleared.

Bit 7	Bit 6	16 Deep FIFO Trigger Levels (# of bytes) Default
0	0	1
0	1	4
1	0	8
1	1	14

LCR – Line Control

Bit 7: Divisor latch access bit. This bit allows the host, access to the divisor latch. Under normal circumstances, the bit is set to 0 (provides access to the RX and TX FIFOs at address 0). If the bit is set to 1, access to transmitter, receiver, interrupt enable, and modem control registers is disabled. In this case, when an access is made to address 0, the divisor latch least (DLL) significant byte is accessed. Address 1 accesses the most significant byte (DLM). Address 7 accesses the DLX divisor latch register. Address 4 accesses the MCX status/control register.

Bit 6: Used to denote a host-generated set break condition.

Bits 0,1,3,4,5: Used only in parity bit generation for the 7 bit data byte case. Bits 0 and 1 are used for word length select (b0 = 0 and b1 = 1 is used for 7 bit data). Bit 3 is parity enable. Bit 4 is even parity select. Bit 5 is stick parity.

MCR – Modem Control

- Bits 5–7:** Reserved, and will always be 0.
- Bit 3:** Controls the signal used to 3-state the host interrupt. If 0, then an active-low L33xV output will be set to 0, and this signal will be used to 3-state the host interrupt output pin.
- Bits 0–2:** Reserved.
- Bit 2:** OUT1.
- Bit 1:** Request to Send (RTS).
- Bit 0:** Data terminal ready (DTR).

LSR – Line Status

- Bit 7:** Error in RX FIFO. This bit is always set to 1 if at least one data byte in the RX FIFO has an error. This will clear when there are no more errors in the RX FIFO.
- Bit 6:** Transmitter empty. This bit is the same as LSR bit 5 (THRE) in MMM
- Bit 5:** Transmitter holding register empty. This bit is set to 1 when either the transmitter holding register has been read (emptied) by the micro-controller (16450 mode) or the TX FIFO is empty (16550 mode). This bit is set to 0 when either the THR or the TX FIFO becomes not empty in 16450 mode. In 16550 mode, it is set to 0 only after the trigger level has been met since the last occurrence of TX FIFO empty. If the transmitter timer is enabled, a shadow bit exists which delays the timer setting this bit to 1. When reading this bit, the micro-controller will not see the delay. Both shadow and register bits are cleared when the host writes to the THR or TX FIFO in 16450 mode. The trigger level must be reached to clear the bit in 16550 (FIFO) mode.
- Bits 2–4:** Used for parity error, framing error, and break detect. These bits are written, indirectly, by the micro-controller as follows: The bits are first written to the shadow bit locations when the micro-controller write accesses the LSR. When the next character is written to the receive buffer (RBR) or the RX FIFO, the data in the shadow bits is then copied to the RBR (16450 mode) or RX FIFO (16550 mode). In FIFO mode, bits become available to the host when the data byte associated with the bits is next to be read. In FIFO mode, with successive reads of the receiver, the status bits will be set if an error occurs on any byte. Once the micro-controller writes to the RBR or RX FIFO, the shadow bits are auto cleared. The register bits are updated with each host read.
- Bit 1:** Overrun error. This bit is set if the micro-controller makes a second write to RBR before the host reads data in the buffer (16450 mode) or with a full RX FIFO (16550 mode). No data will be transferred to the RX FIFO under these circumstances. This bit is reset when the host reads the LSR.
- Bit 0:** Data ready bit. This bit is set to 1 when received data is available, either in the RX FIFO (16550 mode) or the RBR (16450 mode). This bit is set immediately upon the micro-controller writing data to the RBR or FIFO if the receive timer is not enabled, but it is delayed by the timer interval if the receive timer is enabled. For micro-controller read access, a shadow bit exists so that the micro-controller does not see the delay that the host sees. Both bits are cleared to logic 0 immediately upon reading all data in either RBR or RX FIFO.

MSR – Modem Status

Bits 4 through 7 of the MSR can also take on the MCR bits 0 through 3 value when in MCR loop mode (i.e. when MCR b4 = 1). The transfer of bits in loop back has a null modem twist (i.e. MCR b0 goes to MSR b5 and MCR b1 goes to MSR b4).

- Bit 7:** Data carrier detect (DCD) bit.
- Bit 6:** Ring indicator (RI) bit.
- Bit 5:** Data set ready (DSR) bit.
- Bit 4:** Clear to send (CTS) bit.
- Bit 3:** Delta data carrier detect pin. This bit is set to a 1 whenever the data carrier detect bit changes state. It is reset when the host reads the modem status register.
- Bit 2:** Trailing edge ring indicator bit. This bit is set to 1 on the falling edge of the ring indicator bit. It is reset when the host reads the modem status register.
- Bit 1:** Delta data set ready bit. This bit is set to 1 whenever the data set ready changes state. It is reset when the host reads the modem status register.
- Bit 0:** Delta clear to send bit. This bit is a one whenever the clear to send bit changes state. It is reset when the host reads the modem status register.

SCR – Scratch

The host programmer uses this register for temporary data storage.

DLL – Divisor Latch (LSByte)

This register contains low-order byte for the 16-bit clock divider. It is kept to maintain register set compatibility with the 16C550A interface. However, it is not used for clock generation since MMM does not require the generation of a real baud clock.

DLM – Divisor Latch (MSByte)

This register contains high-order byte for the 16-bit clock divider. It is kept to maintain register set compatibility with the 16C550A interface. However, it is not used for clock generation, since MMM does not require the generation of a real baud clock.

Programming the Baud Rate Generator Registers DLM (MSB) and DLL (LSB) provides a user capability for selecting the desired final baud rate. The example in the Table below shows the selectable baud rates available when using a 1.8432 MHz external clock input.

Baud Rate Generator Programming Table

Baud Rate	16 x Clock Divisor (Decimal)	DLM Value (HEX)	DLL Value (HEX)
110	1047	04	17
300	384	01	80
600	192	00	C0
1200	96	00	60
2400	48	00	30
4800	24	00	18
9600	12	00	0C
19.2K	6	00	06
38.4K	3	00	03
57.6K	2	00	02
115.2K	1	00	01

Application Notes

Tip and Ring Interface

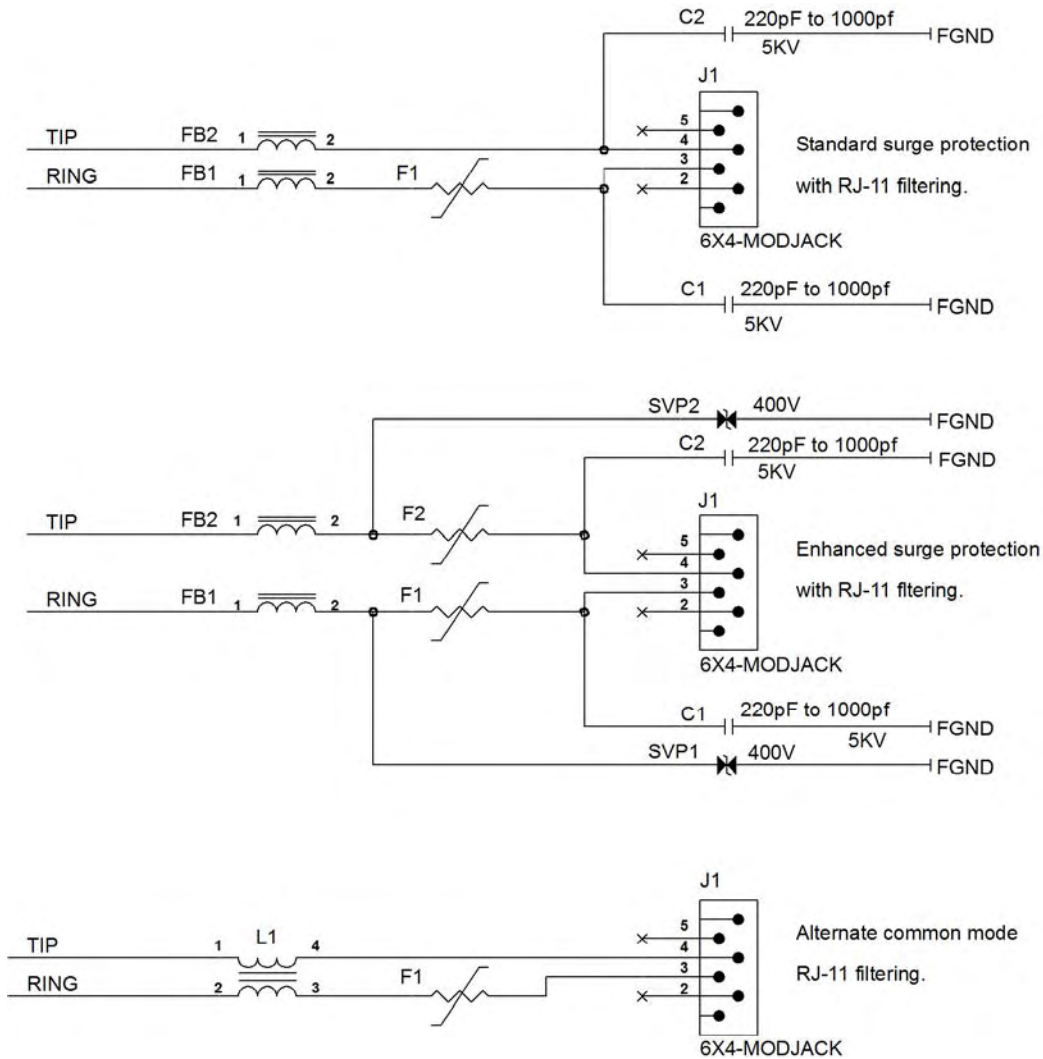

OEM Motherboard Filtering and Surge Protection Options

See *Design Considerations and Recommended Parts* in Chapter 1.

Recommended Uses for Filtering Options

- Enhanced Surge Protection with RJ-11 Filtering**
 Use this option when additional lightning protection may be needed.
- Alternate Common Mode with RJ-11 Filtering**
 Use this option when your design has common mode emission issues.

Chapter 8 – SocketModem® (MT5692SMI)

Introduction

This chapter covers the SocketModem® MT5692SMI and its various builds: serial, parallel, voice. The serial build option can be ordered with or without IP functionality.

The Multi-Tech SocketModem creates communication-ready devices by integrating data/fax/voice functionality into a single product design. The SocketModem is a space-efficient (1" x 2.5"), embedded modem that provides V.92 or V.34/33.6K data communication. The complete, ready-to-integrate modem dramatically reduces development time and costs for system designers.

The MT5692SMI SocketModem is a standard 64-pin modem used for integrating data communications.

- It is a single-port modem that integrates the controller, DSP, and DAA in a 1" x 2.5" form factor and communicates to a host controller via an asynchronous serial interface.
- It is available with an 8-bit parallel interface.

The SocketModem IP, MT5692SMI-IP, embedded modem creates Internet-ready devices by integrating modem functionality and a complete TCP/IP protocol stack into a single, universal socket design. This embedded modem sends and receives data via e-mail, HTTP, or socket interfaces. It also complies with telecom requirements globally allowing for worldwide shipments.

Product Build Options and Ordering Information

Product	Description	Region	Order this Product ✓
MT5692SMI			
Serial Builds			
MT5692SMI-34	V.34 Serial Data / V.17 Fax, 5V	Global	
MT5692SMI-L-34	V.34 Serial Data / V.17 Fax, 3.3V	Global	
MT5692SMI-92	V.92 Serial Data / V.17 Fax, 5V	Global	
MT5692SMI-L-92	V.92 Serial Data / V.17 Fax, 3.3V	Global	
MT5692SMI-X-L-92	V.92 Serial Data / V.17 Fax, 3.3V (excludes LED pins)	Global	
IP Builds			
MT5692SMI-IP-92	V.92 Serial Data-Only 5V	Global	
MT5692SMI-IP-L-92	V.92 Serial Data-Only, 3.3V	Global	
Voice Builds			
MT5692SMI-V-34	V.34 Serial Data / V.17 Fax / Voice, 5V	Global	
MT5692SMI-V-92	V.92 Serial Data / V.17 Fax / Voice, 5V	Global	
Parallel Builds			
MT5692SMI-P-34	V.34 Parallel Data / V.17 Fax, 5V	Global	
MT5692SMI-P-L-34	V.34 Parallel Data / V.17, 3.3V	Global	
MT5692SMI-P-92	V.92 Parallel Data / V.17 Fax, 5V	Global	
MT5692SMI-P-L-92	V.92 Parallel Data / V.17 Fax, 3.3V	Global	
Developer Kits			
MTSMI-UDK	SocketModem Serial Developer Kit	Global	
MTSMI-P-UDK	SocketModem Parallel Developer Kit	Global	

How to Read the Product Codes in the Above Table:

34	V.34 data rate
92	V.92/56K data rate
L	3.3V power input (default is 5V)
P	Parallel interface (default is serial)
V	Voice (Microphone and Speaker)
X	Excludes LED pins
IP	Universal IP™ Stack
UDK	Universal Developer Kit

Other Product Codes:

The complete product code may end in **.Rx**. For example, MT5692SMI-V-34.Rx. "R" indicates product revision. "x" is the revision number.

AT Commands Reference Guide

Product	Reference Guides Title and Document Product Number	Fax Commands	Voice Commands
SocketModem (MT5692SMI)	MT5692SMI AT Commands Reference Guide (S000468x)	Included in S000468x	Included in S000468x
SocketModem (MT5692SMI-IP)	Universal IP AT Commands Reference Guide (S000457x)	NA	NA

Technical Specifications

The MT5692SMI SocketModems meet the following specifications:

Category	Description
Data Standards	V.92, V.34, V.32bis, V.32, V.23, V.23 half-duplex, V.23 reverse, V.22bis, V.22bis Fast Connect, V.22, V.21, Bell 212A/Bell 103, V.29 FastPOS, V.80 Synchronous Access Mode (V.80 not for IP build)
Data Format	All Builds: Serial, asynchronous Parallel Build: 8-bit parallel interface
Character Format	10 bit
Serial/Data Speeds	All Builds Except IP: Supports DTE speeds up to 230.4K bps, autobaud up to 115.2K bps For IP Build: Supports DTE speeds up to 921.6K bps,
Client-to-Client Data Rates	33600, 31200, 28800, 26400, 24000, 21600, 19200, 16800, 14400, 12000, 9600, 7200, 4800, 2400, 1200, 0-300 bps
Data Error Correction	V.42 LAPM and MNP 2-4
Data Compression	V.44, V.42bis, MNP 5
Fax Compatibility	All Builds Except IP: V.17, V.29, V.27ter, V.21 channel 2
Fax Class	All Builds Except IP: Class 1, Class 1.0
Modes of Operation	Full duplex over dial-up lines; data mode, command mode, online command mode
Size	2.54" (64.541 mm) x 1.045" (26.543 mm)
Weight	0.6 oz. (0.017 kg.)
Operating Temperature	-40° to +85° C
Storage Temperature	-40° to +85° C
Humidity	20% to 90% (non-condensing)
Operating Voltage	3.3V or 5V Note: Voice modules are available with 5V only
Transmit Level	-12 dBm (varies by country)
Receiver Sensitivity	-43 dBm under worst-case conditions
DAA Isolation	1.5Kv r.m.s. or 2121 VDC at working voltage of 250VAC
Flow Control	All Builds Except IP: XON/XOFF (software), RTS/CTS (hardware)
Command Buffer	60 characters
Telephony/TAM	All Builds Except Voice: V.253 commands 8 kHz sample rate Concurrent DTMF, distinctive ring, and "Bell Core Type 1" Caller ID 8-bit μ -law and A-law PCM coding Supports PCM Encoding: 2-bit and 4-bit ADPCM, 8-bit and 16-bit linear PCM, and 4-bit IMA coding Voice Build: Voice build has a microphone for speakerphone function
Internet Protocols	For IP Build Only: Internet Protocols Supported: Dial-in PPP, DNS, FTP, ICMP, IP, LCP, PPP, SMTP, SNTP, TCP, UDP Socket Authentication Protocols: CHAP, Dial-up Script, PAP
Compliance	EMC Compliance FCC Part 15 (Class B) ICES-003 (Class B) EN 55022 (Class B) EN 55024 Safety Compliance UL 60950-1 cUL 60950-1 EN 60950-1 AS/NZS 60950:2000 Telecom Compliance 47 CFR Part 68 CS-03 R&TTE A-Tick (Other countries included per the Modem Globalization Guide)
Warranty	2 years

Mechanical Drawings – Basic Builds

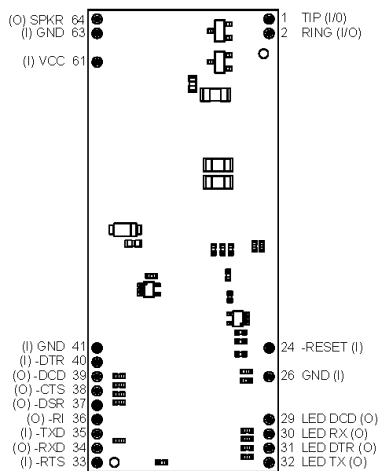

MT5692SMI-34
MT5692SMI-L-34
MT5692SMI-92
MT5692SMI-L-92

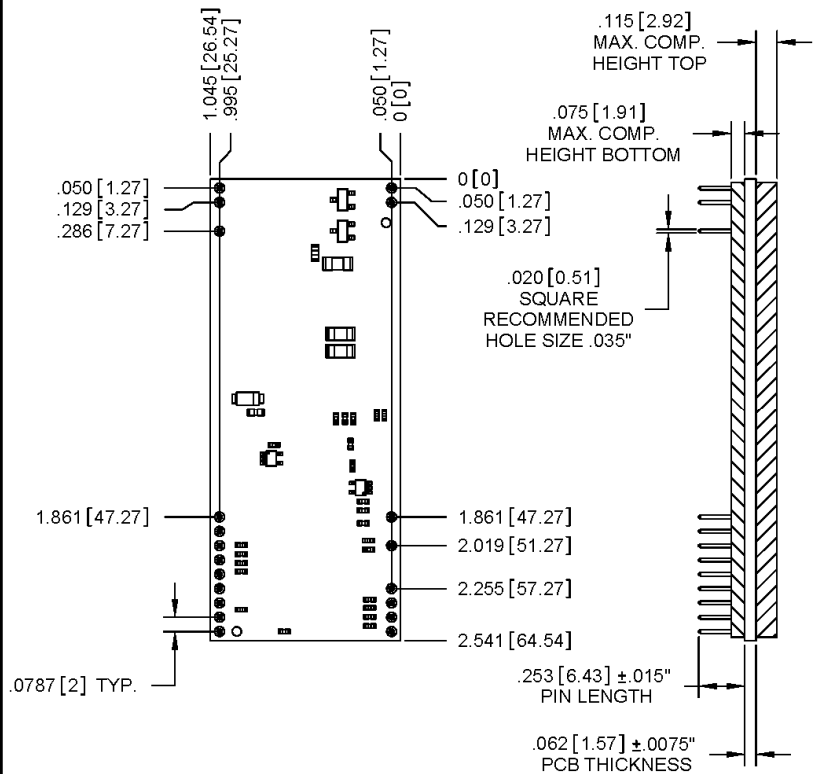
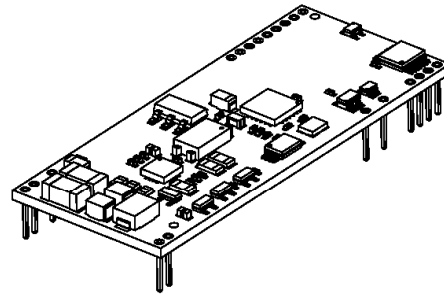

Mechanical Drawings – IP Builds

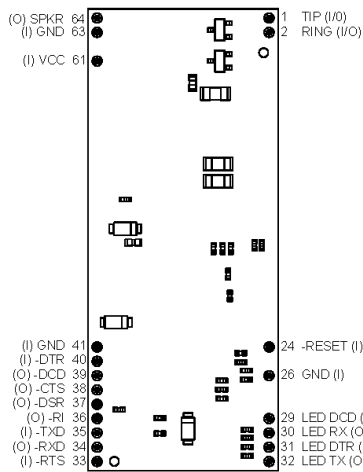
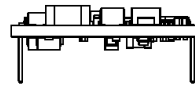
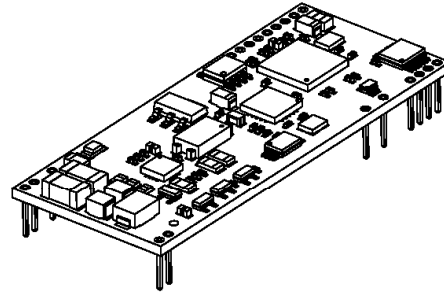

MT5692SMI-IP-92
MT5692SMI-IP-L-92

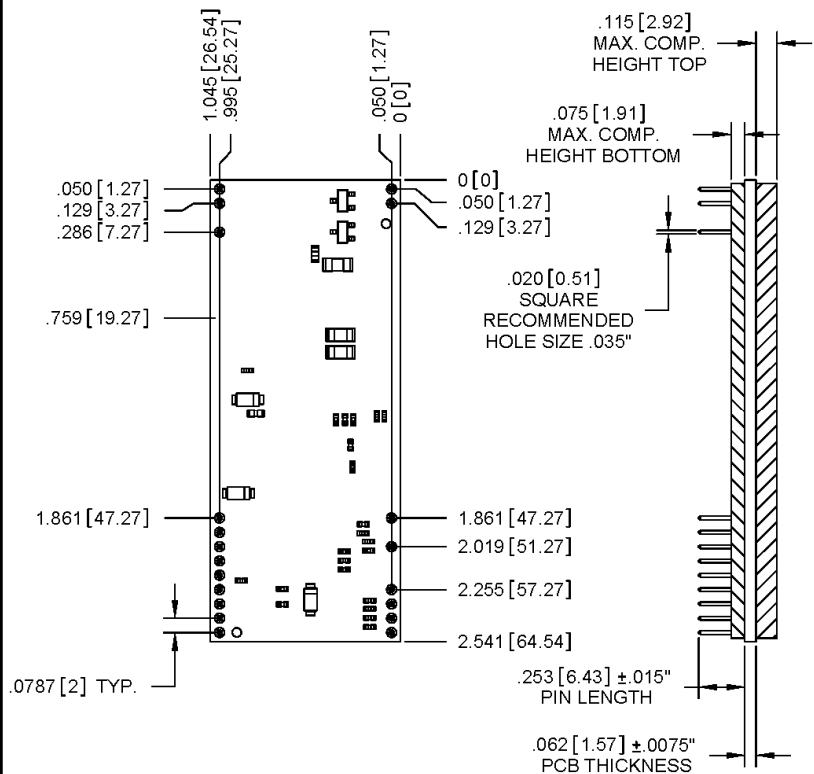

DIMENSIONS IN In [mm]

Mechanical Drawings – No LEDS 3.3V Builds

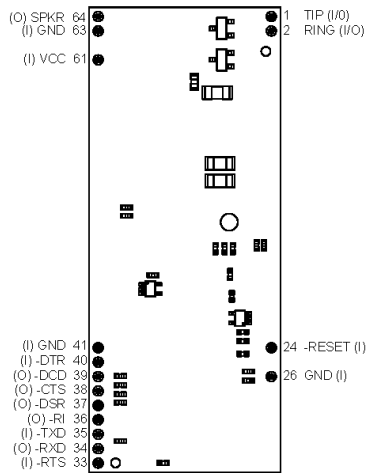

MT5692SMI-X-L-92

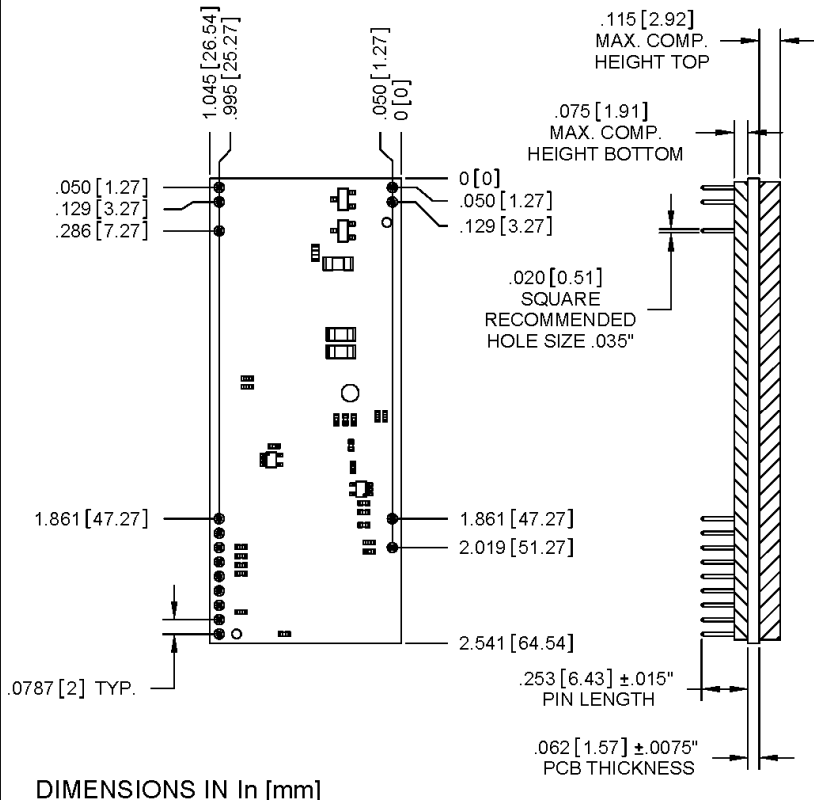
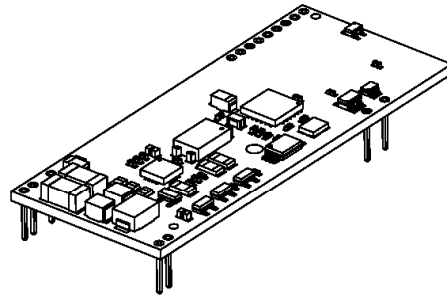

Mechanical Drawings – Voice Builds

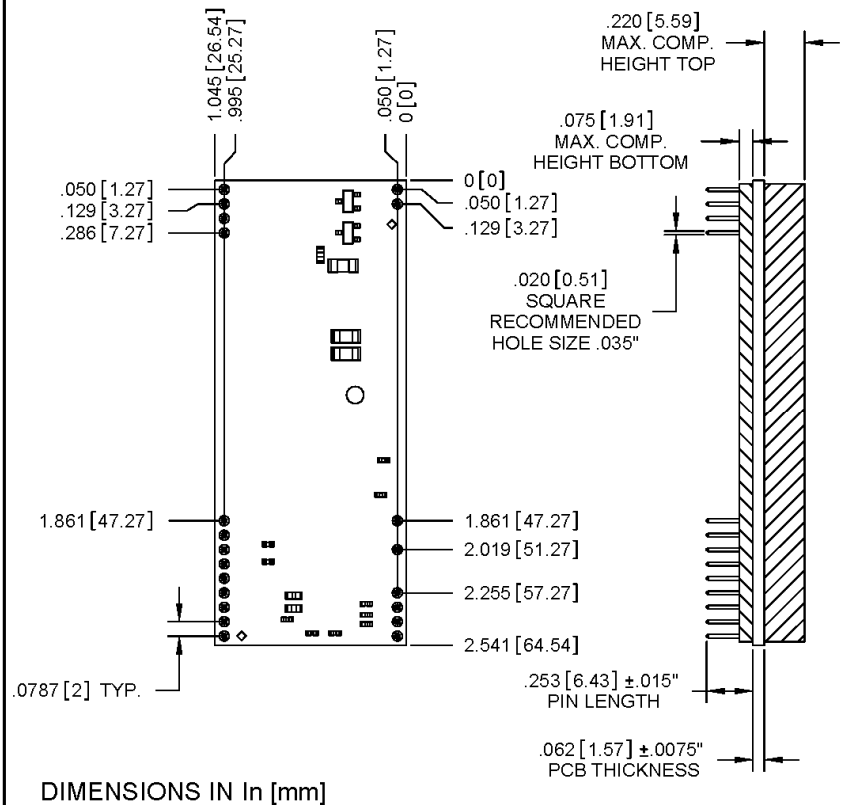
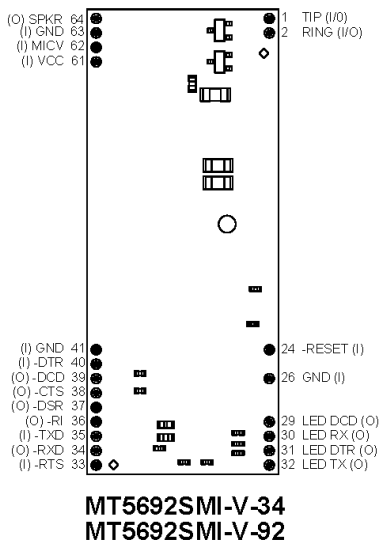
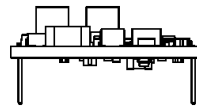
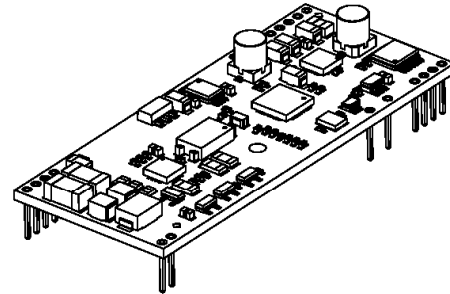

Mechanical Drawings – Parallel Builds

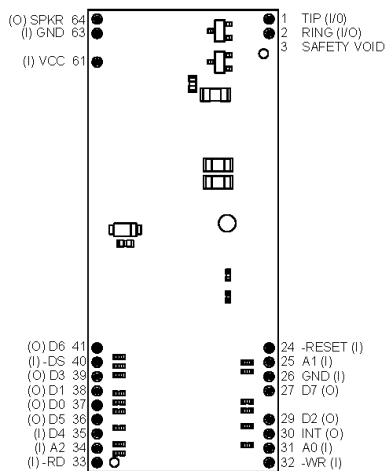
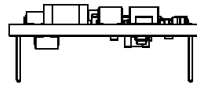
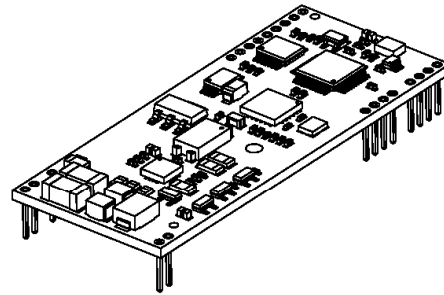

MT5692SMI-P-34
 MT5692SMI-P-L-34
 MT5692SMI-P-92
 MT5692SMI-P-L-92

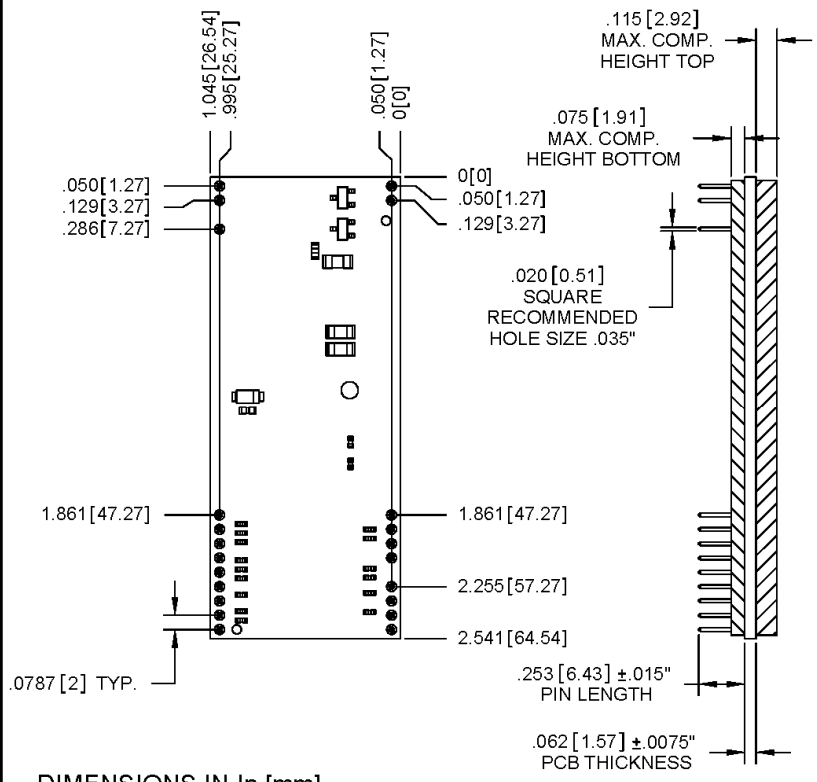

Operating Conditions

Parameter	Minimum	Maximum
5V Supply Range – Vcc	4.5V	5.5V
3.3V Supply Range – Vcc	3.135V	3.465V

Absolute Maximum Rating

Parameter	Minimum	Maximum
Voltage at Any Signal Pin	GND -0.3V	Vcc +3.3V

DC Electrical Characteristics

5V SocketModem

5VDC Characteristics (VDD = 5V ± 0.25V) VDDMAX = 5.25V

Parameter	Minimum	Maximum
Input Low Level –DS (40)	-0.3V	0.8V
Input High Level A0 (31), A1 (25), –WR (32), –RD (33)	2.2V	Vcc
Output Low Level DO (37), D1 (38), D2 (29), D3 (39), D4 (35), D5 (36), D6 (41), D7 (27)	NA	0.4V
Output High Level INT (30)	2.4V	NA
Digital Input Capacitance – 50pF		

3.3 V SocketModem

3.3VDC Characteristics (VDD = 3.3V ± 0.3V) VDDMAX = 3.6V

Parameter	Minimum	Maximum
Input Low Level –DS (40)	-0.3V	0.8V
Input High Level A0 (31), A1 (25), A2 (34), –WR (32), –RD (33)	2V	Vcc
Output Low Level DO (37), D1 (38), D2 (29), D3 (39), D4 (35), D5 (36), D6 (41), D7 (27) 2 mA, Z _{INT} = 120 Ω	NA	0.4V
Output High Level INT (30) 2 mA, Z _{INT} = 120 Ω	2V	NA
Digital Input Capacitance – 50pF		

Power Measurements

MT5692SMI (Serial Build) Power Measurements* at 3.3V and 5V

Input Voltage: 3.3V			
	Sleep Mode	Typical	Maximum
Current (AMPS)	0.014	0.069	0.080
Watts	0.046	0.216	0.249

Input Voltage: 5V			
	Sleep Mode	Typical	Maximum
Current (AMPS)	0.018	0.074	0.088
Watts	0.089	0.359	0.425

MT5692SMI-IP (IP Build) Power Measurements* at 3.3V and 5V

Input Voltage: 3.3V			
	Sleep Mode	Typical	Maximum
Current (AMPS)	0.047	0.101	0.112
Watts	0.151	0.316	0.349

Input Voltage: 5V			
	Sleep Mode	Typical	Maximum
Current (AMPS)	0.052	0.109	0.121
Watts	0.256	0.528	0.583

MT5692SMI –V (Voice Build) Power Measurements* at 5V

Note: The voice build is not available in 3.3V.

Input Voltage: 5V			
	Sleep Mode	Typical	Maximum
Current (AMPS)	0.016	0.076	0.089
Watts	0.080	0.380	0.445

MT5692SMI-P (Parallel Build) Power Measurements* at 3.3V and 5V

Input Voltage: 3.3V			
	Sleep Mode	Typical	Maximum
Measured Voltage	3.30	3.29	3.29
Current (AMPS)	0.015	0.072	0.081
Watts	0.051	0.236	0.267

Input Voltage: 5V			
	Sleep Mode	Typical	Maximum
Measured Voltage	4.91	4.86	4.84
Current (AMPS) with 5V	0.014	0.069	0.079
Watts	0.068	0.334	0.380

***Note:** Multi-Tech Systems, Inc. recommends that the customer incorporate a 10% buffer into their power source when determining product load.

Parallel Host Bus Timing Table

Symbol	Parameter	Min	Max	Units
READ (See Notes)				
^t AS	Address Setup	5	-	ns
^t AH	Address Hold	5	-	ns
^t CS	Chip Select Setup	5	-	ns
^t CH	Chip Select Hold	0	-	ns
^t RD	RD Strobe Width	77	-	ns
^t DD	Read Data Delay	10	25	ns
^t DRH	Read Data Hold	5	-	ns
WRITE (See Notes)				
^t AS	Address Setup	5	-	ns
^t AH	Address Hold	5	-	ns
^t CS	Chip Select Setup	0	-	ns
^t CH	Chip Select Hold	10	-	ns
^t WT	WT Strobe Width	15	-	ns
^t DS	Write Data Setup (see Note 4)	15	20	ns
^t DWH	Write Data Hold (see Note 5)	5	-	ns
Notes:				
1. When the host executes consecutive Rx FIFO reads, a minimum delay of 2 times the internal CPU clock cycle plus 15 ns (85.86 ns at 28.224 MHz) is required from the falling edge of RD to the falling edge of the next Host Rx FIFO RD clock.				
2. When the host executes consecutive Tx FIFO writes, a minimum delay of 2 times the internal CPU clock cycle plus 15 ns (85.86 ns at 28.224 MHz) is required from the falling edge of WT to the falling edge of the next Host Tx FIFO WT clock.				
3. $t_{RD}, t_{WT} = t_{CYC} + 15 \text{ ns}$.				
4. ^t DS is measured from the point at which both CS and WT are active.				
5. ^t DWH is measured from the point at which either CS and WT become active.				
6. Clock Frequency = 1.8432 MHz clock.				

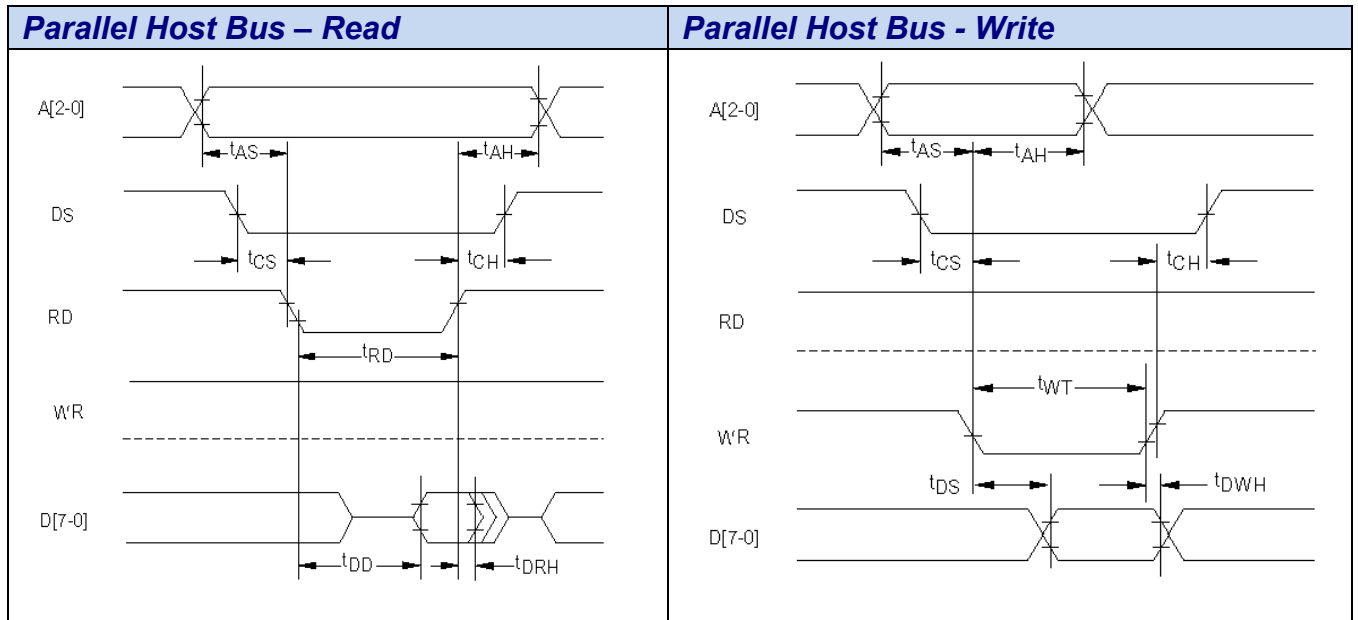

Pin Descriptions for a Parallel SocketModem Device

Pin #	Signal	I/O	Description								
1	Tip	I/O	Tip Signal from Telco. Tip connection to the phone line (RJ-11 Pin 4). The SocketModem is Tip/Ring polarity insensitive.								
2	Ring	I/O	Ring Signal from Telco. Ring connection to the phone line (RJ-11 Pin 3). The SocketModem is Tip/Ring polarity insensitive.								
24	–RESET	I	<p>Device Reset (with pull-up). The active low –RESET input resets the device logic and returns the configuration of the device to the original factory default values or "stored values" in the NVRAM. –RESET is tied to VCC through a time-constant circuit for "Power-on-Reset" functionality. The SocketModem is ready to accept commands after a fixed amount of time ("X" Time) after power-on or reset.</p> <table border="1"> <thead> <tr> <th>Model</th> <th>Time Constant</th> <th>"X" Time</th> <th>Minimum Reset Pulse*</th> </tr> </thead> <tbody> <tr> <td>MT5692SMI</td> <td>250 ms</td> <td>6 seconds</td> <td>100us</td> </tr> </tbody> </table> <p>*The SocketModem device may respond to a shorter reset pulse.</p> <p>Reset Line Interface for the MT5692SMI. The modem's reset line employs a 10K pull up resistor. If an open collector driver is to be used, run that output to the modem only and use a separate driver for other embedded components. The modem's reset signal may also be driven by a circuit that both sinks and sources current if desired. It is also important to note that these modems do not require an external reset. They have their own internal reset circuitry and voltage monitor and will function correctly even if the reset input is open.</p> <p>Modem Reset (with weak pull-up). The active low –RESET input resets the SocketModem logic and returns the AT command set to the original factory default values or to "stored values" in NVRAM. The modem is ready to accept commands within 6.5 seconds of power-on or reset. Reset must be asserted for a minimum of 300 ns.</p>	Model	Time Constant	"X" Time	Minimum Reset Pulse*	MT5692SMI	250 ms	6 seconds	100us
Model	Time Constant	"X" Time	Minimum Reset Pulse*								
MT5692SMI	250 ms	6 seconds	100us								
25	A0	I	Host Bus Address Line 0. During a host read or write operation, A0 selects an internal 16C450 or 16C550-compatible register. The state of the divisor latch access bit (DLAB) affects the selection of certain registers.								
26	DGND	GND	Digital Ground								
30	INT	O	Host Bus Interrupt. INT output is set high when the receiver error flag, receiver data available, transmitter holding register empty, or modem status interrupt have an active high condition. INT is reset low upon the appropriate interrupt service or master reset operation.								
31	A1	I	Host Bus Address Line 1. During a host read or write operation, A1 selects an internal 16C450 or 16C550-compatible register. The state of the divisor latch access bit (DLAB) affects the selection of certain registers.								
32	–WR	I	Host Bus Write. –WR is an active low, write control input. When –DS is low, –WR low allows the host to write data or control words into a selected modem register.								
33	–RD	I	Host Bus Read. –RD is an active low, read control input. When –DS is low, –RD low allows the host to read status information or data from a selected modem register.								
34	A2	I	Host Bus Address Line 2. During a host read or write operation, A2 selects an internal 16C450 or 16C550-compatible register. The state of the divisor latch access bit (DLAB) affects the selection of certain registers.								
40	–DS	I	Host Bus Device Select. –DS input low enables the modem for read or write.								
61	VCC	PWR	+5V or 3.3V Supply (depends upon model).								
63	AGND	GND	Analog Ground. This is tied common with DGND on the SocketModem. To minimize potential ground noise issues, connect audio circuit return to AGND.								
64	SPKR	O	<p>Speaker. Dual purpose output for call progress signals or speakerphone functions.</p> <p>Call Progress signaling on MT5692SMI is a square wave output that can be optionally connected to a low-cost single-ended speaker; e.g., a sounducer or an analog speaker circuit.</p> <p>Speakerphone Output on the MT5692SMI is under the control of +FCLASS. This is a single-ended analog output. SPKR is tied directly to the CODEC. One side of a differential AC output coupled through a 6.8K ohm resistor and capacitor.</p>								

SocketModem Parallel Interface

The modem supports a 16550A interface in parallel interface versions. The 16550A interface can operate in FIFO mode or non-FIFO mode. Non-FIFO mode is the same as the 16450-interface operation. FIFO mode's unique operations are described in this chapter.

Overview

The modem emulates the 16450/16550A interface and includes both a 16-byte receiver data first-in first-out buffer (RX FIFO) and a 16-byte transmit data first-in first-out buffer (TX FIFO).

FIFO Mode Selected

When FIFO mode is selected in the FIFO Control Register (FCR0 = 1), both FIFOs are operative.

FIFO Mode Not Selected

When FIFO mode is not selected, operation is restricted to a 16450-interface operation.

Receive Data

Received Data is read by the host from the Receiver Buffer (RX Buffer). The RX Buffer corresponds to the Receiver Buffer Register in a 16550A device. In FIFO mode, the RX FIFO operates transparently behind the RX Buffer. Interface operation is described with reference to the RX Buffer in FIFO and non-FIFO modes.

Transmit Data

Transmit Data is loaded by the host into the Transmit Buffer (TX Buffer). The TX Buffer corresponds to the Transmit Holding Register in a 16550A device. In FIFO mode, the TX FIFO operates transparently behind the TX Buffer. Interface operation is described with reference to the TX Buffer in both FIFO and non-FIFO modes.

Receiver FIFO Interrupt Operation

Receiver Data Available Interrupt

When the FIFO mode is enabled (FCR0 = 1) and receiver interrupt (RX Data Available) is enabled (IER0 = 1), receiver interrupt operation is as follows:

1. The Receiver Data Available Flag (LSR0) is set as soon as a received data character is available in the RX FIFO. LSR0 is cleared when RX FIFO is empty.
2. The Receiver Data Available Interrupt code (IIR0-IIR4 = 4h) is set whenever the number of received data bytes in the RX FIFO reaches the trigger level specified by FCR6-FCR7 bits. It is cleared whenever the number of received data bytes in the RX FIFO drops below the trigger level specified by FCR6-FCR7 bits.
3. The HINT interrupt is asserted whenever the number of received data bytes in the RX FIFO reaches the trigger level specified by FCR6-FCR7 bits. HINT interrupt is de-asserted when the number of received data bytes in the RX FIFO drops below the trigger level specified by FCR6-FCR7 bits.

Receiver Character Timeout Interrupts

When the FIFO mode is enabled (FCR0 = 1) and receiver interrupt (Receiver Data Available) is enabled (IER0 = 1), receiver character timeout interrupt operation is as follows:

1. A Receiver character timeout interrupt code (IIR0-IIR3 = Ch) is set if at least one received character is in the RX FIFO, the most recent received serial character was longer than four continuous character times ago (if 2 stop bits are specified, the second stop bit is included in this time period), and the most recent host read of the RX FIFO was longer than four continuous character times ago.

Transmitter FIFO Interrupt Operation

Transmitter Empty Interrupt

When the FIFO mode is enabled (FCR0 = 1) and transmitter interrupt (TX Buffer Empty) is enabled (IER0 = 1), transmitter interrupt operation is as follows:

1. The TX Buffer Empty interrupt code (IIR0-IIR3 = 2h) will occur when the TX Buffer is empty. It is cleared when the TX Buffer is written to (1 to 16 characters) or the IIR is read.
2. The TX Buffer Empty indications will be delayed 1 character time minus the last stop bit time whenever the following occur: THRE = 1 and there have not been at least two bytes at the same time in the TX FIFO Buffer since the last setting of THRE was set. The first transmitter interrupt after setting FCR0 will be immediate.

Register Functional Definitions

The following table delineates the assigned bit functions for the twelve internal registers. The assigned bit functions are more fully defined in the following paragraphs.

Internal Registers

Register No.	Register Name	BIT No.							
		7	6	5	4	3	2	1	0
7	Scratch Register (SCR)	Scratch Register							
6	Modem Status Register (MSR)	Data Carrier Detect (DCD)	Ring Indicator (RI)	Data Set Ready (DSR)	Clear to Send (CTS)	Delta Data Carrier Detect (DDCD)	Trailing Edge of Ring Indicator (TERI)	Delta Data Set Ready (DDSR)	Delta Clear to Send (DCTS)
5	Line Status Register (LSR)	RX FIFO Error	Transmitter Empty (TEMT)	Transmitter Buffer Register Empty (THRE)	Break Interrupt (BI)	Framing Error (FE)	Parity Error (PE)	Overrun Error (OE)	Receiver Data Ready (DR)
4	Modem Control Register (MCR)	0	0	0	0	Out 2	Out 1	Request to Send (RTS)	Data Terminal Ready (DTR)
3	Line Control Register (LCR)	Divisor Latch Access Bit (DLAB)	Set Break	Stick Parity	Even Parity Select (EPS)	Parity Enable (PEN)	Number of Stop Bits (STB)	Word Length Select Bit 1 (WLS1)	Word Length Select Bit 0 (WLS0)
2	Interrupt Identify Register (IIR) (Read Only)	FIFOs Enabled	FIFOs Enabled	0	0	Pending Interrupt ID Bit 2	Pending Interrupt ID Bit 1	Pending Interrupt ID Bit 0	"0" if Interrupt Pending
2	FIFO Control Register (FCR) (Write Only)	Receiver Trigger MSB	Receiver Trigger LSB	Reserved	Reserved	0	TX FIFO Reset	RX FIFO Reset	FIFO Enable
1 (DLAB = 0)	Interrupt Enable Register (IER)	0	0	0	0	Enable Modem Status Interrupt (EDSSI)	Enable Receiver Line Status Interrupt (ELSI)	Enable Transmitter Holding Register Empty Interrupt (ETBEI)	Enable Received Data Available Interrupt (ERBFI)
0 (DLAB = 0)	Transmitter Buffer Register (THR)	Transmitter FIFO Buffer Register (Write Only)							
0 (DLAB = 0)	Receiver Buffer Register (RBR)	Receiver FIFO Buffer Register (Read Only)							
1 (DLAB = 1)	Divisor Latch MSB Register (DLM)	Divisor Latch MSB							
0 (DLAB = 1)	Divisor Latch LSB Register (DLL)	Divisor Latch LSB							

IER – Interrupt Enable Register

(Addr = 1, DLAB = 0)

The IER enables five types of interrupts that can separately assert the HINT output signal (See the Interrupt Sources and Reset Control table in the IIR section of this chapter). A selected interrupt can be enabled by setting the corresponding enable bit to a 1, or disabled by setting the corresponding enable bit to a 0. Disabling an interrupt in the IER prohibits setting the corresponding indication in the IIR and assertion of HINT. Disabling all interrupts (resetting IER0 – IER3 to a 0) inhibits setting of any Interrupt Identifier Register (IIR) bits and inhibits assertion of the HINT output. All other system functions operate normally, including the setting of the Line Status Register (LSR) and the Modem Status Register (MSR).

The IER enables five types of interrupts that can separately assert the HINT output signal. A selected interrupt can be enabled by setting the corresponding enable bit to a 1, or disabled by setting the corresponding enable bit to a 0. Disabling an interrupt in the IER prohibits setting the corresponding indication in the IIR and assertion of HINT. Disabling all interrupts (resetting IER0 - IER3 to a 0) inhibits setting of any Interrupt Identifier Register (IIR) bits and inhibits assertion of the HINT output. All other system functions operate normally, including the setting of the Line Status Register (LSR) and the Modem Status Register (MSR).

Bits 7-4 Not used.

Always 0.

Bit 3 Enable Modem Status Interrupt (EDSSI).

This bit, when a 1, enables assertion of the HINT output whenever the Delta CTS (MSR0), Delta DSR (MSR1), Delta TER (MSR2), or Delta DCD (MSR3) bit in the Modem Status Register (MSR) is a 1. This bit, when a 0, disables assertion of HINT due to setting of any of these four MSR bits.

Bit 2 Enable Receiver Line Status Interrupt (ELSI).

This bit, when a 1, enables assertion of the HINT output whenever the Overrun Error (LSR1), Parity Error (LSR2), Framing Error (LSR3), or Break Interrupt (LSR4) receiver status bit in the Line Status Register (LSR) changes state. This bit, when a 0, disables assertion of HINT due to change of the receiver LSR bits 1-4.

Bit 1 Enable Transmitter Holding Register Empty Interrupt (ETBEI).

This bit, when a 1, enables assertion of the HINT output when the Transmitter Empty bit in the Line Status Register (LSR5) is a 1. This bit, when a 0, disables assertion of HINT due to LSR5.

Bit 0 Enable Receiver Data Available Interrupt (ERBFI) and Character Timeout in FIFO Mode.

This bit, when a 1, enables assertion of the HINT output when the Receiver Data Ready bit in the Line Status Register (LSR0) is a 1 or character timeout occurs in the FIFO mode. This bit, when a 0, disables assertion of HINT due to the LSR0 or character timeout.

FCR – FIFO Control Register

(Addr = 2, Write Only)

The FCR is a write-only register used to enable FIFO mode, clear the RX FIFO and TX FIFO, enable DMA mode, and set the RX FIFO trigger level.

Bits 7-6	RX FIFO Trigger Level FCR7 and FCR6 set the trigger level for the RX FIFO (Receiver Data Available) interrupt.															
	<table border="1"> <thead> <tr> <th>FCR7</th> <th>FCR6</th> <th>RX FIFO Trigger Level (Bytes)</th> </tr> </thead> <tbody> <tr> <td>0</td> <td>0</td> <td>01</td> </tr> <tr> <td>0</td> <td>1</td> <td>04</td> </tr> <tr> <td>1</td> <td>0</td> <td>08</td> </tr> <tr> <td>1</td> <td>1</td> <td>14</td> </tr> </tbody> </table>	FCR7	FCR6	RX FIFO Trigger Level (Bytes)	0	0	01	0	1	04	1	0	08	1	1	14
FCR7	FCR6	RX FIFO Trigger Level (Bytes)														
0	0	01														
0	1	04														
1	0	08														
1	1	14														
Bits 5, 4	Not used															
Bit 3	<p>DMA Mode Select – Must be set to zero. When FIFO mode is selected (FCR0 = 1), FCR3 selects non-DMA operation (FCR3 = 0) or DMA operation (FCR3 = 1). When FIFO mode is not selected (FCR0 = 0), this bit is not used (the modem operates in non-DMA mode in 16450 operation).</p> <p>DMA Operation in FIFO Mode – Not Supported</p> <p>Non-DMA Operation in FIFO Mode RXRDY will be asserted when there are one or more characters in the RX FIFO. RXRDY will go inactive when there are no more characters in the RX FIFO. TXRDY will be asserted when there are no characters in the TX FIFO. TXRDY will go inactive when the character is loaded into the TX FIFO Buffer.</p>															
Bit 2	<p>TX FIFO Reset When FCR2 is a 1, all bytes in the TX FIFO are cleared. This bit is cleared automatically by the modem.</p>															
Bit 1	<p>RX FIFO Reset When FCR1 is a 1, all bytes in the RX FIFO are cleared. This bit is cleared automatically by the modem.</p>															
Bit 0	<p>FIFO Enable When FCR0 is a 0, 16450 mode is selected and all bits are cleared in both FIFOs. When FCR0 is a 1, FIFO mode (16550A) is selected and both FIFOs are enabled. FCR0 must be a 1 when other bits in the FCR are written or they will not be acted upon.</p>															

IIR – Interrupt Identifier Register

(Addr = 2)

The Interrupt Identifier Register (IIR) identifies the existence and type of up to five prioritized pending interrupts. Four priority levels are set to assist interrupt processing in the host. The four levels, in order of decreasing priority, are Highest: Receiver Line Status, 2: Receiver Data Available or Receiver Character Timeout, 3: TX Buffer Empty, and 4: Modem Status.

When the IIR is accessed, the modem freezes all interrupts and indicates the highest priority interrupt pending to the host. Any change occurring in interrupt conditions are not indicated until this access is complete.

Bits 7-6	FIFO Mode These two bits copy FCR0.
Bits 5-4	Not Used Always 0.
Bits 3-1	Highest Priority Pending Interrupt These three bits identify the highest priority pending interrupt (Table below). Bit 3 is applicable only when FIFO mode is selected; otherwise, bit 3 is a 0.
Bit 0	Interrupt Pending When this bit is a 0, an interrupt is pending; IIR bits 1-3 can be used to determine the source of the interrupt. When this bit is a 1, an interrupt is not pending

Interrupt Sources and Reset Control Table

Interrupt Identification Register					Interrupt Set and Reset Functions		
Bit 3 (Note 1)	Bit 2	Bit 1	Bit 0	Priority Level	Interrupt Type	Interrupt Source	Interrupt Reset Control
0	0	0	1	—	None	None	—
0	1	1	0	Highest	Receiver Line Status	Overrun Error (OE) (LSR1), Parity Error (PE) (LSR2), Framing Error (FE) (LSR3), or Break Interrupt (BI) (LSR4)	Reading the LSR
0	1	0	0	2	Received Data Available	Received Data Available (LSR0) or RX FIFO Trigger Level (FCR6-FCR7) Reached ¹	Reading the RX Buffer or the RX FIFO drops below the Trigger Level
1	1	0	0	2	Character Timeout Indication ¹	The RX FIFO contains at least 1 character and no characters have been removed from or input to the RX FIFO during the last 4 character times.	Reading the RX Buffer
0	0	1	0	3	TX Buffer Empty	TX Buffer Empty	Reading the IIR or writing to the TX Buffer
0	0	0	0	4	Modem Status	Delta CTS (DCTS) (MSR0), Delta DSR (DDST) (MSR1), Trailing Edge Ring Indicator (TERI) (MSR3), or Delta DCD (DCD) (MSR4)	Reading the MSR
Note: 1. FIFO Mode only.							

LCR – Line Control Register

(Addr = 3)

The Line Control Register (LCR) specifies the format of the asynchronous data communications exchange.

Bit 7	Divisor Latch Access Bit (DLAB) This bit must be set to a 1 to access the Divisor Latch Registers during a read or write operation. It must be reset to a 0 to access the Receiver Buffer, the Transmitter Buffer, or the Interrupt Enable Register.
Bit 6	Set Break When bit 6 is a 1, the Transmit data is forced to the break condition, i.e., space (0) is sent. When bit 6 is a 0, break is not sent. The Set Break bit acts only on the Transmit data and has no effect on the serial in logic.
Bit 5	Stick Parity When Parity is enabled (LCR3 = 1) and stick parity is selected (LCR5 = 1), the parity bit is transmitted and checked by the receiver as a 0 if even parity is selected (LCR4 = 1) or a 1 if odd parity is selected (LCR4 = 0). When the stick parity is not selected (LCR3 = 0), parity is transmit and checked as determined by the LCR3 and LCR4 bits.
Bit 4	Even Parity Select (EPS) When parity is enabled (LCR3 = 1) and stick parity is not selected (LCR5 = 0), the number of 1s transmitted or checked by the receiver in the data word bits and parity bit is either even (LCR4 = 1) or odd (LCR4 = 0).
Bit 3	Enable Parity (PEN) When bit 3 is a 1, a parity bit is generated in the serial out (transmit) data stream and checked in the serial in (receive) data stream as determined by the LCR4 and LCR5 bits. The parity bit is located between the last data bit and the first stop bit.
Bit 2	Number of Stop GBITS (STB) This bit specifies the number of stop bits in each serial out character. If bit 2 is a 0, one stop bit is generated regardless of word length. If bit 2 is a 1 and 5-bit word length is selected, one and one-half stop bits are generated. If bit 2 is a 1 and 6-, 7-, or 8-bit word length is selected, two stop bits are generated. The serial in logic checks the first stop bit only, regardless of the number of stop bits selected.
Bit 1-0	Word Length Select (WLS0 and WLS1) These two bits specify the number of bits in each serial in or serial out character. The encoding of bits 0 and 1 is:

Bit 1	Bit 0	Word Length
0	0	5 Bits (Not supported)
0	1	6 Bits (Not supported)
1	0	7 Bits
1	1	8 Bits

MCR – Modem Control Register

(Addr = 4)

The Modem Control Register (MCR) controls the interface with modem or data set.

Bit 7-5	Not used Always 0
Bit 3	Output 2 When this bit is a 1, HINT is enabled. When this bit is a 0, HINT is in the high impedance state.
Bit 2	Output 1 Reserved.
Bit 1	Request to Send (RTS) This bit controls the Request to Send (RTS) function. When this bit is a 1, RTS is on. When this bit is a 0, RTS is off.
Bit 0	Data Terminal Ready (DTR) This bit controls the Data Terminal Ready (DTR) function. When this bit is a 1, DTR is on. When this bit is a 0, DTR is off.

LSR – Line Status Register

(Addr = 5)

This 8-bit register provides status information to the host concerning data transfer

Bit 7	RX FIFO Error In the 16450 mode, this bit is not used and is always 0. In the FIFO mode, this bit is set if there are one or more characters in the RX FIFO with parity error, framing error, or break indication detected. This bit is reset to a 0 when the host reads the LSR and note of the above conditions exist in the RX FIFO.
Bit 6	Transmitter Empty (TEMT) This bit is set to a 1 whenever the TX Buffer (THR) and equivalent of the Transmitter Shift Register (TRS) are both empty. It is reset to a 0 whenever either the THR or the equivalent of the TSR contains a character. In the FIFO mode, this bit is set to a 1 whenever the TX FIFO and the equivalent of the TSR are both empty
Bit 5	Transmitter Holding Register Empty (THRE) [TX Buffer Empty] This bit, when set, indicates that the TX Buffer is empty and the modem can accept a new character for transmission. In addition, this bit causes the modem to issue an interrupt to the host when the Transmit Holding Register Empty Interrupt Enable bit (IIR1) is set to 1. The THRE bit is set to a 1 when a character is transferred from the TX Buffer. The bit is reset to 0 when a byte is written into the TX Buffer by the host. In the FIFO mode, this bit is set when the TX FIFO is empty; it is cleared when at least one byte is in the TX FIFO.
Bit 4	Break Interrupt (BI) This bit is set to a 1 whenever the received data input is a space (logic 0) for longer than two full word lengths plus 3 bits. The BI is reset when the host reads the LSR.
Bit 3	Framing Error (FE) This bit indicates that the received character did not have a valid stop bit. The FE bit is set to a 1 whenever the stop bit following the last data bit or parity bit is detected as a logic 0 (space). The FE bit is reset to a 0 when the host reads the LSR. In the FIFO mode, the error indication is associated with the particular character in the FIFO it applies to. The FE bit set to a 1 when this character is loaded into the RX Buffer.
Bit 2	Parity Error (PE) This bit indicates that the received data character in the RX Buffer does not have the correct even or odd parity, as selected by the Even Parity Select bit (LCR4) and the Stick Parity bit (LCR5). The PE bit is reset to a 0 when the host reads the LSR. In the FIFO mode, the error indication is associated with the particular character in the FIFO it applies to. The PE bit set to a 1 when this character is loaded into the RX Buffer.
Bit 1	Overrun Error (OE) This bit is set to a 1 whenever received data is loaded into the RX Buffer before the host has read the previous data from the RX Buffer. The OE is reset to a 0 when the host reads the LSR. In the FIFO mode, if data continues to fill beyond the trigger level, an overrun condition will occur only if the RX FIFO is full and the next character has been completely received.
Bit 0	Receiver Data Ready (DR) This bit is set to a 1 whenever a complete incoming character has been received and transferred into the RX Buffer. The DR bit is reset to a 0 when the host reads the RX Buffer. In the FIFO mode, the DR bit is set when the number of received data bytes in the RX FIFO equals or exceeds the trigger level specified in the FCR0-FCR1.

MSR – Modem Status Register**(Addr = 6)**

The Modem Status Register (MSR) reports current state and change information of the modem. Bits 4-7 supply current state and bits 0-3 supply change information. The change bits are set to a 1 whenever a control input from the modem changes state from the last MSR read by the host. Bits 0-3 are reset to 0 when the host reads the MSR or upon reset.

Whenever bits 0, 1, 2, or 3 are set to a 1, a Modem Status Interrupt (IIR0-IIR3 = 0) is generated.

Bit 7	Data Carrier Detect (DCD) This bit indicates the logic state of the DCH# (RLSD#) output.
Bit 6	Ring Indicator (RI) This bit indicates the logic state of the RI# output.
Bit 5	Data Set Ready (DSR) This bit indicates the logic state of the DSR# output.
Bit 4	Clear to Send (CTS) This bit indicates the logic state of the CTS# output.
Bit 3	Delta Data Carrier Detect (DDCD) This bit is set to a 1 when the DCD bit changes state since the host last read the MSR.
Bit 2	Trailing Edge of Ring Indicator (TERI) This bit is set to a 1 when the RI bit changes from a 1 to a 0 state since the host last read the MSR.
Bit 1	Delta Data Set Ready (DDSR) This bit is set to a 1 when the DSR bit has changed since the host last read the MSR.
Bit 0	Delta Clear to Send (DCTS) This bit is set to a 1 when the CTS bit has changed since the MSR the host last read the MSR.

RBX – RX Buffer (Receiver Buffer Register)**(Addr = 0, DLAB = 0)**

The RX Buffer (RBR) is a read-only register at location 0 (with DLAB = 0). Bit 0 is the least significant bit of the data and is the first bit received.

THR – TX Buffer (Transmitter Holding Register)**(Addr = 0, DLAB = 0)**

The TX Buffer (THR) is a write-only register at address 0 when DLAB = 0. Bit 0 is the least significant bit and the first bit sent.

SCR – Scratch Register

(Addr = 7)

The Scratchpad Register is a read-write register at location 7. This register is not used by the modem and can be used by the host for temporary storage.

Divisor Registers

(Addr = 0 and 1, DLAB = 1)

The Divisor Latch LS (least significant byte) and Divisor Latch MS (most significant byte) are two read-write registers at locations 0 and 1 when DLAB = 1, respectively.

The baud rate is selected by loading each divisor latch with the appropriate hex value.

Programmable values corresponding to the desired baud rate are listed in Table on following page.

Programmable Baud Rates

Divisor Latch (Hex)		Divisor (Decimal)	Baud Rate
MS	LS		
06	00	1536	75
04	17	1047	110
03	00	768	150
01	80	384	300
00	C0	192	600
00	60	96	1200
00	30	48	2400
00	18	24	4800
00	0C	12	9600
00	06	6	19200
00	04	4	28800
00	03	3	38400
00	02	2	57600
00	01	1	115600
00	00	NA	230400

Application Notes

Tip and Ring Interface

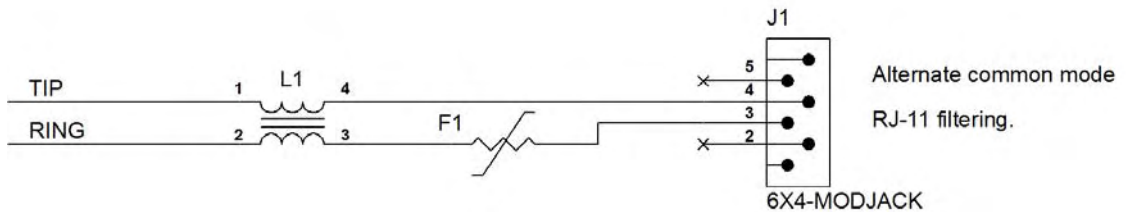
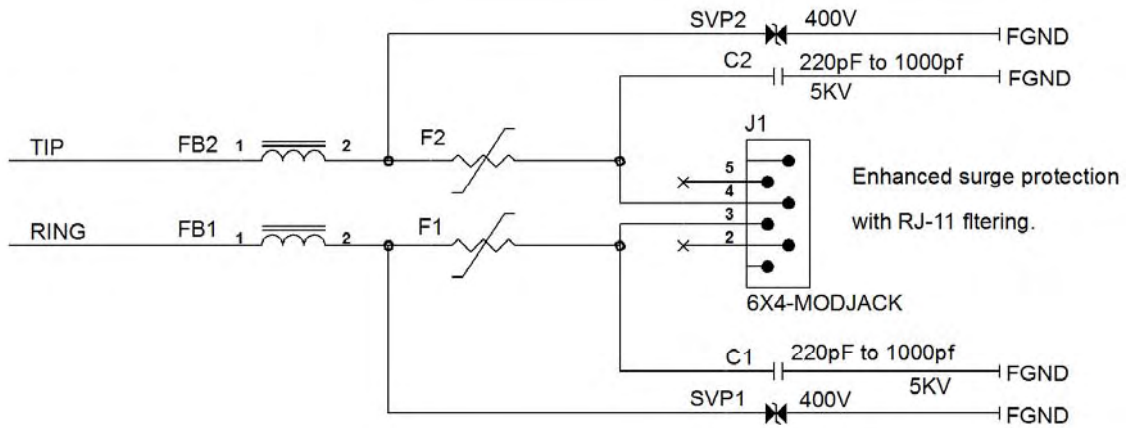
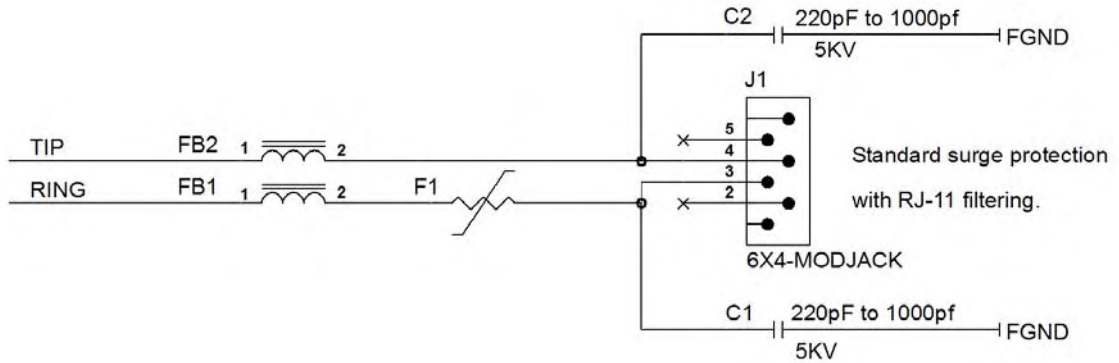

OEM Motherboard

Filtering and Surge Protection Options

See *Design Considerations* and *Recommended Parts* in Chapter 1.

Recommended Uses for Filtering Options

- Enhanced Surge Protection with RJ-11 Filtering**
 Use this option when additional lightning protection may be needed.
- Alternate Common Mode with RJ-11 Filtering**
 Use this option when your design has common mode emission issues.

Microphone and Speaker

Note: Applies to the MT5692SMI Voice only.

Microphone Input Option

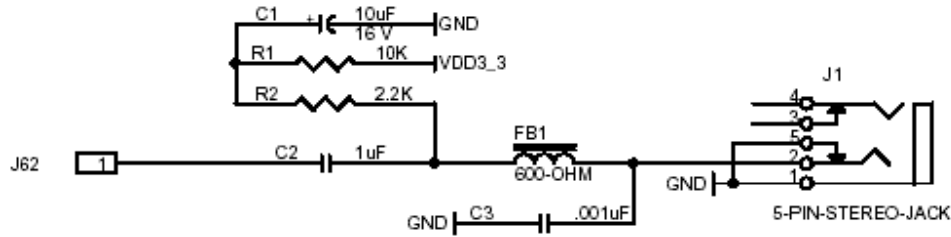

Speaker Output Option 1

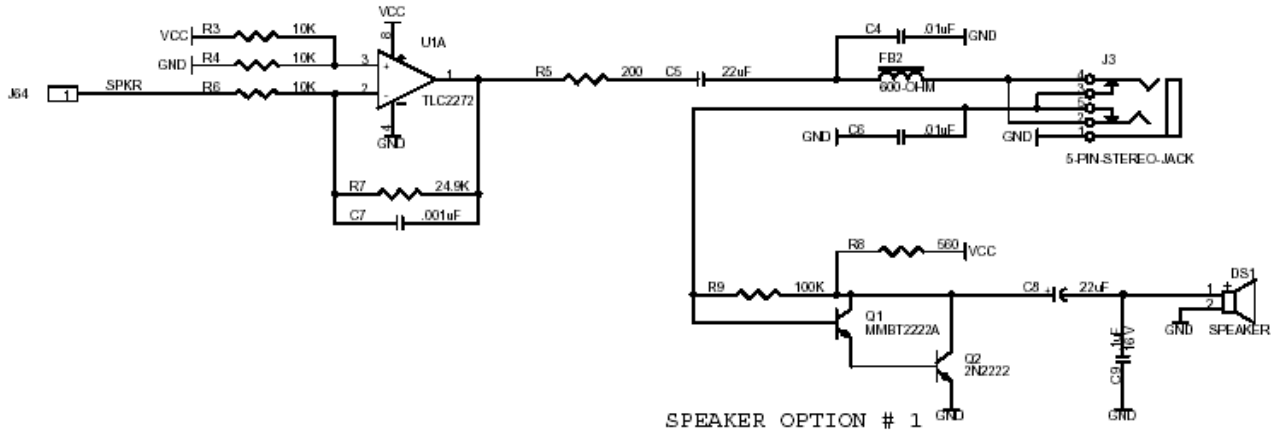

Speaker Output Option 2

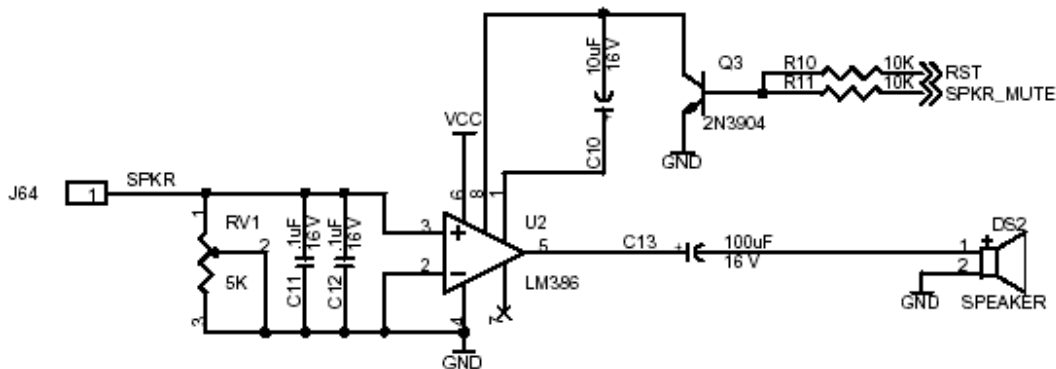
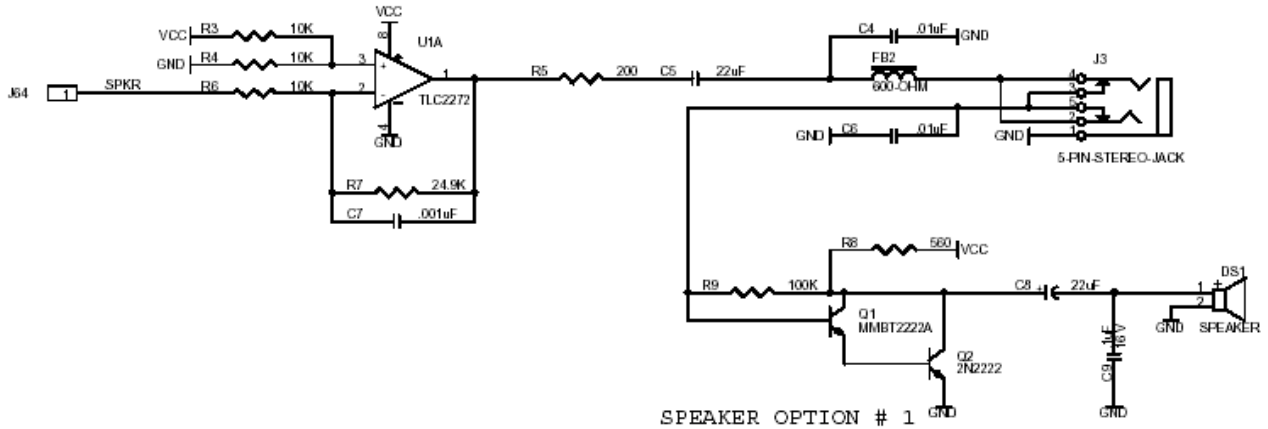

Differences between Speaker 1 Example and Speaker 2 Example

Speaker 1 does not have an amplifier while Speaker 2 does.

Specifications for the Microphone Input

Impedance	>70K ohms
AC Input Voltage Range	1.1V P-P
Reference Voltage	1.35V

Specifications for the Speaker Output from the Codec

Minimum Load	300 Ω
Maximum Capacitive Load	0.01 μ F
Output Impedance	10 Ω
AC Output Voltage Range	1.4V P-P
Reference voltage	+1.35 VDC
DC Offset Voltage	\pm 20 mV

Speaker Output

The speaker output from the codec is coupled to the speaker pin (64) through a 1 μ F cap and a 33 ohm resistor. The speaker pin is shared with the call progress monitor which is a digital I/O pin on the DSP that is coupled to the speaker pin through a 1 μ F and 3.9K.

Chapter 9 – SocketModem® (MT2492SMI)

Introduction

The Multi-Tech SocketModem MT2492SMI-xx utilizes the LSI CVxx Controller Based Modem Devices and the LSI CSP104 Silicon Direct Access Arrangement (DAA) to form a 2-chip complete embedded modem. This solution includes a DSP data pump, modem controller, on-chip RAM and ROM, codec, DAA, analog output, and 24.576 MHz clock input.

The modem accepts standard modem AT commands and provides connect rates up to 56 Kbps full-duplex over the Public Switched Telephone Network (PSTN) and features a complete set of modem protocols including all ITU-T standard formats up to V.92.

To provide the most flexibility, the CVxx modem system-side device provides numerous additional features for embedded modem applications. It includes call progress monitoring through standard result codes, error correction, data compression, autobaud, and fast connect modes. In addition, because the CVxx modem integrates the DAA, analog features (such as line-in use and over current detection) are included.

This device is ideal for embedded modem applications due to its simple host interface, small board space, and low power consumption.

Product Build Options and Ordering Information

Product	Description	Region	Order this Product ✓
MT2492SMI-92	V.92 Serial Data 5V	Regional	
MT2492SMI-34	V.34 Serial Data 5V	Regional	
MT2492SMI-22	V.22bis Serial Data 5V	Regional	
MT2492SMI-L-92	V.92 Serial Data 3.3V	Regional	
MT2492SMI-L-34	V.34 Serial Data 3.3V	Regional	
MT2492SMI-L-22	V.22bis Serial Data 3.3V	Regional	
Telecom Label			
MT2492SMI-LS	MT2492SMI-Regulatory Label	Regional	
Developer Kit			
MTSMI-UDK	Universal Developer Kit	Regional	

How to Read the Product Codes in the Table Above:

92	V.92/56K data rate
34	V.34/33.6K data rate
22	V.22bis data rate
L	3.3 Volt Build
LS	Telecom Label
UDK	Universal Developer Kit

Other Product Codes:

The complete product code may end in **.Rx**. For example, MT2492SMI-92.Rx. "R" indicates product revision. "x" is the revision number.

AT Commands Reference Guide

Product	Reference Guides Title and Document Product Number	Fax Commands	Voice Commands
SocketModem (MT2492SMI)	SocketModem MT2492SMI AT Commands Reference Guide (S000435x)	NA	NA

Technical Specifications

The SocketModem (MT2492SMI) meets the following specifications:

Category	Description
Data Standards	V.92, V.90, V.34, V.29, V.22bis, V.22, V.23, V.21; Bell 212A & Bell 103
Data Format	Serial, asynchronous
Character Format	10 bit
Serial/Data Speeds	Serial port data rates adjustable to 300, 1200, 2400, 4800, 9600, 19,200, 38,400, 57,600, and 115,200
Client-to-Client Data Rates	33,600, 31,200, 28,800, 26,400, 24,000, 21,600, 19,200, 16,800 bps 14,400, 12,000, 9600, 7200, 4800 bps 2400, 1200, 0-300 bps
Data Error Correction	V.42 (LAP-M or MNP 2–4)
Data Compression	V.42bis, MNP 5
Modes of Operation	Full duplex over dial-up lines; data mode, command mode, and online command mode
Weight	0.6 oz. (0.017 kg.)
Operating Temperature	0 to +70° C
Storage Temperature	-10° to +85° C
Humidity	20% to 90% (non-condensing)
Operating Voltage	Typical: 3.3VDC ± 5%; Absolute Maximum Supply Voltage: 3.6VDC Typical: 5VDC ± 5%; Absolute Maximum Supply Voltage: 5.25VDC
Power Measurements	See Power Measurements table in this chapter.
Transmit Sensitivity	-12 dBm (varies by country)
Receiver Sensitivity	-40 dBm (-43 dBm under worst case conditions)
DAA Isolation	1.5Kv r.m.s. or 2121 VDC at working voltage of 250VAC
Flow Control	XON/XOFF (software), RTS/CTS (hardware)
Command Buffer	50 characters
Compliance	<p>EMC Compliance</p> <ul style="list-style-type: none"> FCC Part 15 (Class B) Canadian EMC (Class B) EN 55022 (Class B) EN 55024 <p>Safety Compliance</p> <ul style="list-style-type: none"> UL/cUL 60950-1 EN 60950-1
Warranty	2 years

Mechanical Drawings – All Builds

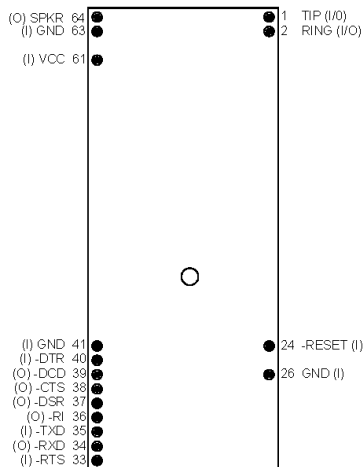
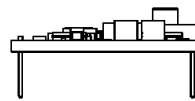
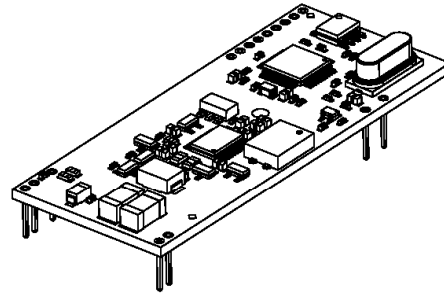

MT2492SMI-34
MT2492SMI-L-34
MT2492SMI-92
MT2492SMI-L-92

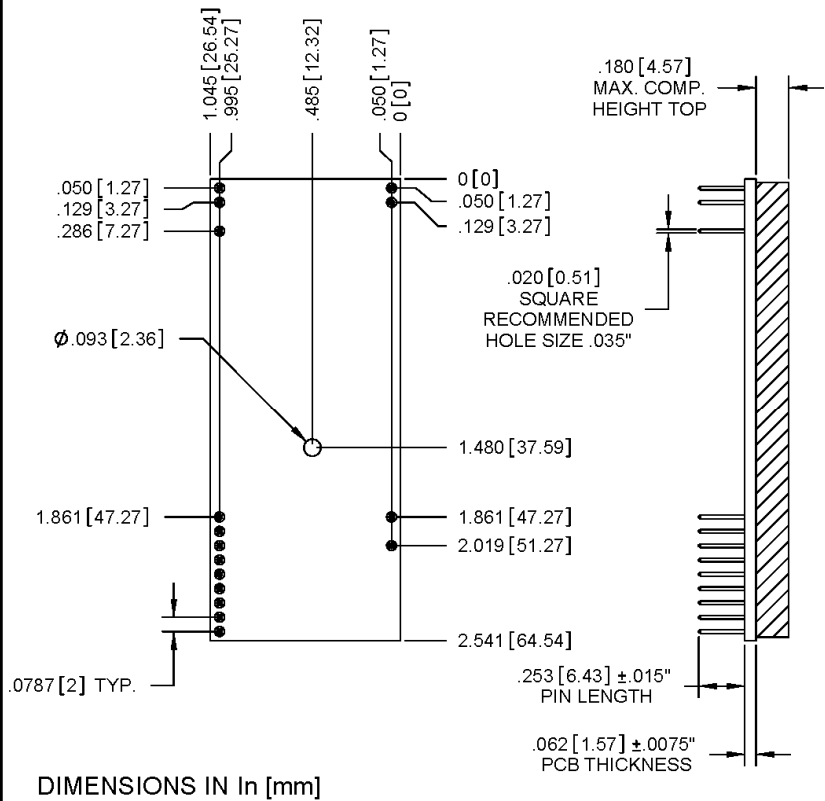

DC Electrical Characteristics

3.3V Serial SocketModem

3.3VDC Characteristics (VDD = 3.3V ± 0.3V) VDDMAX = 3.6V

Inputs	Input High	Input Low	
-DTR (40), -TXD (35), -RTS (33), -RESET (24)	Min 2.0V	Max 0.8V	
Outputs	Output High	Output Low	
-DCD (39), -CTS (38), -DSR (37), -RI (36), -RXD (34) 2mA, Z _{INT} = 120 Ω	Min 2.4V	Max 0.4V	
Digital Input Capacitance			50pF

5V Serial SocketModem

5VDC Characteristics (VDD = 5V ± 0.25V) VDDMAX = 5.25V

Inputs	Input High	Input Low	
-DTR (40), -TXD (35), -RTS (33), -RESET (24)	Min 2.0V	Max 0.8V	
Outputs	Output High	Output Low	
-DCD (39), -CTS (38), -DSR (37), -RI (36), -RXD (34) 2mA, Z _{INT} = 120 Ω	Min 2.4V	Max 0.4V	
Digital Input Capacitance			50pF

Power Measurements

MT2492SMI Measured Power* at Input Voltage 3.3

	Typical	Maximum
Current (AMPS)	86mA	96mA
Watts	283mW at 3.3VDC	345mW at 3.6VDC

MT2492SMI Measured Power* at Input Voltage 5.00

	Typical	Maximum
Current (AMPS)	88.5mA	94.8mA
Watts	442mW at 5.0VDC	498mW at 5.25VDC

* Multi-Tech Systems, Inc. recommends that the customer incorporate a 10% buffer into their power source when determining product load.

Application Notes

Tip and Ring Interface

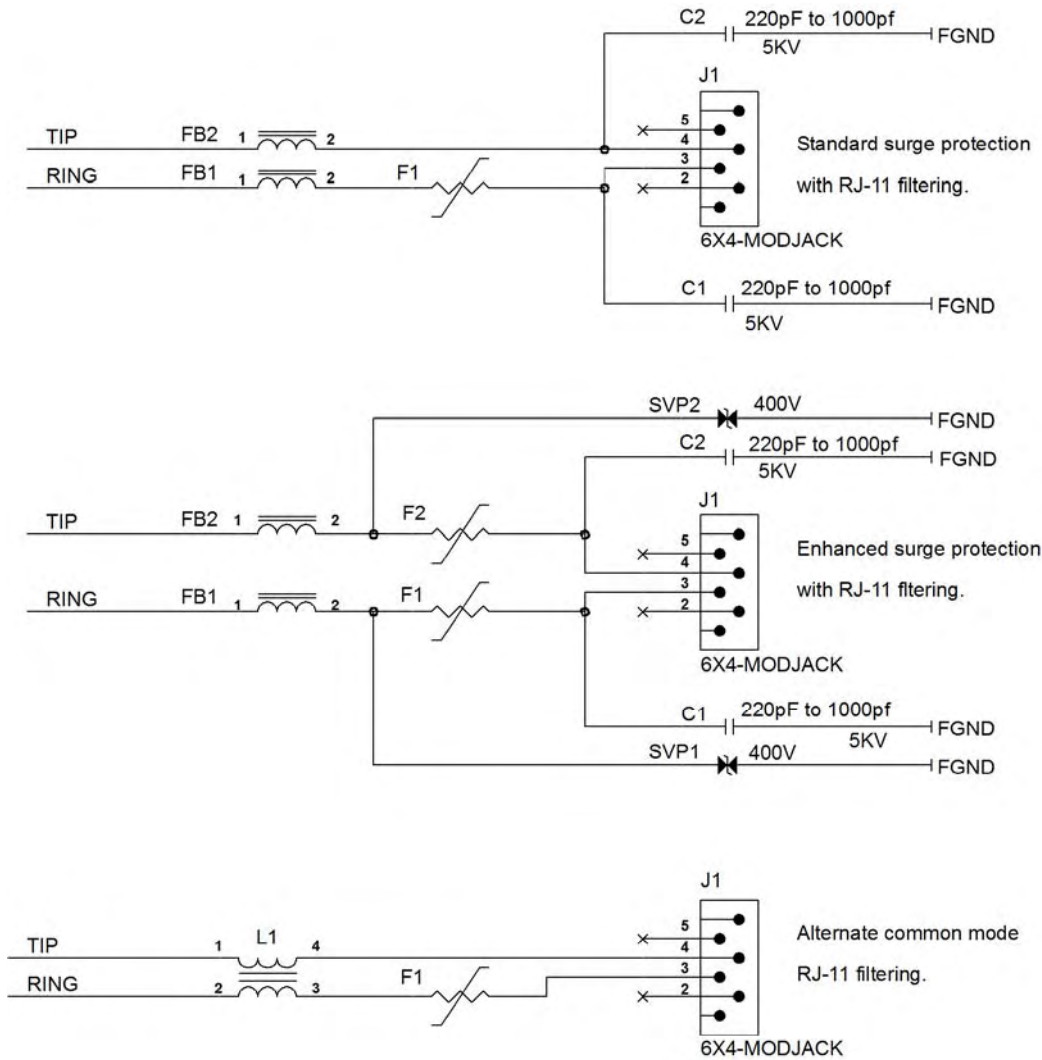

OEM Motherboard Filtering and Surge Protection Options

See *Design Considerations and Recommended Parts* in Chapter 1.

Recommended Uses for Filtering Options

- Enhanced Surge Protection with RJ-11 Filtering**
 Use this option when additional lightning protection may be needed.
- Alternate Common Mode with RJ-11 Filtering**
 Use this option when your design has common mode emission issues.

Part 4

Embedded Device Servers

- Chapter 10 – SocketEthernet IP (MT100SEM-IP)**
- Chapter 11 – SocketWireless Wi-Fi (MT810SWM-IP)**
- Chapter 12 – SocketWireless Bluetooth (MTS2BTSMI)**

Chapter 10 – SocketEthernet IP® (MT100SEM-IP)

Introduction

The **SocketEthernet IP®** (MT100SEM-IP) device server connects serial devices to an IP network for remote monitoring, control and configuration. The space efficient communications device (1" x 2.5") integrates Multi-Tech's Universal IP™ protocol stack and a serial-to-Ethernet interface into a single, universal socket design. The SocketEthernet IP can make your existing and next generation device, machine or system, IP-ready while you focus on developing its core features.

Product Build Options and Ordering Information

Product	Description	Region	Order this Product ✓
MT100SEM-IP			
MT100SEM-IP	Embedded Serial-to-Ethernet Device Server with Universal IP™ – 5V	Global	
MT100SEM-L-IP	Embedded Serial-to-Ethernet Device Server with Universal IP™ – 3.3V	Global	
MT100SEM-L-HV-IP	Embedded Serial-to-Ethernet Device Server with High Voltage Dielectric Isolation (EN60601) and Universal IP™ – 3.3V	Global	
Developer Kit			
MTSMI-UDK	Universal Developer Kit	Global	

How to Read the Product Codes in the Table Above:

IP	Universal IP™ Stack
L	3.3 Volt
HV	High Voltage Dielectric Isolation (EN60601)
UDK	Universal Developer Kit

Other Product Codes:

The complete product code may end in **.Rx**. For example, MT100SEM-L-IP.Rx
“R” indicates product revision. “x” is the revision number.

AT Commands Reference Guide

Product	Reference Guides Title and Document Product Number	Fax Commands	Voice Commands
Serial-to-Serial Device Server (MT100SEM-IP)	Multi-Tech Universal IP AT Commands (S000457x)	NA	NA

Technical Specifications

The SocketEthernet IP (MT100SEM-IP) meets the following specifications:

Category	Description
Interfaces	10/100BaseT Ethernet, Asynchronous Serial
Serial Character Format	8N1 (Data, Parity, and Stop bits are configurable)
Serial/Data Speeds	300 to 921600 bps
Ethernet Data Speeds	10MB or 100MB
Physical Description	2.541" L × 1.045" W × 0.680" H; 0.6 oz. (6.45 cm × 2.65 cm × 1.7 cm; 0.017 kg.)
Operating Temperature	-40° C to +85° C
Storage Temperature	-40° C to +85° C
Humidity	20% to 90% (non-condensing)
Operating Voltage	5VDC or 3.3VDC
Power Measurements	See the Power Measurements table.
Flow Control	RTS/CTS (hardware)
Network Protocols Supported	ARP, DHCP client, DNS client, FTP, ICMP (ping), IP, POP3, SMTP, TCP, Telnet server, UDP
Management	Serial Telnet Web-based configuration
Compliance	<p>EMC Compliance FCC Part 15 Class B Canada Class B EN 55022 Class B EN 55024</p> <p>Safety Compliance UL 60950 cUL 60950 EN 60950 AS/NZS 60950:2000</p> <p>Safety Compliance for High Voltage Build UL 60601-1 EN 60601-1</p>
Warranty	2 years

Mechanical Drawings - All Builds

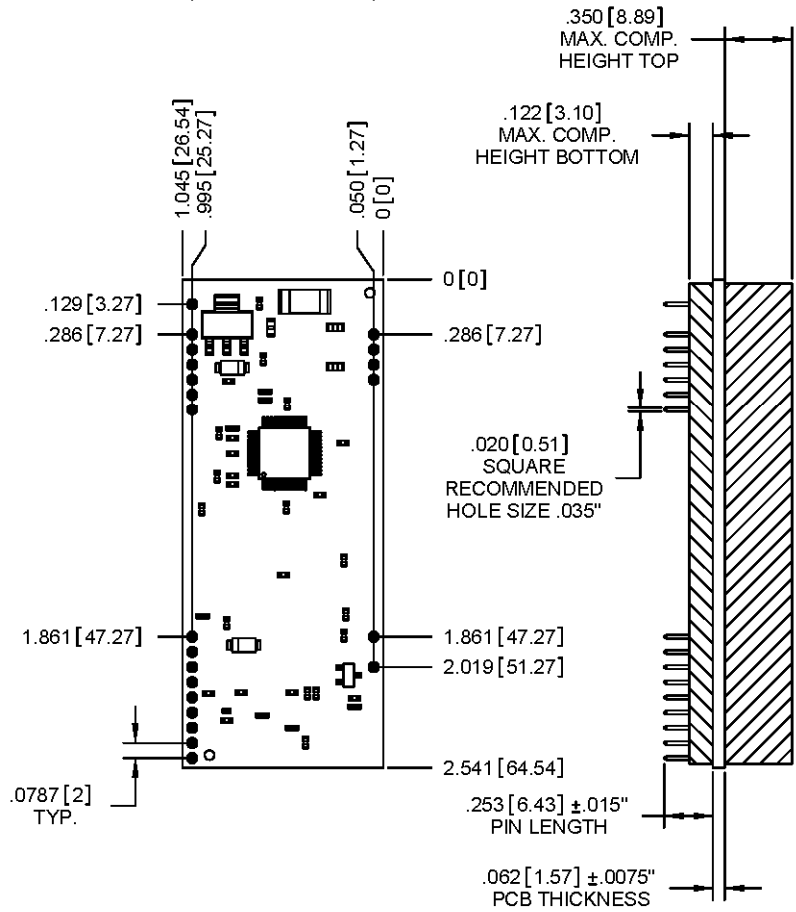
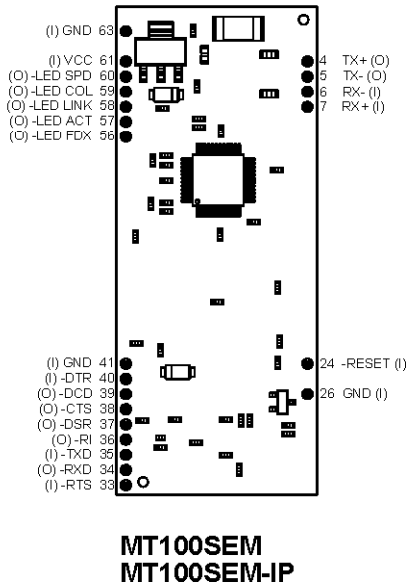
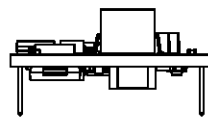
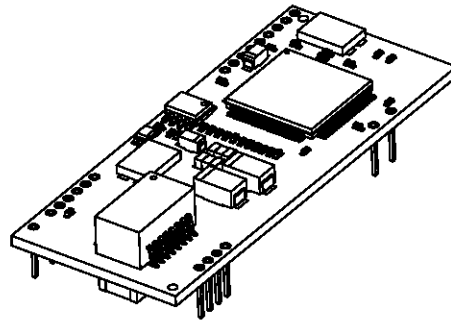

DIMENSIONS IN In [mm]

DC Electrical Characteristics

3.3V Serial

3.3VDC Characteristics (VDD = 3.3V ± 0.3V) VDDMAX = 3.6V

Parameter	Minimum	Maximum	
Input Low Level –DTR (40), –TXD (35), –RTS (33), –RESET (24) Note: These inputs are 5 volt tolerant	-0.3V	0.8V	
Input High Level –DTR (40), –TXD (35), –RTS (33), –RESET (24) Note: These inputs are 5 volt tolerant	Min 2.52V	VDD	
Output Low Level –DCD (39), –CTS (38), –DSR (37), –RI (36), –RXD (34)	NA	0.4V	Current Drive 2mA
Output High Level –DCD (39), –CTS (38), –DSR (37), –RI (36), –RXD (34)	Min. 2.3V	NA	Current Drive 2mA
Digital Input Capacitance – 5 pF			

5V Serial

5VDC Characteristics (VDD = 5V ± 0.25V) VDDMAX = 5.25V

Parameter	Minimum	Maximum	
Input Low Level –DTR (40), –TXD (35), –RTS (33), –RESET (24)	-0.3V	0.8V	
Input High Level –DTR (40), –TXD (35), –RTS (33), –RESET (24)	2.52V	VDD	
Output Low Level –DCD (39), –CTS (38), –DSR (37), –RI (36), –RXD (34)	NA	0.4V	Current Drive 2mA
Output High Level –DCD (39), –CTS (38), –DSR (37), –RI (36), –RXD (34)	2.3V	NA	Current Drive 2mA
Digital Input Capacitance – 5 pF			

Power Measurements

MT100SEM-IP Measured Power* at Input Voltage 5.00

	Sleep Mode	Typical	Maximum
Current (AMPS)	0.187	0.187	0.194
Watts	0.935	0.935	.97

MT100SEM-IP Measured Power* at Input Voltage 3.3

	Sleep Mode	Typical	Maximum
Current (AMPS)	NA	0.137	0.168
Watts	NA	0.411	0.504

* Multi-Tech Systems, Inc. recommends that the customer incorporate a 10% buffer into their power source when determining product load.

Application Notes

LED Interface

The LED signal is used to indicate the working status of the SocketModem.

LED 1 – Heartbeat LED

LED 1 Signal	Heartbeat LED
Blinking	The unit is functioning normally
Off	No power to the unit

Ethernet Interface - Non-Isolated Design

Note: VREF stands for Power in this drawing.

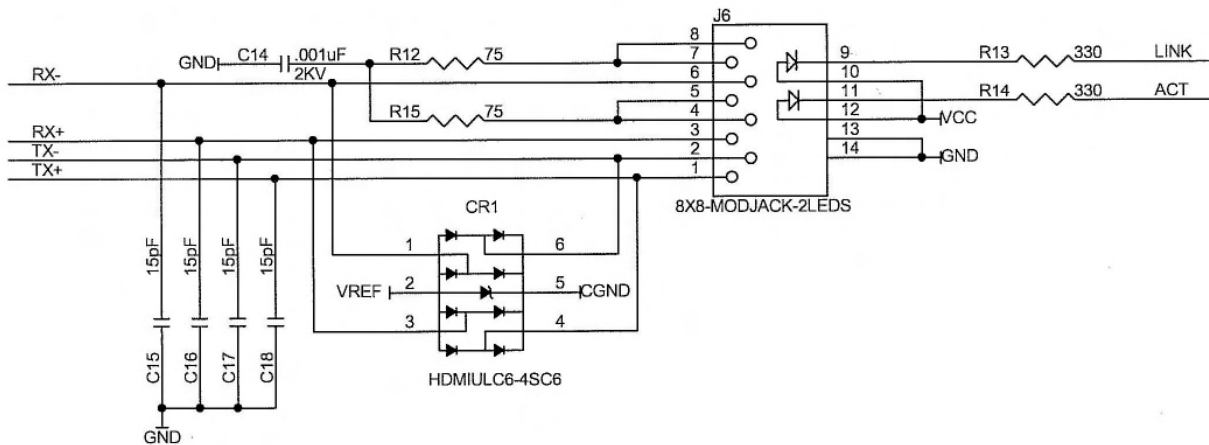

Ethernet Interface - Isolated Design

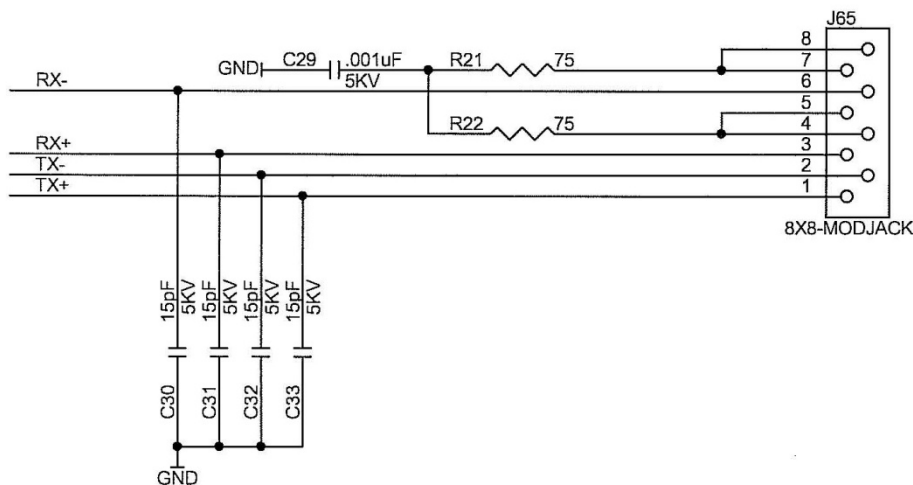

Isolated Design Application Note

The MT100SEM-L-HV-IP was designed to meet Basic Isolation at 240Vac according to the international medical directive for safety (EN60601-1). The recommended components for an isolated design comply with the same standard.

Recommended Parts

Recommended Capacitors for a Non-Isolated Design:

Manufacturer – NIC Components Corp.

Part Number – NMC0603NPO150J50TRPF

Recommended Safety Rated Capacitors for an Isolated Design: The recommended capacitors are Y2 rated and meet supplementary isolation at 240Vac along with the required creepages and clearances.

Manufacture – NOVACAP

Part Number – ES2211N(value)K502NXT

Recommended Resistor: The resistors are 75 ohms 1/8 watt.

Recommended Ethernet Modular Jack: The recommended jack is an eight contact, eight position, unshielded and ungrounded connector that will maintain the need isolation and spacing requirements. A shielded and grounded connector may be used, but special consideration must be made for the isolation and spacing requirements.

Manufacture – Stewart Connector Systems

Part Number – SS-6488-NF-K1

Note: These SocketEthernet parts are RoHS compliant.

The Windows-Based Auto-Discovery Manager

The Auto-Discovery Manager is a mechanism for remotely monitoring the Universal IP functioning. It also provides support for configuring several key parameters, such as DHCP Status (enable/disable), IP Address, and the Host Name of an MT100SEM-IP.

The Auto-Discovery mechanism is utilized by running a Windows-based Server Application that can monitor/configure the MT100SEM-IP. Communication between the MT100SEM-IP and the Windows-based Server is through MAC level broadcasts on a configured UDP port.

Two Ways to Use Auto Discovery: Auto-Discovery can be performed by using AT Commands (see the Universal IP AT Commands Reference Guide – included on the Universal Kit CD) or by using the Auto-Discover Manager Software (also included on the Universal Kit CD).

Auto-Discovery Manager Software

The Auto-Discovery Manager is composed of two components:

- **The Client Component** – The Client component periodically broadcasts its current configuration over the network.
- **The Server Component** – The Server component receives the broadcasts from the client.

Client Component

The Auto-Discovery Client component is integrated with MT100SEM-IP. It broadcasts its current configuration over the network on a specific UDP SERVER-PORT. By default the SERVER-PORT is set to 1020. The configuration parameters broadcast are

- Version details
- MAC Address
- Static IP Address
- DHCP Status
- DHCP Assigned IP Address
- Host Name
- Broadcast interval
- Port number on which the client listens

Auto-Discovery Manager Software – Server Component

The server component provides server side support software for the remote user. It listens on the SERVER-PORT and receives the broadcasts from the client and updates the list of configuration parameters. This list can be viewed through the User Interface:

The List of Entries →

S.No	MAC ADDRESS	IP ADDRESS	HOST NAME	DHCP STATUS	DHCP IP ADDRESS	CLIENT STATUS	F/W VERSII
1	00.CO.AD:34:56:CA...	192.168.2.1	SocketEthernetIP	Enabled	192.168.7.5	Active	VER - 1.01
2	00.CO.7A:8B:4C:...	192.168.2.121	IPModule	Disabled	255.255.255.255	InActive	VER - 1.00

Detailed Information about a Selected Entry →

MAC ADDRESS: 00.CO.AD:34:56:CA HOSTNAME: SocketEthernetIP
 IP ADDRESS: 192.168.2.1 CLIENT PORT NUMBER: 1020
 SUBNET MASK: 255.255.255.0
 DHCP IP ADDRESS: 192.168.7.5 BROADCAST TIMER: 30
 DHCP SUBNET MASK: 255.255.255.0 F/W VERSION: VER - 1.01
 DHCP STATUS: CLIENT ACTIVITY STATUS:

Log Files will display here →

How to View the Detailed Information

New entries are appended to the list shown on the screen above. Only the first ten entries are displayed on the screen. However the administrator can scroll down to view more entries. Clicking on an entry displays the detailed information about that entry.

How to Edit the List and Make the Changes Permanent

1. Double-click on the entry you wish to edit.
2. After clicking the desired entry, a new dialog box displays showing the current configuration.

The screenshot shows a dialog box titled "Auto Discovery Manager - Edit Attributes". Inside the dialog, there is a section labeled "Edit" containing the following fields and controls:

- MAC ADDRESS: 00:08:00:D2:02:3F
- IP ADDRESS: 192 . 168 . 2 . 1
- SUBNET MASK: 255 . 255 . 255 . 0
- DHCP STATUS:
- DHCP IP ADDRESS: 000.000.000.000
- DHCP SUBNET: 000.000.000.000
- HOSTNAME: SocketEthernetIP
- CLIENT PORT: 9999
- CLIENT ACTIVITY STATUS:
- BROADCAST TIMER: 10
- VERSION: 1.99

At the bottom of the dialog, there are four buttons: SET, RESET, RESTORE DEFAULTS, and CANCEL.

3. Enter the new parameters and click the **SET** button. The server sends the modified parameters to the client.

Upon receiving the broadcast from the Server, the Client validates the packet. The Client determines whether the packet is destined for its own MAC Address. If so, it sets the modified parameters that are different from its current configuration, and then it broadcasts the newly configured parameters.

The Client Status is set to **Active** upon the receipt of a broadcast packet.

The Client Status is made **Inactive** if there is no request from the client for a stipulated period. (3 * periodic timer value).

How to Set the Parameters to the Previous Configuration

When the **RESET** button is clicked, the parameters are set to the defaults received. In other words, **RESET** is similar to **UNDO** (it sets the modifications to the previous ones).

Saving the Log

The logs can be saved to a file. They are spooled into the third part of the window in the main dialog box. To save the log: Select **File > Save Log As**.

Chapter 11 – SocketWireless® Wi-Fi® (MT810SWM-IP)

Introduction

The SocketWireless® Wi-Fi® device server connects serial devices to an IP network via 802.11b/g cellular networking. It enables you to build cellular networking into virtually any device allowing for remote monitoring, control and configuration. The space efficient communications device (1" x 2.5") integrates a complete TCP/IP protocol stack. It can make your existing and next generation device, machine or system, IP-ready while you focus on developing its core features.

Product Build Options and Ordering Information

Product	Description	Region	Order this Product ✓
MT810SWM-IP	802.11b/g Wi-Fi Device Server with IP, 5V	Regional	
MT810SWM-L-IP	802.11b/g Wi-Fi Device Server with IP, 3.3V	Regional	
Developer Kit			
MTSMI-UDK	Universal Developer Kit	Regional	

How to Read the Product Codes in the Table Above:

IP	Universal IP™ Stack
L	3.3V
UDK	Universal Developer Kit

Other Product Codes:

The complete product code may end in **.Rx**. For example, MT810SWM-IP.Rx
“R” indicates product revision. “x” is the revision number.

AT Commands Reference Guide

Multi-Tech Systems, Inc. provides documentation of AT Commands for each embedded module. These AT Command Reference Guides are available on the CD included in the Developer Kit and are also available by request. Send an email to oemsales@multitech.com to request the copy you desire.

Product	Reference Guides Title and Document Product Number	Fax Commands	Voice Commands
SocketWireless Wi-Fi Device Server (MT810SWM-IP)	Multi-Tech's Universal IP AT Command Reference Guide (S000457x)	NA	NA

Technical Specifications

The SocketWireless Wi-Fi meets the following specifications:

Category	Description
Cellular Specifications	
WLAN Standard	IEEE 802.11b/g Wi-Fi
Frequency Range	2.400 to 2.484 GHz
Data Rate	1, 2, 5.5, 6, 9, 11, 12, 18, 24, 36, 48 & 54Mbps
Maximum Transmit Power	15 dBm
Receiver Sensitivity	-82 dBm (with PER < 8%)
Security	64/128 bit WEP, WPA-PSK, WPA2, WPA2-PSK
Mode	Ad Hoc, Infrastructure
Antenna Connector	UFL
Serial Interface	
Data Format	Serial, asynchronous
Data Rate	Software selectable: 1200 bps to 921.6K bps
Data Bits	7 or 8 data bits, 0 or 1 stop bits
Parity	Odd, even, none
Flow Control	RTS/CTS (Hardware), None
Network Protocol Support	
Protocols Supported	ARP, DHCP Client, DNS Client, FTP Client, ICMP (PING), IP, POP3 Client, SMTP Client, TCP Client & Server, UDP Client & Server
Power Requirements*	
Supply Voltage	3.3VDC or 5VDC
Power Usage	See <i>Power Measurements</i> section later in this chapter
Environmental	
Operating Temperature	-30° to +70° C
Storage Temperature	-40° to +85° C
Humidity	20% to 90% (non-condensing)
Physical Description	
Dimensions	2.541" L x 1.045" W x 0.680" H (6.45 cm x 2.65 cm x 1.7 cm)
Weight	0.6 oz. (0.017 kg.)
Certifications, Approvals, Warranty	
Compliance	<p>EMC Compliance</p> <ul style="list-style-type: none"> FCC Part 15 Subpart C Canada RSS-210 EN 300 328 EN 301 489-17 <p>Safety Compliance</p> <ul style="list-style-type: none"> UL 60950-1 cUL 60950-1 IEC 60950-1
Warranty	Two years

Mechanical Drawings – Basic Build

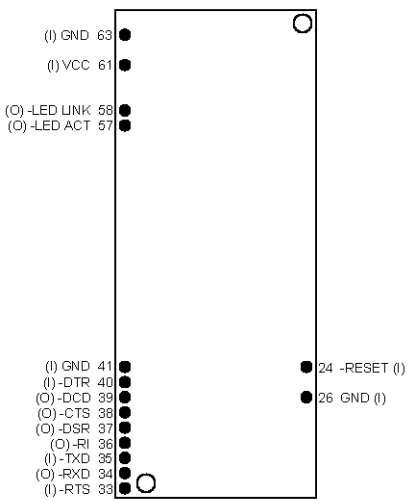
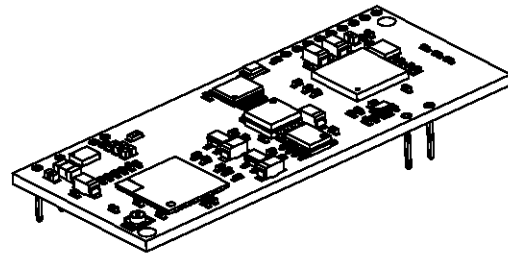

MT810SWM-IP

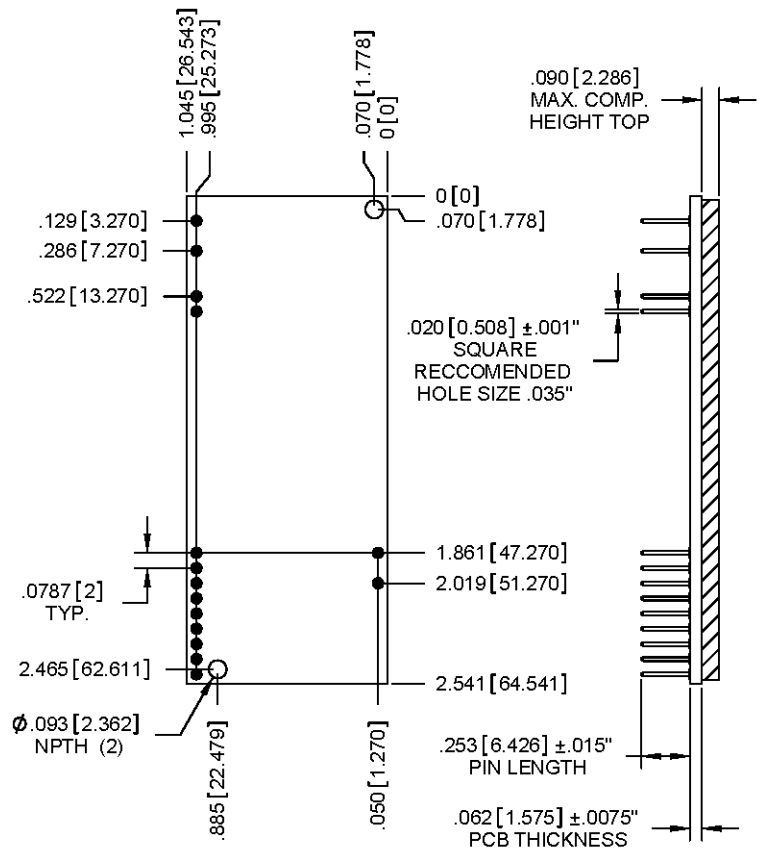

NOTES: DIMENSIONS IN In [mm]

Mechanical Drawings – 3.3V Build

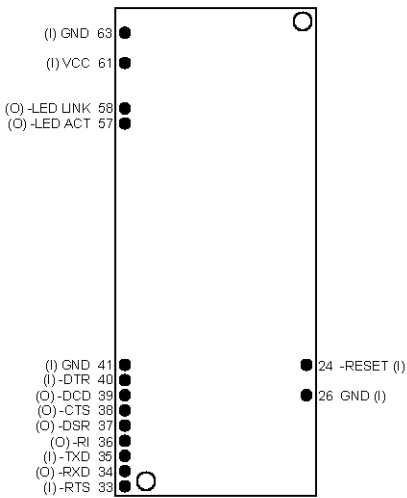
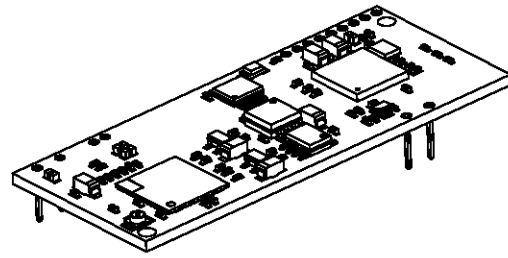

MT810SWM-L-IP

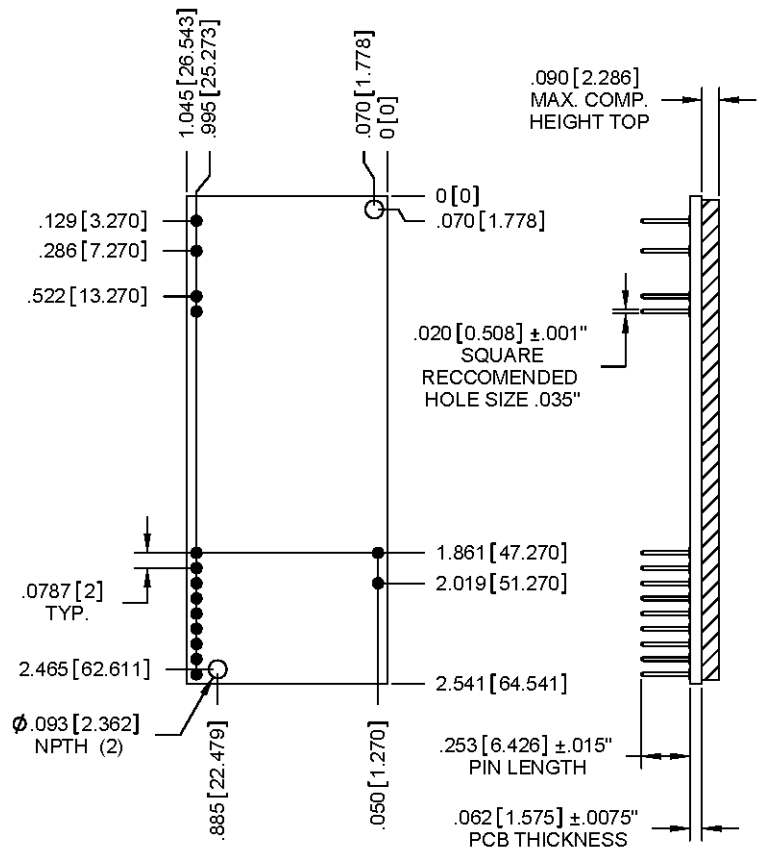

NOTES: DIMENSIONS IN In [mm]

Operating Conditions

In Volts

Parameter	Minimum	Maximum
Supply Range - Vcc	3.3V = 3.15	3.3V = 3.45
	5V = 4.75	5V = 5.25

Absolute Maximum Rating

Parameter	Minimum	Maximum
Voltage at any signal pin	GND - 0.3V	Vcc + 0.3V

DC Electrical Characteristics

For 5V and 3.3V

Parameter	Units (Volts)	
	Minimum	Maximum
Digital Signal Input Low Level	GND	0.8V
Digital Signal Input High Level	2.0V	Vcc
Digital Signal Output Low Level	NA	0.4V
Digital Signal Output High Level	2.4V	NA
Reset (Low Active) Input Low	GND	0.8V
Reset (Low Active) Input High	2.0V	Vcc
Digital Input Capacitance	5pf	

Power Measurements

MT810SWM-IP Measured Power* at Input Voltage: 3.3 Volts

	Idle	Typical	Maximum
Current (AMPS)	0.057	0.180	0.260
Watts	0.182	0.531	0.764

MT810SWM-IP Measured Power* at Input Voltage: 5.00 Volts

	Idle	Typical	Maximum
Current (AMPS)	0.056	0.193	0.260
Watts	0.274	0.897	1.196

* Multi-Tech Systems, Inc. recommends that the customer incorporate a 10% buffer into their power source when determining product load.

Application Notes

LED Interface

The LED signal is used to indicate the working status of the SocketModem.

LED 1 – Heartbeat LED

LED 1 Signal	Heartbeat LED
Blinking	The unit is functioning normally
Off	No power to the unit

Default Power Up Settings

Baud Rate = 115200 bps
Data Bits = 8 bits
Parity = None
Stop bits = 1 bit
Hardware Flow Control RTS/CTS = Disabled

Note:

See Chapter 1 for Antenna System details. Note that the cable for the Wi-Fi SocketModem has a reverse polarity SMA plug.

Regulatory Requirements for the Wi-Fi Antenna

This section covers how to use the modular transmitter in order to maintain the modular transmitter approval and RF exposure compliance.

Conditions to Satisfy Modular Transmitter Approval

This device is intended only for use by OEM integrators under the following 3 conditions:

1. The antenna must be installed such that 20 cm is maintained between the antenna and the end user for all installations.
2. The transmitter module may not be located with any other transmitter or antenna.
3. The communications device is approved using the FCC "unlicensed modular transmitter approval" method. Therefore, the communication device must only be used with the originally approved antennas.

As long as the 3 conditions above are met, further transmitter testing will not be required. However, the OEM integrator is still responsible for testing their end-product for any additional compliance requirements with this communication device installed (for example, digital device emissions, PC peripheral requirements, etc.)

IMPORTANT NOTE: In the event that any of these conditions CANNOT be met (for example certain laptop configurations, location with another transmitter, or use of a different type antenna), then the FCC authorization for the communications device is no longer considered valid and the FCC ID CANNOT be used on the final product. In these circumstances, the OEM integrator will be responsible for re-evaluating the end product (including the transmitter) and obtaining a separate FCC authorization.

RF Exposure Statements Developers Must Include in the User Manual for End Users

The user manual for consumers must include the following information in a prominent location:

IMPORTANT NOTE: To comply with FCC RF safety exposure limits, the antenna used for this transmitter must be installed to provide a separation distance of at least 20 cm from all persons and must not be located or operating in conjunction with any other antenna or transmitter.

Regulatory Requirements for End Product Labelling

Suggested End Product Labeling

This transmitter module is authorized only for use in devices where the antenna may be installed in such a way that 20 cm may be maintained between the antenna and the users (for example access points, routers, cellular ASDL modems, and similar equipment). The final end product must be labeled in a visible area on the exterior of the enclosure with the following or similar text: "Contains TX FCC ID: AU792U07B06821".

FCC & IC Information to Consumers

The user manual for the consumer must contain the statements required by the following FCC and IC regulations: 47 C.F.R. 15.19(a)(3), 15.21, 15.101 and RSS-Gen Issue 2 dated June 2007, Sections 7.1.4 and 7.1.5.

Additional Information That Must Be Provided to OEM Integrators

The end user should NOT be provided any instructions on how to remove or install the modular transmitter.

Chapter 12 – SocketWireless® Bluetooth® (MTS2BTSMI)

Introduction

The Multi-Tech Systems, Inc. SocketWireless® with Bluetooth®-enabled technology allows developers to establish cellular networks using a special set of AT commands. The SocketWireless with Bluetooth technology makes the cable-replacement transition to cellular networks seamless and easy.

This chapter explains how to establish Bluetooth communication between two serial devices for data applications in a point-to-point network. Bluetooth-enabled devices create communication-ready devices by integrating data functionality into a single, universal socket design. This complete, ready-to-integrate device dramatically reduces development time and costs for system designers.

Notes about Byte Gaps and Data Latency

Because of the way Bluetooth is designed and operates, random byte gaps of 5 ms to 20 ms are common. Packet size will vary from transmission to transmission.

Although the serial band frequency operates up to 920K bps, effective data throughput in fast streaming mode is approximately 200K bps. Effective data throughput in regular data mode is 60K bps. The reason for the slower speed in regular mode is due to the AT parser, which looks at each character for ASCII valid command scripts in the regular mode's data stream.

The SocketWireless RX has very limited buffering, so if you do not use hardware flow control and are transmitting further distances, you will quickly overflow the 50 byte buffer because of RF retransmissions, etc.

When a Bluetooth connection is made, the SocketWireless device goes into regular data mode per the power-up factory default settings. This enables the user to configure the SocketWireless settings remotely via a remote RF Bluetooth connection. Basically, you can setup the SocketWireless device so no commands are required to be sent from the embedded side of the device. This allows seamless interfacing with legacy systems without the need to modify the host device

Product Build Options and Ordering Information

Product	Description	Region	Order this Product ✓
MTS2BTSMI	Embedded Serial-to-Bluetooth, C1, 5V	Global	
MTS2BTSMI-L	Embedded Serial-to-Bluetooth, C1, 3.3V	Global	
Developer Kit			
MTSMI-UDK	Universal Developer Kit	Global	

How to Read the Product Codes in the Table Above:

C1 Class 1 Bluetooth
L 3.3V
UDK Universal Developer Kit

Other Product Codes:

The complete product code may end in .Rx. For example, MTS2BTSMI-L.R2.
"R" indicates product revision. "x" is the revision number.

AT Commands Reference Guide

Product	Reference Guides Title and Document Product Number	Fax Commands	Voice Commands
SocketWireless Bluetooth (MTS2BTSMI)	SocketWireless Bluetooth AT Commands Reference Guide (S000360x)	NA	NA

Technical Specifications

The SocketWireless Bluetooth (MTS2BTSMI) meets the following specifications:

Category	Description
Standard	Class 1 Bluetooth V2.0 compliant Note: For Bluetooth protocol V2.0, the circuit board I/O pin 7 now controls flow control. In V1.2, circuit board I/O pin 3 controlled flow control. V2.0 now supports multipoint connections.
Frequency Range	2402 to 2480 MHz (2.402 to 2.480 GHz)
Data Format	For Serial Interface - Asynchronous
Serial Speeds	Supports speeds from 1200 bps to 920K bps
Flow Control	Hardware
Output Level (Class 1)	20dBm maximum
Modes of Operation	Inquiry, Idle, Data, Fast Data, Park, Sniff, Command, Master, Slave
Device Profiles	Serial Port (SPP), Dial-up Network (DUN)
Buffer	Serial 50 bytes RF 50-byte RX buffer
Weight	0.6 oz. (0.017 kg.)
Power Measurements	See Power Measurements table later in this chapter.
Operating Temperature	-40° to +70° C
Storage Temperature	-40° to +85° C
Humidity	20% to 90% (non-condensing)
Operating Voltage	5VDC or 3.3VDC Minimum and Maximum Voltage: 3.3VDC \pm 0.1V & < 10mVp-p noise 5VDC \pm 0.1V & < 10mVp-p noise
Compliance	EMC Compliance FCC Part 15.247:2004 (subpart C) EN 301 489-1 V1.4.1 (2002-08) Safety Compliance UL 60950 cUL 60950 EN 60950 AS/NZS 60950:2000
Warranty	Two years

Mechanical Drawing – Basic Build and 3.3V Build

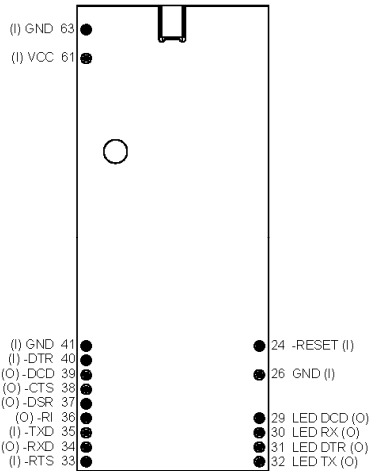
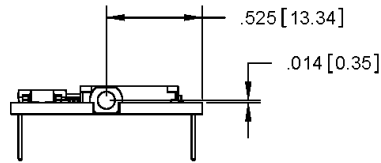
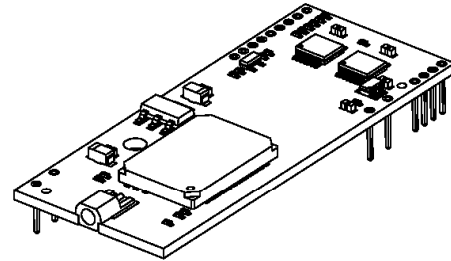

**MTS2BTSMI
MTS2BTSMI-L**

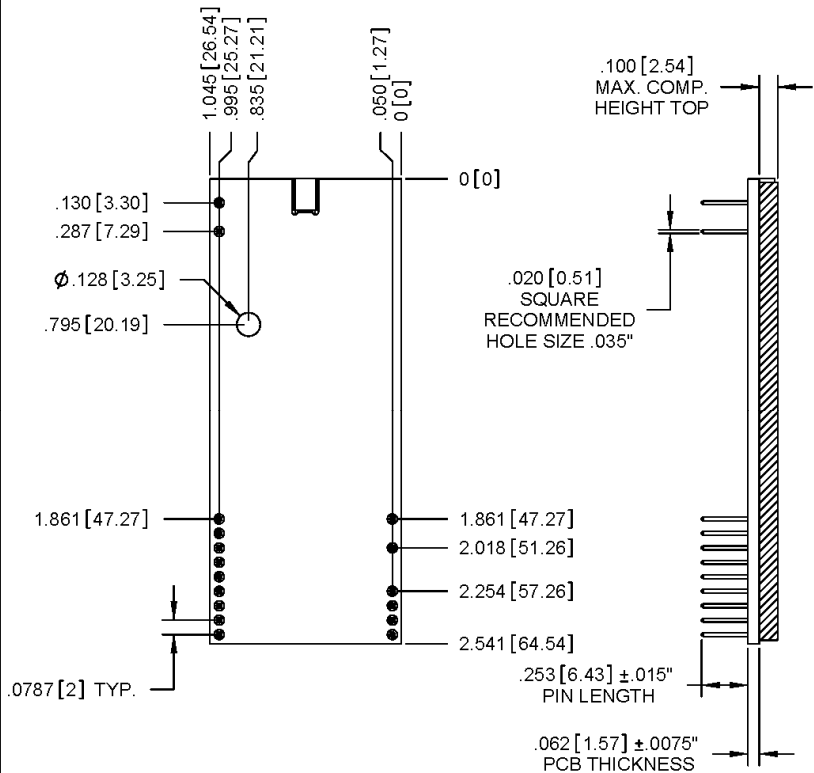

DIMENSIONS IN In [mm]

DC Electrical Characteristics

5V Serial SocketWireless

5VDC Characteristics (VDD = 5V ± 0.25V) VDDMAX = 5.25V

Inputs	Input High	Input Low	
-DTR (40), -TXD (35), -RTS (33)	Min 2.0V	Max 0.8V	
-RESET (24)	Min 2.0V	Max 0.8V	
Input Capacitance			15 pF
Outputs	Output High	Output Low	Current Drive
-DCD (39), -CTS (38), -RI (36), -RXD (34)	Min 4V / 2.4V	Max 0.5V / 0.5V (5V / 3.3V)	3.2mA, 7.0mA for TXD

3.3V Serial SocketWireless

3.3VDC Characteristics (VDD = 3.3V ± 0.3V) VDDMAX = 3.6V

Inputs	Input High	Input Low	
-DTR (40), -TXD (35), -RTS (33)	Min 2.0V	Max 0.8V	
-RESET (24)	Min 2.0V	Max 0.8V	
Input Capacitance			15 pF
Outputs	Output High	Output Low	Current Drive
-DCD (39), -CTS (38), -RI (36), -RXD (34)	Min 2.4V	Max 0.5V / 0.5V (5V / 3.3V)	3.2mA, 7.0mA for TXD

Power Measurements

Power* Measurement at 3.3 Voltage

	Idle	Master Unconnected	Master Connected	Fast Data	Master Inquiry (Maximum)	Deep Sleep Mode	Slave Unconnected	Slave Connected
Current (AMPS)	1.5mA	1.5mA	6mA	21mA	68mA	70µA	45mA	21mA

Power* Measurement at 5.00 Voltage

	Idle	Master Connected	Fast Data	Master Inquiry (Maximum)
Current (AMPS)	1.6mA	7mA	38mA	74mA

Note: These power measurements were taken with no LEDs connected.

Driving an LED through 330 ohm resistor to GND draws an additional 4mA on 5V for each LED.

* Multi-Tech Systems, Inc. recommends that the customer incorporate a 10% buffer into their power source when determining product load.

Application Notes

Antenna

See Chapter 1 for Antenna System details. Note that the cable for the Wi-Fi SocketModem has a reverse polarity SMA plug.

Default Power Up Settings

AT Command Response Form = Long Form
 Bluetooth Service Profile = Serial Port Profile {SPP}
 Device Role = Slave
 Baud Rate = 9600bps
 Data Bits = 8 bits
 Parity = None
 Stop bits = 1 bit
 Hardware Flow Control RTS/CTS = Enabled
 Power Mode = Never go into deep sleep mode
 Country Code = North America and Europe
 Name of Device (local name) = SocketWireless
 My Radio Status = 1,0 {slave, disconnected}
 Service Name = COM0
 Power up default ATSW24 settings = 0,0,0,0 {long response, no authentication, no auto SCO connect, no minor}
 Power up default ATSW25 settings = 0,1,0,0 {slave, data, allow data to pass, SPP}
 Major & Minor Class Of Device (COD) = 00000000 {undefined}
 Security PIN and Encryption Disabled
 Default PIN = "default" *caps sensitive so do not use any capital letters*

Important Security PIN Note:

Do not forget your PIN. Write it down. If you forget it, there is no way it can be retrieved from the device or the software. You will have to buy a new SocketWireless Bluetooth and start over.

Page Scan Interval = 0x400 {2560msec.}
 Page Scan Window = 0x200 {11msec.}
 Inquiry Scan Interval = 0x400 {2560msec.}
 Inquiry Scan Window = 0x200 {11msec.}
 Timeout Connection Parameters
 Inquiry = 60 seconds
 Slave Connect = 60 seconds
 Master Connect = 60 seconds
 ATDM idle mode = 60 seconds
 ATDM Master Mode = indefinitely (need to perform **ATUCL** to cancel last command)
 Timeout for loss of Bluetooth connection = 4 seconds

Example of a Master Discovery/Connection Sequence

From Power Up and No Connection

1. Verify local device is Master in Data Mode.
Sent: ATSi,7 <cr>
Reply: <cr_lf>1,1,0,0<cr_lf>
2. If not Master, set to Master and Data Mode.
Sent: ATSW25,1,1,0,0 <cr>
Reply: <cr_lf>OK<cr_lf>
3. Perform an Inquiry to obtain BT Address (unless it is already known).
Sent: ATUCL<cr> // Clears radio state and places in Idle Mode
Reply: <cr_lf>OK<cr_lf>
Sent: ATDI,1,00000000 {Class of Device}<cr> // Looks for only one Bluetooth device
Reply: <cr_lf>00A0961F2023,00000104,Socket Wireless<cr_lf>
<cr_lf>DONE<cr_lf>
4. Perform a Master Connect over SPP using the BT Address.
Sent: ATDM, 00A0961F2023,1101<cr> // SPP connection
Reply: <cr_lf>CONNECT,00A0961F008F <cr_lf> // Returns Slave BT address radios is in Data Mode
5. Place radio into Fast Data Mode.
Sent: ATMF<cr> // Places radio in Fast Data Mode
Reply: <cr_lf>OK<cr_lf>
6. Send Data.

Note: When sending commands from the Slave when the Slave connects in Fast Data Mode (ATSW25/or issuing ATMF). All valid AT commands are sent through the Slaves UART will be interpreted and responded by the Master radio as if it was the local Slave radio. Basically in this configuration from the Slave end you can obtain status and configure from the remote Master radio. This is a unique feature that may be useful in some applications but can confuse the user if you think you are talking to the local Slave UART.

To Get Out of Data Mode and Check Status:

1. Delay at least 50 milliseconds; this could be less or more.
2. Get into Command Mode.
Sent: +++<cr> // Default escape sequence of characters
Reply: <cr_lf>OK<cr_lf>
3. Check Status
Sent: AT<cr>
Reply: <cr_lf>OK<cr_lf>
4. Or send any AT Command example:
Sent: ATSi,0<cr>
Reply: <cr_lf>SocketWireless AT<cr_lf>

Example of a Slave Command Sequence

From Power Up:

1. Check and verify Communication to Slave.
Sent: AT<cr>
Reply: <cr_lf>OK<cr_lf>
2. Get information on Slave Bluetooth address.
Sent: ATSi,1<cr>
Reply: 12-digit address
<cr_lf>OK<cr_lf>
3. Set Slave to automatically connect in Fast Data Mode on Bluetooth connection.
Sent: ATSW25,0,0,0,0 <cr>
Reply: <cr_lf>OK<cr_lf>
4. Either cycle power or send ATURST.
Note: This command sequence assumes the radio is in factory default in which it automatically comes up and is connectable as a Slave from a Master request.

Disabling Flow Control Using AT Commands

Protocol Change:

For Bluetooth protocol V2.0, the circuit board I/O pin 7 now controls flow control.

<i>Previous Protocol V1.2</i>	<i>New Protocol V2.0</i>
ATSW22,3,x,x	ATSW22,7,x,x
ATSW23,3,x,x	ATSW23,7,x,x

Disabling Flow Control Using Protocol V.2.0

Using a terminal screen with flow control enabled, issue commands to turn off flow control.

```

Sent:  ATSW22,7,1,0 <cr>      // Set PIO7 as output and do not store in flash
Reply:  OK<cr_lf>
Sent:  ATSW23,7,1,0<cr>      // Set PIO7 output high and do not store in flash
Reply:  OK<cr_lf>

```

To store the setting in flash:

```

Sent:  ATSW22,7,1,1<cr>      // Set PIO7 as output and store in flash
Reply:  OK<cr_lf>
Sent:  ATSW23,7,1,1<cr>      // Set PIO7 output high and store in flash
Reply:  OK<cr_lf>

```

Now you can communicate with the Bluetooth device with flow control turned off.

Other Examples

See the Bluetooth AT Commands Reference Guide for other examples:

- Multipoint Example Using the SocketWireless MTS2BTSMI or the Bluetooth Adapter MT2BTA – One Slave and Four Master Devices.
- Multipoint Example Using the SocketWireless MTS2BTSMI or the Bluetooth Adapter MT2BTA – One Master and Four Slave Devices.
- Repeater Example Using the SocketWireless MTS2BTSMI or the Bluetooth Adapter MT2BTA.

Changing Configuration

Parameters, such as the Bluetooth Name, Service Name, Class of Device, and Serial Port settings can be viewed and configured. This can be done locally through the serial port UART or from a remote Bluetooth RF link. To configure the SocketWireless Bluetooth device, the device must be in command mode by issuing **+++**.

You can use the developer board and the RS-232 cable to connect to a PC and pass ASCII characters through the terminal to the SocketWireless Bluetooth device. The communications settings should match the settings used when the SocketWireless Bluetooth device connects. For example, the defaults are:

```

9600bps
8 bits
No Parity
1 stop bit
Hardware flow control enabled.

```

Once you change these parameters, you have the option to store them permanently in the non-volatile memory. Run your favorite terminal emulator, HyperTerminal, or other program.

- Type **AT** on your screen and follow it with a carriage return **<cr_lf>**. You should see **"OK"** returned to you. This will verify that your cable and communications settings are correct. When the SocketWireless device is not connected to another Bluetooth device, you can type the AT commands directly into the SocketWireless' UART; e.g., you do not have to type **+++** to change from data mode to command mode.
- Now you can enter any of the AT commands discussed in the following sections. Follow these commands by **<cr_lf>**. Valid commands will return an **"OK"** or a valid response. Invalid commands will reply **ERROR**.
- To return to data mode, type **ATMD**. You can now pass or receive data from a remote connected Bluetooth device.

Notes:

- If you change communications parameter settings, remember to change your terminal or emulator communications settings to correspond to the newly created parameter settings.
- AT commands will not echo back to the terminal.

Index

- A**
- Activation procedures 38
 - Antenna Connector 34
 - AT Commands Reference Guides
 - SocketEthernet IP (MT100SEM-IP)..... 155
 - SocketModem (MT2492SMI)..... 149
 - SocketModem (MT5692SMI)..... 125
 - SocketModem (MT9234SMI)..... 108
 - SocketModem Cell & iCell CDMA (MTSMC-C1) 69
 - SocketModem Cell & iCell CDMA (MTSMC-EV2) 97
 - SocketModem Cell & iCell GPRS (MTSMC-G2) 57
 - SocketModem EDGE (MTSMC-E and E1) 79
 - SocketModem HSPA (MTSMC-H4) 85
 - SocketWireless Bluetooth (MTS2BTSMI)..... 170
 - SocketWireless Wi-Fi (MT810SWM-IP)..... 163
 - Auto-Discovery Manager 161
- B**
- Baud Rate Switches
 - SocketModem HSPA (MTSMC-H4) 95
 - SocketModem iCell (MTSMC-C1) 78
 - SocketModem iCell (MTSMC-EV2) 106
 - Block Diagram 20
 - Bluetooth Antenna Specifications 33
 - Bluetooth Changing Configurations 176
 - Bluetooth Example of a Master Discovery/Connection Sequence 175
 - Bluetooth Example of a Slave Command Sequence ... 175
 - Bluetooth RF Specifications 33
 - Bluetooth technology 170
 - Board Components 19
 - Brazil Regulatory Statement 50
- C**
- CDMA Antenna Specifications 31
 - CDMA RF Specifications 31
 - Cellular Approvals 38
 - China RoHS 54, 55
 - Coax Cable Specifications 34, 35
 - Connectivity Features 10
 - Country/Regional Codes 46
- D**
- DC Electrical Characteristics
 - SocketEthernet IP (MT100SEM-IP)..... 158
 - SocketModem (MT2492SMI)..... 152
 - SocketModem (MT5692SMI)..... 132
 - SocketModem (MT9234SMI)..... 112
 - SocketModem Cell & iCell CDMA (MTSMC-C1) 76
 - SocketModem Cell & iCell GPRS (MTSMC-G2) 65
 - SocketModem EDGE (MTSMC-E1) 83
 - SocketModem HSPA (MTSMC-H4) 89
 - SocketWireless Bluetooth (MTS2BTSMI)..... 173
 - Default Power Up Settings for Bluetooth 174
 - Default Power Up Settings for MT810SWM-IP 168
 - Design Considerations 16
 - Developer Board 18
 - Developer Board Schematics 21, 22, 23, 24, 25
- E**
- Electrical Characteristics
 - SocketModem iCell (MTSMC-EV2)..... 101
 - Electromagnetic Interference Considerations 17
 - Electrostatic Discharge Control 17
 - EMC Requirements for Industry Canada 47
 - EMC, Safety, and R&TTE Directive Compliance 47
- F**
- Fax Commands Reference Guides 11
 - FCC Part 15 Regulation 47
 - FCC Part 68 Regulation 48
 - Firmware Upgrade 26
 - Flash Programming Protocol 28
 - Flash Upgrade 26
 - Flash Upgrade Example 27
- G**
- GPS Antenna Specifications 32
 - GPS Features 37
 - GPS RF Specifications 32
 - GPS Technical Specifications 37
 - GSM RF Specifications 31
- H**
- Handling Precautions related to electrostatic discharge control 17
 - HSDPA/UMTS Antenna Specifications 32
 - HSDPA/UMTS RF Specifications 32
 - HSPA on Linux 94
- I**
- Internal Registers 118
 - International Modem Restrictions 47
 - Interrupt Sources and Reset Control Table
 - MT5692SMI 140
 - SocketModem (MT9234SMI) 120
- J**
- Japan Regulatory Statements 51
 - Jumper – 5V / 3.3V 19
- L**
- Label Example 38, 39
 - Label Example for Analog SocketModems 43
 - Labeling Requirements 41
 - Labeling Your Product 41
 - LED Interface
 - SocketEthernet IP (MT100SEM-IP) 159
 - SocketModem CDMA (MTSMC-C1) 77
 - SocketModem HSPA (MTSMC-H4) 92
 - SocketModem iCell (MTSMC-EV2)..... 105
 - SocketWireless Wi-Fi (MT810SWM-IP) 168
- M**
- Maintenance of Your Modem 45

Mechanical Drawings	
SocketEthernet IP (MT100SEM-IP).....	157
SocketModem (MT2492SMI).....	151
SocketModem (MT5692SMI).....	127, 128, 129, 130, 131
SocketModem (MT9234SMI).....	110, 111
SocketModem Cell & iCell CDMA (MTSMC-C1) .	72, 73, 74, 75
SocketModem Cell & iCell CDMA (MTSMC-EV2)	100
SocketModem Cell GPRS (MTSMC-G2).....	60, 62, 64
SocketModem EDGE (MTSMC-E1)	81, 82
SocketModem HSPA (MTSMC-H4)	88
SocketModem HSPA GPS (MTSMC-H4-GP).....	88
SocketModem HSPA USB (MTSMC-H4-U)	88
SocketModem iCell GPRS (MTSMC-G2).....	63
SocketWireless Bluetooth (MTS2BTSMI).....	172
SocketWireless Wi-Fi (MT810SWM-IP).....	165
SocketWireless Wi-Fi (MT810SWM-L-IP)	166
Microphone and Speaker for SocketModem MT5692SMI	
.....	148
Microphone Input for EDGE	84
Microphone Inputs for MTSMC-G2	66
N	
New Zealand Telecom Warning Notice.....	49
O	
Other Countries – Regulatory Statement	51
P	
Parallel Interface	
SocketModem (MT5692SMI).....	136
SocketModem (MT9234SMI).....	116
Parallel Interface Register Table	
SocketModem (MT5692SMI).....	137
SocketModem (MT9234SMI).....	118
Parallel Timing Requirements	
SocketModem (MT5692SMI).....	134
SocketModem (MT9234SMI).....	114
Parts	160
Parts for Analog SocketModems.....	40
PC Board Layout Guidelines.....	16
Pin-Out Specifications	
SocketModem iCell (MTSMC-EV2)	102
Pin-Out Specifications SocketModem HSPA (MTSMC-H4)	
.....	90
Power Measurements	
SocketEthernet IP (MT100SEM-IP).....	158
SocketModem (MT2492SMI).....	152
SocketModem (MT5692SMI).....	133
SocketModem Cell & iCell GPRS (MTSMC-G2)	65
SocketModem EDGE (MTSMC-E1)	83
SocketModem HSPA (MTSMC-H4)	91
SocketModem iCell (MTSMC-EV2).....	104
SocketWireless Bluetooth (MTS2BTSMI).....	173
Product Ordering Information	
SocketEthernet IP (MT100SEM-IP).....	155
SocketModem (MT2492SMI).....	149
SocketModem (MT5692SMI).....	124
SocketModem (MT9234SMI).....	108
SocketModem (MTSMC-EV2).....	96
SocketModem Cell & iCell CDMA (MTSMC-C1)	68
SocketModem Cell & iCell GPRS (MTSMC-G2)	57
SocketModem EDGE (MTSMC-E1).....	79
SocketModem HSPA (MTSMC-H4).....	85
SocketWireless Bluetooth (MTS2BTSMI)	170
SocketWireless Wi-Fi (MT810SWM-IP)	163
Programmable Baud Rates Table	
SocketModem (MT5692SMI)	145
SocketModem (MT9234SMI)	122
R	
Receiver Features for EDGE	84
Receiver Features for HSDPA.....	92
Reset	13, 115, 135
RF Interface	
MTSMC-G2.....	66
SocketModem CDMA (MTSMC-C1)	77
SocketModem EDGE (MTSMC-E1)	84
RF Safety	44
RoHS Compliance	53
S	
Safety Warning Telecom	45
South African Regulatory Statement	49
Speaker Output for EDGE	84
Stereo jack feed jumper.....	19
Switch Block	19
T	
Technical Specifications	
SocketEthernet IP (MT100SEM-IP)	156
SocketModem (MT2492SMI)	150
SocketModem (MT5692SMI)	126
SocketModem (MT9234SMI)	109
SocketModem Cell & iCell CDMA (MTSMC-C1).....	70
SocketModem Cell & iCell CDMA (MTSMC-EV2).....	98
SocketModem Cell & iCell GPRS (MTSMC-G2)	59
SocketModem EDGE (MTSMC-E1).....	80
SocketModem HSPA (MTSMC-H4)	86
SocketWireless Bluetooth (MTS2BTSMI)	171
SocketWireless Wi-Fi (MT810SWM-IP)	164
Telecom Approvals.....	46
Thailand Regulatory Statement	49
Tip and Ring Interface	
SocketModem (MT5692SMI)	146
SocketModem (MT9234SMI)	123
Transmitter Features for EDGE.....	84
Transmitter Features for HSDPA.....	92
U	
Universal Developer Kit contents.....	11
Universal Pin Descriptions.....	12
Universal Socket Design	10
W	
WEEE Directive	52
Wi-Fi Antenna Specifications.....	33
Wi-Fi RF Specifications	33
X	
XMODEM Serial Port Upgrade	27