

FCC TEST REPORT

FCC ID : ATL-ISP245A
Applicant : iLUV Creative Technology
Address : Harbor Park Drive, Port Washington, NY11050, USA

Equipment Under Test (EUT) :

Product Name : Bluetooth Speaker
 Model No. : iSP245,iSP245SIL,iSP245BLK,iSP246
 Brand Name : iLuv

Standards : FCC CFR47 Part 15 Section 15.247:2010

Date of Test : May 19 ~ May 31, 2012

Date of Issue : May 31, 2012

Tested By : Zero Zhou / Engineer



Reviewed By : Philo zhong / Manager



Test Result	: PASS
--------------------	---------------

Prepared By:**Waltek Services (Shenzhen) Co., Ltd.**

12B, West Tower, Aidi Building, No.5003, Binhe Road, Futian District, Shenzhen, Guangdong,
China

Tel :+86-755-83551033

Fax:+86-755-83552400

- ✧ The sample detailed above has been tested to the requirements of Council Directives ANSI C63.4:2003. The test results have been reviewed against the Directives above and found to meet their essential requirements.

2 Test Summary

Test Items	Test Requirement	Result
Conducted Emissions (150kHz to 30MHz)	15.207	PASS
Radiated Spurious Emissions (26MHz to 25GHz)	15.205(a) 15.209 15.247(d)	PASS
20dB Bandwidth	15.247(a)(1)	PASS
Maximum Peak Output Power	15.247(b)(1)	PASS
Frequency Separation	15.247(a)(1)	PASS
Number of Hopping Frequency	15.247(a)(1)(iii)	PASS
Dwell time	15.247(a)(1)(iii)	PASS
Maximum Permissible Exposure (Exposure of Humans to RF Fields)	1.1307(b)(1)	PASS

The results shown in this test report refer only to the sample(s) tested , This Test report cannot be reproduced, except in full, without prior written permission of the company.

3 Contents

	Page
1 COVER PAGE.....	1
2 TEST SUMMARY	2
3 CONTENTS.....	3
4 GENERAL INFORMATION	5
4.1 CLIENT INFORMATION.....	5
4.2 GENERAL DESCRIPTION OF E.U.T.....	5
4.3 DETAILS OF E.U.T.....	5
4.4 DESCRIPTION OF SUPPORT UNITS.....	7
4.5 STANDARDS APPLICABLE FOR TESTING	7
4.6 TEST FACILITY	7
4.7 TEST LOCATION	7
4.8 MEASUREMENT UNCERTAINTY	7
5 EQUIPMENT USED DURING TEST	8
6 CONDUCTED EMISSION	9
6.1 E.U.T. OPERATION.....	9
6.2 EUT SETUP	10
6.3 CONDUCTED EMISSION TEST RESULT	10
6.4 PHOTOGRAPH – CONDUCTED EMISSION TEST SETUP	13
7 RADIATED SPURIOUS EMISSIONS.....	14
7.1 EUT OPERATION :	14
7.2 TEST SETUP.....	15
7.3 SPECTRUM ANALYZER SETUP	16
7.4 TEST PROCEDURE.....	17
7.5 CORRECTED AMPLITUDE & MARGIN CALCULATION.....	17
7.6 SUMMARY OF TEST RESULTS	17
7.7 PHOTOGRAPH – RADIATION SPURIOUS EMISSION TEST SETUP	27
8 BAND EDGE MEASUREMENTS.....	28
9 20 DB BANDWIDTH MEASUREMENT.....	33
9.1 TEST PROCEDURE:.....	33
9.2 TEST RESULT:	33
10 MAXIMUM PEAK OUTPUT POWER	35
10.1 TEST PROCEDURE:.....	35
10.2 TEST RESULT:.....	35
11 HOPPING CHANNEL SEPARATION.....	36
11.1 TEST PROCEDURE:.....	36
11.2 TEST RESULT:.....	36
12 NUMBER OF HOPPING FREQUENCY	39
12.1 TEST PROCEDURE:.....	39
12.2 TEST RESULT:.....	39
13 DWELL TIME	40
13.1 TEST PROCEDURE:.....	40
13.2 TEST RESULT:.....	40
14 ANTENNA REQUIREMENT	47
15 RF EXPOSURE	48

The results shown in this test report refer only to the sample(s) tested , This Test report cannot be reproduced, except in full, without prior written permission of the company.

15.1 REQUIMENTS: 48
15.2 MEASUREMENT RESULT: 48
16 PHOTOGRAPHS - CONSTRUCTIONAL DETAILS..... 49
16.1 PRODUCT VIEW 49
16.2 EUT – APPEARANCE VIEW 49
16.3 EUT – OPEN VIEW 50
16.4 EUT – PCB1 VIEW 51
16.5 MODULE – PCB VIEW 52
16.6 EUT – PCB2 VIEW 52
17 FCC LABEL..... 54

4 General Information

4.1 Client Information

Applicant : iLUV Creative Technology
Address of Applicant : Harbor Park Drive, Port Washington, NY11050, USA

Manufacturer : Wonders Technology Co., Ltd.
Address of Manufacturer : Doss Industrial Zone, Qiping Kengdu Industrial ARE Guihua Village, Guanlan Town, Baoan District, Shenzhen, China.

4.2 General Description of E.U.T.

Product Name : Bluetooth Speaker
Model No. : iSP245,iSP245SIL,iSP245BLK,iSP246
Difference Description : All models are exactly the same except for different color and appearance.

4.3 Details of E.U.T.

Technical Data : Internal Li-ion Battery: 3.7V
 Charging Voltage: DC 5.0V
Operation Frequency : 2402MHz ~ 2480MHz
Bluetooth : version 2.0(model:F-3088)
Antenna Gain : 0dBi(PCB printed antenna)

Channel List

Channel No.	Frequency (MHz)	Channel No.	Frequency (MHz)	Channel No.	Frequency (MHz)
1	2402	28	2429	55	2456
2	2403	29	2430	56	2457
3	2404	30	2431	57	2458
4	2405	31	2432	58	2459
5	2406	32	2433	59	2460
6	2407	33	2434	60	2461
7	2408	34	2435	61	2462
8	2409	35	2436	62	2463
9	2410	36	2437	63	2464
10	2411	37	2438	64	2465
11	2412	38	2439	65	2466
12	2413	39	2440	66	2467
13	2414	40	2441	67	2468
14	2415	41	2442	68	2469

The results shown in this test report refer only to the sample(s) tested , This Test report cannot be reproduced, except in full, without prior written permission of the company.

15	2416	42	2443	69	2470
16	2417	43	2444	70	2471
17	2418	44	2445	71	2472
18	2419	45	2446	72	2473
19	2420	46	2447	73	2474
20	2421	47	2448	74	2475
21	2422	48	2449	75	2476
22	2423	49	2450	76	2477
23	2424	50	2451	77	2478
24	2425	51	2452	78	2479
25	2426	52	2453	79	2480
26	2427	53	2454	-	-
27	2428	54	2455	-	-

The results shown in this test report refer only to the sample(s) tested , This Test report cannot be reproduced, except in full, without prior written permission of the company.

4.4 Description of Support Units

The EUT has been tested as an independent unit.

4.5 Standards Applicable for Testing

The customer requested FCC tests for a Bluetooth Speaker. The standards used were FCC CFR47 Part 15 Section 15.203, Section 15.207, Section 15.209 and Section 15.247.

4.6 Test Facility

The test facility has a test site registered with the following organizations:

- **IC – Registration No.: IC7760A**

Waltek Services(Shenzhen) Co., Ltd. has been registered and fully described in a report filed with the Industry Canada. The acceptance letter from the Industry Canada is maintained in our files. Registration 7760A, August 3, 2010.

- **FCC – Registration No.: 880581**

Waltek Services(Shenzhen) Co., Ltd. EMC Laboratory has been registered and fully described in a report filed with the (FCC) Federal Communications Commission. The acceptance letter from the FCC is maintained in our files. Registration 880581, May 26, 2011.

4.7 Test Location

All the tests were performed at:

Waltek Services(Shenzhen) Co., Ltd. at 1/F, Fukangtai Building, West Baima Rd., Songgang Street, Baoan District, Shenzhen, China

4.8 Measurement Uncertainty

Parameter	Uncertainty
Radio Frequency	$\pm 1 \times 10^{-6}$
RF Power	± 1.0 dB
RF Power Density	± 2.2 dB
Radiated Spurious Emissions test	± 5.03 dB (Bilog antenna 30M~1000MHz)
	± 4.74 dB (Horn antenna 1000M~25000MHz)
Conducted Spurious Emissions test	± 2.2 dB

The results shown in this test report refer only to the sample(s) tested , This Test report cannot be reproduced, except in full, without prior written permission of the company.

5 Equipment Used during Test

Equipment Name	Manufacturer Model	Equipment No	Internal No	Specification	Cal. Date	Due Date	Uncertainty
EMC Analyzer	Agilent/ E7405A	MY45114943	W2008001	9k-26.5GHz	Aug. 2, 2011	Aug. 1, 2012	±1dB
Active Loop Antenna	Beijing Dazhi / ZN30900A	-	-	9kHz-30MHz	Aug. 2, 2011	Aug. 1, 2012	±1Db
Trilog Broadband Antenne	SCHWARZECK MESS-ELEKTROM / VULB9163	336	W2008002	25-3000 MHz	Aug. 2, 2011	Aug. 1, 2012	±1dB
Broad-band Horn Antenna	SCHWARZECK MESS-ELEKTROM / BBHA 9120D(1201)	667	W2008003	1-18GHz	Aug. 2, 2011	Aug. 1, 2012	f < 10 GHz : ±1dB 10GHz < f < 18 GHz : ±1.5dB
Broadband Preamplifier	SCHWARZECK MESS-ELEKTROM / BBV 9718	9718-148	W2008004	0.5-18GHz	Aug. 2, 2011	Aug. 1, 2012	±1.2dB
10m Coaxial Cable with N-male Connectors	SCHWARZECK MESS-ELEKTROM / AK 9515 H	-	-	-	Aug. 2, 2011	Aug. 1, 2012	-
10m 50 Ohm Coaxial Cable	SCHWARZECK MESS-ELEKTROM / AK 9513	-	-	-	Aug. 2, 2011	Aug. 1, 2012	-
Positioning Controller	C&C LAB/ CC-C-IF	-	-	-	Aug. 2, 2011	Aug. 1, 2012	-
Color Monitor	SUNSPON/ SP-14C	-	-	-	Aug. 2, 2011	Aug. 1, 2012	-
Test Receiver	ROHDE&SCHWARZ/ ESPI	101155	W2005001	9k-3GHz	Aug. 2, 2011	Aug. 1, 2012	±1dB
Two-Line V-Network	ROHDE&SCHWARZ/ ENV216	100115	W2005002	50Ω/50μH	Aug. 2, 2011	Aug. 1, 2012	±10%
RF Generator	TESEQ GmbH/ NSG4070	25781	W2008008	Fraq-range : 9K-1GHz RF voltage : -60 dBm-+10dBm	Aug. 2, 2011	Aug. 1, 2012	Power_freq distinguish0.1Hz RFelectricity distinguish 0.1B
MP3 Player	Ipod Player/A1285	5K85004U3R0	-	-	Aug. 2, 2011	Aug. 1, 2012	±0.5dB

The results shown in this test report refer only to the sample(s) tested, This Test report cannot be reproduced, except in full, without prior written permission of the company.

6 Conducted Emission

Test Requirement:	FCC CFR 47 Part 15 Section 15.207
Test Method:	ANSI C63.4:2003
Test Result:	PASS
Frequency Range:	150kHz to 30MHz
Class:	Class B
Limit:	66-56 dB μ V between 0.15MHz & 0.5MHz 56 dB μ V between 0.5MHz & 5MHz 60 dB μ V between 5MHz & 30MHz
Detector:	Peak for pre-scan (9kHz Resolution Bandwidth) Quasi-Peak & Average if maximised peak within 6dB of Average Limit

6.1 E.U.T. Operation

Operating Environment:

Temperature:	25.5 °C
Humidity:	51 % RH
Atmospheric Pressure:	1012 mbar

EUT Operation:

The EUT was tested in charging mode.

The EUT was tested according to ANSI C63.4:2003. The frequency spectrum from 150kHz to 30MHz was investigated.

The maximised peak emissions from the EUT was scanned and measured for both the Live and Neutral Lines. Quasi-peak & average measurements were performed if peak emissions were within 6dB of the average limit line.

6.2 EUT Setup

The conducted emission tests were performed using the setup accordance with the ANSI C63.4:2003, The specification used in this report was the FCC Part15.207 limits.

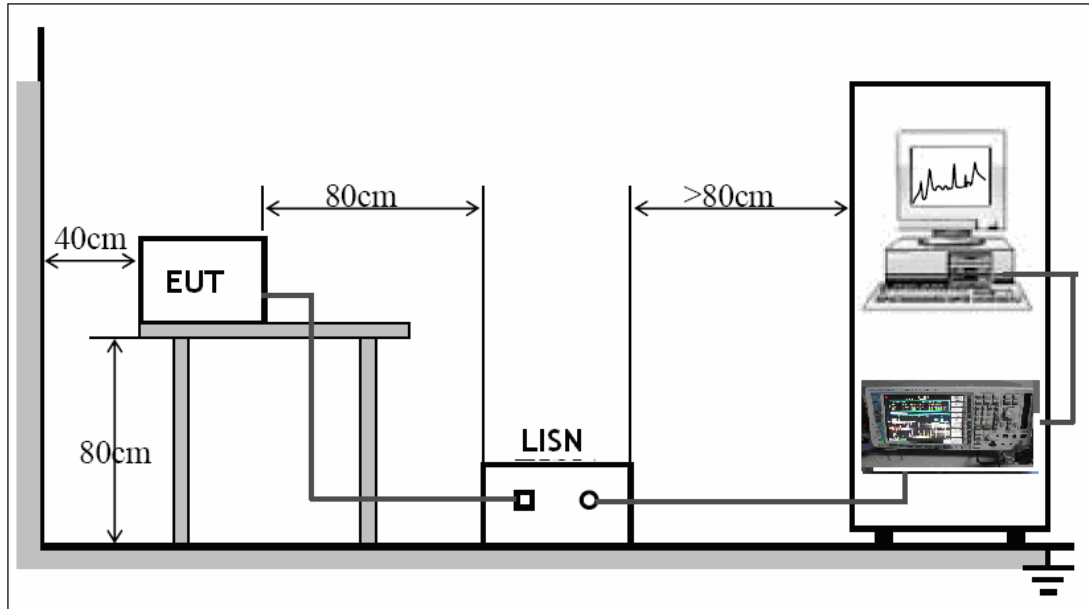

The EUT was placed on the test table in shielding room

6.3 Conducted Emission Test Result

An initial pre-scan was performed on the live and neutral lines.

Live line:

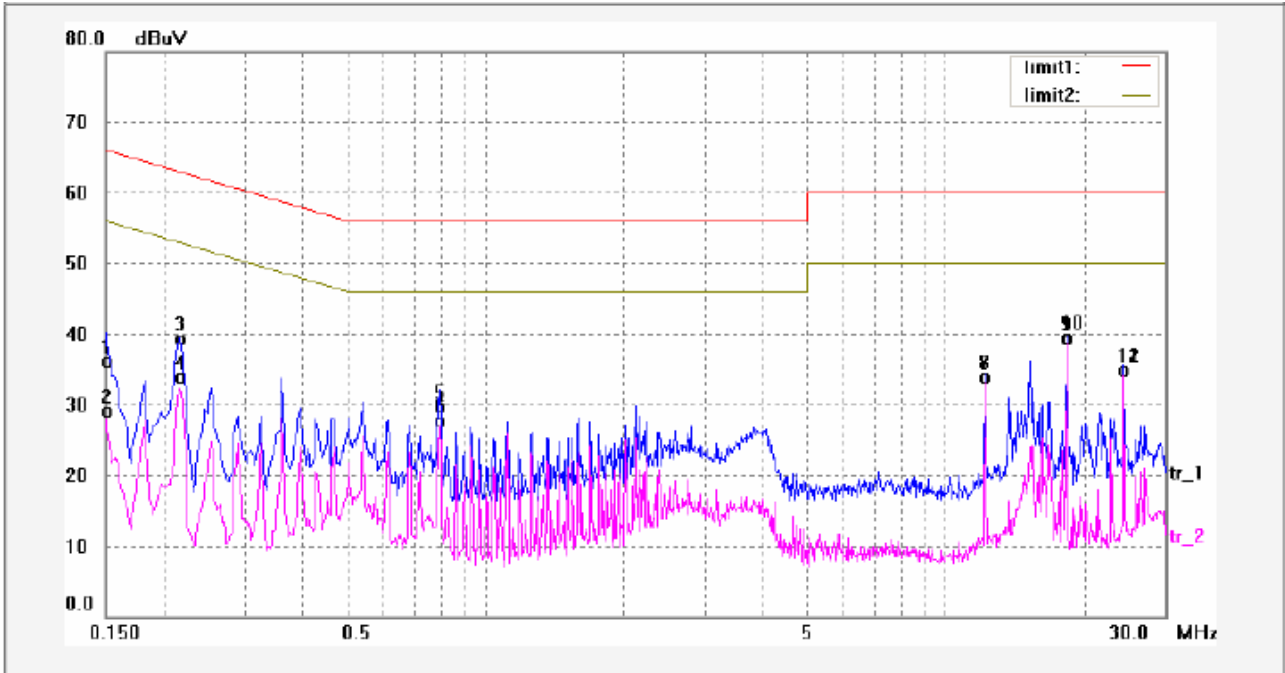

No.	Freq. (MHz)	Reading (dBuV)	Factor (dB)	Result (dBuV)	Limit dBuV	Margin (dB)	Detector	Remark
1	0.1500	24.93	10.35	35.28	65.99	-30.71	QP	
2	0.1500	17.96	10.35	28.31	55.99	-27.68	AVG	
3	0.2180	28.09	10.35	38.44	62.89	-24.45	QP	
4	0.2180	22.67	10.35	33.02	52.89	-19.87	AVG	
5	0.7980	18.46	10.36	28.82	56.00	-27.18	QP	
6	0.7980	16.61	10.36	26.97	46.00	-19.03	AVG	
7	12.2460	22.62	10.46	33.08	60.00	-26.92	QP	
8	12.2460	22.58	10.46	33.04	50.00	-16.96	AVG	
9	18.3700	28.12	10.45	38.57	60.00	-21.43	QP	
10	18.3700	28.16	10.45	38.61	50.00	-11.39	AVG	
11	24.4940	23.73	10.44	34.17	60.00	-25.83	QP	
12	24.4940	23.57	10.44	34.01	50.00	-15.99	AVG	

The results shown in this test report refer only to the sample(s) tested , This Test report cannot be reproduced, except in full, without prior written permission of the company.

Neutral line:

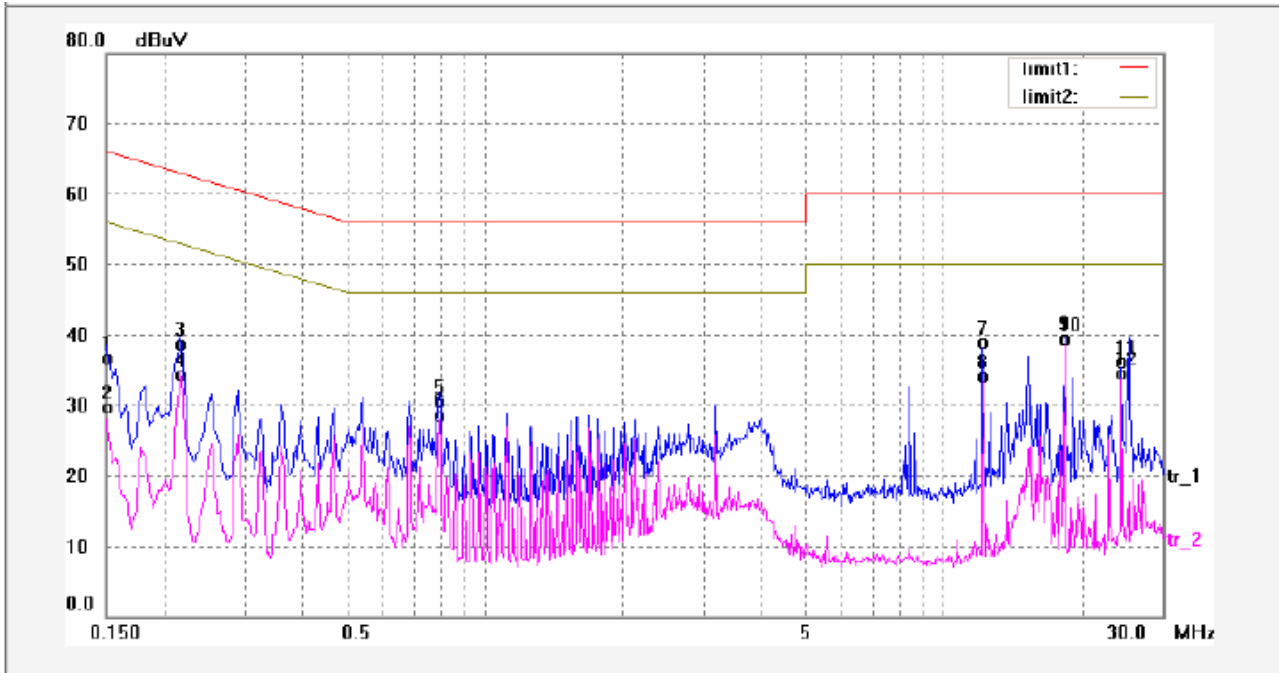

No.	Freq. (MHz)	Reading (dBuV)	Factor (dB)	Result (dBuV)	Limit dBuV	Margin (dB)	Detector	Remark
1	0.1500	25.60	10.35	35.95	65.99	-30.04	QP	
2	0.1500	18.46	10.35	28.81	55.99	-27.18	AVG	
3	0.2180	27.62	10.35	37.97	62.89	-24.92	QP	
4	0.2180	23.11	10.35	33.46	52.89	-19.43	AVG	
5	0.7980	19.43	10.36	29.79	56.00	-26.21	QP	
6	0.7980	17.39	10.36	27.75	46.00	-18.25	AVG	
7	12.2460	27.70	10.46	38.16	60.00	-21.84	QP	
8	12.2460	22.78	10.46	33.24	50.00	-16.76	AVG	
9	18.3700	28.18	10.45	38.63	60.00	-21.37	QP	
10	18.3700	28.15	10.45	38.60	50.00	-11.40	AVG	
11	24.4940	24.79	10.44	35.23	60.00	-24.77	QP	
12	24.4940	23.25	10.44	33.69	50.00	-16.31	AVG	

The results shown in this test report refer only to the sample(s) tested , This Test report cannot be reproduced, except in full, without prior written permission of the company.

6.4 Photograph – Conducted Emission Test Setup



The results shown in this test report refer only to the sample(s) tested , This Test report cannot be reproduced, except in full, without prior written permission of the company.

WALTEK SERVICES

Reference No.: WT12052983-D-S-F

7 Radiated Spurious Emissions

Test Requirement:	FCC CFR47 Part 15 Section 15.209 & 15.247
Test Method:	Complies with DA 00-705
Test Result:	PASS
Frequency Range:	25MHz to 25GHz
Measurement Distance:	3m
15.209 Limit:	40.0 dBuV/m between 30MHz & 88MHz 43.5 dBuV/m between 88MHz & 216MHz 46.0 dBuV/m between 216MHz & 960MHz 54.0 dBuV/m above 960MHz
15.247 (d) Limit:	(d) In any 100 kHz bandwidth outside the frequency band in which the spread spectrum or digitally modulated intentional radiator is operating. The radio frequency power that is produced by the intentional radiator shall be at least 20 dB below that in the 100 kHz bandwidth within the band that Contains the highest level of the desired power, based on either an RF conducted or a radiated measurement, provided the transmitter demonstrates compliance with the peak conducted power limits.
Test mode:	The EUT was tested in continuously Transmit mode.

7.1 EUT Operation :

Operating Environment:

Temperature:	25.5 °C
Humidity:	51 % RH
Atmospheric Pressure:	1012 mbar

7.2 Test Setup

The radiated emission tests were performed in the 3m Semi- Anechoic Chamber test site, using the setup accordance with the ANSI C63.4:2003.

Since the lowest oscillator is 26MHz in this device,so the spectrum was be investigated from 26MHz to 25GHz.

The test setup for emission measurement below 30MHz.

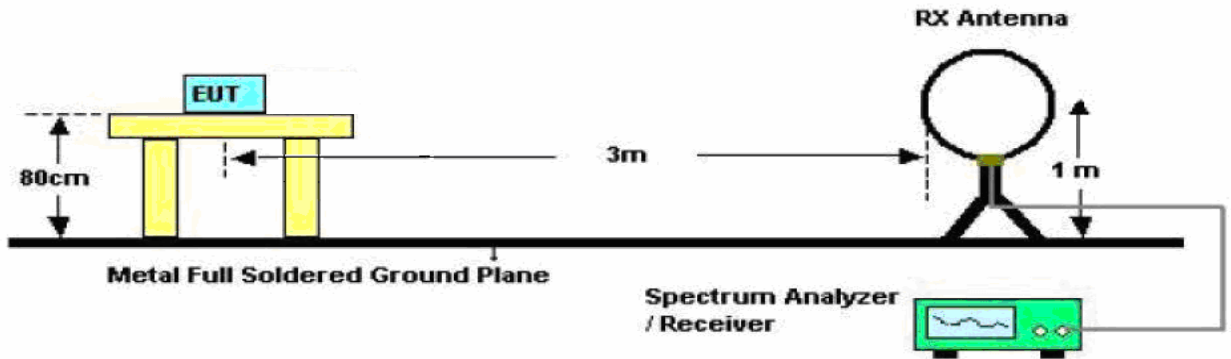

The diagram below shows the test setup that is utilized to make the measurements for emission from 25 MHz to 1 GHz Emissions.

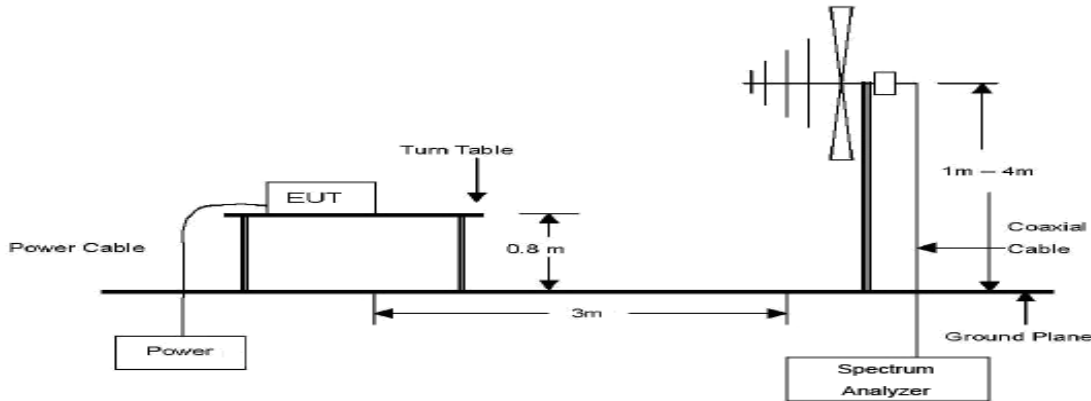

The diagram below shows the test setup that is utilized to make the measurements for emission from 1 GHz to 25 GHz Emissions.

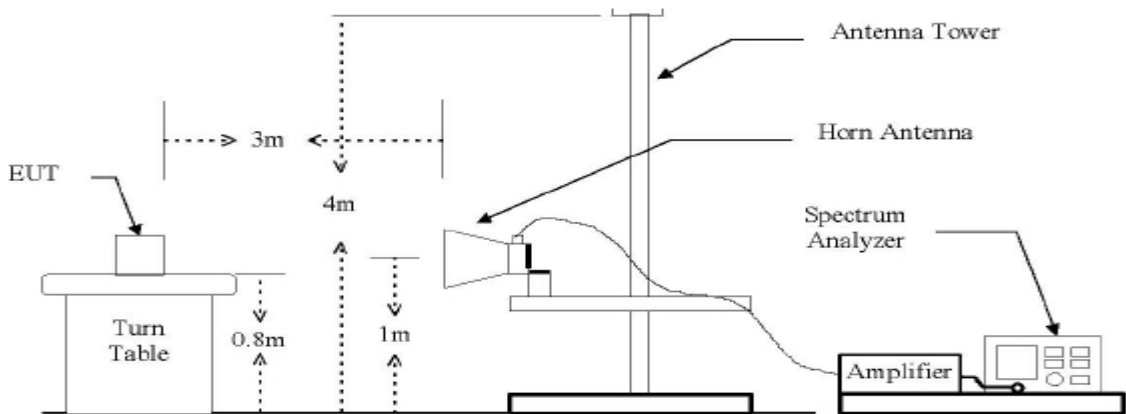

The results shown in this test report refer only to the sample(s) tested , This Test report cannot be reproduced, except in full, without prior written permission of the company.

7.3 Spectrum Analyzer Setup

According to FCC Part15 Rules, the system was tested 25MHz to 25000MHz.

Below 30MHz

Start Frequency	9kHz
Stop Frequency.....	30MHz
Sweep Speed.....	Auto
IF Bandwidth.....	10KHz
Video Bandwidth.....	10KHz
Resolution Bandwidth.....	10KHz

25MHz ~ 1GHz

Start Frequency	25 MHz
Stop Frequency.....	1000MHz
Sweep Speed.....	Auto
IF Bandwidth.....	120 KHz
Video Bandwidth.....	100KHz
Quasi-Peak Adapter Bandwidth	120 KHz
Quasi-Peak Adapter Mode	Normal
Resolution Bandwidth	100KHz

Above 1GHz

Start Frequency	1000 MHz
Stop Frequency.....	25000MHz
Sweep Speed.....	Auto
IF Bandwidth.....	120 KHz
Video Bandwidth.....	3MHz
Quasi-Peak Adapter Bandwidth	120 KHz
Quasi-Peak Adapter Mode	Normal
Resolution Bandwidth	1MHz

7.4 Test Procedure

1. The EUT is placed on a turntable, which is 0.8m above ground plane.
2. The turntable shall be rotated for 360 degrees to determine the position of maximum emission level.
3. EUT is set 3m away from the receiving antenna, which is moved from 1m to 4m to find out the maximum emissions.
4. Maximum procedure was performed on the six highest emissions to ensure EUT compliance.
5. And also, each emission was to be maximized by changing the polarization of receiving antenna both horizontal and vertical.
6. Repeat above procedures until the measurements for all frequencies are complete.
7. The radiation measurements are tested under 3-axes(X,Y,Z) position(X denotes lying on the table, Y denotes side stand and Z denotes vertical stand), After pre-test, It was found that the worse radiation emission was get at the X position. So the data shown was the X position only.

7.5 Corrected Amplitude & Margin Calculation

The Corrected Amplitude is calculated by adding the Antenna Factor and Cable Factor, and subtracting the Amplifier Gain from the Amplitude reading. The basic equation is as follows:

$$\text{Corr. Ampl.} = \text{Indicated Reading} + \text{Antenna Factor} + \text{Cable Factor} - \text{Amplifier Gain}$$

The “**Margin**” column of the following data tables indicates the degree of compliance with the applicable limit. For example, a margin of -7dB means the emission is 7dB below the maximum limit for Class B. The equation for margin calculation is as follows:

$$\text{Margin} = \text{Corr. Ampl.} - \text{Limit}$$

7.6 Summary of Test Results

According to the data in this section, the EUT complied with the FCC CFR47 Part 15 Section 15.209 & 15.247 standards.

Test mode: continuously receive mode

Remark: the EUT was pretested at the high, middle and low channel, and the worse case was the middle Channel, so the data show was the low channel only. Because the emissions below 30MHz are more than 20dB below the limit, the data is not show in the report.

Test Frequency : 30MHz ~ 1000MHz

Antenna polarization: Vertical

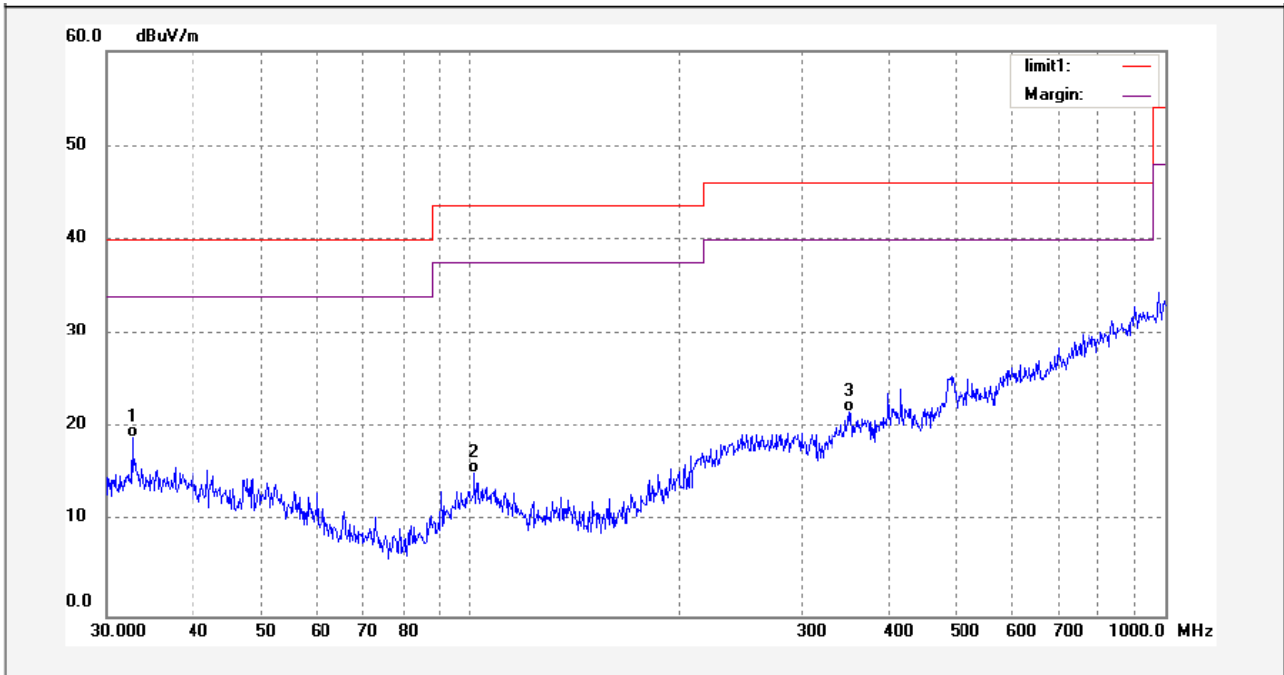

No.	Freq. (MHz)	Reading (dBuV/m)	Factor (dB)	Result (dBuV/m)	Limit (dBuV/m)	Margin (dB)	Detector	Remark
1	32.6395	2.35	16.58	18.93	40.00	-21.07	QP	
2	101.5358	1.12	14.06	15.18	43.50	-28.32	QP	
3	350.9722	1.48	20.19	21.67	46.00	-24.33	QP	

The results shown in this test report refer only to the sample(s) tested , This Test report cannot be reproduced, except in full, without prior written permission of the company.

Antenna polarization: Horizontal

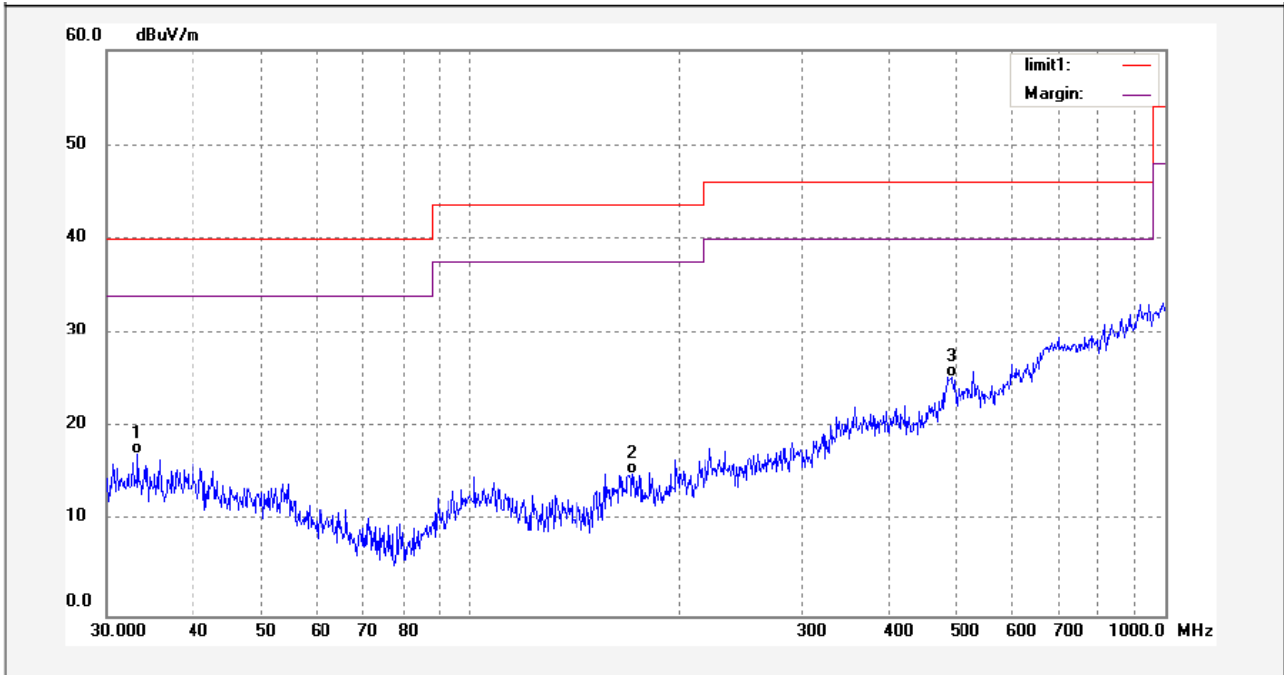

No.	Freq. (MHz)	Reading (dBuV/m)	Factor (dB)	Result (dBuV/m)	Limit (dBuV/m)	Margin (dB)	Detector	Remark
1	33.2180	0.55	16.56	17.11	40.00	-22.89	QP	
2	171.3890	2.97	12.15	15.12	43.50	-28.38	QP	
3	491.7700	0.04	25.29	25.33	46.00	-20.67	QP	

The results shown in this test report refer only to the sample(s) tested , This Test report cannot be reproduced, except in full, without prior written permission of the company.

Test Frequency: Above 1GHz radiation test data:

Remark: No any emissions were found from 18GHz to 25 GHz, So the radiated emissions from 18GHz to 25GHz were not record.

Antenna polarization: Vertical

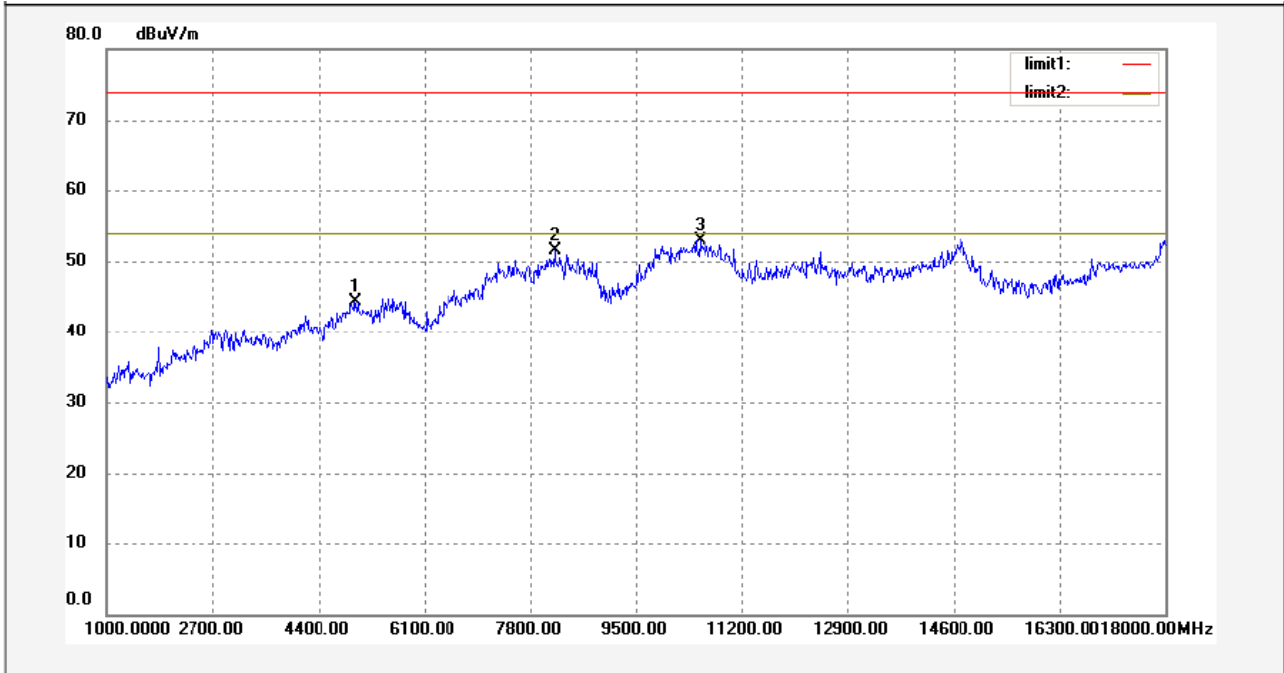

No.	Freq. (MHz)	Reading (dBuV/m)	Factor (dB)	Result (dBuV/m)	Limit (dBuV/m)	Margin (dB)	Detector	Remark
1	4985.972	39.15	5.12	44.27	74.00	-29.73	peak	
2	8188.377	36.98	14.58	51.56	74.00	-22.44	peak	
3	10522.044	34.45	18.52	52.97	74.00	-21.03	peak	

The results shown in this test report refer only to the sample(s) tested , This Test report cannot be reproduced, except in full, without prior written permission of the company.

Antenna polarization: Horizontal

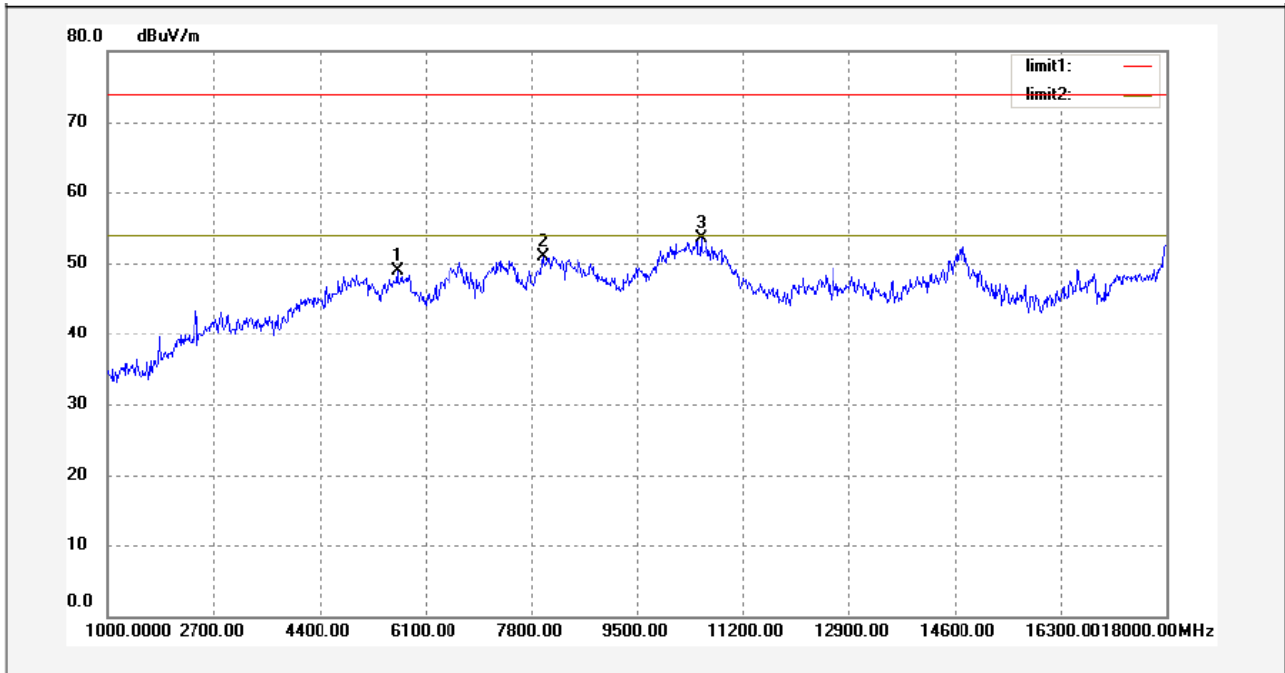

No.	Freq. (MHz)	Reading (dBuV/m)	Factor (dB)	Result (dBuV/m)	Limit (dBuV/m)	Margin (dB)	Detector	Remark
1	5650.301	39.56	9.37	48.93	74.00	-25.07	peak	
2	7983.968	32.74	18.16	50.90	74.00	-23.10	peak	
3	10522.044	32.60	20.84	53.44	74.00	-20.56	peak	

The results shown in this test report refer only to the sample(s) tested , This Test report cannot be reproduced, except in full, without prior written permission of the company.

Test mode: continuously transmit mode

Remark: The pre-test was performed in continuously transmit mode and normal link mode, and the continuously transmit mode was pretested at the high, middle and low channel. The worst mode is normal link mode, so the data show was that mode's only. Because the emissions below 30MHz are more than 20dB below the limit, the data do not show in the report.

Test Frequency : 30MHz ~ 1000MHz

Antenna polarization: Vertical

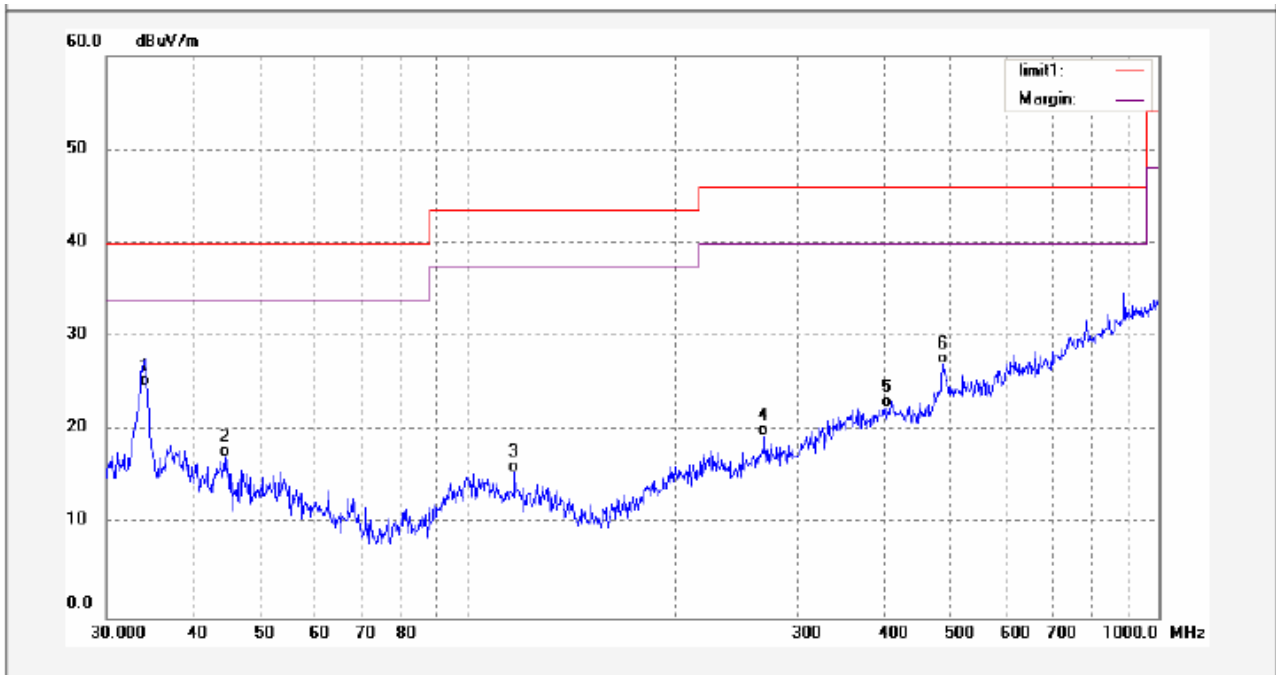

No.	Freq. (MHz)	Reading (dBuV/m)	Factor (dB)	Result (dBuV/m)	Limit (dBuV/m)	Margin (dB)	Detector	Remark
1	34.0451	8.13	16.53	24.66	40.00	-15.34	QP	
2	44.4657	2.34	14.87	17.21	40.00	-22.79	QP	
3	116.8574	3.19	12.35	15.54	43.50	-27.96	QP	
4	268.7212	2.75	16.70	19.45	46.00	-26.55	QP	
5	405.3553	1.27	21.21	22.48	46.00	-23.52	QP	
6	488.3263	1.86	25.25	27.11	46.00	-18.89	QP	

The results shown in this test report refer only to the sample(s) tested , This Test report cannot be reproduced, except in full, without prior written permission of the company.

Antenna polarization: Horizontal

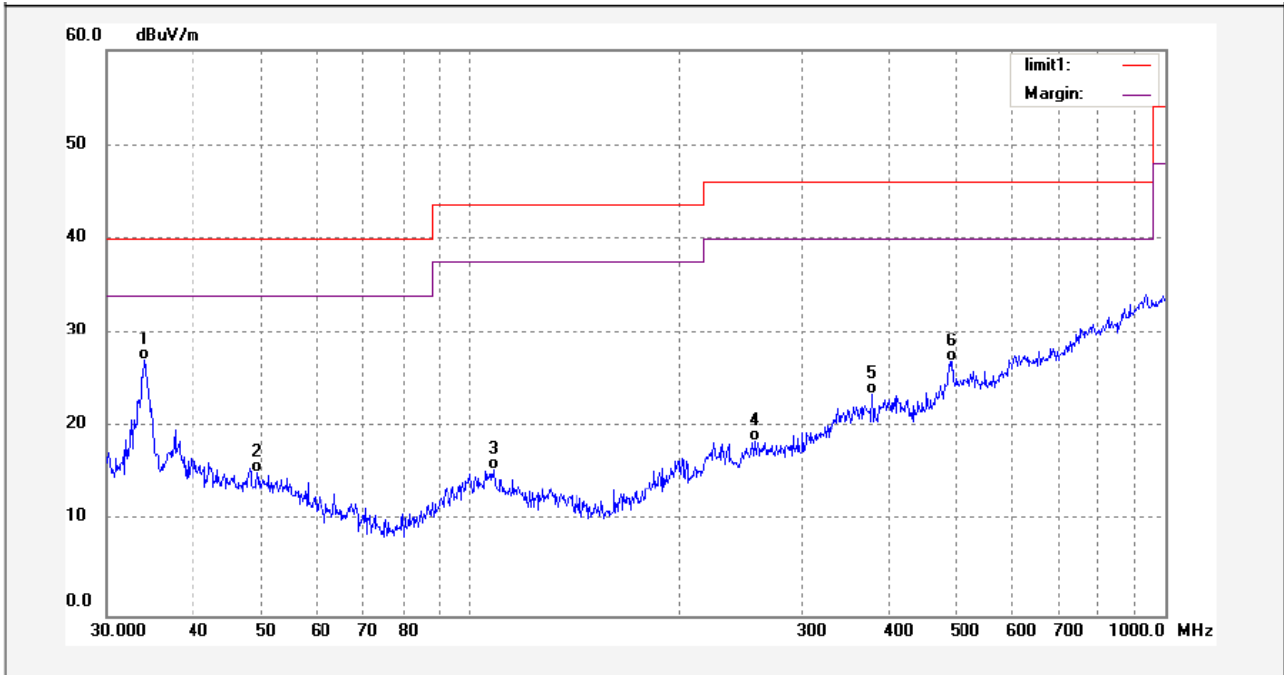

No.	Freq. (MHz)	Reading (dBuV/m)	Factor (dB)	Result (dBuV/m)	Limit (dBuV/m)	Margin (dB)	Detector	Remark
1	33.9256	10.57	16.54	27.11	40.00	-12.89	QP	
2	49.4087	0.63	14.60	15.23	40.00	-24.77	QP	
3	108.1648	1.55	13.93	15.48	43.50	-28.02	QP	
4	256.7230	2.47	16.09	18.56	46.00	-27.44	QP	
5	379.1780	3.50	20.05	23.55	46.00	-22.45	QP	
6	493.5009	2.15	24.83	26.98	46.00	-19.02	QP	

The results shown in this test report refer only to the sample(s) tested , This Test report cannot be reproduced, except in full, without prior written permission of the company.

Test Frequency: 1GHz ~ 25GHz

And the below is the Fundamental and Harmonic

Frequency (MHz)	Detector	Antenna Polarization	Emission Level (dBuV/m)	Limit (dBuV/m)	Margin (dB)	Antenna Height (m)	Turntable Angle (°)
Low frequency							
2402.00	AV	Vertical	95.37		(Fund.)	1.2	80
4804.00	AV	Vertical	38.43	54.00	-15.57	1.3	125
7206.00	AV	Vertical	39.22	54.00	-14.78	1.4	150
9608.00	AV	Vertical	35.64	54.00	-18.36	1.6	140
12010.00	AV	Vertical	33.23	54.00	-20.77	1.9	155
14412.00	AV	Vertical	35.24	54.00	-18.76	1.1	180
16814.00	AV	Vertical	34.49	54.00	-19.51	1.7	140
19216.00	AV	Vertical	29.41	54.00	-24.59	1.6	150
21618.00	AV	Vertical	26.65	54.00	-27.35	1.5	0
24020.00	AV	Vertical	29.73	54.00	-24.27	1.0	130
2402.00	AV	Horizontal	88.12		(Fund.)	1.5	50
4804.00	AV	Horizontal	35.32	54.00	-18.68	1.4	190
7206.00	AV	Horizontal	33.65	54.00	-20.35	1.5	70
9608.00	AV	Horizontal	36.20	54.00	-17.80	1.3	180
12010.00	AV	Horizontal	34.44	54.00	-19.56	1.4	90
14412.00	AV	Horizontal	31.29	54.00	-22.71	1.0	200
16814.00	AV	Horizontal	34.10	54.00	-19.90	1.8	120
19216.00	AV	Horizontal	26.61	54.00	-27.39	1.5	160
21618.00	AV	Horizontal	27.55	54.00	-26.45	1.2	140
24020.00	AV	Horizontal	26.17	54.00	-27.83	1.6	100
2402.00	PK	Vertical	106.17		(Fund.)	1.4	0
4804.00	PK	Vertical	57.28	74.00	-16.72	1.6	130
7206.00	PK	Vertical	58.22	74.00	-15.78	1.9	140
9608.00	PK	Vertical	54.95	74.00	-19.05	1.1	250
12010.00	PK	Vertical	51.31	74.00	-22.69	1.2	70
14412.00	PK	Vertical	52.60	74.00	-21.40	1.3	140
16814.00	PK	Vertical	49.41	74.00	-24.59	1.3	165
19216.00	PK	Vertical	47.69	74.00	-26.31	1.0	200
21618.00	PK	Vertical	45.47	74.00	-28.53	2.0	80
24020.00	PK	Vertical	46.62	74.00	-27.38	1.1	150
2402.00	PK	Horizontal	98.33		(Fund.)	1.8	100
4804.00	PK	Horizontal	55.59	74.00	-18.41	1.9	180
7206.00	PK	Horizontal	53.34	74.00	-20.66	1.7	60
9608.00	PK	Horizontal	50.45	74.00	-23.55	1.0	70
12010.00	PK	Horizontal	52.43	74.00	-21.57	1.5	185
14412.00	PK	Horizontal	47.34	74.00	-26.66	1.2	70
16814.00	PK	Horizontal	53.44	74.00	-20.56	1.8	190
19216.00	PK	Horizontal	45.29	74.00	-28.71	1.6	140

The results shown in this test report refer only to the sample(s) tested , This Test report cannot be reproduced, except in full, without prior written permission of the company.

21618.00	PK	Horizontal	46.62	74.00	-27.38	1.1	150
24020.00	PK	Horizontal	48.39	74.00	-25.61	1.7	150
Middle frequency							
2441.00	AV	Vertical	95.52		(Fund.)	1.5	40
4882.00	AV	Vertical	40.95	54.00	-13.05	1.7	170
7323.00	AV	Vertical	39.16	54.00	-14.84	1.0	120
9764.00	AV	Vertical	35.07	54.00	-18.93	1.0	80
12205.00	AV	Vertical	39.66	54.00	-14.34	1.5	20
14646.00	AV	Vertical	33.48	54.00	-20.52	1.2	210
17087.00	AV	Vertical	35.28	54.00	-18.72	1.5	40
19528.00	AV	Vertical	32.07	54.00	-21.93	1.6	90
21969.00	AV	Vertical	30.20	54.00	-23.80	1.7	180
24410.00	AV	Vertical	34.29	54.00	-19.71	1.0	160
2441.00	AV	Horizontal	88.66		(Fund.)	1.4	170
4882.00	AV	Horizontal	37.42	54.00	-16.58	1.8	160
7323.00	AV	Horizontal	38.63	54.00	-15.37	1.5	280
9764.00	AV	Horizontal	33.54	54.00	-20.46	1.3	200
12205.00	AV	Horizontal	31.23	54.00	-22.77	1.1	180
14646.00	AV	Horizontal	35.13	54.00	-18.87	1.2	260
17087.00	AV	Horizontal	34.36	54.00	-19.64	1.9	155
19528.00	AV	Horizontal	29.04	54.00	-24.96	1.1	150
21969.00	AV	Horizontal	30.09	54.00	-23.91	1.2	190
24410.00	AV	Horizontal	28.27	54.00	-25.73	1.8	210
2441.00	PK	Vertical	105.78		(Fund.)	1.1	0
4882.00	PK	Vertical	62.18	74.00	-11.82	1.2	160
7323.00	PK	Vertical	60.29	74.00	-13.71	1.7	150
9764.00	PK	Vertical	56.15	74.00	-17.85	1.0	190
12205.00	PK	Vertical	59.39	74.00	-14.61	1.7	190
14646.00	PK	Vertical	52.06	74.00	-21.94	1.3	80
17087.00	PK	Vertical	55.31	74.00	-18.69	1.3	30
19528.00	PK	Vertical	50.12	74.00	-23.88	1.3	200
21969.00	PK	Vertical	54.11	74.00	-19.89	1.8	155
24410.00	PK	Vertical	47.17	74.00	-26.83	1.1	180
2441.00	PK	Horizontal	101.98		(Fund.)	1.6	40
4882.00	PK	Horizontal	57.25	74.00	-16.75	1.8	135
7323.00	PK	Horizontal	58.98	74.00	-15.02	1.5	90
9764.00	PK	Horizontal	53.09	74.00	-20.91	1.3	130
12205.00	PK	Horizontal	55.84	74.00	-18.16	1.7	200
14646.00	PK	Horizontal	51.24	74.00	-22.76	1.2	220
17087.00	PK	Horizontal	48.43	74.00	-25.57	1.1	130
19528.00	PK	Horizontal	51.12	74.00	-22.88	1.6	230
21969.00	PK	Horizontal	52.35	74.00	-21.65	1.0	30
24410.00	PK	Horizontal	47.03	74.00	-26.97	1.4	225
High frequency							

The results shown in this test report refer only to the sample(s) tested , This Test report cannot be reproduced, except in full, without prior written permission of the company.

2480.00	AV	Vertical	95.71		(Fund.)	1.0	190
4960.00	AV	Vertical	41.22	54.00	-12.78	1.7	80
7440.00	AV	Vertical	40.18	54.00	-13.82	1.2	150
9920.00	AV	Vertical	38.66	54.00	-15.34	1.2	140
12400.00	AV	Vertical	37.22	54.00	-16.78	1.8	110
14880.00	AV	Vertical	40.76	54.00	-13.24	1.8	180
17360.00	AV	Vertical	34.15	54.00	-19.85	1.1	140
19840.00	AV	Vertical	31.44	54.00	-22.56	1.2	270
22320.00	AV	Vertical	38.21	54.00	-15.79	1.3	120
24800.00	AV	Vertical	30.17	54.00	-23.83	1.3	205
2480.00	AV	Horizontal	91.96		(Fund.)	1.4	170
4960.00	AV	Horizontal	39.51	54.00	-14.49	2.4	220
7440.00	AV	Horizontal	34.88	54.00	-19.12	1.2	130
9920.00	AV	Horizontal	35.45	54.00	-18.55	1.6	260
12400.00	AV	Horizontal	36.72	54.00	-17.28	1.1	165
14880.00	AV	Horizontal	33.27	54.00	-20.73	1.0	200
17360.00	AV	Horizontal	30.43	54.00	-23.57	1.7	200
19840.00	AV	Horizontal	33.06	54.00	-20.94	1.8	120
22320.00	AV	Horizontal	28.32	54.00	-25.68	1.3	130
24800.00	AV	Horizontal	29.17	54.00	-24.83	2.5	180
2480.00	PK	Vertical	105.22		(Fund.)	1.1	180
4960.00	PK	Vertical	60.75	74.00	-13.25	1.3	100
7440.00	PK	Vertical	57.18	74.00	-16.82	2.4	160
9920.00	PK	Vertical	59.64	74.00	-14.36	1.2	170
12400.00	PK	Vertical	54.74	74.00	-19.26	1.4	100
14880.00	PK	Vertical	61.29	74.00	-12.71	1.3	140
17360.00	PK	Vertical	55.32	74.00	-18.68	1.1	120
19840.00	PK	Vertical	56.19	74.00	-17.81	1.0	200
22320.00	PK	Vertical	54.51	74.00	-19.49	1.9	140
24800.00	PK	Vertical	48.13	74.00	-25.87	1.3	195
2480.00	PK	Horizontal	99.37		(Fund.)	1.7	220
4960.00	PK	Horizontal	57.14	74.00	-16.86	1.5	150
7440.00	PK	Horizontal	55.45	74.00	-18.55	1.4	120
9920.00	PK	Horizontal	56.27	74.00	-17.73	1.1	250
12400.00	PK	Horizontal	54.13	74.00	-19.87	1.5	140
14880.00	PK	Horizontal	48.32	74.00	-25.68	1.7	160
17360.00	PK	Horizontal	52.53	74.00	-21.47	1.9	160
19840.00	PK	Horizontal	47.20	74.00	-26.80	1.6	230
22320.00	PK	Horizontal	50.03	74.00	-23.97	2.2	150
24800.00	PK	Horizontal	45.41	74.00	-28.59	1.7	270

The results shown in this test report refer only to the sample(s) tested , This Test report cannot be reproduced, except in full, without prior written permission of the company.

7.7 Photograph – Radiation Spurious Emission Test Setup

Below 30MHz

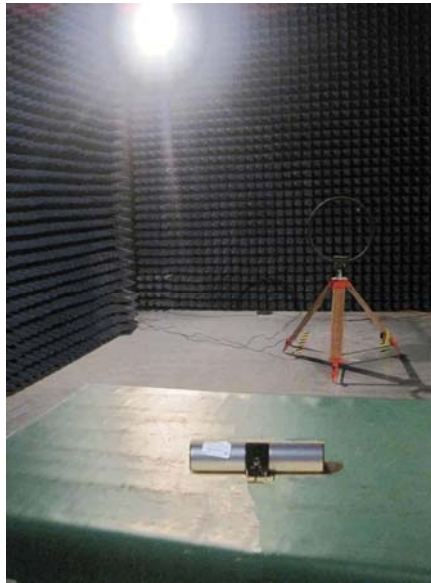

30Mhz~1GHz

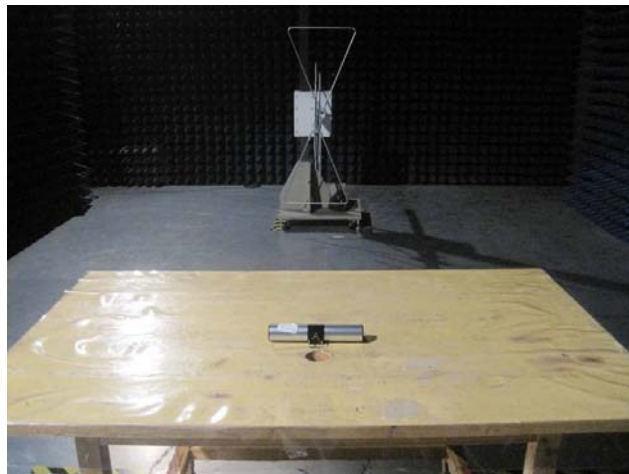

Above 1GHz

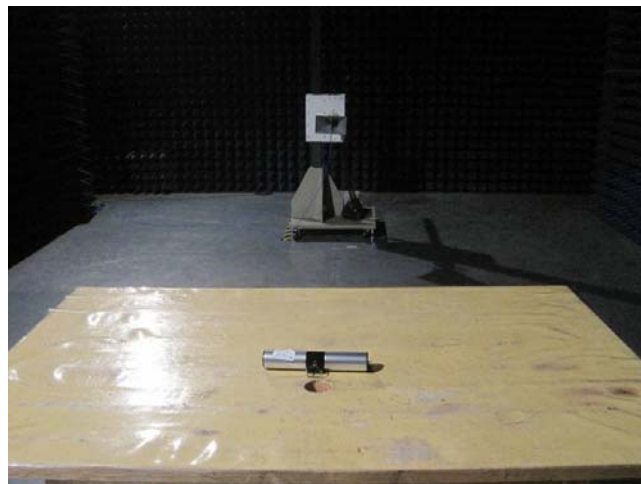

The results shown in this test report refer only to the sample(s) tested , This Test report cannot be reproduced, except in full, without prior written permission of the company.

8 Band Edge Measurements

Test Requirement:	Section 15.247(d) In addition, radiated emissions which fall in the restricted bands. as defined in Section 15.205(a), must also comply with the radiated emission limits specified in Section 15.209(a) (see Section 15.205(c)).
Test Method:	Complies with DA 00-705
Measurement Distance:	3m
Limit:	40.0 dBuV/m between 30MHz & 88MHz; 43.5 dBuV/m between 88MHz & 216MHz; 46.0 dBuV/m between 216MHz & 960MHz; 54.0 dBuV/m above 960MHz. 74.0 dBuV/m for peak above 1GHz 54.0 dBuV/m for AVG above 1GHz
Detector:	For Peak value: RBW = 1 MHz for $f \geq 1$ GHz VBW \geq RBW; Sweep = auto Detector function = peak Trace = max hold For AVG value: RBW = 1 MHz for $f \geq 1$ GHz VBW = 10Hz; Sweep = auto Detector function = AVG Trace = max hold

Test Result:
Low Channel – Peak

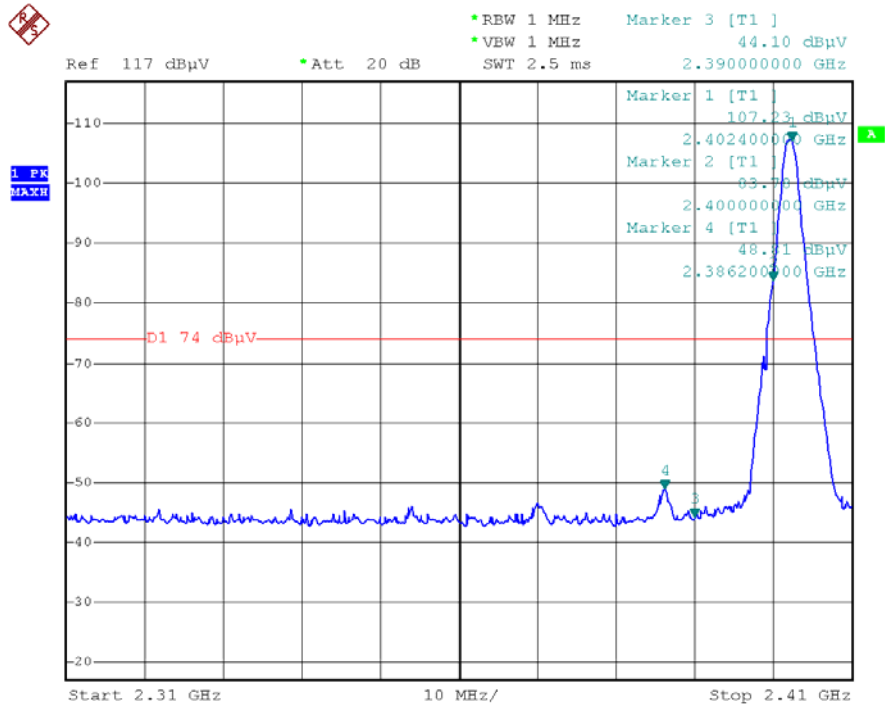

The results shown in this test report refer only to the sample(s) tested , This Test report cannot be reproduced, except in full, without prior written permission of the company.

Low Channel – AV

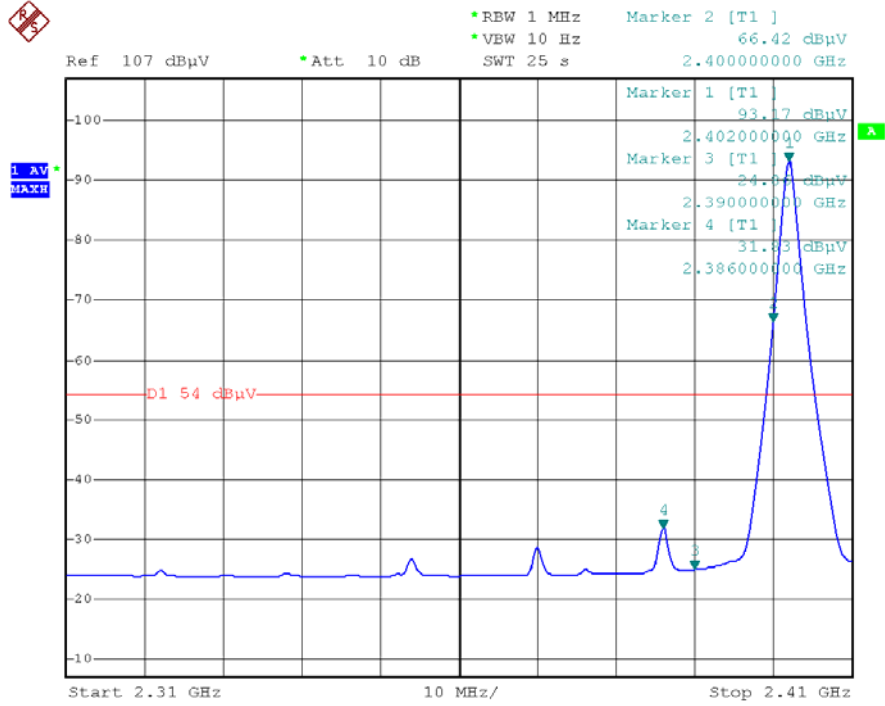

The results shown in this test report refer only to the sample(s) tested , This Test report cannot be reproduced, except in full, without prior written permission of the company.

High Channel – Peak

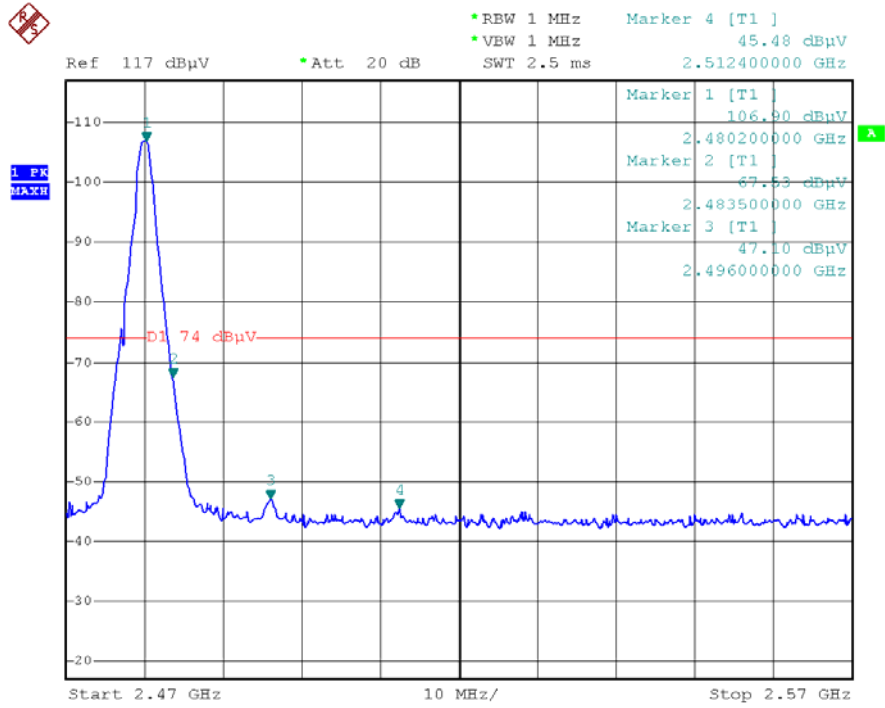

The results shown in this test report refer only to the sample(s) tested , This Test report cannot be reproduced, except in full, without prior written permission of the company.

High Channel – AV

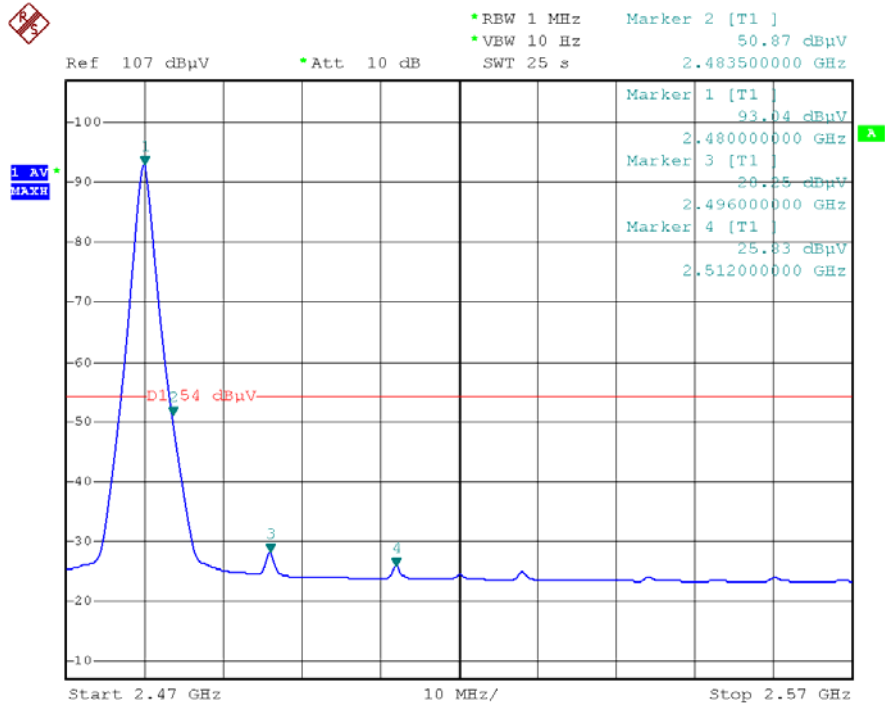

The results shown in this test report refer only to the sample(s) tested , This Test report cannot be reproduced, except in full, without prior written permission of the company.

9 20 dB Bandwidth Measurement

Test Requirement: FCC CFR47 Part 15 Section 15.247
 Test Method: Complies with DA 00-705
 Test Mode: Test in fixing operating frequency at low, Middle, high channel.

9.1 Test Procedure:

1. Remove the antenna from the EUT and then connect a low RF cable from the antenna port to the spectrum;
2. Set the spectrum analyzer: Span = 4MHz, RBW = 100kHz, VBW = 100kHz

9.2 Test Result:

Test Channel	Bandwidth
Low	1.112MHz
Middle	1.112MHz
High	1.112MHz

Test result plot as follows:

Low Channel

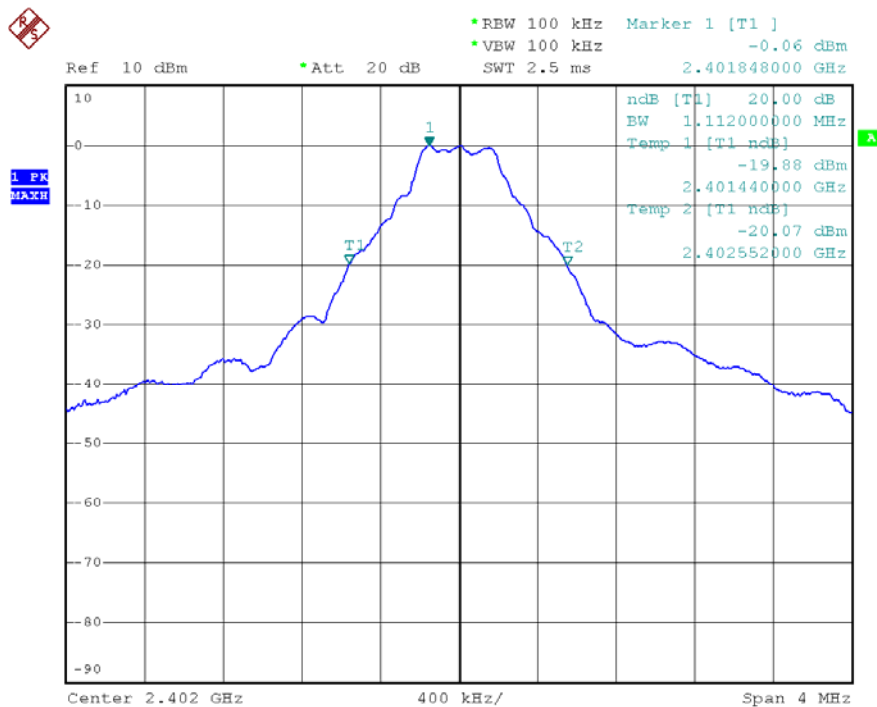

The results shown in this test report refer only to the sample(s) tested , This Test report cannot be reproduced, except in full, without prior written permission of the company.

Middle Channel

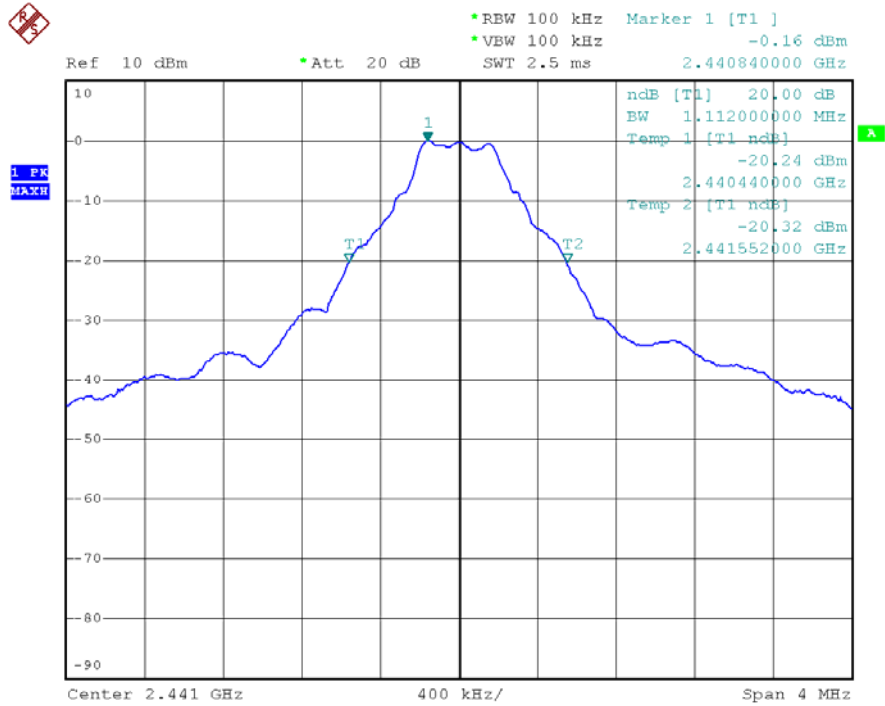

High Channel

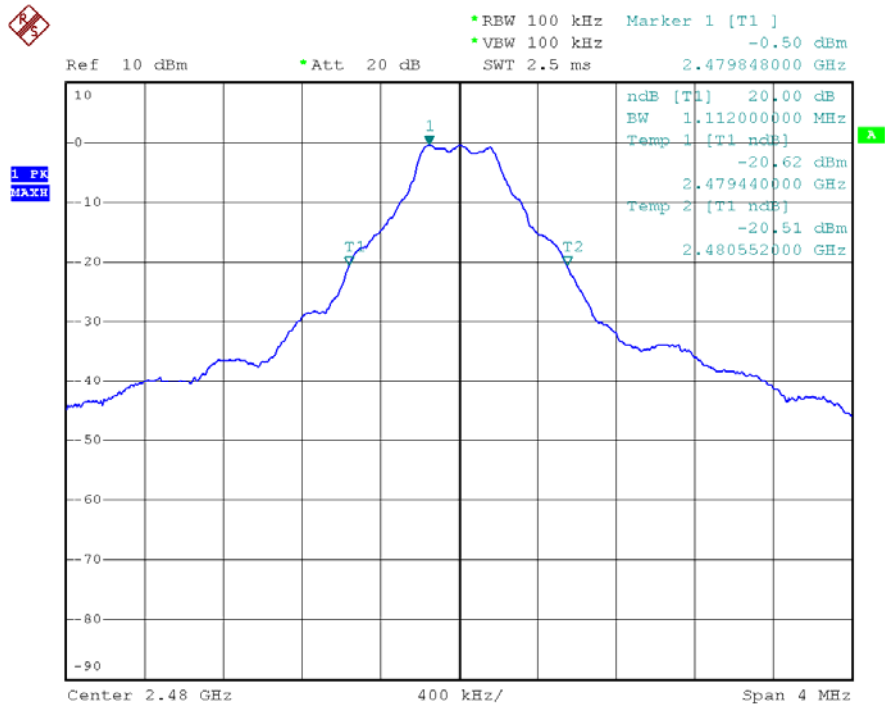

The results shown in this test report refer only to the sample(s) tested , This Test report cannot be reproduced, except in full, without prior written permission of the company.

10 Maximum Peak Output Power

Test Requirement:	FCC CFR47 Part 15 Section 15.247
Test Method:	ANSI C63.4:2003
Test Limit:	Regulation 15.247 (b)(1)For frequency hopping systems operating in the 2400-2483.5 MHz band employing at least 75 non-overlapping hopping channels, and all frequency hopping systems in the 5725-5850 MHz band: 1 watt. For all other frequency hopping systems in the 2400-2483.5 MHz band: 0.125 watts. Refer to the result “Number of Hopping Frequency” of this document. The 1 watts (30 dBm) limit applies.
Test mode:	Test in fixing frequency transmitting mode.

10.1 Test Procedure:

1. Remove the antenna from the EUT and then connect a low RF cable from the antenna port to the spectrum.
2. Set the spectrum analyzer: RBW = 3 MHz. VBW = 10 MHz. Sweep = auto; Detector Function = Peak.
3. Keep the EUT in transmitting at lowest, medium and highest channel individually. Record the max value.

10.2 Test Result:

Test Channel	Output Power (dBm)	Limit (dBm)
Low	0.26	30
Middle	0.22	30
High	-0.06	30

11 Hopping Channel Separation

Test Requirement:	FCC CFR47 Part 15 Section 15.247
Test Method:	Complies with DA 00-705
Test Limit:	Regulation 15.247(a)(1) Frequency hopping systems shall have hopping channel carrier frequencies separated by a minimum of 25 kHz or the 20 dB bandwidth of the hopping channel, whichever is greater. Alternatively, frequency hopping systems operating in the 2400-2483.5 MHz band may have hopping channel carrier frequencies that are separated by 25 kHz or two-thirds of the 20 dB bandwidth of the hopping channel, whichever is greater, provided the systems operate with an output power no greater than 125 mW.
Test Mode:	Test in hopping transmitting operating mode.

11.1 Test Procedure:

1. Remove the antenna from the EUT and then connect a low RF cable from the antenna port to the spectrum.
2. Set the spectrum analyzer: RBW = 30kHz. VBW = 100kHz , Span = 2MHz. Sweep = auto; Detector Function = Peak. Trace = Max hold.
3. Allow the trace to stabilize. Use the marker-delta function to determine the separation between the peaks of the adjacent channels. The limit is specified in one of the subparagraphs of this Section Submit this plot.

11.2 Test Result:

Test Channel	Separation (MHz)	Result
Low	1.000	PASS
Middle	1.000	PASS
High	1.004	PASS

Test result plot as follows:

Low Channel:

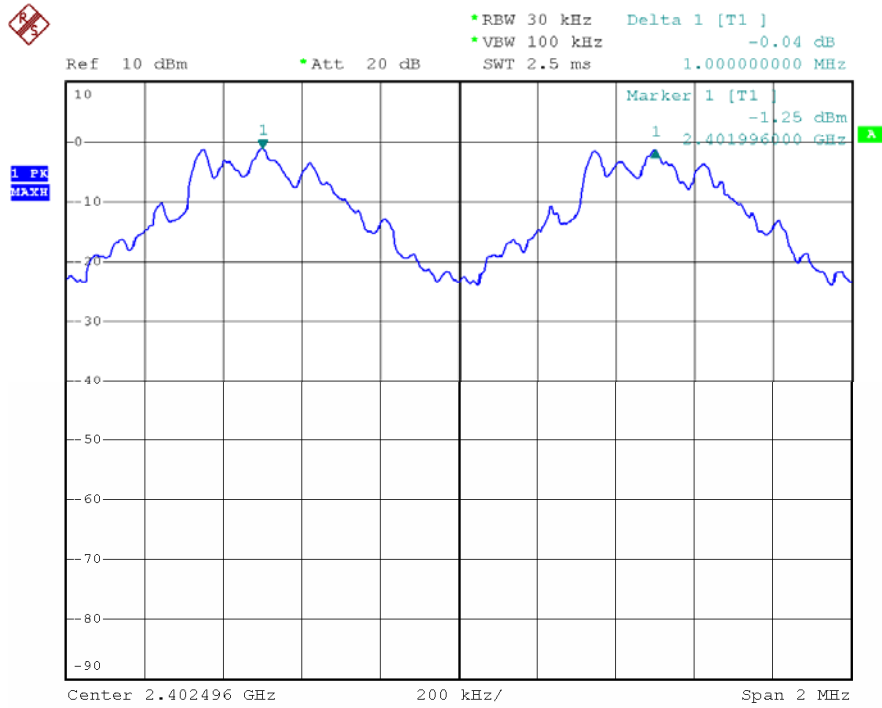

Middle Channel

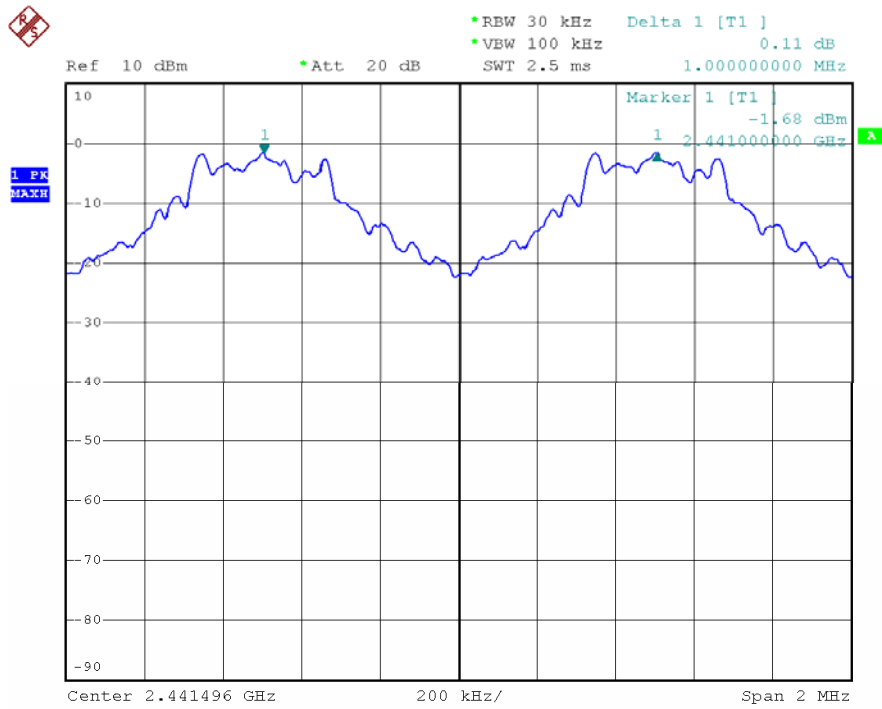

The results shown in this test report refer only to the sample(s) tested , This Test report cannot be reproduced, except in full, without prior written permission of the company.

High Channel

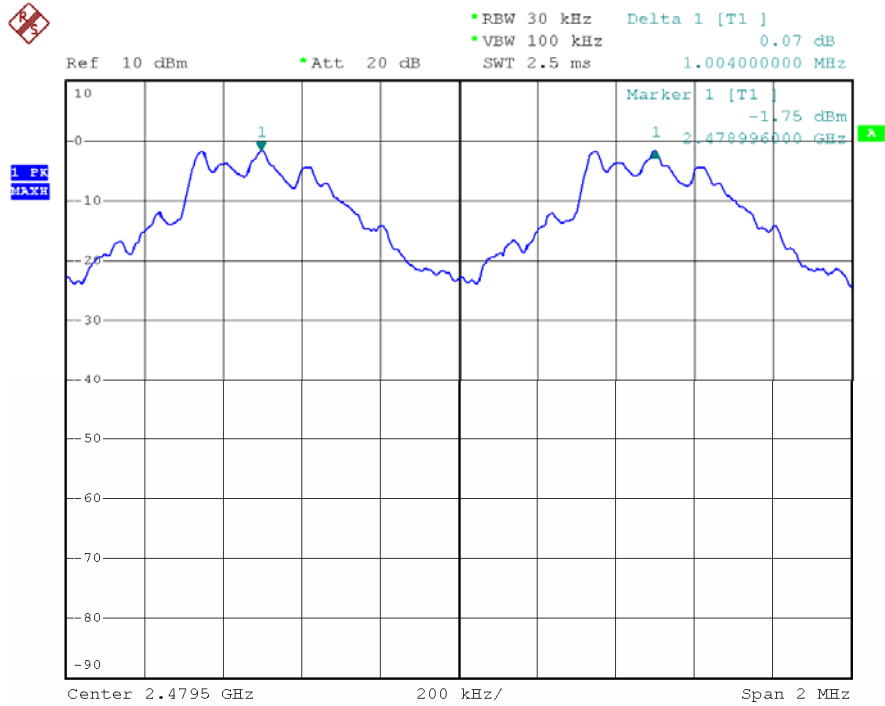

The results shown in this test report refer only to the sample(s) tested , This Test report cannot be reproduced, except in full, without prior written permission of the company.

12 Number of Hopping Frequency

Test Requirement:	FCC CFR47 Part 15 Section 15.247
Test Method:	Complies with DA 00-705
Test Limit:	Regulation 15.247 (a)(1)(iii) Frequency hopping systems in the 2400-2483.5 MHz band shall use at least 15 channels.
Test Mode:	Test in hopping transmitting operating mode.

12.1 Test Procedure:

1. Remove the antenna from the EUT and then connect a low RF cable from the antenna port to the spectrum.
2. Set the spectrum analyzer: RBW = 100 kHz. VBW = 100 kHz. Sweep = auto; Detector Function = Peak. Trace = Max hold.
3. Allow the trace to stabilize. It may prove necessary to break the span up to sections. in order to clearly show all of the hopping frequencies. The limit is specified in one of the subparagraphs of this Section.
4. Set the spectrum analyzer: Center Frequency = 2441MHz, Span = 86MHz. Submit the test result graph.

12.2 Test Result:

Total Channels are 79 Channels

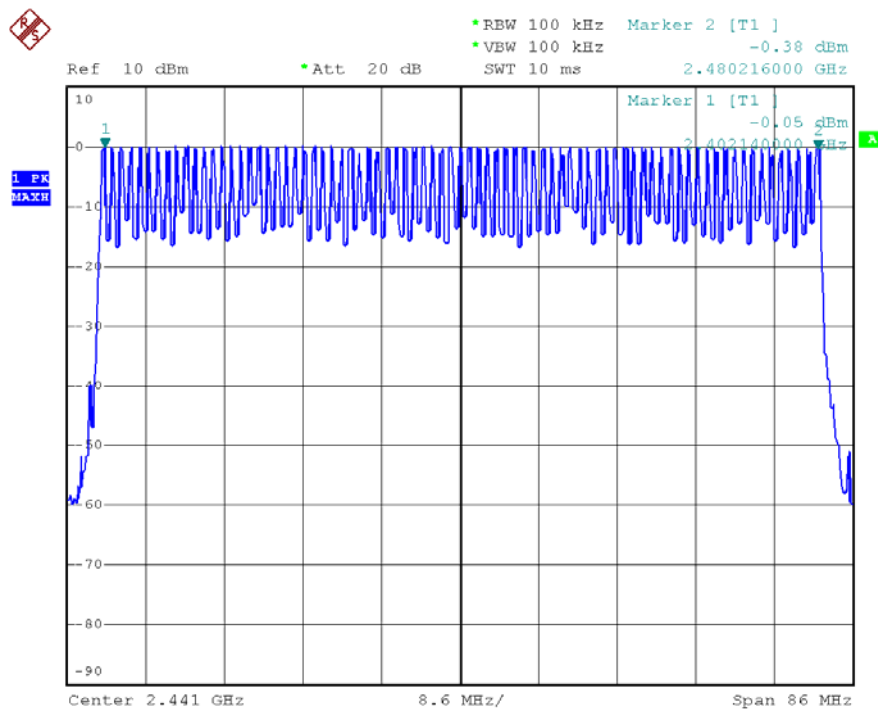

The results shown in this test report refer only to the sample(s) tested , This Test report cannot be reproduced, except in full, without prior written permission of the company.

13 Dwell Time

Test Requirement:	FCC CFR47 Part 15 Section 15.247
Test Method:	Complies with DA 00-705
Test Limit:	Regulation 15.247(a)(1)(iii) Frequency hopping systems in the 2400-2483.5 MHz band shall use at least 15 channels. The average time of occupancy on any channel shall not be greater than 0.4 seconds within a period of 0.4 seconds multiplied by the number of hopping channels employed.
Test Mode:	Test in hopping transmitting operating mode.

13.1 Test Procedure:

- 1.Remove the antenna from the EUT and then connect a low RF cable from the antenna port to the spectrum.
- 2.Set spectrum analyzer span = 0. centered on a hopping channel;
- 3.Set RBW = 1MHz and VBW = 1MHz.Sweep = as necessary to capture the entire dwell time per hopping channel.
- 4.Use the marker-delta function to determine the dwell time. If this value varies with different modes of operation (e.g.. data rate. modulation format. etc.). repeat this test for each variation. The limit is specified in one of the subparagraphs of this Section. Submit this plot(s).

13.2 Test Result:

Dwell time = Pulse wide x (Hopping rate / Number of channels) x Period

The test period: $T = 0.4(s) * 79 = 31.6 (s)$

DH5 Packet permit maximum $1600 / 79 / 6$ hops per second in each channel (5 time slots RX, 1 time slot TX).

DH3 Packet permit maximum $1600 / 79 / 4$ hops per second in each channel (3 time slots RX, 1 time slot TX).

DH1 Packet permit maximum $1600 / 79 / 2$ hops per second in each channel (1 time slot RX, 1 time slot TX). So,the Dwell Time can be calculated as follows:

Data Packet	Dwell Time(s)
DH5	$1600/79/6*31.6*(MkrDelta)/1000$
DH3	$1600/79/4*31.6*(MkrDelta)/1000$
DH1	$1600/79/2*31.6*(MkrDelta)/1000$

Note : Mkr Delta is once pulse time .

Low Channel: 2402MHz

Dwell time of each occupation in this channel as follows:

Data Packet	Frequency	Mkr Delta(ms)	Dwell Time(s)	Limits(s)	Result
DH5	2402 MHz	2.942	0.314	0.400	Pass
DH3	2402 MHz	1.686	0.270	0.400	Pass
DH1	2402 MHz	0.414	0.132	0.400	Pass

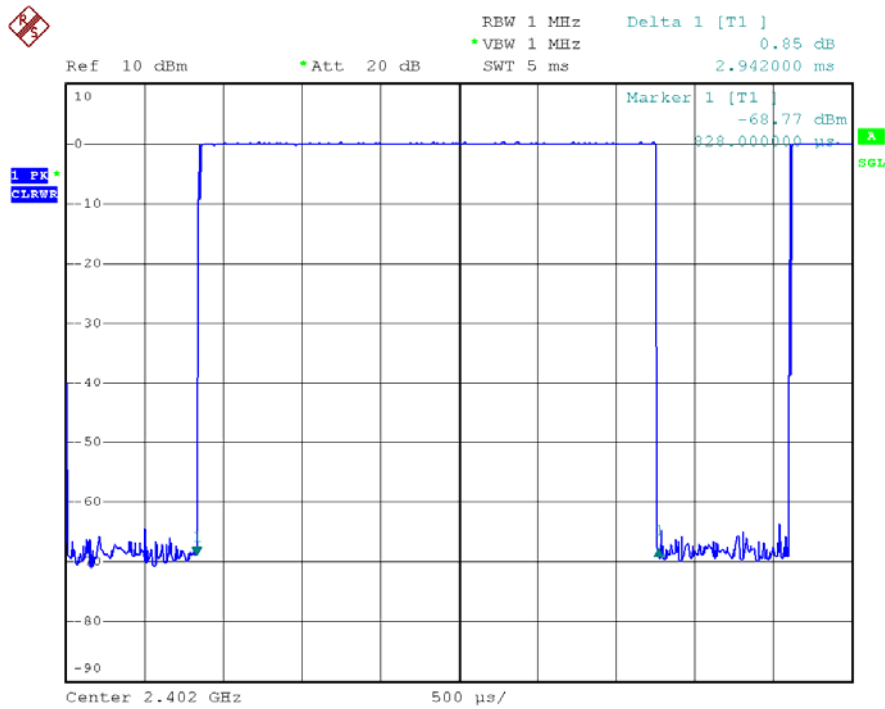

(DH5)

The results shown in this test report refer only to the sample(s) tested , This Test report cannot be reproduced, except in full, without prior written permission of the company.

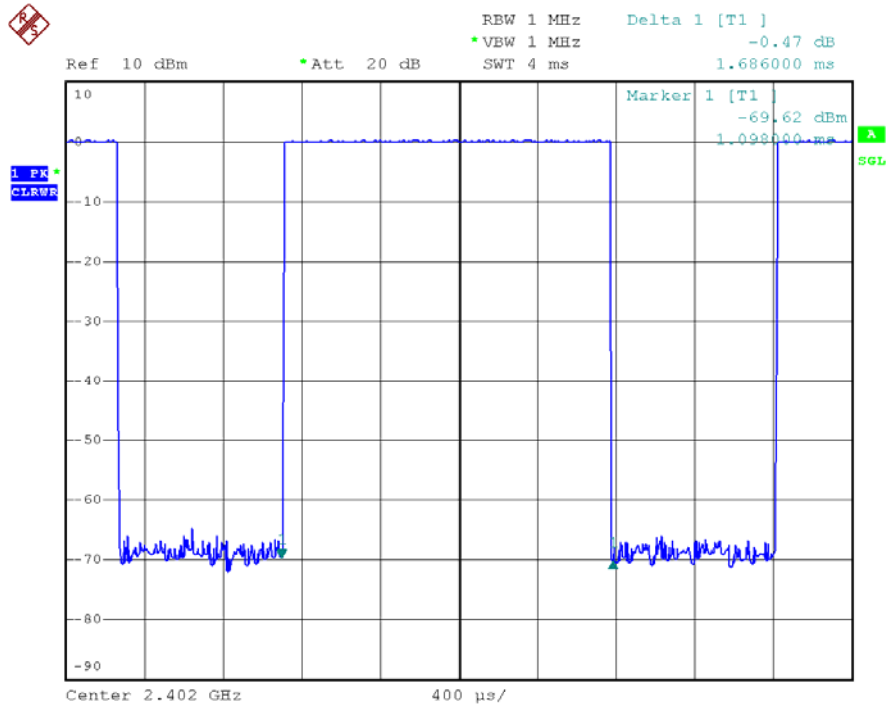

(DH3)

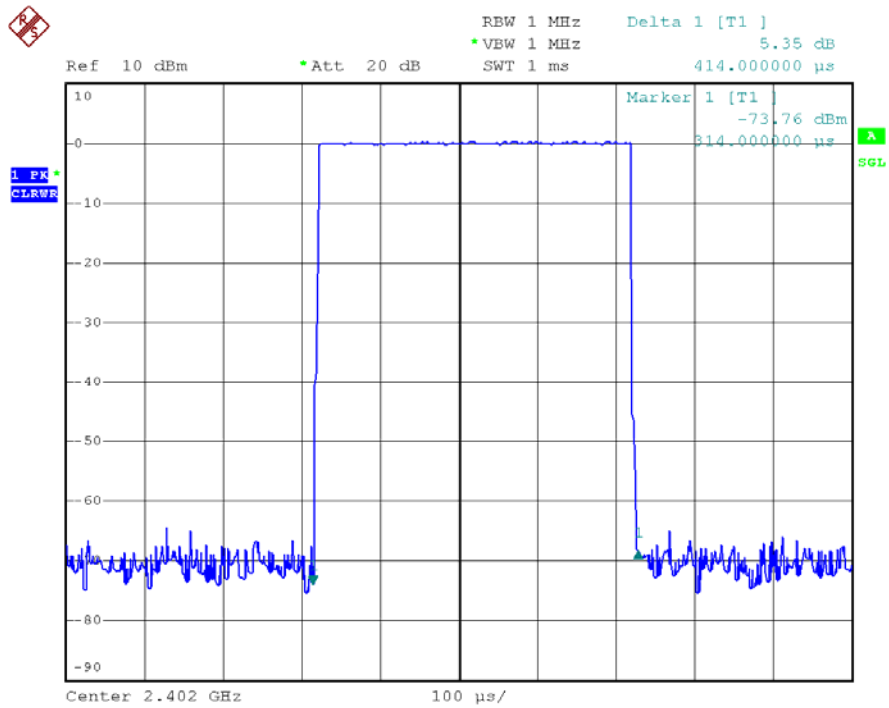

(DH1)

The results shown in this test report refer only to the sample(s) tested , This Test report cannot be reproduced, except in full, without prior written permission of the company.

Middle Channel: 2441MHz

Dwell time of each occupation in this channel as follows:

Data Packet	Frequency	Mkr Delta(ms)	Dwell Time(s)	Limits(s)	Result
DH5	2441 MHz	2.936	0.313	0.400	Pass
DH3	2441 MHz	1.690	0.270	0.400	Pass
DH1	2441 MHz	0.422	0.135	0.400	Pass

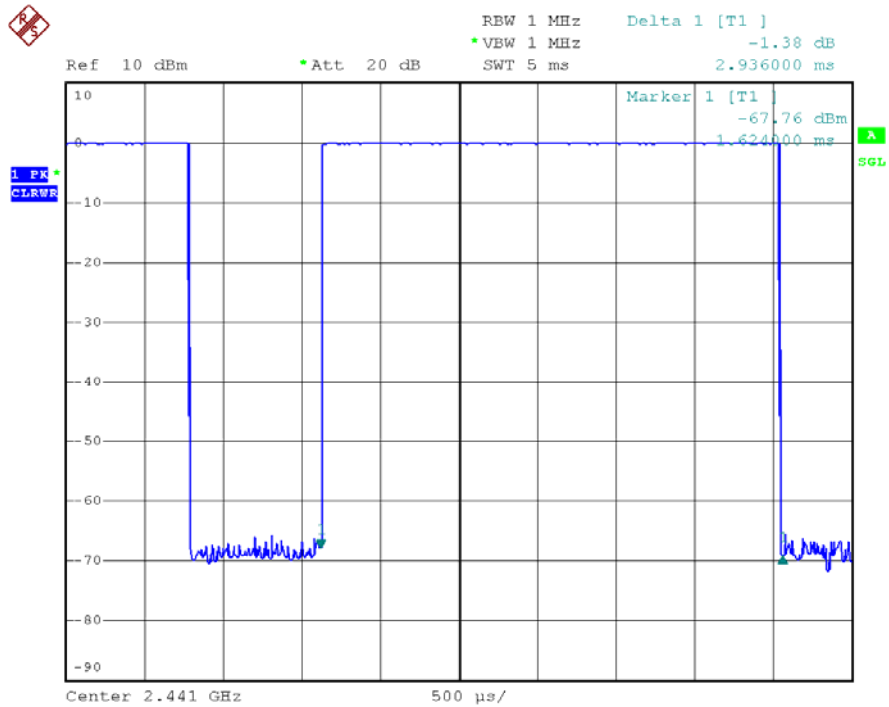

(DH5)

The results shown in this test report refer only to the sample(s) tested , This Test report cannot be reproduced, except in full, without prior written permission of the company.

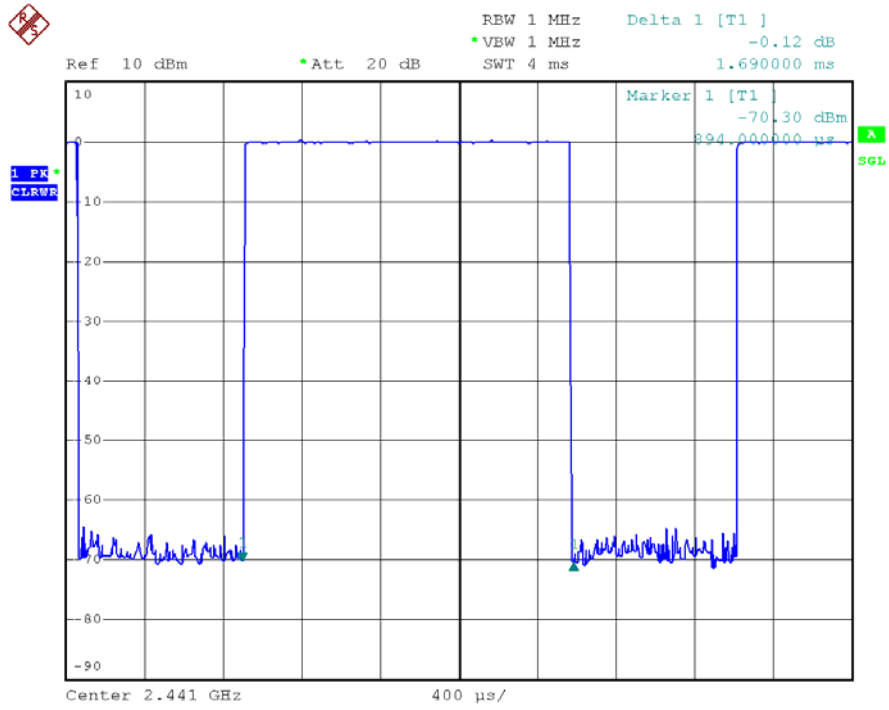

(DH3)

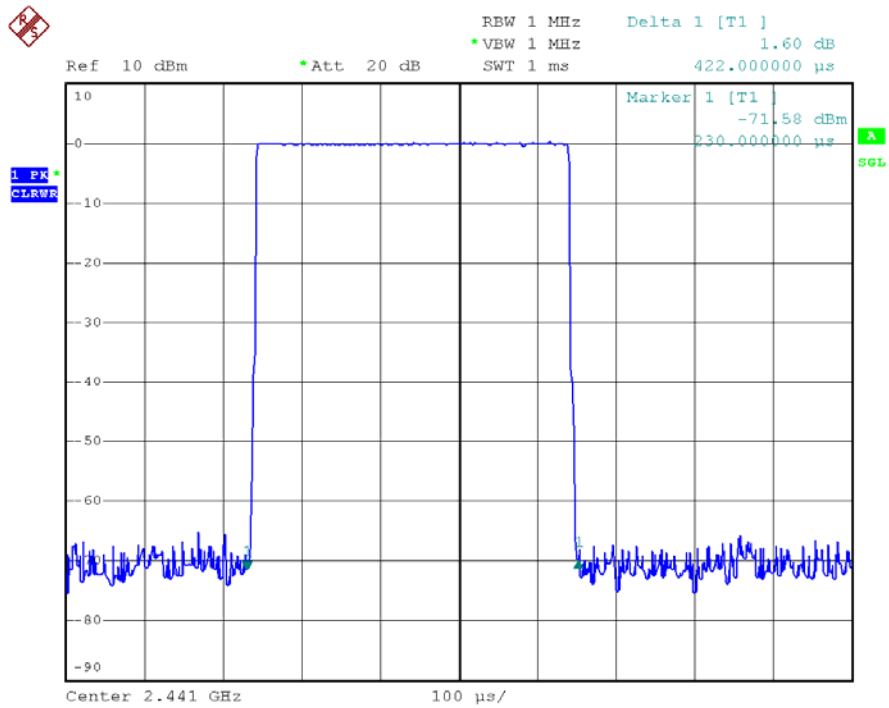

(DH1)

The results shown in this test report refer only to the sample(s) tested , This Test report cannot be reproduced, except in full, without prior written permission of the company.

High Channel: 2480MHz

Dwell time of each occupation in this channel as follows:

Data Packet	Frequency	Mkr Delta(ms)	Dwell Time(s)	Limits(s)	Result
DH5	2480 MHz	2.954	0.315	DH5	Pass
DH3	2480 MHz	1.716	0.275	DH3	Pass
DH1	2480 MHz	0.418	0.134	DH1	Pass

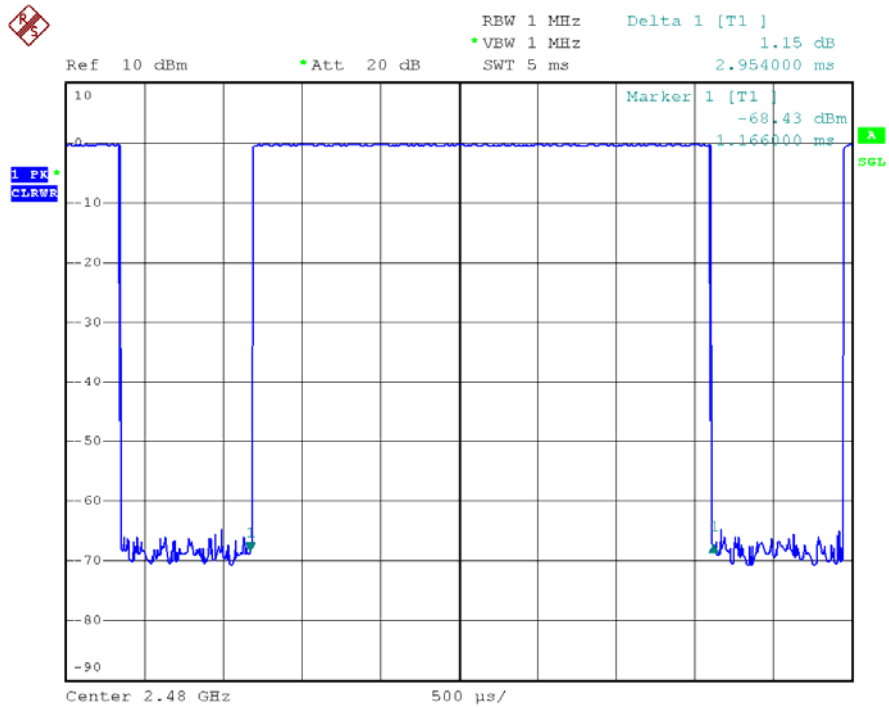

(DH5)

The results shown in this test report refer only to the sample(s) tested , This Test report cannot be reproduced, except in full, without prior written permission of the company.

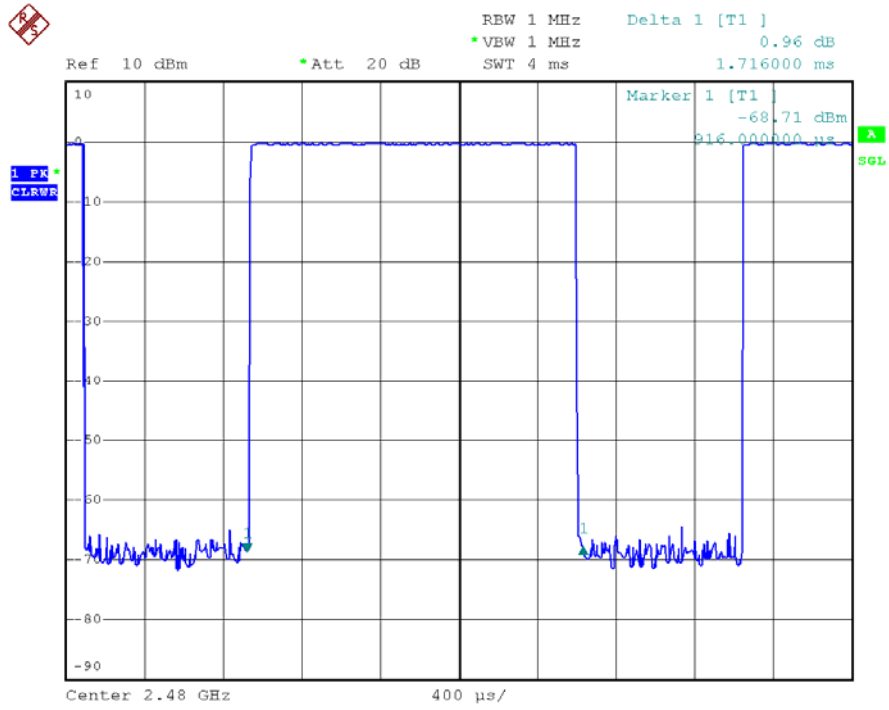

(DH3)

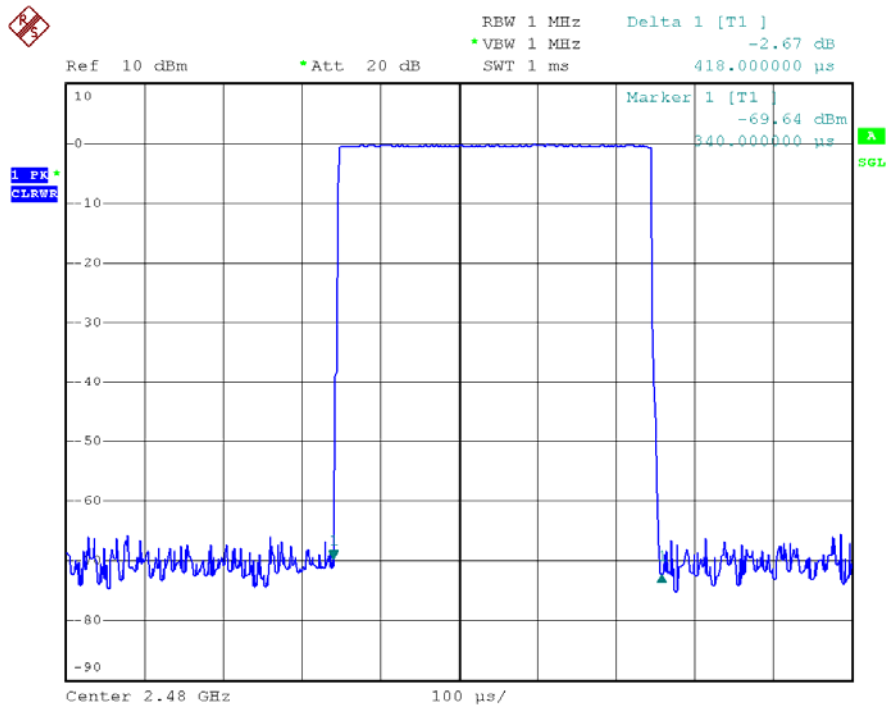

(DH1)

The results shown in this test report refer only to the sample(s) tested , This Test report cannot be reproduced, except in full, without prior written permission of the company.

14 Antenna Requirement

According to the FCC Part 15 Paragraph 15.203, an intentional radiator shall be designed to ensure that no antenna other than that furnished by the responsible party shall be used with the device. The use of a permanently attached antenna or of an antenna that uses a unique coupling to the intentional radiator shall be considered sufficient to comply with the provisions of this section. This product has a permanent PCB printed antenna, fulfill the requirement of this section.

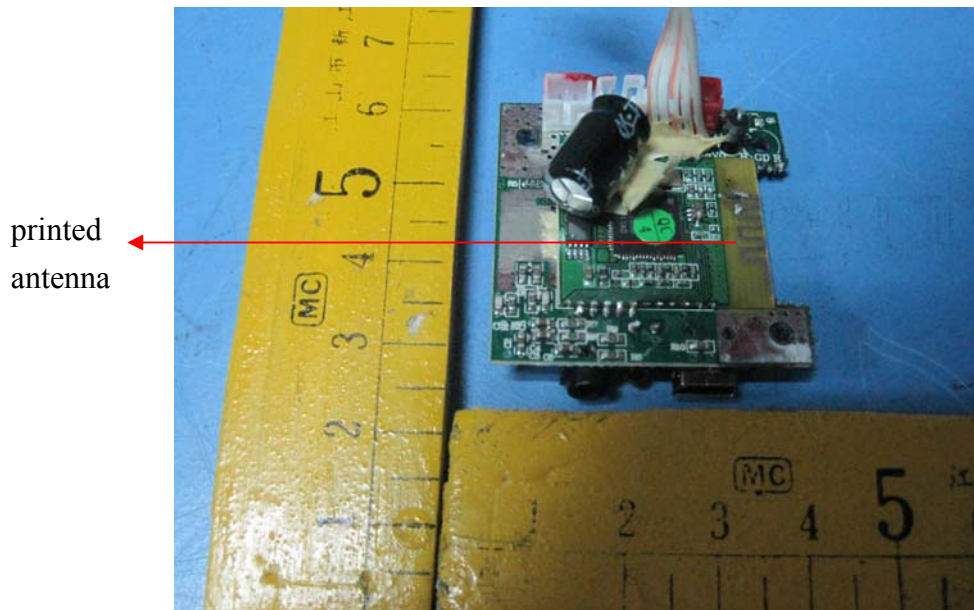

15 RF Exposure

15.1 Requirments:

According to §1.1307(b)(1), systems operating under the provisions of this section shall be operated in a manner that ensure that the public is not exposed to radio frequency energy level in excess of the Commission's guideline.

This is a portable device.

15.2 Measurement Result:

Antenna Gain (dBi)	Antenna Gain (numeric)	Conducted Power (dBm)	Conducted Power (mW)	Radiated Power (e.i.r.p) (mW)
0	1	0.26	1.062	1.062
0	1	0.22	1.052	1.052
0	1	-0.06	0.986	0.986

The EUT works on the 2.4G ISM band, and the max output power (conducted) of which is 1.062 mW lower than low threshold 60/f (GHz) mW (24.48mW), $d < 2.5\text{cm}$ in general population category.

The SAR evaluation is not required.

16 Photographs - Constructional Details

16.1 Product View



16.2 EUT – Appearance View

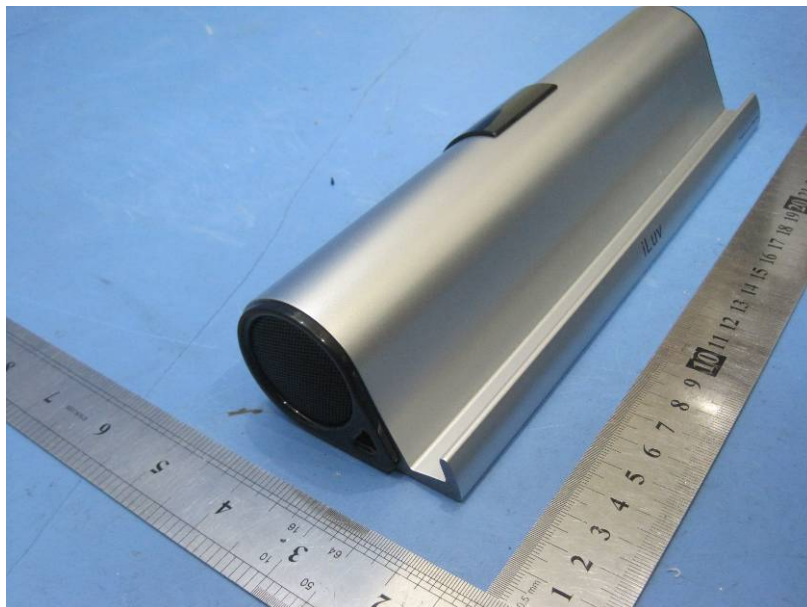

The results shown in this test report refer only to the sample(s) tested , This Test report cannot be reproduced, except in full, without prior written permission of the company.

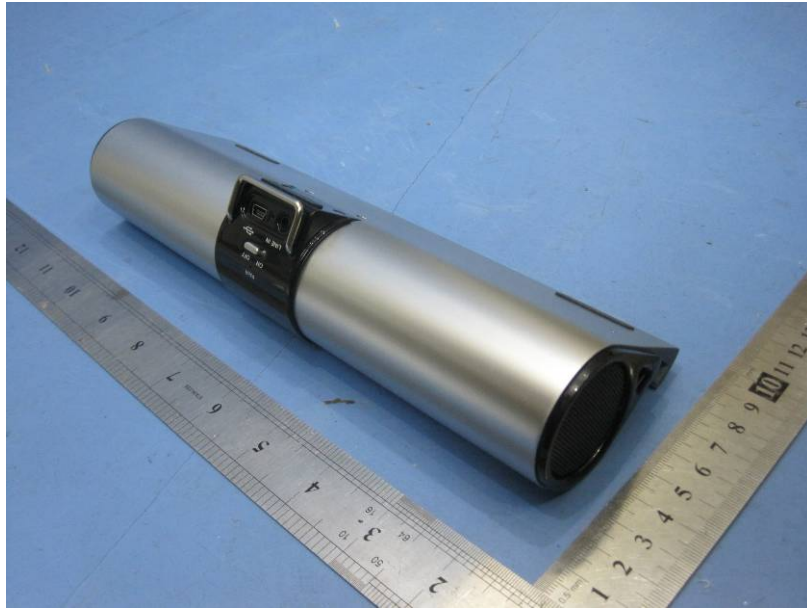

16.3 EUT – Open View

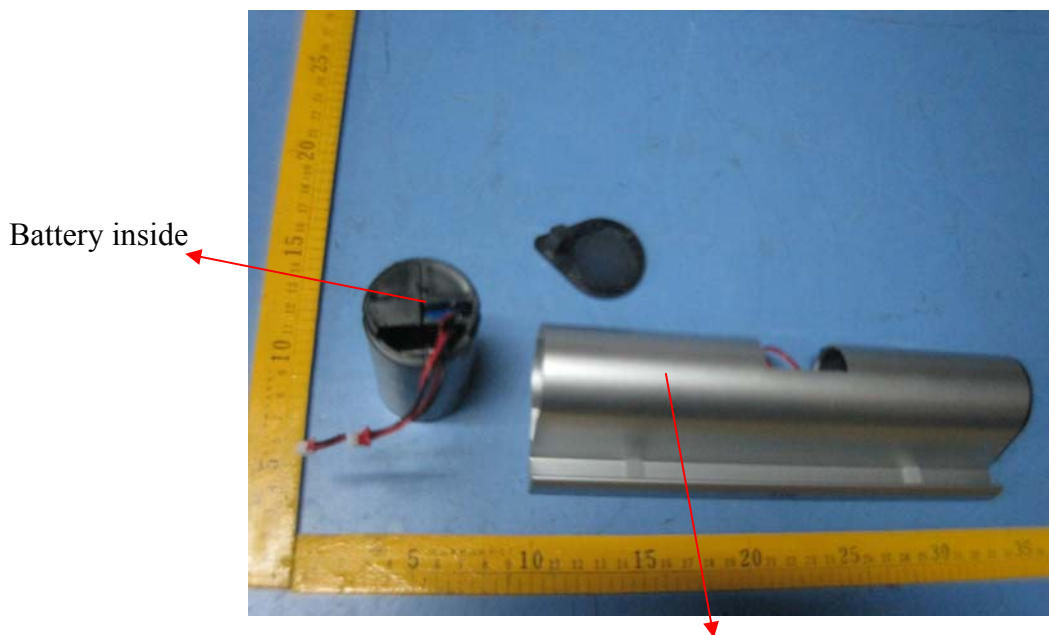

Remark: This battery and speaker box removed from left side of the device.

16.4 EUT – PCB1 View

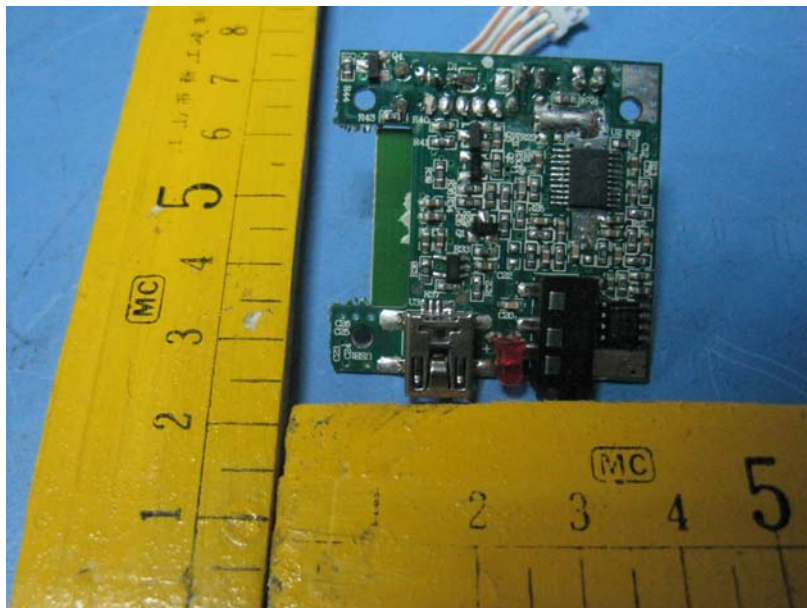
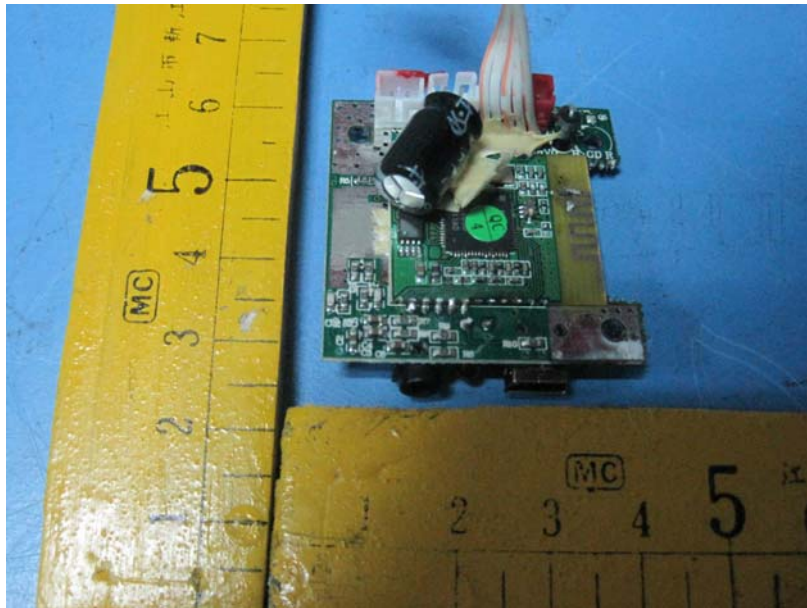

16.5 Module – PCB View

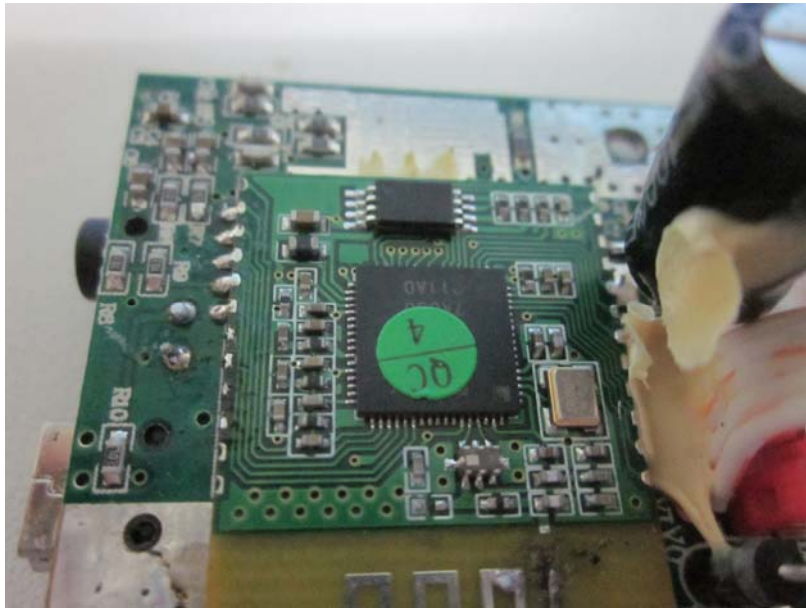

16.6 EUT – PCB2 View

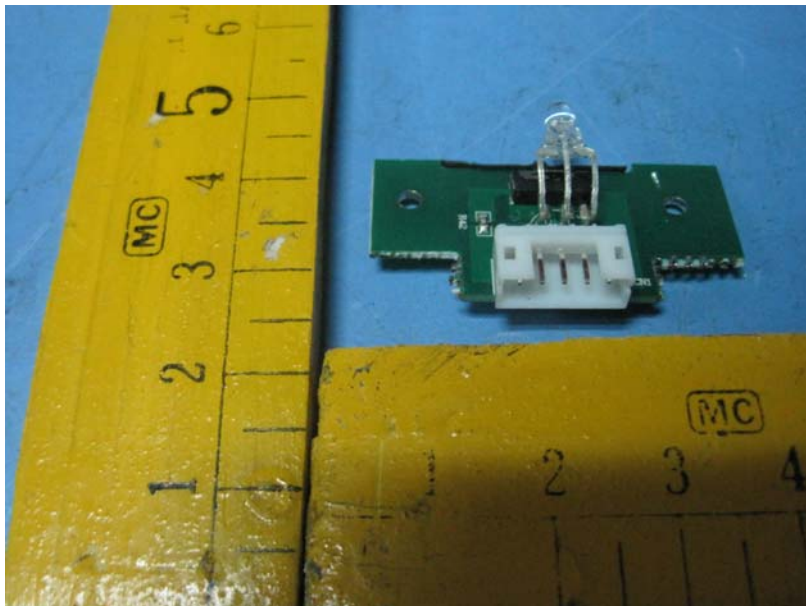

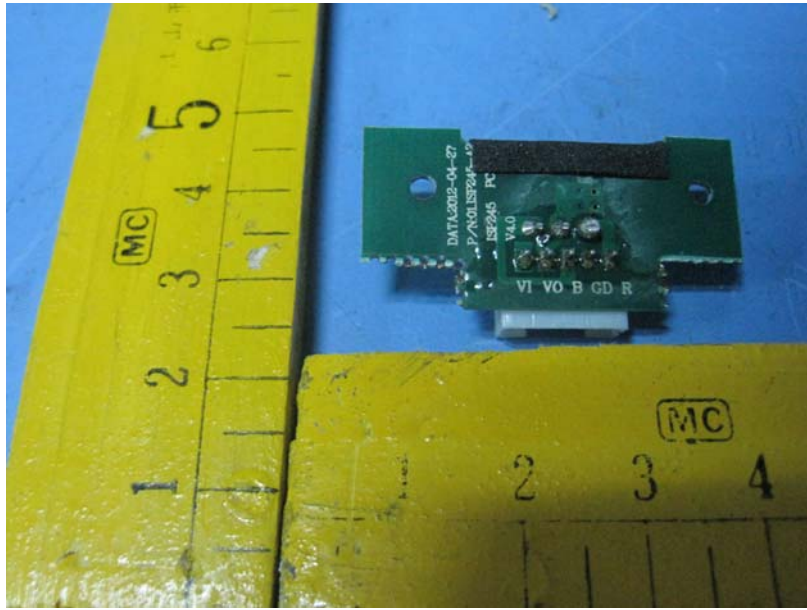

17 FCC Label

This device complies with Part 15 of the FCC Rules. Operation is subject to the following two conditions:(1)this device may not cause harmful interference,and (2) this device must accept any interference received, including interference that may cause undesired operation.

The Label must not be a stick-on paper. The Label on these products must be permanently affixed to the product and readily visible at the time of purchase and must last the expected lifetime of the equipment not be readily detachable.

Proposed Label Location on EUT
EUT Back View/ proposed FCC Label Location



The results shown in this test report refer only to the sample(s) tested , This Test report cannot be reproduced, except in full, without prior written permission of the company.