

MODEL: OHM91001

CUSTOMER: ACTION STANDARD

DATE: 16/07/09

DESCRIPTION: LABEL LOCATION ON UNIT

REVISION: 0

PAGE: 5 OF: 10

### FRONT PANEL

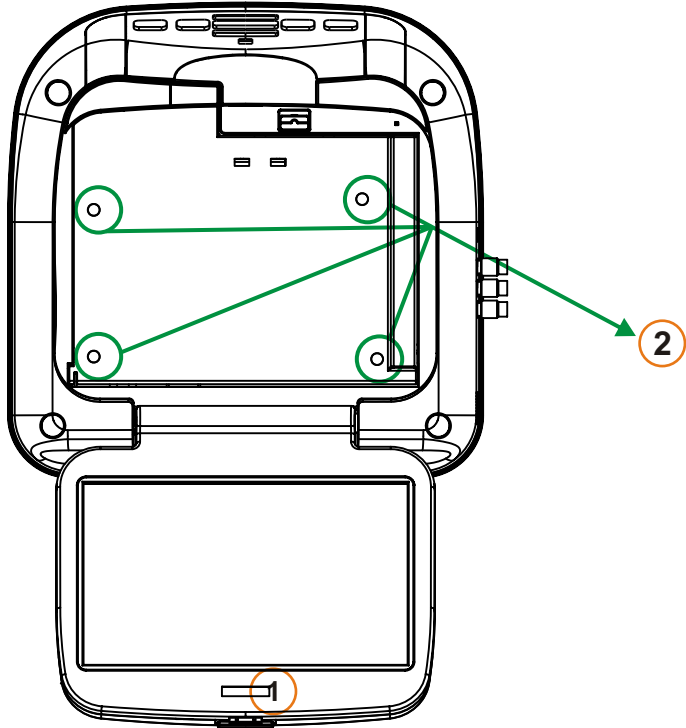

1. LOGO PLATE (32 x 6.5MM)  
(P/N: 50-KC-00010G)



2. DOT LABEL (8MM) (P/N: 51-1A-10160G)



### BACK PANEL

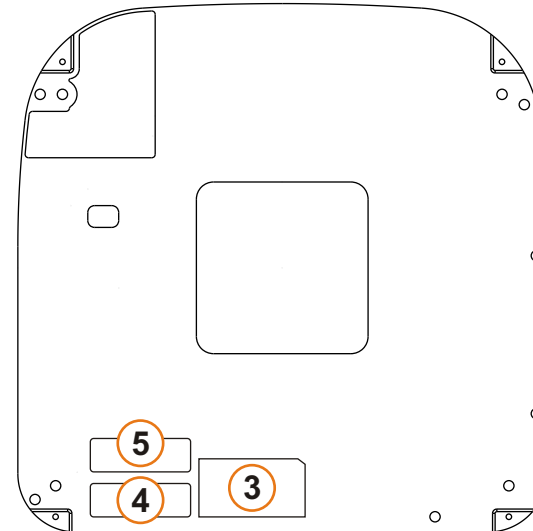

3. MODEL LABEL (53 x 29MM)  
(P/N: 50-N7-xxxx0G)



4. FCC ID LABEL (44x7MM)



5. SERIAL NUMBER (OHM91001)  
(P/N: 90-N7-xxxx0G)

