



# FCC PART 15.247

## TEST REPORT

For

### Action Electronics Co., Ltd.

No. 198, Chung Yuan Road Chung, Chung Li, Taiwan

**FCC ID: AT19R3MID30801**

<b>Report Type:</b> Original Report	<b>Product Type:</b> 8" Tablet PC
<b>Test Engineer:</b> Leon Chen	<i>Leon Chen</i>
<b>Report Number:</b> R2DG130821007-00A	
<b>Report Date:</b> 2013-11-11	
<b>Reviewed By:</b> Ivan Cao RF Leader	<i>Ivan Cao</i>
<b>Test Laboratory:</b> Bay Area Compliance Laboratories Corp. (Dongguan) No.69 Pulongcun, Puxinhu Industrial Zone, Tangxia, Dongguan, Guangdong, China Tel: +86-769-86858888 Fax: +86-769-86858891 <a href="http://www.baclcorp.com.cn">www.baclcorp.com.cn</a>	

**Note:** This test report is prepared for the customer shown above and for the device described herein. It may not be duplicated or used in part without prior written consent from Bay Area Compliance Laboratories Corp. This report **must not** be used by the customer to claim product certification, approval, or endorsement by NVLAP\*, or any agency of the Federal Government.  
\* This report may contain data that are not covered by the NVLAP accreditation and shall be marked with an asterisk "★" (Rev.2).  
This report is valid only with a valid digital signature. The digital signature may be available only under the Adobe software above version 7.0.

**TABLE OF CONTENTS**

**GENERAL INFORMATION.....4**

    PRODUCT DESCRIPTION FOR EQUIPMENT UNDER TEST (EUT).....4

    OBJECTIVE.....4

    RELATED SUBMITTAL(S)/GRANT(S).....4

    TEST METHODOLOGY.....4

    TEST FACILITY.....5

**SYSTEM TEST CONFIGURATION.....6**

    DESCRIPTION OF TEST CONFIGURATION.....6

    EUT EXERCISE SOFTWARE.....6

    EQUIPMENT MODIFICATIONS.....6

    SUPPORT EQUIPMENT LIST AND DETAILS.....7

    EXTERNAL I/O CABLE.....7

    BLOCK DIAGRAM OF TEST SETUP.....7

**SUMMARY OF TEST RESULTS.....8**

**FCC §15.247 (i) & §1.1310 & §2.1093- RF EXPOSURE.....9**

    APPLICABLE STANDARD.....9

**FCC §15.203 - ANTENNA REQUIREMENT.....10**

    APPLICABLE STANDARD.....10

    ANTENNA CONNECTOR CONSTRUCTION.....10

**FCC §15.207 (a) – AC LINE CONDUCTED EMISSIONS.....11**

    APPLICABLE STANDARD.....11

    MEASUREMENT UNCERTAINTY.....11

    EUT SETUP.....11

    EMI TEST RECEIVER SETUP.....12

    TEST PROCEDURE.....12

    CORRECTED AMPLITUDE & MARGIN CALCULATION.....12

    TEST EQUIPMENT LIST AND DETAILS.....13

    TEST RESULTS SUMMARY.....13

    TEST DATA.....13

**FCC §15.209, §15.205 & §15.247(d) - SPURIOUS EMISSIONS.....16**

    APPLICABLE STANDARD.....16

    MEASUREMENT UNCERTAINTY.....16

    EUT SETUP.....16

    EMI TEST RECEIVER & SPECTRUM ANALYZER SETUP.....17

    TEST PROCEDURE.....17

    CORRECTED AMPLITUDE & MARGIN CALCULATION.....18

    TEST EQUIPMENT LIST AND DETAILS.....18

    TEST RESULTS SUMMARY.....18

    TEST DATA.....19

**FCC §15.247(a) (2) – 6 dB EMISSION BANDWIDTH.....28**

    APPLICABLE STANDARD.....28

    TEST PROCEDURE.....28

    TEST EQUIPMENT LIST AND DETAILS.....28

    TEST DATA.....28

**FCC §15.247(b) (3) - MAXIMUM CONDUCTED OUTPUT POWER.....34**

APPLICABLE STANDARD .....34  
TEST PROCEDURE .....34  
TEST EQUIPMENT LIST AND DETAILS.....34  
TEST DATA .....35

**FCC §15.247(d) – 100 kHz BANDWIDTH OF FREQUENCY BAND EDGE.....45**  
APPLICABLE STANDARD .....45  
TEST PROCEDURE .....45  
TEST EQUIPMENT LIST AND DETAILS.....45  
TEST DATA .....45

**FCC §15.247(e) - POWER SPECTRAL DENSITY .....49**  
APPLICABLE STANDARD .....49  
TEST PROCEDURE .....49  
TEST EQUIPMENT LIST AND DETAILS.....49  
TEST DATA .....49

**DECLARATION OF SIMILARITY .....55**

## GENERAL INFORMATION

---

### Product Description for Equipment under Test (EUT)

The Action Electronics Co Ltd.'s product, model number: MID30801, MID30802 (FCC ID: *ATI9R3MID30801*)(the "EUT") in this report is an 8" Tablet PC, Which was measured approximately: MID30801: 21cm (L) x 15.5 cm (W) x 1.5 cm (T), MID30802: 21cm (L) x 15.5 cm (W) x 2.0 cm (T), rated input voltage: For MID30801: DC 3.7 V from lithium battery or DC 5V from adapter; for MID30802: DC 3.7 V from lithium battery or DC 5V from adapter or DC 12V from Car Charger.

#### Adapter information:

Model: ASSA1B-050200

Input: 100-240V AC, 50/60Hz, 0.45A

Output: 5.0V DC, 2000mA

*Note: The series products have four models: MID30801, T852 MID, MID30802 and T852 SBK. The differences between them are the model name and with or without docking part, model MID30802 and T852 SBK with docking part, model MID30801 and T852 MID without docking part. Compared with MID30801 and T852 MID, MID30802 and T852 SBK have worse electromagnetic compatibility performance. we selected MID30801 for fully testing, the details was explained in the attached declaration letter.*

*\* All measurement and test data in this report was gathered from production sample serial number: 130821007-1 for model MID30801, 130821007-2 for model MID30802 (Assigned by BACL.Dongguan). The EUT was received on 2013-08-23.*

### Objective

This report is prepared on behalf of *Action Electronics Co Ltd.* in accordance with Part 2-Subpart J, Part 15-Subparts A, B and C of the Federal Communications Commission rules.

The tests were performed in order to determine the compliance of the EUT with FCC Part 15-Subpart C, section 15.203, 15.205, 15.207, 15.209 and 15.247 rules.

### Related Submittal(s)/Grant(s)

FCC Part 15B JBP submissions with FCC ID: *ATI9R3MID30801*

FCC Part 15C DSS submissions with FCC ID: *ATI9R3MID30801* for Bluetooth BDR, EDR mode.

FCC Part 15C DTS submissions with FCC ID: *ATI9R3MID30801* for Bluetooth LE mode.

### Test Methodology

All measurements contained in this report were conducted with ANSI C63.4-2003, American National Standard for Methods of Measurement of Radio-Noise Emissions from Low-Voltage Electrical and Electronic Equipment in the range of 9 kHz to 40 GHz.

All emissions measurement was performed and Bay Area Compliance Laboratories Corp. (Dongguan). The radiated testing was performed at an antenna-to-EUT distance of 3 meters.

## Test Facility

The Test site used by Bay Area Compliance Laboratories Corp. (Dongguan) to collect test data is located on the No.69 Pulongcun, Puxinhu Industrial Zone, Tangxia, Dongguan, Guangdong, China

Test site at Bay Area Compliance Laboratories Corp. (Dongguan) has been fully described in reports submitted to the Federal Communication Commission (FCC). The details of these reports have been found to be in compliance with the requirements of Section 2.948 of the FCC Rules on February 02, 2012. The facility also complies with the radiated and AC line conducted test site criteria set forth in ANSI C63.4-2003.

The Federal Communications Commission has the reports on file and is listed under FCC Registration No.: 273710. The test site has been approved by the FCC for public use and is listed in the FCC Public Access Link (PAL) database.

Additionally, Bay Area Compliance Laboratories Corp. (Dongguan) is an ISO/IEC 17025 accredited laboratory, and is accredited by National Voluntary Laboratory Accredited Program (Lab Code 500069-0).



The current scope of accreditations can be found at <http://ts.nist.gov/standards/scopes/5000690.htm>

## SYSTEM TEST CONFIGURATION

### Description of Test Configuration

The system was configured for testing in testing mode, which was provided by manufacturer. For 2.4G band, 11 channels are provided to testing:

Channel	Frequency (MHz)	Channel	Frequency (MHz)
1	2412	7	2442
2	2417	8	2447
3	2422	9	2452
4	2427	10	2457
5	2432	11	2462
6	2437	/	/

For 802.11b, 802.11g, and 802.11n20 modes were tested with Channel 1, 6 and 11.

The worst-case data rates are determined to be as follows for each mode based upon investigations by measuring the average power and PSD across all data rates bandwidths, and modulations.

### EUT Exercise Software

The software: 'RFTestTool-user-4.1.apk' was used in the test, the default power was the maximum power declared by the manufacturer.

Test Mode	Test Software Version	RFTestTool-user-4.1.apk		
802.11b	Test Frequency	2412MHz	2437MHz	2462MHz
	Data Rate	1Mbps	1Mbps	1Mbps
	Power Level Setting	/	/	/
802.11g	Test Frequency	2412MHz	2437MHz	2462MHz
	Data Rate	6Mbps	6Mbps	6Mbps
	Power Level Setting	/	/	/
802.11n ht20	Test Frequency	2412MHz	2437MHz	2462MHz
	Data Rate	6.5Mbps	6.5Mbps	6.5Mbps
	Power Level Setting	/	/	/

### Equipment Modifications

No equipment modification was used.

**Support Equipment List and Details**

Manufacturer	Description	Model	Serial Number
DELL	LCD Monitor	U3011t	CN-OPH5NY-74445-16T-290L
SAMSUNG	TF Card	N/A	N/A

**External I/O Cable**

Cable Description	Shielding Type	Ferrite Core	Length (m)	From Port	To
USB Cable	Yes	Yes	1.0	Adapter	EUT
HDMI Cable	Yes	No	1.8	Monitor	EUT

**Block Diagram of Test Setup**

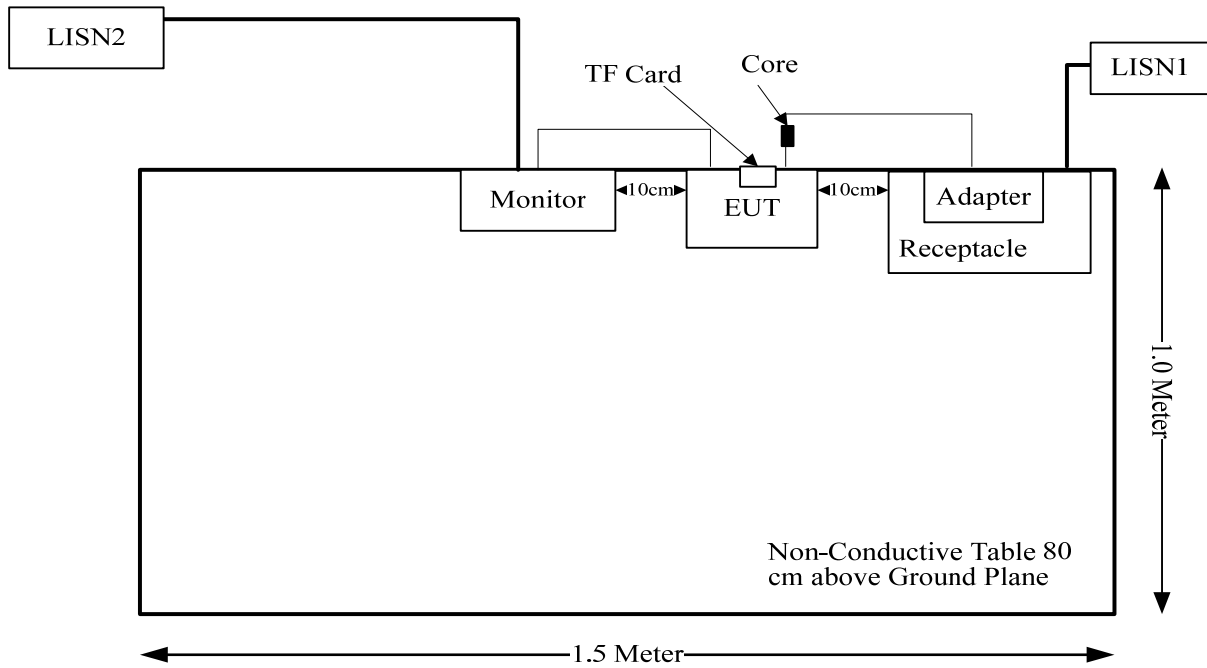

**SUMMARY OF TEST RESULTS**

<b>FCC Rules</b>	<b>Description of Test</b>	<b>Result</b>
FCC §15.247 (i) & §1.1310 & §2.1093	RF EXPOSURE	Compliance
§15.203	Antenna Requirement	Compliance
§15.207 (a)	AC Line Conducted Emissions	Compliance
§15.247(d)	Spurious Emissions at Antenna Port	Compliance
§15.205, §15.209, §15.247(d)	Spurious Emissions	Compliance
§15.247 (a)(2)	6 dB Emission Bandwidth	Compliance
§15.247(b)(3)	Maximum conducted output power	Compliance
§15.247(d)	100 kHz Bandwidth of Frequency Band Edge	Compliance
§15.247(e)	Power Spectral Density	Compliance



---

## **FCC §15.247 (i) & §1.1310 & §2.1093- RF EXPOSURE**

---

### **Applicable Standard**

According to §15.247(i) and §1.1310, systems operating under the provisions of this section shall be operated in a manner that ensure that the public is not exposed to radio frequency energy level in excess of the Commission's guideline.

According to KDB 447498 D01 Mobile Portable RF Exposure V05 Appendix A, SAR can be exempted if the output power is less than the SAR exclusion threshold:

For  $f=2450\text{MHz}$ , the output power is less 10mW at distance of 5mm.

### **Measurement Result**

Maximum conducted output power= 8.25 dBm  
SAR exclusion threshold 10 mW (10dBm) > 8.25 dBm

**So the SAR evaluation is not necessary.**

## **FCC §15.203 - ANTENNA REQUIREMENT**

---

### **Applicable Standard**

According to § 15.203, an intentional radiator shall be designed to ensure that no antenna other than that furnished by the responsible party shall be used with the device. The use of a permanently attached antenna or of an antenna that uses a unique coupling to the intentional radiator shall be considered sufficient to comply with the provisions of this section. The manufacturer may design the unit so that a broken antenna can be replaced by the user, but the user of a standard antenna jack or electrical connector is prohibited. The structure and application of the EUT were analyzed to determine compliance with section §15.203 of the rules. §15.203 state that the subject device must meet the following criteria:

- a. Antenna must be permanently attached to the unit.
- b. Antenna must use a unique type of connector to attach to the EUT.

Unit must be professionally installed, and installer shall be responsible for verifying that the correct antenna is employed with the unit.

### **Antenna Connector Construction**

The EUT has an internal antenna, which was permanently attached to the EUT, and the maximum gain is 2.0dBi, please refer to the internal photos.

**Result:** Compliance.

**FCC §15.207 (a) – AC LINE CONDUCTED EMISSIONS**

**Applicable Standard**

FCC§15.207

**Measurement Uncertainty**

Compliance or non-compliance with a disturbance limit shall be determined in the following manner:

If  $U_{lab}$  is less than or equal to  $U_{cispr}$  of Table 1, then:

- compliance is deemed to occur if no measured disturbance level exceeds the disturbance limit;
- non-compliance is deemed to occur if any measured disturbance level exceeds the disturbance limit.

If  $U_{lab}$  is greater than  $U_{cispr}$  of Table 1, then:

- compliance is deemed to occur if no measured disturbance level, increased by  $(U_{lab} - U_{cispr})$ , exceeds the disturbance limit;
- non-compliance is deemed to occur if any measured disturbance level, increased by  $(U_{lab} - U_{cispr})$ , exceeds the disturbance limit.

Based on CISPR 16-4-2-2011, measurement uncertainty of conducted disturbance at mains port using AMN at Bay Area Compliance Laboratories Corp. (Dongguan) is 3.46 dB (150 kHz to 30 MHz).

Table 1 – Values of  $U_{cispr}$

Measurement	$U_{cispr}$
Conducted disturbance at mains port using AMN (150 kHz to 30 MHz)	3.4 dB

**EUT Setup**

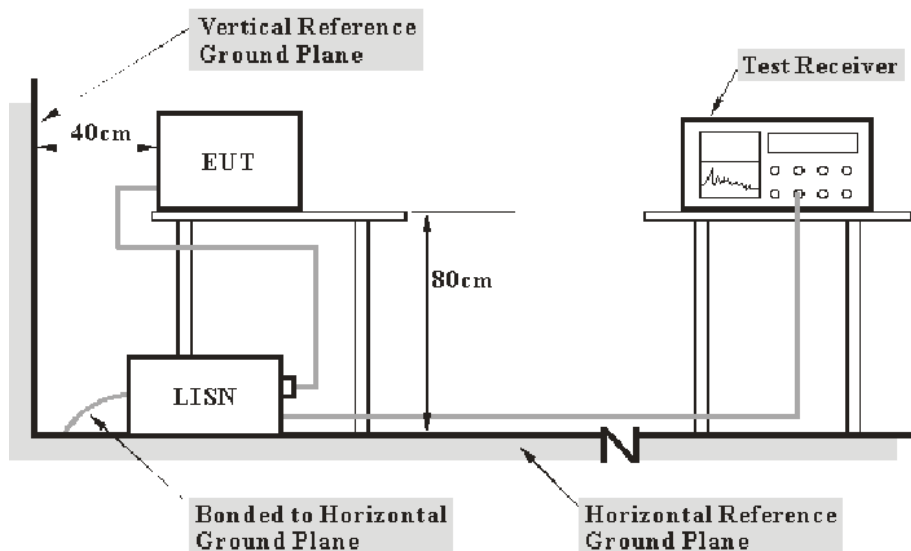

- Note: 1. Support units were connected to second LISN.  
 2. Both of LISNs (AMN) 80 cm from EUT and at the least 80 cm from other units and other metal planes support units.

The setup of EUT is according with per ANSI C63.4-2003 measurement procedure. The specification used was with the FCC Part 15.207 limits.

The spacing between the peripherals was 10 cm.

The adapter was connected to a 120 VAC/60 Hz power source

### EMI Test Receiver Setup

The EMI test receiver was set to investigate the spectrum from 150 kHz to 30 MHz.

During the conducted emission test, the EMI test receiver was set with the following configurations:

Frequency Range	IF B/W
150 kHz – 30 MHz	9 kHz

### Test Procedure

During the conducted emission test, the adapter was connected to the outlet of the first LISN and the other support equipments were connected to the outlet of the second LISN.

Maximizing procedure was performed on the six (6) highest emissions of the EUT.

All data was recorded in the Quasi-peak and average detection mode.

### Corrected Amplitude & Margin Calculation

The basic equation is as follows:

$$V_C = V_R + A_C + VDF$$

$$C_f = A_C + VDF$$

Herein,

$V_C$  (cord. Reading): corrected voltage amplitude

$V_R$ : reading voltage amplitude

$A_C$ : attenuation caused by cable loss

$VDF$ : voltage division factor of AMN

$C_f$ : Correction Factor

The “**Margin**” column of the following data tables indicates the degree of compliance within the applicable limit. For example, a margin of 7dB means the emission is 7dB below the maximum limit. The equation for margin calculation is as follows:

$$\text{Margin} = \text{Limit} - \text{Corrected Amplitude}$$

### Test Equipment List and Details

Manufacturer	Description	Model	Serial Number	Calibration Date	Calibration Due Date
R&S	EMI TEST RECIEVER	ESCS 30	830245/006	2013-1-10	2014-1-9
R&S	L.I.S.N	ESH3-Z5	843331/015	2012-9-17	2013-9-16
R&S	L.I.S.N	ESH3-Z5	100113	2012-11-29	2013-11-28
BACL	Test Software	BACL-EMC	V1.0-2010	N/A	N/A

\* **Statement of Traceability:** Bay Area Compliance Laboratories Corp. (Dongguan) attests that all calibrations have been performed in accordance to NVLAP requirements, traceable to National Primary Standards and International System of Units (SI).

### Test Results Summary

According to the recorded data in following table, the EUT complied with the FCC Part 15.207, with the worst margin reading of:

**21.70 dB at 1.580 MHz** in the **Line** conducted mode

### Test Data

#### Environmental Conditions

<b>Temperature:</b>	27.3 °C
<b>Relative Humidity:</b>	61 %
<b>ATM Pressure:</b>	100.5 kPa

*The testing was performed by Leon Chen on 2013-09-11.*

Test Mode: Transmitting

120 V, 60 Hz, Line:

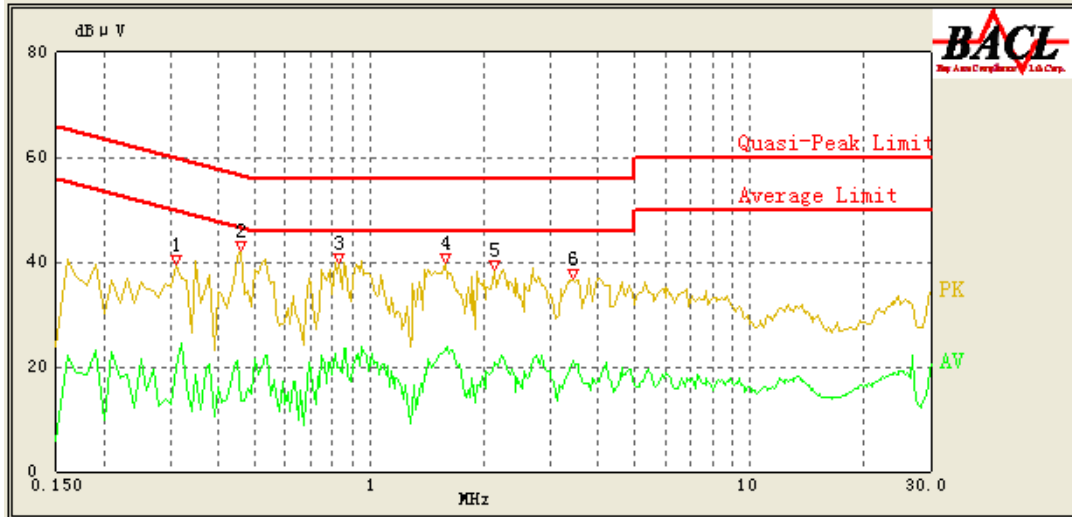

Frequency (MHz)	Cord. Reading (dBμV)	Correction Factor (dB)	Limit (dBμV)	Margin (dB)	Detector (PK/AV/QP)
0.310	35.65	0.23	59.97	24.32	QP
0.310	20.00	0.23	49.97	29.97	AV
0.460	32.14	0.21	56.69	24.55	QP
0.460	13.34	0.21	46.69	33.35	AV
0.830	34.06	0.22	56.00	21.94	QP
0.830	19.82	0.22	46.00	26.18	AV
1.580	34.30	0.25	56.00	21.70	QP
1.580	23.25	0.25	46.00	22.75	AV
2.130	30.26	0.28	56.00	25.74	QP
2.130	20.85	0.28	46.00	25.15	AV
3.450	30.78	0.33	56.00	25.22	QP
3.450	21.21	0.33	46.00	24.79	AV

**120 V, 60 Hz, Neutral:**



Frequency (MHz)	Cord. Reading (dBμV)	Correction Factor (dB)	Limit (dBμV)	Margin (dB)	Detector (PK/AV/QP)
0.260	36.92	0.24	61.43	24.51	QP
0.260	22.88	0.24	51.43	28.55	AV
0.530	32.28	0.21	56.00	23.72	QP
0.530	20.21	0.21	46.00	25.79	AV
0.780	29.60	0.22	56.00	26.40	QP
0.780	21.21	0.22	46.00	24.79	AV
1.720	26.97	0.26	56.00	29.03	QP
1.730	17.33	0.26	46.00	28.67	AV
3.070	24.45	0.31	56.00	31.55	QP
3.070	14.10	0.31	46.00	31.90	AV
13.200	33.18	0.98	60.00	26.82	QP
13.290	26.15	0.98	50.00	23.85	AV

**FCC §15.209, §15.205 & §15.247(d) - SPURIOUS EMISSIONS**

**Applicable Standard**

FCC §15.247 (d); §15.209; §15.205;

**Measurement Uncertainty**

Compliance or non-compliance with a disturbance limit shall be determined in the following manner:

If  $U_{lab}$  is less than or equal to  $U_{cispr}$  of Table 2, then:

- compliance is deemed to occur if no measured disturbance level exceeds the disturbance limit;
- non-compliance is deemed to occur if any measured disturbance level exceeds the disturbance limit.

If  $U_{lab}$  is greater than  $U_{cispr}$  of Table 2, then:

- compliance is deemed to occur if no measured disturbance level, increased by  $(U_{lab} - U_{cispr})$ , exceeds the disturbance limit;
- non-compliance is deemed to occur if any measured disturbance level, increased by  $(U_{lab} - U_{cispr})$ , exceeds the disturbance limit.

Based on CISPR 16-4-2-2011, measurement uncertainty of radiated emission at a distance of 3m at Bay Area Compliance Laboratories Corp. (Dongguan) is:

- 30M~200MHz: 5.0 dB
- 200M~1GHz: 6.2 dB
- 1G~6GHz: 4.45 dB
- 6G~18GHz: 5.23 dB

Table 2 – Values of  $U_{cispr}$

Measurement	$U_{cispr}$
Radiated disturbance (electric field strength at an OATS or in a SAC) (30 MHz to 1000 MHz)	6.3 dB
Radiated disturbance (electric field strength in a FAR) (1 GHz to 6 GHz)	5.2 dB
Radiated disturbance (electric field strength in a FAR) (6 GHz to 18 GHz)	5.5 dB

**EUT Setup**

**Below 1GHz:**

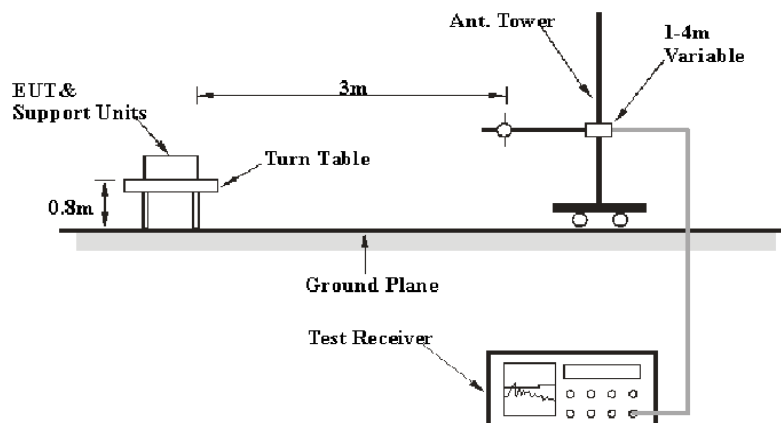



**Above 1GHz:**

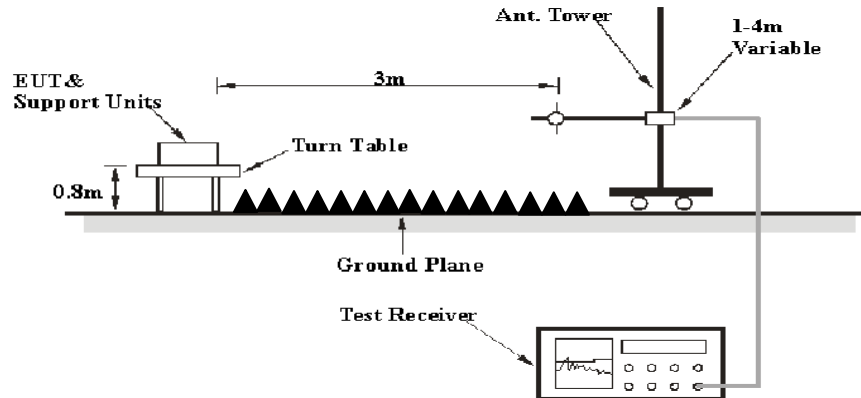

The radiated emission tests were performed in the 3 meters chamber test site, using the setup accordance with the ANSI C63.4-2003. The specification used was the FCC 15.209, and FCC 15.247 limits.

The external I/O cables were draped along the test table and formed a bundle 30 to 40 cm long in the middle.

The spacing between the peripherals was 10 cm.

The adapter was connected to a 120 VAC/60 Hz power source

**EMI Test Receiver & Spectrum Analyzer Setup**

The system was investigated from 30 MHz to 25 GHz.

During the radiated emission test, the EMI test receiver & Spectrum Analyzer Setup were set with the following configurations:

Frequency Range	RBW	Video B/W	IF B/W	Detector
30MHz – 1000 MHz	120 kHz	300 kHz	120kHz	QP
Above 1 GHz	1MHz	3 MHz	/	PK
	1MHz	10 Hz	/	Ave.

**Test Procedure**

During the radiated emission test, the adapter was connected to the first AC floor outlet and the other support equipments were connected to the second AC floor outlet.

Maximizing procedure was performed on the highest emissions to ensure that the EUT complied with all installation combinations.

Data was recorded in Quasi-peak detection mode for frequency range of 30 MHz-1 GHz, peak and Average detection modes for frequencies above 1 GHz.

## Corrected Amplitude & Margin Calculation

The Corrected Amplitude is calculated by adding the Antenna Loss and Cable Loss, and subtracting the Amplifier Gain from the Meter Reading. The basic equation is as follows:

$$\text{Corrected Amplitude} = \text{Meter Reading} + \text{Antenna Loss} + \text{Cable Loss} - \text{Amplifier Gain}$$

The “**Margin**” column of the following data tables indicates the degree of compliance with the applicable limit. For example, a margin of 7dB means the emission is 7dB below the limit. The equation for margin calculation is as follows:

$$\text{Margin} = \text{Limit} - \text{Corrected Amplitude}$$

## Test Equipment List and Details

Manufacturer	Description	Model	Serial Number	Calibration Date	Calibration Due Date
R&S	EMI TEST RECEIVER	ESCI	100224	2013-5-6	2014-5-5
Sunol Sciences	Antenna	JB3	A060611-1	2011-9-6	2014-9-5
HP	HP AMPLIFIER	8447E	2434A02181	N/A	N/A
R&S	Spectrum analyzer	FSEM 30	849016/001	2012-12-7	2013-12-6
ETS LINDGREN	horn antenna	3115	000 527 35	2012-9-6	2015-9-5
Mini-Circuit	Amplifier	ZVA-213-S+	054201245	N/A	N/A
R&S	Spectrum analyzer	FSP 38	100478	2013-6-16	2014-6-15
Ducommun Technologies	Horn antenna	ARH-4223-02	1007726-02-1304	2013-6-16	2014-6-15
QUINSTAR	Amplifier	QLW-18045536-J0	15964001001	N/A	N/A

\* **Statement of Traceability:** Bay Area Compliance Laboratories Corp. (Dongguan) attests that all calibrations have been performed in accordance to NVLAP requirements, traceable to National Primary Standards and International System of Units (SI).

## Test Results Summary

According to the recorded data in following table, the EUT complied with the FCC Title 47, Part 15, Section 15.205, 15.209 and 15.247, with the worst margin reading of:

**8.54 dB at 2483.5 MHz in the Vertical polarization for 802.11n20 Mode**

**Test Data**

**Environmental Conditions**

<b>Temperature:</b>	26.3 °C
<b>Relative Humidity:</b>	64 %
<b>ATM Pressure:</b>	100.3kPa

*The testing was performed by Leon Chen on 2013-09-17.*

Mode: Transmitting  
802.11b Mode

Frequency (MHz)	Receiver		Rx Antenna		Cable loss (dB)	Amplifier Gain (dB)	Corrected Amplitude (dBµV/m)	FCC 15.247	
	Reading (dBµV)	Detector (PK/QP/AV)	Polar (H/V)	Factor (dB)				Limit (dBµV/m)	Margin (dB)
Low Channel: 2412 MHz									
2412	69.09	PK	H	25.67	3.93	0.00	98.69	N/A	N/A
2412	64.57	AV	H	25.67	3.93	0.00	94.17	N/A	N/A
2412	66.56	PK	V	25.67	3.93	0.00	96.16	N/A	N/A
2412	62.13	AV	V	25.67	3.93	0.00	91.73	N/A	N/A
2390	28.84	PK	V	25.61	3.84	0.00	58.29	74.00	15.71
2390	15.08	AV	V	25.61	3.84	0.00	44.53	54.00	9.47
4824	34.61	PK	V	30.64	4.73	27.26	42.72	74.00	31.28
4824	24.71	AV	V	30.64	4.73	27.26	32.82	54.00	21.18
7236	31.35	PK	V	34.17	6.56	26.36	45.72	74.00	28.28
7236	18.34	AV	V	34.17	6.56	26.36	32.71	54.00	21.29
9648	31.84	PK	V	36.06	8.70	26.06	50.54	74.00	23.46
9648	18.09	AV	V	36.06	8.70	26.06	36.79	54.00	17.21
3618	33.62	PK	V	29.06	5.01	27.43	40.26	74.00	33.74
3618	21.91	AV	V	29.06	5.01	27.43	28.55	54.00	25.45
276	32.58	QP	V	13.75	2.00	21.51	26.82	46.00	19.18
Middle Channel: 2437 MHz									
2437	68.9	PK	H	25.74	3.98	0.00	98.62	N/A	N/A
2437	64.63	AV	H	25.74	3.98	0.00	94.35	N/A	N/A
2437	66.66	PK	V	25.74	3.98	0.00	96.38	N/A	N/A
2437	61.91	AV	V	25.74	3.98	0.00	91.63	N/A	N/A
4874	34.42	PK	V	30.77	4.76	27.26	42.69	74.00	31.31
4874	24.7	AV	V	30.77	4.76	27.26	32.97	54.00	21.03
7311	31.48	PK	V	34.35	6.70	26.51	46.02	74.00	27.98
7311	18.19	AV	V	34.35	6.70	26.51	32.73	54.00	21.27
9748	32.06	PK	V	36.30	8.60	25.68	51.28	74.00	22.72
9748	18.34	AV	V	36.30	8.60	25.68	37.56	54.00	16.44
1720	32.08	PK	V	24.04	3.25	26.97	32.40	74.00	41.60
1720	21.43	AV	V	24.04	3.25	26.97	21.75	54.00	32.25
3618	33.69	PK	V	29.06	5.01	27.43	40.33	74.00	33.67
3618	21.94	AV	V	29.06	5.01	27.43	28.58	54.00	25.42
276.1	32.37	QP	V	13.75	2.00	21.51	26.61	46.00	19.39
High Channel: 2462 MHz									
2462	69.09	PK	H	25.80	3.93	0.00	98.82	N/A	N/A
2462	64.59	AV	H	25.80	3.93	0.00	94.32	N/A	N/A
2462	66.72	PK	V	25.80	3.93	0.00	96.45	N/A	N/A
2462	61.93	AV	V	25.80	3.93	0.00	91.66	N/A	N/A
2483.5	28.78	PK	V	25.86	3.80	0.00	58.44	74.00	15.56
2483.5	15.1	AV	V	25.86	3.80	0.00	44.76	54.00	9.24
4924	34.45	PK	V	30.90	4.70	27.27	42.78	74.00	31.22
4924	24.51	AV	V	30.90	4.70	27.27	32.84	54.00	21.16
7386	31.61	PK	V	34.53	6.84	26.66	46.32	74.00	27.68
7386	18.16	AV	V	34.53	6.84	26.66	32.87	54.00	21.13
9848	31.9	PK	V	36.54	8.49	25.49	51.44	74.00	22.56
9848	18.16	AV	V	36.54	8.49	25.49	37.70	54.00	16.30
3618	33.78	PK	V	29.06	5.01	27.43	40.42	74.00	33.58
3618	22.18	AV	V	29.06	5.01	27.43	28.82	54.00	25.18
276	32.81	QP	V	13.75	2.00	21.51	27.05	46.00	18.95

\*Within measurement uncertainty!

802.11g Mode

Frequency (MHz)	Receiver		Rx Antenna		Cable loss (dB)	Amplifier Gain (dB)	Corrected Amplitude (dBµV/m)	FCC 15.247	
	Reading (dBµV)	Detector (PK/QP/AV)	Polar (H/V)	Factor (dB)				Limit (dBµV/m)	Margin (dB)
Low Channel: 2412 MHz									
2412	72.82	PK	H	25.67	3.93	0.00	102.42	N/A	N/A
2412	60.15	AV	H	25.67	3.93	0.00	89.75	N/A	N/A
2412	69.47	PK	V	25.67	3.93	0.00	99.07	N/A	N/A
2412	57.01	AV	V	25.67	3.93	0.00	86.61	N/A	N/A
2390	30.4	PK	V	25.61	3.84	0.00	59.85	74.00	14.15
2390	15.53	AV	V	25.61	3.84	0.00	44.98	54.00	9.02
4824	35.14	PK	V	30.64	4.73	27.26	43.25	74.00	30.75
4824	20.86	AV	V	30.64	4.73	27.26	28.97	54.00	25.03
7236	32.45	PK	V	34.17	6.56	26.36	46.82	74.00	27.18
7236	17.69	AV	V	34.17	6.56	26.36	32.06	54.00	21.94
9648	32.94	PK	V	36.06	8.70	26.06	51.64	74.00	22.36
9648	17.69	AV	V	36.06	8.70	26.06	36.39	54.00	17.61
3618	32.19	PK	V	29.06	5.01	27.43	38.83	74.00	35.17
3618	18.01	AV	V	29.06	5.01	27.43	24.65	54.00	29.35
276	32.49	QP	V	13.75	2.00	21.51	26.73	46.00	19.27
Middle Channel: 2437 MHz									
2437	72.72	PK	H	25.74	3.98	0.00	102.44	N/A	N/A
2437	60.31	AV	H	25.74	3.98	0.00	90.03	N/A	N/A
2437	69.68	PK	V	25.74	3.98	0.00	99.40	N/A	N/A
2437	56.99	AV	V	25.74	3.98	0.00	86.71	N/A	N/A
4874	35.02	PK	V	30.77	4.76	27.26	43.29	74.00	30.71
4874	20.69	AV	V	30.77	4.76	27.26	28.96	54.00	25.04
7311	32.47	PK	V	34.35	6.70	26.51	47.01	74.00	26.99
7311	17.55	AV	V	34.35	6.70	26.51	32.09	54.00	21.91
9748	33.15	PK	V	36.30	8.60	25.68	52.37	74.00	21.63
9748	17.74	AV	V	36.30	8.60	25.68	36.96	54.00	17.04
1720	32.49	PK	V	24.04	3.25	26.97	32.81	74.00	41.19
1720	20.68	AV	V	24.04	3.25	26.97	21.00	54.00	33.00
3618	32.43	PK	V	29.06	5.01	27.43	39.07	74.00	34.93
3618	18.25	AV	V	29.06	5.01	27.43	24.89	54.00	29.11
276	32.67	QP	V	13.75	2.00	21.51	26.91	46.00	19.09
High Channel: 2462 MHz									
2462	72.6	PK	H	25.80	3.93	0.00	102.33	N/A	N/A
2462	60.21	AV	H	25.80	3.93	0.00	89.94	N/A	N/A
2462	69.53	PK	V	25.80	3.93	0.00	99.26	N/A	N/A
2462	56.72	AV	V	25.80	3.93	0.00	86.45	N/A	N/A
2483.5	30.16	PK	V	25.86	3.80	0.00	59.82	74.00	14.18
2483.5	15.63	AV	V	25.86	3.80	0.00	45.29	54.00	8.71
4924	35.09	PK	V	30.90	4.70	27.27	43.42	74.00	30.58
4924	20.66	AV	V	30.90	4.70	27.27	28.99	54.00	25.01
7386	32.63	PK	V	34.53	6.84	26.66	47.34	74.00	26.66
7386	17.59	AV	V	34.53	6.84	26.66	32.30	54.00	21.70
9848	33.19	PK	V	36.54	8.49	25.49	52.73	74.00	21.27
9848	17.85	AV	V	36.54	8.49	25.49	37.39	54.00	16.61
3618	32.48	PK	V	29.06	5.01	27.43	39.12	74.00	34.88
3618	18.15	AV	V	29.06	5.01	27.43	24.79	54.00	29.21
276	32.51	QP	V	13.75	2.00	21.51	26.75	46.00	19.25

802.11 n20 Mode

Frequency (MHz)	Receiver		Rx Antenna		Cable loss (dB)	Amplifier Gain (dB)	Corrected Amplitude (dBµV/m)	FCC 15.247	
	Reading (dBµV)	Detector (PK/QP/AV)	Polar (H/V)	Factor (dB)				Limit (dBµV/m)	Margin (dB)
Low Channel: 2412 MHz									
2412	73.33	PK	H	25.67	3.93	0.00	102.93	N/A	N/A
2412	61.06	AV	H	25.67	3.93	0.00	90.66	N/A	N/A
2412	69.68	PK	V	25.67	3.93	0.00	99.28	N/A	N/A
2412	57.61	AV	V	25.67	3.93	0.00	87.21	N/A	N/A
2390	30.28	PK	V	25.61	3.84	0.00	59.73	74.00	14.27
2390	15.74	AV	V	25.61	3.84	0.00	45.19	54.00	8.81
4824	34.59	PK	V	30.64	4.73	27.26	42.70	74.00	31.30
4824	20.87	AV	V	30.64	4.73	27.26	28.98	54.00	25.02
7236	31	PK	V	34.17	6.56	26.36	45.37	74.00	28.63
7236	17.76	AV	V	34.17	6.56	26.36	32.13	54.00	21.87
9648	31.18	PK	V	36.06	8.70	26.06	49.88	74.00	24.12
9648	18.11	AV	V	36.06	8.70	26.06	36.81	54.00	17.19
3618	32.39	PK	V	29.06	5.01	27.43	39.03	74.00	34.97
3618	18.07	AV	V	29.06	5.01	27.43	24.71	54.00	29.29
276	34.13	QP	V	13.75	2.00	21.51	28.37	46.00	17.63
Middle Channel: 2437 MHz									
2437	73.31	PK	H	25.74	3.98	0.00	103.03	N/A	N/A
2437	61.33	AV	H	25.74	3.98	0.00	91.05	N/A	N/A
2437	69.7	PK	V	25.74	3.98	0.00	99.42	N/A	N/A
2437	57.57	AV	V	25.74	3.98	0.00	87.29	N/A	N/A
4874	34.56	PK	V	30.77	4.76	27.26	42.83	74.00	31.17
4874	20.71	AV	V	30.77	4.76	27.26	28.98	54.00	25.02
7311	31.29	PK	V	34.35	6.70	26.51	45.83	74.00	28.17
7311	17.48	AV	V	34.35	6.70	26.51	32.02	54.00	21.98
9748	31.2	PK	V	36.30	8.60	25.68	50.42	74.00	23.58
9748	18.14	AV	V	36.30	8.60	25.68	37.36	54.00	16.64
1720	32.22	PK	V	24.04	3.25	26.97	32.54	74.00	41.46
1720	17.93	AV	V	24.04	3.25	26.97	18.25	54.00	35.75
3618	32.64	PK	V	29.06	5.01	27.43	39.28	74.00	34.72
3618	18.12	AV	V	29.06	5.01	27.43	24.76	54.00	29.24
276	34.37	QP	V	13.75	2.00	21.51	28.61	46.00	17.39
High Channel: 2462 MHz									
2462	73.32	PK	H	25.80	3.93	0.00	103.05	N/A	N/A
2462	61.34	AV	H	25.80	3.93	0.00	91.07	N/A	N/A
2462	69.92	PK	V	25.80	3.93	0.00	99.65	N/A	N/A
2462	57.56	AV	V	25.80	3.93	0.00	87.29	N/A	N/A
2483.5	30.02	PK	V	25.86	3.80	0.00	59.68	74.00	14.32
2483.5	15.8	AV	V	25.86	3.80	0.00	45.46	54.00	8.54
4924	34.37	PK	V	30.90	4.70	27.27	42.70	74.00	31.30
4924	20.69	AV	V	30.90	4.70	27.27	29.02	54.00	24.98
7386	31.18	PK	V	34.53	6.84	26.66	45.89	74.00	28.11
7386	17.49	AV	V	34.53	6.84	26.66	32.20	54.00	21.80
9848	31.47	PK	V	36.54	8.49	25.49	51.01	74.00	22.99
9848	18.19	AV	V	36.54	8.49	25.49	37.73	54.00	16.27
3618	32.6	PK	V	29.06	5.01	27.43	39.24	74.00	34.76
3618	18.26	AV	V	29.06	5.01	27.43	24.90	54.00	29.10
276	34.28	QP	V	13.75	2.00	21.51	28.52	46.00	17.48

### Conducted Spurious Emissions at Antenna Port

#### 802.11b Low Channel

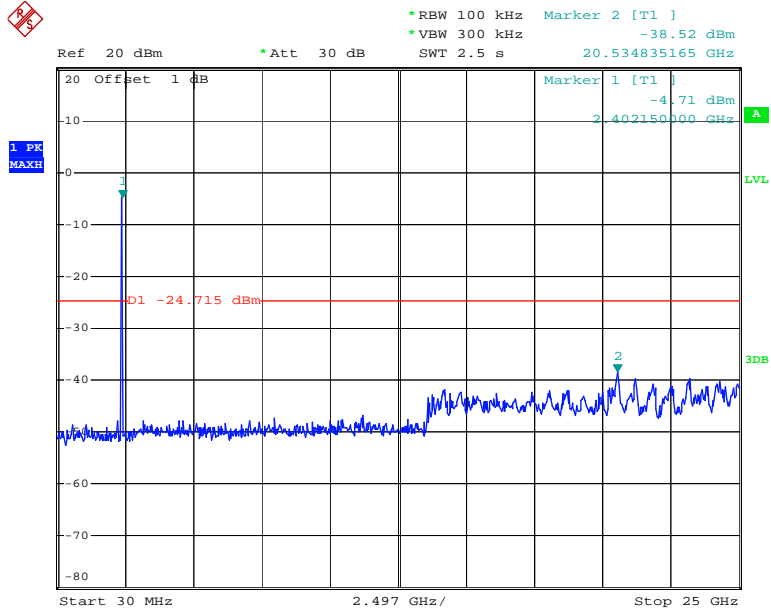

Date: 17.SEP.2013 16:58:11

#### 802.11b Middle Channel

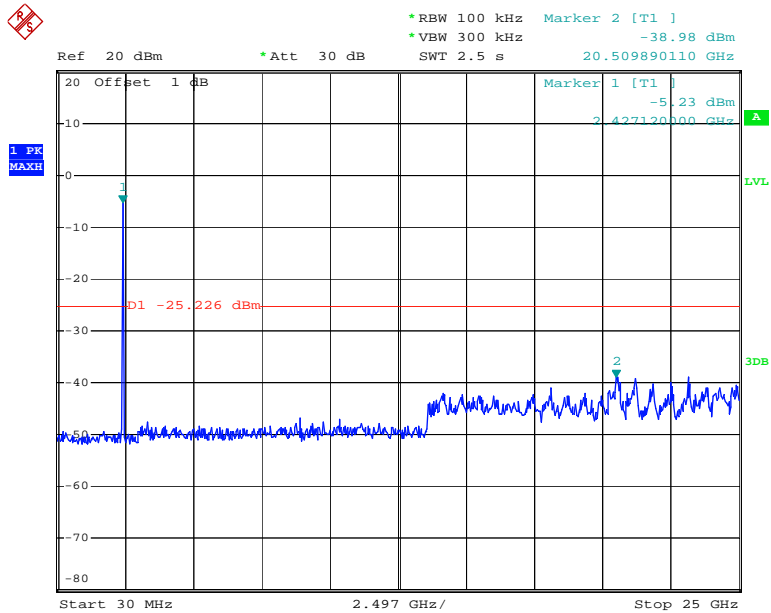

Date: 17.SEP.2013 17:29:33

### 802.11b High Channel

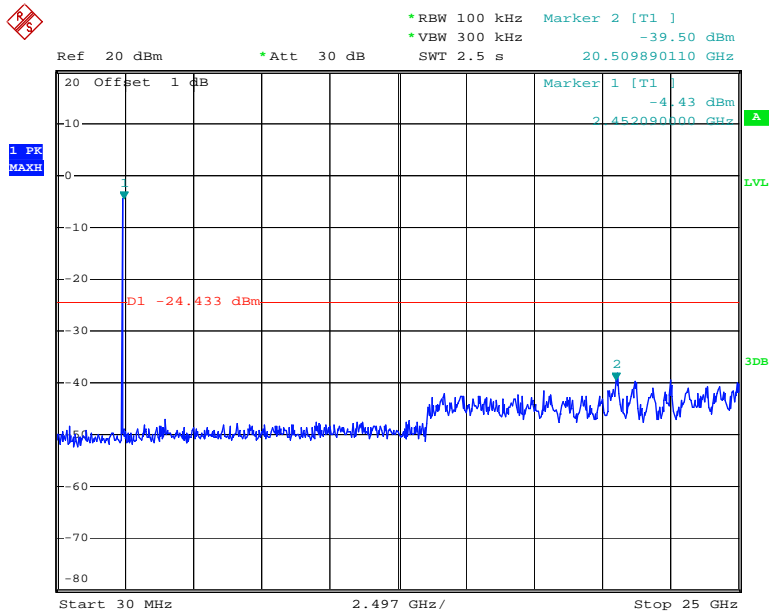

Date: 17.SEP.2013 17:34:46

### 802.11g Low Channel

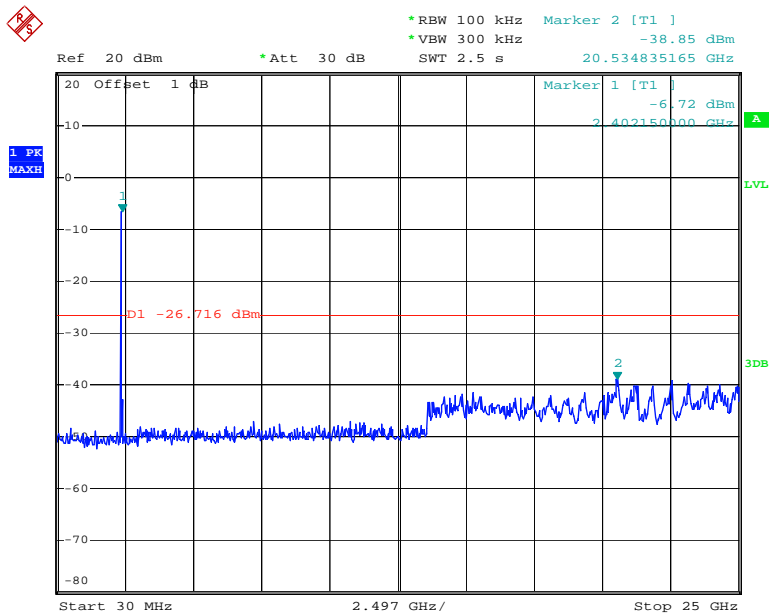

Date: 17.SEP.2013 17:02:10



### 802.11g Middle Channel

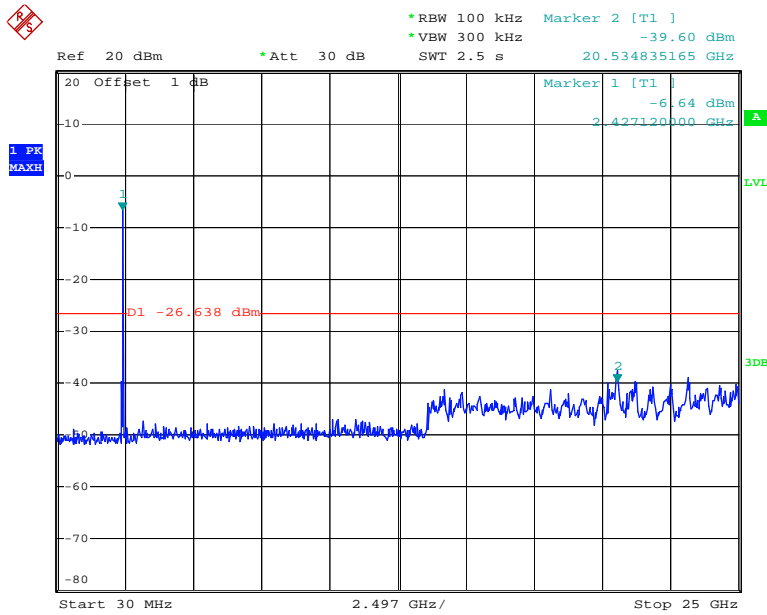

Date: 17.SEP.2013 17:03:45

### 802.11g High Channel

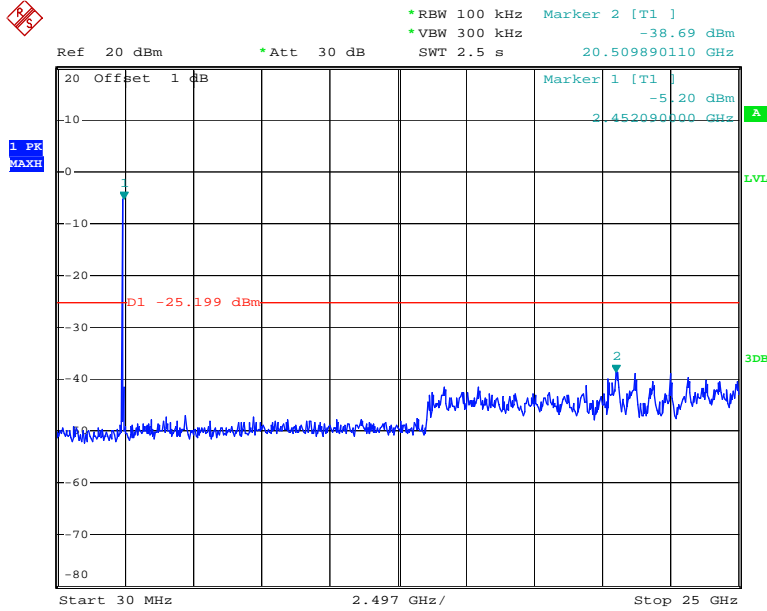

Date: 17.SEP.2013 17:05:08

### 802.11n20 Low Channel

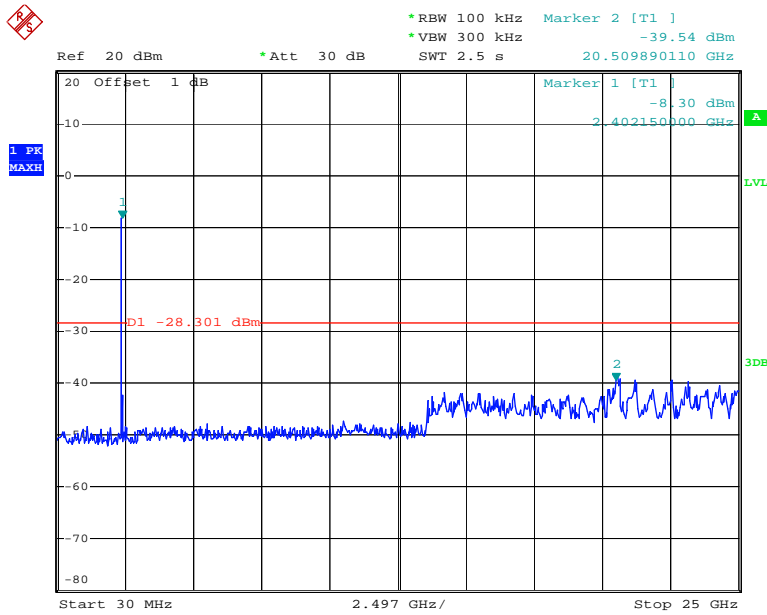

Date: 17.SEP.2013 17:37:08

### 802.11n20 Middle Channel

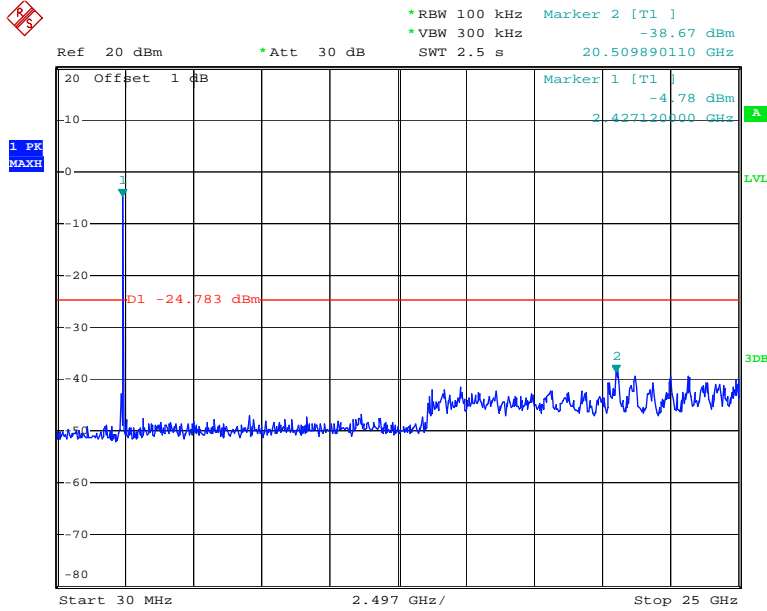

Date: 17.SEP.2013 17:09:00

### 802.11n20 High Channel

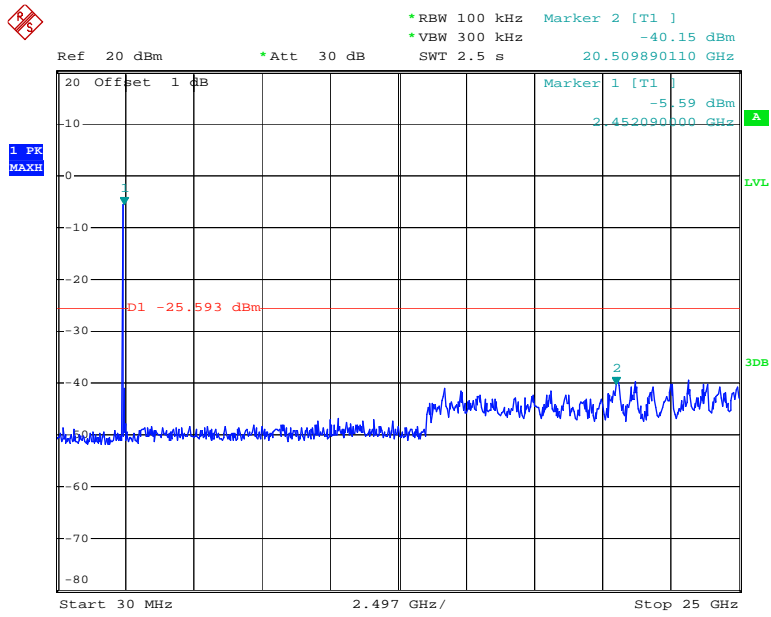

Date: 17.SEP.2013 17:10:40

## FCC §15.247(a) (2) – 6 dB EMISSION BANDWIDTH

### Applicable Standard

Systems using digital modulation techniques may operate in the 902–928 MHz, 2400–2483.5 MHz, and 5725–5850 MHz bands. The minimum 6 dB bandwidth shall be at least 500 kHz.

### Test Procedure

1. Check the calibration of the measuring instrument using either an internal calibrator or a known signal from an external generator.
2. Position the EUT without connection to measurement instrument. Turn on the EUT and connect it to measurement instrument. Then set it to any one convenient frequency within its operating range. Set a reference level on the measuring instrument equal to the highest peak value.
3. Measure the frequency difference of two frequencies that were attenuated 6 dB from the reference level. Record the frequency difference as the emission bandwidth.
4. Repeat above procedures until all frequencies measured were complete.

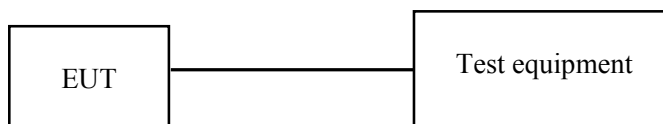

### Test Equipment List and Details

Manufacturer	Description	Model	Serial Number	Calibration Date	Calibration Due Date
R&S	Spectrum analyzer	FSP 38	100478	2013-6-16	2014-6-15

\* **Statement of Traceability:** Bay Area Compliance Laboratories Corp. (Dongguan) attests that all calibrations have been performed in accordance to NVLAP requirements, traceable to National Primary Standards and International System of Units (SI).

### Test Data

#### Environmental Conditions

<b>Temperature:</b>	26.2 °C
<b>Relative Humidity:</b>	59 %
<b>ATM Pressure:</b>	100.3 kPa

*The testing was performed by Leon Chen on 2013-09-17.*

**Test Result:** Pass.

Please refer to the following tables and plots.

Test mode	Channel	Frequency	6 dB Bandwidth	Limit
		(MHz)	(MHz)	(kHz)
802.11b mode	Low	2412	8.11	>500
	Middle	2437	7.63	>500
	High	2462	7.67	>500
802.11g mode	Low	2412	15.54	>500
	Middle	2437	15.18	>500
	High	2462	15.10	>500
802.11n20 mode	Low	2412	15.42	>500
	Middle	2437	15.14	>500
	High	2462	15.10	>500

**802.11b Low Channel**

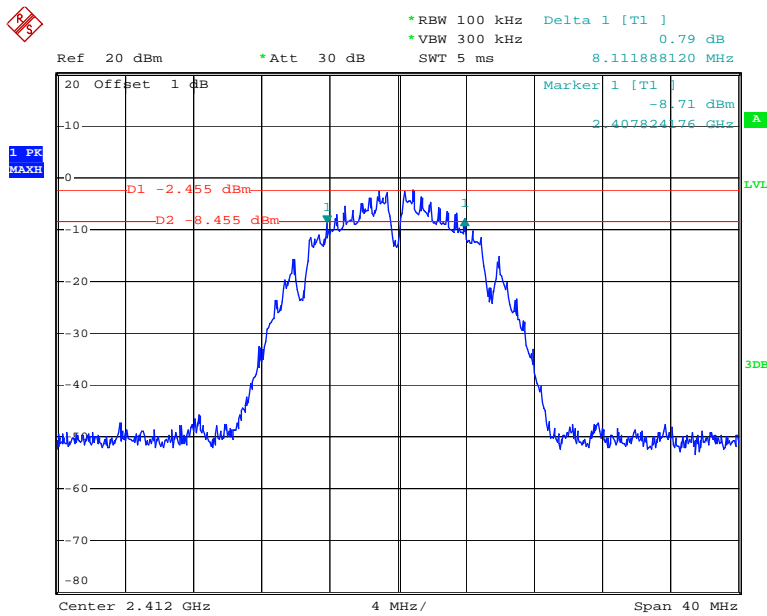

Date: 17.SEP.2013 16:57:25

### 802.11b Middle Channel

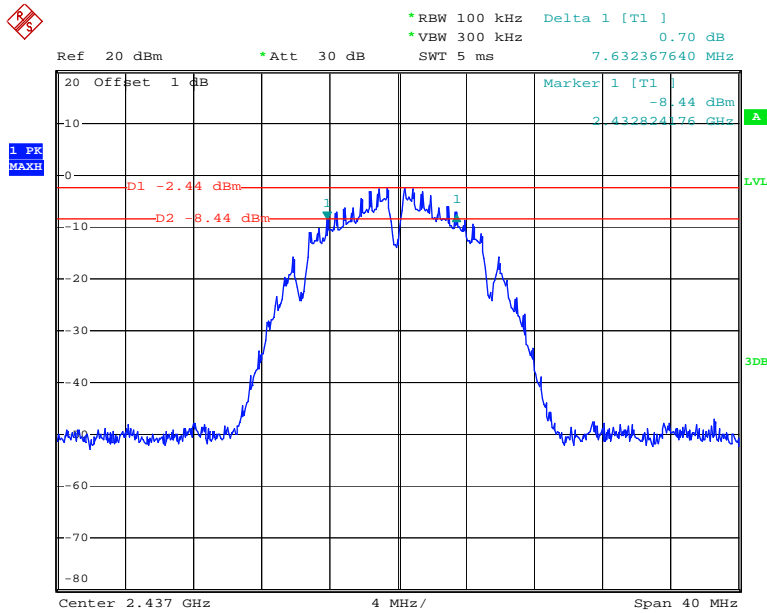

Date: 17.SEP.2013 17:28:47

### 802.11b High Channel

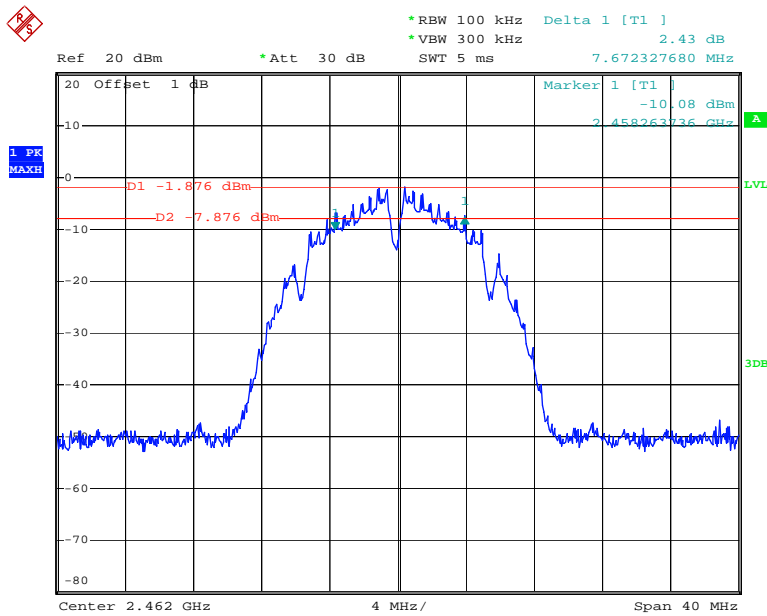

Date: 17.SEP.2013 17:34:04

### 802.11g Low Channel

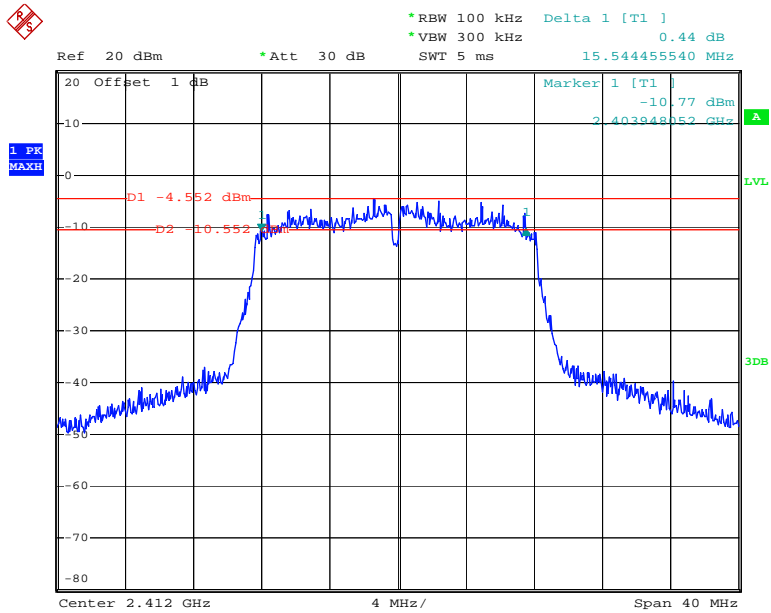

Date: 17.SEP.2013 17:01:19

### 802.11g Middle Channel

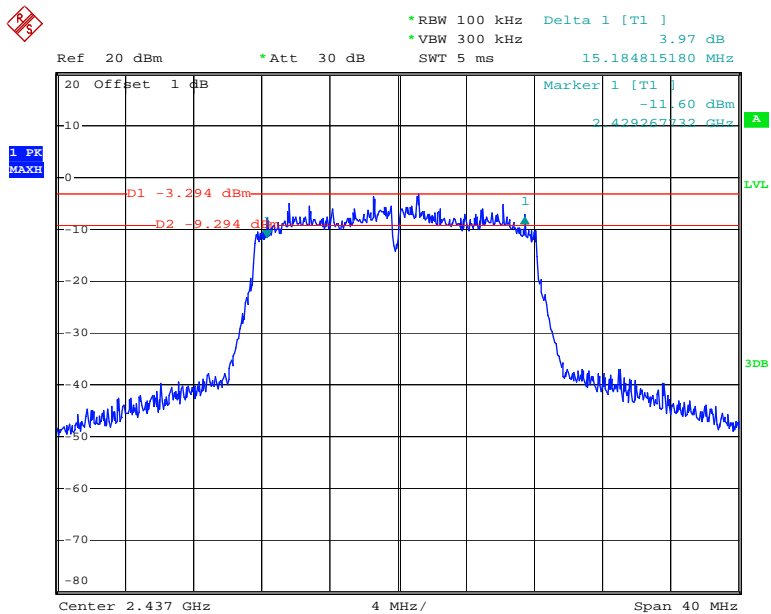

Date: 17.SEP.2013 17:02:49

### 802.11g High Channel

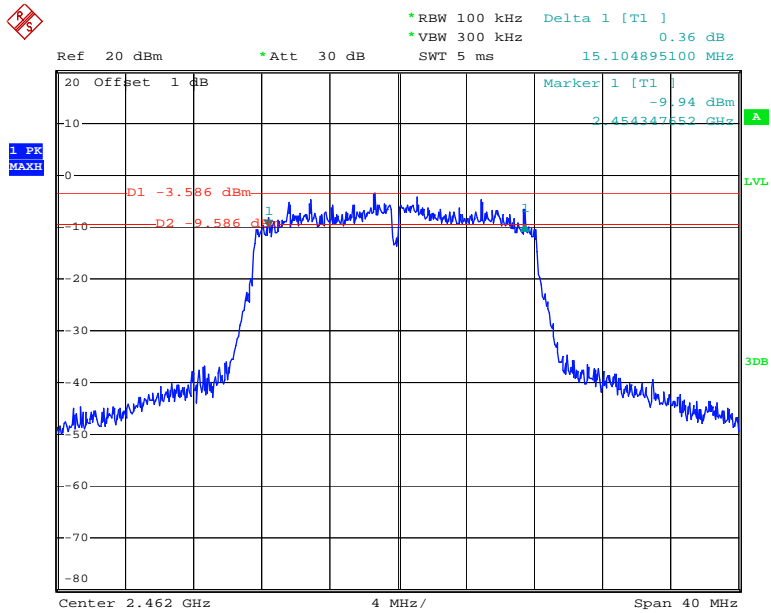

Date: 17.SEP.2013 17:04:06

### 802.11n20 Low Channel

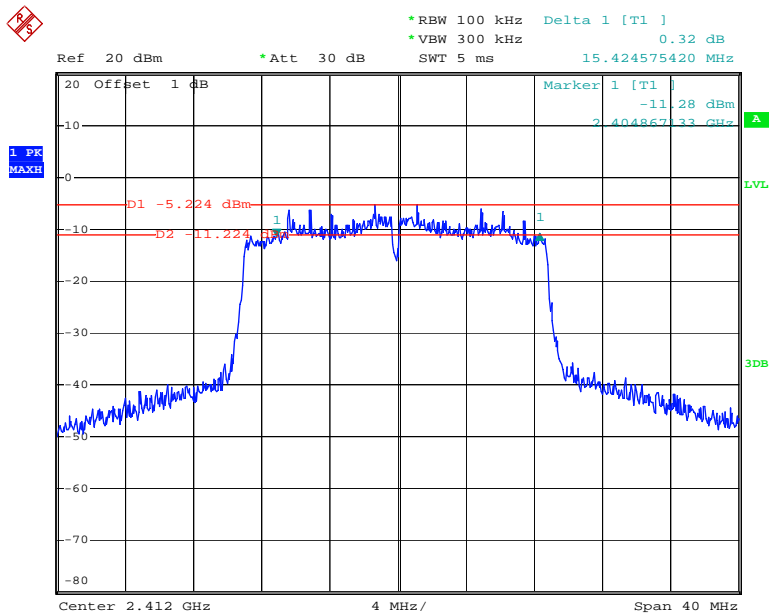

Date: 17.SEP.2013 17:36:20



### 802.11n20 Middle Channel

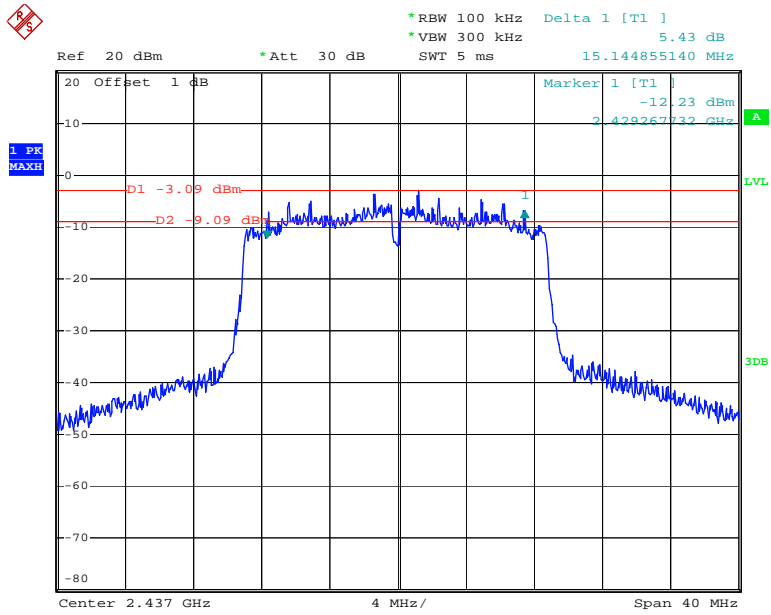

Date: 17.SEP.2013 17:08:12

### 802.11n20 High Channel

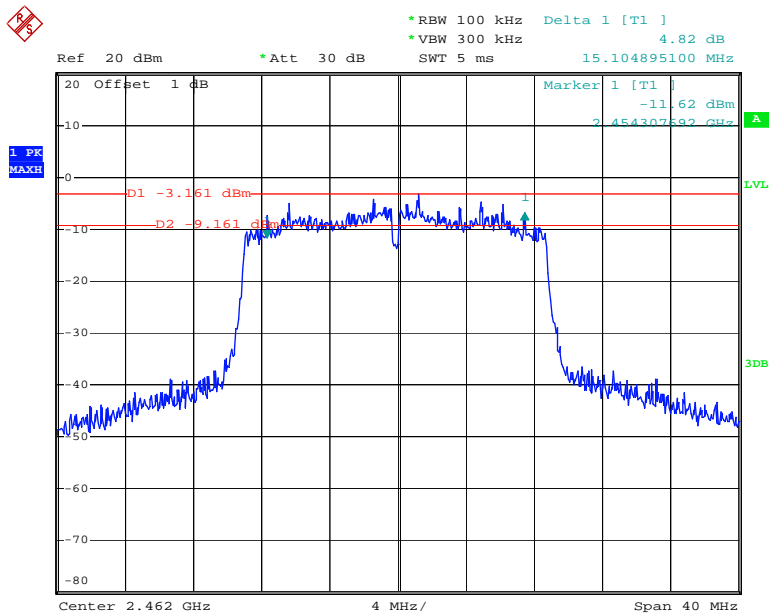

Date: 17.SEP.2013 17:09:46

## **FCC §15.247(b) (3) - MAXIMUM CONDUCTED OUTPUT POWER**

### **Applicable Standard**

According to FCC §15.247(b) (3), for systems using digital modulation in the 902-928 MHz, 2400-2483.5 MHz, and 5725-5850 MHz bands: 1 Watt. As an alternative to a peak power measurement, compliance with the one Watt limit can be based on a measurement of the maximum conducted output power. Maximum Conducted Output Power is defined as the total transmit power delivered to all antennas and antenna elements averaged across all symbols in the signaling alphabet when the transmitter is operating at its maximum power control level. Power must be summed across all antennas and antenna elements. The average must not include any time intervals during which the transmitter is off or is transmitting at a reduced power level. If multiple modes of operation are possible (e.g., alternative modulation methods), the maximum conducted output power is the highest total transmit power occurring in any mode.

### **Test Procedure**

1. According to KDB 558074 D01 DTS Meas Guidance v03r01, place the EUT on a bench and set it in transmitting mode.
2. Remove the antenna from the EUT and then connect a low loss RF cable from the antenna port to a spectrum Analyzer.
3. Add a correction factor to the display.

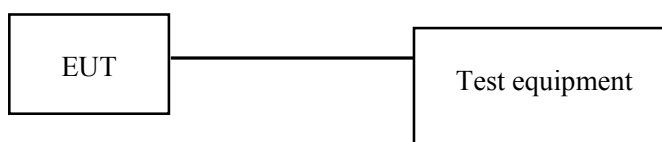

### **Test Equipment List and Details**

Manufacturer	Description	Model	Serial Number	Calibration Date	Calibration Due Date
R&S	Spectrum analyzer	FSP 38	100478	2013-6-16	2014-6-15

\* **Statement of Traceability:** Bay Area Compliance Laboratories Corp. (Dongguan) attests that all calibrations have been performed in accordance to NVLAP requirements, traceable to National Primary Standards and International System of Units (SI).

**Test Data**

**Environmental Conditions**

<b>Temperature:</b>	26.2~27.8 °C
<b>Relative Humidity:</b>	56~65 %
<b>ATM Pressure:</b>	99~100.6 kPa

*The testing was performed by Leon Chen from 2013-11-09.*

*Test Mode: Transmitting*

Test mode	Channel	Frequency	Conducted Output Power	Limit	Result
		(MHz)	(dBm)	(dBm)	
802.11b mode	Low	2412 MHz	6.54	30	PASS
	Middle	2437 MHz	6.12	30	PASS
	High	2462 MHz	5.81	30	PASS
802.11g mode	Low	2412 MHz	8.21	30	PASS
	Middle	2437 MHz	8.04	30	PASS
	High	2462 MHz	7.93	30	PASS
802.11n20 mode	Low	2412 MHz	8.25	30	PASS
	Middle	2437 MHz	7.96	30	PASS
	High	2462 MHz	7.71	30	PASS

Please refer to the following plots

### 802.11b OBW, Low Channel

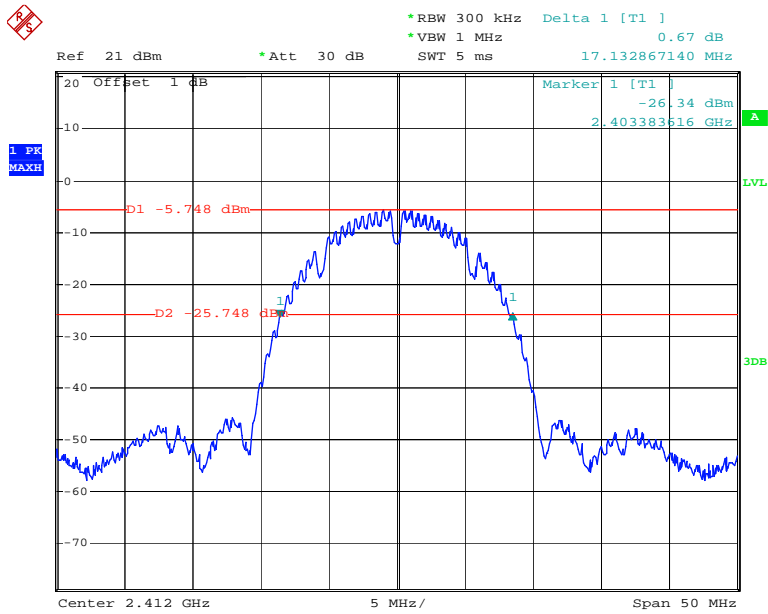

Date: 9.NOV.2013 00:42:16

### 802.11b RF Output Power, Low Channel

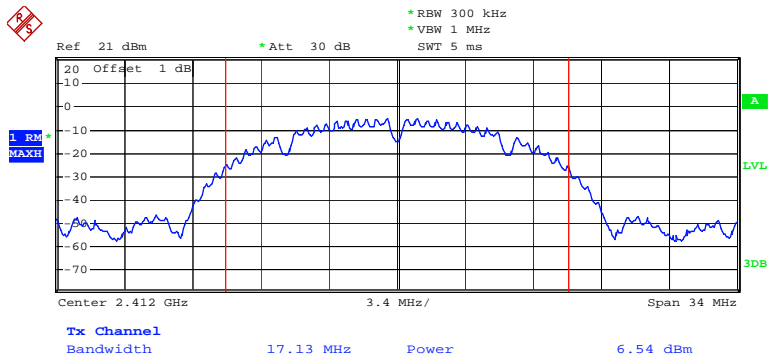

Date: 9.NOV.2013 00:43:09

### 802.11b OBW, Middle Channel

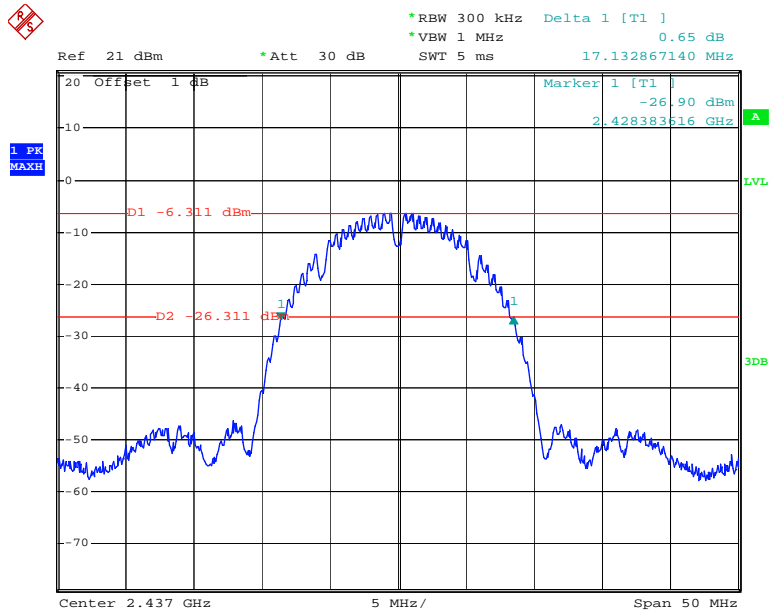

Date: 9.NOV.2013 00:44:36

### 802.11b RF Output Power, Middle Channel

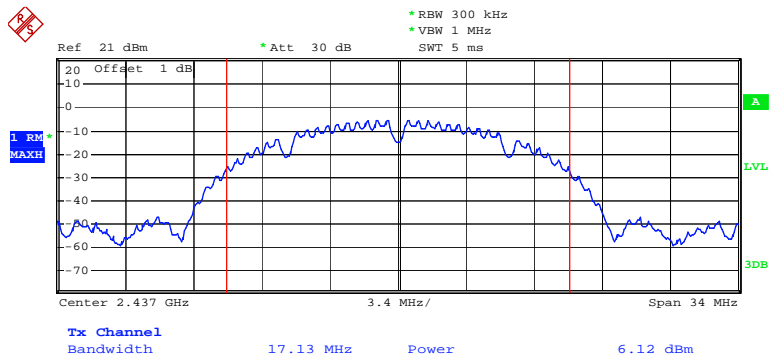

Date: 9.NOV.2013 00:45:03

### 802.11b OBW, High Channel

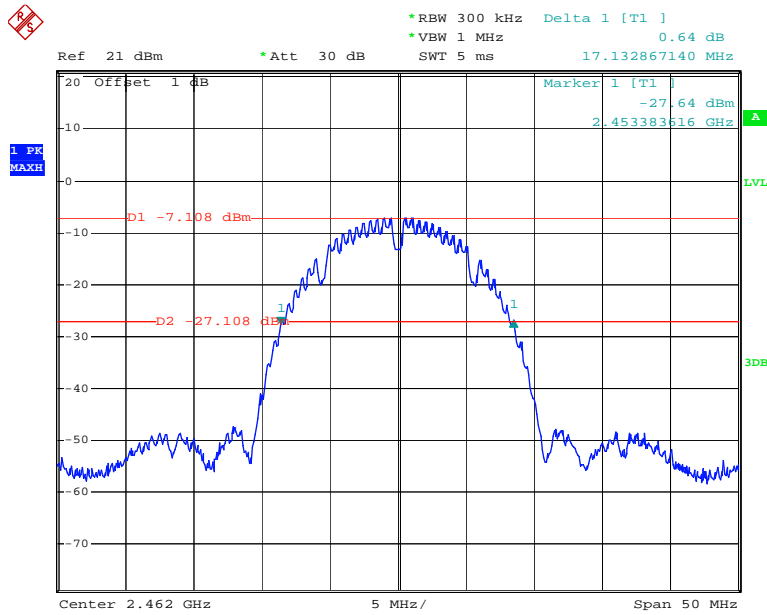

Date: 9.NOV.2013 00:47:04

### 802.11b RF Output Power, High Channel

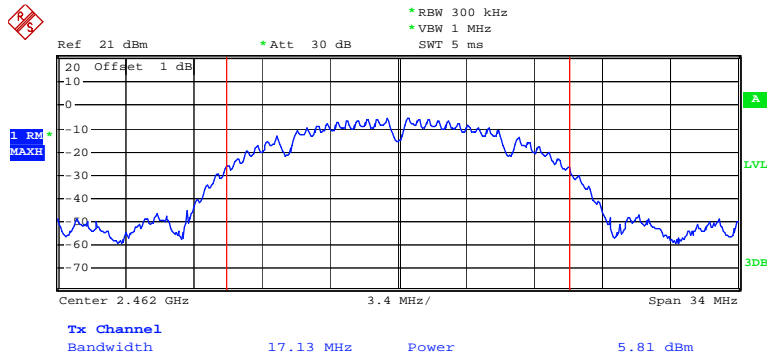

Date: 9.NOV.2013 00:47:33

### 802.11g OBW, Low Channel

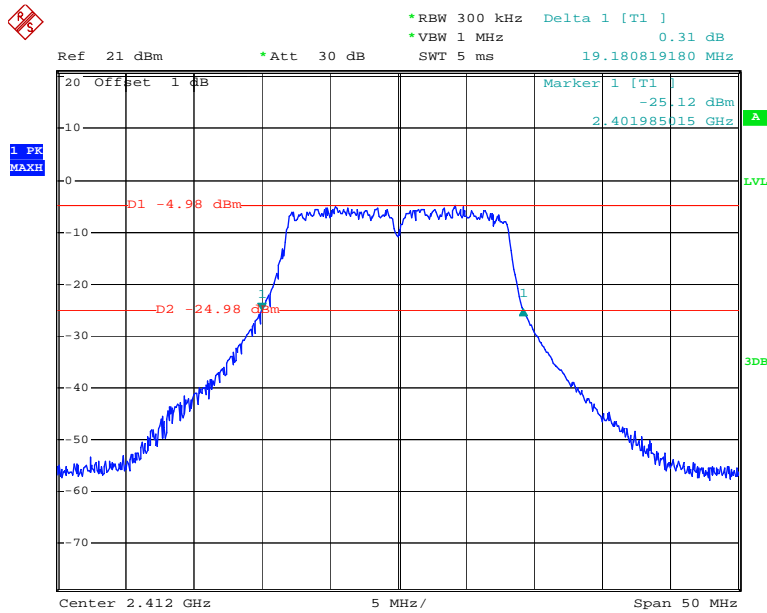

Date: 9.NOV.2013 00:49:38

### 802.11g RF Output Power, Low Channel

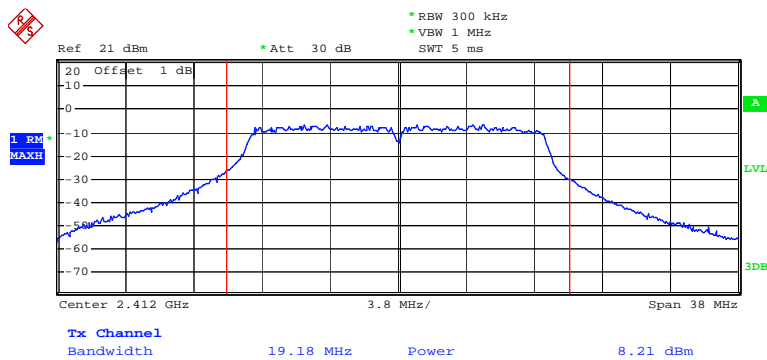

Date: 9.NOV.2013 00:50:23

### 802.11g OBW, Middle Channel

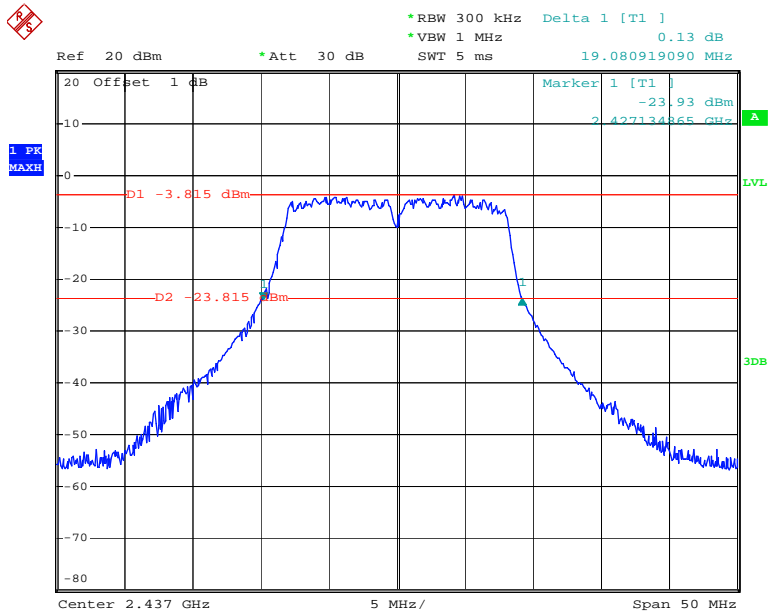

Date: 9.NOV.2013 00:52:06

### 802.11g RF Output Power, Middle Channel

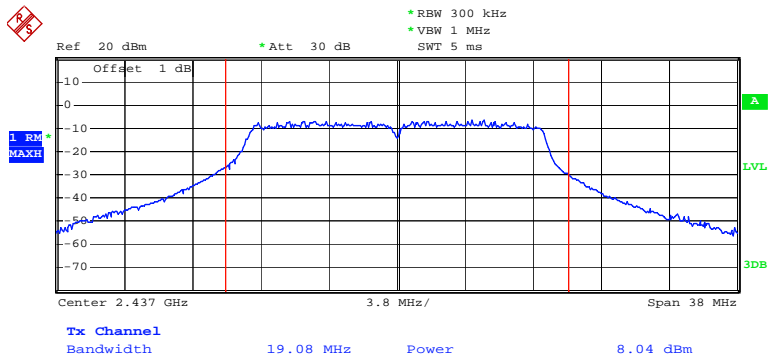

Date: 9.NOV.2013 00:52:44



### 802.11g RF OBW, High Channel

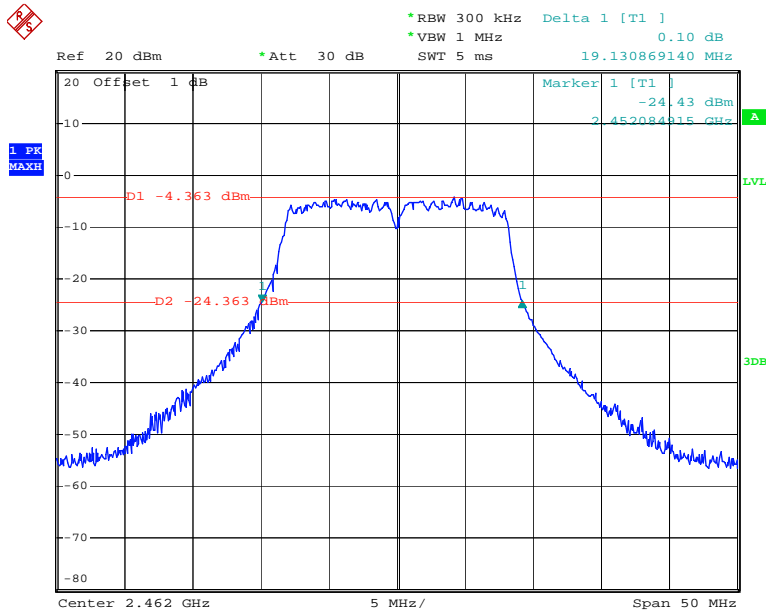

Date: 9.NOV.2013 00:53:46

### 802.11g RF Output Power, High Channel

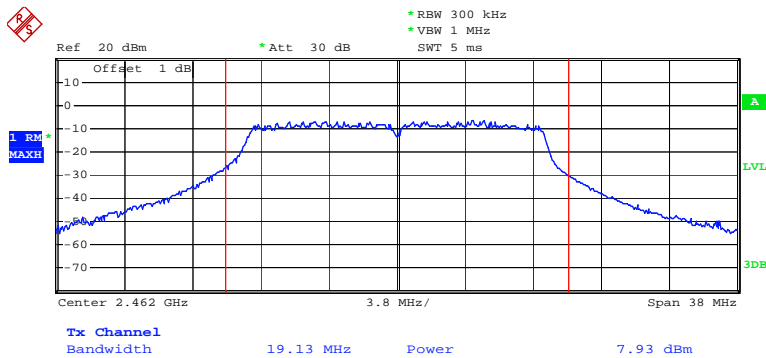

Date: 9.NOV.2013 00:54:46

### 802.11n20 OBW, Low Channel

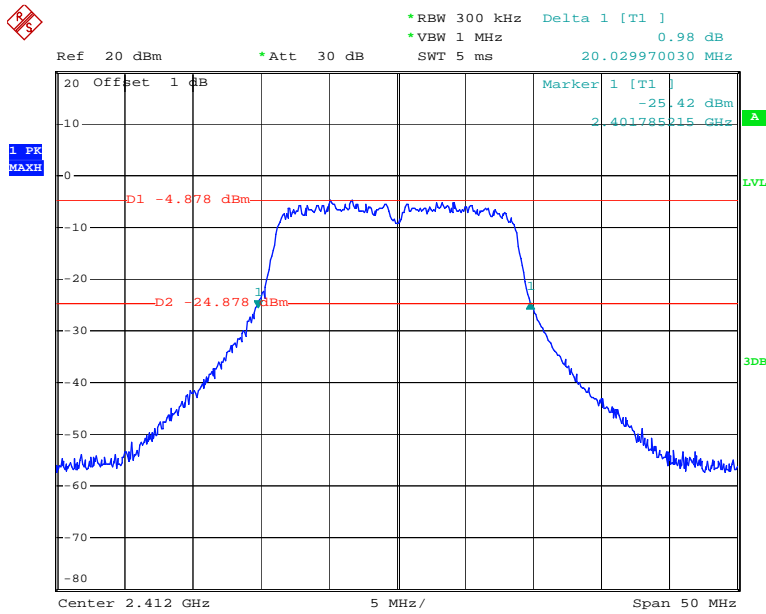

Date: 9.NOV.2013 00:55:57

### 802.11n20 RF Output Power, Low Channel

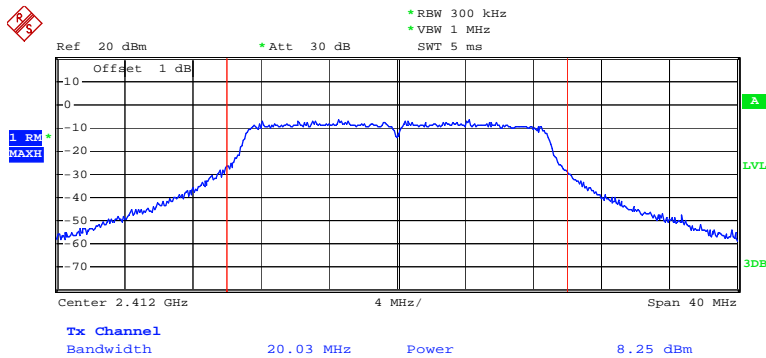

Date: 9.NOV.2013 00:56:19

### 802.11n20 OBW, Middle Channel

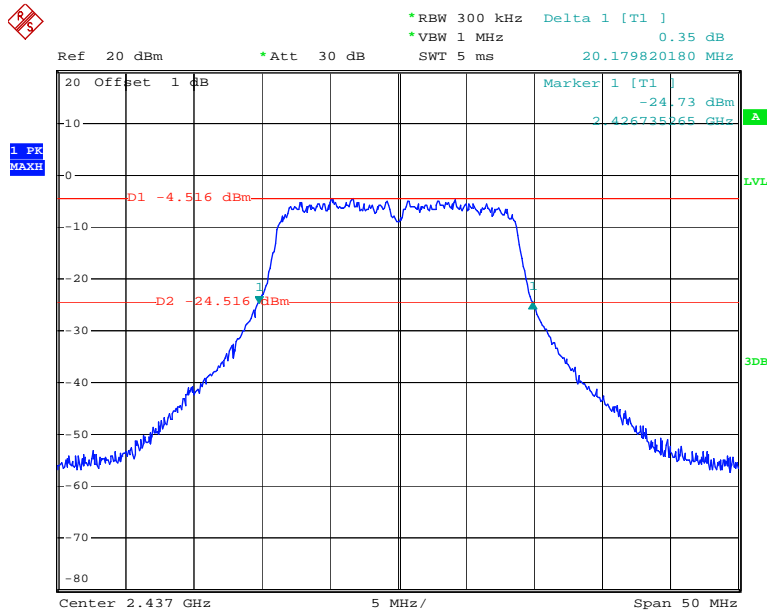

Date: 9.NOV.2013 00:57:34

### 802.11n20 RF Output Power, Middle Channel

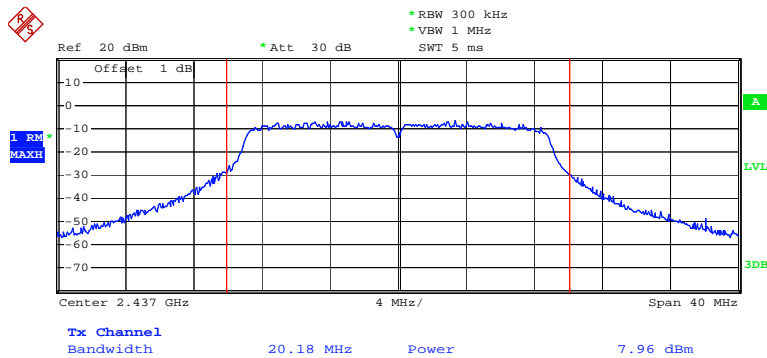

Date: 9.NOV.2013 00:58:09

### 802.11n20 OBW, High Channel

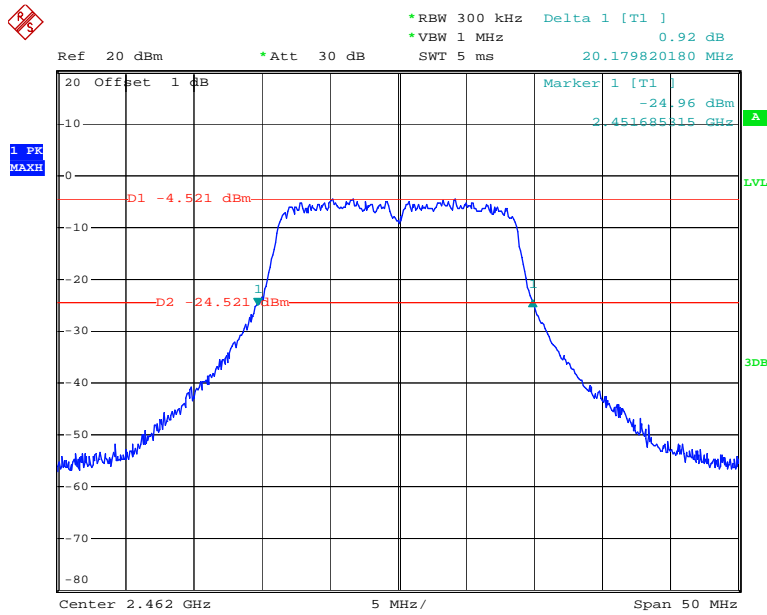

Date: 9.NOV.2013 01:00:05

### 802.11n20 RF Output Power, High Channel

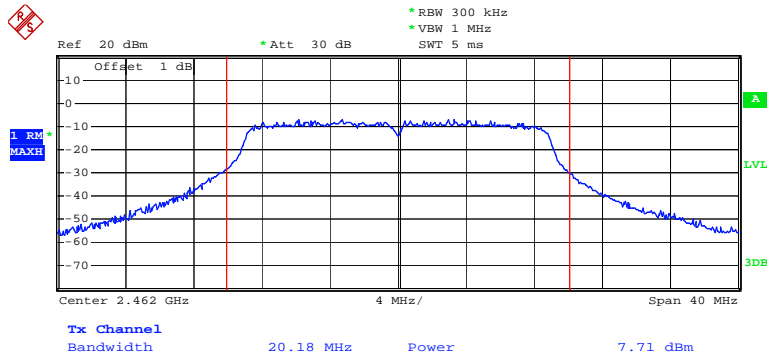

Date: 9.NOV.2013 01:00:40

## **FCC §15.247(d) – 100 kHz BANDWIDTH OF FREQUENCY BAND EDGE**

### **Applicable Standard**

In any 100 kHz bandwidth outside the frequency band in which the spread spectrum or digitally modulated intentional radiator is operating, the radio frequency power that is produced by the intentional radiator shall be at least 20 dB below that in the 100 kHz bandwidth within the band that contains the highest level of the desired power, based on either an RF conducted or a radiated measurement, provided the transmitter demonstrates compliance with the peak conducted power limits. If the transmitter complies with the conducted power limits based on the use of RMS averaging over a time interval, as permitted under paragraph (b)(3) of this section, the attenuation required under this paragraph shall be 30 dB instead of 20 dB. Attenuation below the general limits specified in §15.209(a) is not required. In addition, radiated emissions which fall in the restricted bands, as defined in §15.205(a), must also comply with the radiated emission limits specified in §15.209(a) (see §15.205(c)).

### **Test Procedure**

1. Check the calibration of the measuring instrument using either an internal calibrator or a known signal from an external generator.
2. Position the EUT without connection to measurement instrument. Turn on the EUT and connect its antenna terminal to measurement instrument via a low loss cable. Then set it to any one measured frequency within its operating range, and make sure the instrument is operated in its linear range.
3. Set RBW to 100 kHz and VBW of spectrum analyzer to 300 kHz with a convenient frequency span including 100 kHz bandwidth from band edge.
4. Measure the highest amplitude appearing on spectral display and set it as a reference level. Plot the graph with marking the highest point and edge frequency.
5. Repeat above procedures until all measured frequencies were complete.

### **Test Equipment List and Details**

<b>Manufacturer</b>	<b>Description</b>	<b>Model</b>	<b>Serial Number</b>	<b>Calibration Date</b>	<b>Calibration Due Date</b>
R&S	Spectrum analyzer	FSP 38	100478	2013-6-16	2014-6-15

\* **Statement of Traceability:** Bay Area Compliance Laboratories Corp. (Dongguan) attests that all calibrations have been performed in accordance to NVLAP requirements, traceable to National Primary Standards and International System of Units (SI).

### **Test Data**

#### **Environmental Conditions**

<b>Temperature:</b>	26.2 °C
<b>Relative Humidity:</b>	59 %
<b>ATM Pressure:</b>	100.3 kPa

*The testing was performed by Leon Chen on 2013-09-17.*

#### **Test Result: Compliance**

Please refer to following table and plots.

**802.11b: Band Edge, Left Side**

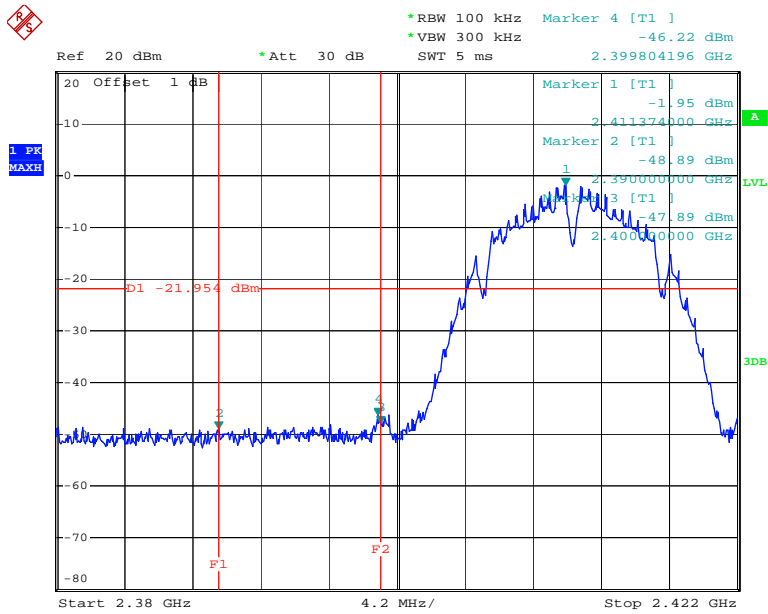

Date: 17.SEP.2013 16:58:23

**802.11b: Band Edge, Right Side**

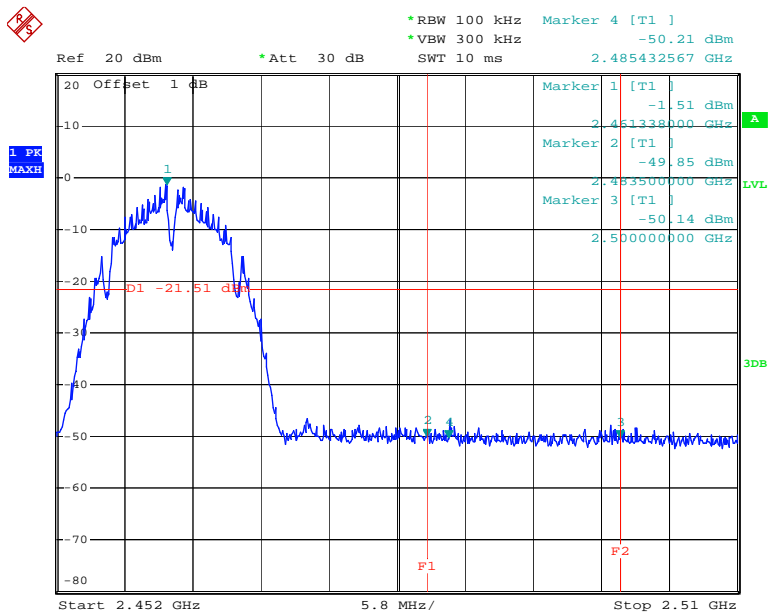

Date: 17.SEP.2013 17:34:57

### 802.11g: Band Edge, Left Side

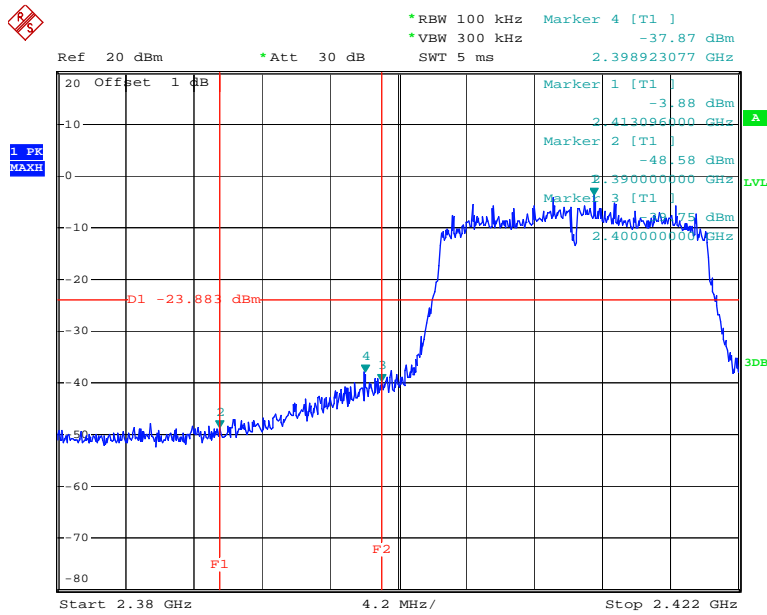

Date: 17.SEP.2013 17:02:22

### 802.11g: Band Edge, Right Side

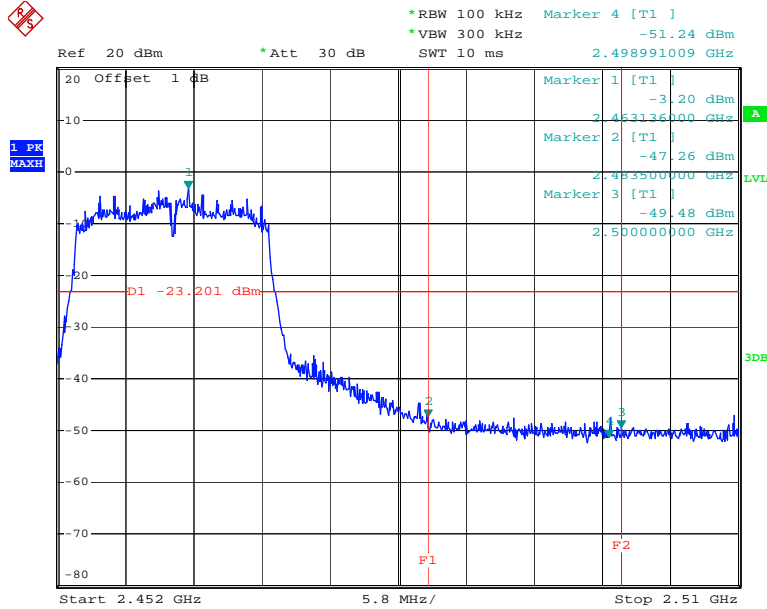

Date: 17.SEP.2013 17:05:20

### 802.11n20 Band Edge, Left Side

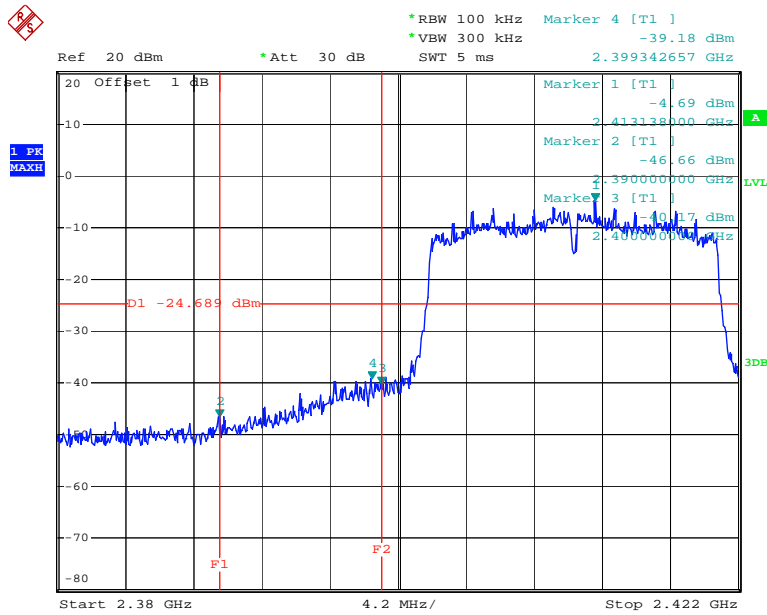

Date: 17.SEP.2013 17:37:20

### 802.11n20 Band Edge, Right Side

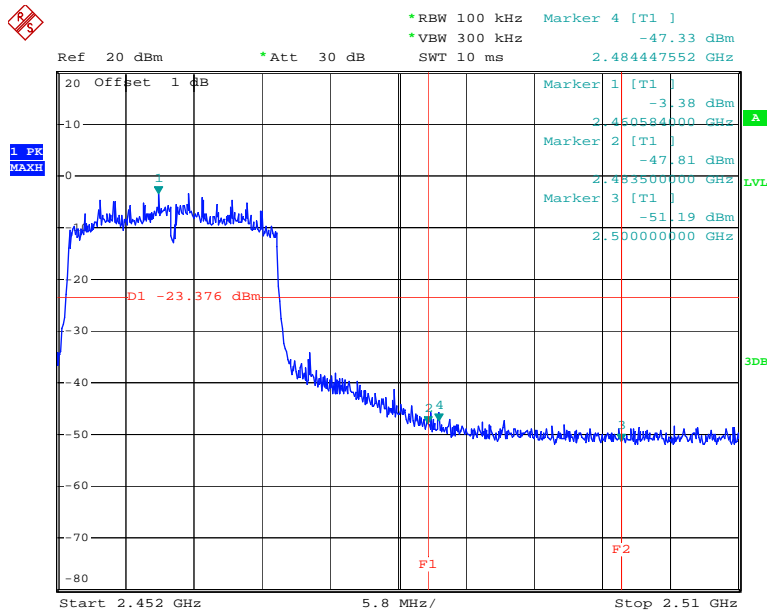

Date: 17.SEP.2013 17:10:52



## FCC §15.247(e) - POWER SPECTRAL DENSITY

### Applicable Standard

For digitally modulated systems, the power spectral density conducted from the intentional radiator to the antenna shall not be greater than 8 dBm in any 3 kHz band during any time interval of continuous transmission. This power spectral density shall be determined in accordance with the provisions of paragraph (b) of this section. The same method of determining the conducted output power shall be used to determine the power spectral density.

### Test Procedure

1. Check the calibration of the measuring instrument using either an internal calibrator or a known signal from an external generator.
2. Position the EUT was set without connection to measurement instrument. Turn on the EUT and connect its antenna terminal to measurement instrument via a low loss cable. Then set it to any one measured frequency within its operating range, and make sure the instrument is operated in its linear range.
3. According to KDB 558074 D01 DTS Meas Guidance v03r01, set the RBW = 3 kHz, VBW = 10 kHz, Set the span to 1.5 times the DTS channel bandwidth.
4. Use the peak marker function to determine the maximum power level in any 3 kHz band segment within the fundamental EBW.

### Test Equipment List and Details

Manufacturer	Description	Model	Serial Number	Calibration Date	Calibration Due Date
R&S	Spectrum analyzer	FSP 38	100478	2013-6-16	2014-6-15

\* **Statement of Traceability:** Bay Area Compliance Laboratories Corp. (Dongguan) attests that all calibrations have been performed in accordance to NVLAP requirements, traceable to National Primary Standards and International System of Units (SI).

### Test Data

#### Environmental Conditions

<b>Temperature:</b>	26.2 °C
<b>Relative Humidity:</b>	59 %
<b>ATM Pressure:</b>	100.3 kPa

*The testing was performed by Leon Chen on 2013-09-17.*

Test Mode: Transmitting

Test Result: Pass

Test mode	Channel	PSD	Limit	Result
		(dBm/3kHz)	(dBm/3kHz)	
802.11b mode	Low	-17.05	8	PASS
	Middle	-17.14	8	PASS
	High	-16.66	8	PASS
802.11g mode	Low	-18.23	8	PASS
	Middle	-17.20	8	PASS
	High	-16.93	8	PASS
802.11n20 mode	Low	-18.11	8	PASS
	Middle	-17.66	8	PASS
	High	-18.05	8	PASS

Please refer to the following plots

Power Spectral Density, 802.11b Low Channel

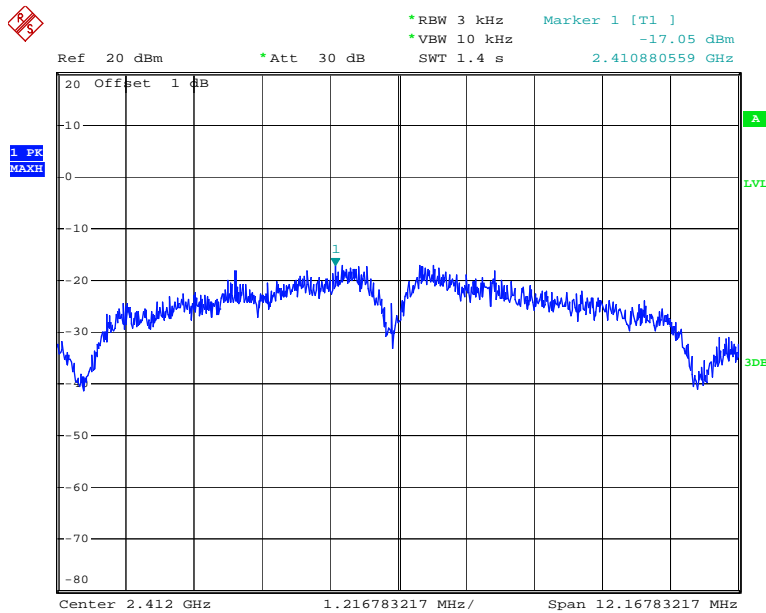

Date: 17.SEP.2013 16:57:58

### Power Spectral Density, 802.11b Middle Channel

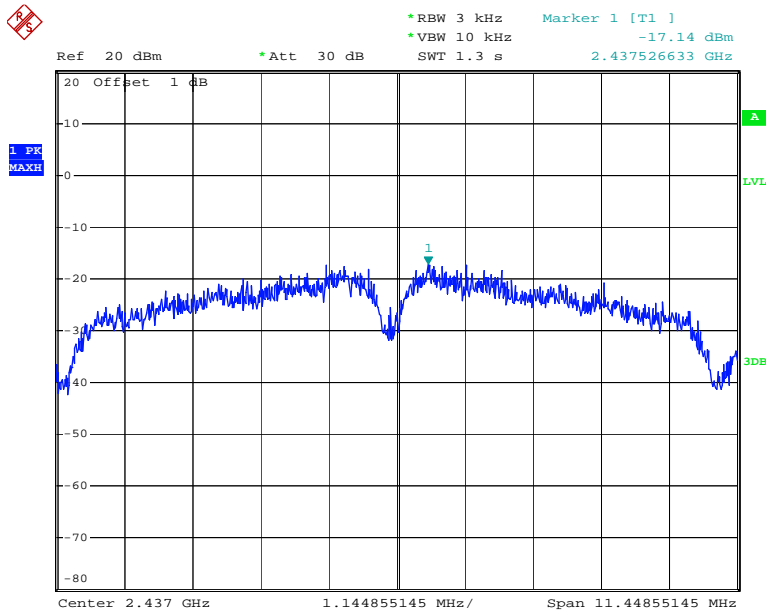

Date: 17.SEP.2013 17:29:21

### Power Spectral Density, 802.11b High Channel

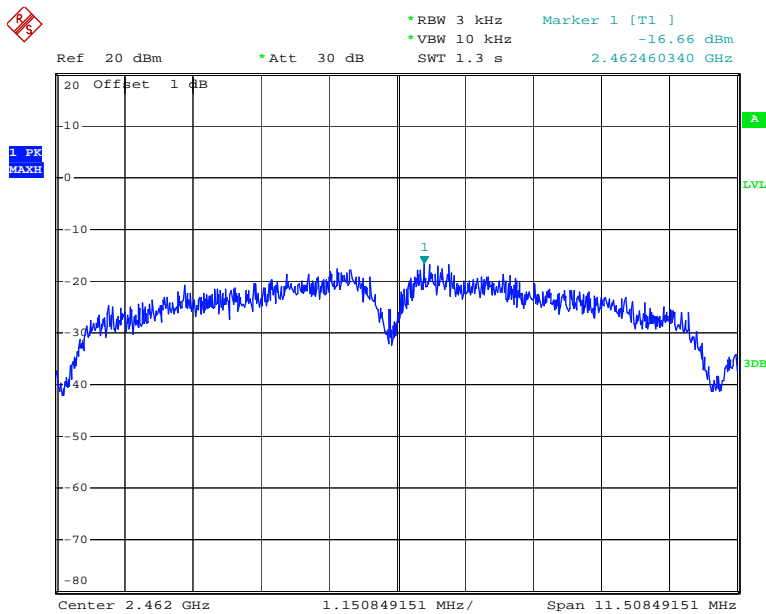

Date: 17.SEP.2013 17:34:33

### Power Spectral Density, 802.11g Low Channel

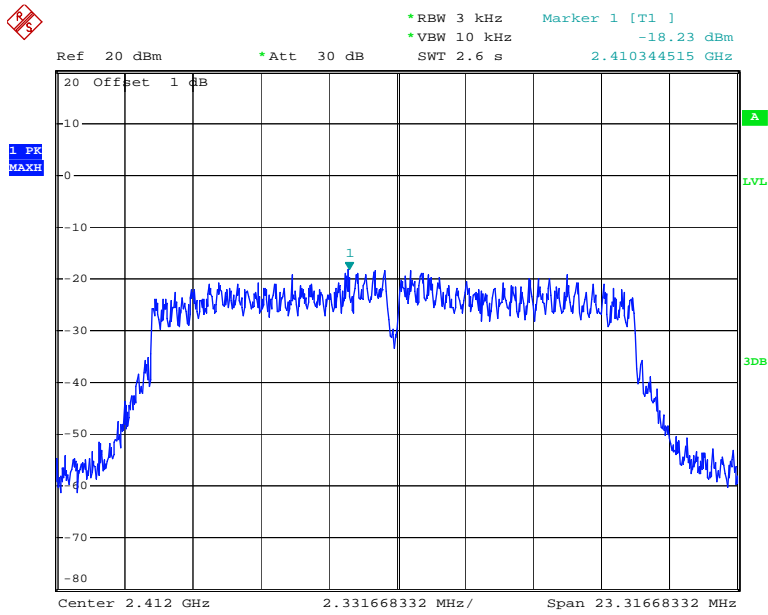

Date: 17.SEP.2013 17:01:57

### Power Spectral Density, 802.11g Middle Channel

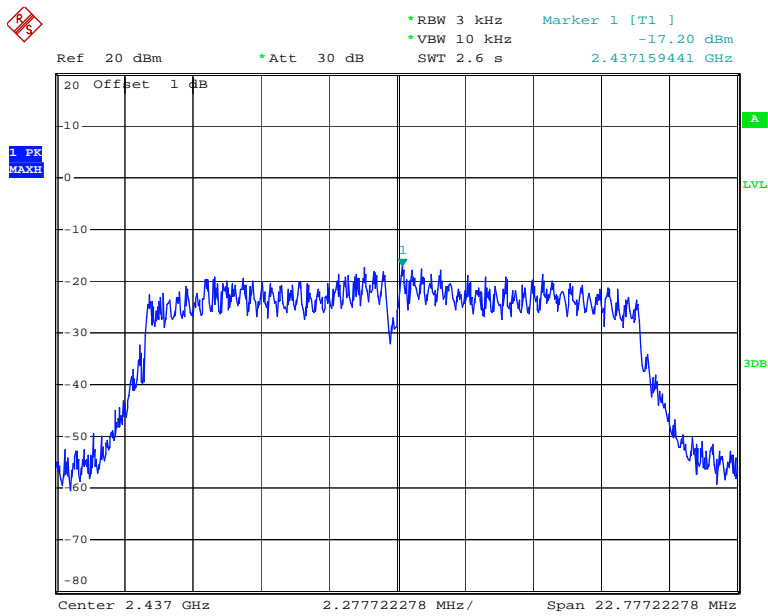

Date: 17.SEP.2013 17:03:32

### Power Spectral Density, 802.11g High Channel

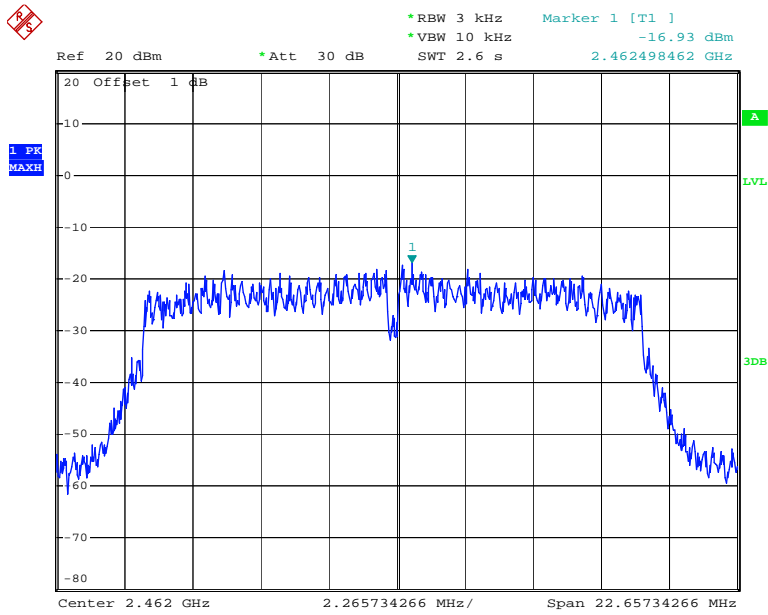

Date: 17.SEP.2013 17:04:56

### Power Spectral Density, 802.11n20 Low Channel

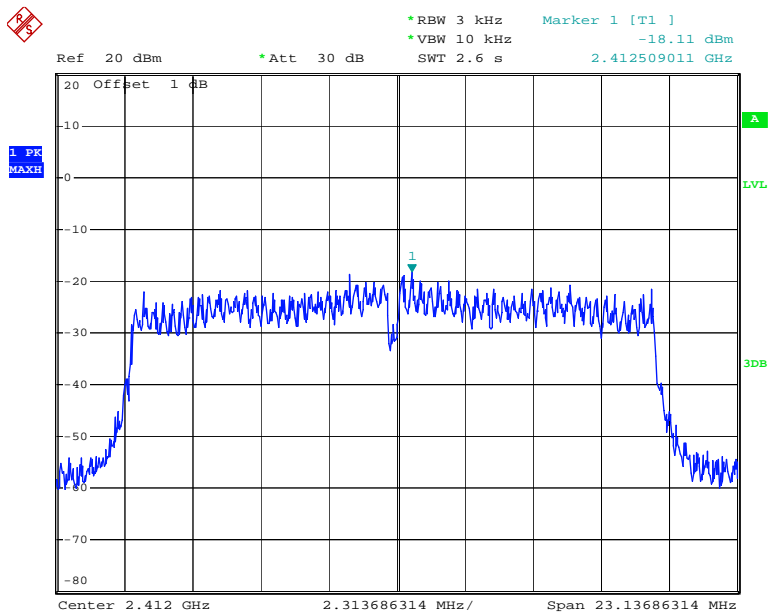

Date: 17.SEP.2013 17:36:55

### Power Spectral Density, 802.11n20 Middle Channel

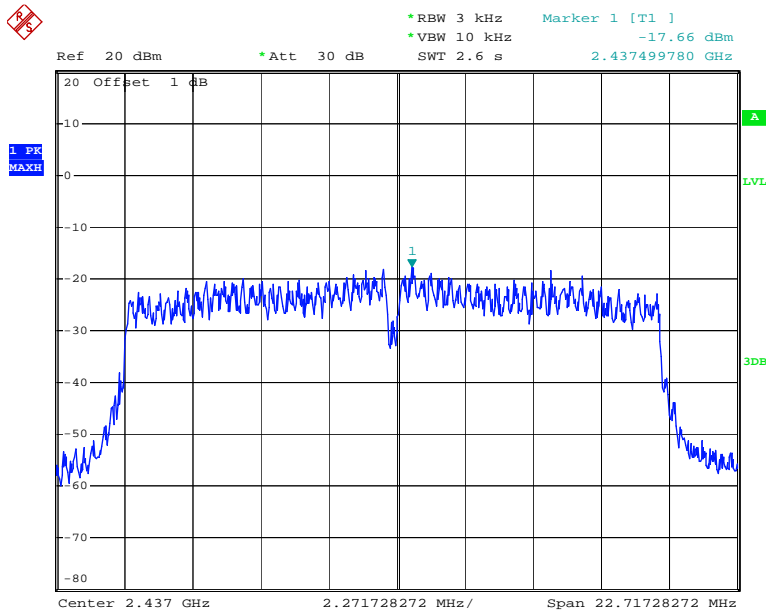

Date: 17.SEP.2013 17:08:48

### Power Spectral Density, 802.11n20 High Channel

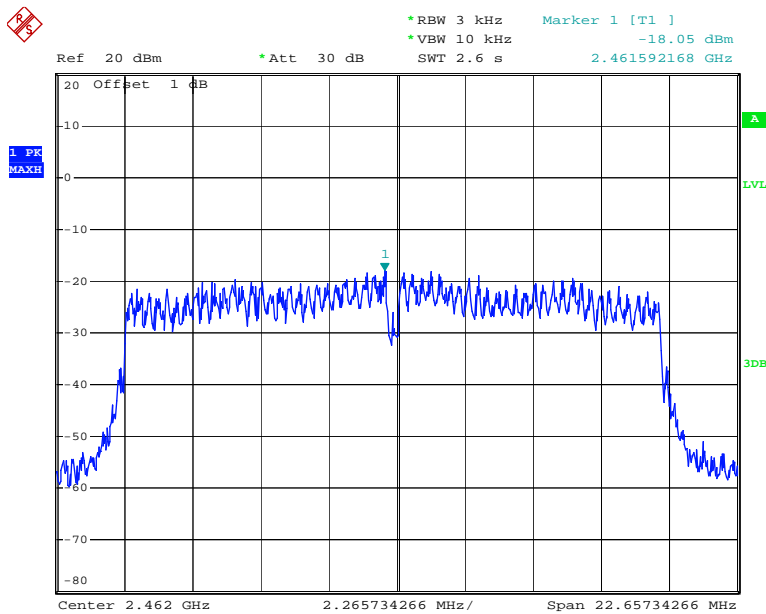

Date: 17.SEP.2013 17:10:28

## DECLARATION OF SIMILARITY



Action Electronics Co Ltd.  
ADD: No. 198, Chung Yuan Road Chung, Chung Li, Taiwan  
Tel: 88634515494 Fax: 88634629341

## DECLARATION OF SIMILARITY

Date: 2013-10-8

To:  
Bay Area Compliance Laboratories Corp. (Dongguan)  
No.69 Pulong Village Puxinhu Industry Zone Tangxia,  
Dongguan, China  
<http://www.baclcorp.com>

Dear Sir or Madam:

We, Action Electronics Co Ltd., hereby declare that product: 8" Tablet PC , have four models: MID30801, T852 MID , MID30802 and T852 SBK . The differences between them are the model name and with or without docking part, model MID30802 and T852 SBK with docking part, model MID30801 and T852 MID without docking part. Compared with MID30801 and T852 MID, MID30802 and T852 SBK have worse electromagnetic compatibility performance.

Please contact me should there be need for any additional clarification or information.

Best Regards,

Tanliang Lee  
RD Manager



\*\*\*\*\* END OF REPORT \*\*\*\*\*