

## Exhibit 11 Listing of Required Measurements

### Section 2.1033(c)(14)

The data required by Section 2.1046 through 2.1057, inclusive, measured in accordance with the procedures set out in Section 2.1041.

Each required measurement and its corresponding exhibit number are listed below along with the overall results:

<u>Exhibit #</u>	<u>Applicable FCC Rule</u>	<u>FCC Requirement Title</u>	<u>Test Result</u>
Exhibit 12	Section 2.1046	Measurement of Radio Frequency Power Output	Compliant
Exhibit 13	Section 2.1047	Measurement of Modulation Characteristics	Compliant
Exhibit 14	Section 2.1049	Measurement of Occupied Bandwidth	Compliant
Exhibit 15	Section 2.1051	Measurement of Spurious Emissions at Antenna	Compliant
Exhibit 16	Section 2.1053	Field Strength of Spurious Radiation (No new data submitted –original filing data reproduced)	Compliant
Exhibit 17	Section 2.1055	Measurement of Frequency Stability (No new data submitted –Refer to original filing)	Compliant
Exhibit 18	Section 2.1057(a)(1)(b)(c)	Frequency spectrum to be investigated.	

### Section 2.1057(a)(1)(b)(c) Frequency spectrum to be investigated.

The Frequency range of measurement is required to be from the lowest clock frequency to above the tenth harmonic of the transmit frequency.

#### Response:

The lowest RF clock frequency in the **PCS P4PAM EDPD Transceiver System** is the 10 MHz Precision Crystal reference oscillator. Conducted and Radiated spurious measurements were performed over the range of 10 MHz to 20 GHz which is above the tenth harmonic of the transmit frequency range. Measurements for conducted and radiated spurious emissions were continuous

The following pages include the data required for the Product Certification authorization of the **PCS P4PAM EDPD Transceiver System** / FCC ID: AS5ONEBTS-25, measured in accordance with the procedures set out in Section 2.1041 of the Rules.

## Exhibit 12 MEASUREMENT OF RADIO FREQUENCY POWER OUTPUT

### SECTION 2.1046 Measurements required: RF power output.

The test arrangements used to measure the radio frequency power output of the *PCS P4PAM EDPD Transceiver System* / FCC ID: AS5ONEBTS-25 is on the following page. Measurements were made respectively at each frequency where Occupied Bandwidth measurements were performed. This FCC Product Certification FCC Product Certification Filing is for use of the *PCS P4PAM EDPD Transceiver System* with CDMA modulation for one and two amplifier configurations at 80 W total power per amplifier. Demonstration of compliance with the operation using the two carrier per single amplifier and four carriers per dual amplifier configurations was demonstrated in all PCS Blocks (A, D, B, E, F, C and G). The initial Filing data for Block B was repeated so a complete data package was together in this report. No retuning or change in hardware is required for operation in any PCS Block. However, operation requires that the Antenna Connection (J4) power level be calibrated for each specific channel of use. The test was performed using the configuration in Figure 12a, which allowed for continuous measurement of output power for each channel investigated during Occupied Bandwidth and Transmitter Conducted spurious measurement. These included the upper and lower Block edges and at the center channel for each Block.

In the **PCS P4PAM EDPD Transceiver System / FCC ID: AS5ONEBTS-25** system has a maximum power output of 80 Watts total at the antenna terminals (49.03 dBm/c +2/-4 dB for a single amplifier). It also has a minimum power output at the antenna terminals of 0.080 Watts/c (19.03 dBm +2 / -4 dB), across the PCS downlink Band (1930.00-1995.00 MHz). The base station test model channel parameters signal applied to the **PCS P4PAM EDPD Transceiver System** is defined in Table 12.1. The power was reset to the specified 80 W per amplifier distributed evenly for the number of carriers at each measurement frequency. This was performed to verify the spectral performance at that power level at each specific frequency of interest. The attenuation range was also verified. The specific Frequencies and channels and set power level was documented on each "Occupied Bandwidth" sheet.

The applied signal, from a **PCS P4PAM EDPD Transceiver System**, met the recommended characteristics per "**Table 6.5.2-1 Base Station Test Model, Nominal**" from **3GPP2 C.S0010-C v2.0, 24 February 2006**, Recommended Minimum Performance Standards for cdma2000 Spread Spectrum Base Stations, as defined below in table 12.1.

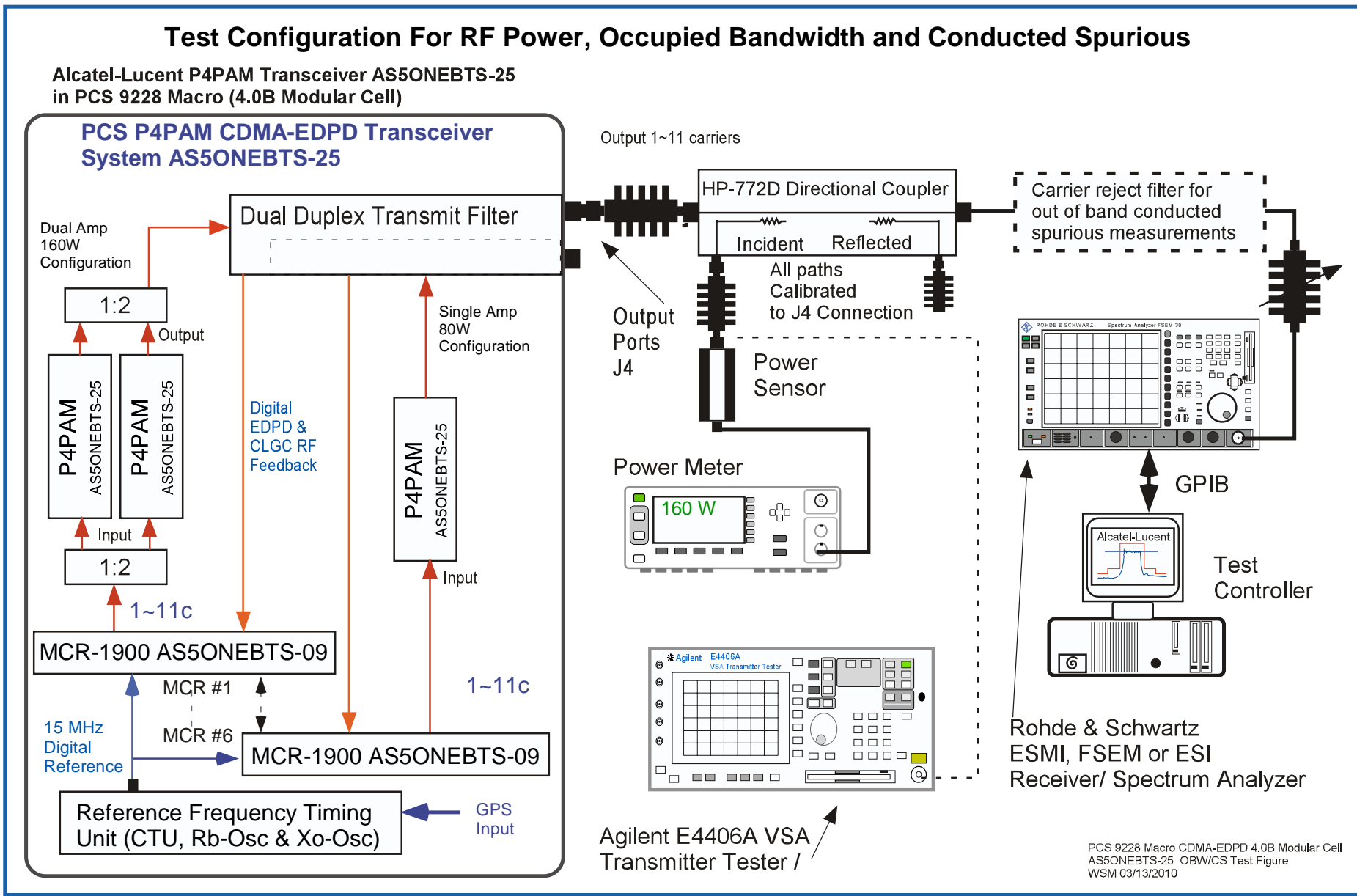
Type	Number of Channels	Fraction of Power (Linear)	Fraction of Power (dB)	Comments
Forward Pilot	1	0.2000	-7.0	Code channel $W_0^{64}$
Sync	1	0.0471	-13.3	Code channel $W_{32}^{64}$ ; always 1/8 rate
Paging	1	0.1882	-7.3	Code channel $W_1^{64}$ ; full rate only
Traffic	M = 37	$0.5647/M$ = 0.015262	-2.48 - 10 log(M) = -18.1620	Variable Walsh assignments, full rate only

**TABLE 12.1 Base Station Test Model, Nominal for Main Path**

Type	Number of Channels	Fraction of Power (Linear)	Fraction of Power (dB)	Comments
Transmit Diversity Pilot	1	0.2000	-7.0	Code channel $W_{16}^{128}$
Traffic	M = 37	$0.5647/M$ = 0.015262	-2.48 - 10 log(M) = -18.1620	Variable Walsh code channel assignments, full rate only

**TABLE 12.2 Base Station Test Model, Nominal for Transmit Diversity Path**

Exhibit 12 RF Power Test Configuration



**Exhibit 12 continued**

**Equipment used for RF Power, Modulation, Occupied bandwidth and Conducted Spurious Measurements**

<u>Equipment</u>	<u>Description</u>	<u>Number</u>	<u>Cal Date</u>
Power Meter:	Agilent N1912A P Series Power Meter	82-11299434	19-Oct-09
Power Head	Agilent N1921A 0.05-18 GHz Wideband Power Sensor	82-11295743	19-Oct-09
EMI Test Receiver	Rohde & Schwarz ESIB-40	100101 / FAT 1503607	20-Oct-09
Computer Controller:	EG Technology, Intel Pentium PC w/ WIN XP OS	POR-2, 6 & 7	n/a
EMC Test Software	TILE, Quantum Change,	Version 3.4.K.14	n/a
Printer:	HP Model 4500DN Printer	N/A	n/a
Low Pass Filters:	10 MHz-1.93 GHz, Custom manufactured	PCSLPF-11	18-Feb-10
High Pass Filters:	1.99-20 GHz, Custom manufactured	PCSHPF-11	23-Feb-10
GPS T&F Reference Rcvr	Symmetricon 58503B GPS Time and Frequency Reference Receiver	166852	NA
VSA Transmitter Tester	Agilent E4406A	166534	21-Oct-09
<b>RF Test coupler</b>	<b><u>Description</u></b> <b>The equipment below is maintained and calibrated together.</b>	<b><u>Number</u></b>	<b><u>Cal Date</u></b>
Directional Coupler:	HP 772D Dual Directional Coupler HP s/n 2039A00548/	Green 200W Mule	09-Jun-09
Attenuator, Variable	HP 8494B DC-18 GHz digital attenuator	FAC000WH013007ANJ0117	
Attenuator, Variable	HP 8495B DC-18 GHz digital attenuator	MY41110681	
Attenuator, Fixed	Weinschel Corp DC-18 GHz,	MY42140030	
Test Cables:	UFB197C-1-0240 & 0960-50U5GL	6791, s/n 002	
		s/n 007 & 003	

**Exhibit 12** *continued* **Measurements required: RF power output.**

PCS - Block	PCS -Channels		Number of carriers	Power per Carrier, W/c	Number of Amplifiers	Total Power Watts	Results RF Power Output
<b>Single amplifier 2 Carrier Configuration</b>							
A	25-50	250-275	2	40	1	80	Compliant
D	325-350	350-375	2	40	1	80	Compliant
B	425-450	650-675	2	40	1	80	Compliant
E	725-750	750-775	2	40	1	80	Compliant
F	825-850	850-875	2	40	1	80	Compliant
C	925-950	1150-1175	2	40	1	80	Compliant
G	1225-1250	1250-1275	2	40	1	80	Compliant
<b>Single amplifier 4 Carrier Configuration</b>							
A	25-100	200-275	4	20	1	80	Compliant
D	325-400		4	20	1	80	Compliant
B	425-500	600-675	4	20	1	80	Compliant
E	700-775		4	20	1	80	Compliant
F	825-900		4	20	1	80	Compliant
C	925-1000	1100-1175	4	20	1	80	Compliant
G	1200-1275		4	20	1	80	Compliant
<b>Two amplifier 4 Carrier Configuration</b>							
A	25-100	200-275	4	40	2	160	Compliant
AD	325-400		4	40	2	160	Compliant
B	425-500	600-675	4	40	2	160	Compliant
BE	700-775		4	40	2	160	Compliant
FC	825-900		4	40	2	160	Compliant
C	925-1000	1100-1175	4	40	2	160	Compliant
CG	1200-1275		4	40	2	160	Compliant
<b>Two amplifier 8 Carrier Configuration</b>							
A	25-100	200-275	8	20	2	160	Compliant
AD	325-400		8	20	2	160	Compliant
B	425-500	600-675	8	20	2	160	Compliant
BE	700-775		8	20	2	160	Compliant
FC	825-900		8	20	2	160	Compliant
C	925-1000	1100-1175	8	20	2	160	Compliant
CG	1200-1275		8	20	2	160	Compliant

**RESULTS:**

The **PCS P4PAM EDPD Transceiver System** / FCC ID: AS5ONEBTS-25 was configured in the test setup shown in Figure 12A. For the 1 and 2 amplifier configurations the *PCS P4PAM EDPD Transceiver System* / FCC ID: AS5ONEBTS-25 delivered a minimum of 80.0 Watts per amplifier of Total Power +2/-0 dB when measured at the J4 output connection. This data is recorded on the Occupied Bandwidth Data Sheets for “Left edge” and “Right Edge” of each frequency Block and summarized in the Table above.

Note: The **PCS P4PAM EDPD Transceiver System** / FCC ID: AS5ONEBTS-25 Enhanced Digital Pre-Distortion System allows for remote calibration and adjustment of its power level at each cell site during setup.

**Conclusion:**

This demonstrates that the **PCS P4PAM EDPD Transceiver System** / FCC ID: AS5ONEBTS-25, the subject of this application, complies with Sections 2.1053, 24.238 and 2.1046 of the Rules.

**Exhibit 13**

**SECTION 2.1047 MEASUREMENT OF MODULATION CHARACTERISTICS**

The modulation characteristics and accuracy of the output signal of the **PCS P4PAM EDPD Transceiver System / FCC ID: AS5ONEBTS-25** is solely a function of the Multi Carrier Radio 1900 (MCR-1900).

**13.1 - Modulation Description**

The modulation methods used in CDMA drastically differ from those used in a FM analog system. The methods used in evaluating the **PCS P4PAM EDPD Transceiver System / FCC ID: AS5ONEBTS-25** are described in the pertinent standards documents which include **TIA/EIA-97-C** “recommended Minimum performance Standards for Base Stations Supporting Dual-Mode Wideband Spread Spectrum Cellular Mobile Stations” and **3GPP2 C.S0010-C v2.0, 24 February 2006, Recommended Minimum Performance Standards for cdma2000 Spread Spectrum Base Stations**. The modulation quantify criteria are as follows:

**13.2 Modulation Requirements – Section 4.2 of TIA/EIA-97-C and 3GPP2 C.S0010-0**

Waveform quality is tested by measuring the waveform quality  $\rho$ , as defined in 6.4.2.1, and code domain power as defined in 6.4.2.2. The range of values for the transmit waveform quality is from 1.0 for a perfect CDMA waveform to 0.0 for a non-CDMA signal. As an example, a base station with a 0.5 dB degradation in its transmit waveform would have a quality,  $\rho$ , of  $10^{-(0.5/10)} = 0.89$ .

**13.3 Minimum Standard ...per Section 4.2.2.3 of 3GPP2 C.S0010-C v2.0**

The normalized cross correlation coefficient,  $\rho$ , shall be greater than 0.912 (excess power  $\leq 0.4$  dB).

**13.4 Results**

The **PCS P4PAM EDPD Transceiver System / FCC ID: AS5ONEBTS-25** was configured in the test setup shown in Figure 13A. The **PCS P4PAM EDPD Transceiver System** was configured with its pilot channel and the modulation quality measured with an Agilent -E4406A VSA Series Transmitter Analyzer. Measurements were performed at the PCS Channels shown in table 13.1.

PCS Band	Transmit Channel(s)	Measured Rho	Status
A	25	0.99854	Compliant
D	325	0.99854	Compliant
B	450	0.99855	Compliant
E	725	0.99855	Compliant
F	825	0.99854	Compliant
C	1100	0.99855	Compliant
G	1275	0.99854	Compliant

**TABLE 13.1 MCR-1900 Channels for Modulation Characteristics Measurement**

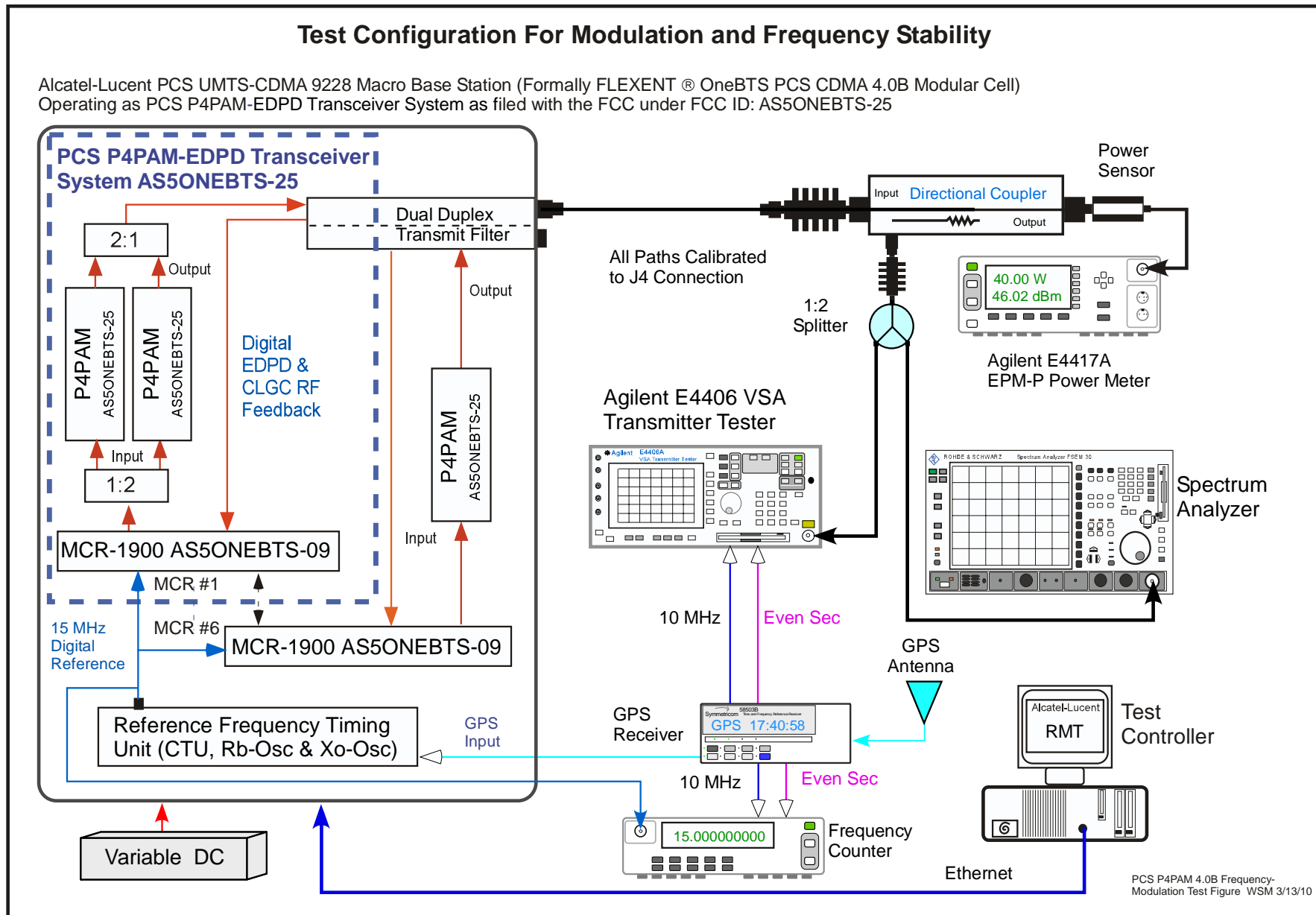
**Results Summary**

For each of the PCS channels tested, the **PCS P4PAM EDPD Transceiver System’s** modulation quality factor, Rho ( $\rho$ ), was measured to be  $\geq 0.99854$  which exceeds the required minimum value of 0.912. The **PCS P4PAM EDPD Transceiver System** transmit signal modulation parameters and Code Domain for PCS channel 25 is shown in Figures 13B and 13C below. The data for channel 25 is representative of the data recorded for the channels listed above and was taken utilizing the Agilent -E4406A VSA Series Transmitter Analyzer. It also verified that the frequency offset is less than (+/- 0.05 PPM) of the frequency assignment.

**Conclusion**

This demonstrates that the **PCS P4PAM EDPD Transceiver System / FCC ID: AS5ONEBTS-25**, the subject of this application, complies with Sections 2.1053, 24.238 and 2.1047 of the Rules.

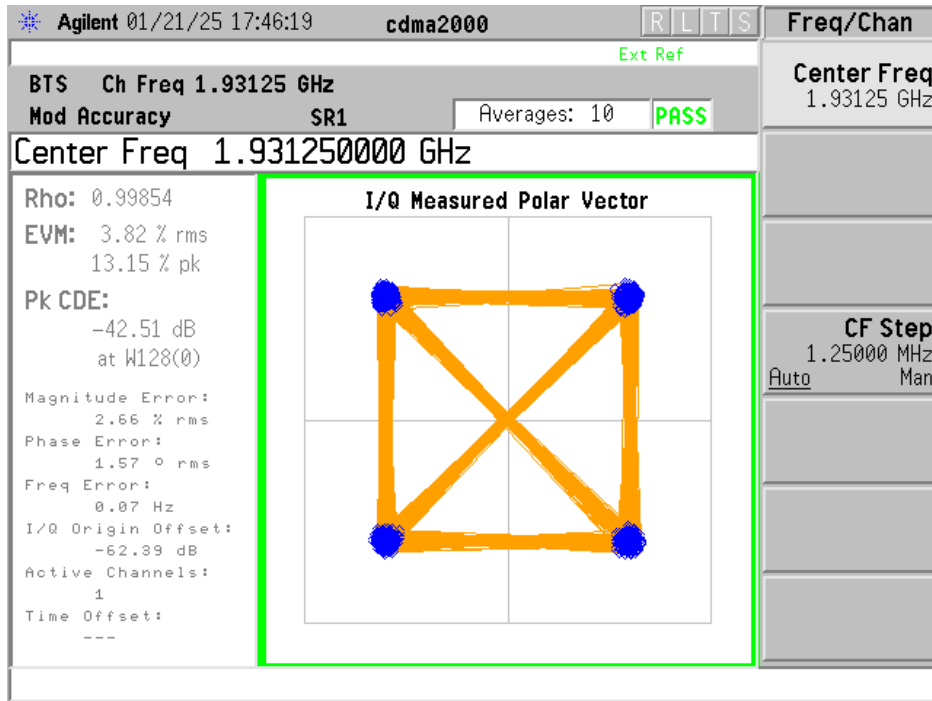
Figure 13A



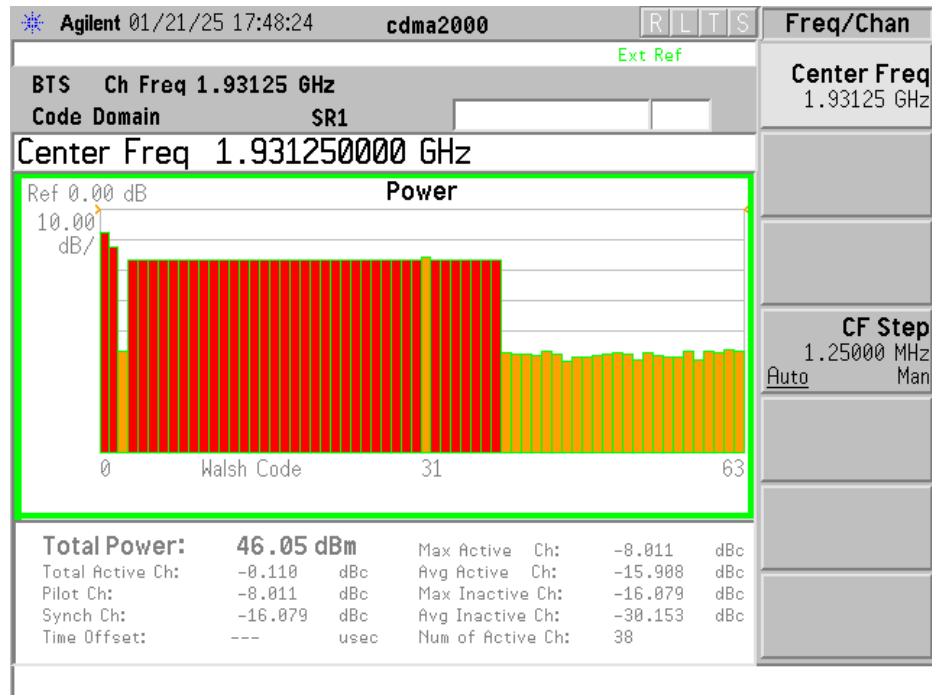




**Figure 13B**                      **Typical Rho 1c A Block, Channel 25 Tx Output**



**Figure 13B**                      **Typical Code Domain 1c A Block, Channel 25 Tx Output**



## Exhibit 14 MEASUREMENT OF OCCUPIED BANDWIDTH

### SECTION 2.1049 Measurement Of Occupied Bandwidth

Occupied bandwidth measurements of the **PCS P4PAM EDPD Transceiver System** / FCC ID: AS5ONEBTS-25 were performed for the channel edge configurations for all PCS Blocks. This documents the typical performance of the **PCS P4PAM EDPD Transceiver System** / while operating in a one and a two amplifier configuration. All power adjustments were performed via the MCR-1900 under software control. The measurement of the one and a two amplifier configuration at 80 W/amplifier cases are described below.

The occupied bandwidth of the **PCS P4PAM EDPD Transceiver System** / FCC ID: AS5ONEBTS-25 was measured using a Rohde & Schwarz Spectrum Analyzer, a PC based instrumentation controller using computer software and calibrated RF attenuation and coupled signal path. The RF power level was measured and adjusted via the test setup in Figure 14A. The set RF output from the transmitter was reduced by calibrated broadband attenuators to amplitudes usable by the spectrum analyzer and power meter. The attenuation factors are reflected in the displayed values of the charts. The typical occupied bandwidth measurement displays the signal adjusted to the -16.2 dBc level corresponding to the corrected RF power level for a 30 kHz resolution bandwidth (RBW). This set-point was performed as follows:

For each test the power calibration was individually verified at the transmitter antenna connection (J4) with a power meter by using the test setup depicted in Figure 14A. The power calibration was performed to calibrate the setting power meter measurement as a reference for both the measured 30 kHz Occupied Bandwidth signal at the -16.2 dBc line and a 3 MHz RBW measurement against the "Top of Mask" limit. The "Top of Mask" limit corresponds to a carrier signal at a specified power level which results in 80 W total power for the number of carriers being tested as measured with an RBW of  $\geq 1.25$  MHz. Since at the transmitter J4 output there may be multiple CDMA carriers, the measurement is made with an RBW setting of 3 MHz which is greater than the individual 1.25 MHz signal bandwidth. These power calibration measurements were performed along with each Occupied Bandwidth measurement. The signals measured at RBW's of 3 MHz and 30 kHz were corrected for path loss and were plotted against the mask limit. As part of the calibration between the power meter measurement and the test analyzer, software was used to place the 3 MHz RBW signal either at the "Top of Mask" for single carriers or at the carrier power calibration line for multi-carrier signals. The carrier as measured with 3 MHz and 30 kHz RBW were corrected with the same attenuation factors. The two measurements are co-plotted on the same graph. A typical single carrier example is shown in Figure 14B which depicts a single carrier (825 F Block) inside the mask for F Block.

The test procedure above, calibrates the carrier power to the "Top of Mask" and accurately places the 30 kHz RBW measured carrier at the -16.2 dBc reference line. All of the plots are presented with a sufficiently wide frequency span for the specific signals or block of interest. This allows for ease of comparison of the multi-carrier performance. This data was electronically recorded using the computer software and electronically placed in the Occupied Bandwidth Data Sheets. These sheets contain data for "Left Edge of Block", and "Right Edge of Block" for each PCS frequency Block of interest.

### Block Organization and Tests Performed

The **PCS P4PAM EDPD Transceiver System** operates as part of the 9228 Base Station macro (formally FLEXENT PCS Modular Cell 4.0B) product line. The **PCS P4PAM EDPD Transceiver System** allows the use of transmit filters with bandwidths from 5 MHz to as wide as 65 MHz. The use of EDPD provides the spurious control which allows the use of wide bandwidth filters such as a 60 MHz 1930-1990 MHz for the classic PCS Band, a shifted 60MHz A4G for blocks A4 through G or a 65 MHz Full PCS Band filters. These wideband filters provide for the least spurious reduction at "edge of block" and "edge of band" and thus represent the most difficult compliance configuration. The filters do not provide for any spurious reduction at the internal block edges inside the band. The testing of the product documented herein was performed with a 60 MHz and shifted 60 MHz PCS band filters. These test configurations are the most difficult for compliance demonstration.

**Exhibit 14** *continued*

The demonstration of compliance for the one and two amplifier 80W/amp configurations of the **PCS P4PAM EDPD Transceiver System** were performed for operation in all PCS Blocks (A through G). The presented data for this FCC Product Certification Filing demonstrates the one and two amplifier 80W/amp configurations compliance.

In order to adequately evaluate performance the worst case modulation factors of 2G Voice ( vs. 3G1X or 3G1X-EV-DO) were used from the governing documents. Thus, the applied signal, from a **PCS P4PAM EDPD Transceiver System**, met the recommended characteristics per "**Table 6.5.2-1 Base Station Test Model, Nominal**" from **3GPP2 C.S0010-C v2.0, 24 February 2006**, Recommended Minimum Performance Standards for cdma2000 Spread Spectrum Base Stations, as defined below in table 14.1.

Type	Number of Channels	Fraction of Power (Linear)	Fraction of Power (dB)	Comments
Forward Pilot	1	0.2000	-7.0	Code channel $W_0^{64}$
Sync	1	0.0471	-13.3	Code channel $W_{32}^{64}$ ; always 1/8 rate
Paging	1	0.1882	-7.3	Code channel $W_1^{64}$ ; full rate only
Traffic	M = 37	$0.5647/M$ = 0.015262	-2.48 - 10 log(M) = -18.1620	Variable Walsh assignments, full rate only

**TABLE 14.1 Base Station Test Model, Nominal for Main Path**

Type	Number of Channels	Fraction of Power (Linear)	Fraction of Power (dB)	Comments
Transmit Diversity Pilot	1	0.2000	-7.0	Code channel $W_{16}^{128}$
Traffic	M = 37	$0.5647/M$ = 0.015262	-2.48 - 10 log(M) = -18.1620	Variable Walsh code channel assignments, full rate only

**TABLE 14.2 Base Station Test Model, Nominal for Transmit Diversity Path**

The FCC limits contained in **47CFR 24.238 1-Oct-2007** were followed along with the minimum standard presented in **3GPP2 C.S0010-C v2.0, 24 February 2006**. Where combinational measurements of 3G1x-EV-DO are made along with the 2 GV configuration above the applied signal were based upon the 3GPP2 TSG-C.S0032-1 titled "Recommended Minimum Performance Standards for CDMA2000 High Rate Packet Data Access Network ". Section 3.1.2.4 Limitations on Emissions. This standard covers the emissions situation except that we use the maximum 25 MAC full traffic configuration as the standard.

**Measurement Offset**

The spectrum analysis output plots shows the peak of the CDMA channel signal 16.19 dB below the Mask reference / “zero dBc line” of the spectrum analyzer for the following reason: For the CDMA system there is no carrier without modulation. Since the CDMA signal is broadband and 1.25 MHz wide, all measurements performed at narrower resolution bandwidths need be adjusted for the reduction in signal energy. The following relationship was used to provide the correct level for an unmodulated carrier vs. the broadband modulated signal.

$$10*\log (\text{Resolution Bandwidth/ Transmit Bandwidth}) = \text{Signal Offset} \tag{1}$$

For the peak of the 1.25 MHz CDMA signal measured with a RBW of 30 kHz the signal offset is:

$$\text{Signal Offset} = 10*\log (30 \text{ kHz} / 1.25 \text{ MHz} ) = -16.19 \text{ dB}$$

Limits which are specified as appropriate at a given RBW can be measured and evaluated at other RBW’s if the limit is adjusted per equation (1)

**Exhibit 14** *continued*

**Require Levels**

The minimum standard presented in 3GPP2 C.S0010-C v2.0, 24 February 2006 was followed for Suppression inside the Licensee’s Frequency Block(s)

Signals that are within the base station transmit band of 1930.000 to 1990.000 MHz and are within the specific block(s) allocated to the operator's system, the total conducted spurious emissions in any 30 kHz band greater than 885 kHz from the CDMA channel center frequency shall not exceed a level of -45 dBc....

The Limit in 47 CFR 24.238(a)(b) for emissions in the 1 MHz band immediately outside and adjacent to a licensee's frequency block is:

Emissions  $\leq 1$  MHz outside the Block *when measured with a RBW of 1%* of the emissions Bandwidth shall be attenuated by :

$$-\{43+10\log(\text{mean power output in watts})\} = -13 \text{ dBm}$$

The Limit in 47 CFR 24.238(a) for emissions outside a licensee's frequency block is:

Emissions  $> 1$  MHz outside the Block, *when measured with a RBW of 1 MHz*, shall be attenuated by :

$$-\{43+10\log(\text{mean power output in watts})\} = -13 \text{ dBm.}$$

Measurement at a Resolution Bandwidth of 30 kHz is based on our experience with 47 CFR 24.238 and lacking other guidance.

**Adjusted Levels**

The following levels apply when measurement of the above limits are performed with an RBW of 30 kHz. Measurement at a Resolution Bandwidth of 30 kHz is based on our experience with 47 CFR 24.238 and lacking other guidance.

1. On any frequency removed from the carrier center frequency by greater than 885 kHz up to 1.25 MHz - at least 45 decibels below the carrier; and
2. On any frequency removed from the carrier center frequency by greater than 1.25 MHz to 2.25 MHz the level shall not exceed -9.2 dBm when measured in a 30 kHz resolution bandwidth (Note 2 below).  
 For a single carrier at 40 Watts per carrier the required level is -9.2 dBm  
 For a single carrier at 20 Watts per carrier the required level is -9.2 dBm  
 For multiple carriers at 40 Watts per carrier the required level is -9.2 dBm
3. From the edge of the Block to the 10th harmonic of the carrier at least

$$-\{43+10\log(\text{mean power output in watts})\} \text{ dBm.}$$

**For single and multiple 1.25 MHz bandwidth carriers at 20 or 40 Watts per carrier...** the required level is -28.2 dBm as measured with a 30 kHz resolution bandwidth (see Note 3). This is equal to -13 dBm measured with a 1 MHz resolution bandwidth.

++++  
**Note 2:** The -9.2 dBm level was computed as follows: The limit is specified as

$$-\{43+10\log(\text{mean power output in watts})\} \text{ dB} = -13 \text{ dBm}$$

When measured in a resolution bandwidth not less than 1% of the signal bandwidth.  
Since the carrier is a 1.25 MHz bandwidth signal, the limit is adjusted to

$$-13 + 10\text{LOG}(30\text{kHz}/12.5 \text{ kHz}) \text{ dBm} = -9.2 \text{ dBm}; \text{ which given a } 46.02 \text{ dBm carrier (40W) equals } -55.22 \text{ dBc}$$

**Note 3:** The -28.2 dBm level is computed from -13 dBm measured with a 1 MHz resolution bandwidth adjusted by :

$$-13 + 10\text{LOG}(30\text{kHz}/1.0 \text{ MHz}) \text{ dBm} = -28.2 \text{ dBm}; \text{ which given a } 46.02 \text{ dBm carrier (40W) equals } -74.22 \text{ dBc}$$

**Exhibit 14** *continued*

**Mask Description for a Single Carrier in a 40 Watts Total Power application.**

The Mask limits are identical for the left and right side of the PCS Blocks and are as follows:

Figure 14B shows the Mask limit for PCS channel 25 which is the left block edge for Block A and shows limits levels identical for the band edge of the PCS band. The Spectrum Analyzer reference level is set above the Signal Reference to allow for the necessary dynamic range of a CDMA carrier presentation. The top of a typical 46.02 dBm single carrier CDMA signal viewed at a resolution bandwidth of 30 kHz is shown at the 29.82 dBm/ -16.2 dBc line. This line is based on equation 1, and the ratio of the 1.25 MHz bandwidth and the 30 kHz resolution bandwidth of the spectrum analyzer. The vertical line from a to b (i.e. a-b) is at 885 kHz from the center of channel 25 (i.e.  $f_c$ ), per 3GPP2 TSG-C.S0010-C-v2.0. The horizontal line b-c is 45 dB below the 46.02 dBm/ 0 dBc reference level. The vertical line c-d is at 1.25 MHz from the center of the channel. The placement of line d-e is derived from evaluation of the signal and 12.5 kHz (1%) resolution bandwidth, using the suggested value in section 24.238 of the rules. The ratio of 30 kHz to 12.5 kHz in equation (1) gives 3.8 dB. Adjusting the tolerance line to reflect this difference puts the -13 dBm limit line at -9.2 dBm or -55.22 dBc below the top of mask reference line. The vertical line, e-f is at 2.25 MHz from the center of channel 25. The horizontal line f-g is drawn at -74.22 dBc below the 0 dBc / 46.02 dBm reference because the rules require a 1 MHz resolution bandwidth for measurements 1 MHz or greater outside the PCS band. Again, equation (1) and the ratio of 1 MHz to 1.25 MHz provides this value. The same logic was used in determining the other block and band edge tolerances.

**Mask Description for Multiple Carriers at 40 Watts Total Power.**

The mask for multiple carriers with a fixed total power adjusts top of mask level and the - 45 dBc level along with the width of the carrier portion of the mask. For the example given above...with multiple carriers there would be no adjustments made to the “Left Edge of Block” requirements. The specified “Right Edge Limit” is treated as an expansion of the non Block edge corner **bb** to be the required + 885 kHz from the center of the “right most” channel. The “Right Edge of Block” limits were derived consistently. Table 14.3 below provides the appropriate levels for the mask break points.

**Trace Description and Power Calibration**

Figure 14B shows the single carrier channel 25 CDMA signal measured with two different resolution bandwidths. The additional upper magenta trace displays the signal as measured with a resolution bandwidth of 3 MHz. The black trace is the same signal as measured with a 30 kHz resolution bandwidth and is the appropriate trace for compliance evaluation against the mask. The wider resolution bandwidth of the magenta trace allows for a true power calibration of the measured signal against the top of mask and calibration of the analyzer to the more accurate power meter. The top of the mask is appropriate for a single carrier power calibration as it represents the true power level of a single carrier as measured with a power meter. For a two carrier signal the total power is 3 dB higher. For a three carrier signal the total power is 4.771 dB higher. The power calibration trace would be appropriately displayed if measured with a resolution bandwidth greater than the signal bandwidth of 3.75 MHz. Spectrum analyzers, however, typically have a maximum resolution bandwidth of 3 MHz and therefore a correction factor is necessary to account for the difference. The bandwidth correction factor for 3 carrier and wider signals (3.75 MHz) as measured with a 3 MHz bandwidth is:

$$-0.969 \text{ dB} = 10 * \text{LOG}(3/3.75)$$

The power calibration line is appropriately adjusted above the top of mask by:

$$4.771 \text{ dB} + 10 * \text{LOG}(3/3.75) \text{ dB} = + 3.800 \text{ dB}$$

The bandwidth corrected power calibration level for 3 or more carriers equals:

$$\text{Single Carrier Power level (dBm)} + 4.77 + 10 * \text{LOG}(3/3.75) = \text{Single Carrier Power level (dBm)} + 3.80 \text{ dB}$$

$$46.02 \text{ dBm} + 3.80 \text{ dB} = 49.82 \text{ dBm}$$

The power calibration value for 2~11 carrier configurations is listed in Table 14.3 above. These values are depicted on the occupied bandwidth charts as the dashed magenta Power Calibration Line h-hh on each chart and as shown in the example chart in Figure 14C.

**Exhibit 14** *continued*

Total Power	Number of amps	Number of carriers	Power per Carrier	Power per Carrier	-45 dBc Lines b-c and bb-cc	1st MHz outside of Block	> 1 MHz Outside of Block	Power Calibration Value	-16.2 dBc Reference line
Watts	n	n	Watts	dBm	dbm	dBm	dBm	dBm	dBm
80	1	2	40.00	46.02	1.02	-9.20	-28.23	49.02	29.82
80	1	4	20.00	43.01	-1.99	-9.20	-28.23	46.81	26.81
80	1	11	7.27	38.62	-6.38	-9.20	-28.23	42.42	22.42
160	2	4	40.00	46.02	1.02	-9.20	-28.23	49.02	29.82
160	2	8	20.00	43.01	-1.99	-9.20	-28.23	46.81	26.81
160	2	11	14.55	41.63	-3.37	-9.20	-28.23	45.43	25.43

**TABLE 14.3 Mask Values for Various Carrier Configurations**

**Measurement of the Two and Four Carrier Configuration**

All of the tolerance lines for the output are referenced to the top of the Occupied Bandwidth mask, which is defined in Table 14.3 above. For all Occupied Bandwidth measurements of the **PCS P4PAM EDPD Transceiver System**, the output power was set to the 40 W total power level using a broadband RF power meter. The Top of Mask value is appropriately the value in Table 14.3 for the specific number of carriers. When the magenta trace is adjusted to the power calibration line the 30 kHz signal trace will be correctly set to the -16.2 dBc reference line. Comparison of the 30 kHz measurement to the Mask is then appropriate and accurate.

In order to depict the tolerance lines per Table 14.3 that are required by Sec 24.238 of the FCC Rules and 3GPP2 C.S0010-C v2.0, all measurements were made with a resolution bandwidth of 30 kHz and the limits were adjusted using equation (1). A sample detector was employed using minimum of 25 sweeps averaging per trace.

**Exhibit 14** *continued*

PCS - Block	PCS -Channels		Number of carriers	Power per Carrier, W/c	Number of Amplifiers	Total Power Watts	Results Occupied Bandwidth
<b>Single amplifier 2 Carrier Configuration</b>							
A	25-50	250-275	2	40	1	80	Compliant
D	325-350	350-375	2	40	1	80	Compliant
B	425-450	650-675	2	40	1	80	Compliant
E	725-750	750-775	2	40	1	80	Compliant
F	825-850	850-875	2	40	1	80	Compliant
C	925-950	1150-1175	2	40	1	80	Compliant
G	1225-1250	1250-1275	2	40	1	80	Compliant
<b>Single amplifier 4 Carrier Configuration</b>							
A	25-100	200-275	4	20	1	80	Compliant
D	325-400		4	20	1	80	Compliant
B	425-500	600-675	4	20	1	80	Compliant
E	700-775		4	20	1	80	Compliant
F	825-900		4	20	1	80	Compliant
C	925-1000	1100-1175	4	20	1	80	Compliant
G	1200-1275		4	20	1	80	Compliant
<b>Two amplifier 4 Carrier Configuration</b>							
A	25-100	200-275	4	40	2	160	Compliant
AD	325-400		4	40	2	160	Compliant
B	425-500	600-675	4	40	2	160	Compliant
BE	700-775		4	40	2	160	Compliant
FC	825-900		4	40	2	160	Compliant
C	925-1000	1100-1175	4	40	2	160	Compliant
CG	1200-1275		4	40	2	160	Compliant
<b>Two amplifier 8 Carrier Configuration</b>							
A	25-100	200-275	8	20	2	160	Compliant
AD	325-400		8	20	2	160	Compliant
B	425-500	600-675	8	20	2	160	Compliant
BE	700-775		8	20	2	160	Compliant
FC	825-900		8	20	2	160	Compliant
C	925-1000	1100-1175	8	20	2	160	Compliant
CG	1200-1275		8	20	2	160	Compliant

**TABLE 14.4 PCS Occupied Bandwidth Compliance Tabulation**

**Results**

*The Block designation, PCS channels, frequencies and Measured RF Power are tabulated on each plot. The transmitter output signals are plotted for each frequency/ channel of interest. Plots are provided for Left Edge and Right Edge of each PCS Block evaluated. These frequencies were chosen to show the occupied bandwidth in the channels in each of the PCS Blocks in which this product can be operated, in compliance with Section 24.229 and 24.238 (c) of the Commission code. The signal used to show the occupied bandwidth is defined in table 14.1. This is the signal recommended in 3GPP2 C.S0010-C v2.0. The power output level was adjusted to provide the documented value on each chart. W .Steve Majkowski*

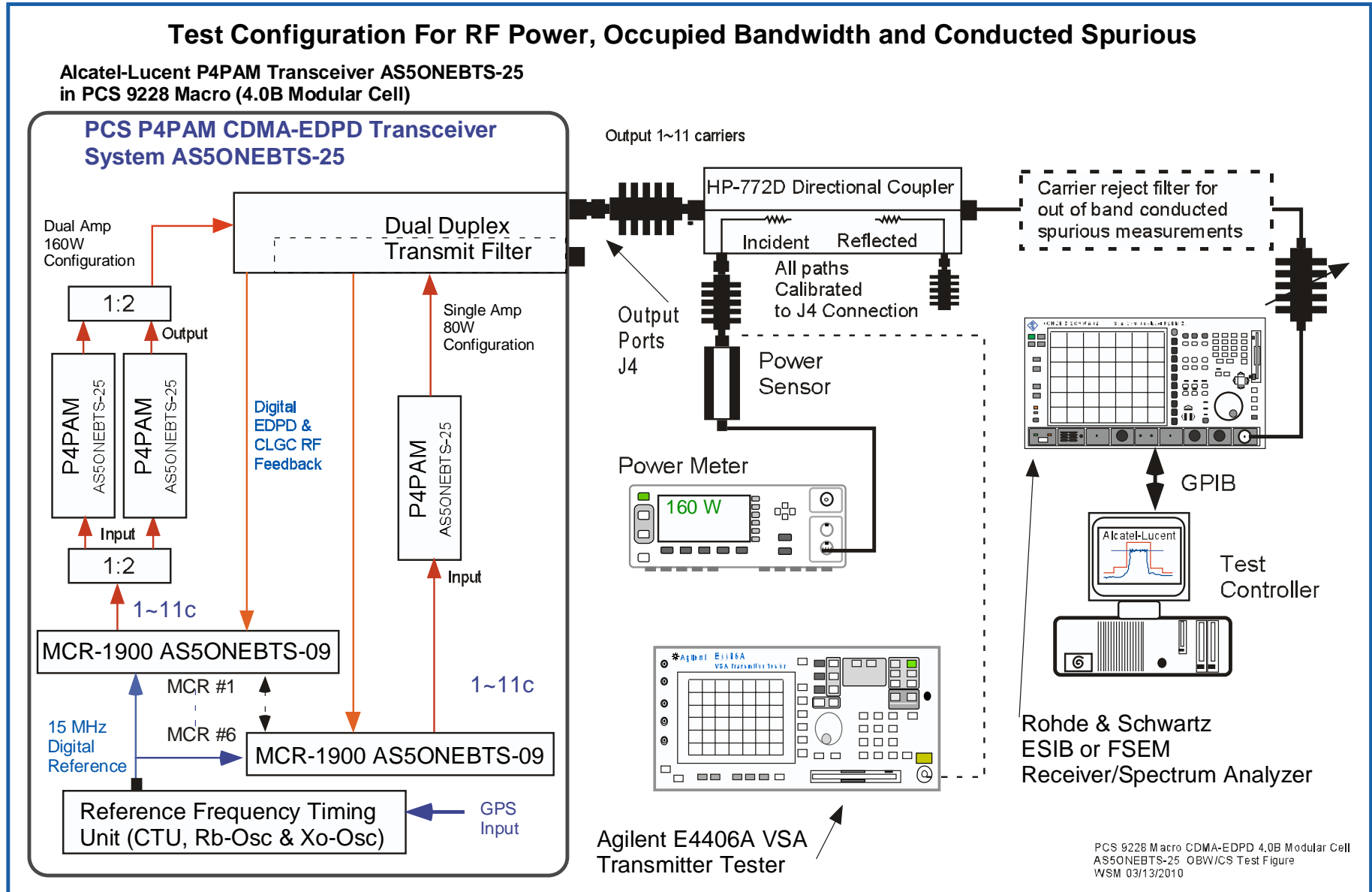
**Conclusion**

The above data demonstrates that the **PCS P4PAM EDPD Transceiver System / FCC ID: AS5ONEBTS-25**, the subject of this application, complies with Sections 2.1053, 24.238 and 2.1049 of the Rules.

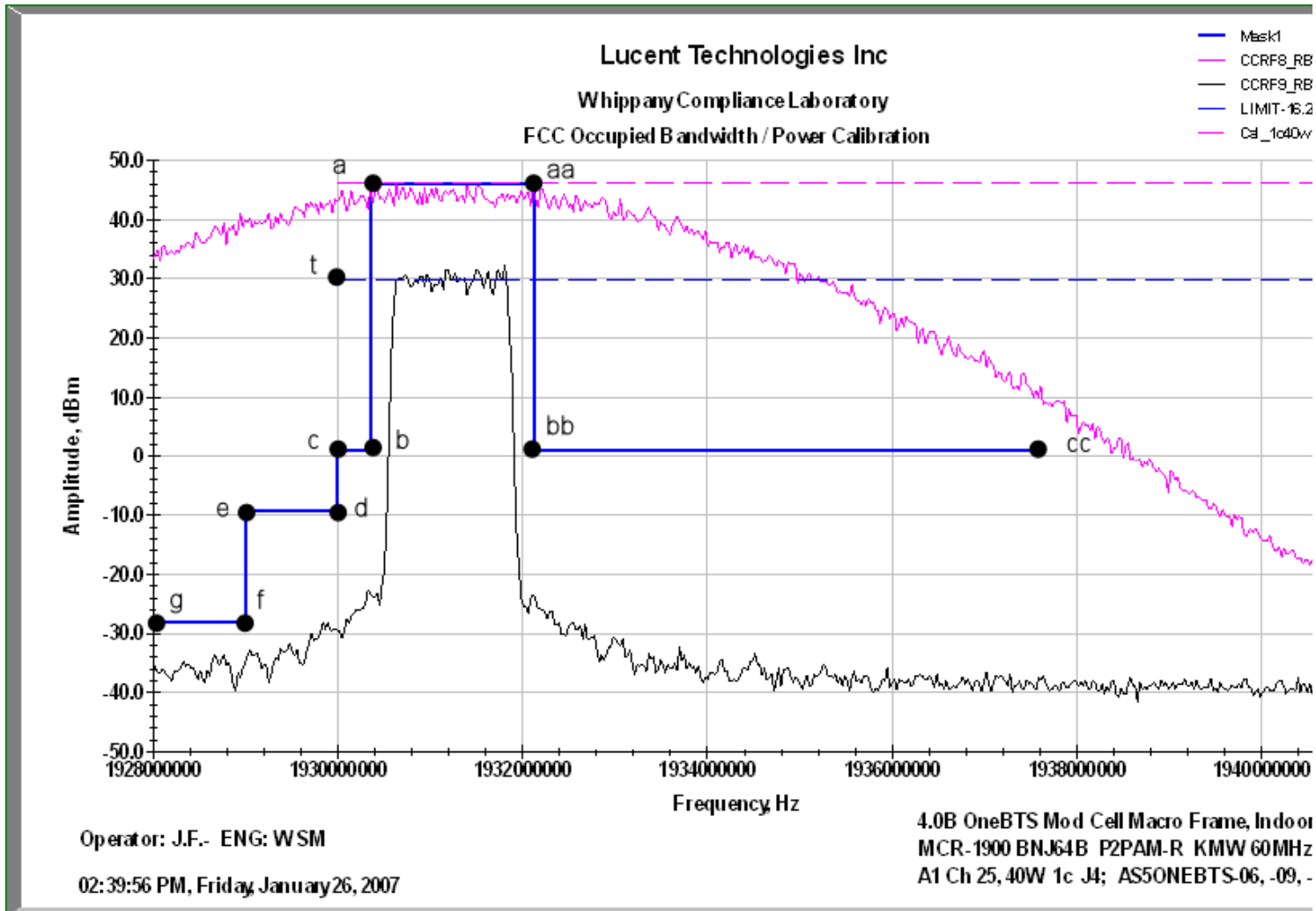




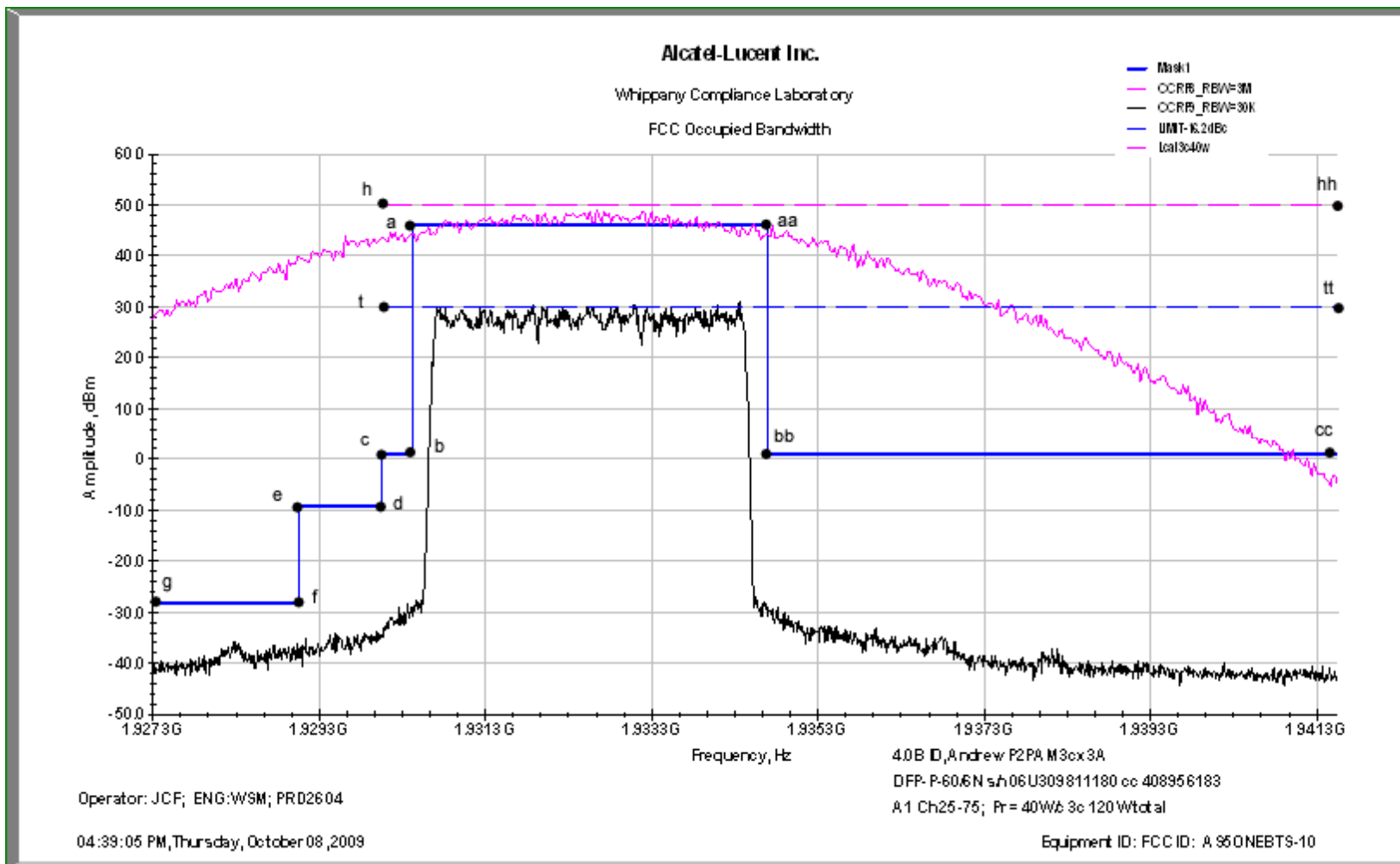
Figure 14A Test Setup for Antenna Port Measurement of Transmit Power, Occupied Bandwidth and Conducted Spurious Emissions



**Figure 14B Occupied Bandwidth Power Calibration**  
(PCS A Block is depicted with a single carrier signal showing use of the Power Calibration Trace )



**Figure 14C Multi-Carrier Occupied Bandwidth Power Calibration**  
(PCS A Block is depicted with a three carrier signal showing use of the Power Calibration Trace )



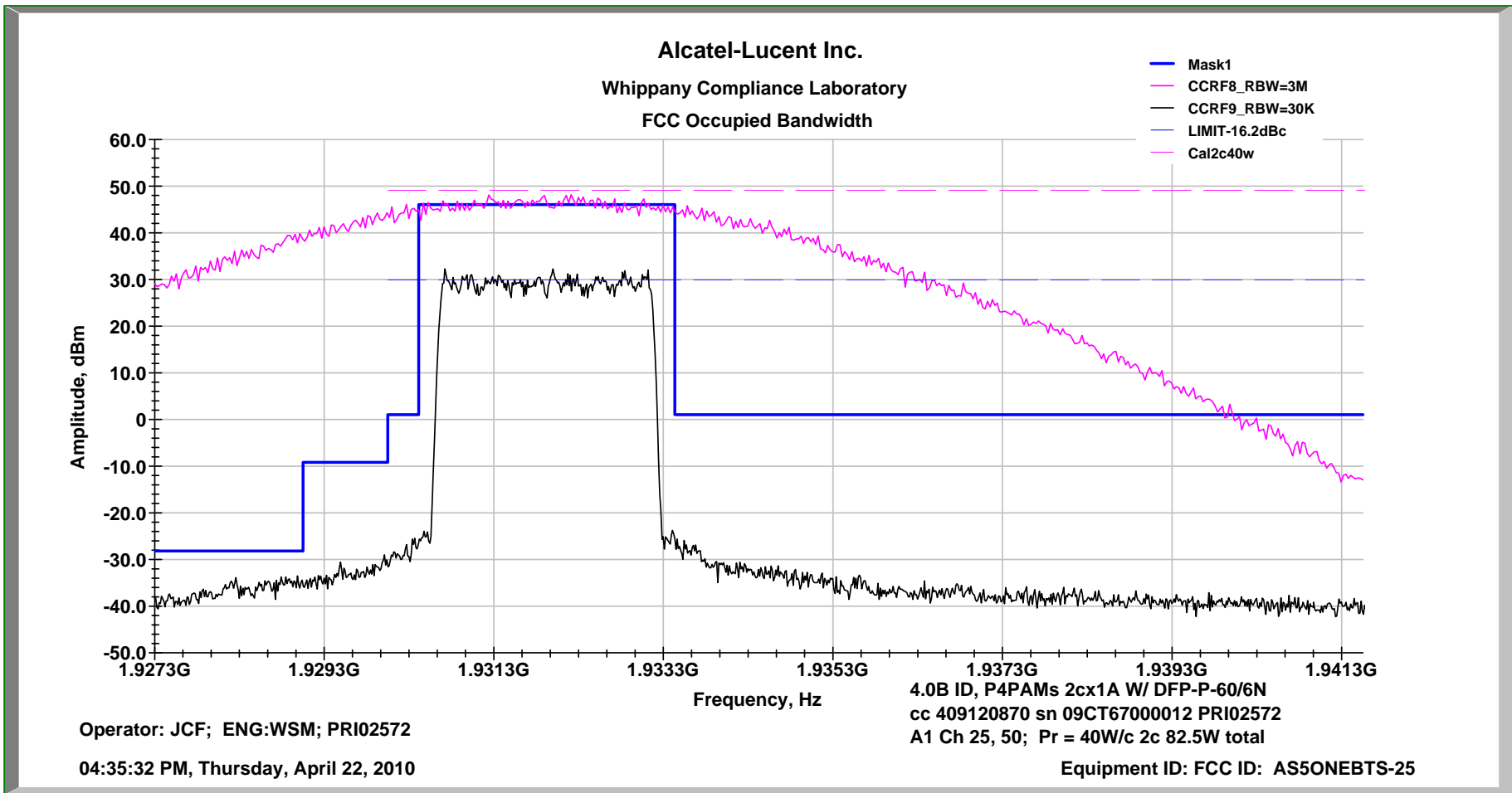
**Transmitter Measurements  
of  
CDMA Occupied Bandwidth  
for  
Alcatel-Lucent Inc.  
PCS P4PAM EDPD Transceiver System  
FCC ID: AS50NEBTS-25  
As Operated In  
9228 Base Station Macro (Formally 4.0B Modular Cell)  
One and Two Amplifier Configurations  
CDMA Operation at  
80W per Amplifier**

W. Steve Majkowski NCE  
CDMA Certification  
Whippany FCC Compliance Laboratory  
Alcatel-Lucent.  
Lab: 973-386-2135  
[majkowski@alcatel-lucent.com](mailto:majkowski@alcatel-lucent.com)

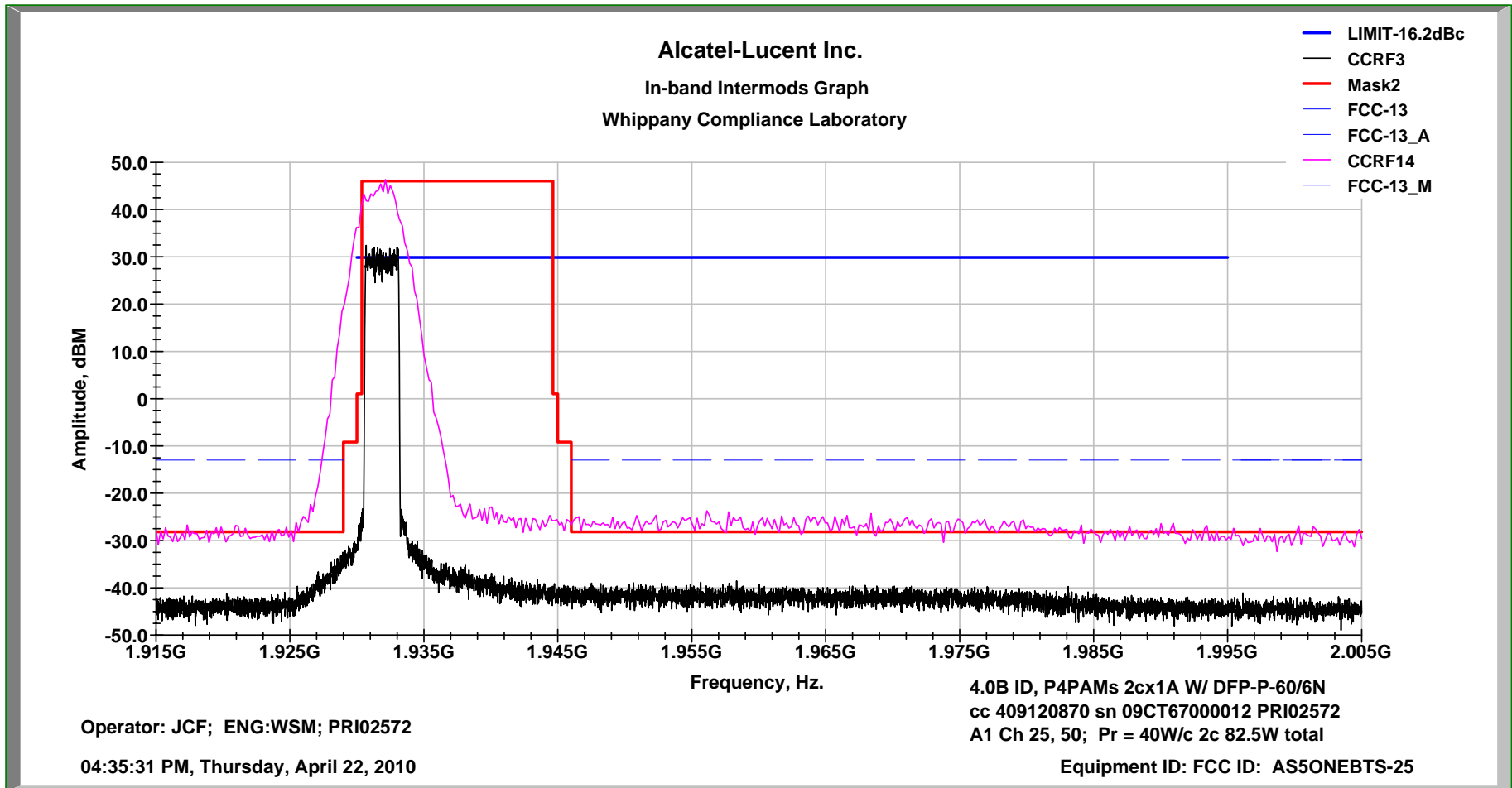
**Single Amplifier Two Carrier  
80 W/Amp 80W Total  
Occupied Bandwidth Data  
PCS Blocks A through G  
Left side of Block, Right side of Block  
And  
PCS Band Intermodulation**

**2c x 1A 40W/c**

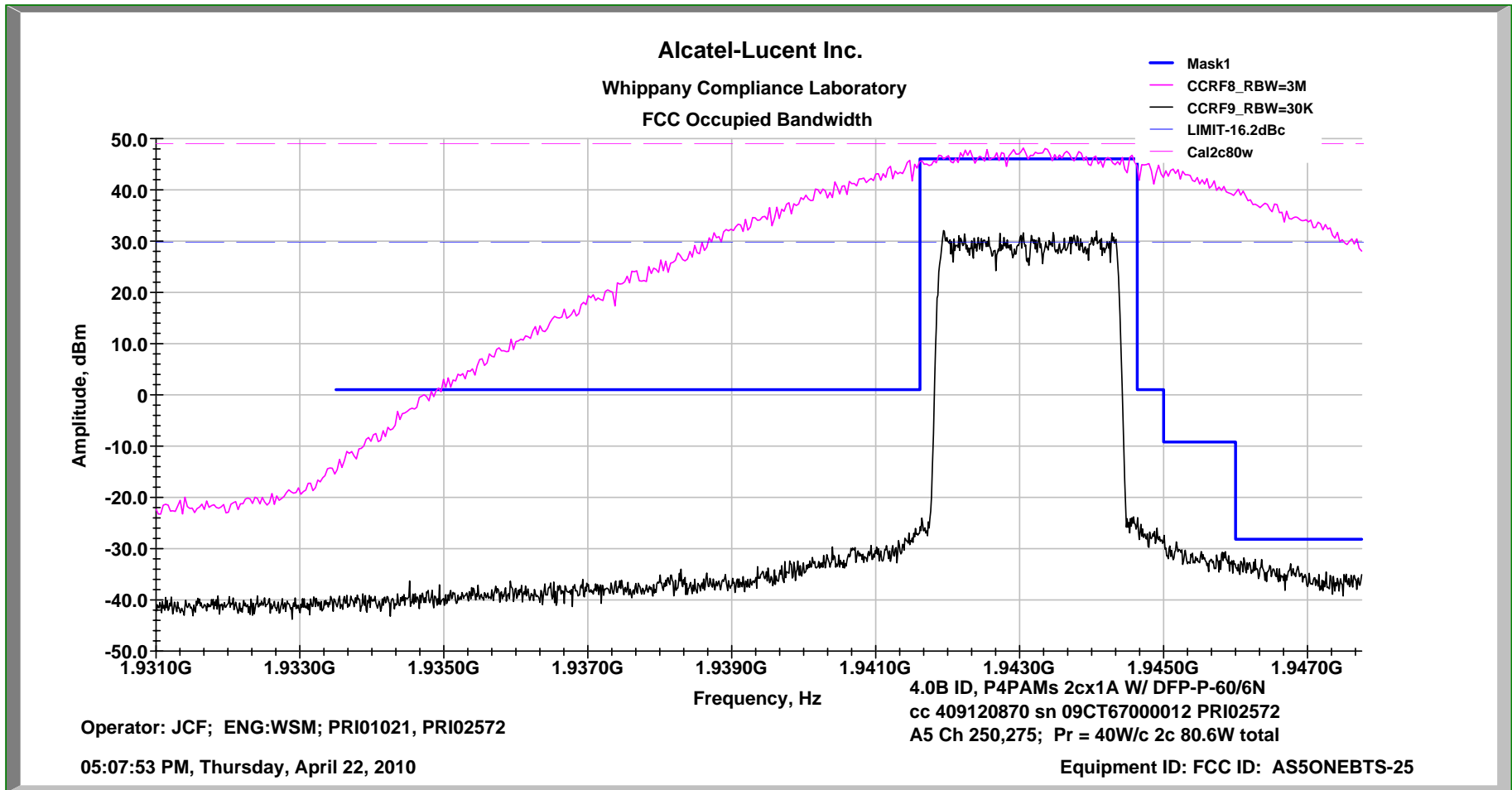
**Occupied Bandwidth PCS Ch A1-25, 50 Andrew P4PAM 2cx1A 40W/c 80W Total**



**In-band Inter-modulation    PCS Ch A1-25, 50    Andrew P4PAM 2cx1A 40W/c 80W Total**

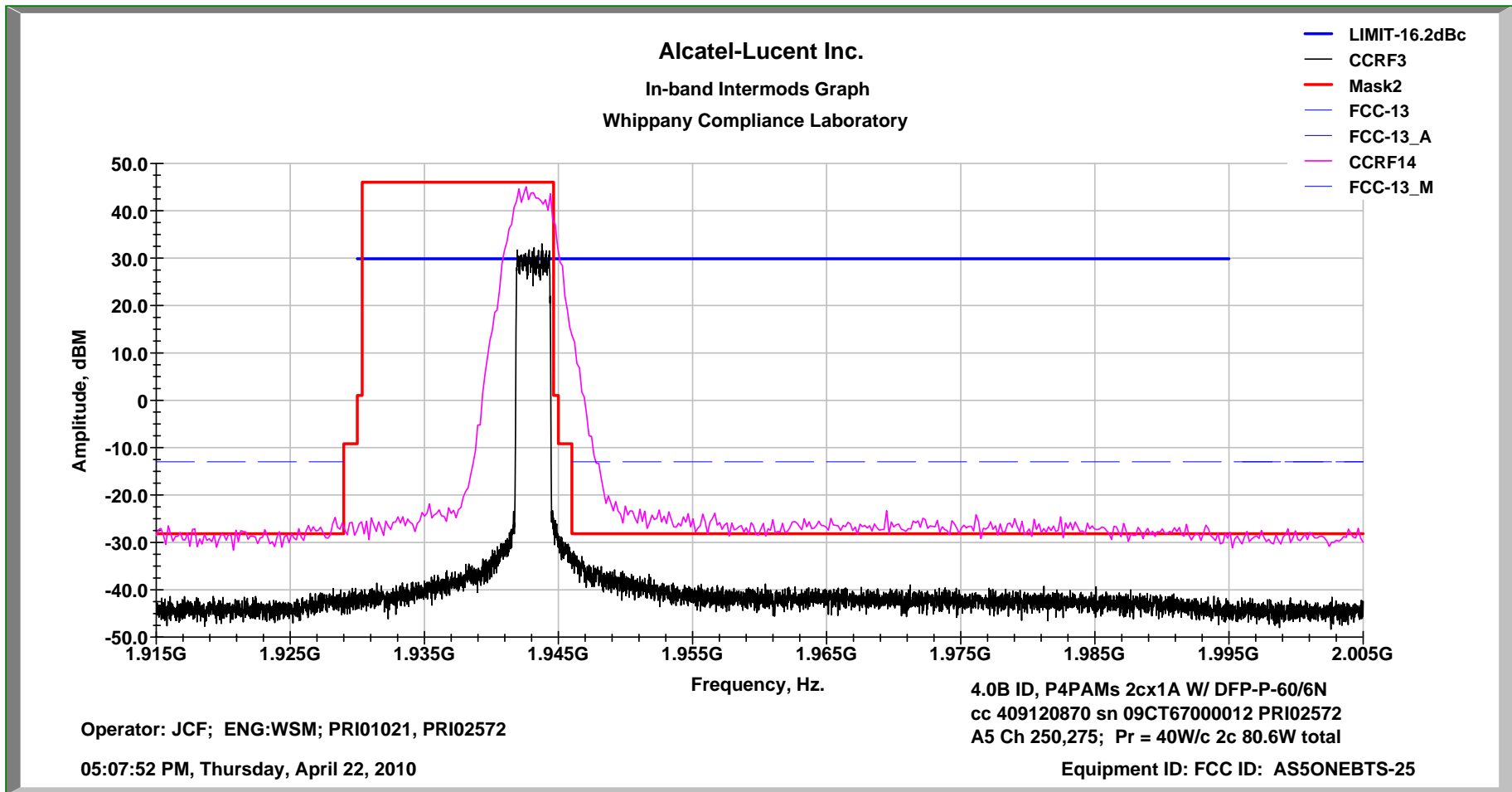


**Occupied Bandwidth PCS Ch A5-250, 275 Andrew P4PAM 2cx1A 40W/c 80W Total**

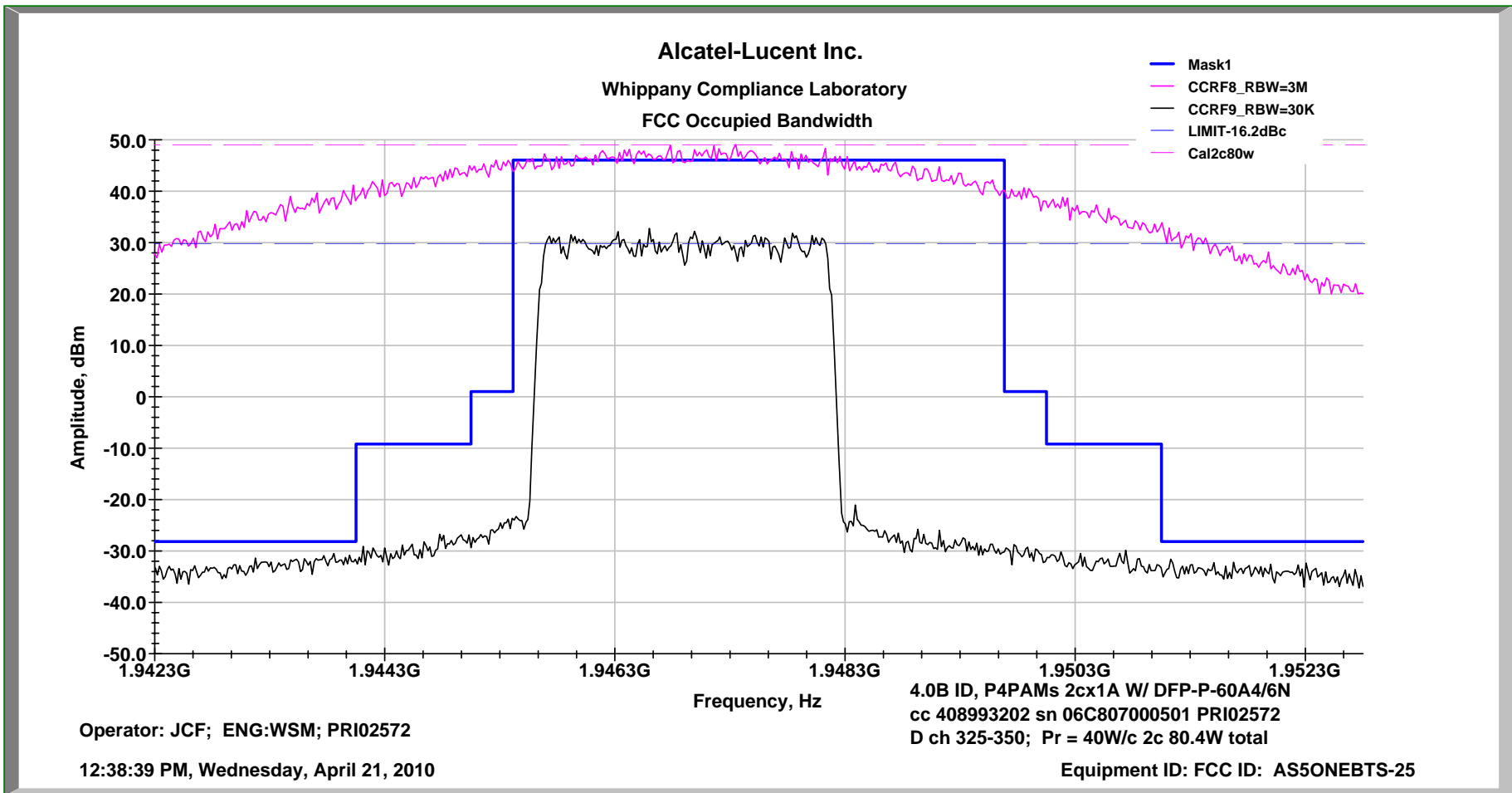




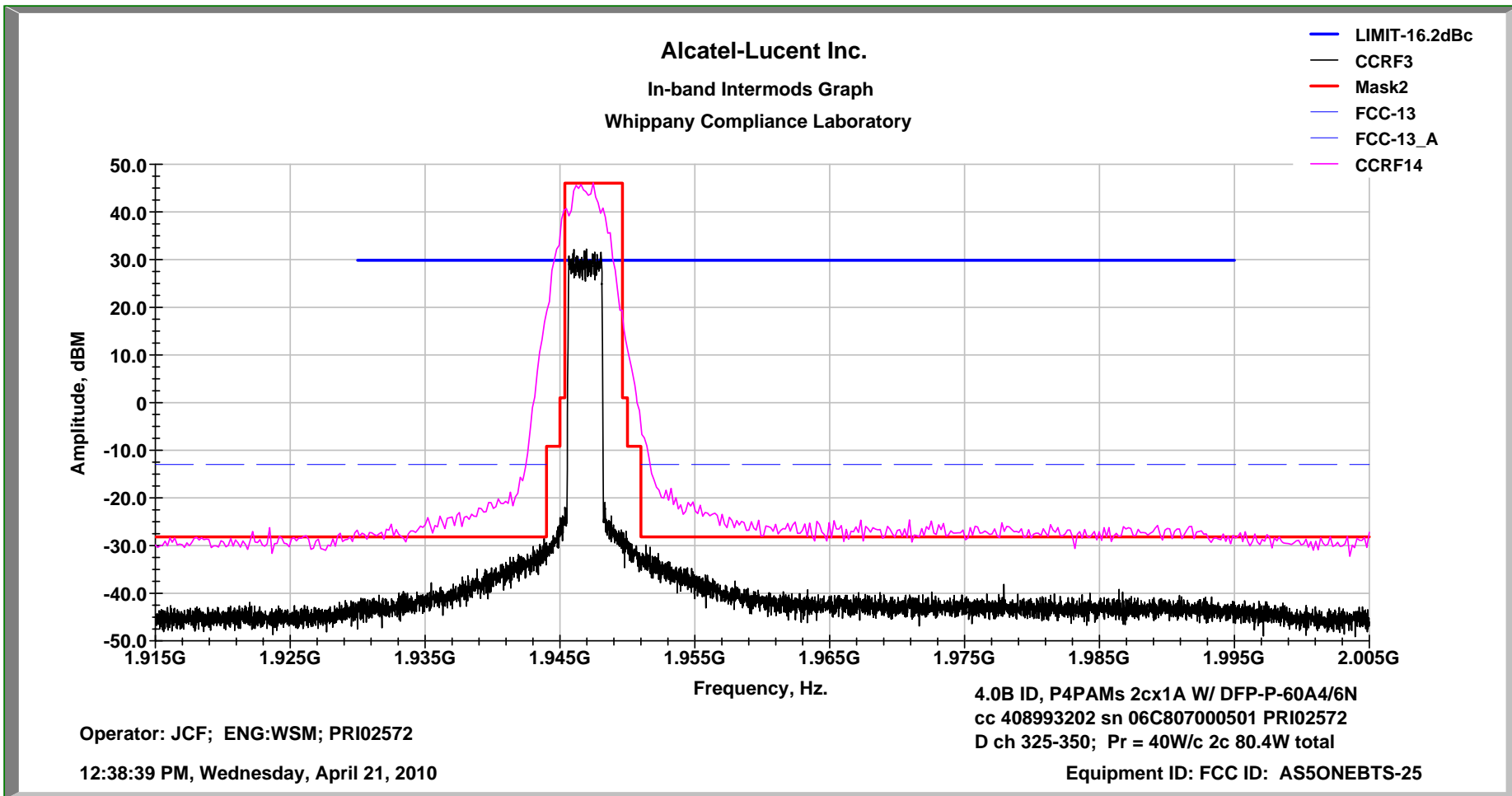
**In-band Inter-modulation    PCS Ch A5-250, 275    Andrew P4PAM 2cx1A 40W/c 80W Total**



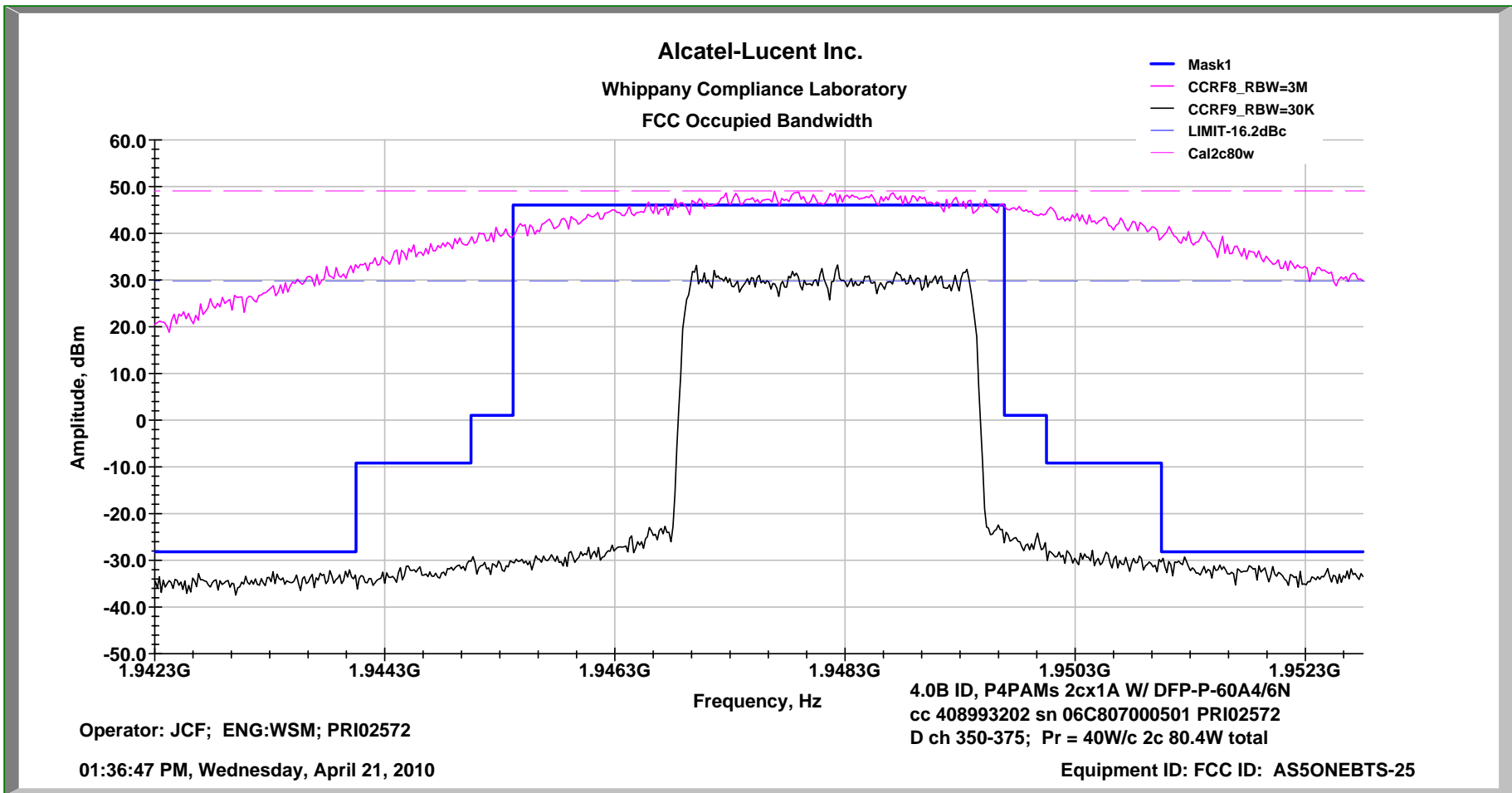
**Occupied Bandwidth PCS Ch DL-300, 325 Andrew P4PAM 2cx1A 40W/c 80W Total**



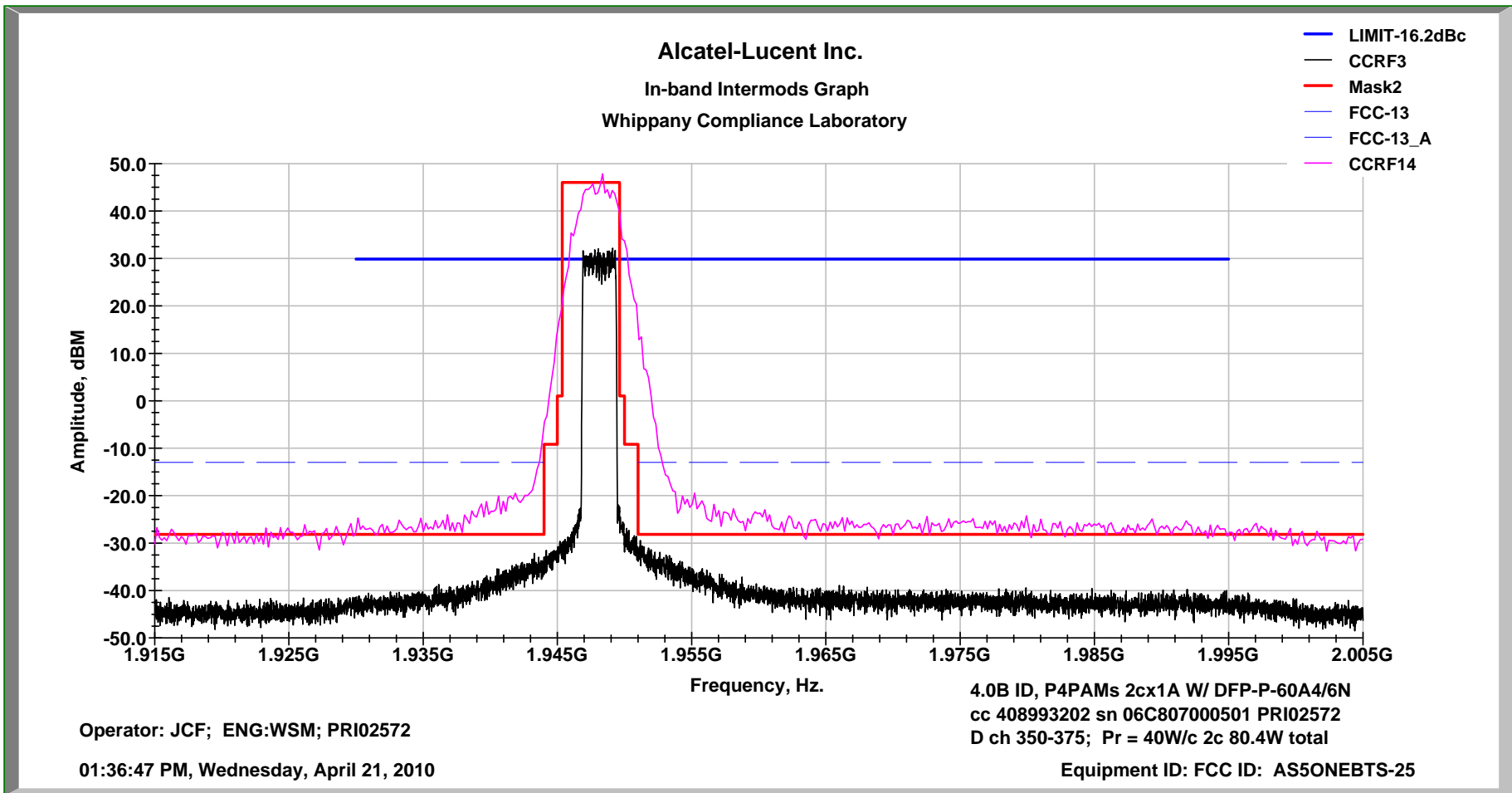
**In-band Inter-modulation    PCS Ch DL-300, 325    Andrew P4PAM 2cx1A 40W/c 80W Total**



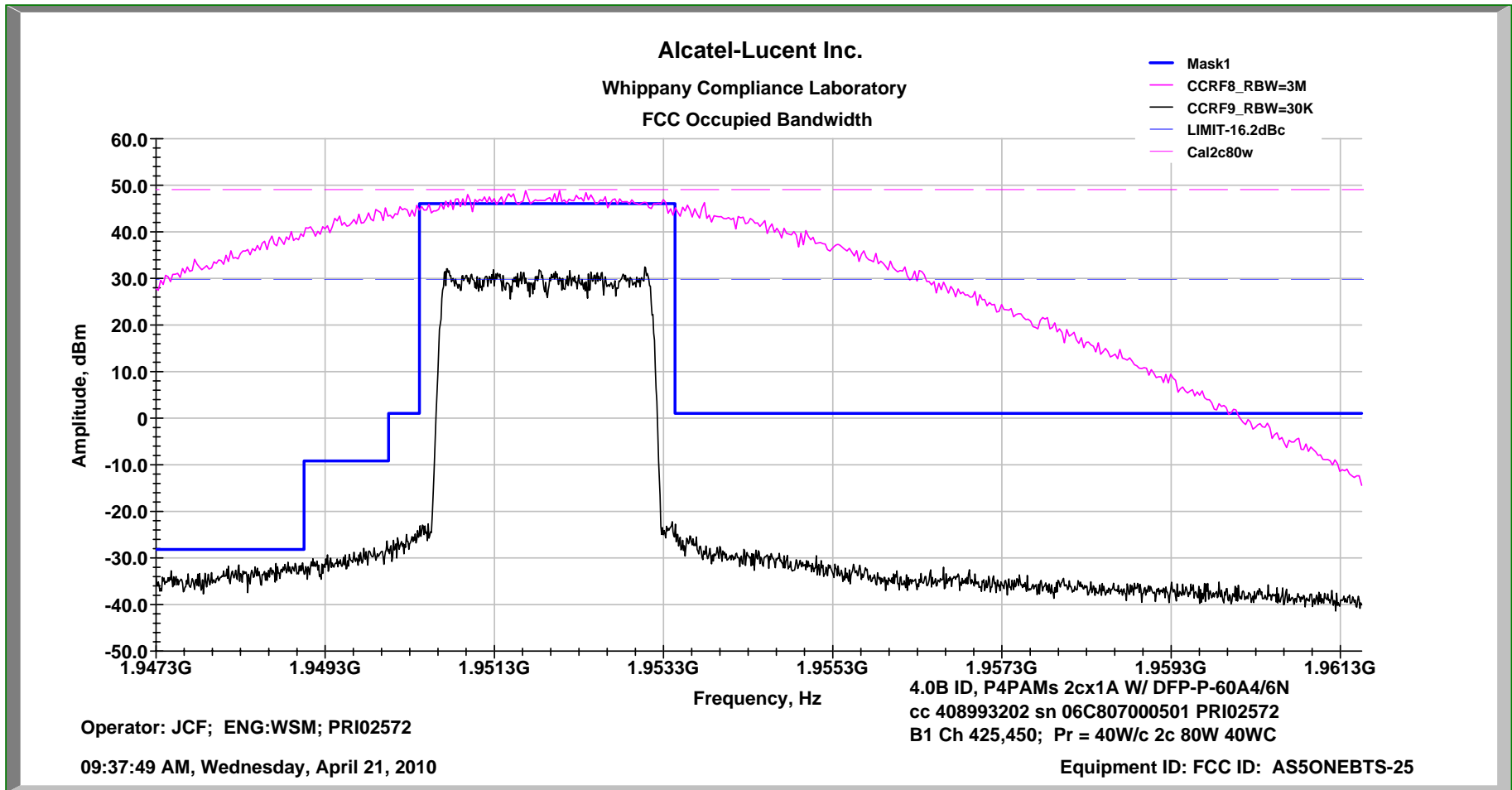
**Occupied Bandwidth PCS Ch DR-325, 350 Andrew P4PAM 2cx1A 40W/c 80W Total**



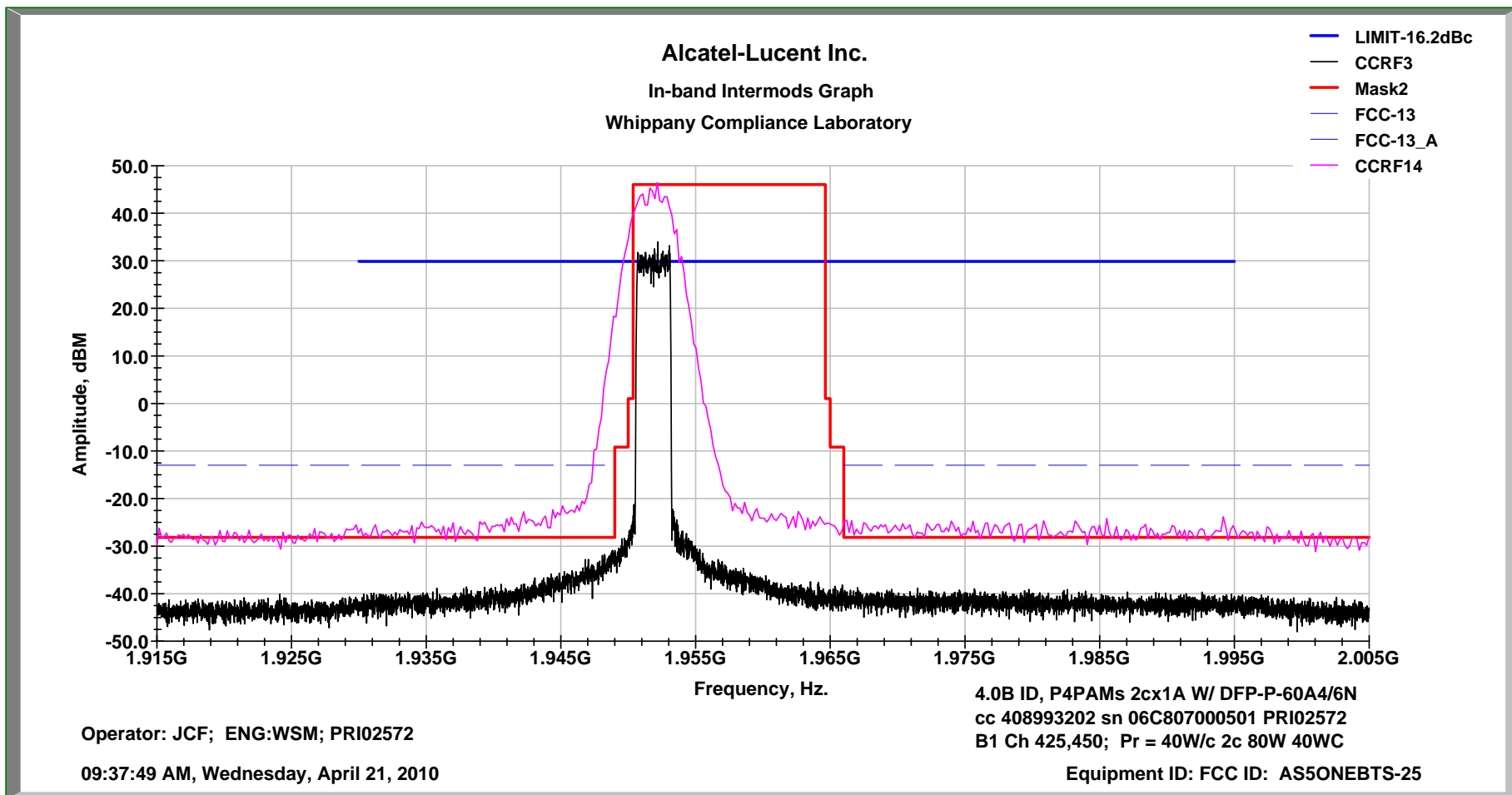
**In-band Inter-modulation    PCS Ch DR-325, 350    Andrew P4PAM 2cx1A 40W/c 80W Total**



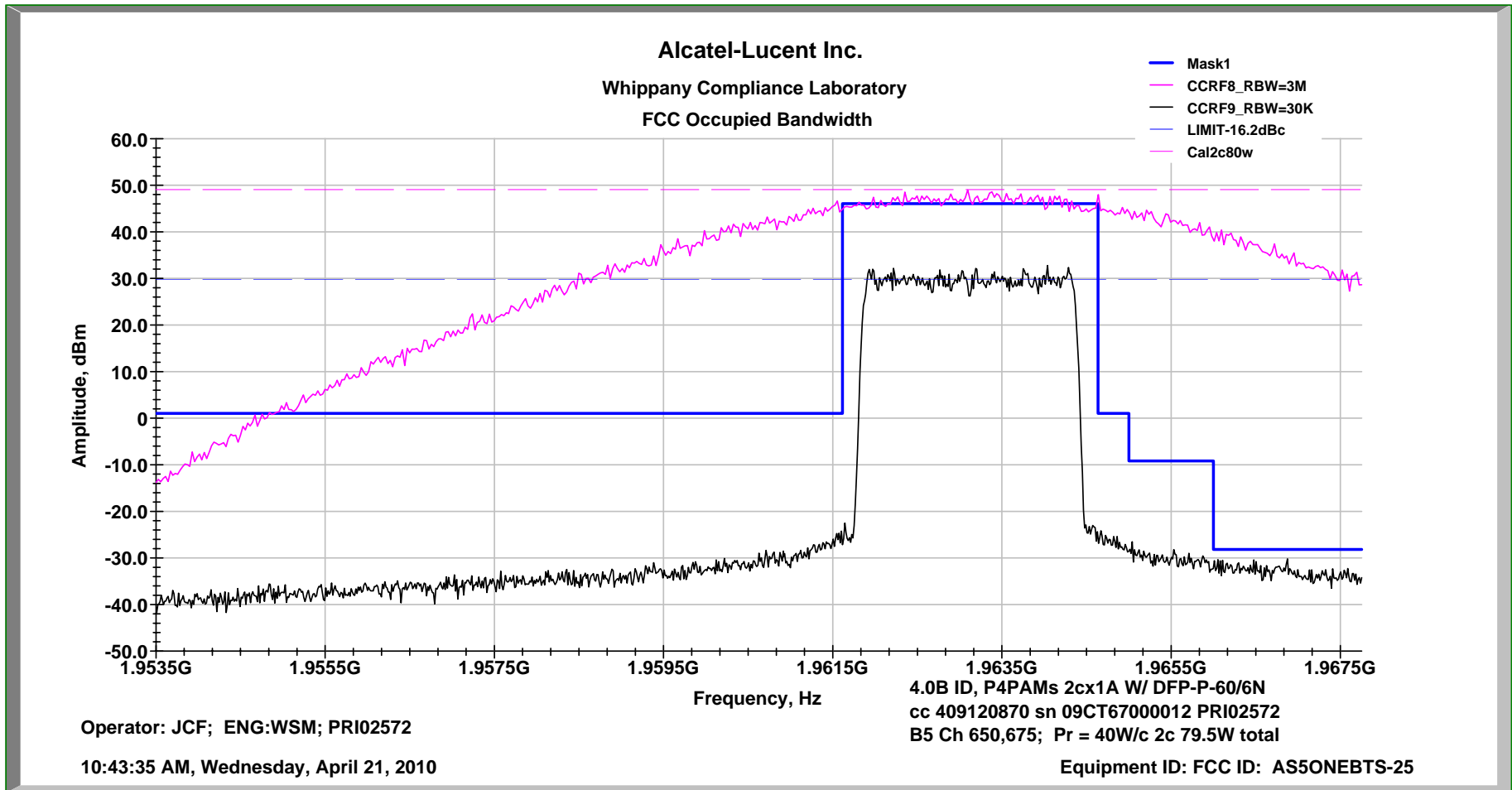
**Occupied Bandwidth PCS Ch B1-425, 450 Andrew P4PAM 2cx1A 40W/c 80W Total**



**In-band Inter-modulation    PCS Ch B1-425, 450    Andrew P4PAM 2cx1A 40W/c 80W Total**

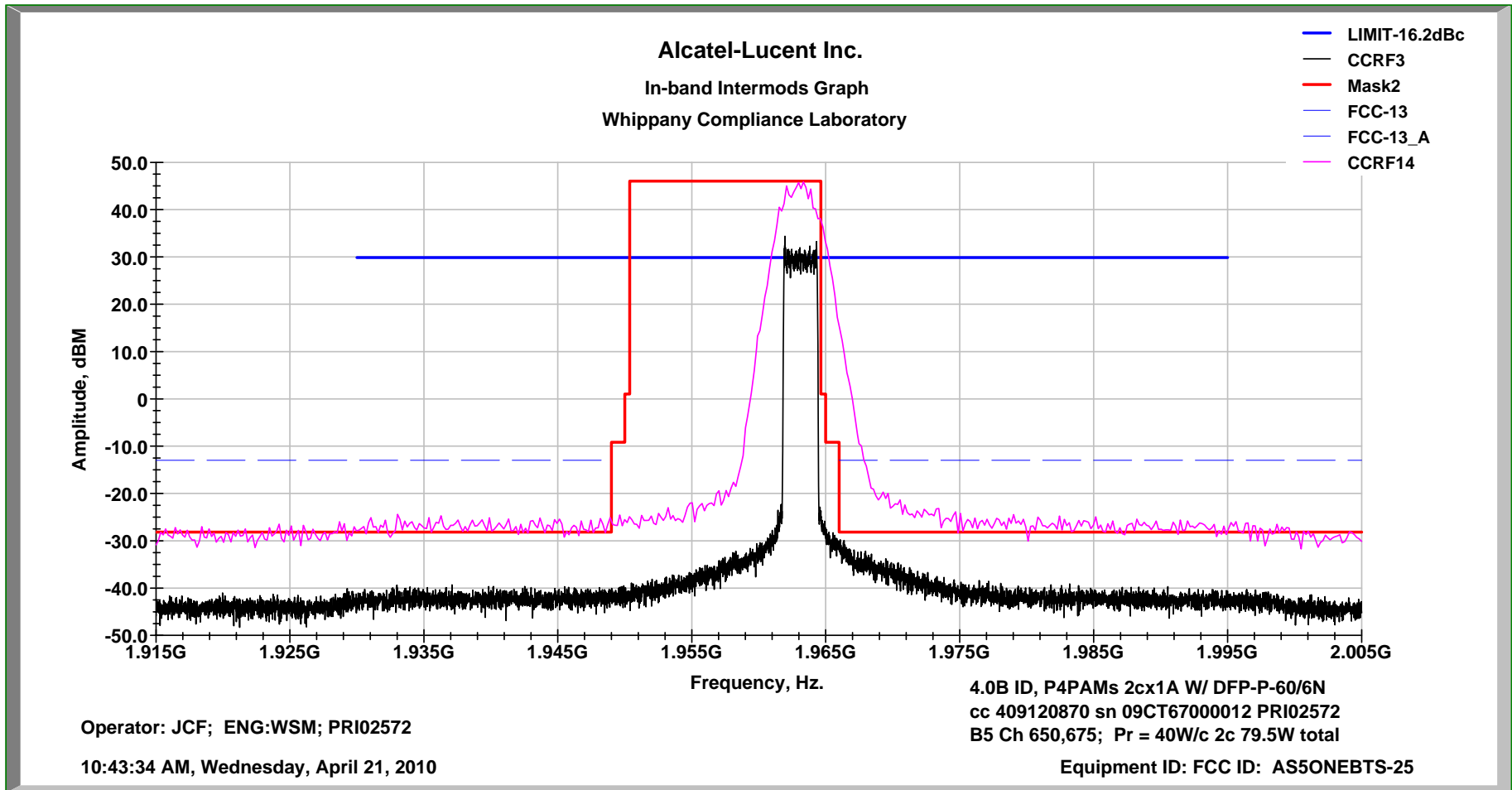


**Occupied Bandwidth PCS Ch B5-650, 675 Andrew P4PAM 2cx1A 40W/c 80W Total**

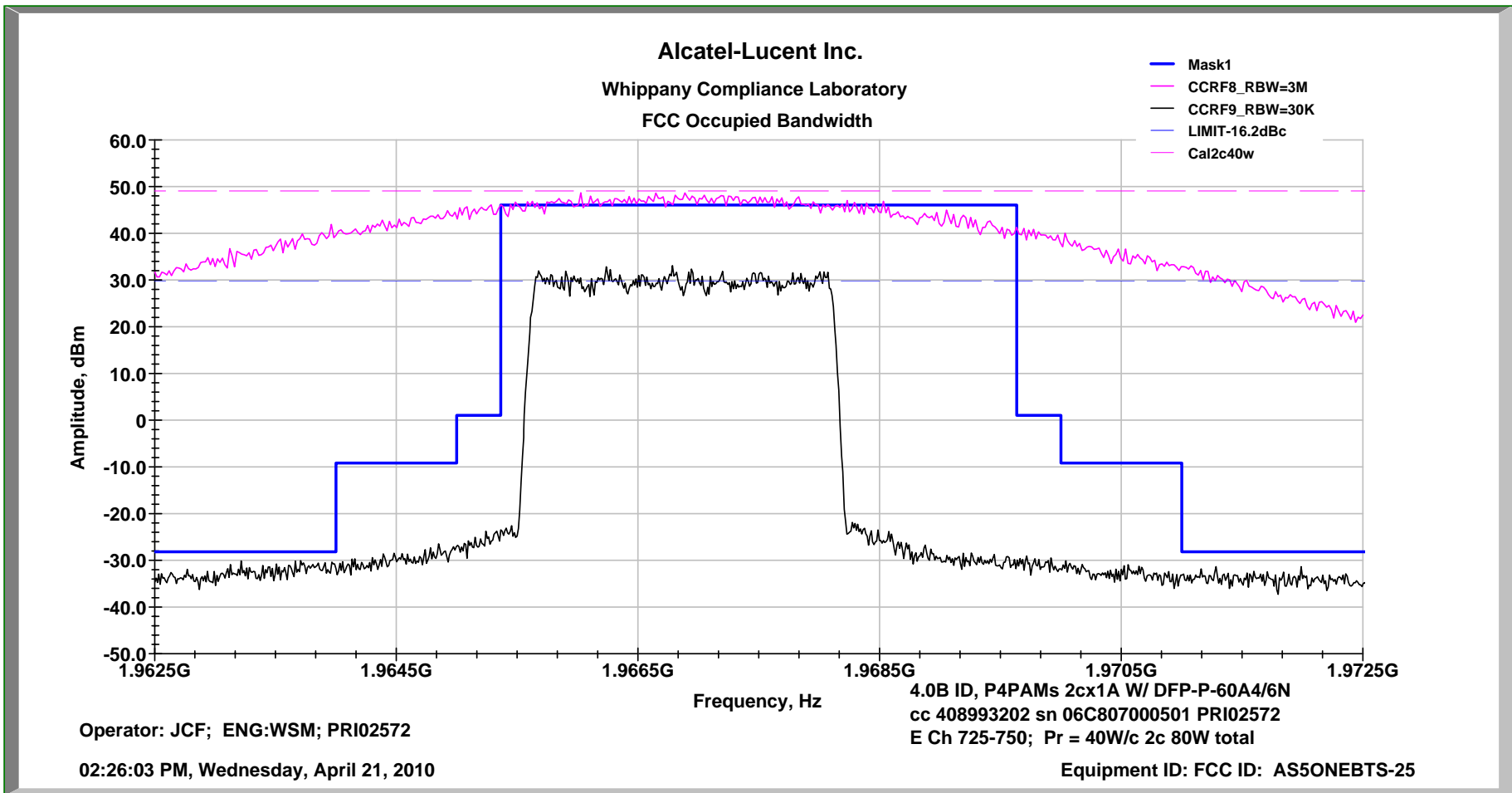




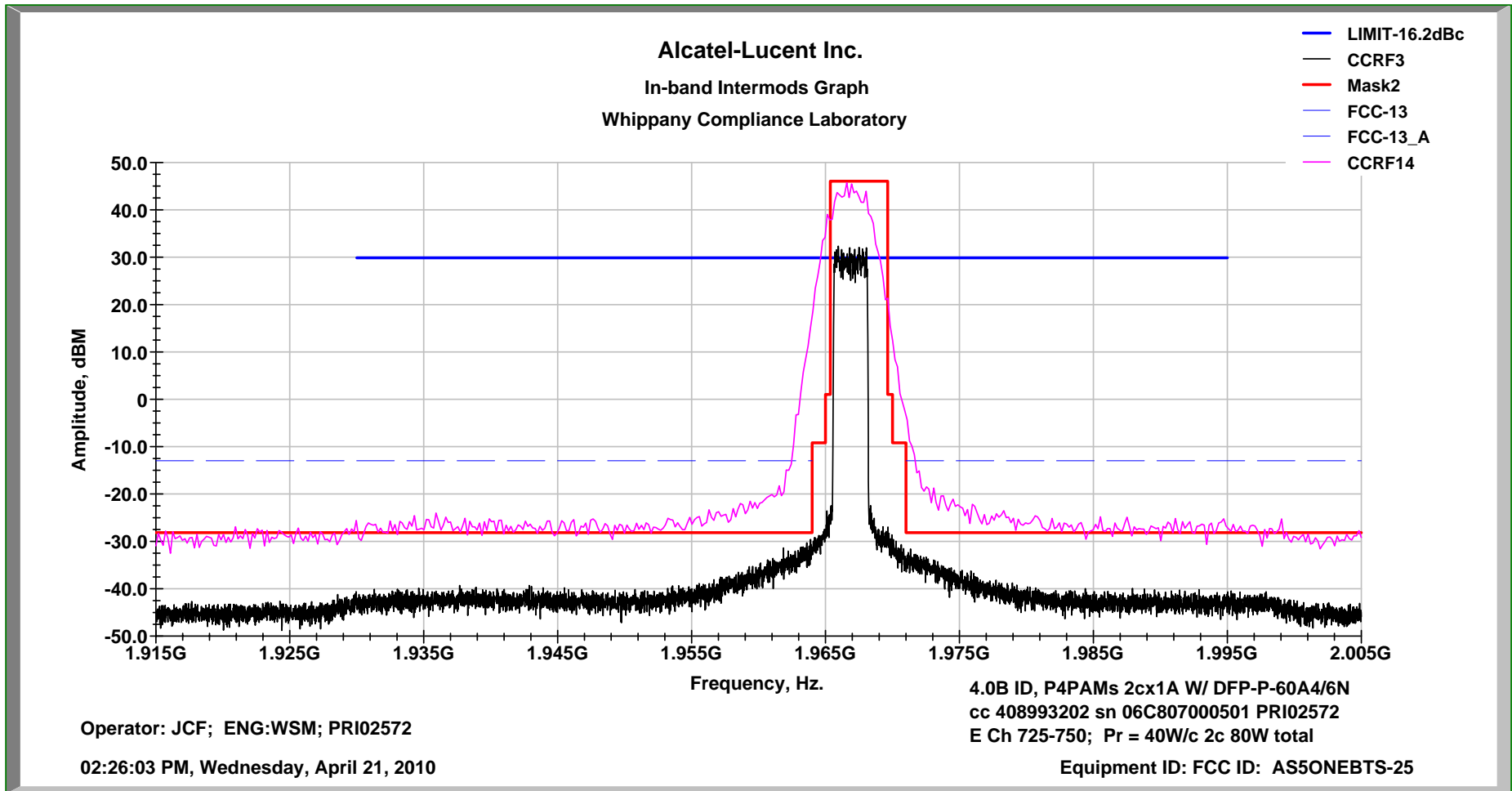
**In-band Inter-modulation    PCS Ch B5-650, 675    Andrew P4PAM 2cx1A    40W/c 80W Total**



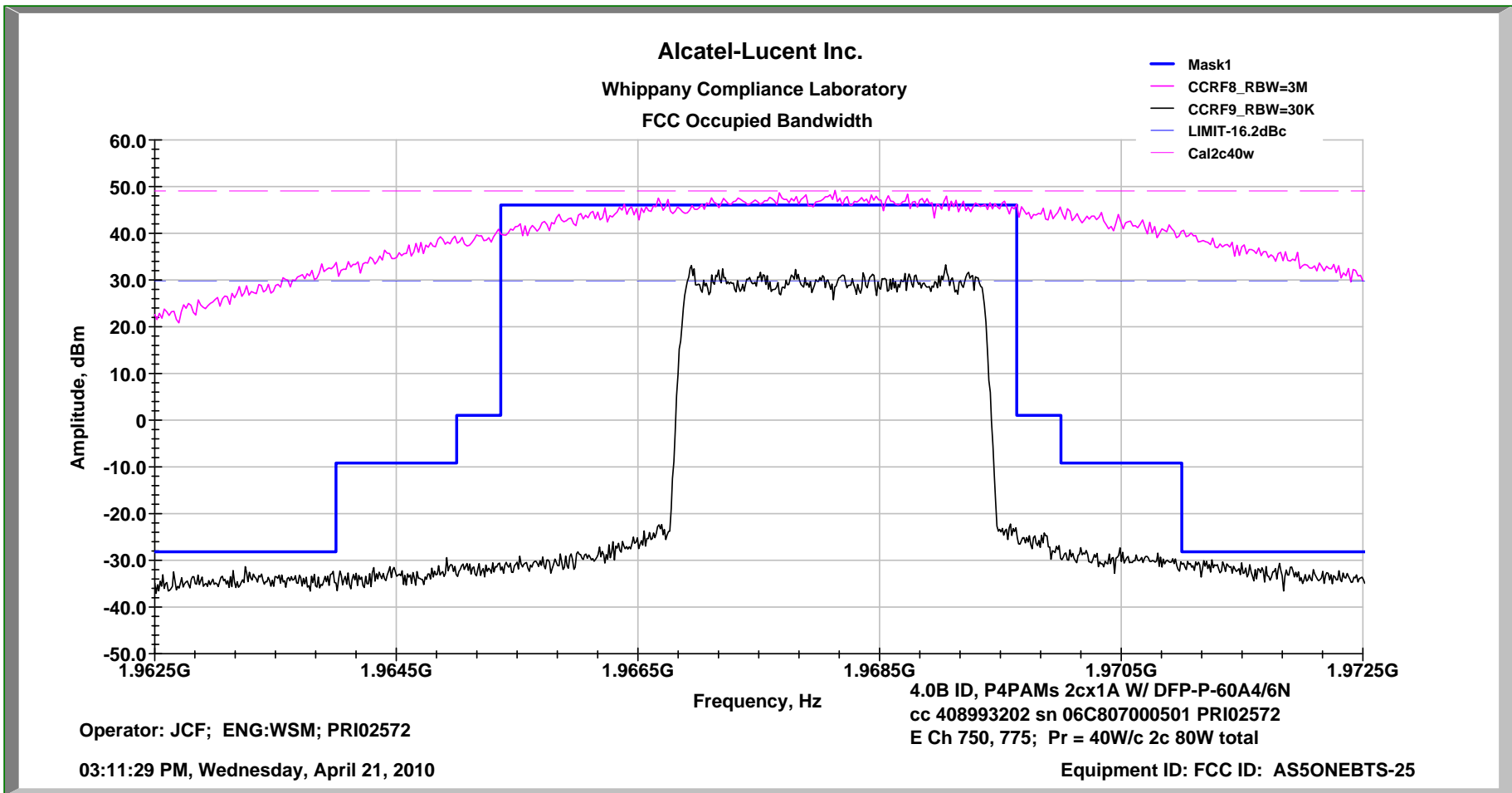
**Occupied Bandwidth PCS Ch EL-725, 750 Andrew P4PAM 2cx1A 40W/c 80W Total**



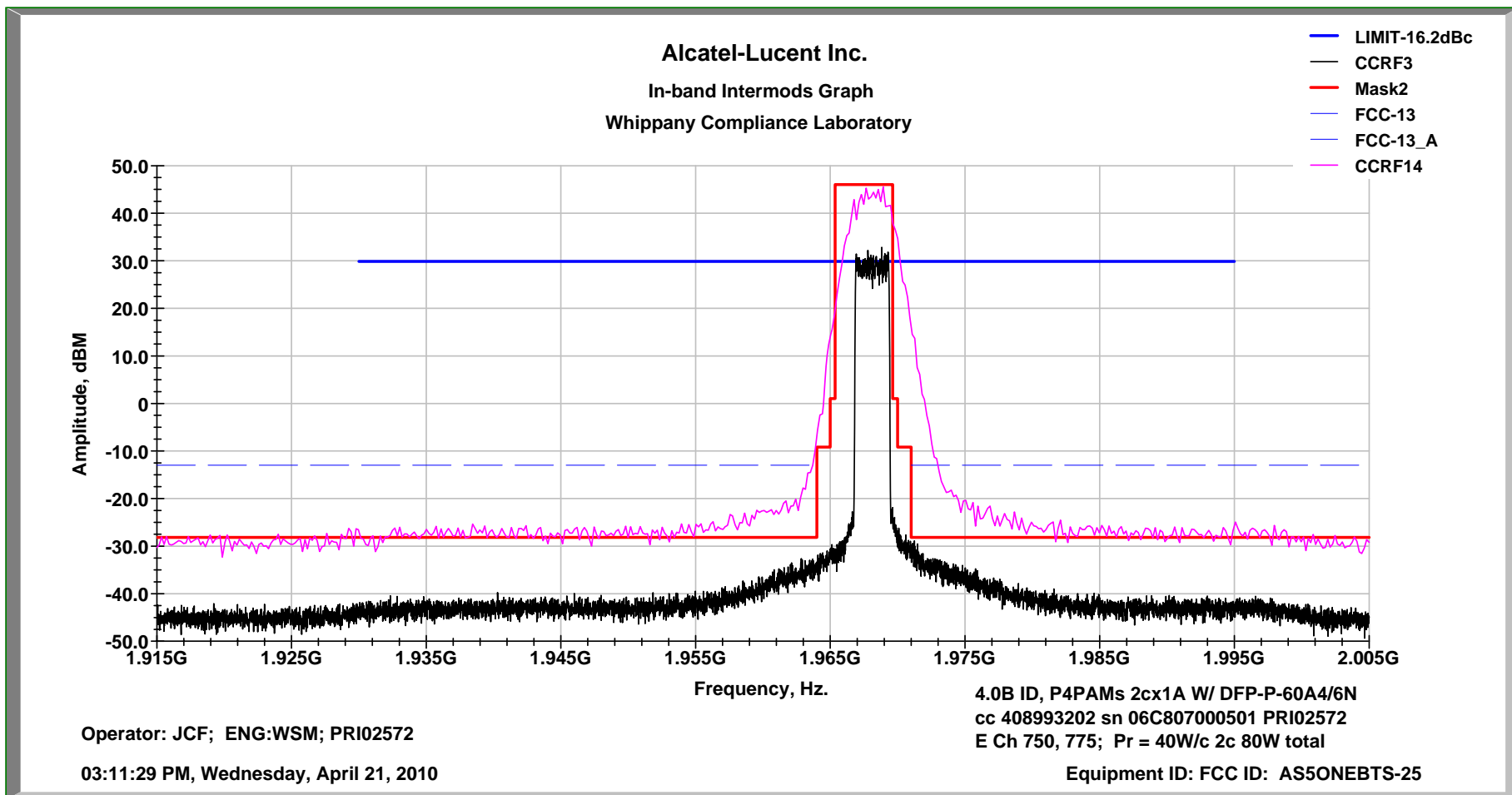
**In-band Inter-modulation    PCS Ch EL-725, 750    Andrew P4PAM 2cx1A 40W/c 80W Total**



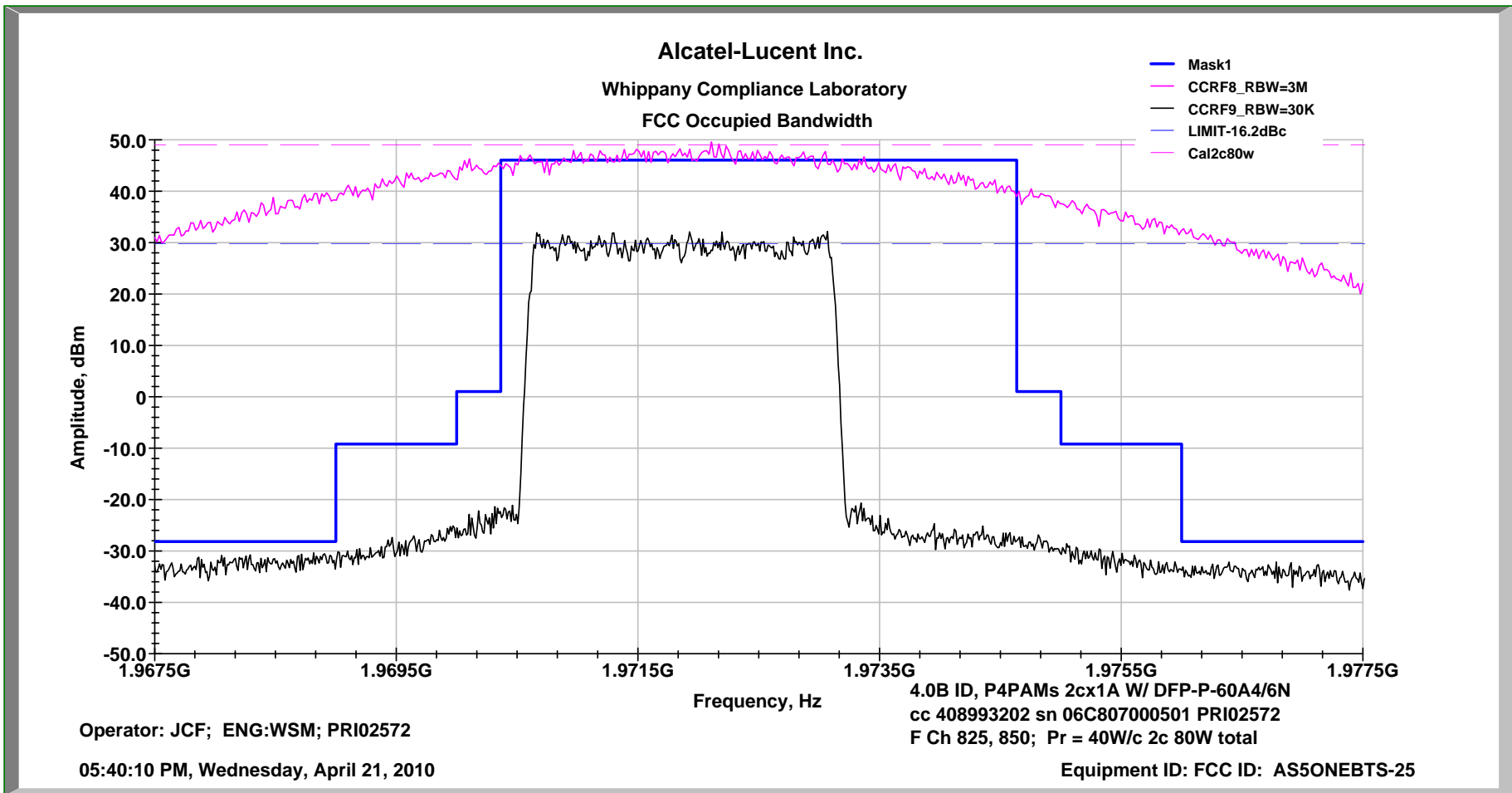
**Occupied Bandwidth PCS Ch ER-750, 775 Andrew P4PAM 2cx1A 40W/c 80W Total**



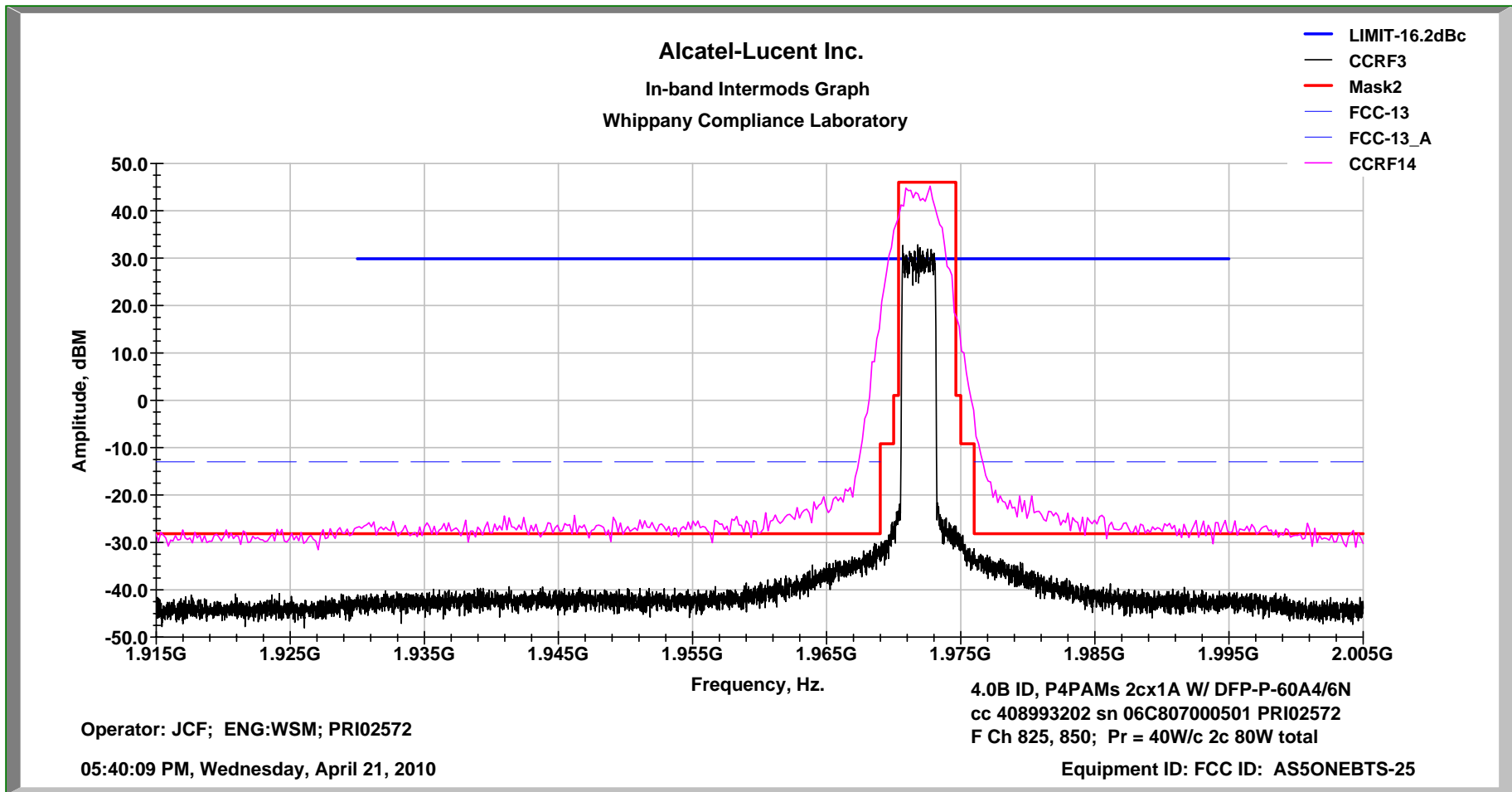
**In-band Inter-modulation    PCS Ch ER-750, 775    Andrew P4PAM 2cx1A    40W/c 80W Total**



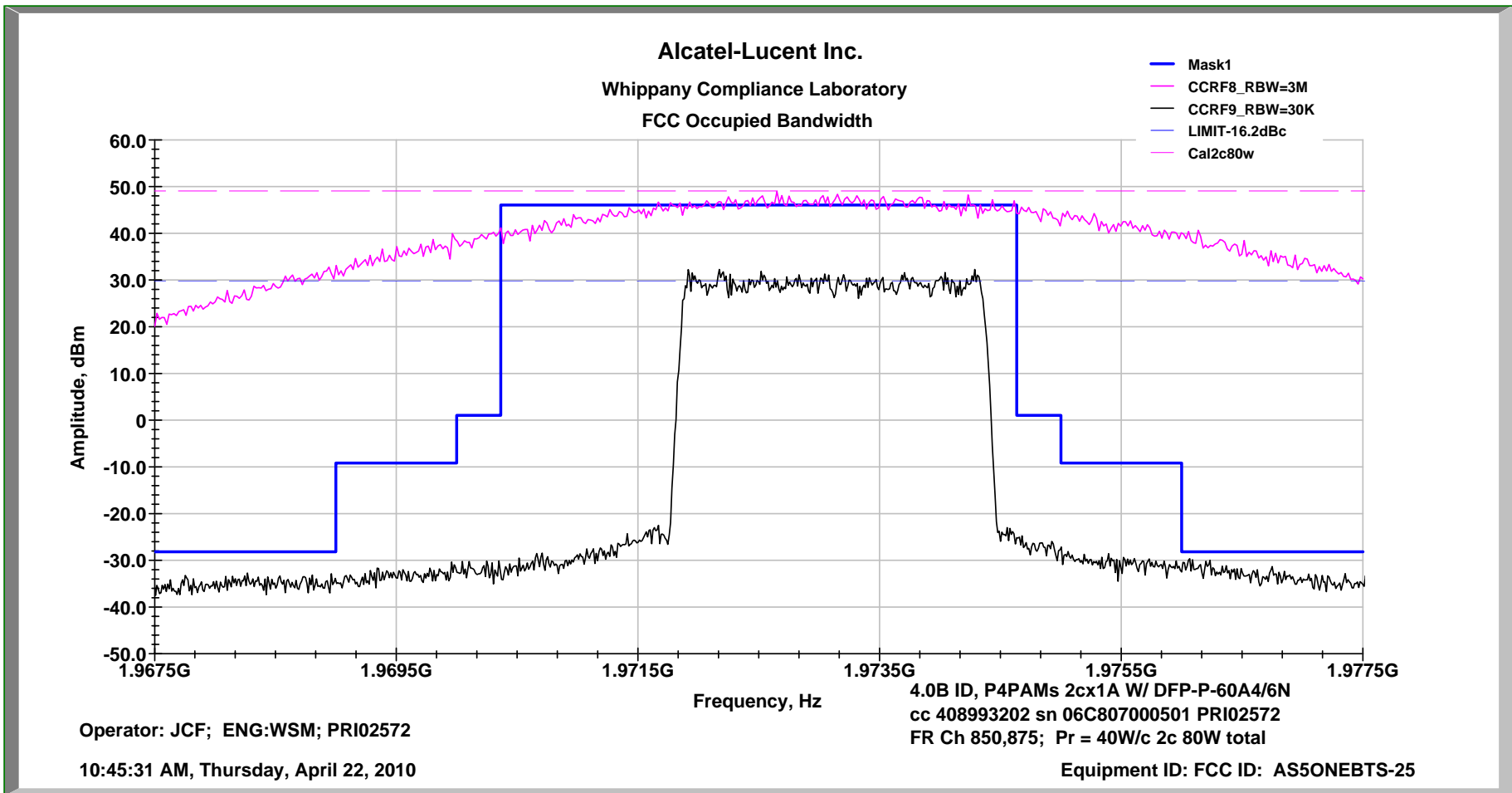
**Occupied Bandwidth PCS Ch FL-825, 850 Andrew P4PAM 2cx1A 40W/c 80W Total**



**In-band Inter-modulation    PCS Ch FL-825, 850    Andrew P4PAM 2cx1A 40W/c 80W Total**

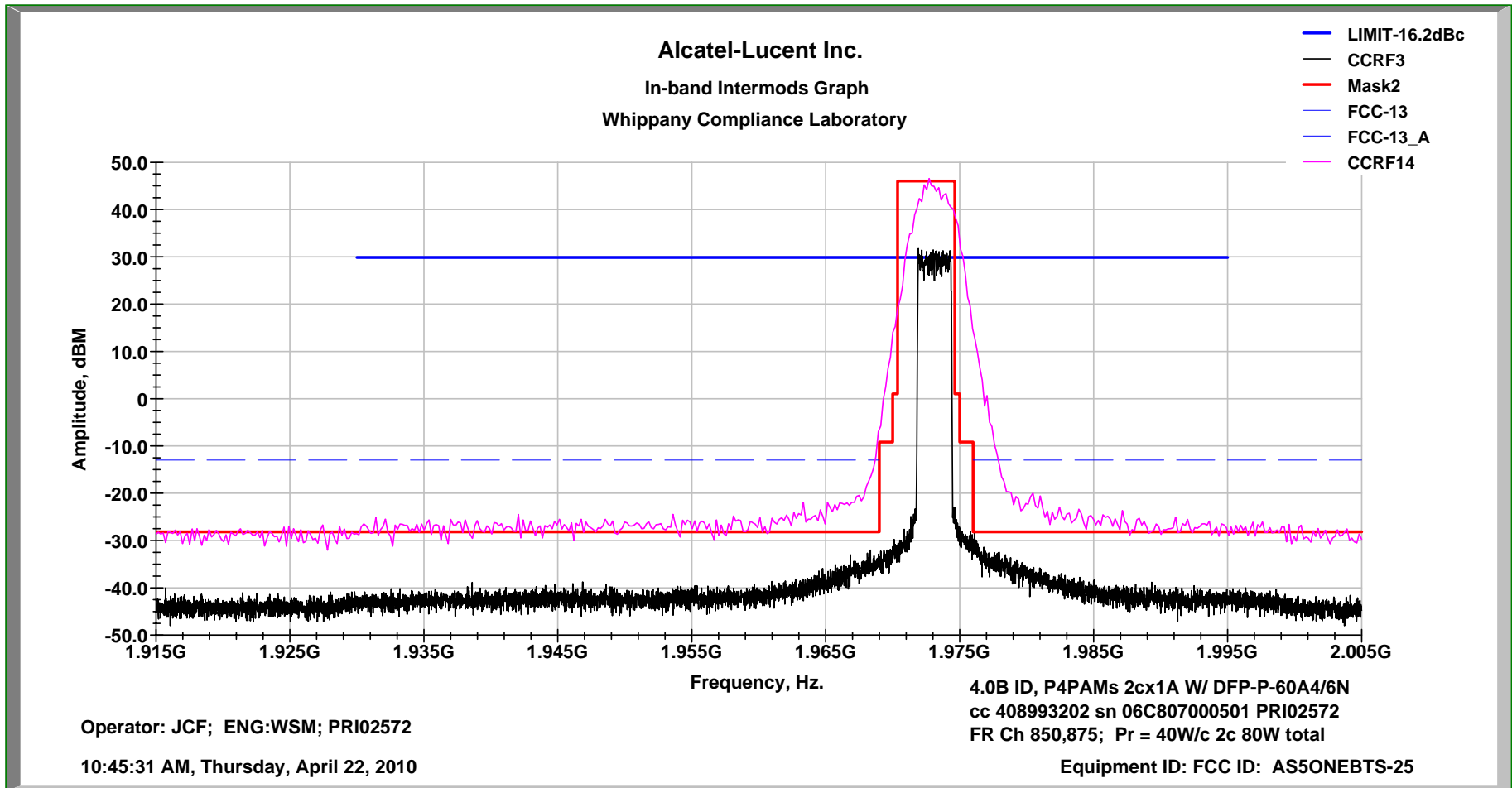


**Occupied Bandwidth PCS Ch FR-850, 875 Andrew P4PAM 2cx1A 40W/c 80W Total**

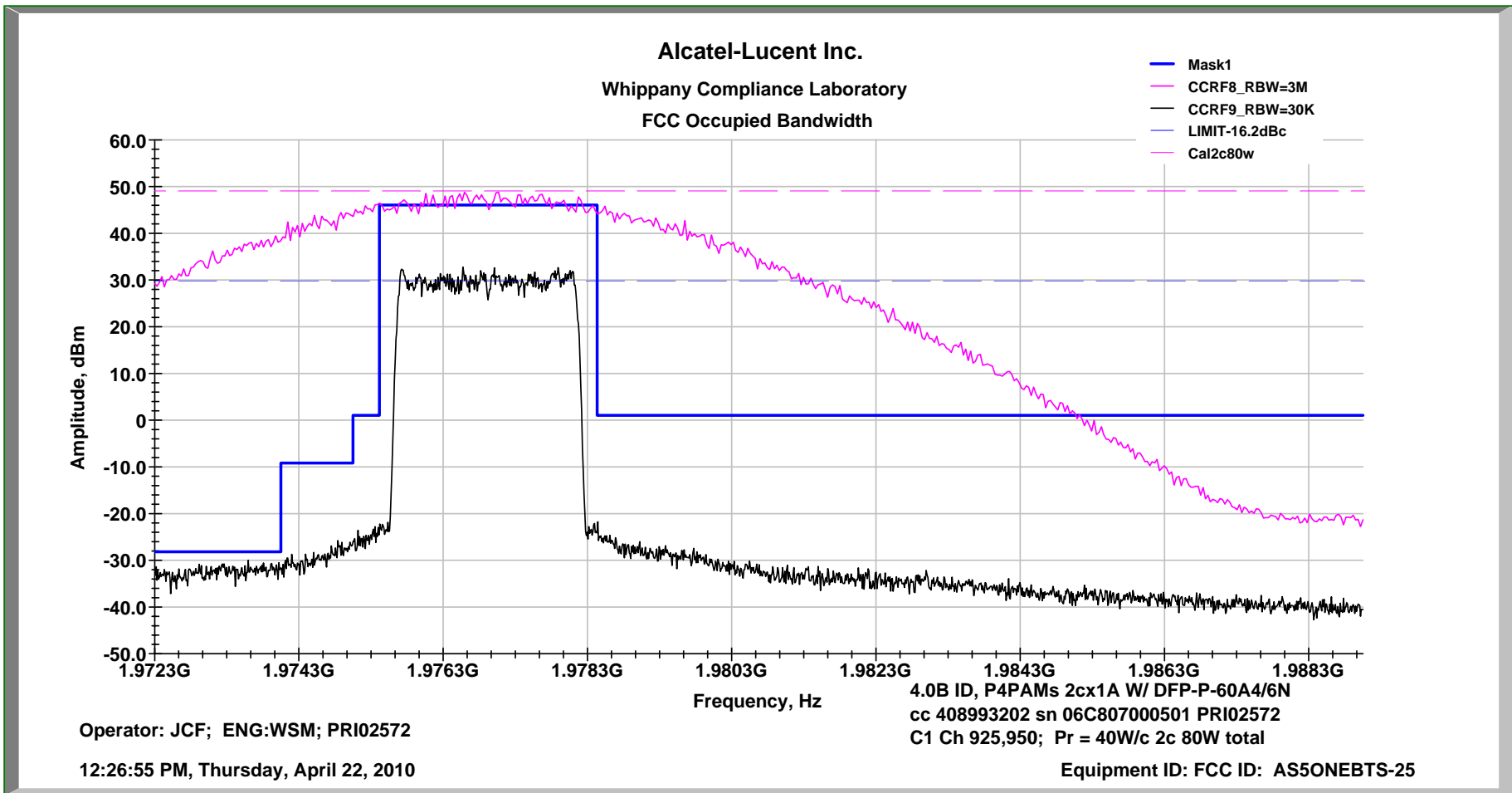




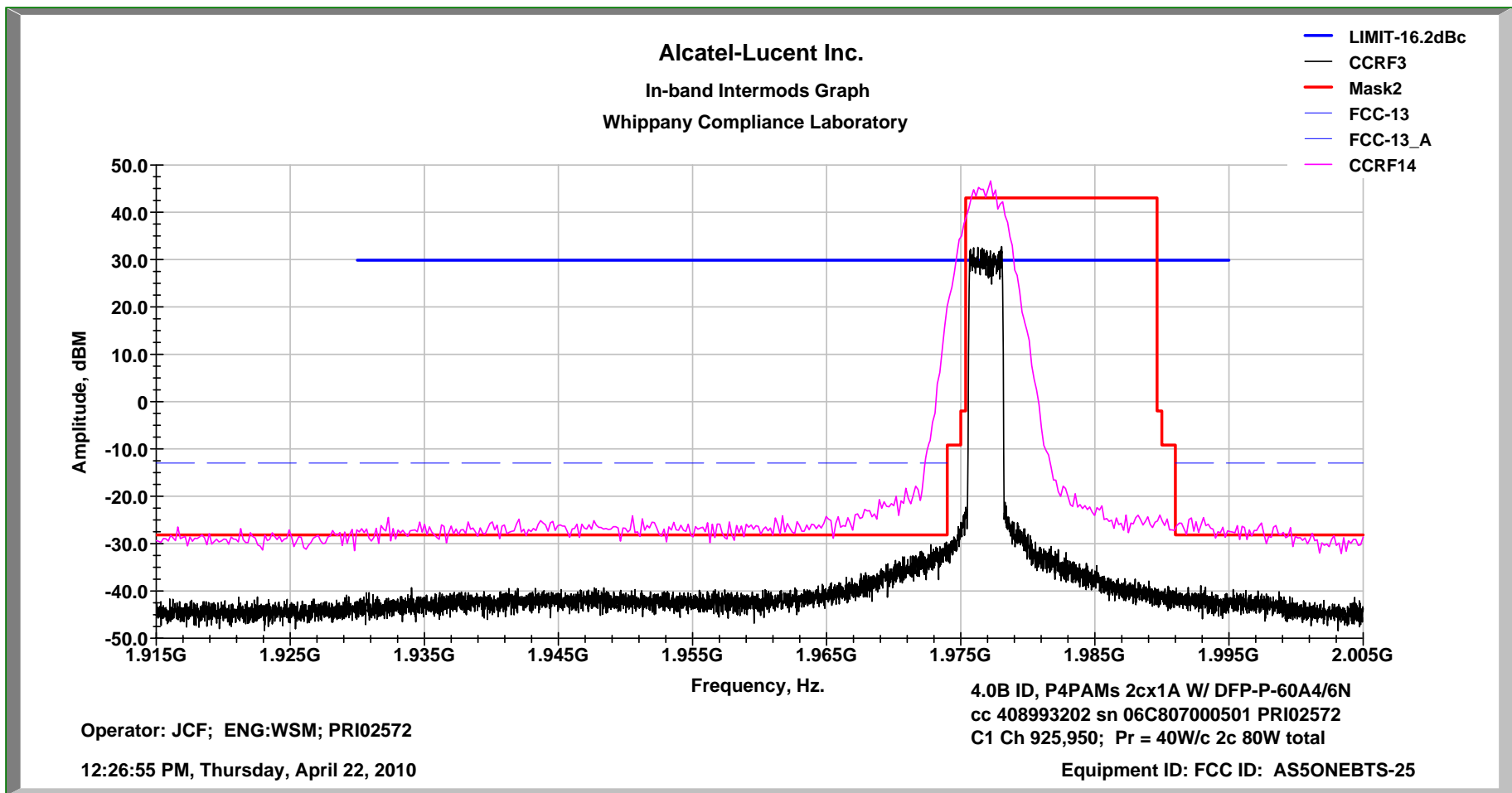
**In-band Inter-modulation    PCS Ch FR-850, 875    Andrew P4PAM 2cx1A 40W/c 80W Total**



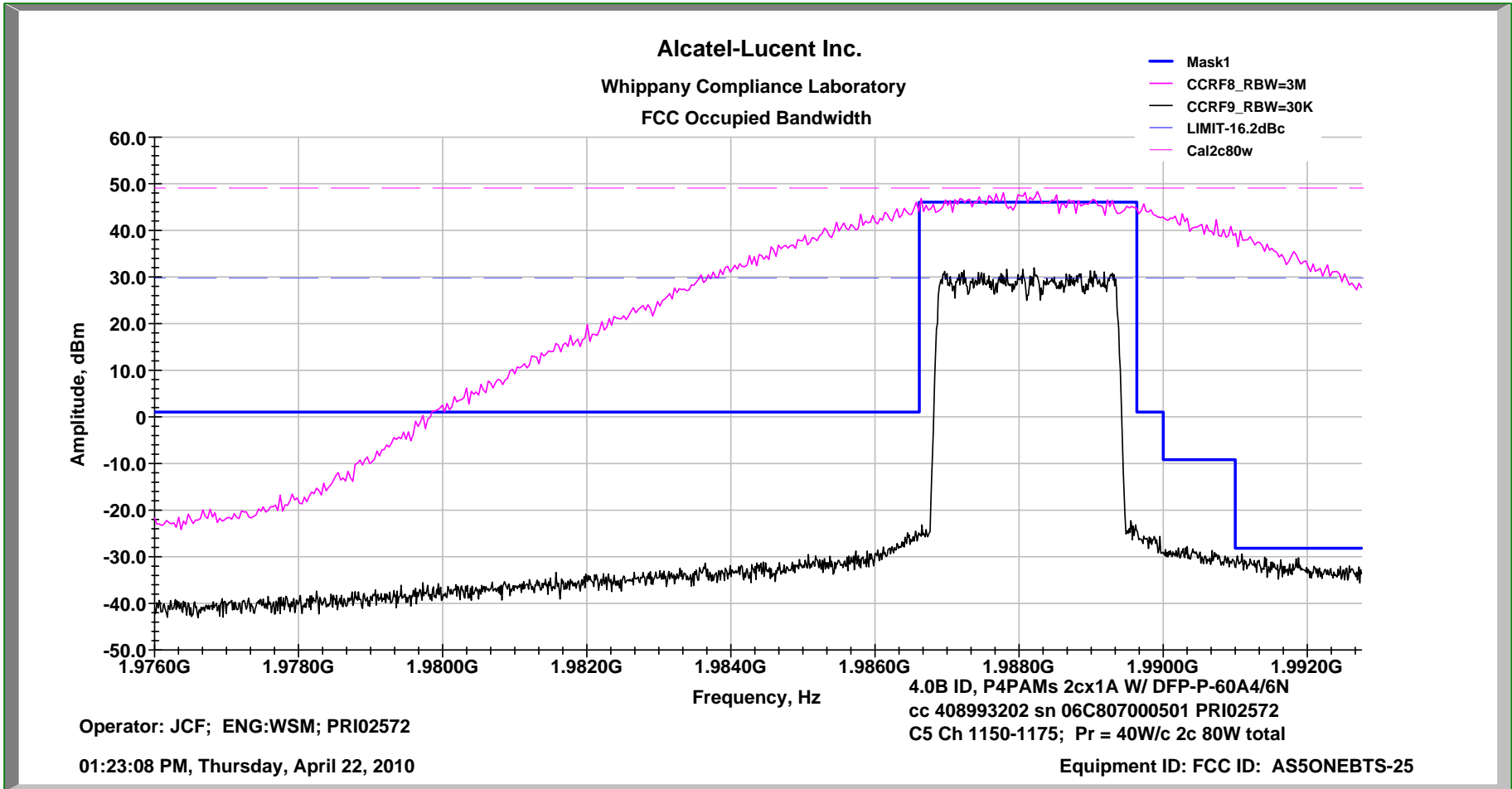
**Occupied Bandwidth PCS Ch C1-925, 950 Andrew P4PAM 2cx1A 40W/c 80W Total**



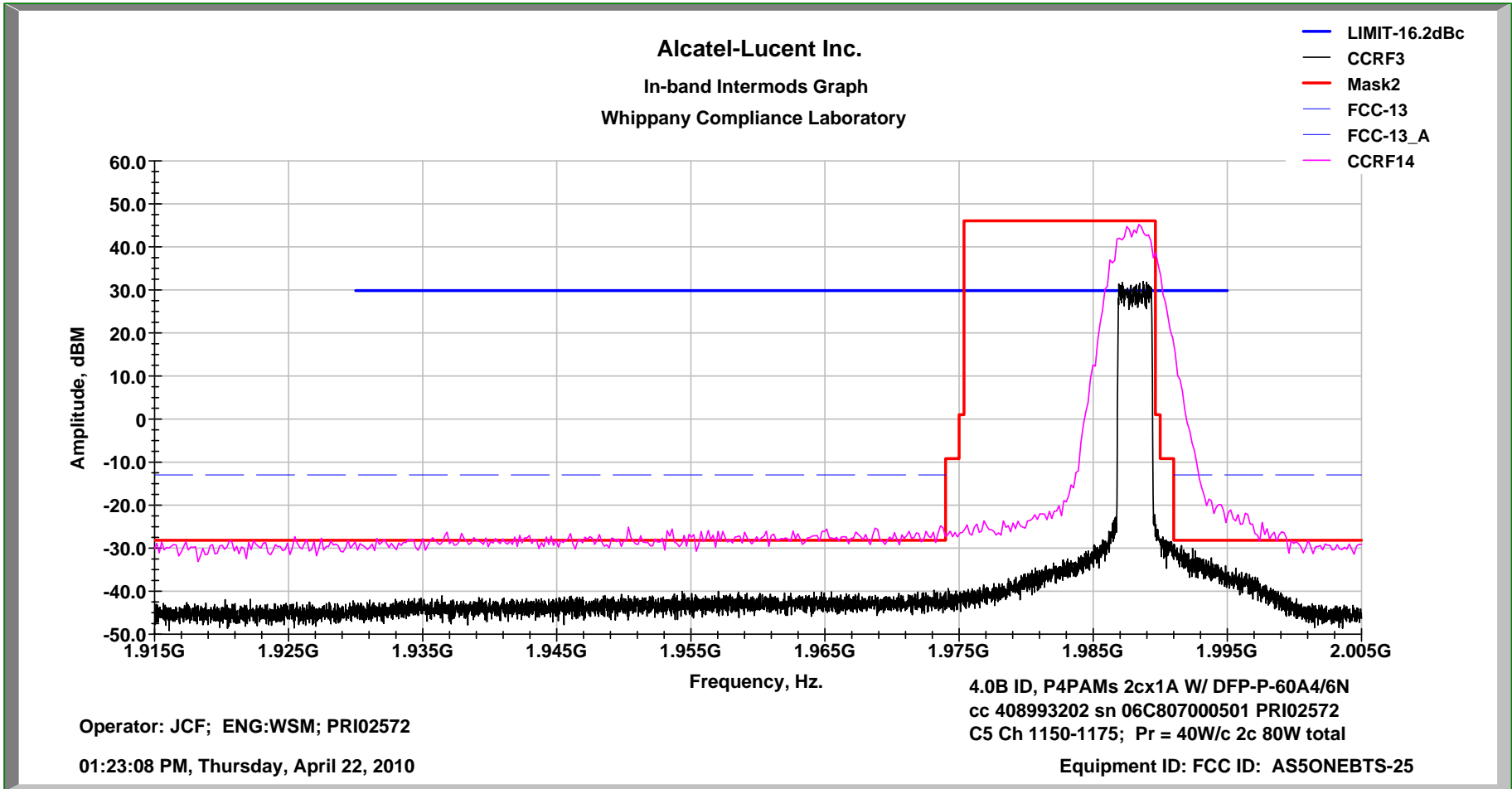
**In-band Inter-modulation    PCS Ch C1-925, 950    Andrew P4PAM 2cx1A 40W/c 80W Total**



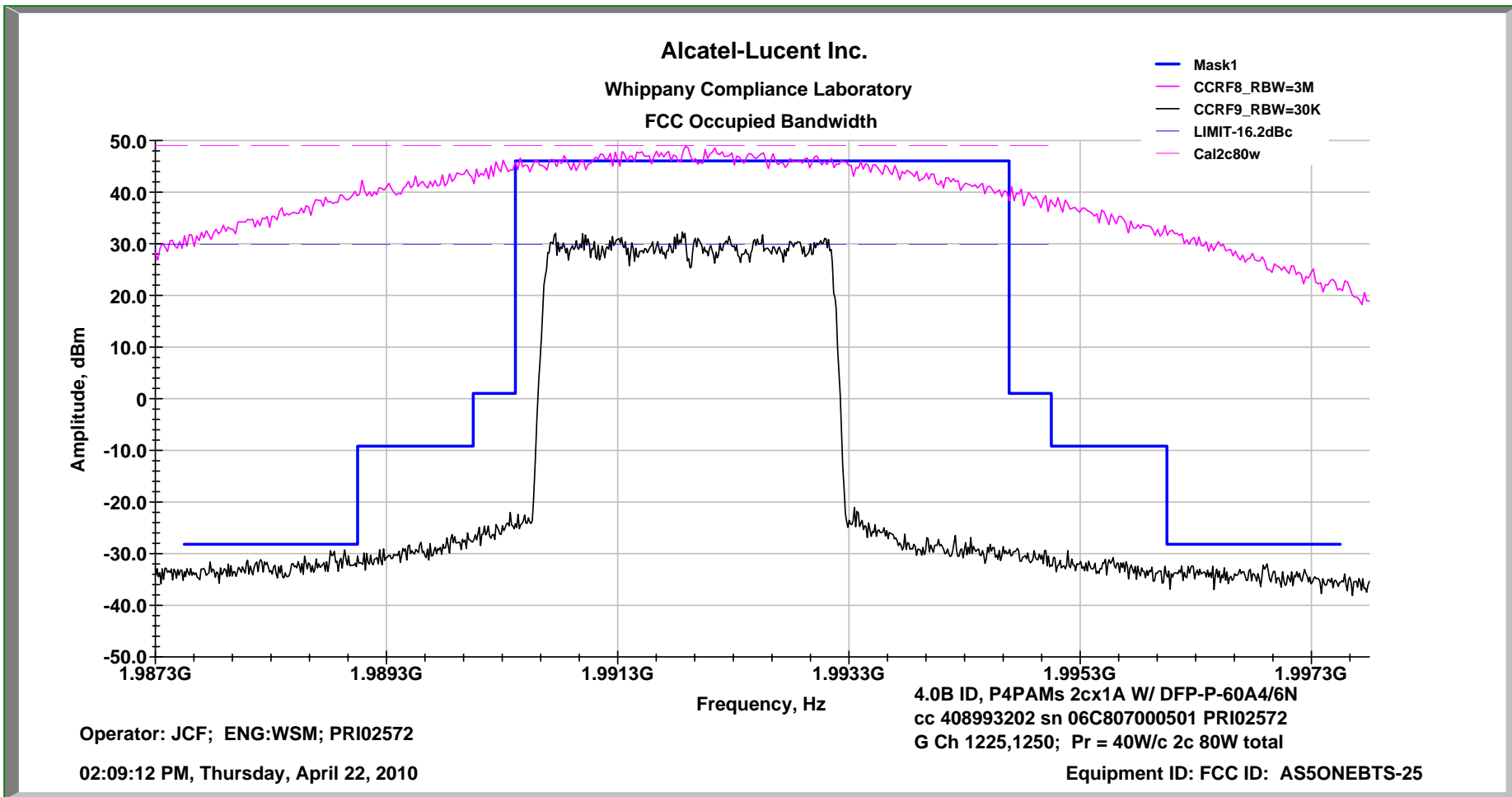
**Occupied Bandwidth PCS Ch C5-1150, 1175 Andrew P4PAM 2cx1A 40W/c 80W Total**



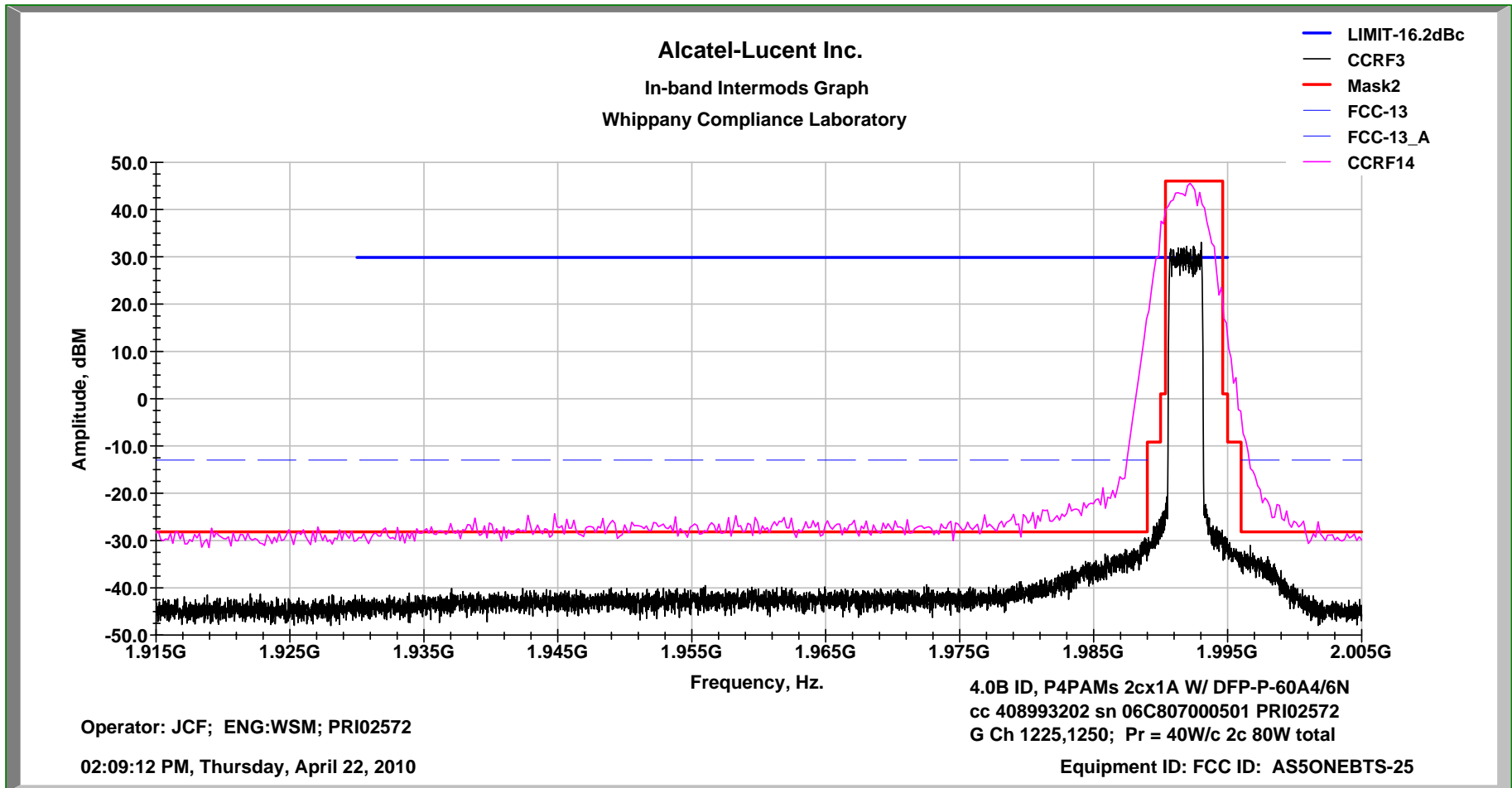
**In-band Inter-modulation    PCS Ch B1-425-500    Andrew P4PAM 2cx1A 40W/c 80W Total**



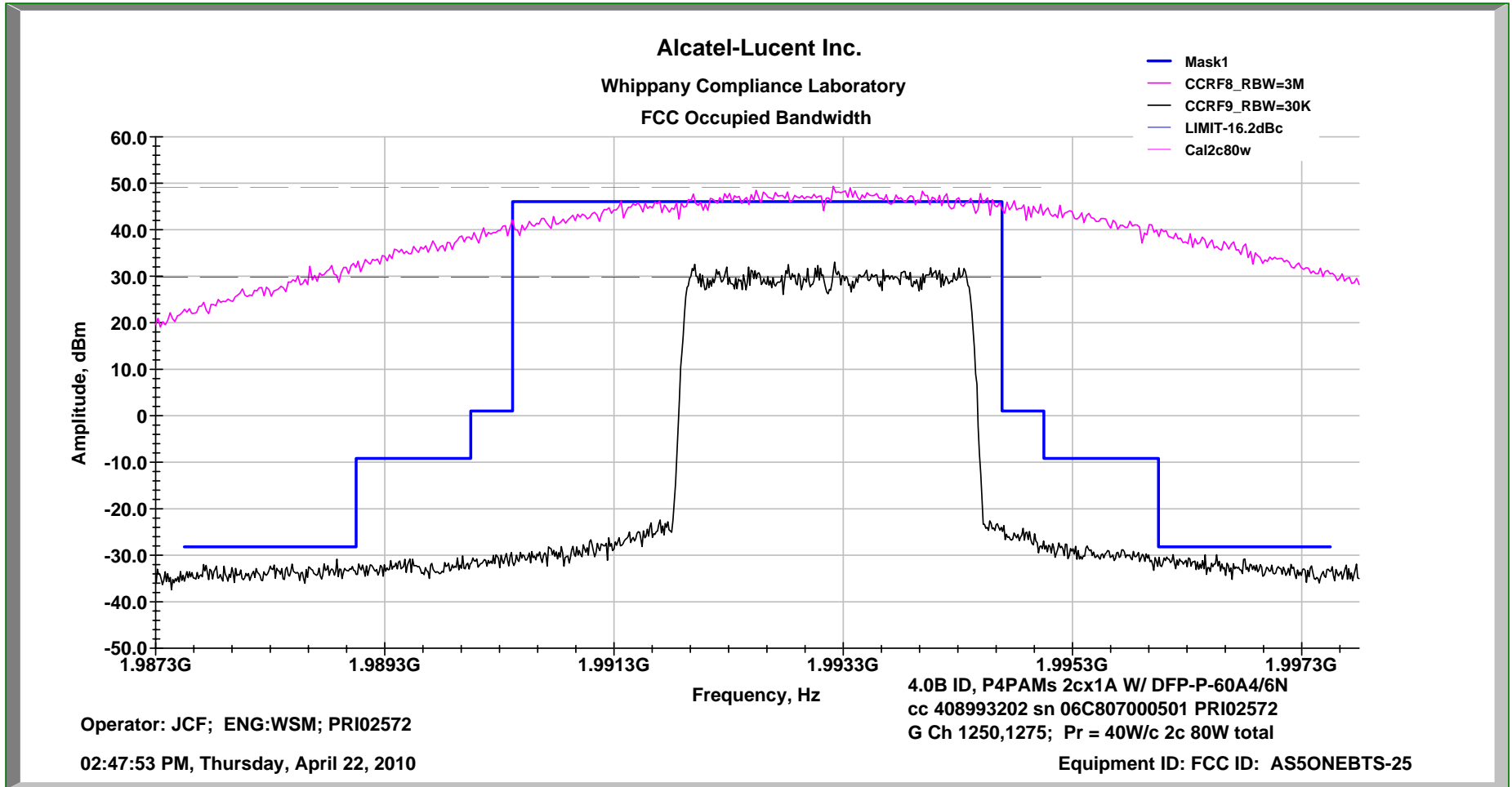
### Occupied Bandwidth PCS Ch GL-1225, 1250 Andrew P4PAM 2cx1A 40W/c 80W Total



**In-band Inter-modulation      PCS Ch GR-1225, 1250 Andrew P4PAM 2cx1A 40W/c 80W Total**

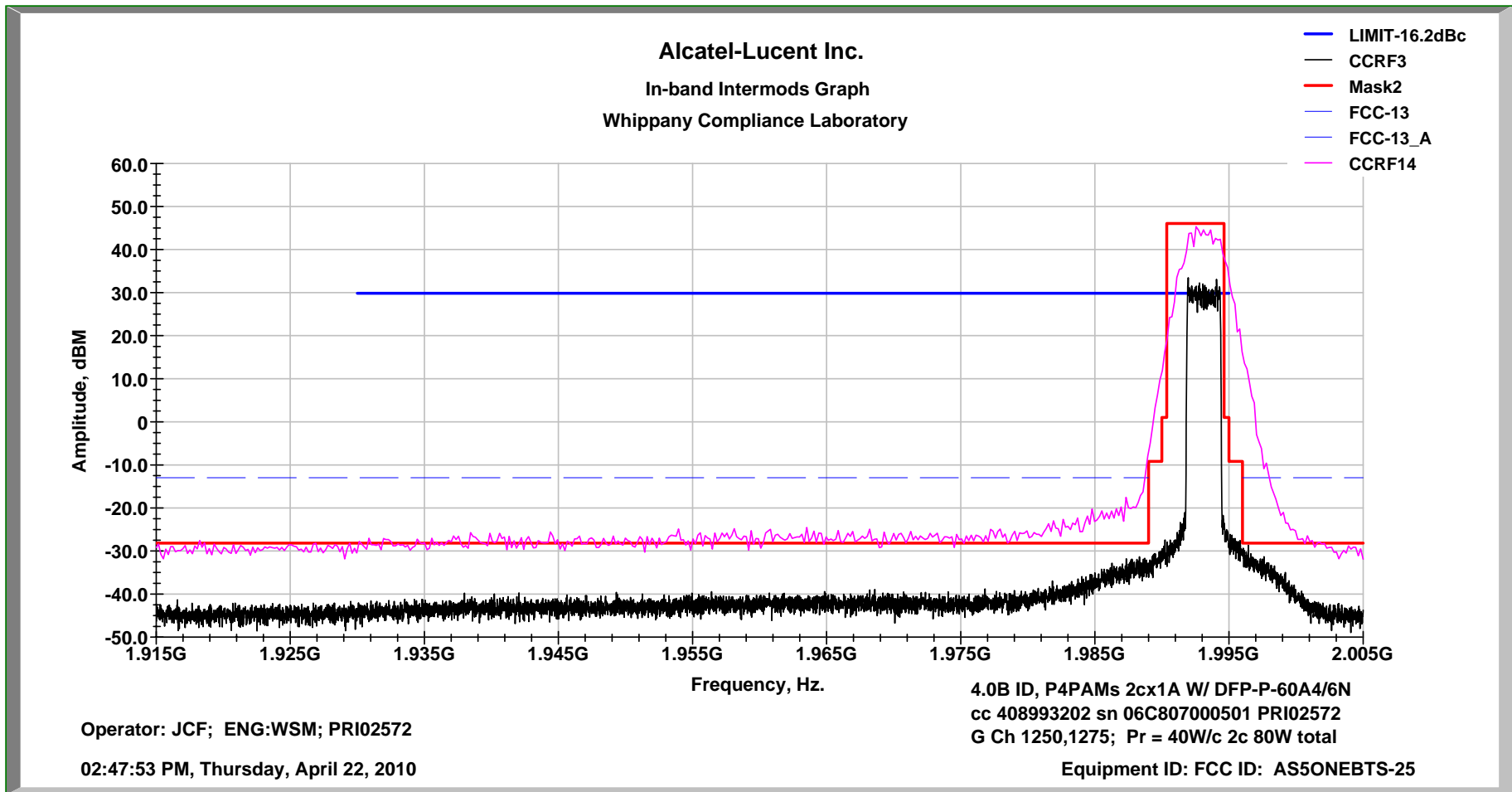


### Occupied Bandwidth PCS Ch GR-1250, 1275 Andrew P4PAM 2cx1A 40W/c 80W Total





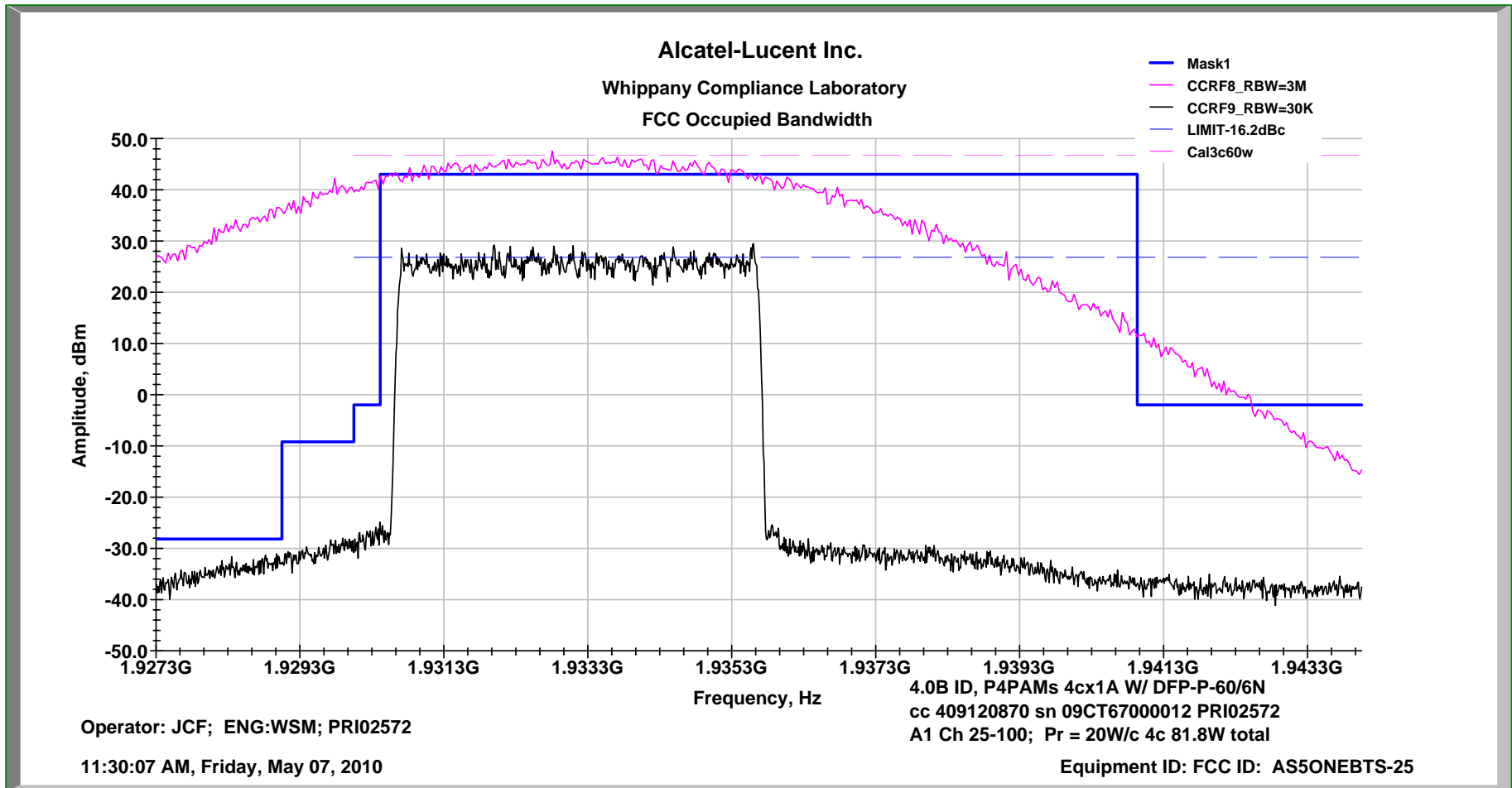
**In-band Inter-modulation      PCS Ch GR-1250, 1275 Andrew P4PAM 2cx1A 40W/c 80W Total**



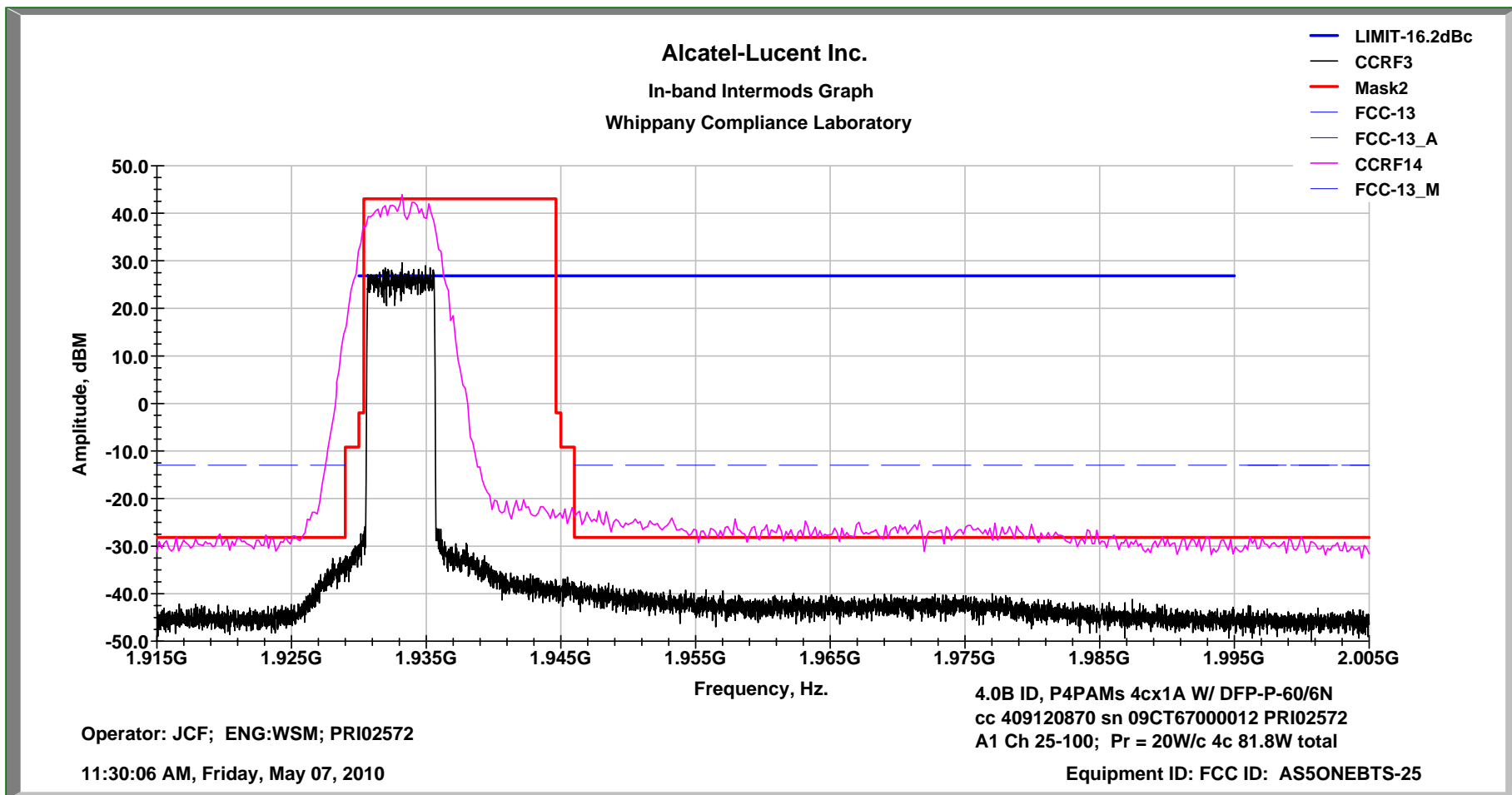
**Single Amplifier Four Carrier  
80 W/Amp 80W Total  
Occupied Bandwidth Data  
PCS Blocks A through G  
Left side of Block, Right side of Block  
And  
PCS Band Intermodulation**

**4c x 1A 20W/c**

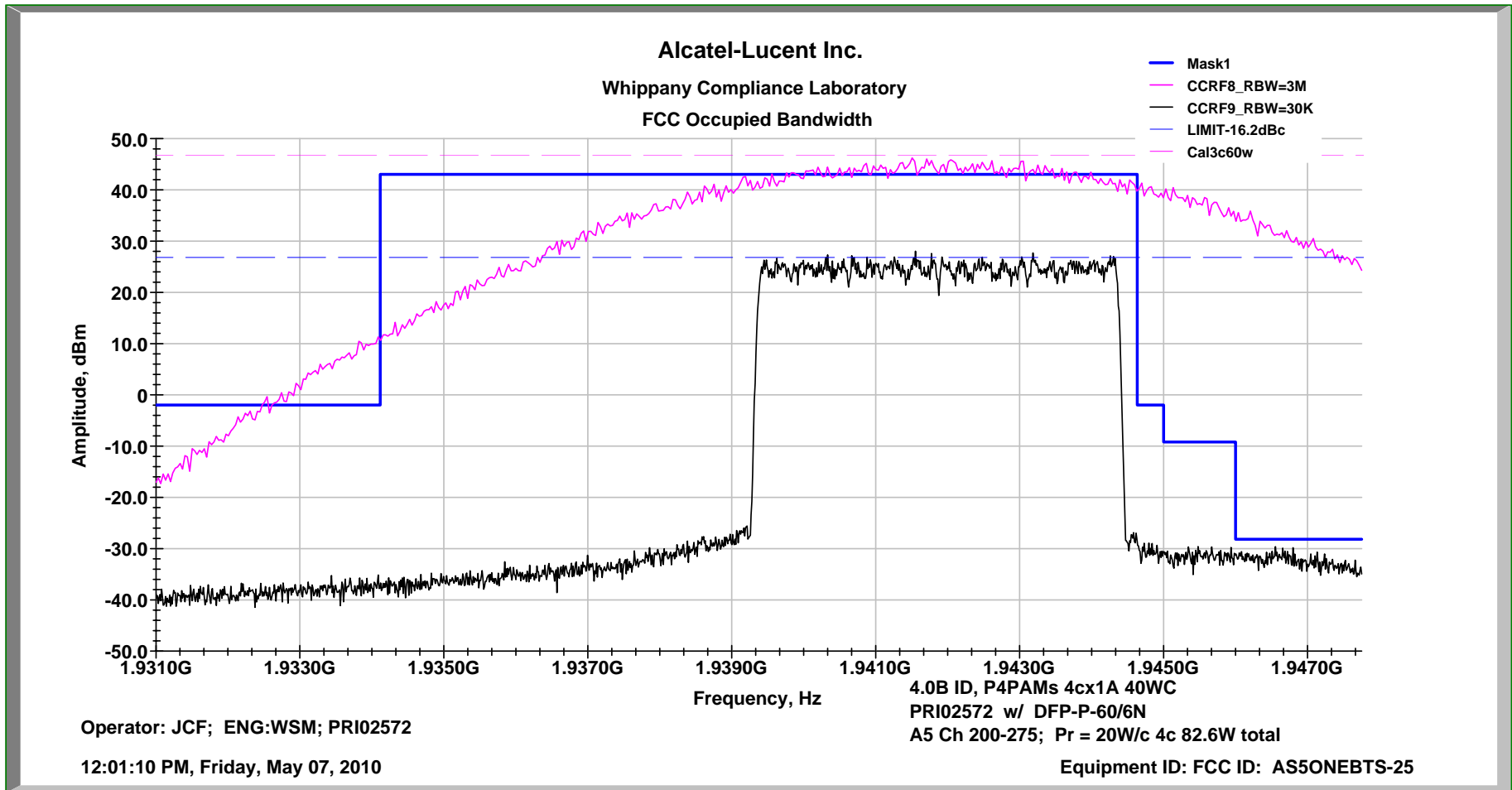
**Occupied Bandwidth PCS Ch A1-25-100 Andrew P4PAM 4cx1A 20W/c 80W Total**



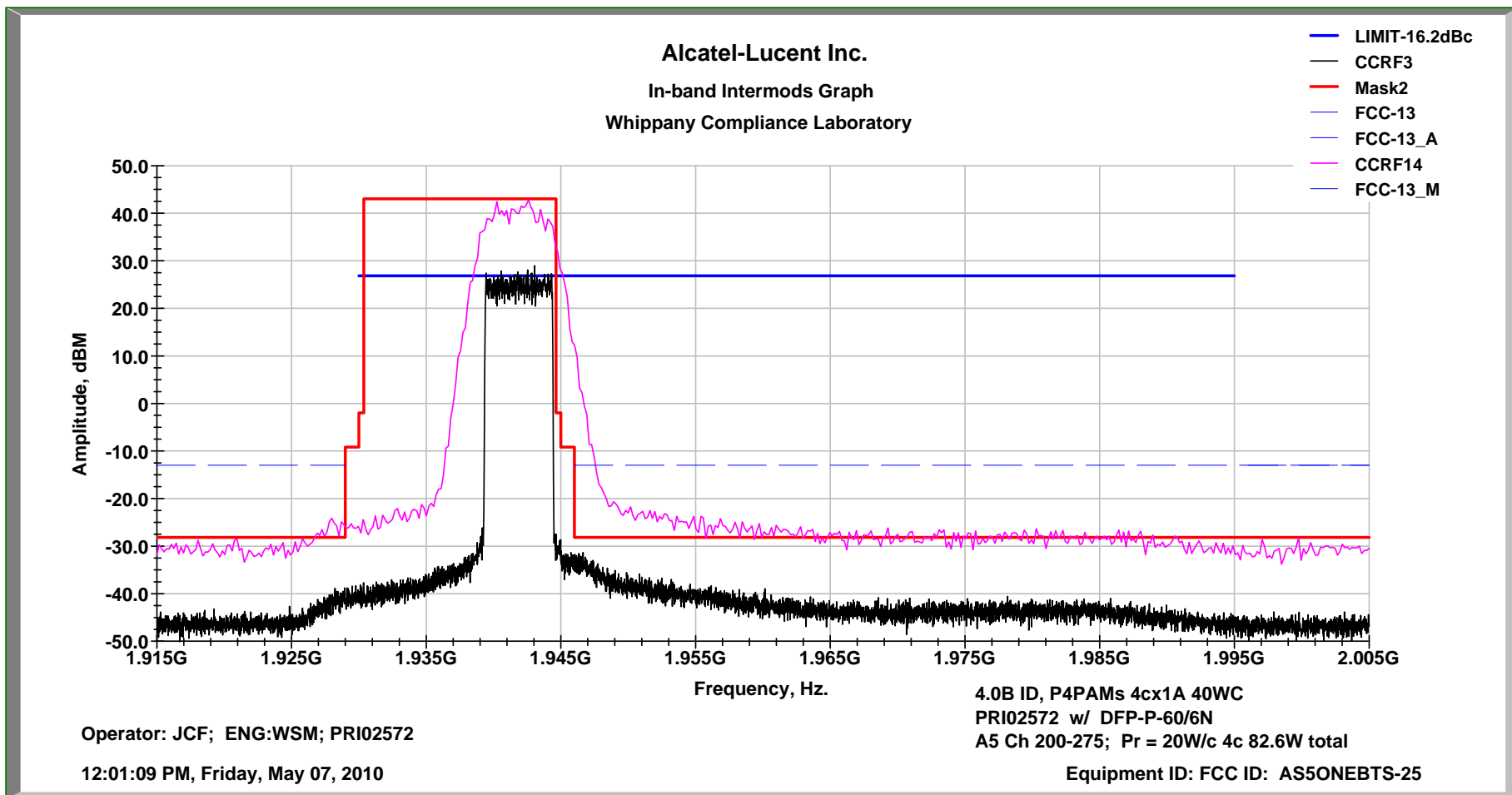
**In-band Inter-modulation    PCS Ch A1-25-100    Andrew P4PAM 4cx1A 20W/c 80W Total**



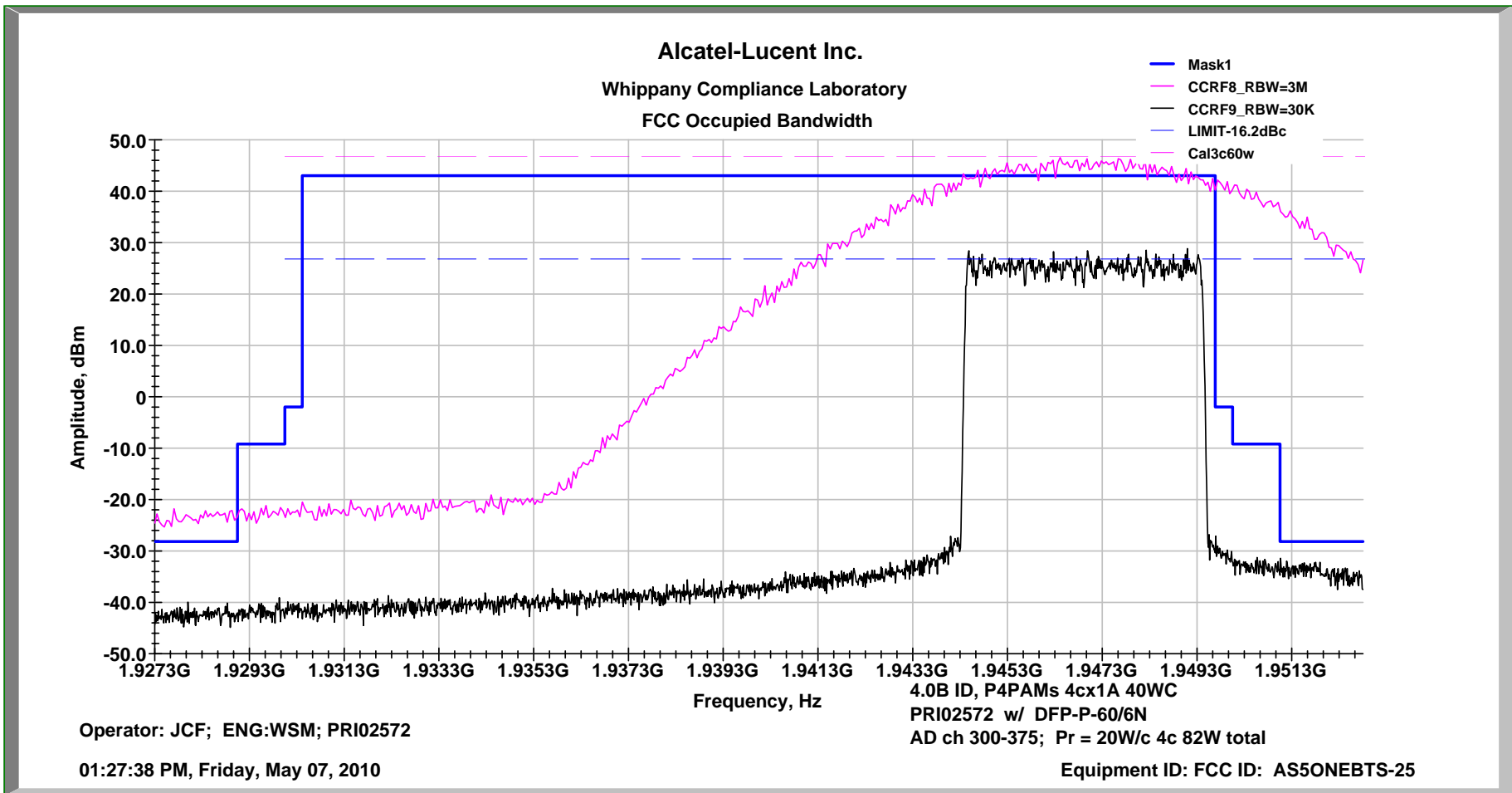
**Occupied Bandwidth PCS Ch A5-200-275 Andrew P4PAM 4cx1A 20W/c 80W Total**



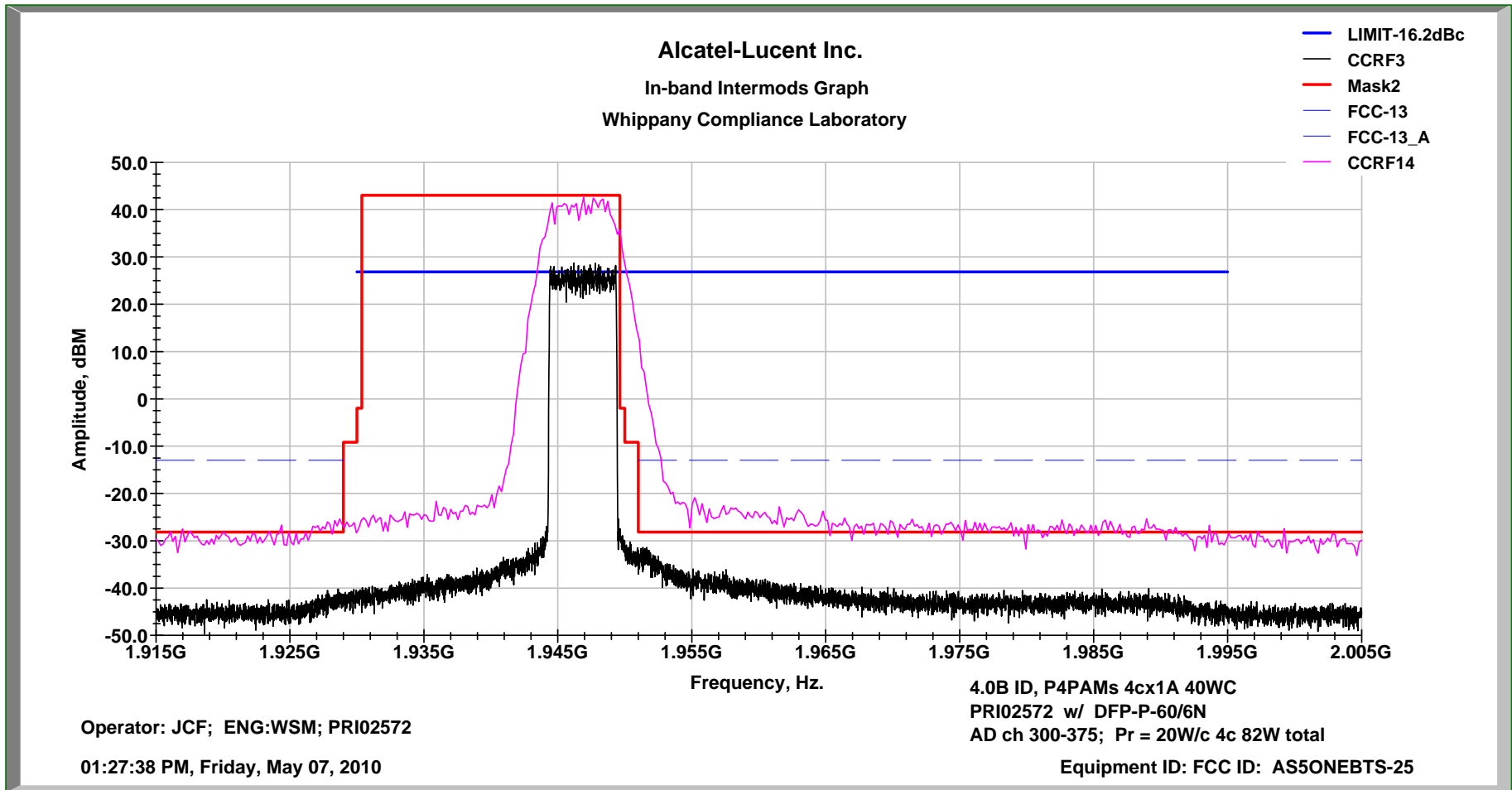
**In-band Inter-modulation    PCS Ch A5-200-275    Andrew P4PAM 4cx1A 20W/c 80W Total**



**Occupied Bandwidth PCS Ch AD-300-375 Andrew P4PAM 4cx1A 20W/c 80W Total**

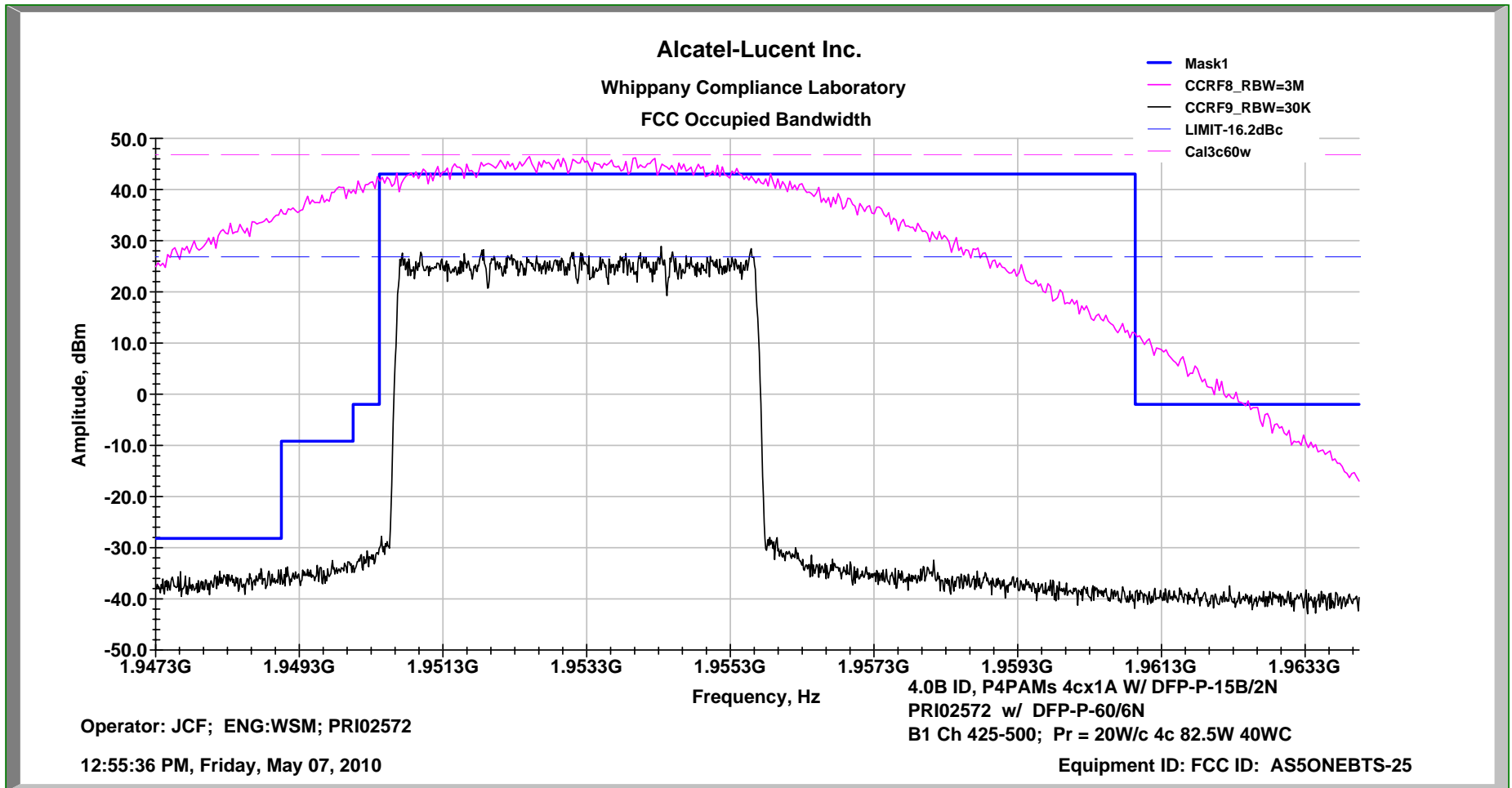


**In-band Inter-modulation    PCS Ch AD-300-375    Andrew P4PAM 4cx1A 20W/c 80W Total**

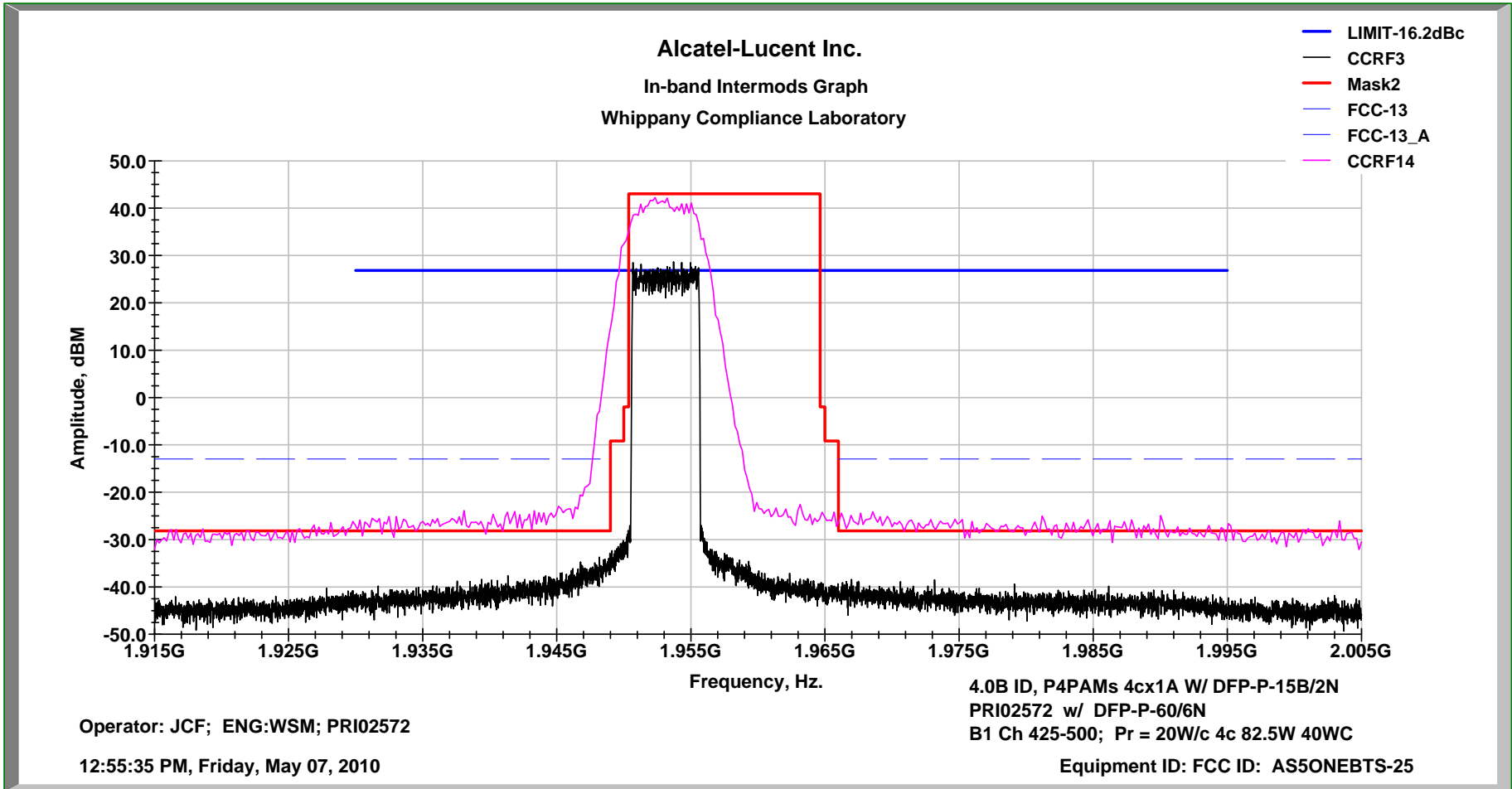




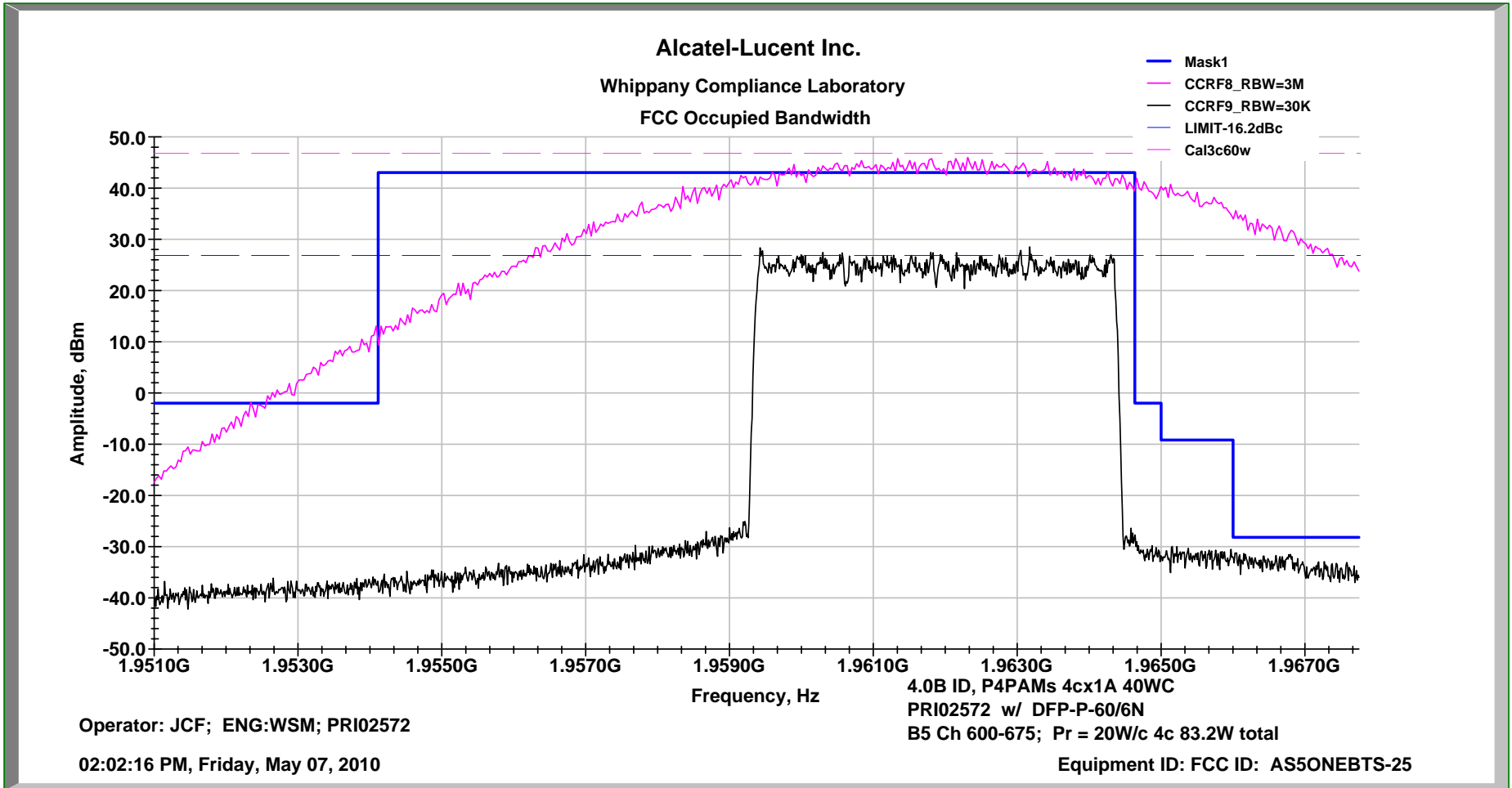
**Occupied Bandwidth PCS Ch B1-425-500 Andrew P4PAM 4cx1A 20W/c 80W Total**



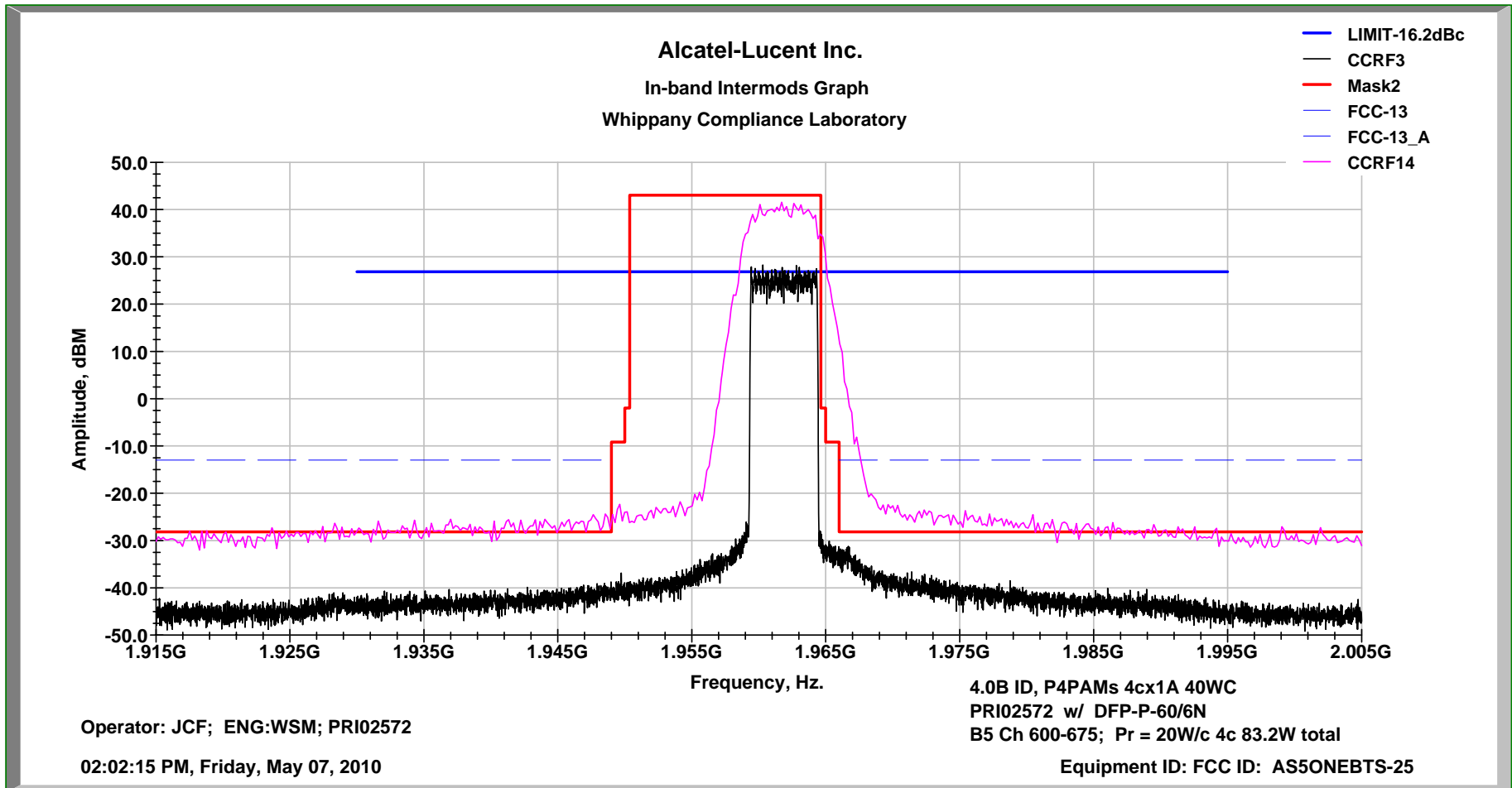
**In-band Inter-modulation    PCS Ch B1-425-500    Andrew P4PAM 4cx1A 20W/c 80W Total**



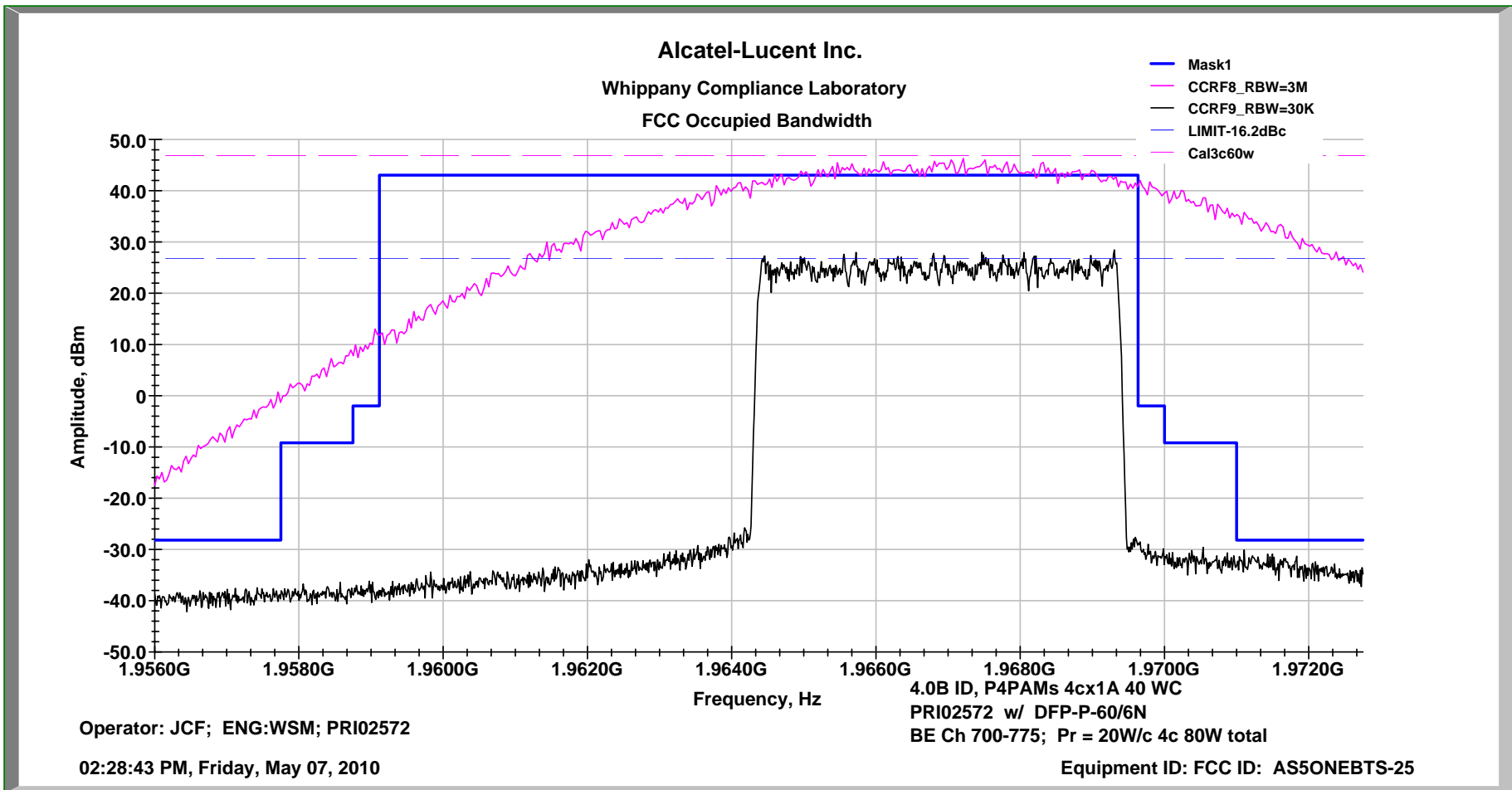
**Occupied Bandwidth PCS Ch B5-600 - 675 Andrew P4PAM 4cx1A 80W Total**



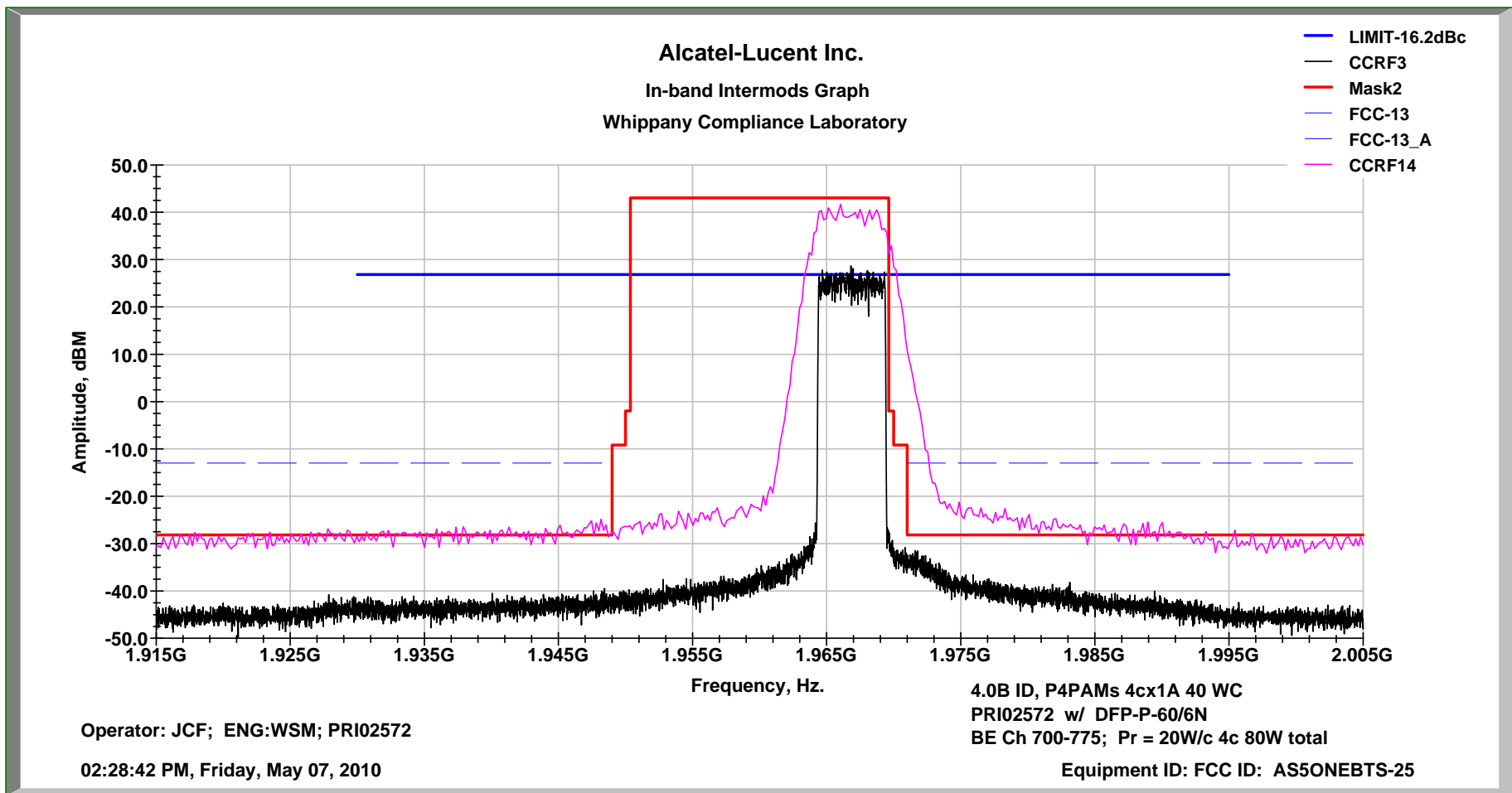
**In-band Inter-modulation    PCS Ch B5-600 - 675    Andrew P4PAM 4cx1A    80W Total**



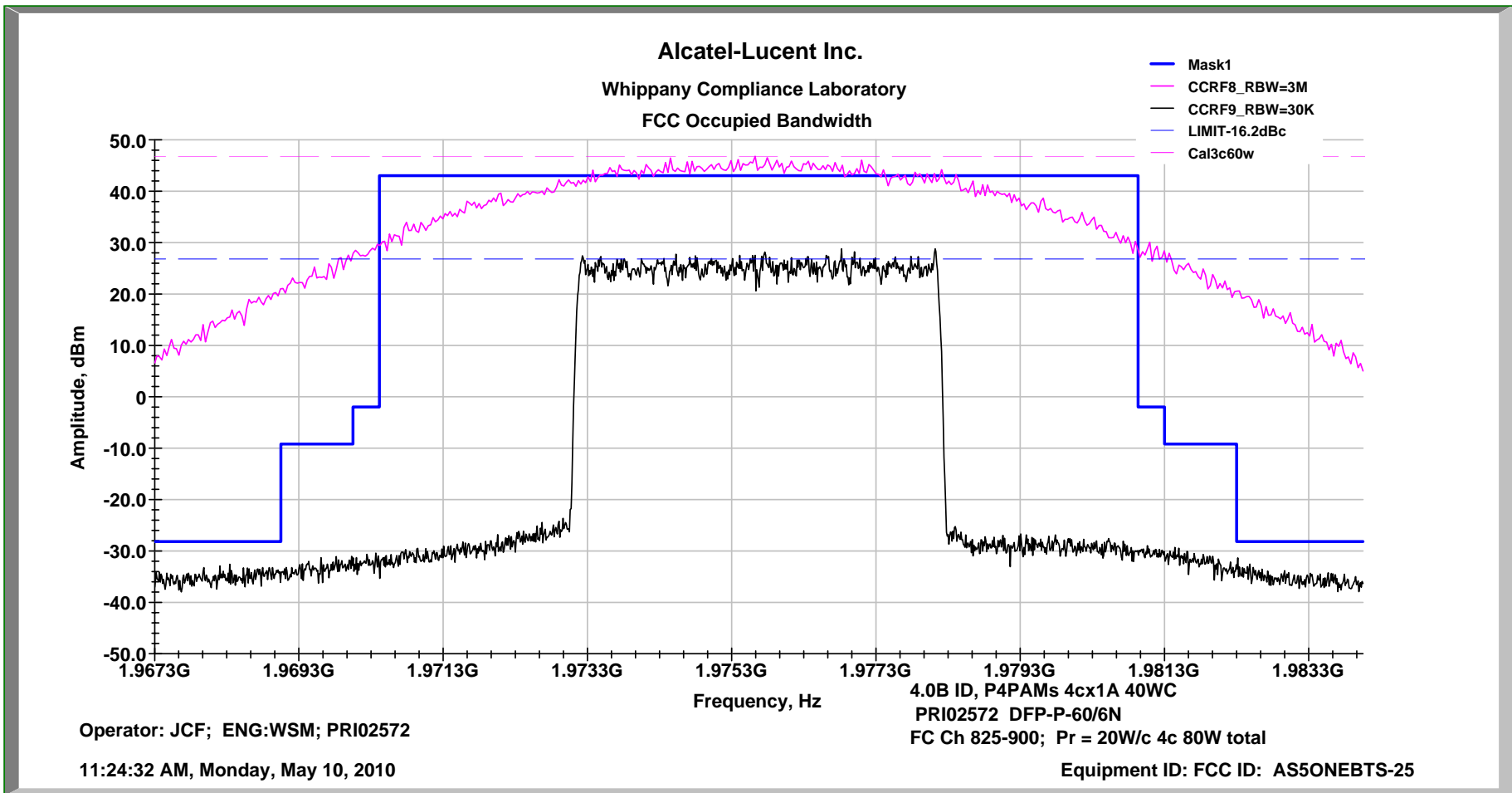
**Occupied Bandwidth PCS Ch BE-700- 775 Andrew P4PAM 4cx1A 80W Total**



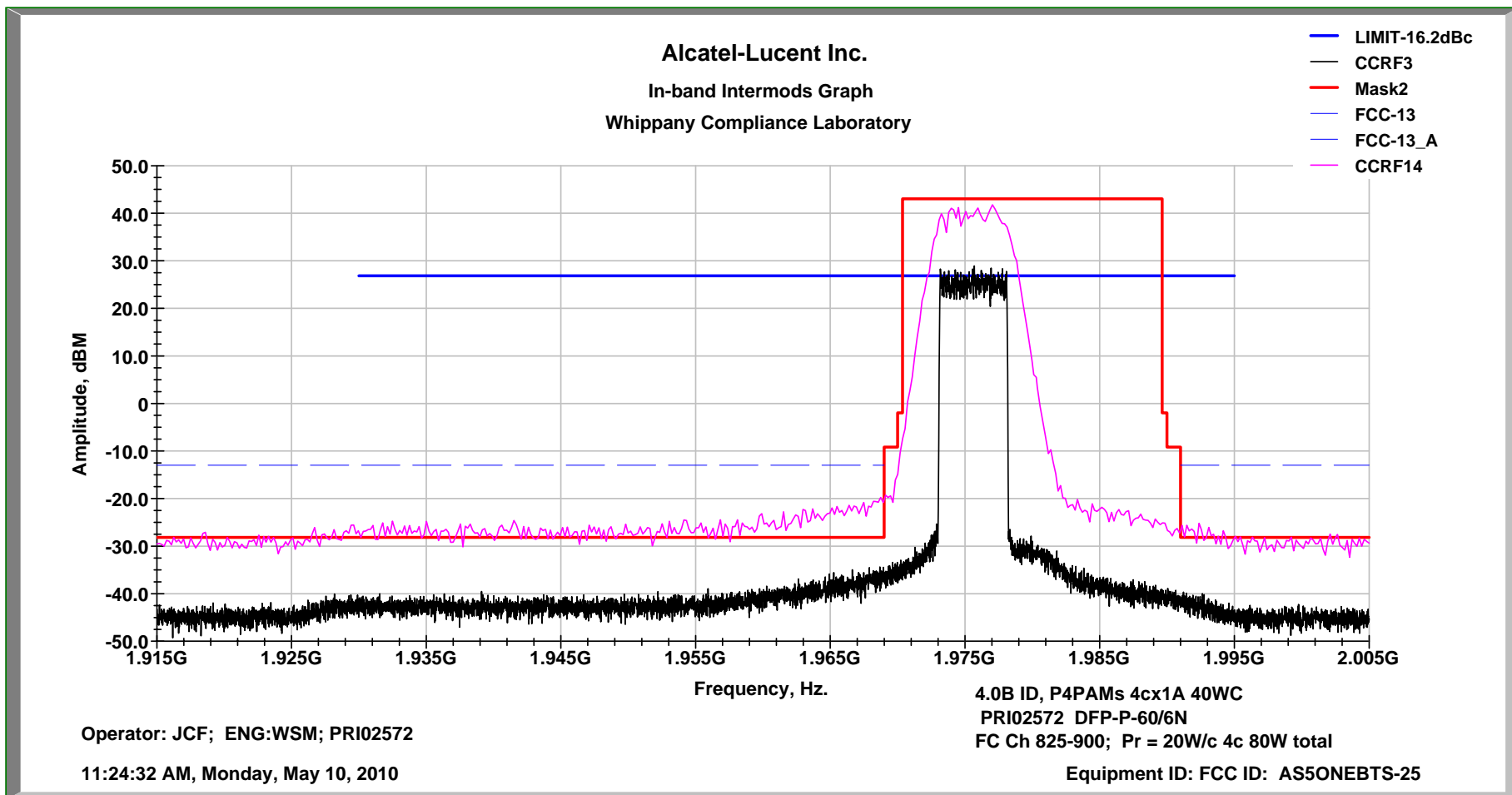
**In-band Inter-modulation    PCS Ch BE-700- 775    Andrew P4PAM 4cx1A    80W Total**



**Occupied Bandwidth PCS Ch FC-825-900 Andrew P4PAM 4cx1A 80W Total**

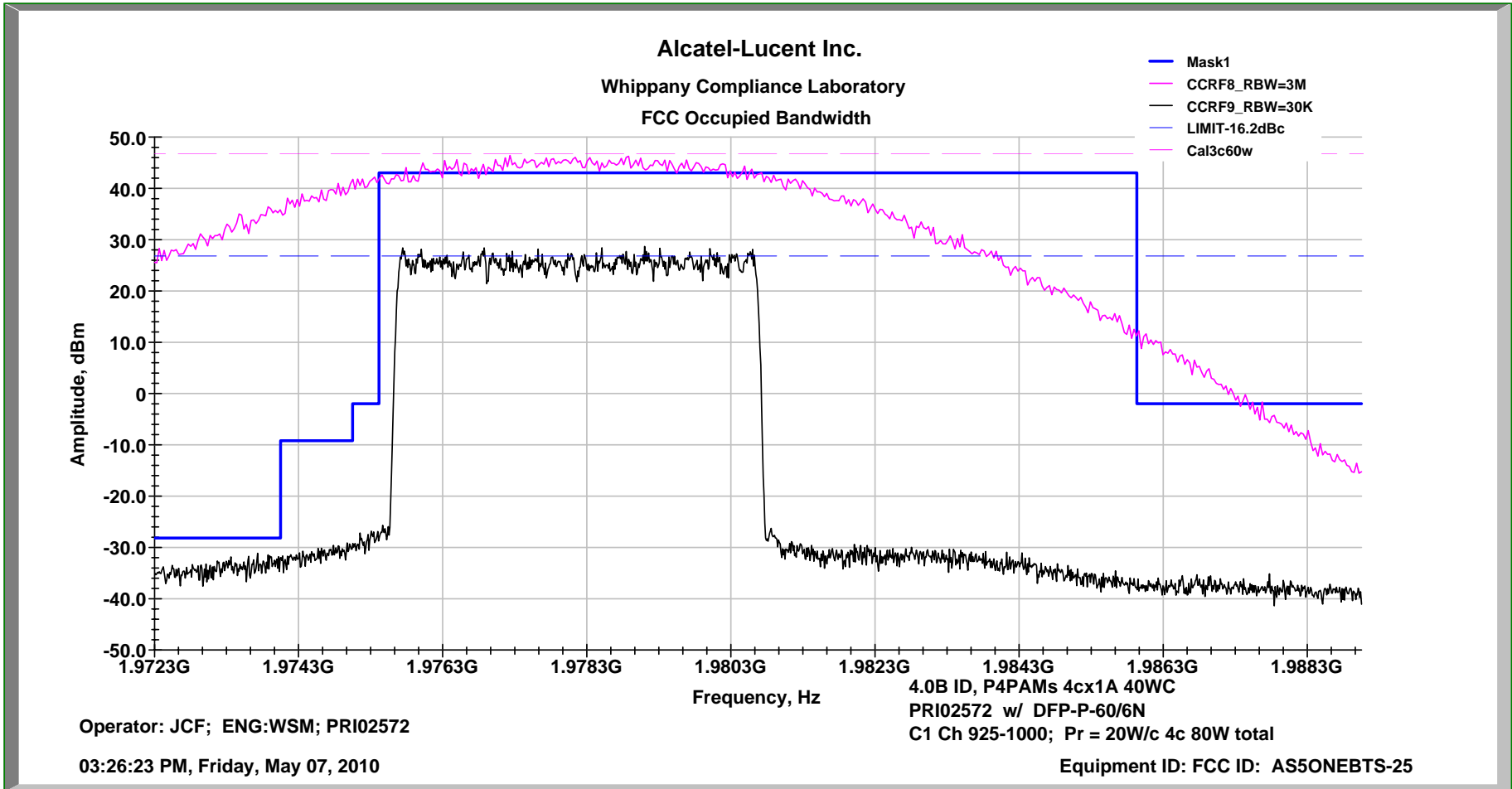


**In-band Inter-modulation    PCS Ch FC-825-900    Andrew P4PAM 4cx1A    80W Total**

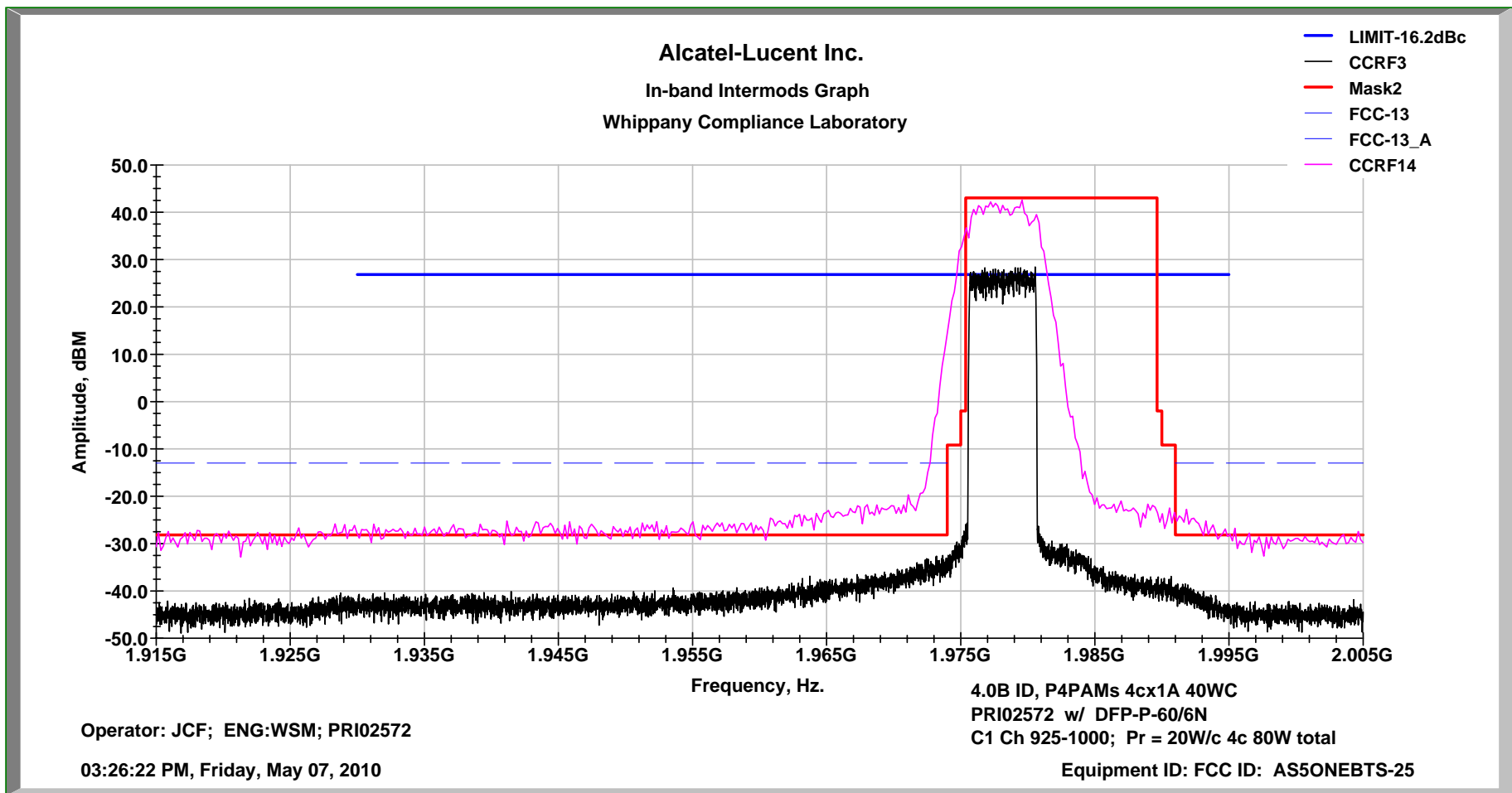




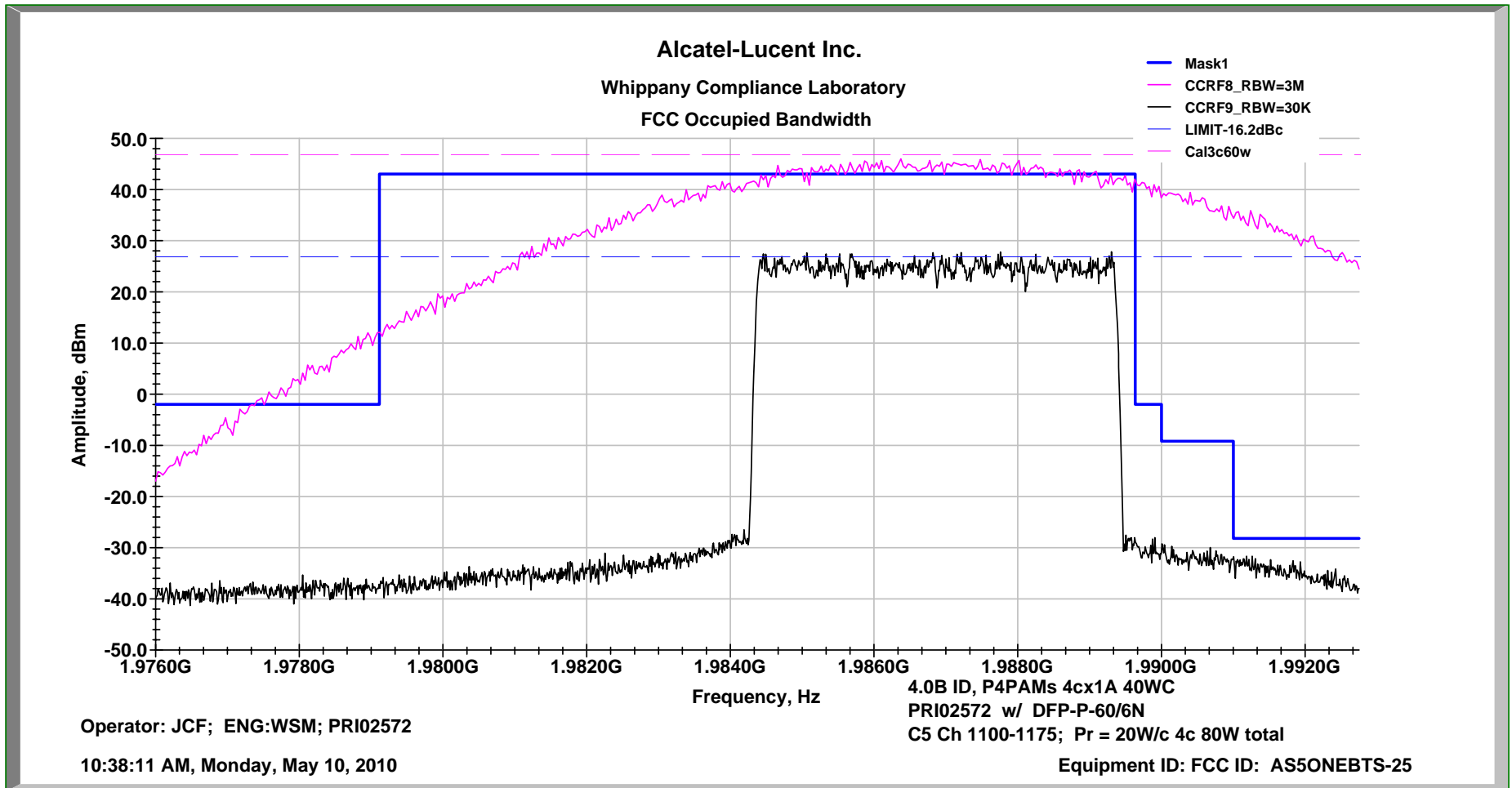
**Occupied Bandwidth PCS Ch C1-925- 1000 Andrew P4PAM 4cx1A 80W Total**



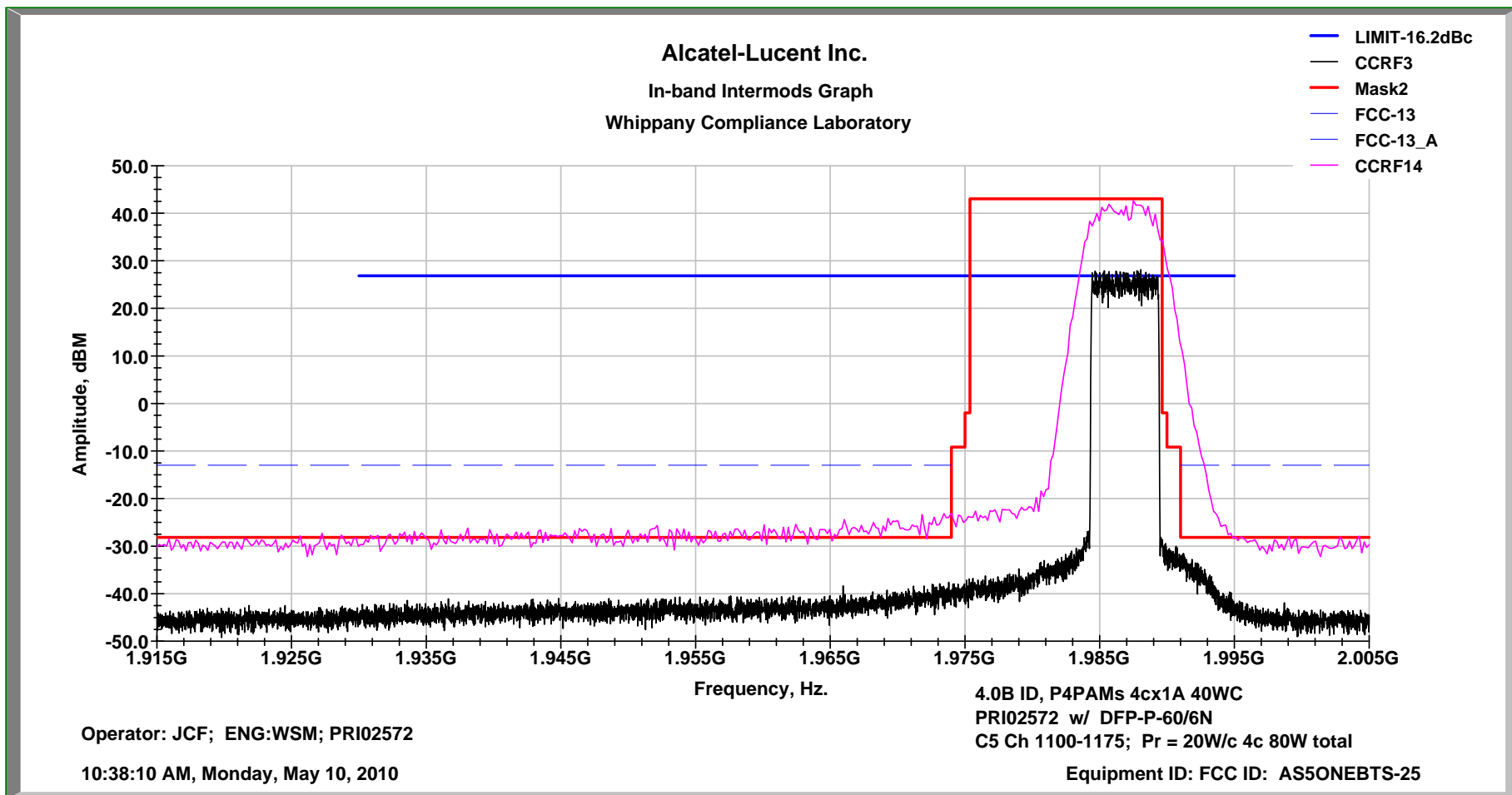
**In-band Inter-modulation    PCS Ch C1-925-1000    Andrew P4PAM 4cx1A    80W Total**



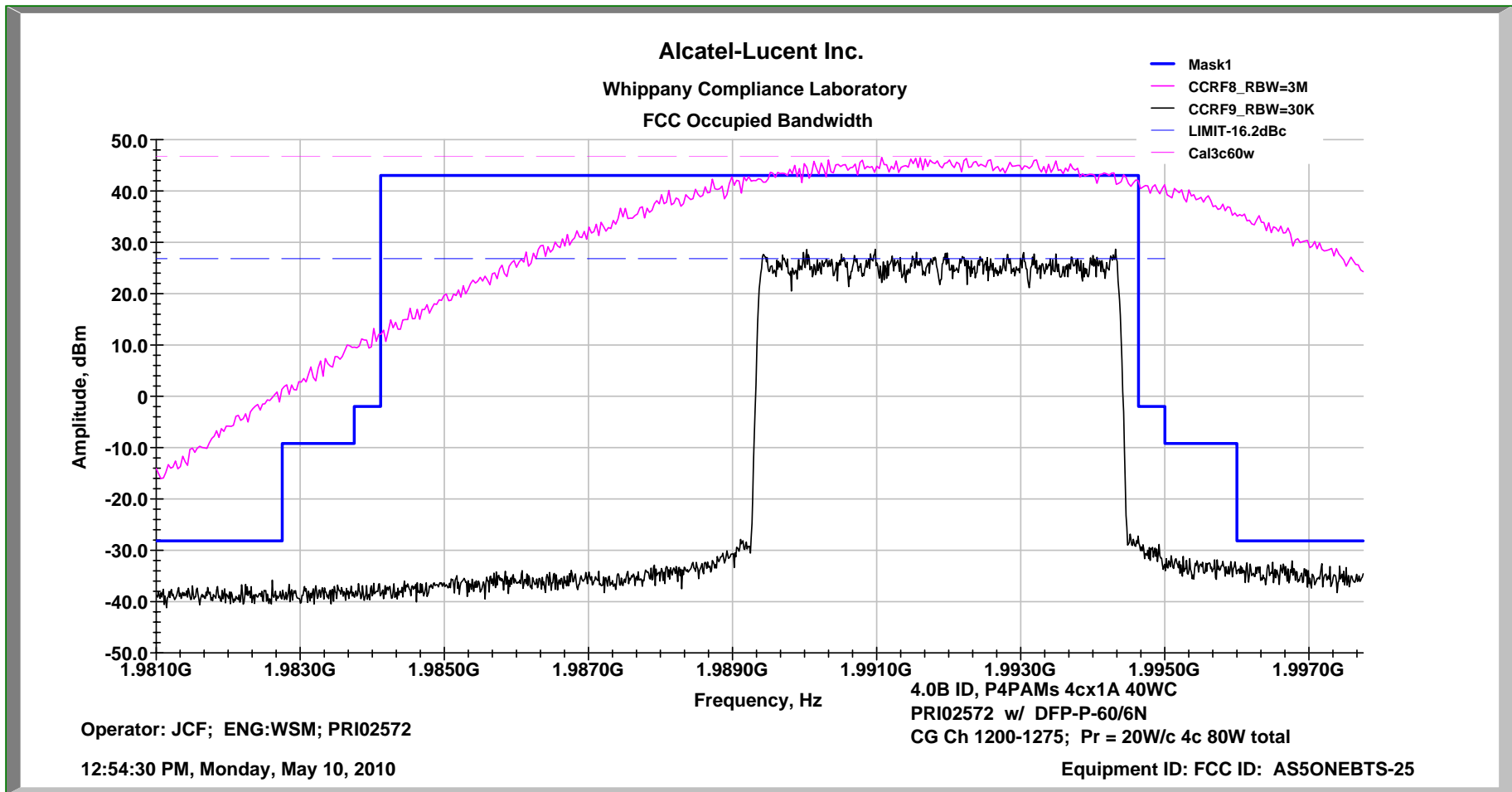
### Occupied Bandwidth PCS Ch C5-1100-1175 Andrew P4PAM 4cx1A 80W Total



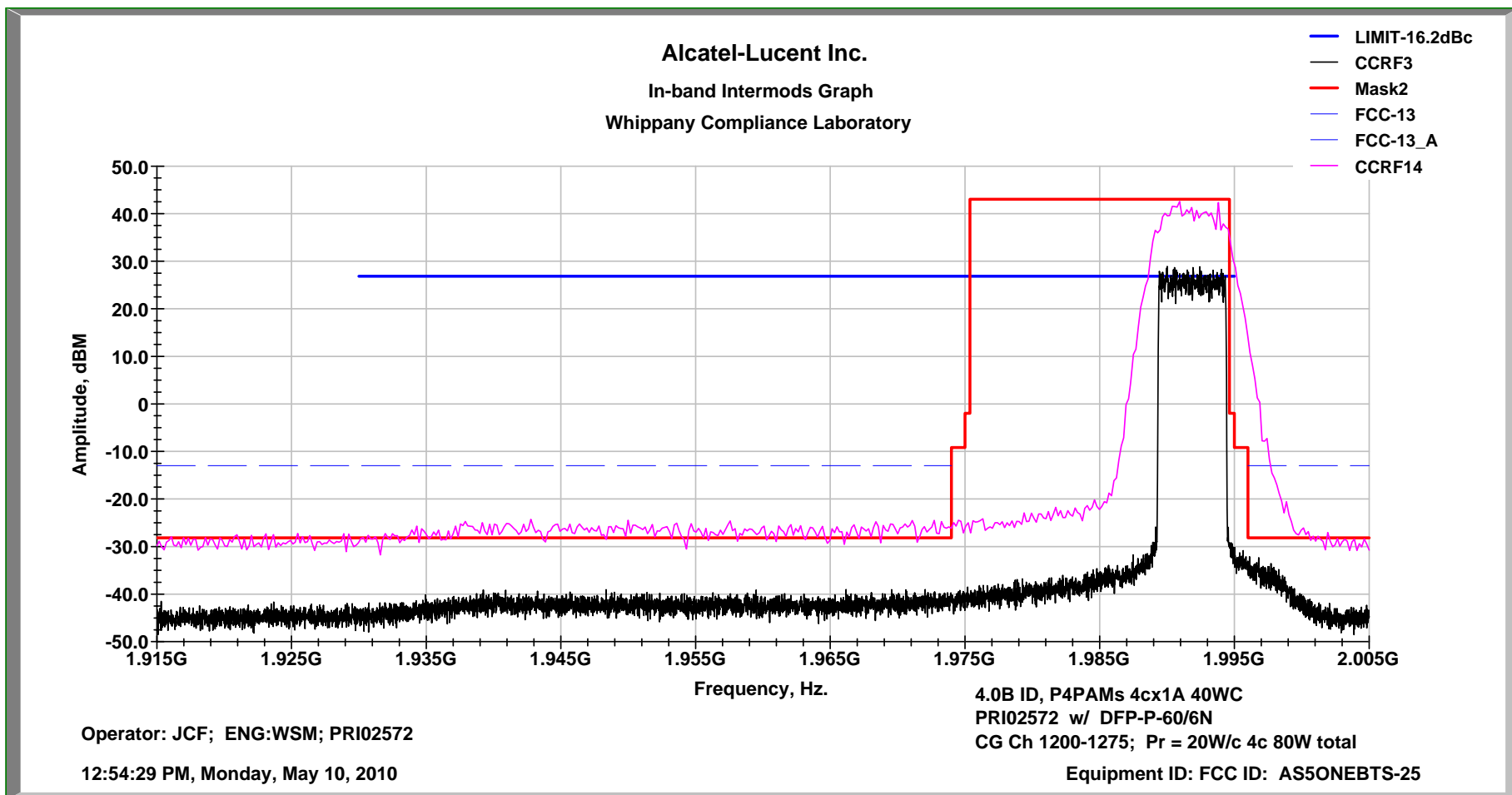
**In-band Inter-modulation    PCS Ch C5-1100-1175   Andrew P4PAM   4cx1A   80W Total**



### Occupied Bandwidth PCS Ch CG-1200-1275 Andrew P4PAM 4cx1A 80W Total



**In-band Inter-modulation      PCS Ch CG-1200-1275 Andrew P4PAM 4cx1A      80W Total**



**Two Amplifier Four Carrier  
80 W/Amp 160W Total  
Occupied Bandwidth Data  
PCS Blocks A through G  
Left side of Block, Right side of Block  
And  
PCS Band Intermodulation**

**4c x 2A 40W/c**

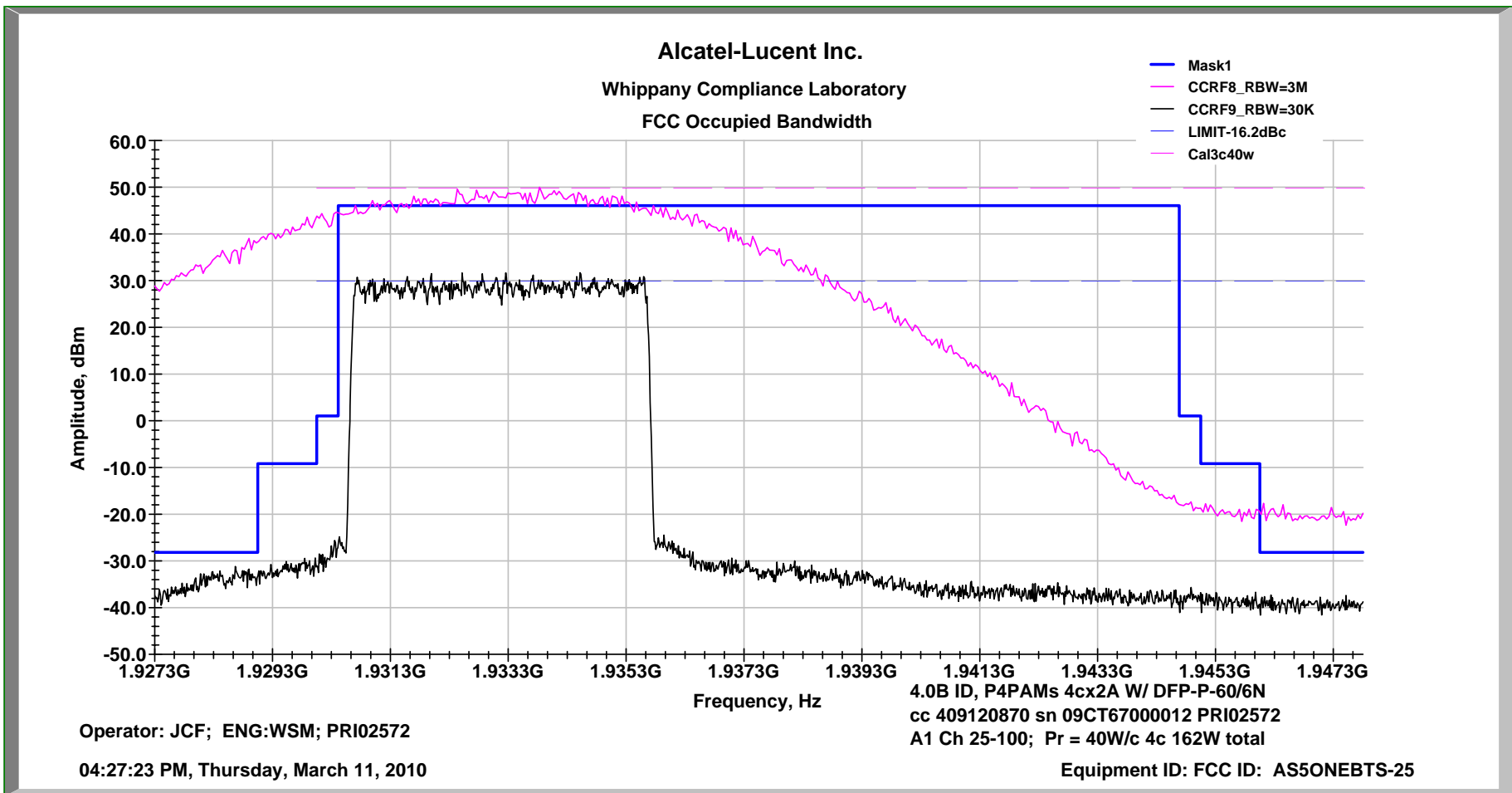
**Occupied Bandwidth**

**PCS Ch A1-25-100**

**P4PAM**

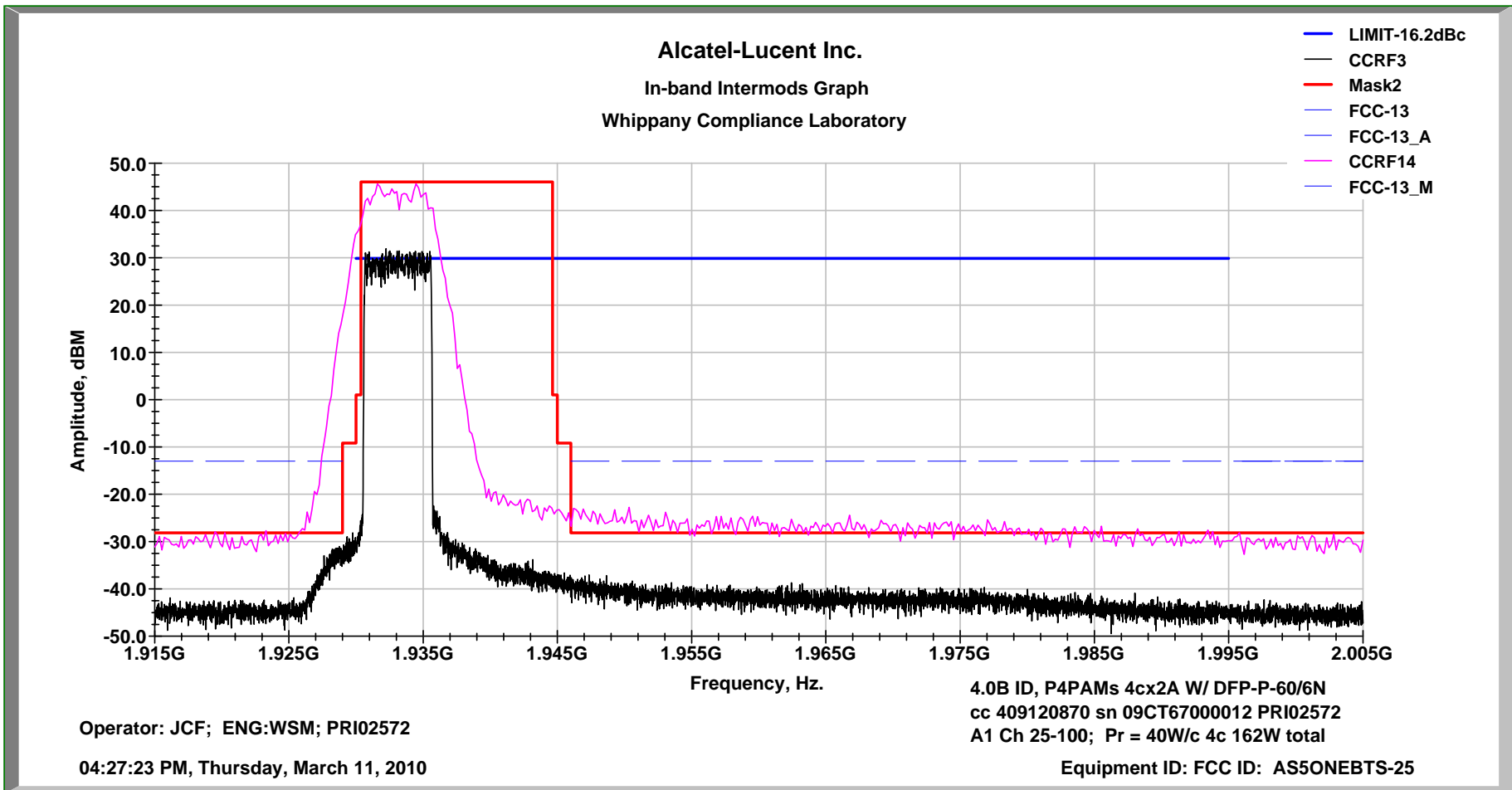
**4cx2A**

**2Gv 40W/c 160W Total**

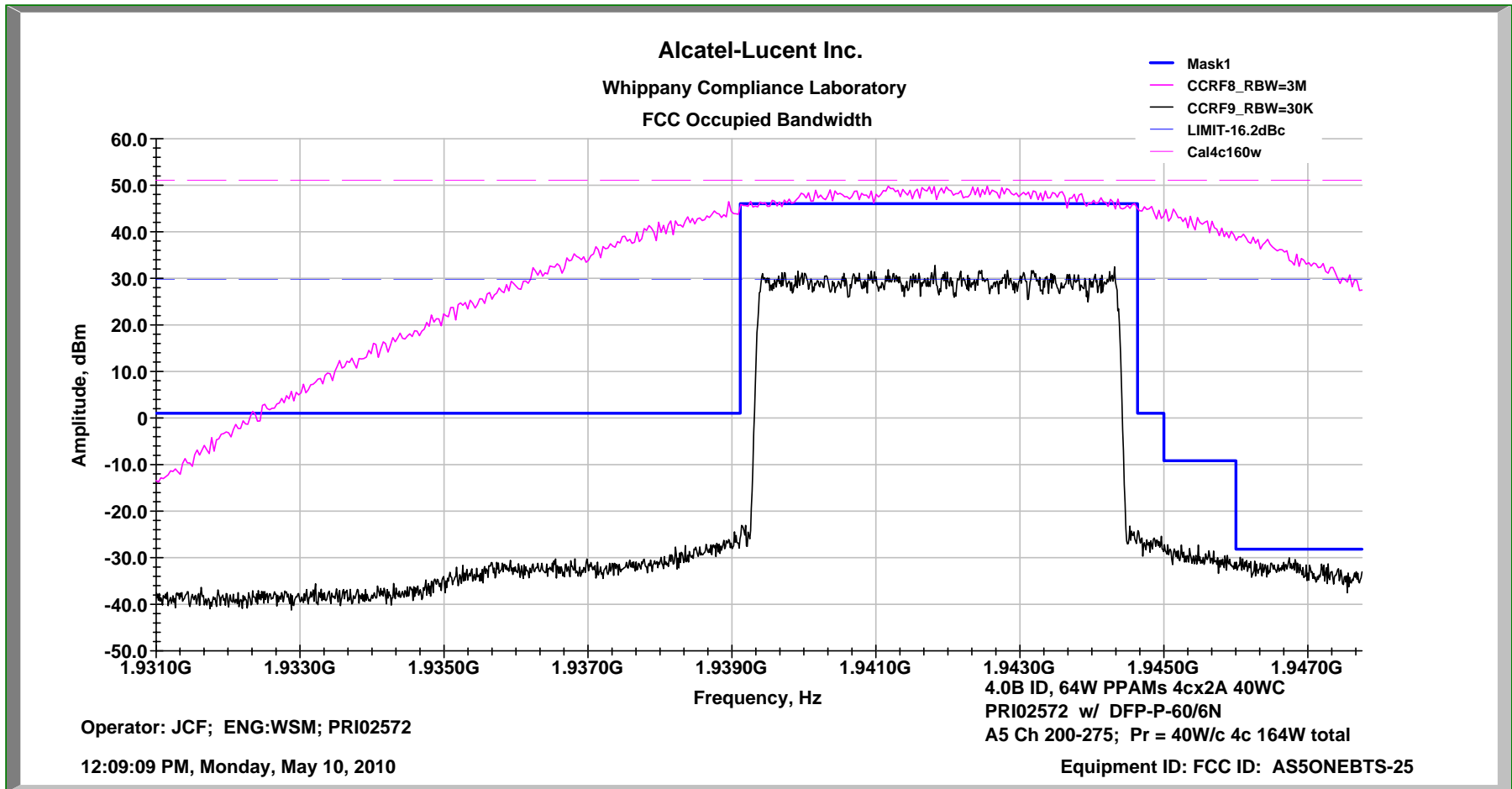




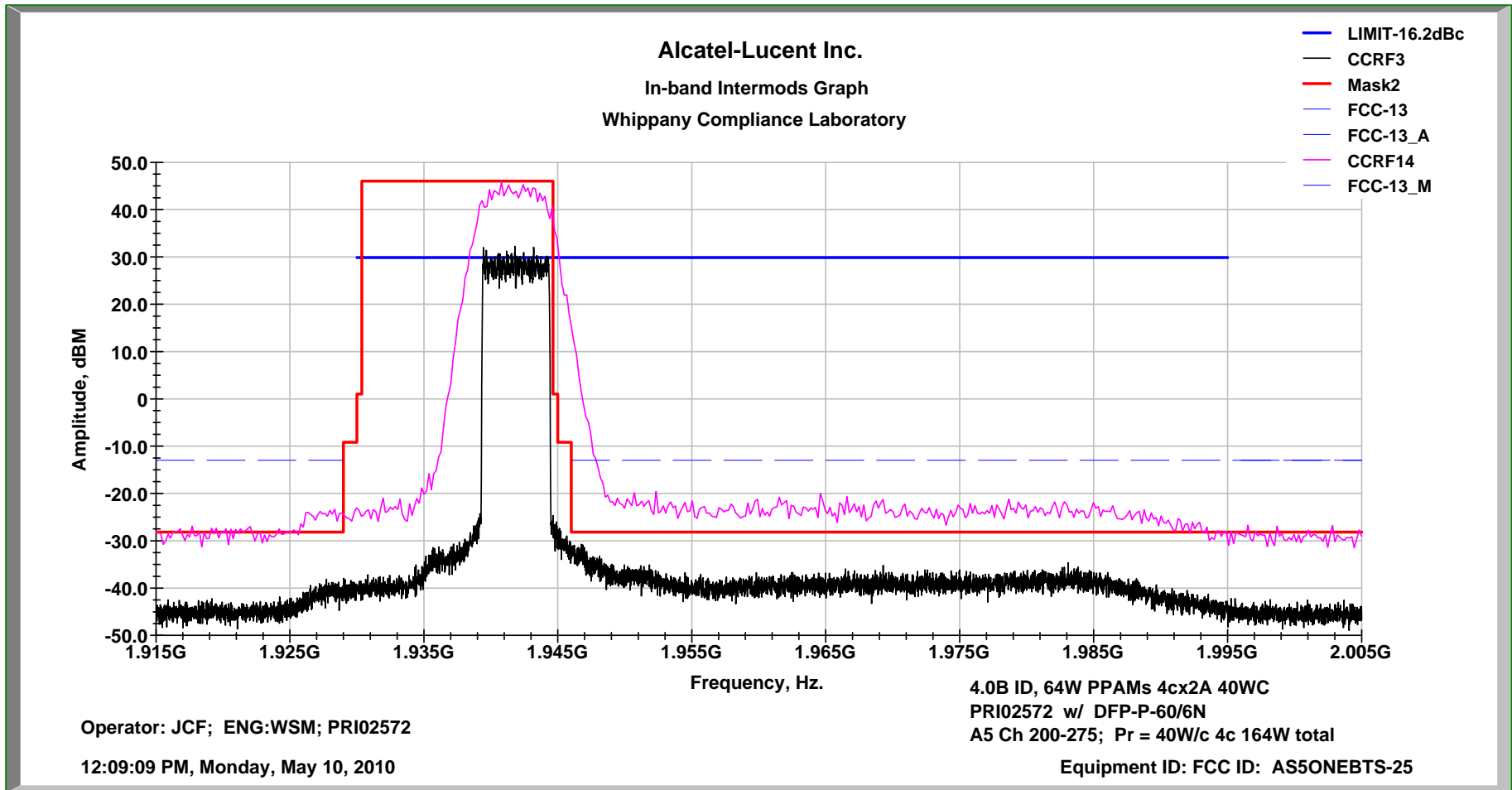
**In-band Inter-modulation    PCS Ch A1-25-100    P4PAM    4cx2A    2Gv    40W/c    160W Total**



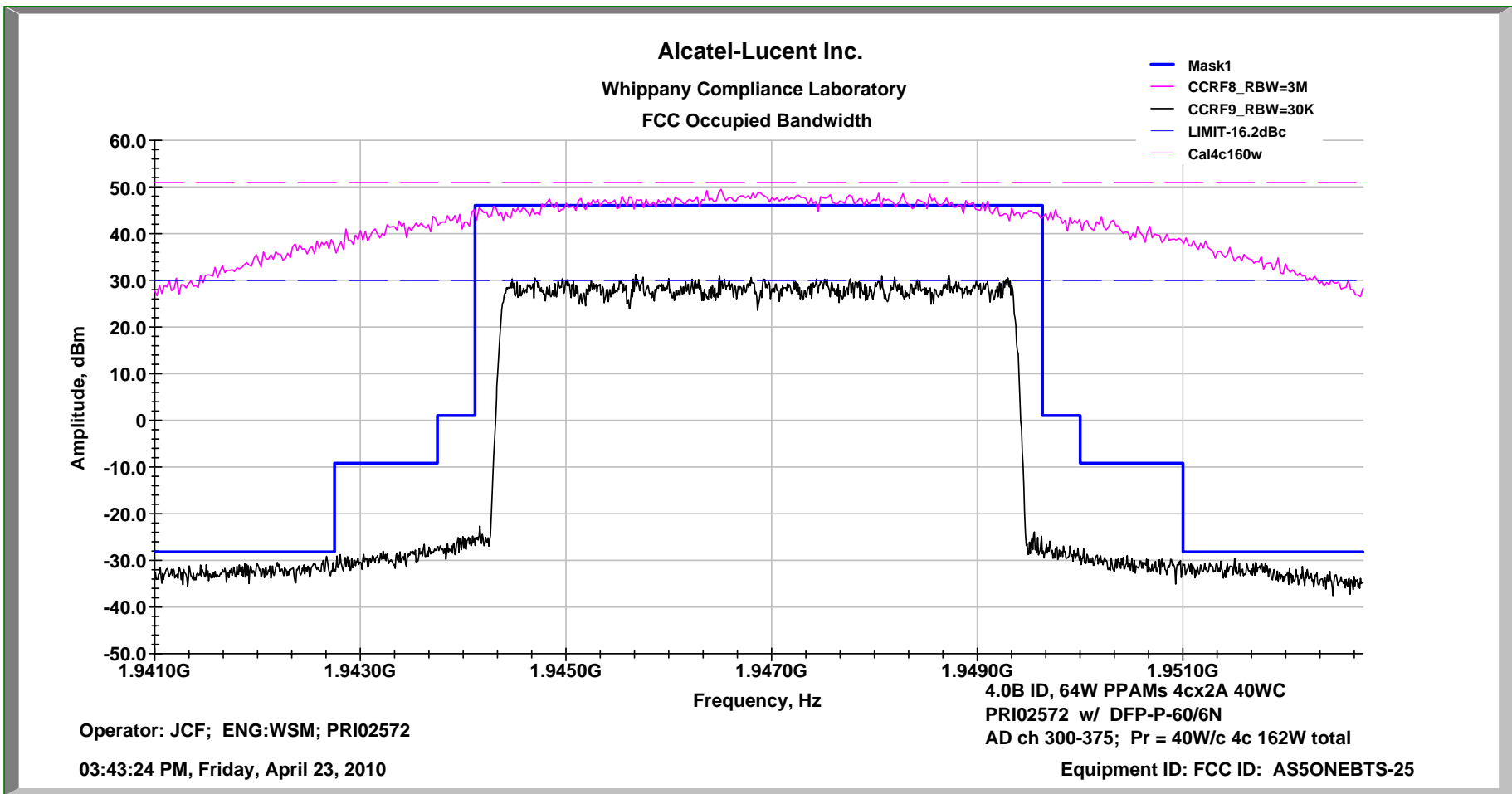
**Occupied Bandwidth      PCS Ch A5-200 – 275   P4PAM      4cx2A      2Gv   40W/c   160W Total**



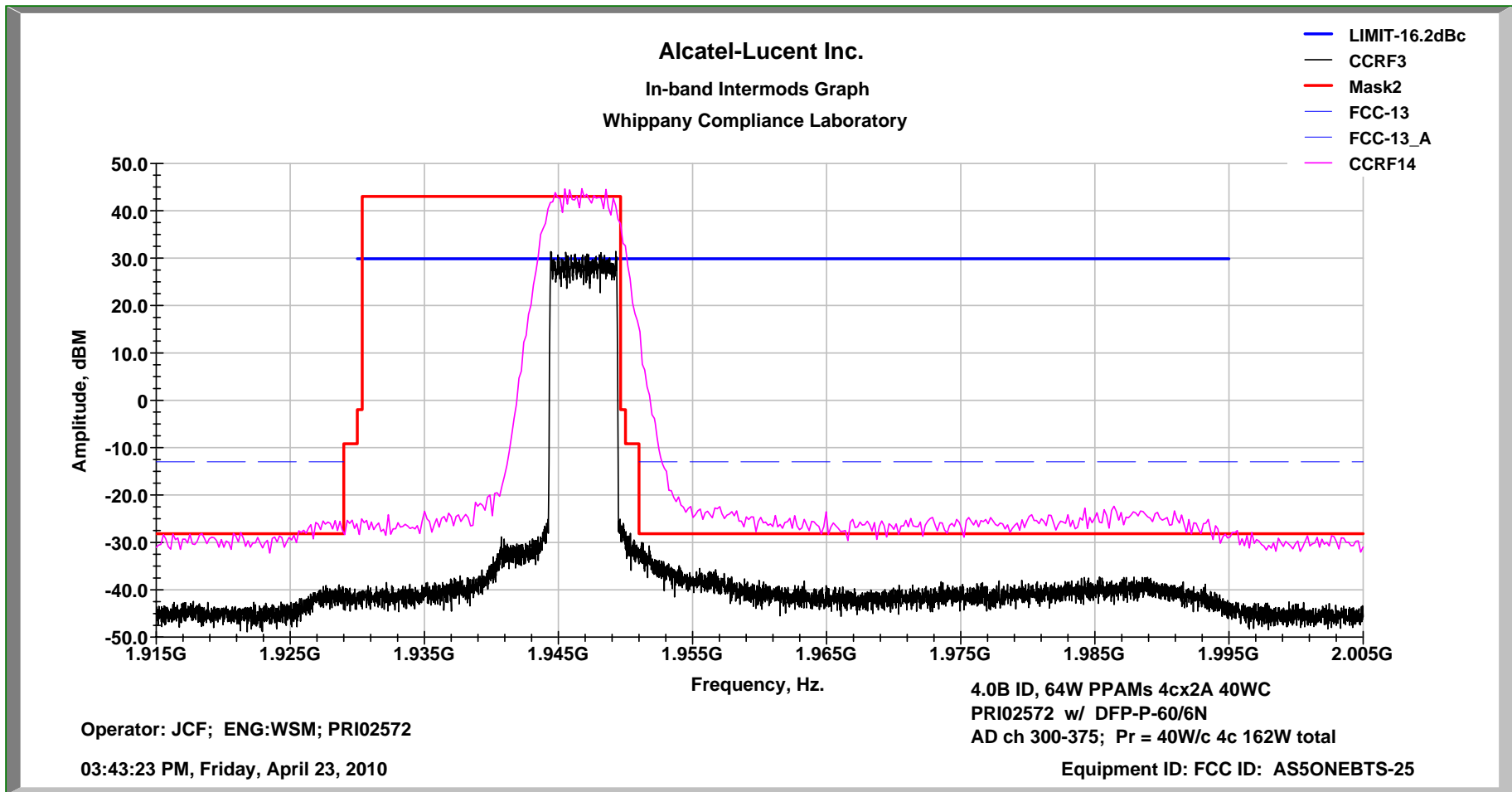
**In-band Inter-modulation    PCS Ch A5-200 – 275   P4PAM    4cx2A    2Gv   40W/c   160W Total**



**Occupied Bandwidth      PCS Ch AD-300 – 375   P4PAM      4cx2A      2Gv   40W/c   160W Total**

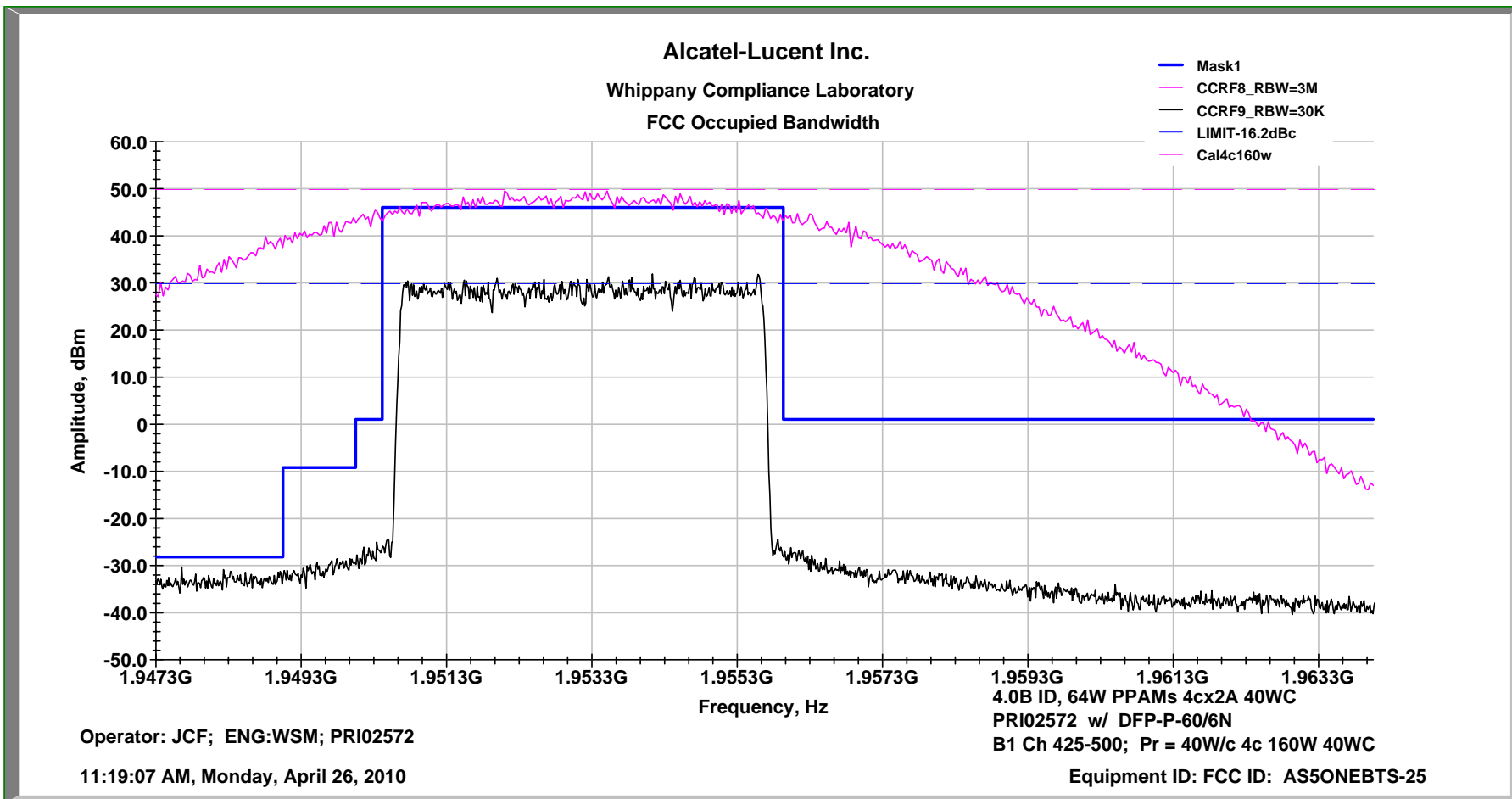


**In-band Inter-modulation    PCS Ch AD-300 – 375   P4PAM    4cx2A    2Gv   40W/c   160W Total**

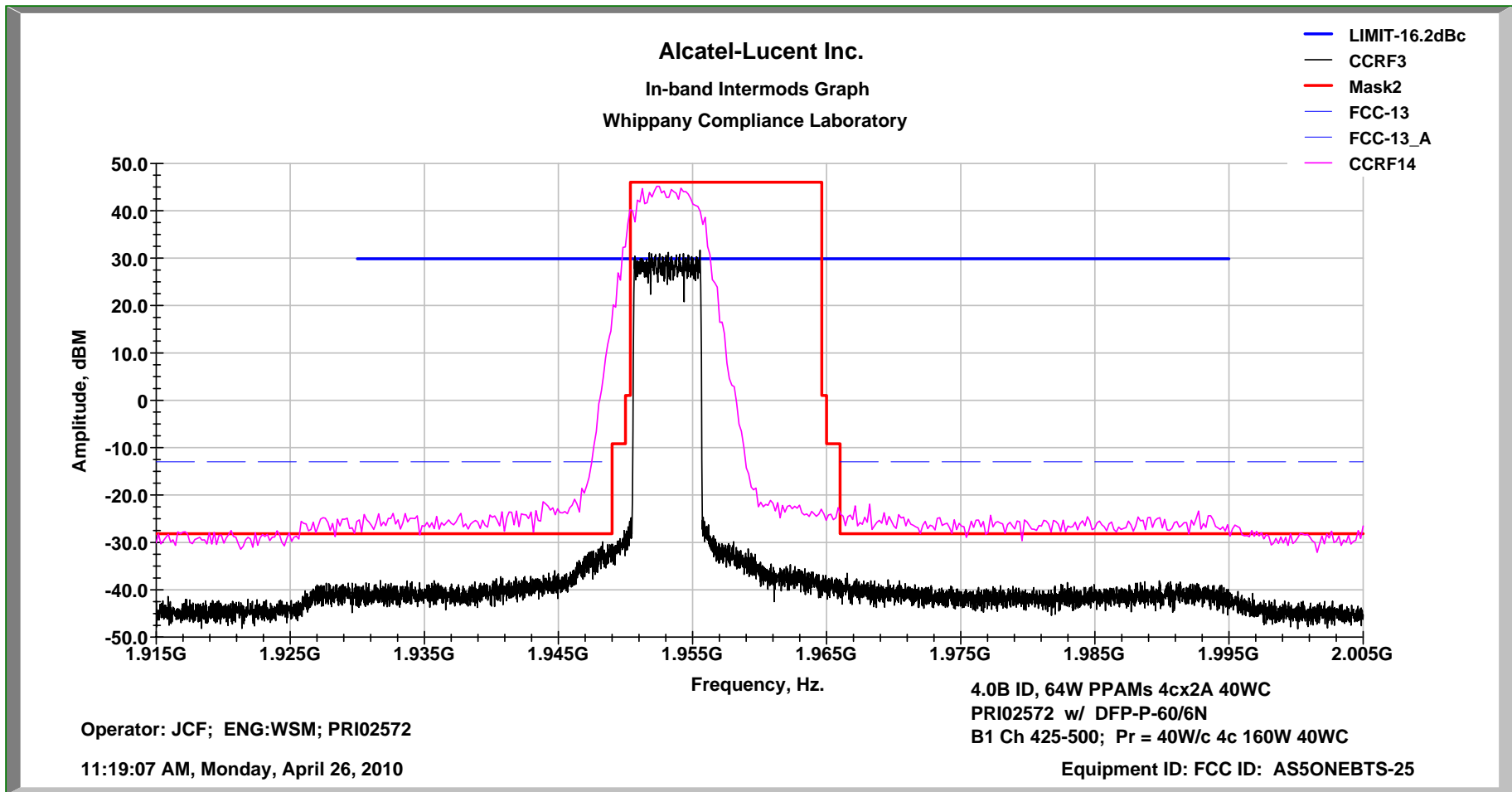


**Occupied Bandwidth**

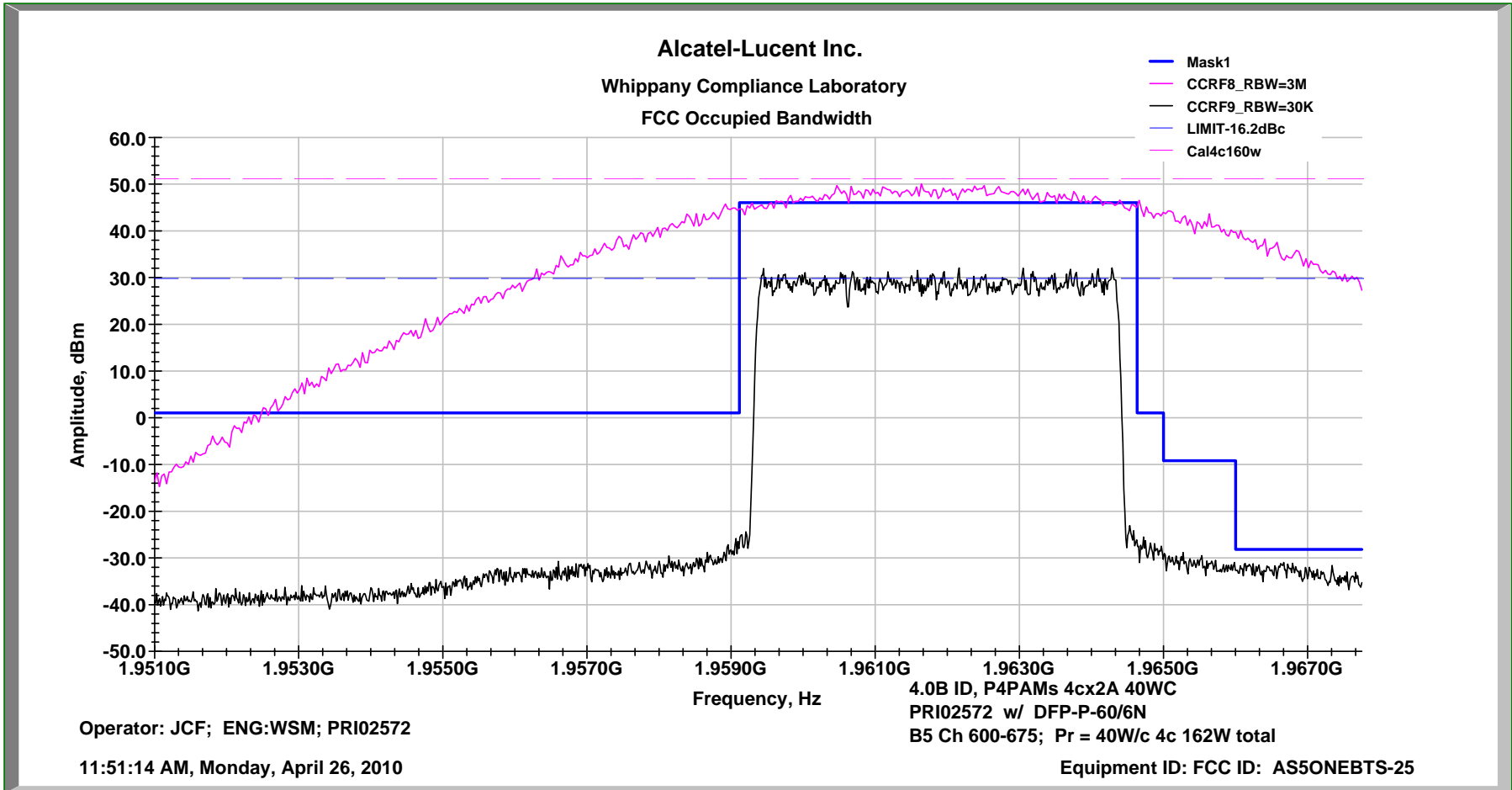
**PCS Ch B1 425 – 500 P4PAM 4cx2A 2Gv 40W/c 160W Total**



**In-band Inter-modulation    PCS Ch B1 425 – 500   P4PAM    4cx2A    2Gv   40W/c   160W Total**

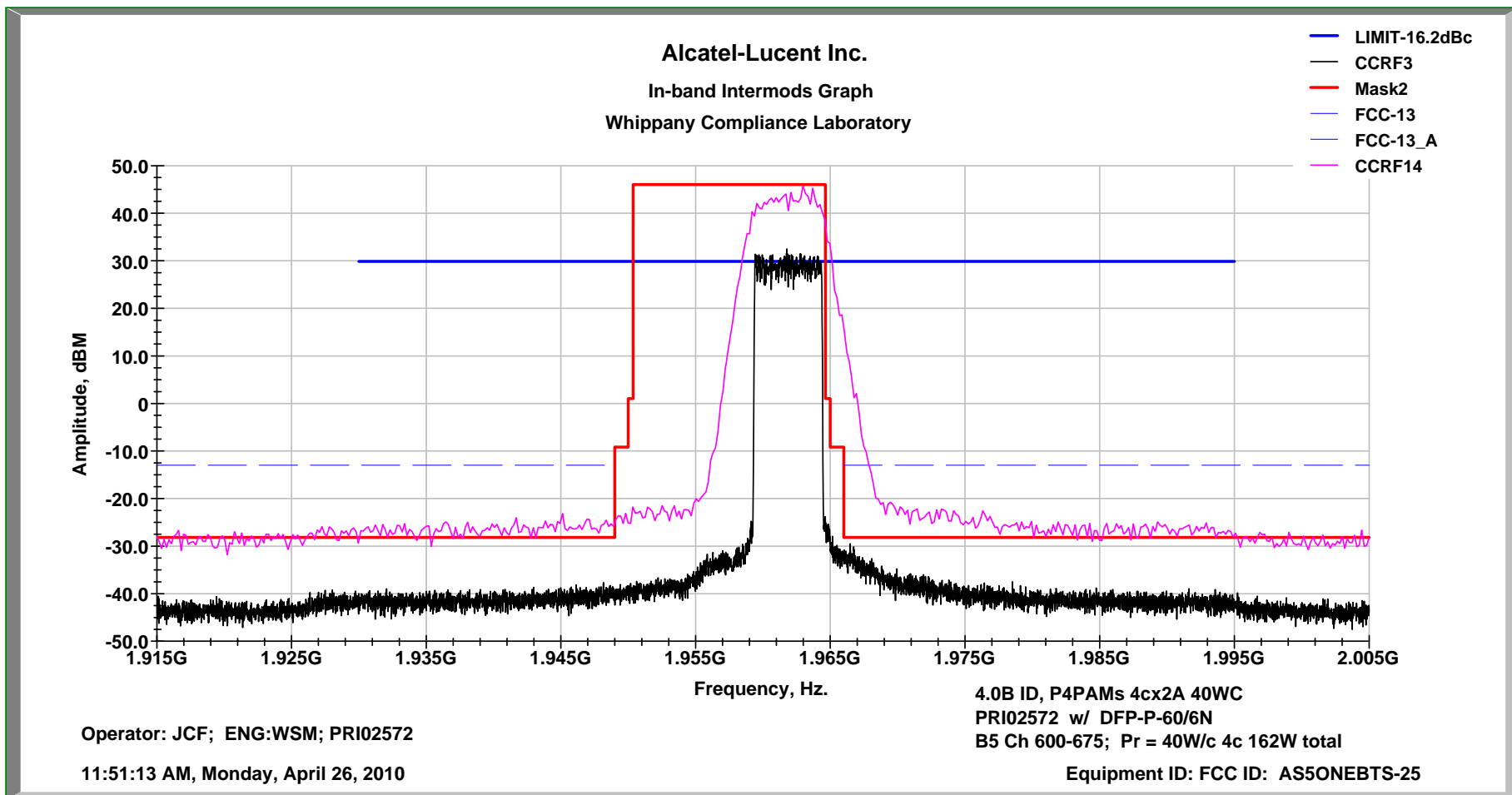


**Occupied Bandwidth      PCS Ch B5-600 – 675 P4PAM      4cx2A      2Gv      40W/c      160W Total**



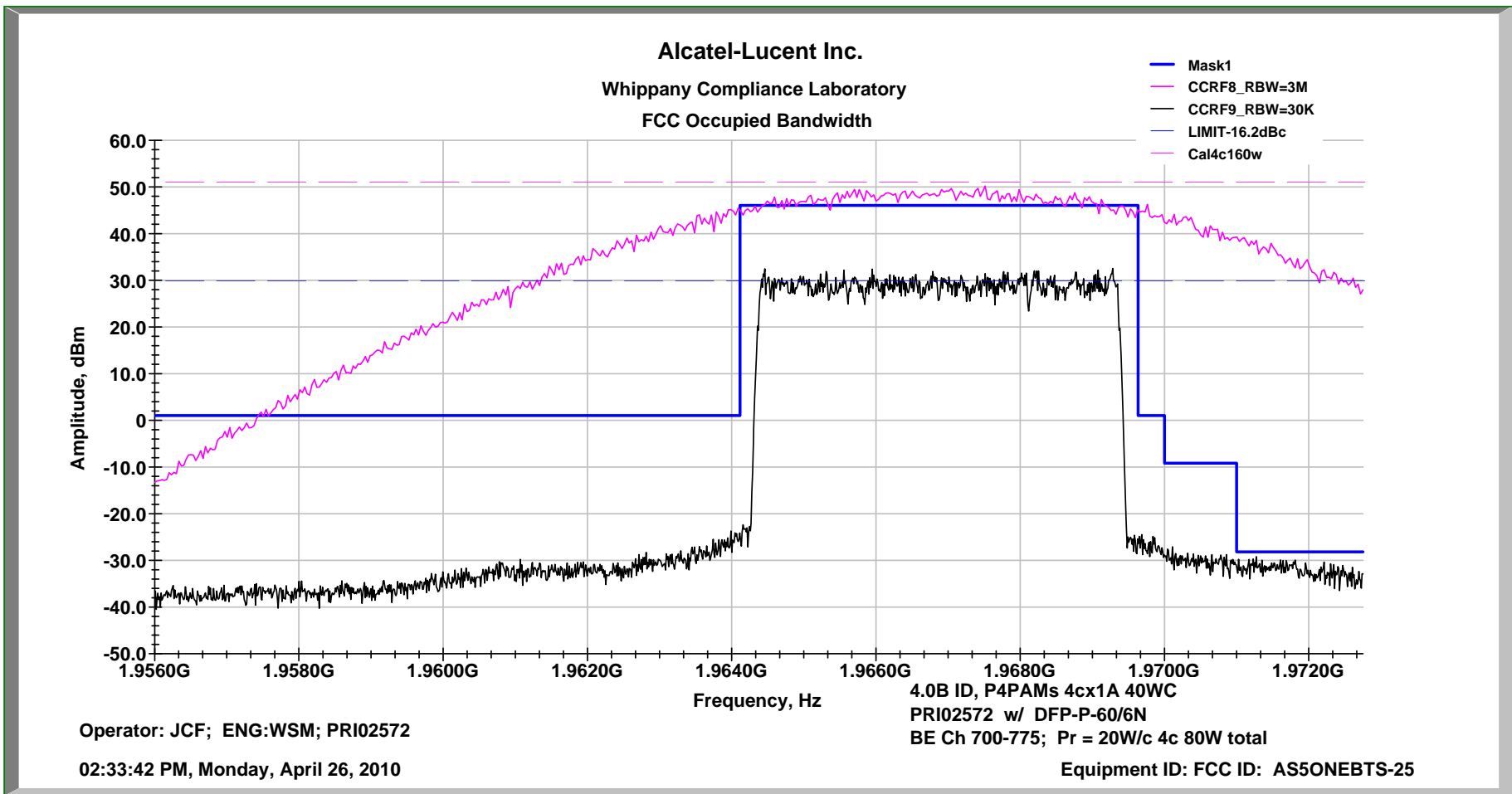


**In-band Inter-modulation    PCS Ch B5-600 – 675   P4PAM    4cx2A    2Gv   40W/c   160W Total**

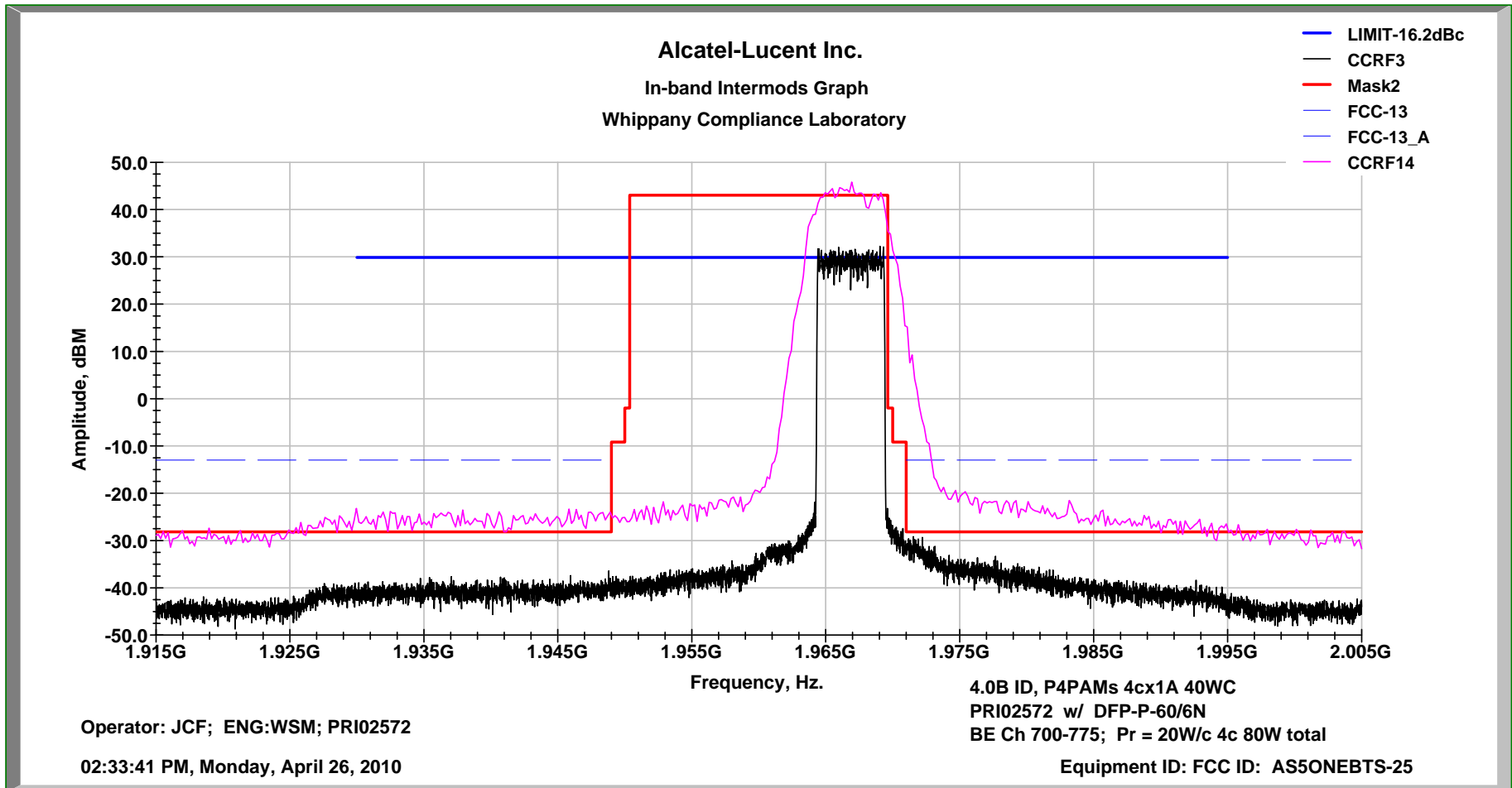


**Occupied Bandwidth**

**PCS Ch BE-700 – 775 P4PAM 4cx2A 2Gv 40W/c 160W Total**

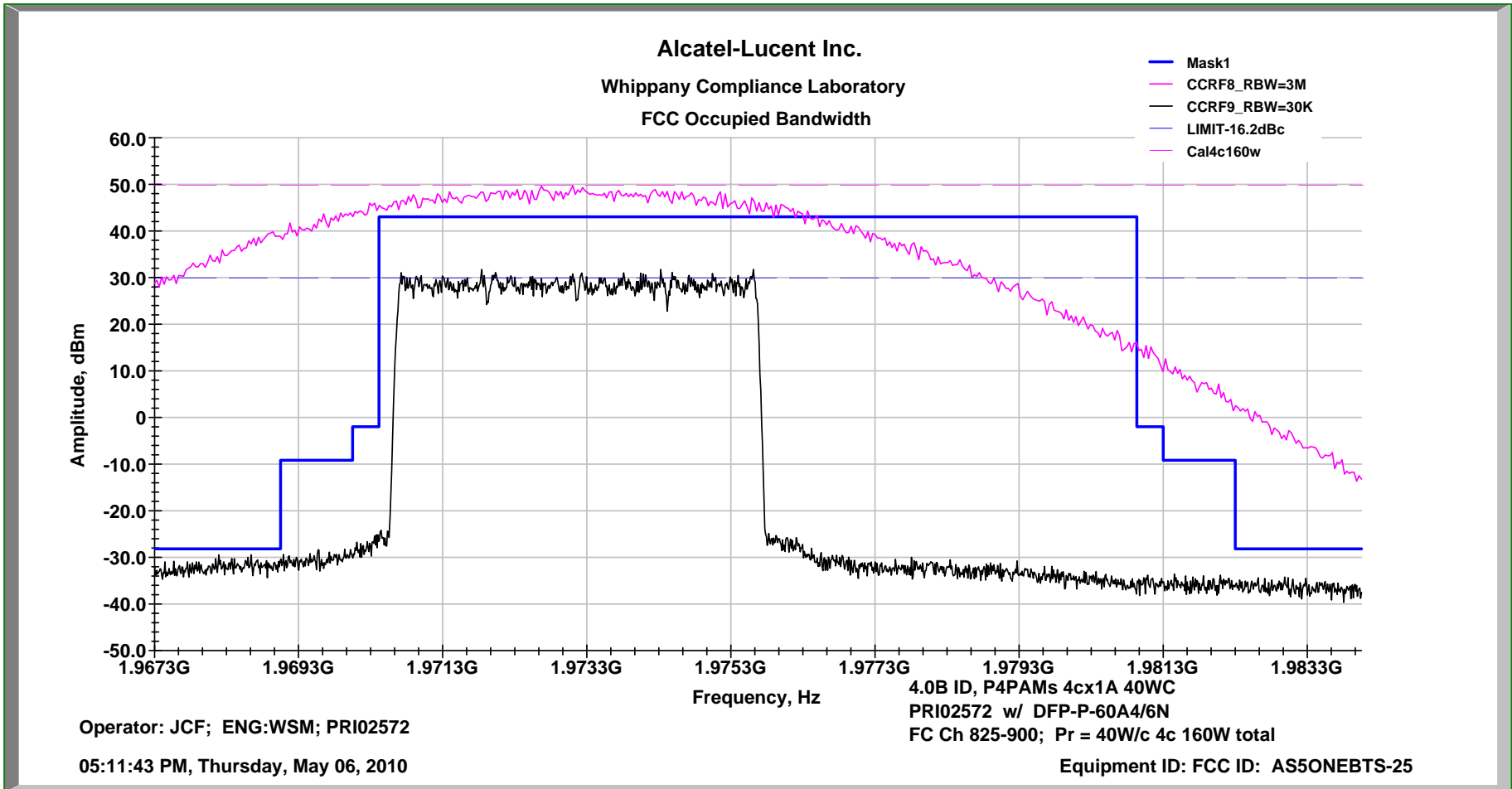


**In-band Inter-modulation    PCS Ch BE-700 – 775   P4PAM    4cx2A    2Gv   40W/c   160W Total**

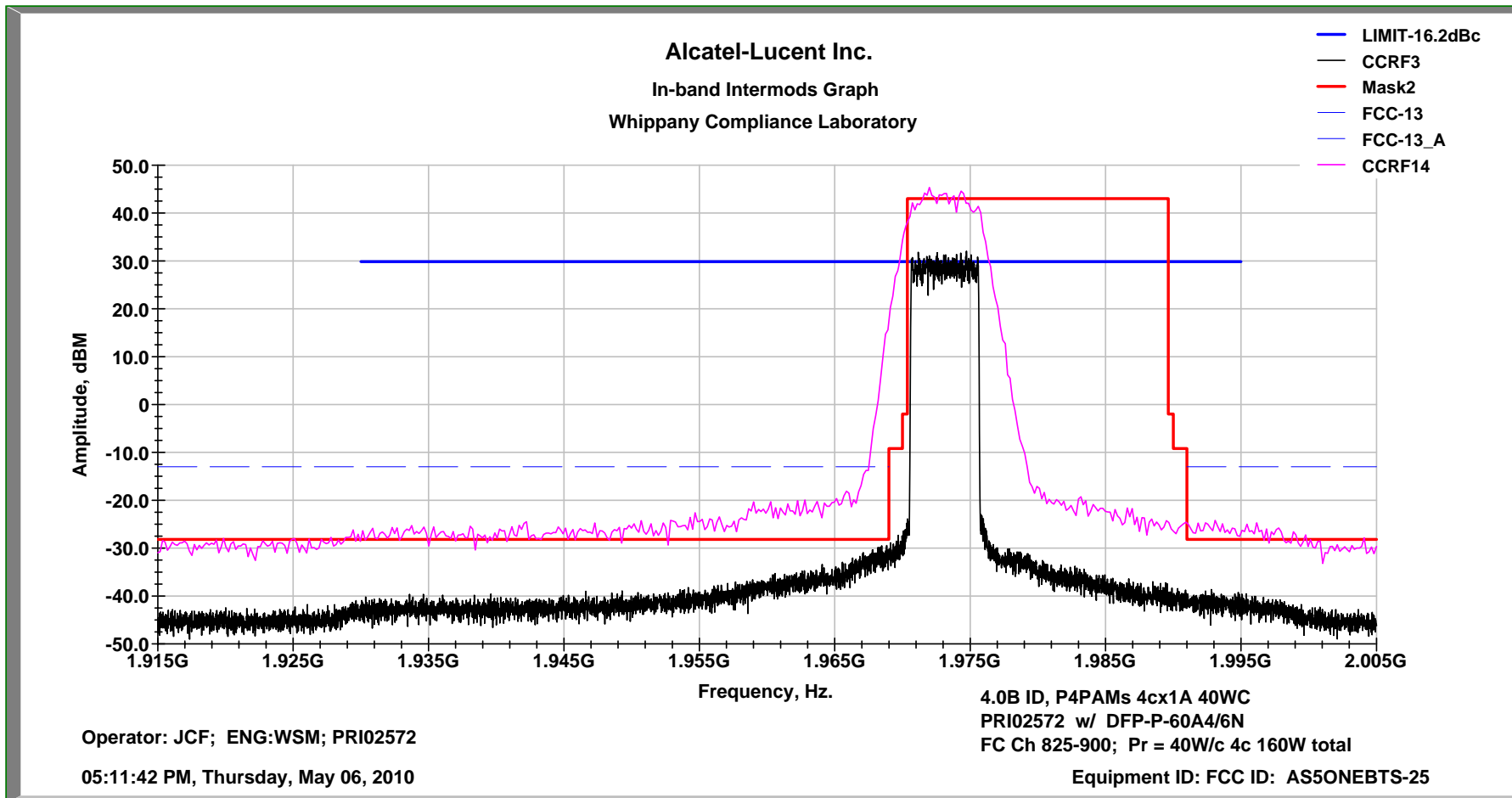


**Occupied Bandwidth**

**PCS Ch FC-825 – 900 P4PAM 4cx2A 2Gv 40W/c 160W Total**

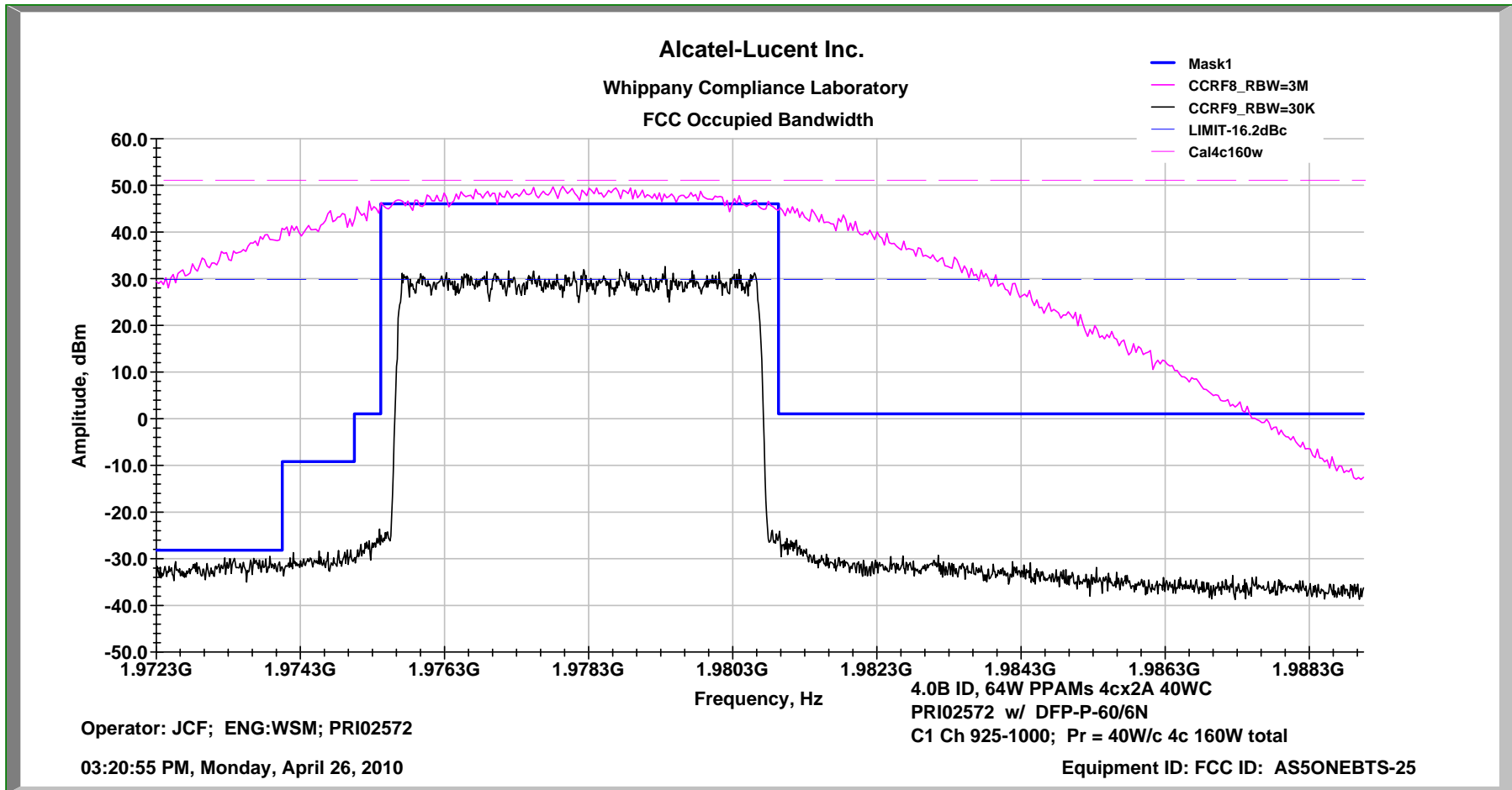


**In-band Inter-modulation    PCS Ch FC-825 – 900   P4PAM    4cx2A    2Gv   40W/c   160W Total**

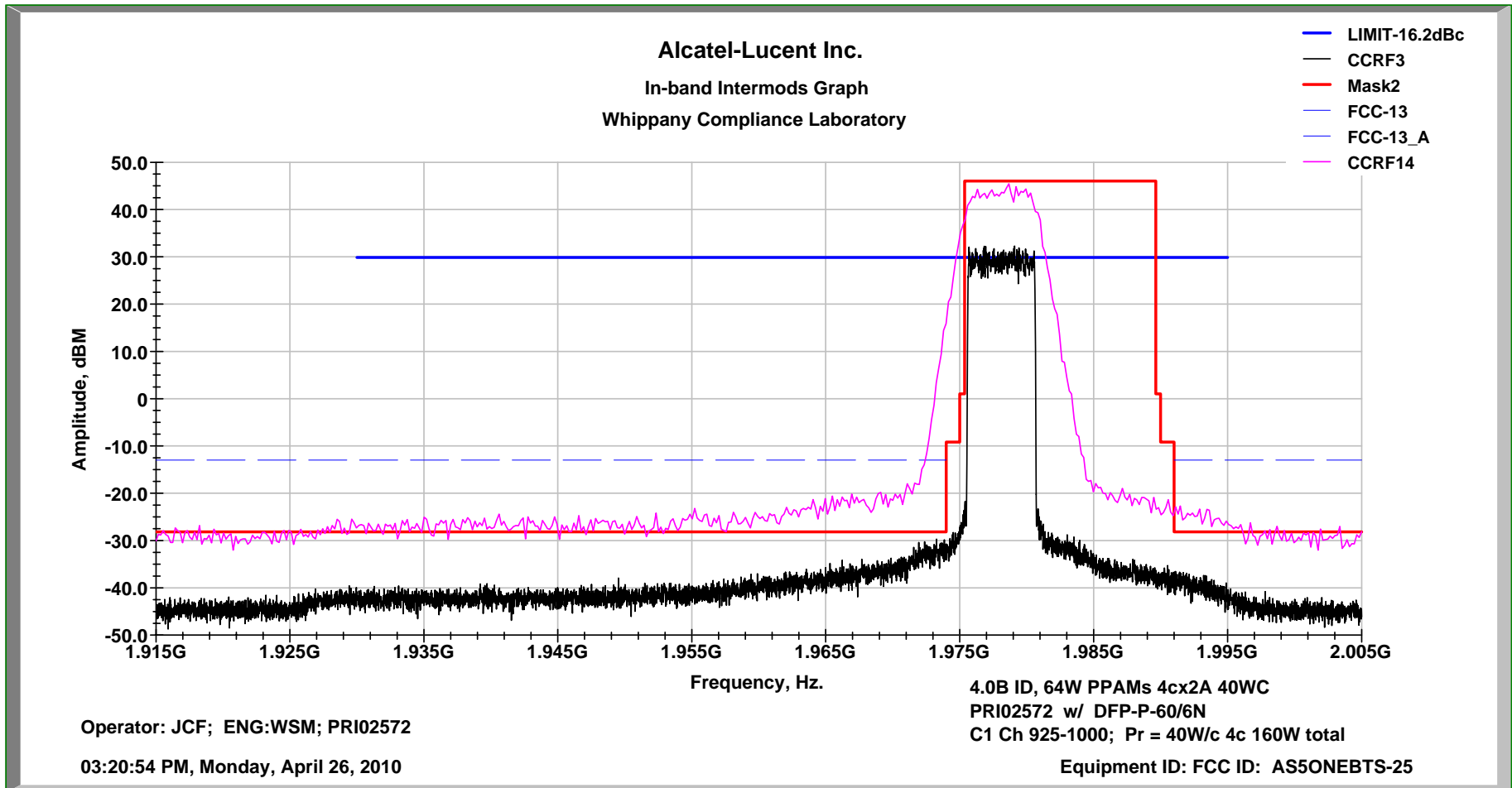


**Occupied Bandwidth**

**PCS Ch C1-925 – 1000 P4PAM 4cx2A 2Gv 40W/c 160W Total**

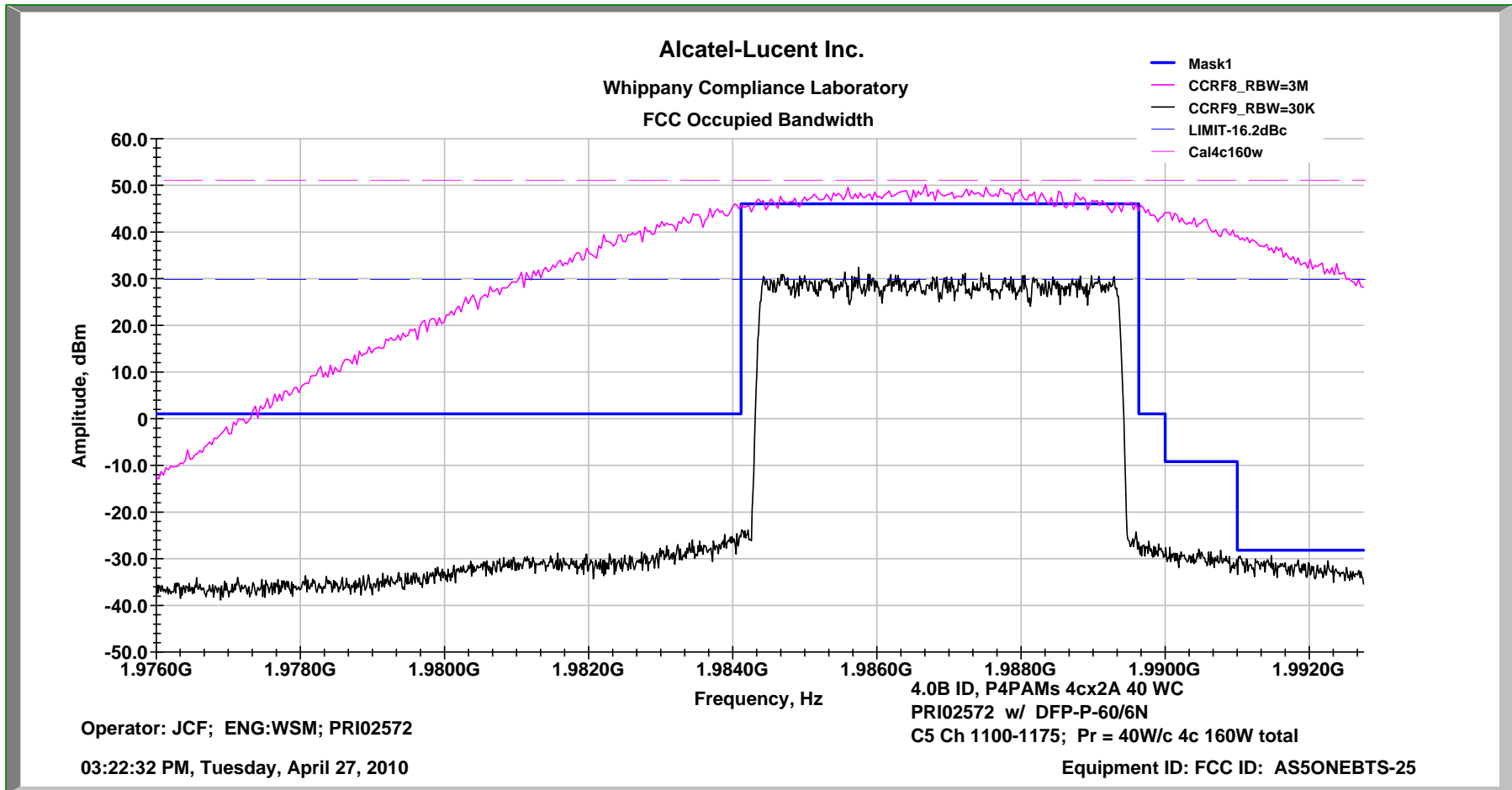


**In-band Inter-modulation    PCS Ch C1-925 – 1000   P4PAM   4cx2A   2Gv   40W/c   160W Total**



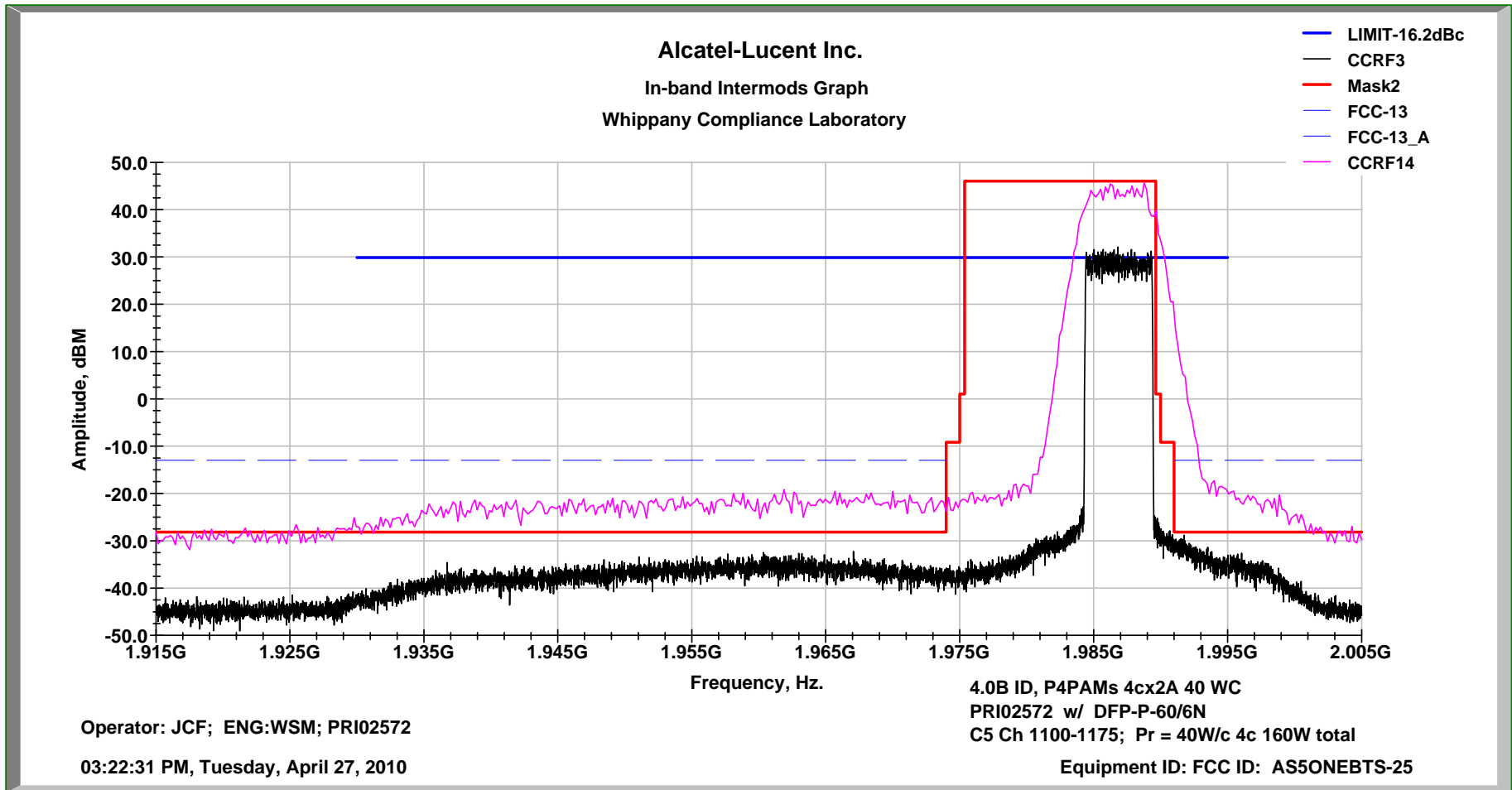
**Occupied Bandwidth**

**PCS Ch C5-1100 – 1175 P4PAM 4cx2A 2Gv 40W/c 160W Total**



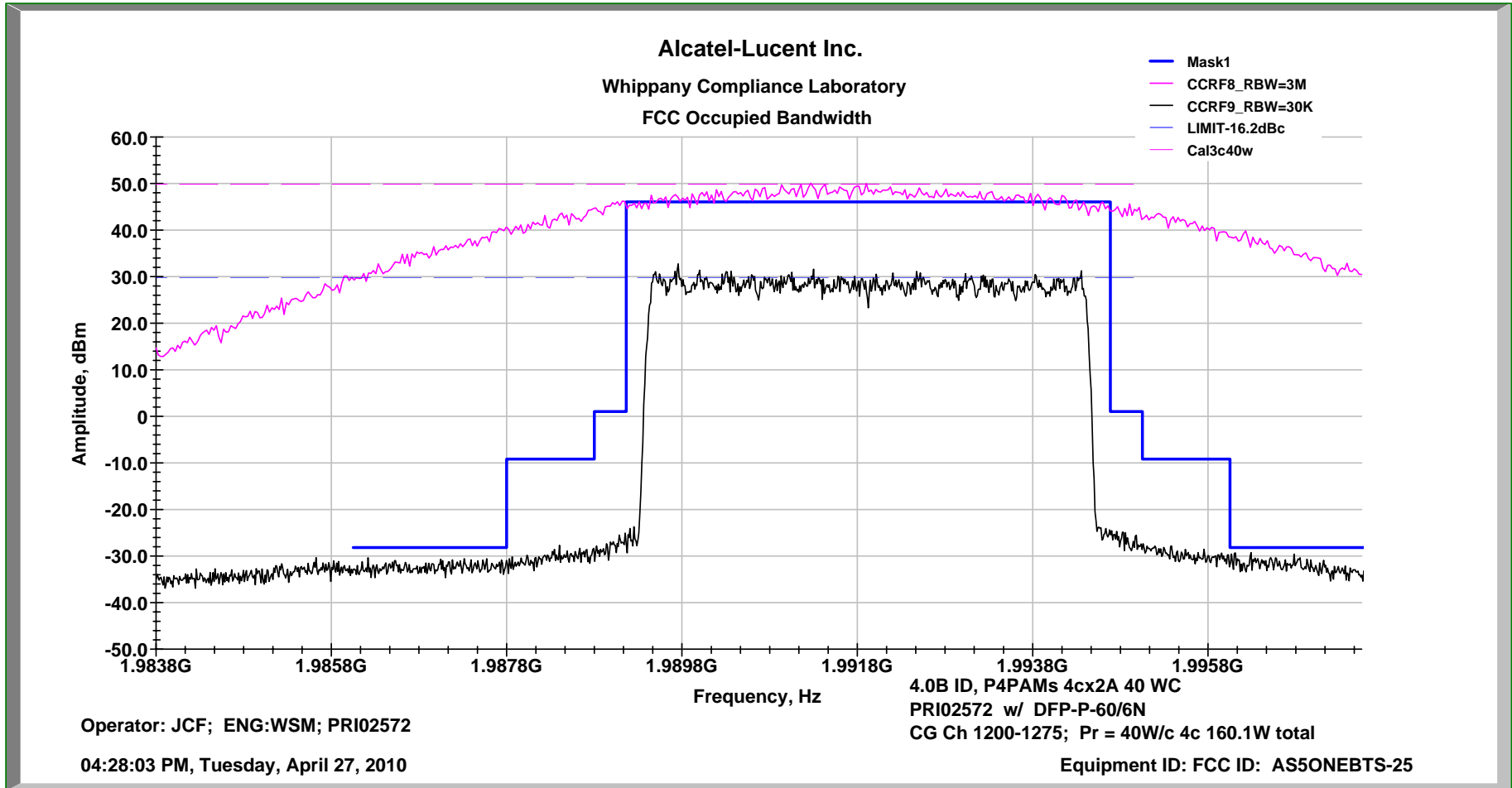


**In-band Inter-modulation    PCS Ch C5-1100 – 1175 P4PAM    4cx2A    2Gv    40W/c    160W Total**

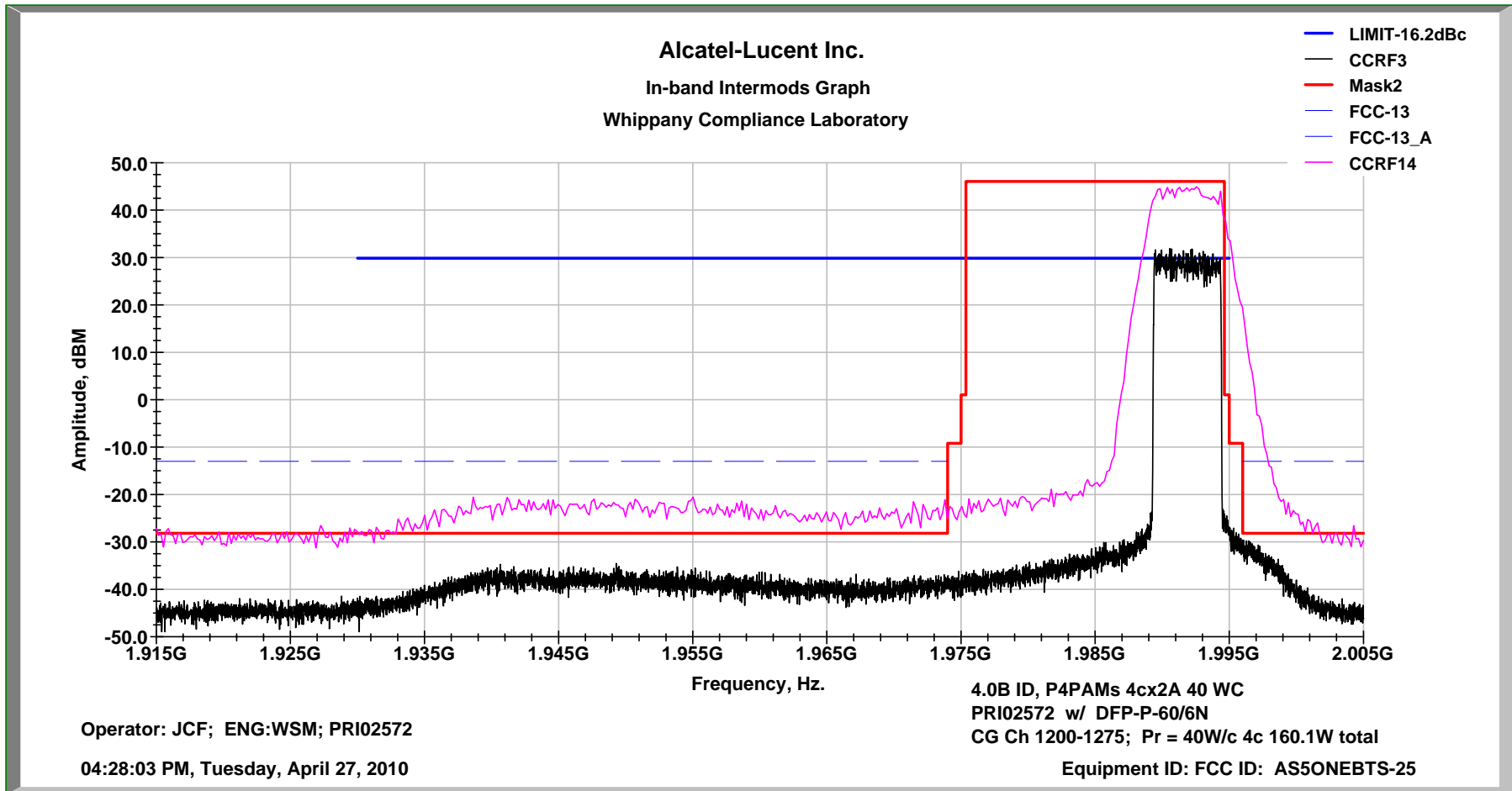


**Occupied Bandwidth**

**PCS Ch CG-1200 – 1275 P4PAM 4cx2A 2Gv 40W/c 160W Total**



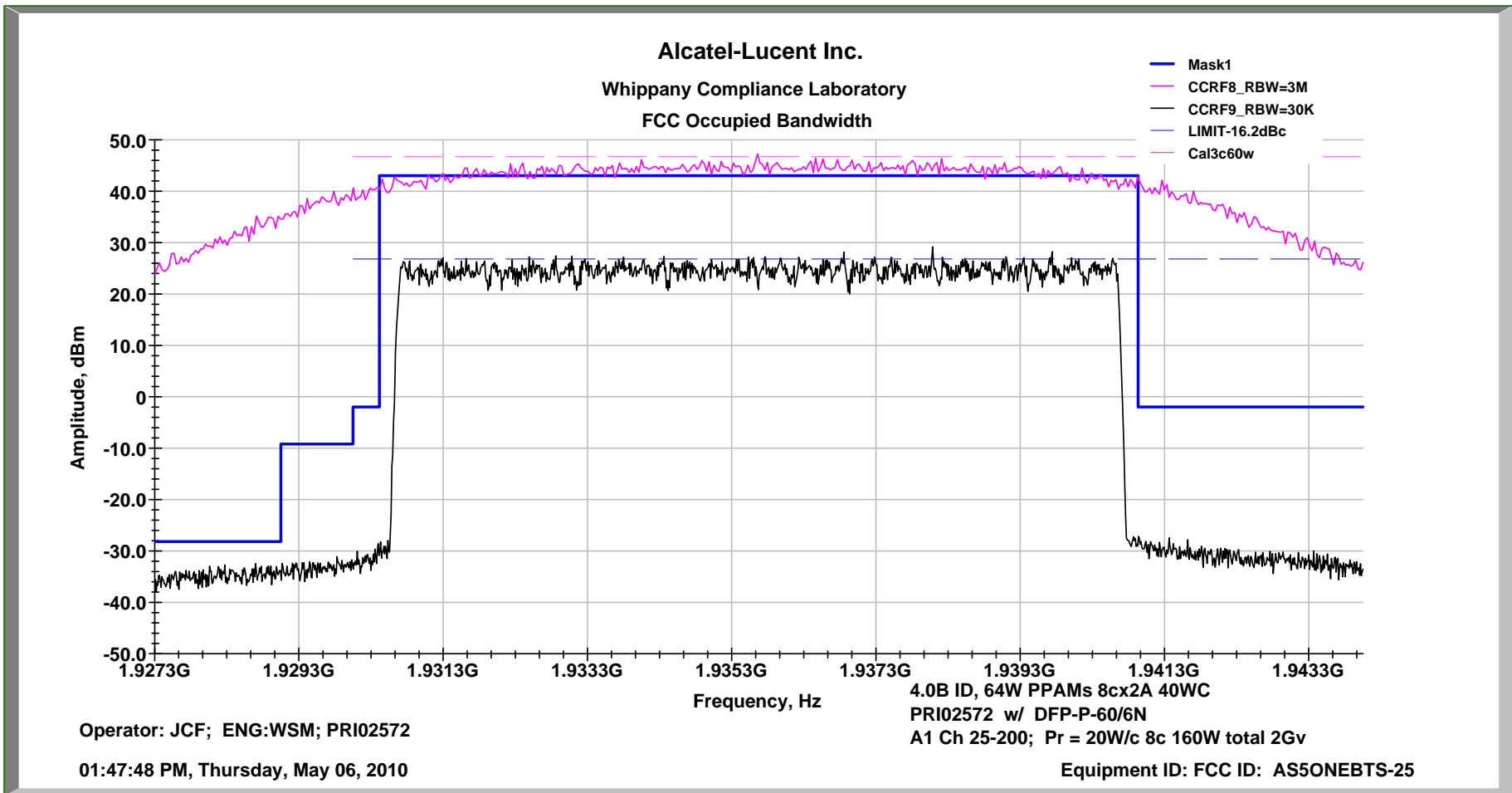
**In-band Inter-modulation    PCS Ch CG-1200 – 1275   P4PAM   4cx2A   2Gv   40W/c   160W Total**



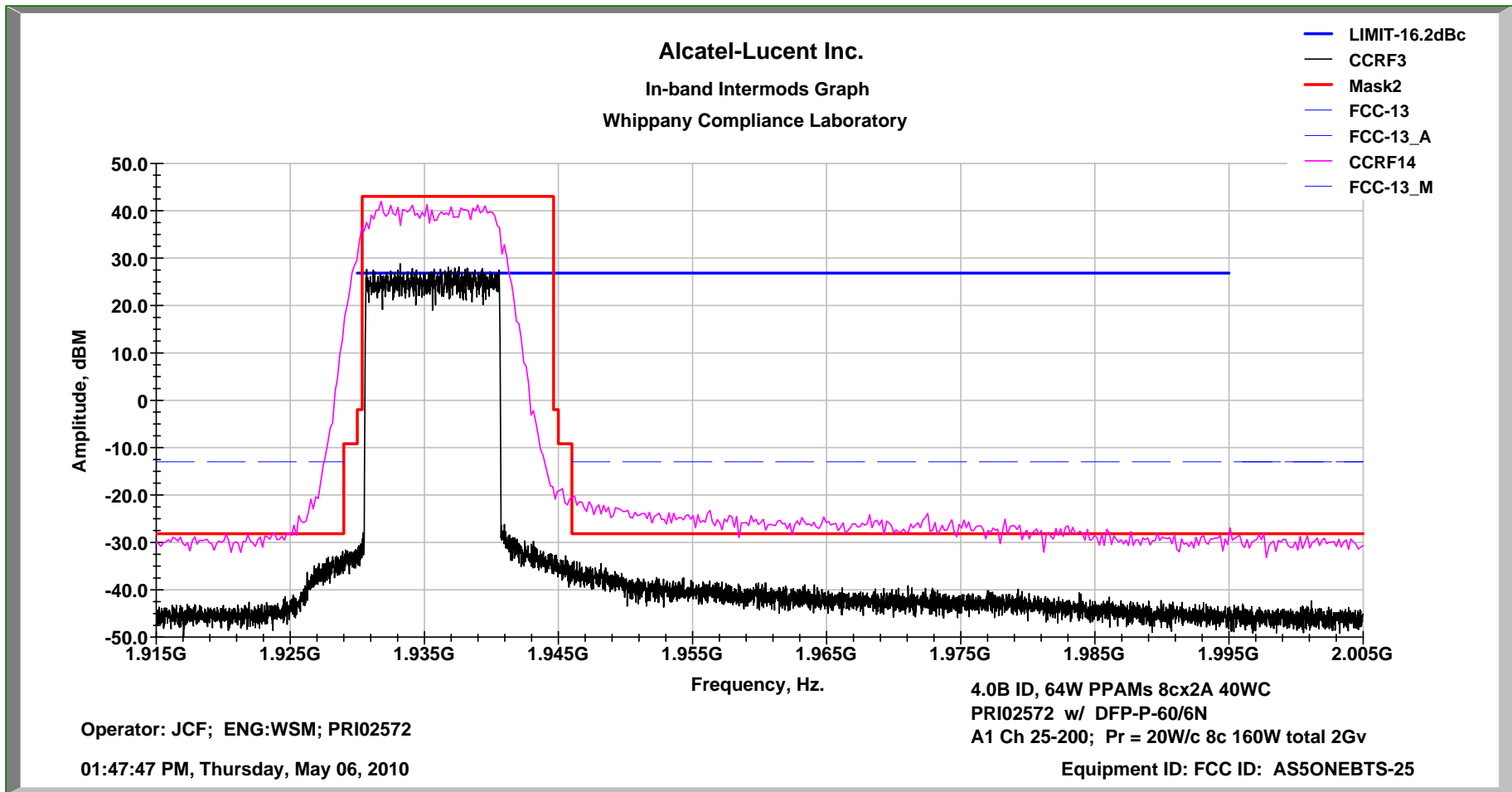
**Two Amplifier Eight Carrier  
80 W/Amp 160W Total  
Occupied Bandwidth Data  
PCS Blocks A through G  
Left side of Block, Right side of Block  
And  
PCS Band Intermodulation**

**8c x 2A 20W/c**

**Occupied Bandwidth      PCS Ch A1-25-200      8cx2A P4PAM      2Gv      20W/c      160W Total**



**In-band Inter-modulation    PCS Ch A1-25-200    8cx2A P4PAM    2Gv    20W/c    160W Total**



**Occupied Bandwidth**

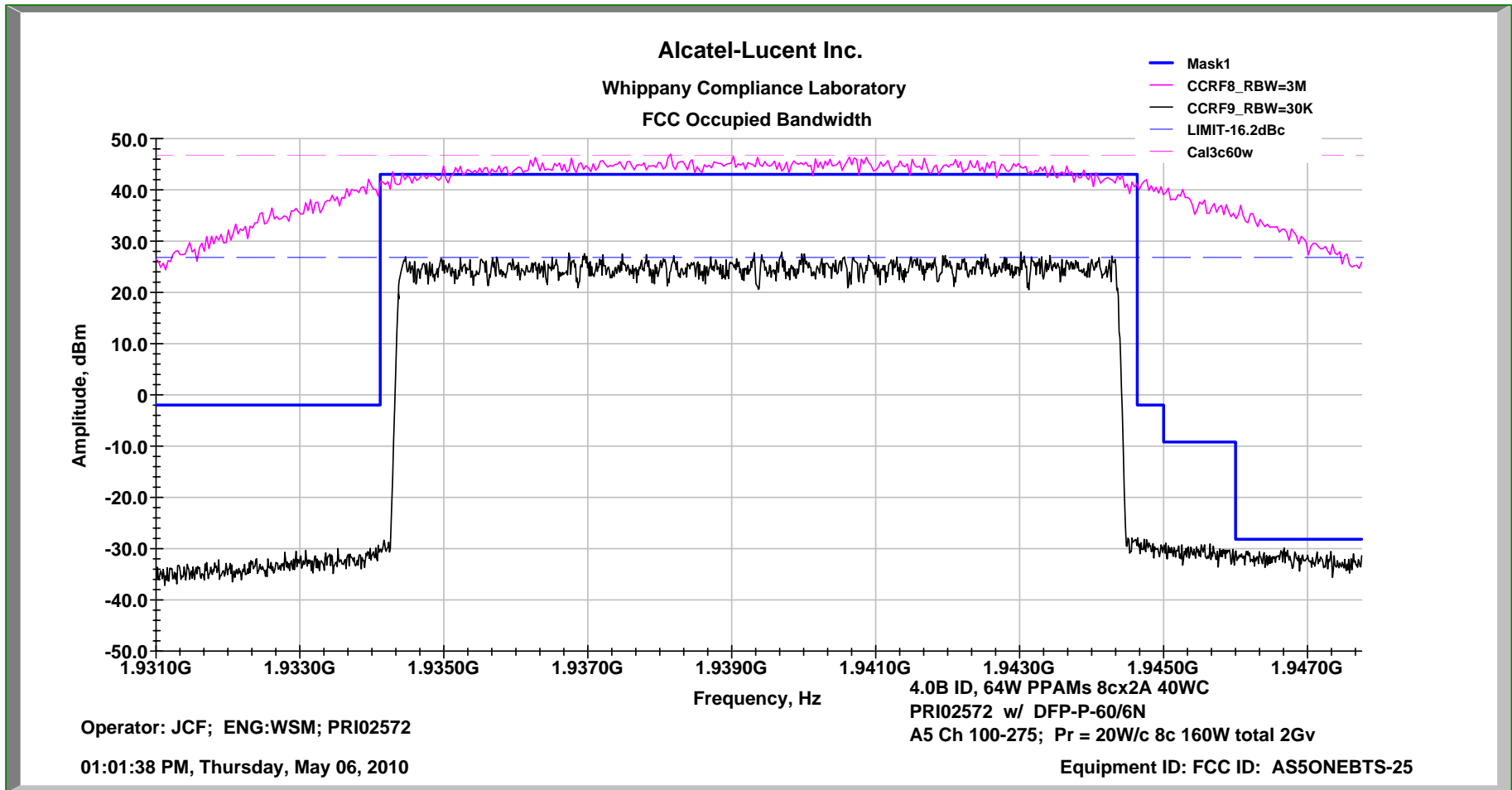
**PCS Ch A5-100-275**

**8cx2A P4PAM**

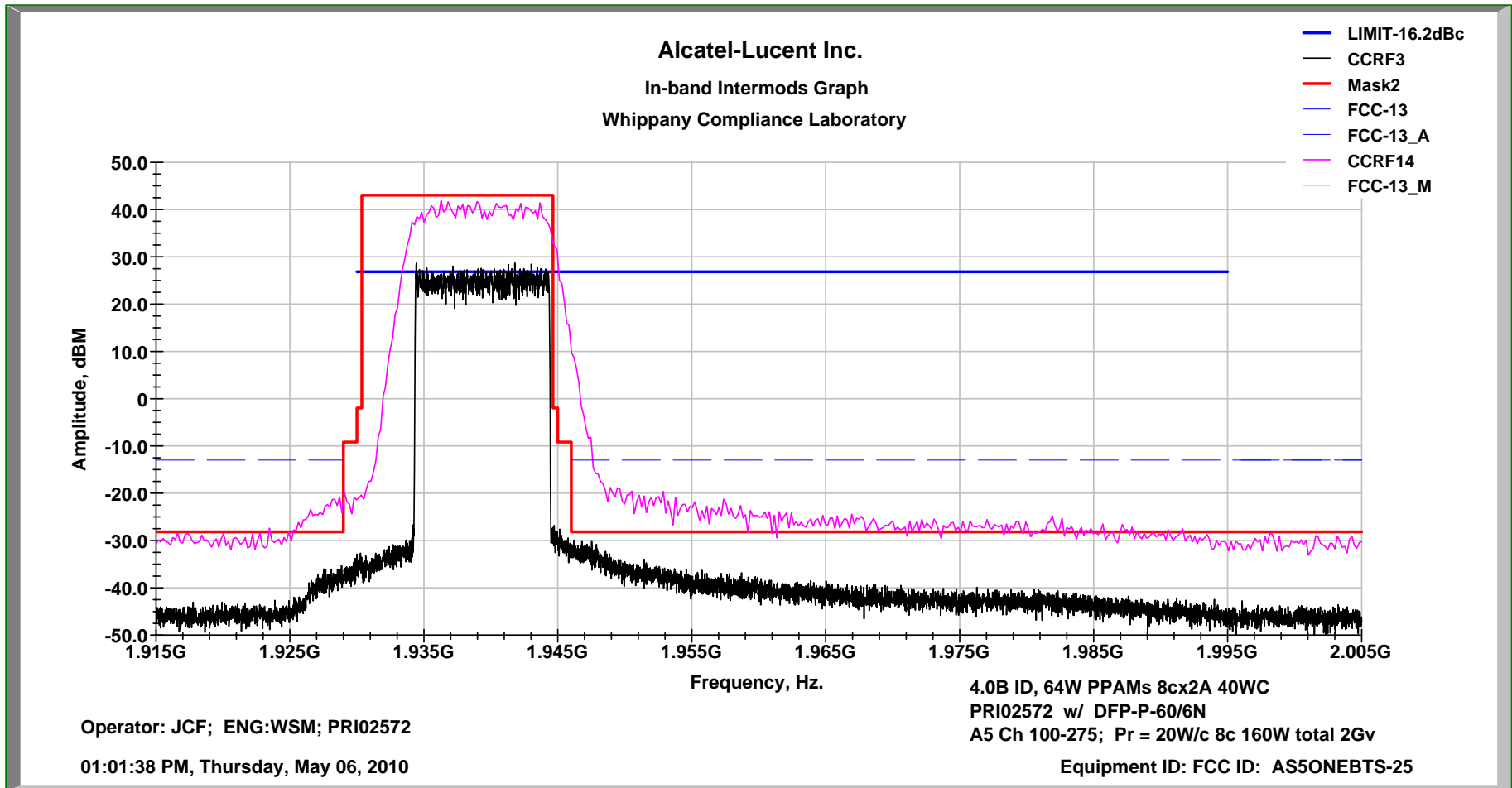
**2Gv**

**20W/c**

**160W Total**

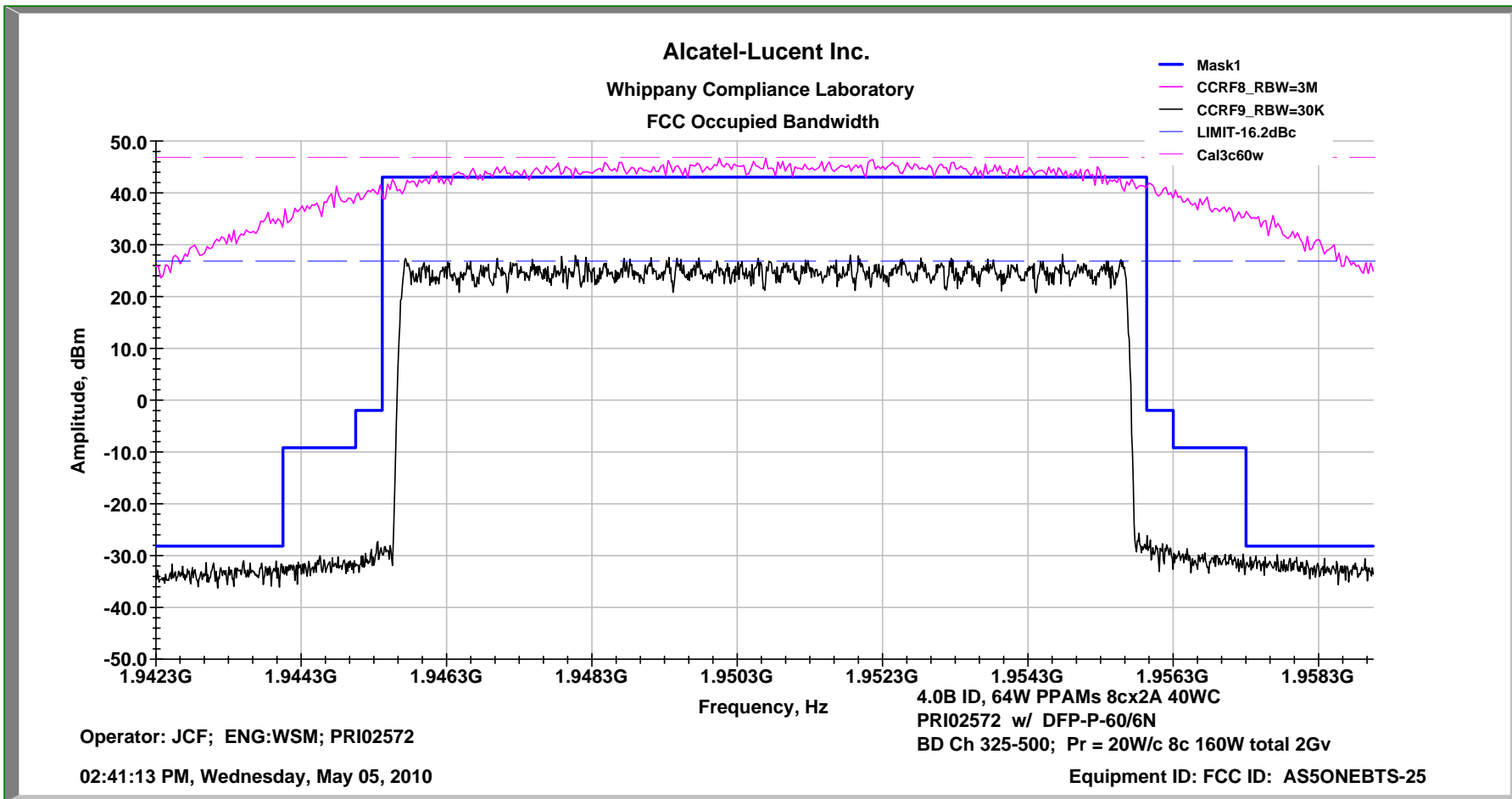


**In-band Inter-modulation    PCS Ch A5-100-275    8cx2A P4PAM    2Gv    20W/c    160W Total**

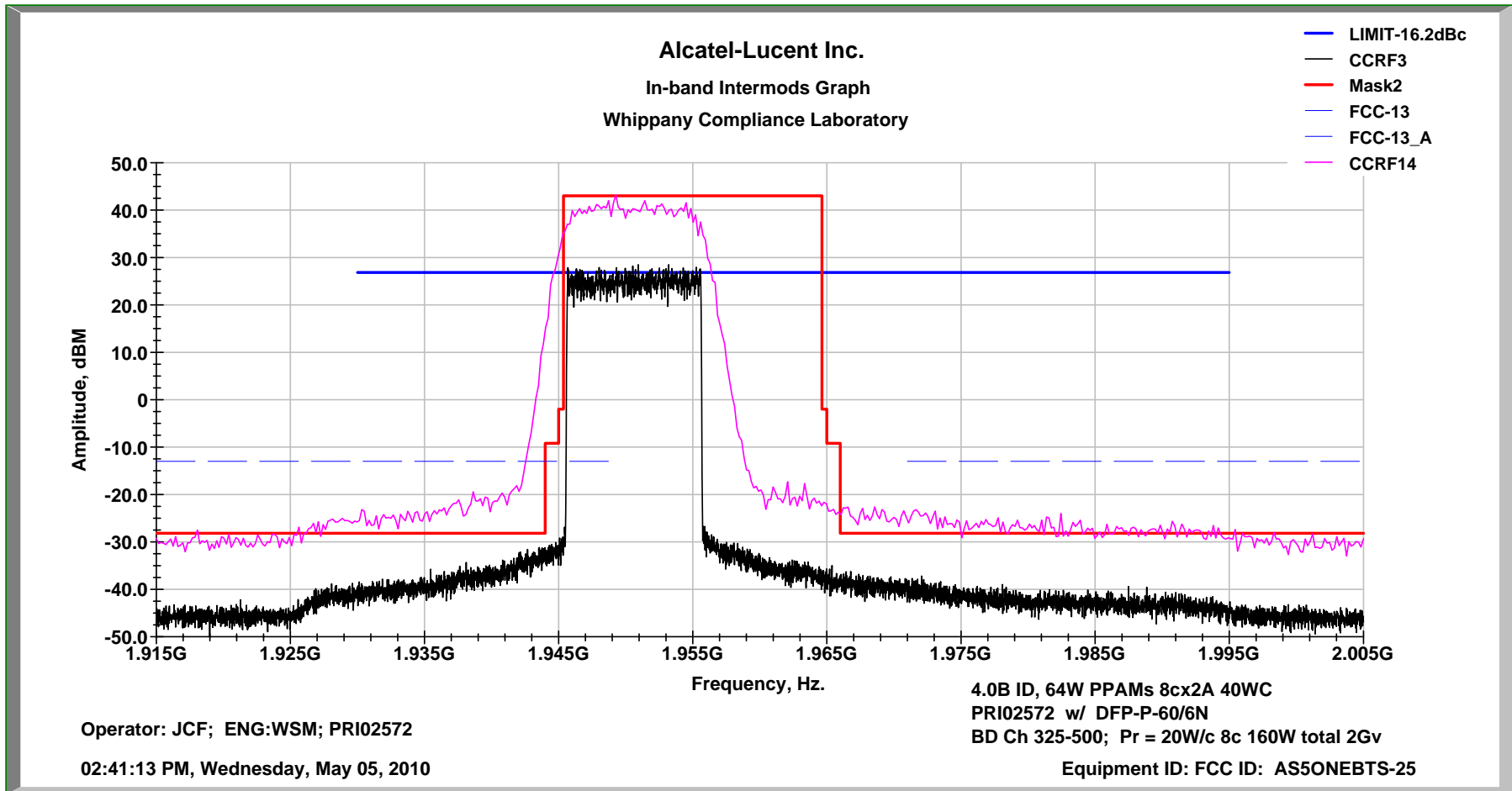




**Occupied Bandwidth      PCS Ch BD-325-500      8cx2A P4PAM      2Gv      20W/c      160W Total**



**In-band Inter-modulation    PCS Ch BD-325-500    8cx2A P4PAM    2Gv    20W/c    160W Total**



**Occupied Bandwidth**

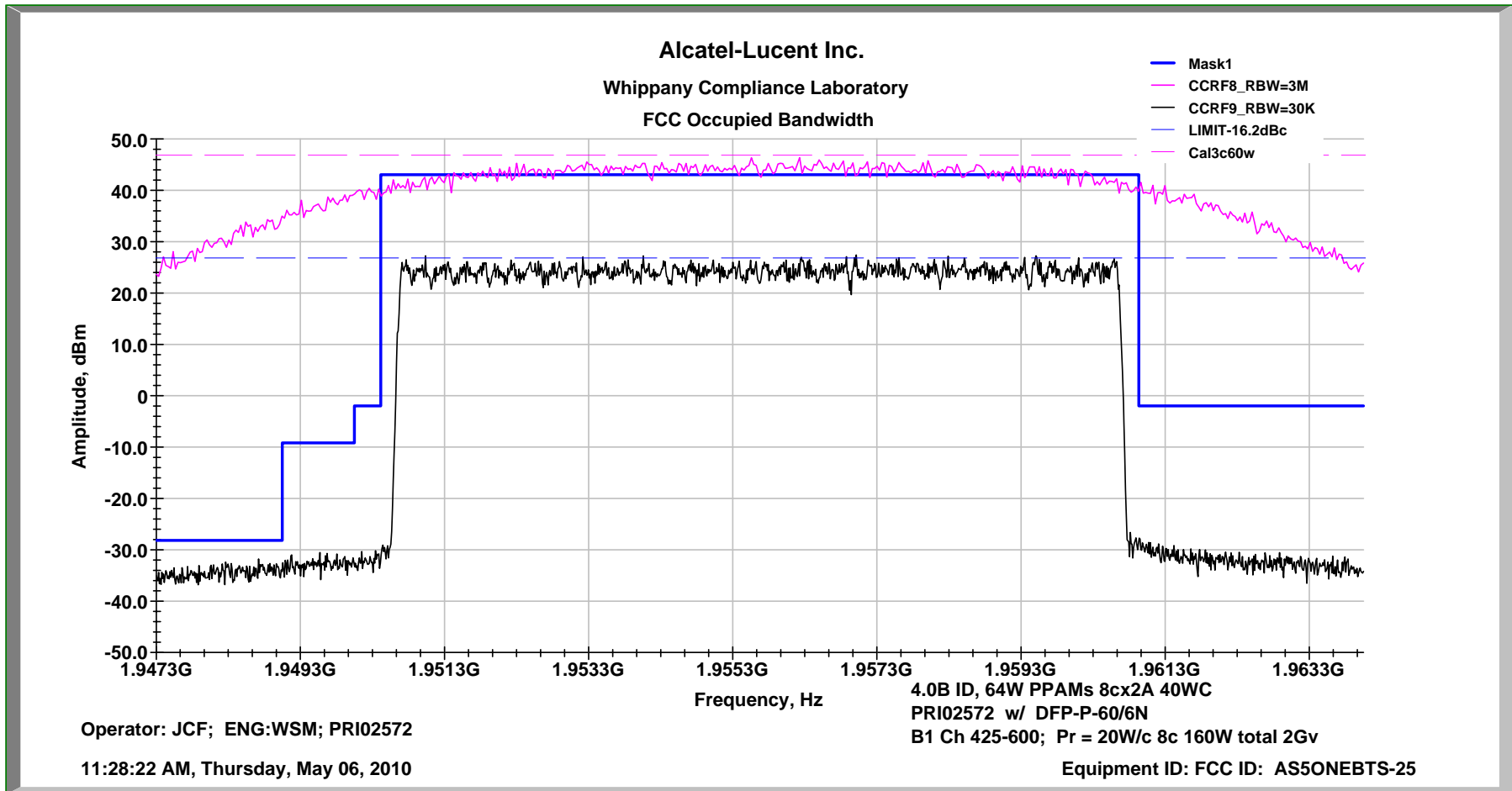
**PCS Ch B1 425-600**

**8cx2A P4PAM**

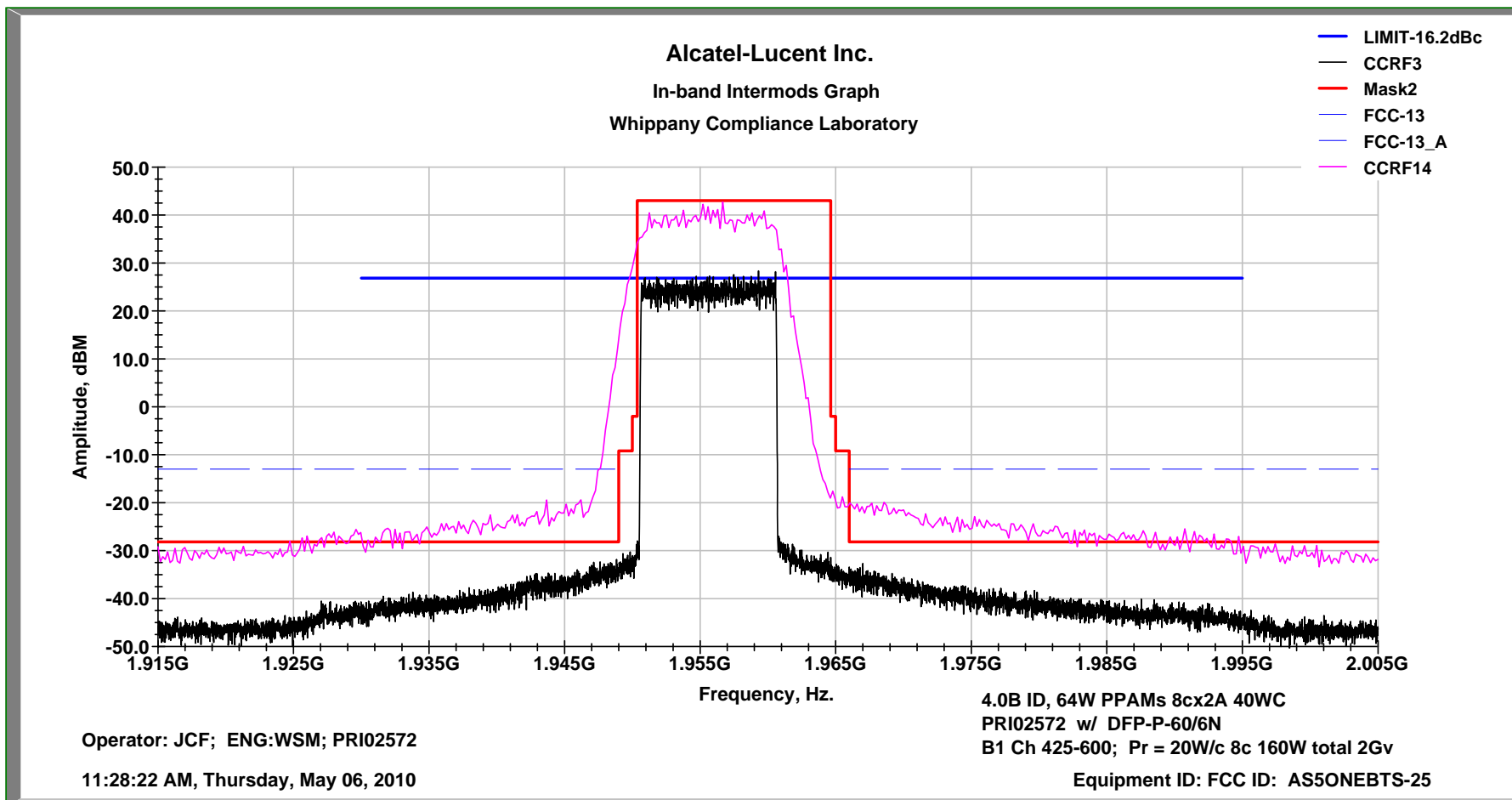
**2Gv**

**20W/c**

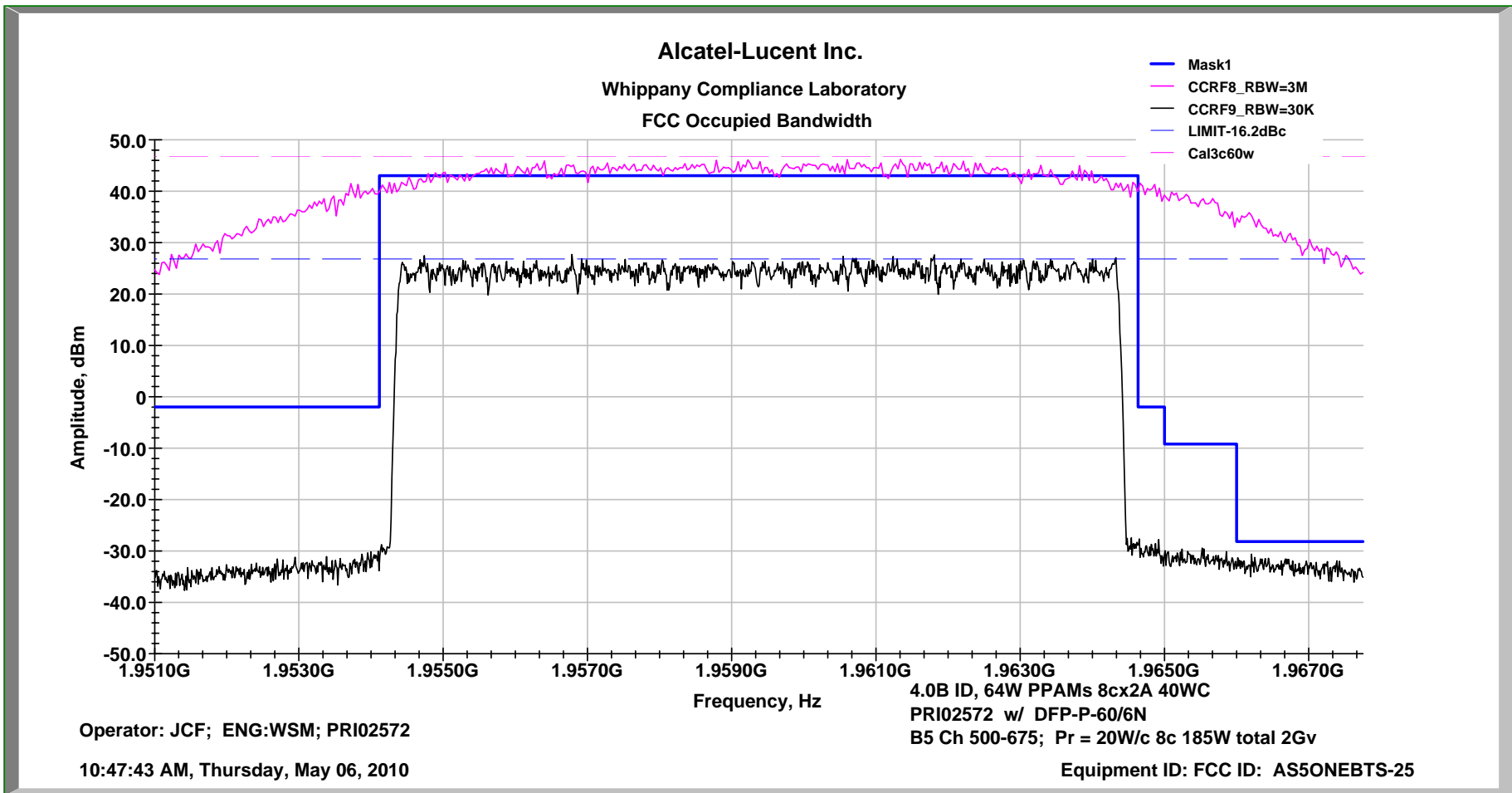
**160W Total**



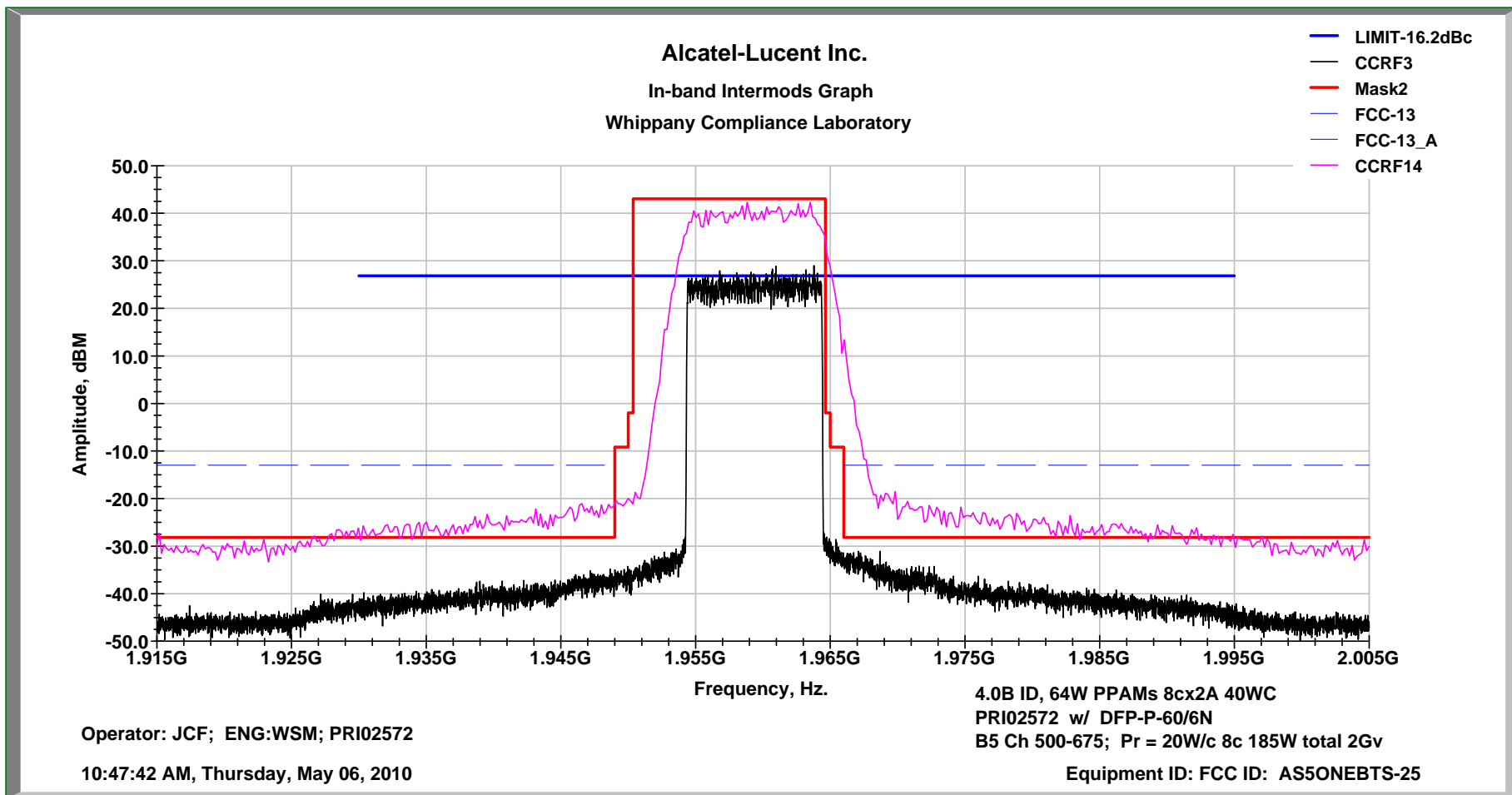
**In-band Inter-modulation    PCS Ch B1 425-600    8cx2A P4PAM    2Gv    20W/c    160W Total**



**Occupied Bandwidth      PCS Ch B5-500-675      8cx2A P4PAM      2Gv      20W/c      160W Total**

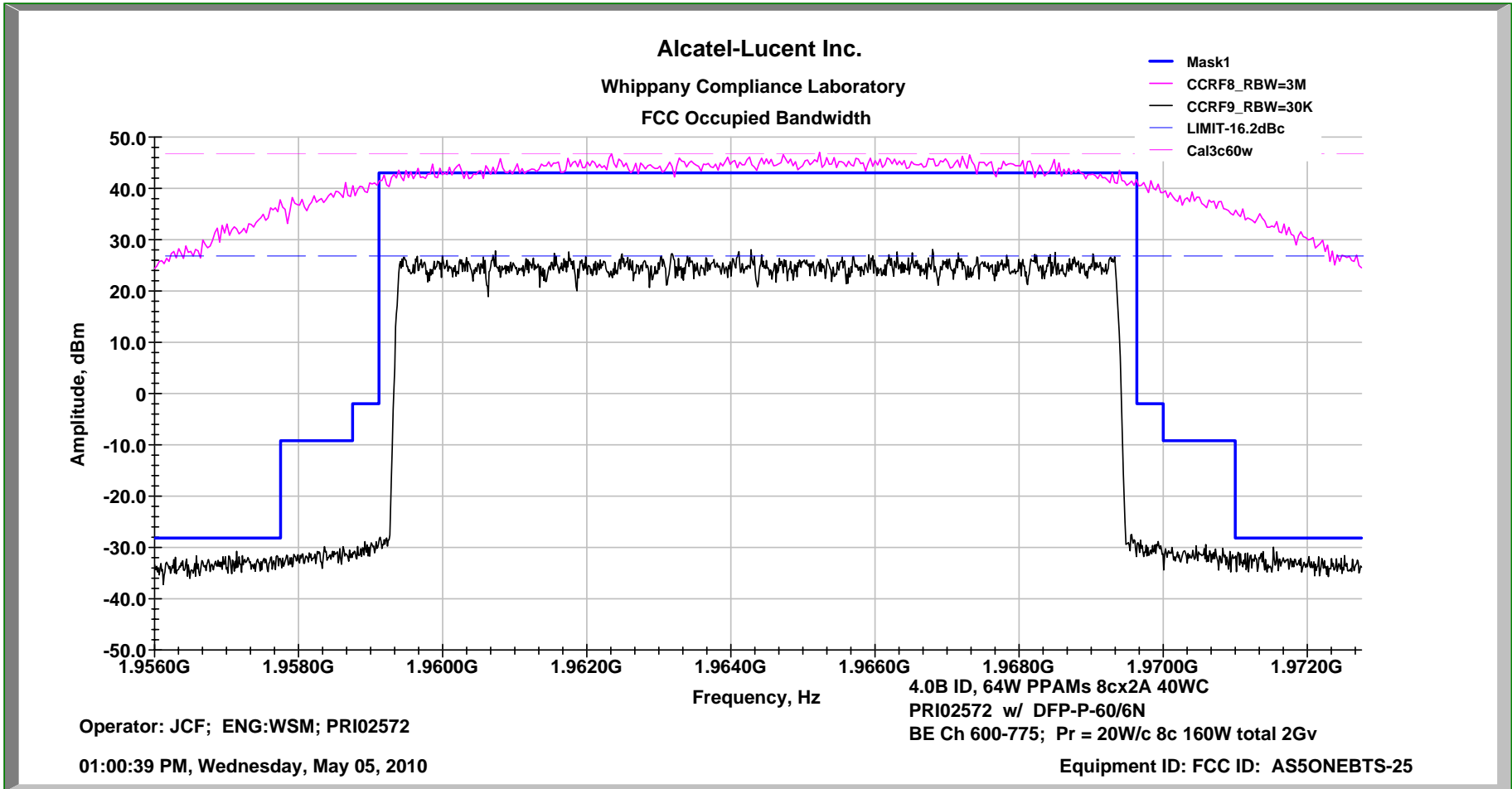


**In-band Inter-modulation    PCS Ch B5-500-675    8cx2A P4PAM    2Gv    20W/c    160W Total**

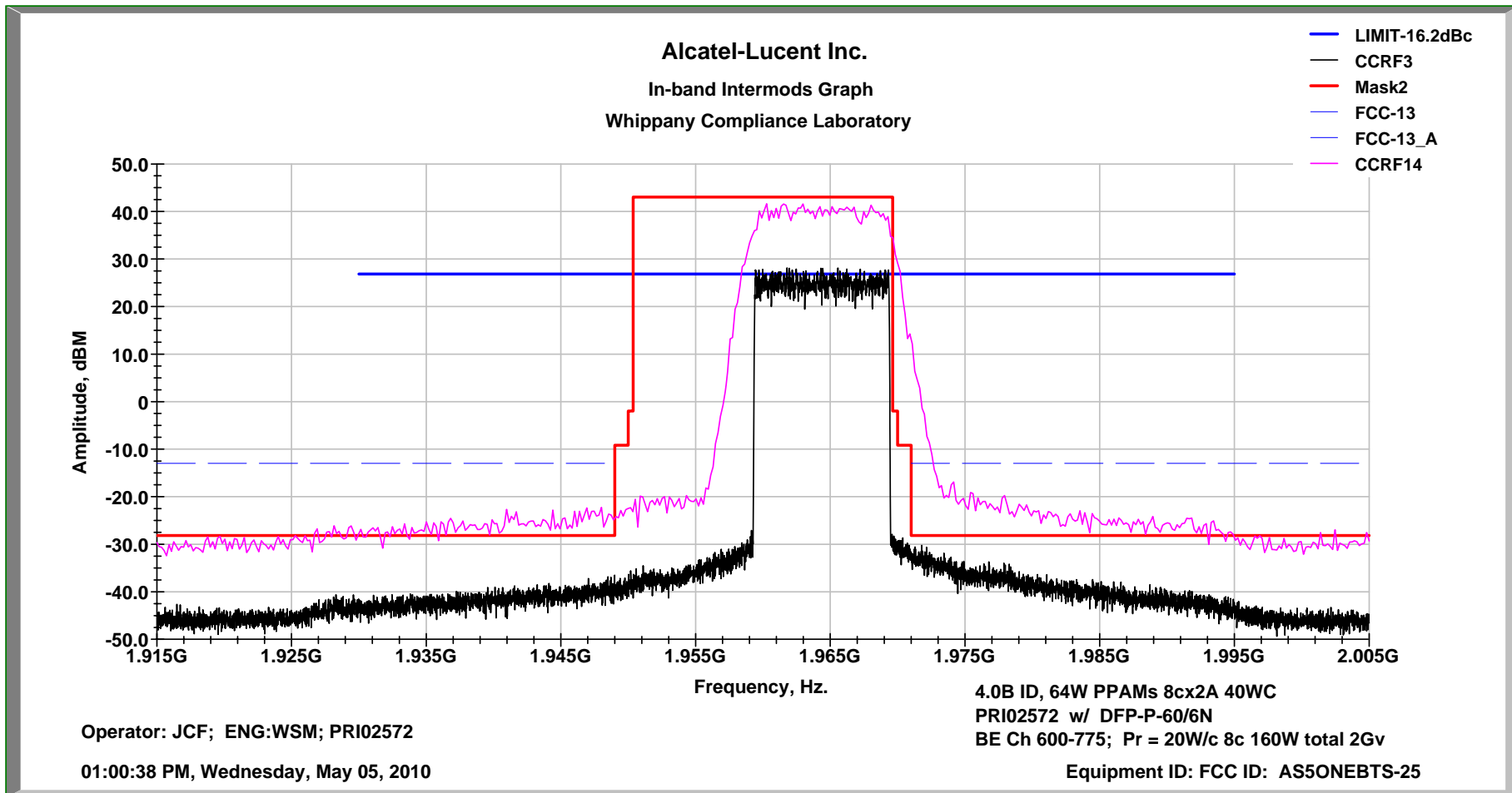


**Occupied Bandwidth**

**PCS Ch BE-600-775 8cx2A P4PAM 2Gv 20W/c 160W Total**



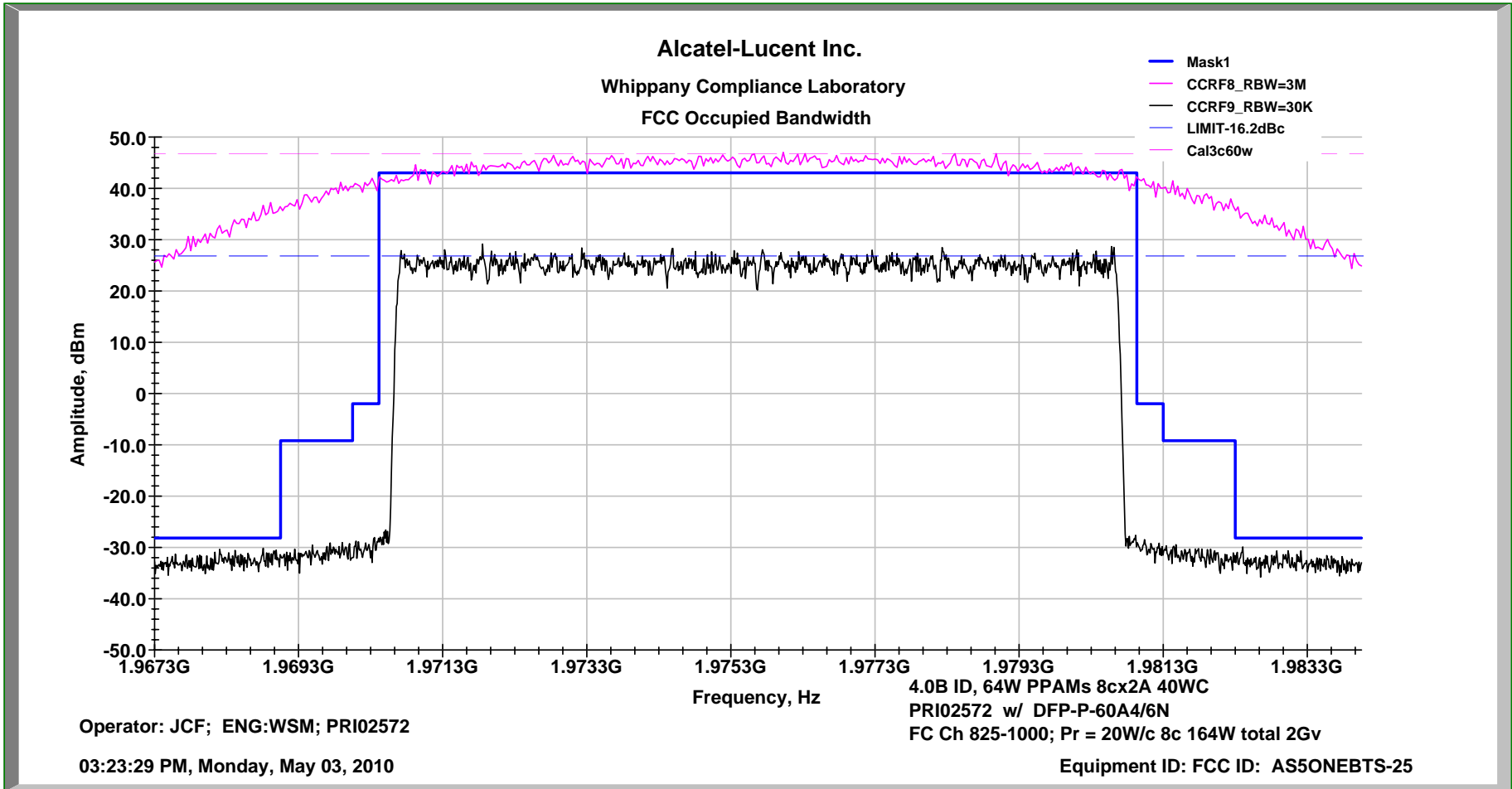
**In-band Inter-modulation    PCS Ch BE-600-775    8cx2A P4PAM    2Gv    20W/c    160W Total**



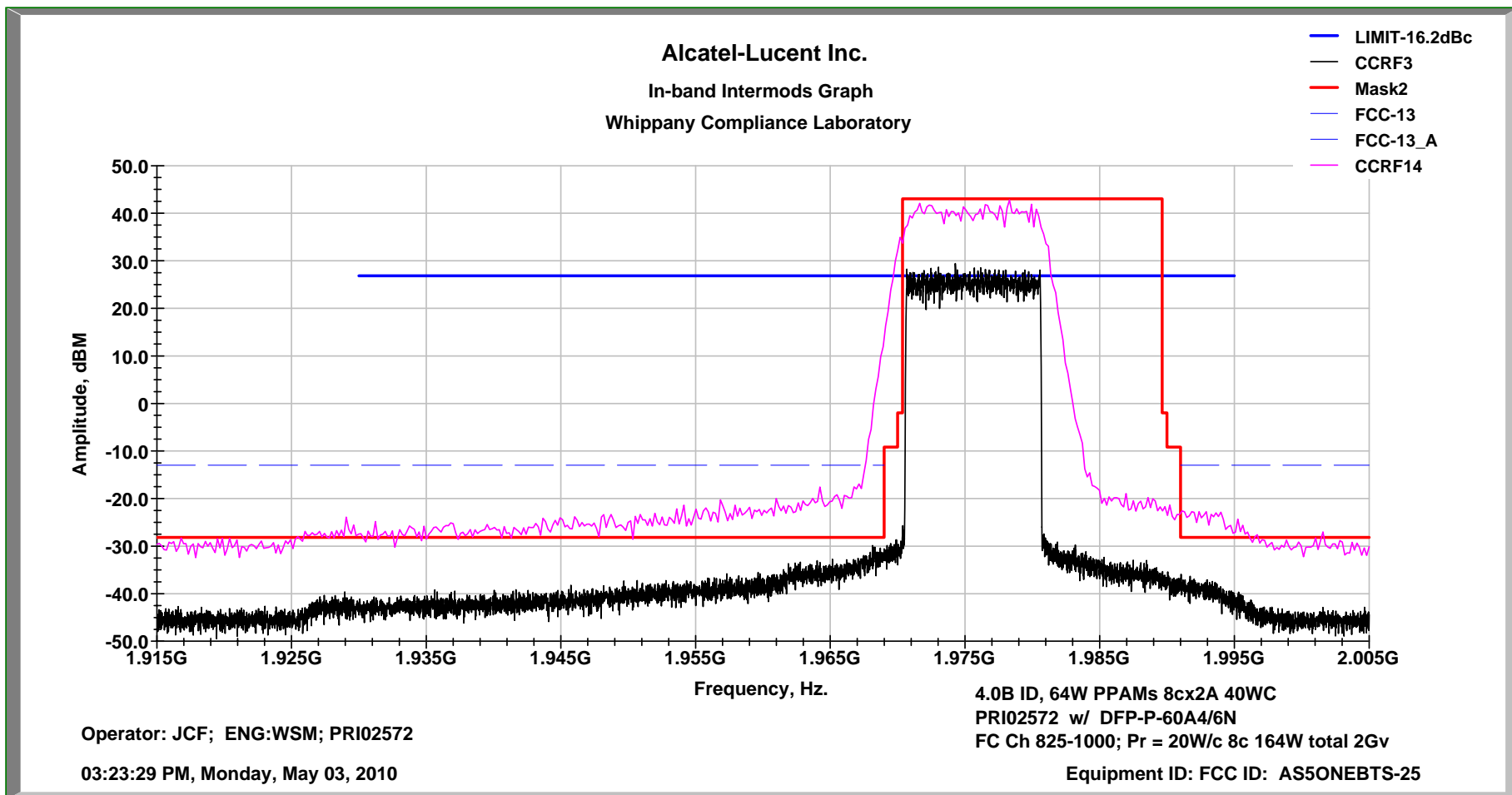


### Occupied Bandwidth

PCS Ch FC-825-1000 8cx2A P4PAM 2Gv 20W/c 160W Total

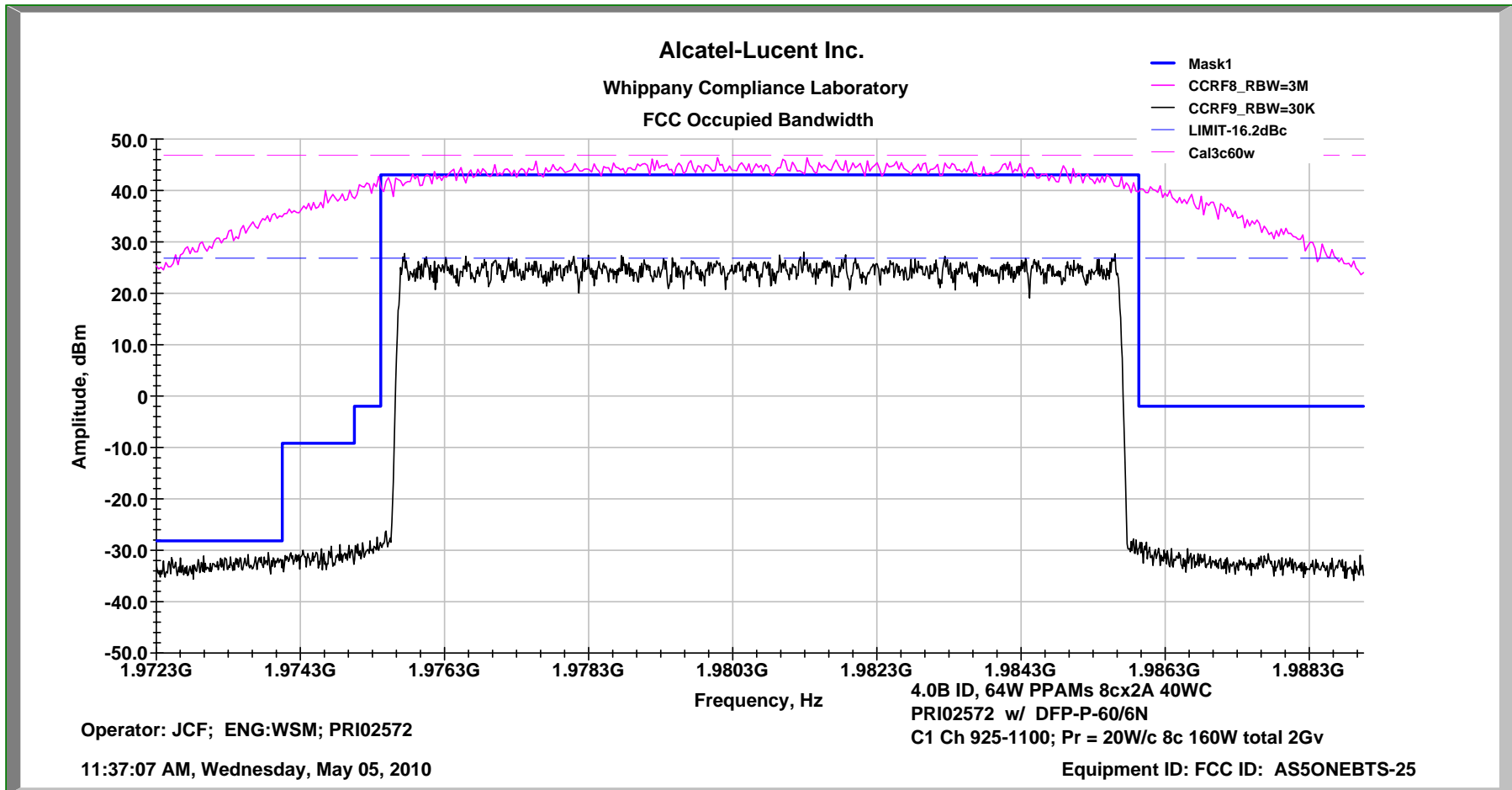


**In-band Inter-modulation    PCS Ch FC-825-1000    8cx2A P4PAM    2Gv    20W/c    160W Total**

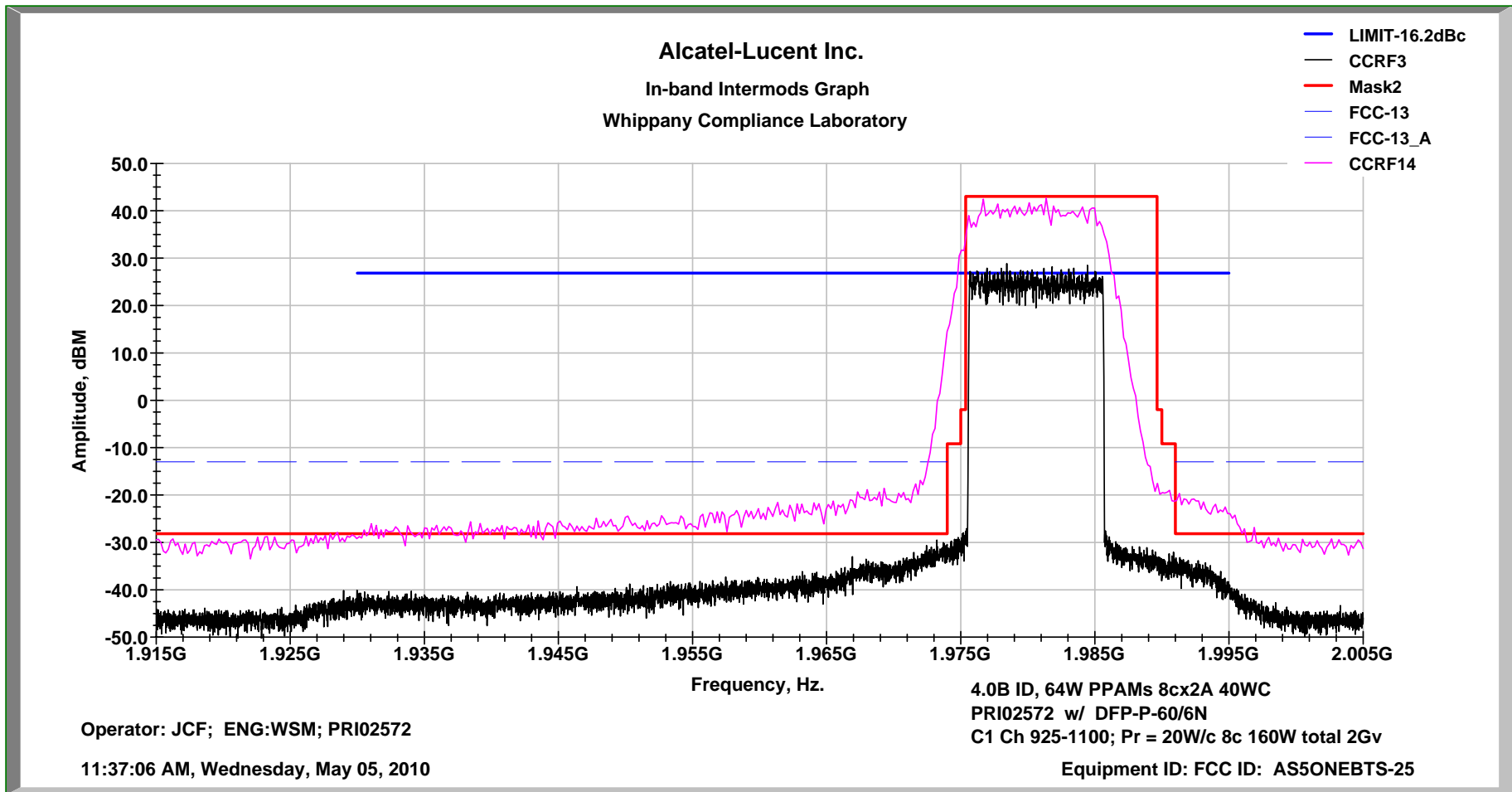


**Occupied Bandwidth**

**PCS Ch C1-925-1100 8cx2A P4PAM 2Gv 20W/c 160W Total**

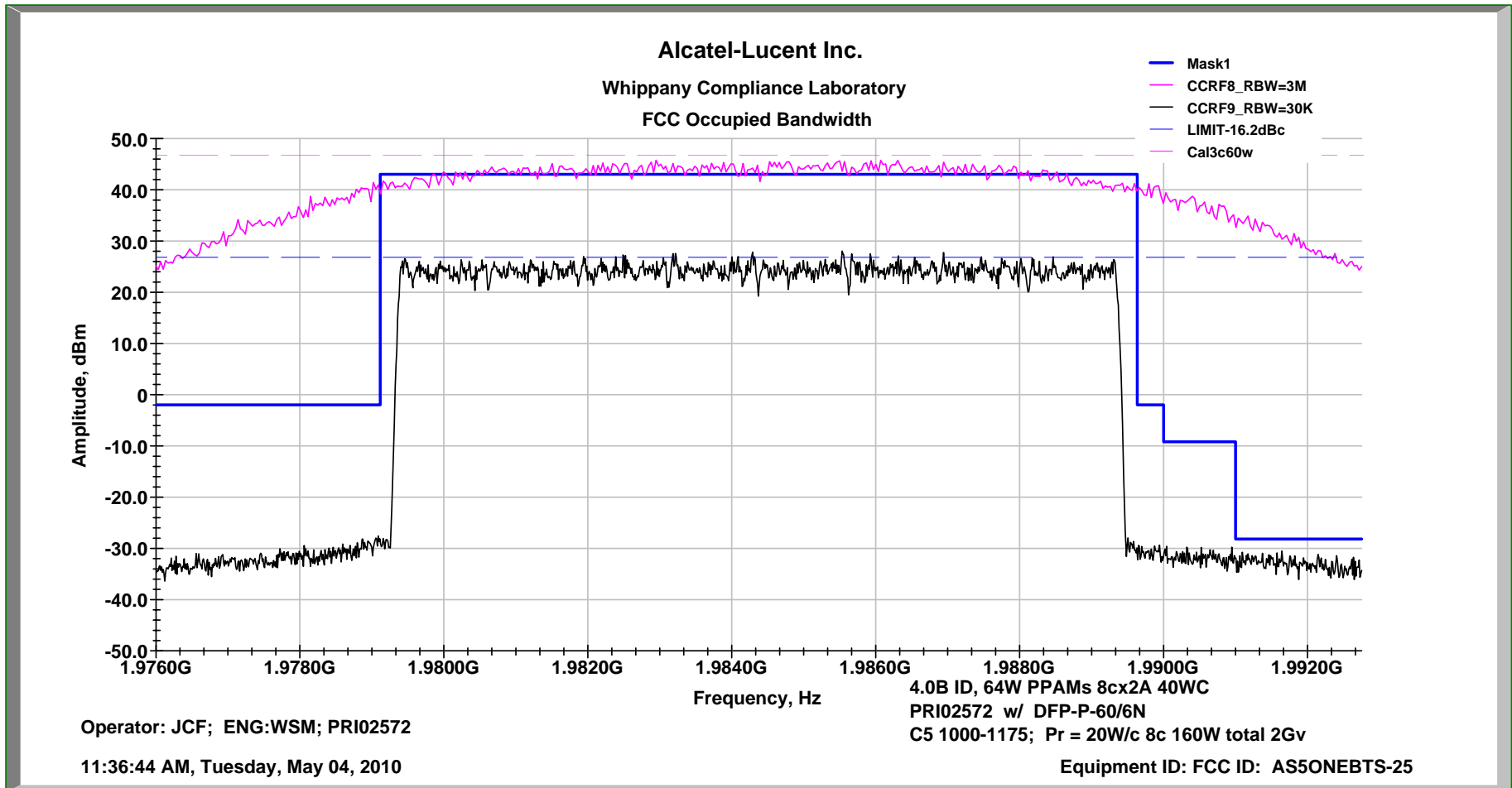


**In-band Inter-modulation    PCS Ch C1-925-1100    8cx2A P4PAM    2Gv    20W/c    160W Total**

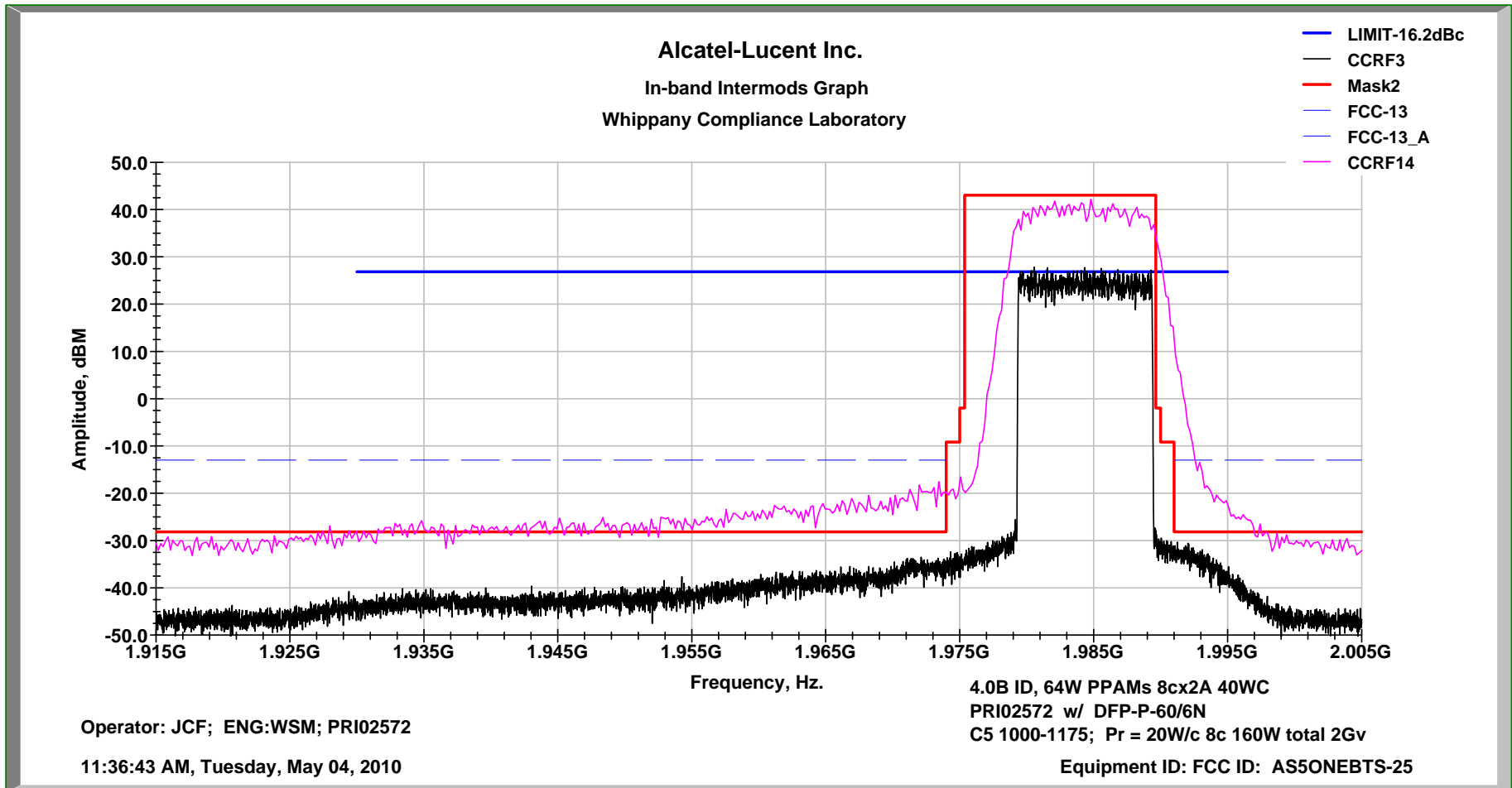


**Occupied Bandwidth**

**PCS Ch C5-1000-1175 8cx2A P4PAM 2Gv 20W/c 160W Total**

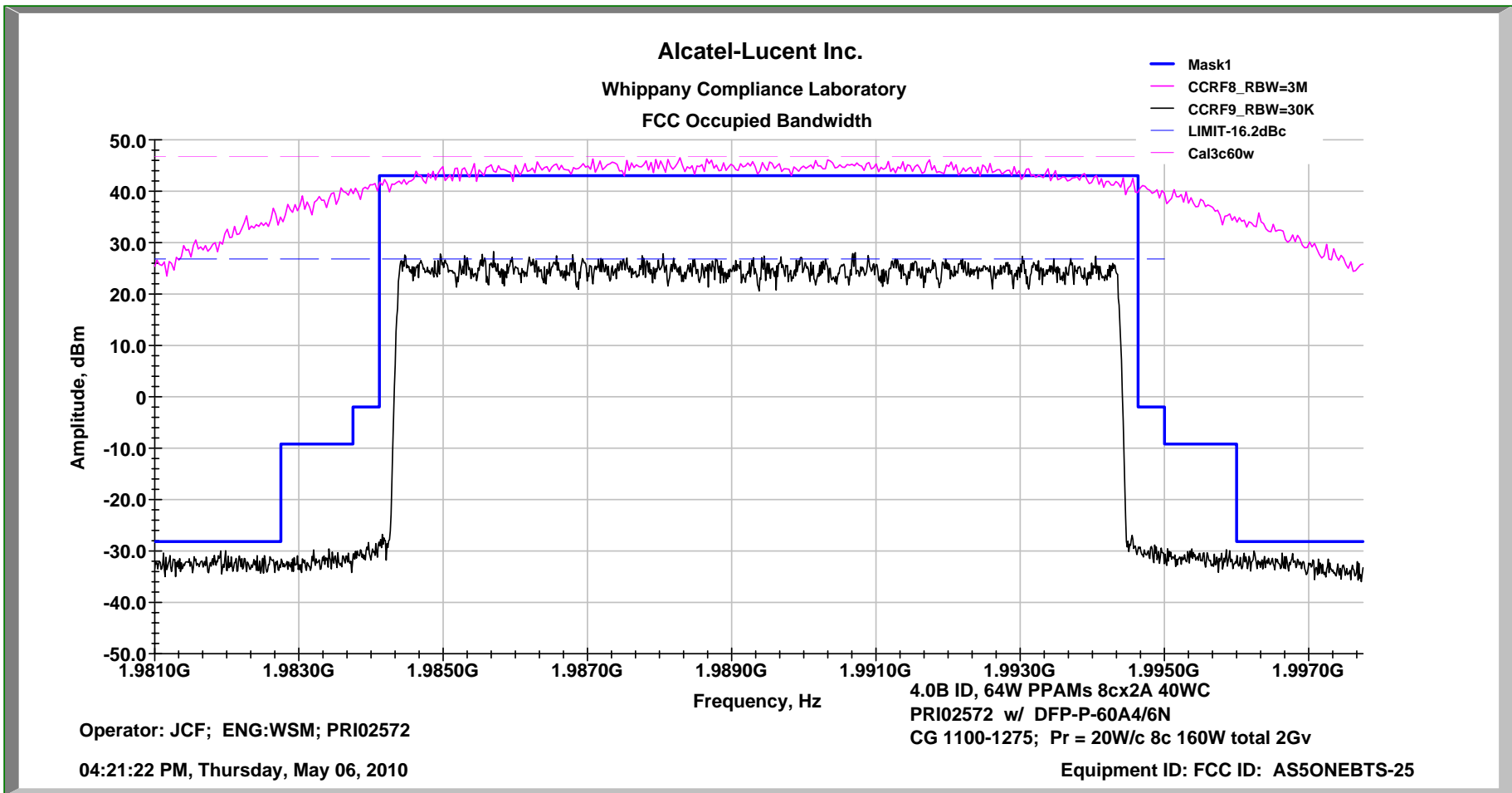


**In-band Inter-modulation    PCS Ch C5-1000-1175   8cx2A P4PAM   2Gv   20W/c   160W Total**

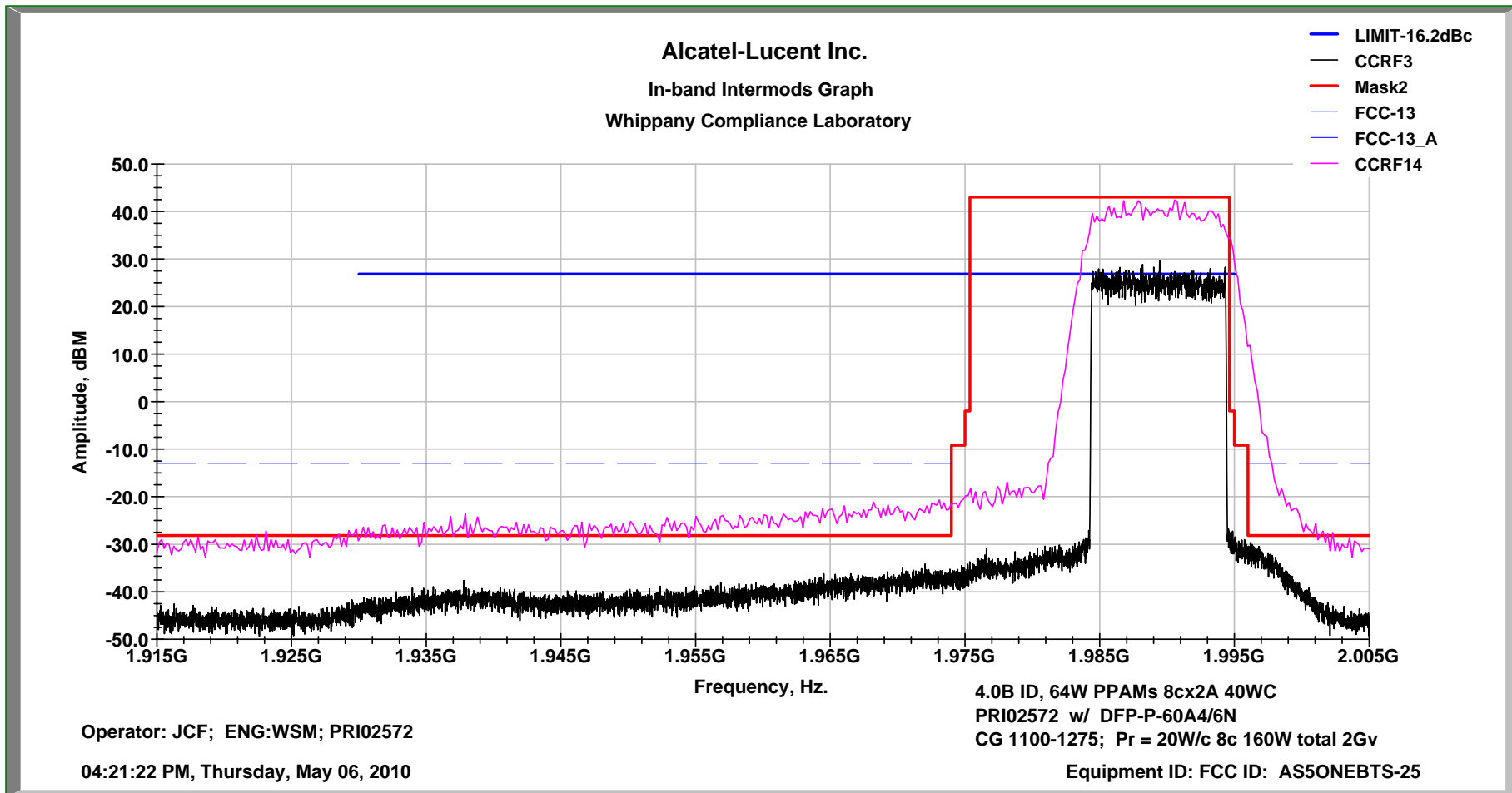


Occupied Bandwidth

PCS Ch CG-1100-1275 8cx2A P4PAM 2Gv 20W/c 160W Total



**In-band Inter-modulation    PCS Ch CG-1100-1275 8cx2A P4PAM    2Gv 20W/c 160W Total**





**Exhibit 15: SPURIOUS EMISSIONS AT ANTENNA TERMINAL**

**Section 2.1051 Spurious Emissions at Antenna Terminals**

Spurious Emissions at the antenna terminals were investigated over the frequency range of 10 MHz to 20 GHz which is beyond the 10th harmonic of the carrier frequency. The RF output from the transmitter was reduced, to an amplitude usable by the spectrum analyzer, by use of a broadband attenuator. The complete RF test path was calibrated over the 10 MHz-20 GHz range. The RF power level was measured and monitored prior to and during the test via the test setup in Figure 15A. The spurious measurements were made using an automated test system. The test system consists of a Rohde & Schwarz FSEM30 Spectrum Analyzer (or ESIB Test Receiver), a PC based computer test controller, calibrated test hardware and a computer software program to acquire the test data. This system allows measurement and presentation of the data in an accurate and compact form for FCC review. The volume of collected data is greater than  $2 \times 10^5$  data points over the frequency range of 10 MHz to 20 GHz.

The required emission limitation specified in Section 24.238 of the Code was applied to these tests. Based upon the criterion given in Section 24.238 of the Code and as developed in Exhibit 14, the required emission limit is -13 dBm when measured with a resolution bandwidth of 1 MHz. The measurements of the spurious signals were therefore made using a resolution bandwidth of 1 MHz. All spurious and harmonics of the CDMA Carrier was also shown to be lower than -13 dBm limit.

The carrier signal shown on these plots was measured at a resolution Bandwidths of 3 MHz. This was done so that the carrier plot correctly and accurately depicts the carrier output power in relation to the spurious signals and the defined limit.

In order to adequately evaluate performance the worst case modulation factors of 2G Voice ( vs. 3G1X or 3G1X-EV-DO) were used from the governing documents. Thus, the applied signal, from a **PCS P4PAM EDPD Transceiver System**, met the recommended characteristics per "**Table 6.5.2-1 Base Station Test Model, Nominal**" from **3GPP2 C.S0010-C v2.0, 24 February 2006**, Recommended Minimum Performance Standards for cdma2000 Spread Spectrum Base Stations, as defined below in table 15.1.

Type	Number of Channels	Fraction of Power (Linear)	Fraction of Power (dB)	Comments
Forward Pilot	1	0.2000	-7.0	Code channel $W_0^{64}$
Sync	1	0.0471	-13.3	Code channel $W_{32}^{64}$ ; always 1/8 rate
Paging	1	0.1882	-7.3	Code channel $W_1^{64}$ ; full rate only
Traffic	M = 37	$0.5647/M$ = 0.015262	-2.48 - 10 log(M) = -18.1620	Variable Walsh assignments, full rate only

**TABLE 15.1 Base Station Test Model, Nominal for Main Path**

Type	Number of Channels	Fraction of Power (Linear)	Fraction of Power (dB)	Comments
Transmit Diversity Pilot	1	0.2000	-7.0	Code channel $W_{16}^{128}$
Traffic	M = 37	$0.5647/M$ = 0.015262	-2.48 - 10 log(M) = -18.1620	Variable Walsh code channel assignments, full rate only

**TABLE 15.2 Base Station Test Model, Nominal for Transmit Diversity Path**

**Exhibit 12** *continued*

The FCC limits contained in **47CFR 24.238 1-Oct-2007** were followed along with the minimum standard presented in **3GPP2 C.S0010-C v2.0, 24 February 2006**. Where combinational measurements of 3G1x-EV-DO are made along with the 2 GV configuration above the applied signal were based upon the 3GPP2 TSG-C.S0032-1 titled "Recommended Minimum Performance Standards for CDMA2000 High Rate Packet Data Access Network ". Section 3.1.2.4 Limitations on Emissions. This standard covers the emissions situation except that we use the maximum 25 MAC full traffic configuration as the standard.

**Test Results Summary:**

Conducted Spurious measurements were performed for the one and two amplifier multi carrier channel configurations at each edge of PCS Block for which the **PCS P4PAM EDPD Transceiver System** supports operation. Conducted Transmit Spurious measurements were performed as part of the test profile for Occupied Bandwidth. Every PCS Block Edge measurements configuration therefore included a Conducted Transmit Spurious measurements as documented in Table 15.2.

**Conclusion**

The attached spectral plots are representative of the Conducted Spurious compliance performance of the **PCS P4PAM EDPD Transceiver System**. The compliance for all of the representative transmit configurations are documented in Table 15.2. This Table lists PCS Blocks/ Channels tested the Channel configuration and the status of the performance. The performance data, charts and tables all show that there are no "Out of Block" harmonics or spurious emissions above the applicable limit of -13 dBm. The attached table and sample data plots document the results. This demonstrates that the **PCS P4PAM EDPD Transceiver System**. / **FCC ID: AS5ONEBTS-25**, the subject of this application, complies with Sections 2.1053, 24.238 and 2.1051 of the Rules. W. Steve Majkowski

Exhibit 15 *continued*

PCS - Block	PCS -Channels		Number of carriers	Power per Carrier, W/c	Number of Amplifiers	Total Power Watts	Results Conducted Spurious Emissions
<b>Single amplifier 2 Carrier Configuration</b>							
A	25-50	250-275	2	40	1	80	Compliant
D	325-350	350-375	2	40	1	80	Compliant
B	425-450	650-675	2	40	1	80	Compliant
E	725-750	750-775	2	40	1	80	Compliant
F	825-850	850-875	2	40	1	80	Compliant
C	925-950	1150-1175	2	40	1	80	Compliant
G	1225-1250	1250-1275	2	40	1	80	Compliant
<b>Single amplifier 4 Carrier Configuration</b>							
A	25-100	200-275	4	20	1	80	Compliant
D	325-400		4	20	1	80	Compliant
B	425-500	600-675	4	20	1	80	Compliant
E	700-775		4	20	1	80	Compliant
F	825-900		4	20	1	80	Compliant
C	925-1000	1100-1175	4	20	1	80	Compliant
G	1200-1275		4	20	1	80	Compliant
<b>Two amplifier 4 Carrier Configuration</b>							
A	25-100	200-275	4	40	2	160	Compliant
AD	325-400		4	40	2	160	Compliant
B	425-500	600-675	4	40	2	160	Compliant
BE	700-775		4	40	2	160	Compliant
FC	825-900		4	40	2	160	Compliant
C	925-1000	1100-1175	4	40	2	160	Compliant
CG	1200-1275		4	40	2	160	Compliant
<b>Two amplifier 8 Carrier Configuration</b>							
A	25-100	200-275	8	20	2	160	Compliant
AD	325-400		8	20	2	160	Compliant
B	425-500	600-675	8	20	2	160	Compliant
BE	700-775		8	20	2	160	Compliant
FC	825-900		8	20	2	160	Compliant
C	925-1000	1100-1175	8	20	2	160	Compliant
CG	1200-1275		8	20	2	160	Compliant

**TABLE 15.2 PCS Antenna Port Conducted Spurious Compliance Tabulation**



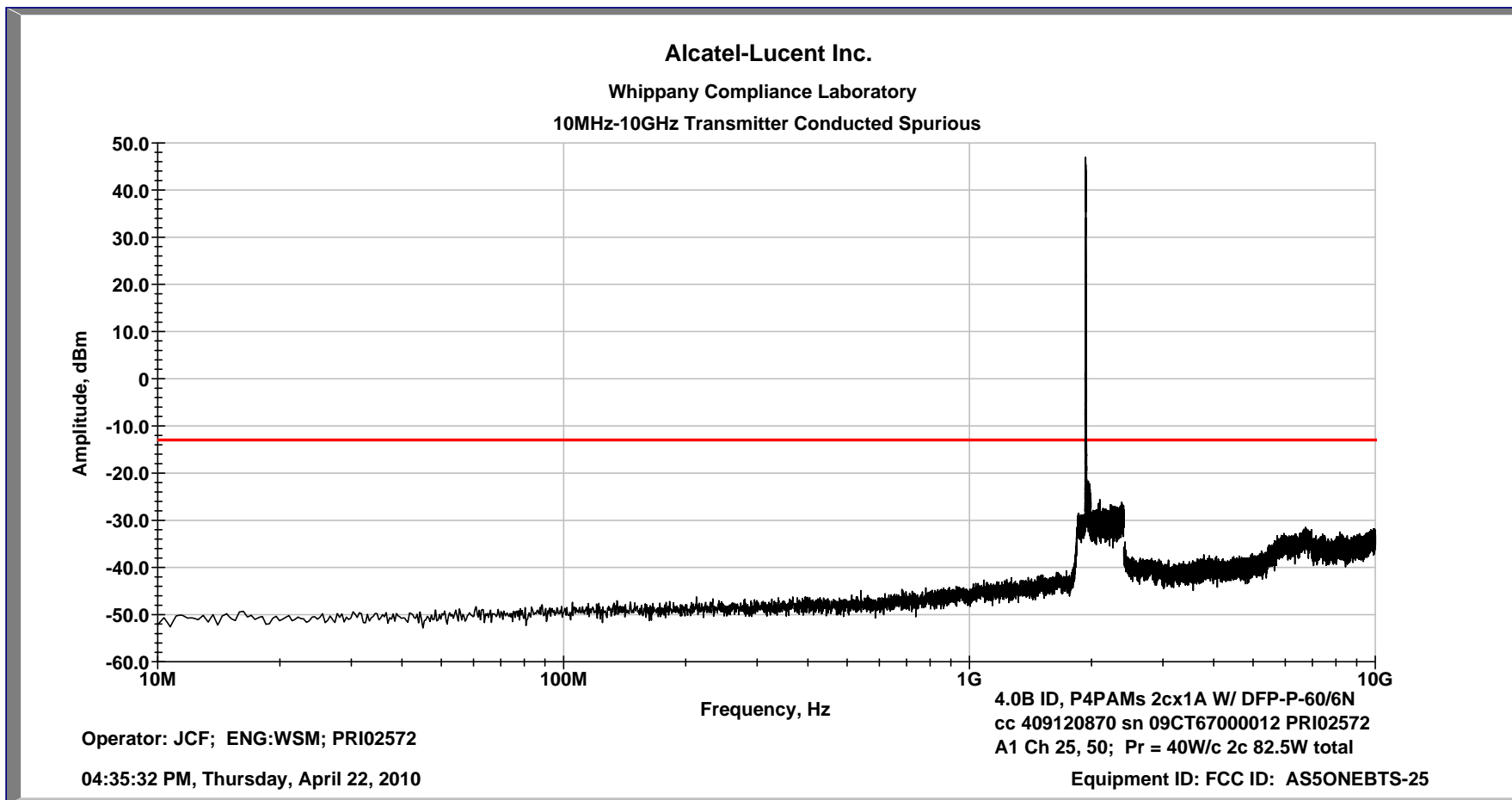


**Sample Transmitter Measurements  
of  
Conducted Spurious Emissions  
for  
Alcatel-Lucent Inc.  
PCS P4PAM EDPD Transceiver System  
FCC ID: AS50NEBTS-25  
with  
9228 Base Station Macro  
One and Two Amplifier Configurations  
CDMA Operation at  
80Wper Amplifier**

W. Steve Majkowski NCE  
CDMA Certification Lead  
Whippany FCC Compliance Laboratory  
Alcatel-Lucent.  
Lab: 973-386-2135  
[majkowski@alcatel-lucent.com](mailto:majkowski@alcatel-lucent.com)

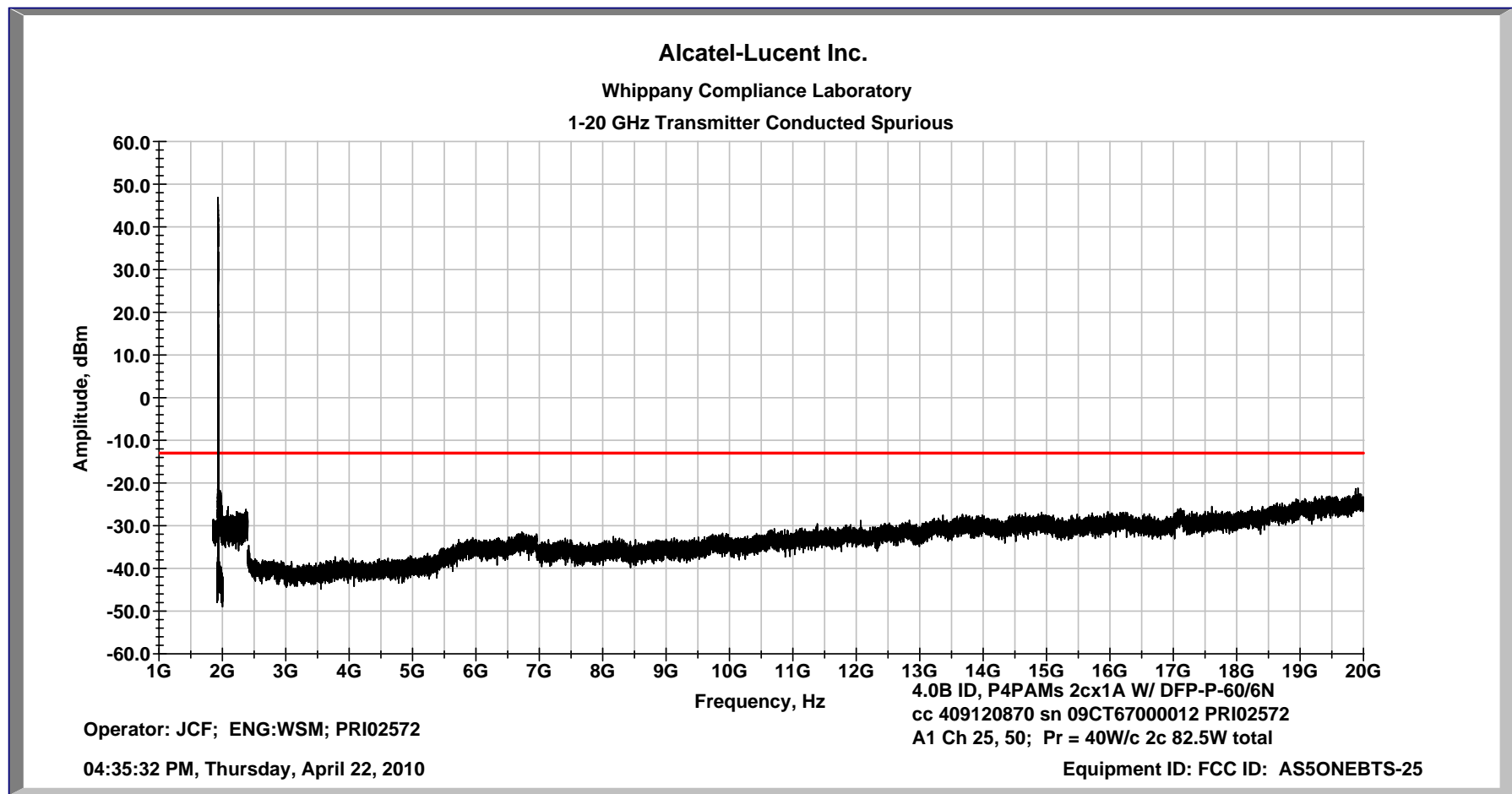
**Two Carrier Single Amplifier  
80 W/Amp 80W Total  
Conducted Spurious Emissions Data  
PCS Blocks A and G**

**Transmitter Conducted Spurious 10 MHz – 10 GHz PCS Ch A1-25, 50 Andrew P4PAM 2cx1A 40W/c 80W Total**

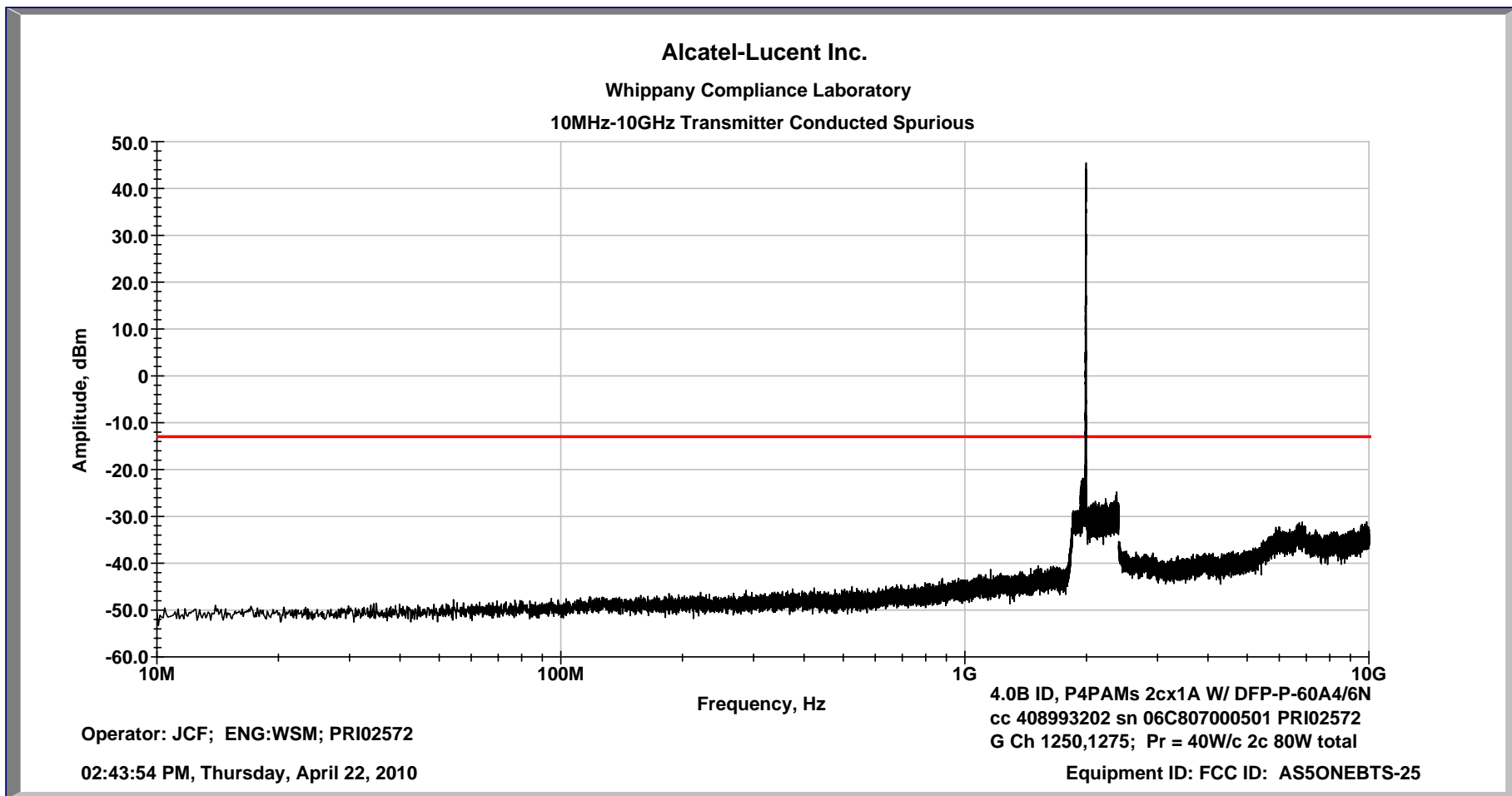




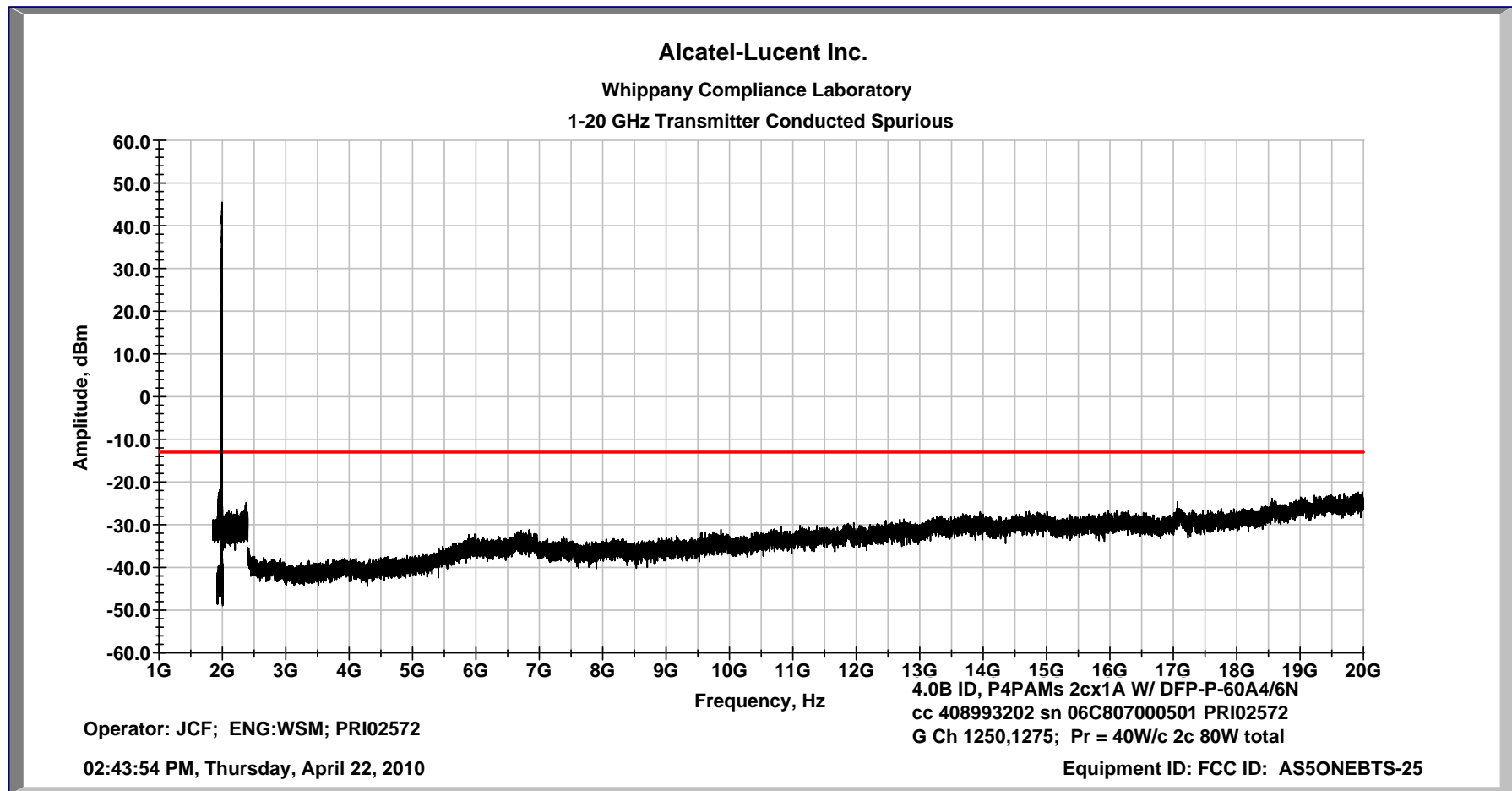
**Transmitter Conducted Spurious 1 GHz – 20 GHz PCS Ch A1-25, 50 Andrew P4PAM 2cx1A 40W/c 80W Total**



### Transmitter Conducted Spurious 10 MHz – 10 GHz PCS Ch GR-1250, 1275 Andrew P4PAM 2cx1A 40W/c 80W Total

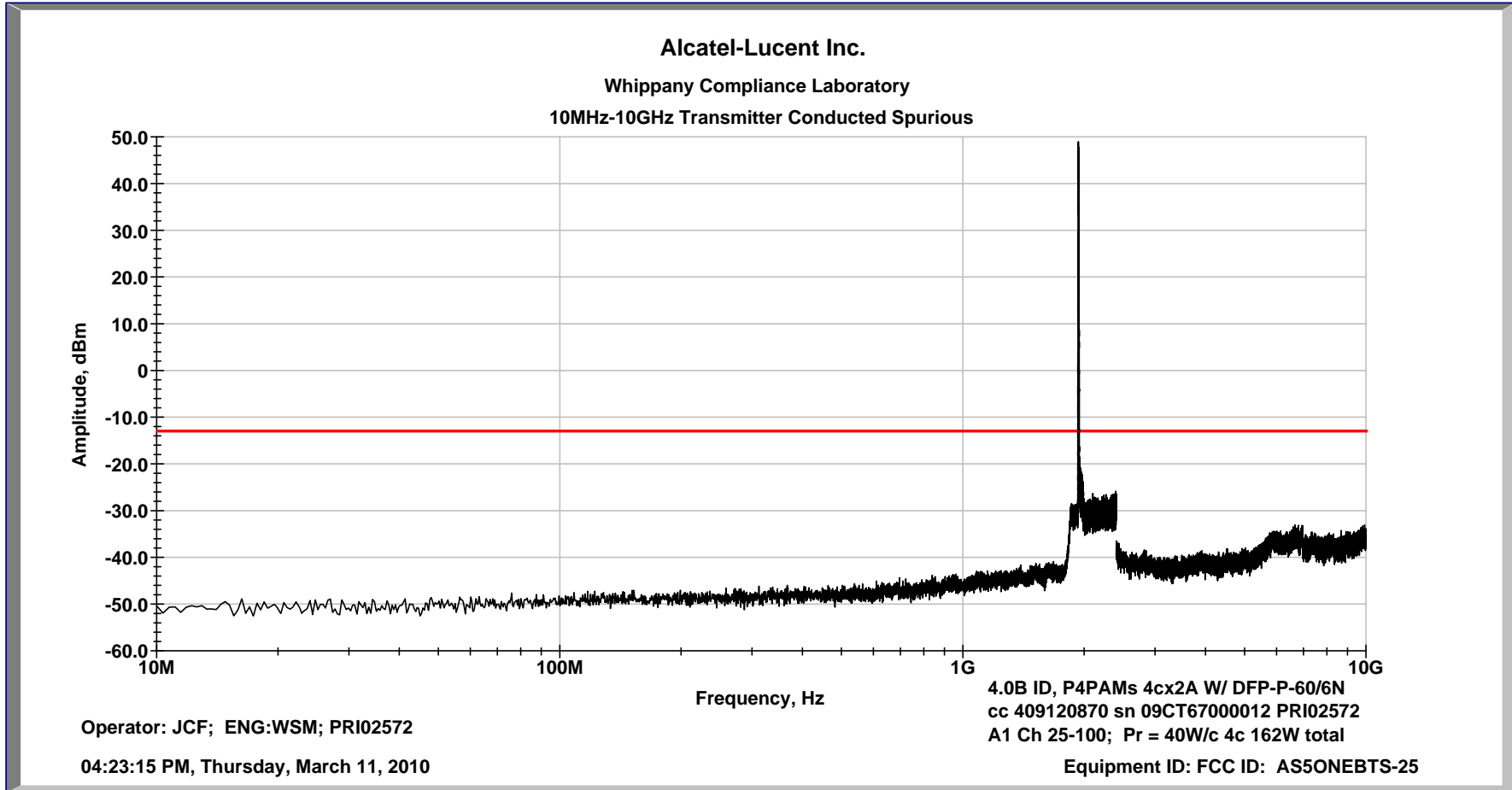


# Transmitter Conducted Spurious 1 GHz – 20 GHz PCS Ch GR-1250, 1275 Andrew P4PAM 2cx1A 40W/c 80W Total

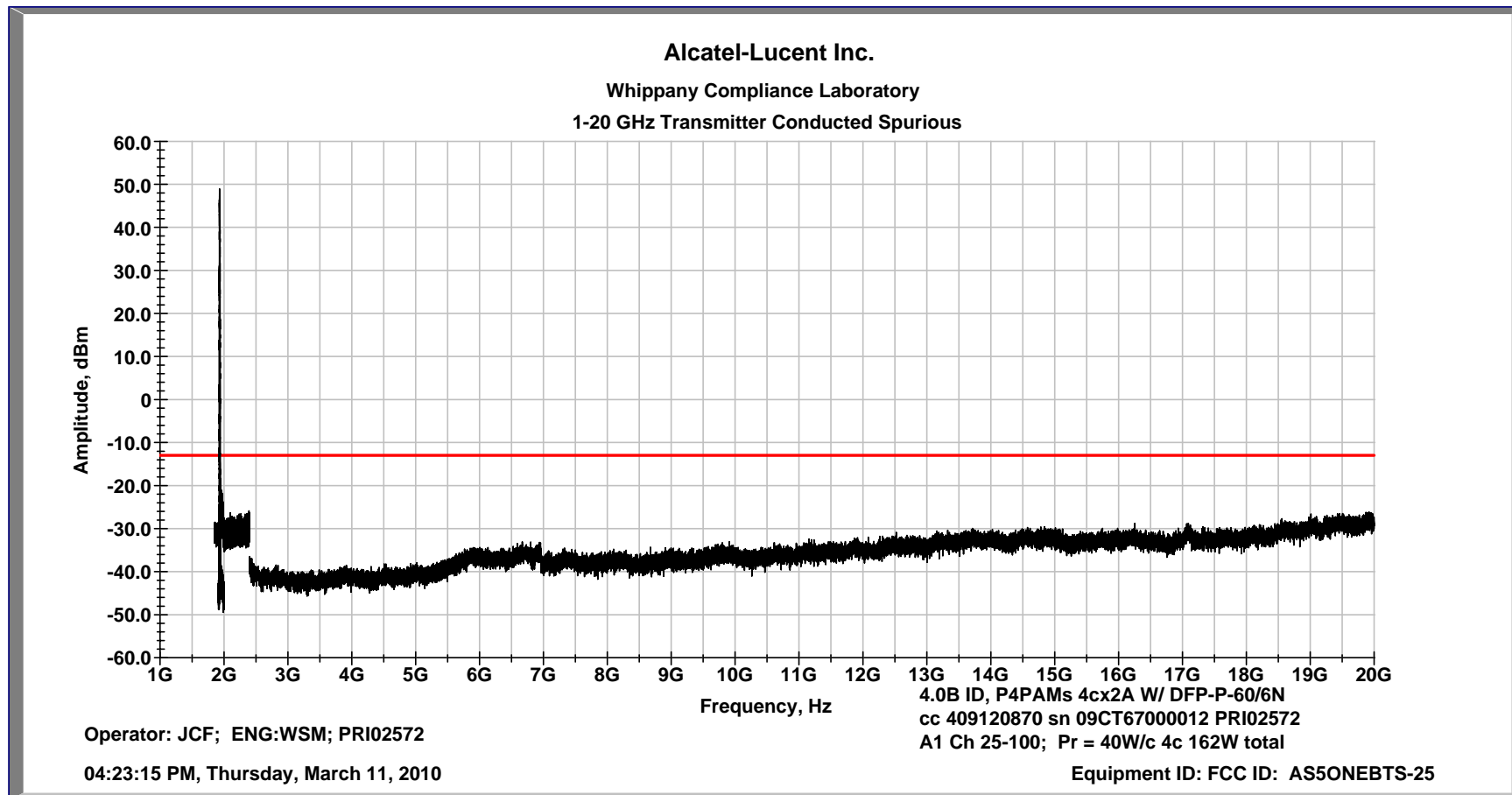


**Two Amplifier Four Carrier  
80 W/Amp 80W Total  
Conducted Spurious Emissions Data  
PCS Blocks A and G**

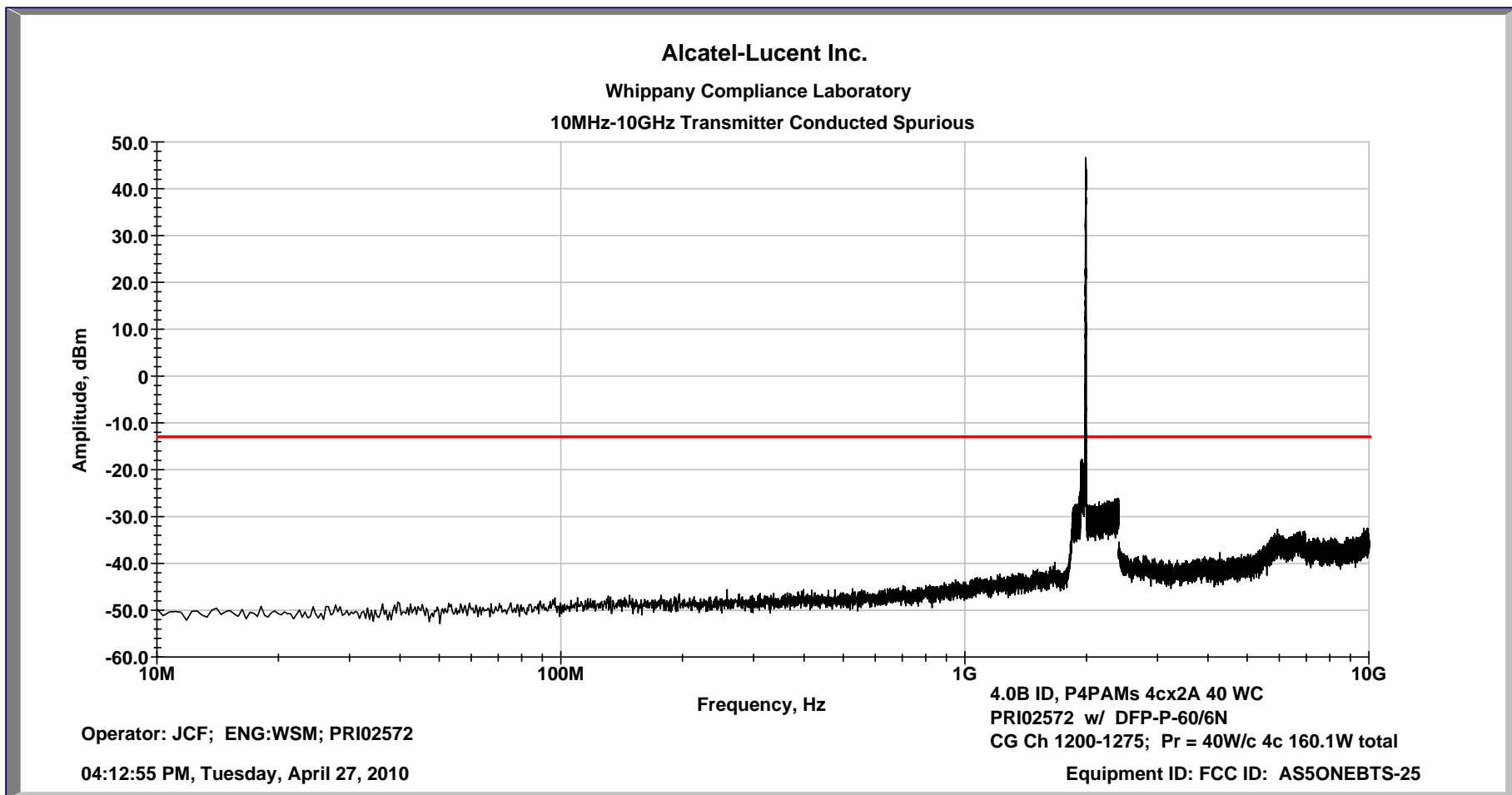
**Transmitter Conducted Spurious 10 MHz – 10 GHz PCS Ch A1-25-100 P4PAM 4cx2A 2Gv 20W/c 160W Total**



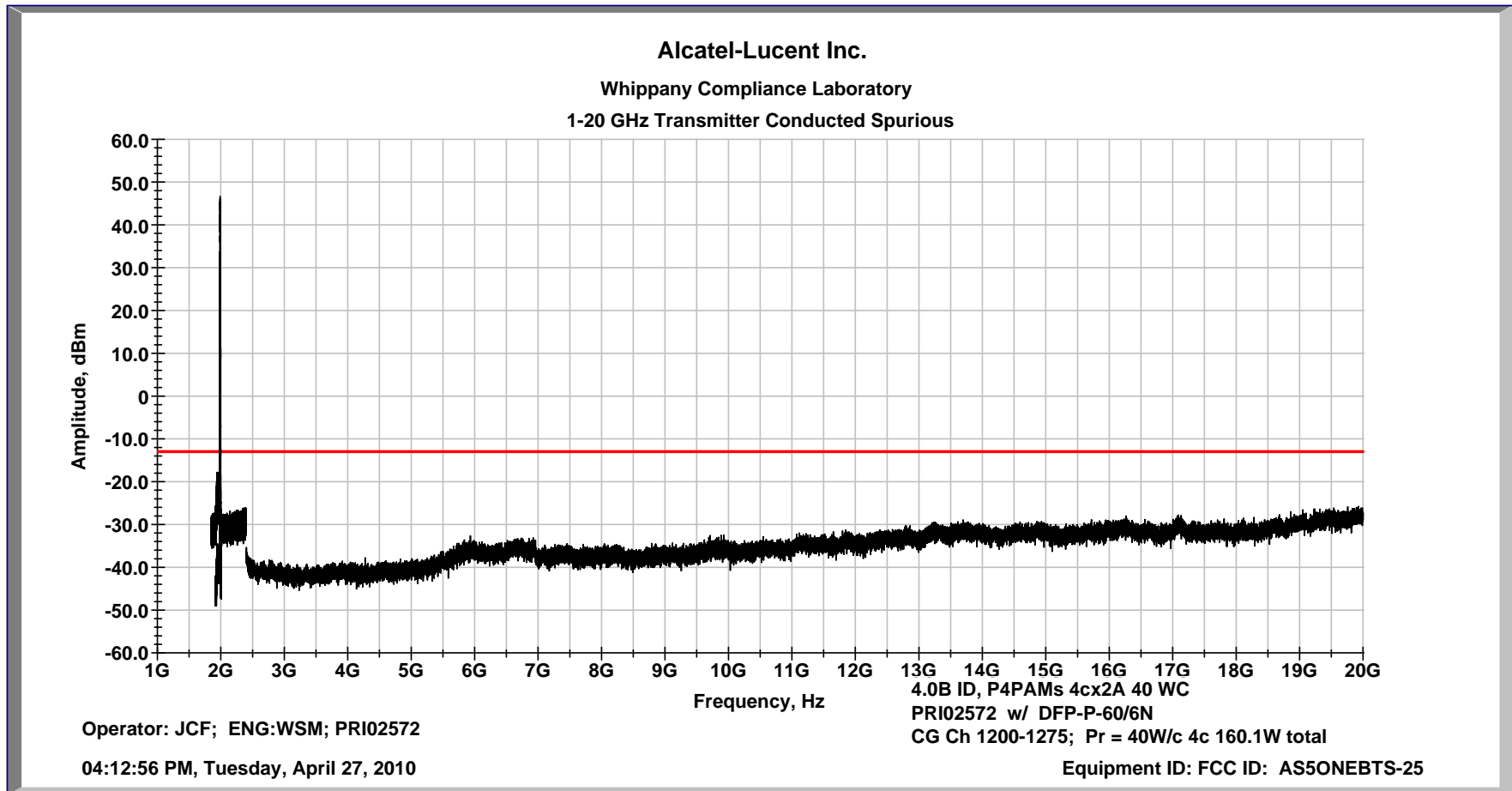
**Transmitter Conducted Spurious 1 GHz – 20 GHz PCS Ch A1-25-100 P4PAM 4cx2A 2Gv 20W/c 160W Total**



**Transmitter Conducted Spurious 10 MHz – 10 GHz PCS Ch CG-1200-1275 P4PAM 4cx2A 2Gv 20W/c 160W Total**



**Transmitter Conducted Spurious 1 GHz – 20 GHz PCS Ch CG-1200-1275 P4PAM 4cx2A 2Gv 20W/c 160W Total**







**EXHIBIT-16**

**FIELD STRENGTH OF SPURIOUS RADIATION**  
**SECTION 2.1053 and 24.238**

**MEASUREMENT: 5****SECTION 2.1053****FIELD STRENGTH OF SPURIOUS RADIATION**

Field strength measurements of radiated spurious emissions were made at 3 m semi anechoic room of Global Product Compliance Laboratory of Alcatel-Lucent Murray Hill. A complete description and full measurement data for the site is on file with the Commission (FCC File 515091).

The “**9228 Base Station Macro System** (Formally PCS FLEXENT 4.0 and 4.0B Modular Cells)” was tested with PCS High Efficiency EDPD P4PAM Transceiver System operating with a RF output of 80W composite power for single amplifier configuration and 160W composite power for two amplifier configuration at EAC. The operation of “**9228 Base Station Macro System**” was simulated digital control circuits, CDMA Transmit units (CTU) and PCS Multi-Carrier Radios (MCR-1900 FCC ID: AS5ONEBTS-09) using High Efficiency Enhanced Digital Predistortion (EDPD). The test cabinet was equipped with 11 Amplifiers covering edges of PCS bocks A, D, B, E, F, C and G. The tests were performed “**9228 Base Station Macro System**” which is a indoor cabinet. The radiated emissions tests were performed with amplifiers operating with 80W per amplifier and 160W per two amplifiers. All External Antenna Connector (EAC) of RF filters that were connected to amplifiers were terminated with 50 ohm loads. The spectrum from 10 MHz to the 22 GHz (more than 10th harmonic of the carrier) was searched for spurious radiation. Measurements were made according to ANSI C63.4 (2003).

All measurements were made the amplifiers operating in CDMA modulation mode.

All emissions more than 20 dB below the specification limit were considered not reportable (Section 2.1057(c)).

The calculated emission levels were found by:

Measured level (dB $\mu$ V) + Cable Loss (dB)+Antenna Factor (dB) = Field Strength (dB $\mu$ V/m)

Section 24.238 and 2.1053 contains the requirements for the levels of spurious radiation as a function of the level of the un-modulated carrier. The reference level for the un-modulated carriers calculated as the field produced by an ideal isotropic antenna excited by the transmitter output power according to the following relation taken from Reference Data for Radio Engineers, Page 27-7 6th edition, IT&T Corp

$$E = [(30 * P)^{1/2}] / R$$

$$20 \log (E * 106) - (43 + 10 \log P) = 82.2 \text{ dB } \mu\text{V/meter}$$

E = Field Intensity in Volts/meter

P = Transmitted Power in Watts

R = Distance from the ideal isotropic antenna in meters = 3 m

**RESULTS:**

For this particular test, the field strength of any spurious radiation is required to be less than 82.2 dB $\mu$ V/meter. Reportable measurements are equal to or greater than 62.2 dB $\mu$ V/meter. Over the spectrum investigated, 10 MHz to 10th of the carrier, no reportable spurious emissions were detected. This demonstrates that the “**9228 Base Station Macro System**” the subject of this application, complies with Sections 2.1053, 24.238 and 2.1057 of the Rules.

**EXHIBIT -18**

**FREQUENCY SPECTRUM TO BE INVESTIGATED  
SECTION 2.1057**

**SECTION 2.1057****FREQUENCY SPECTRUM TO BE INVESTIGATED**

**Frequency Spectrum to be investigated, Measurement Bandwidth and detector functions that were used meet or exceed the Specification contained in Section 2.1057, 24, and 3GPP2 C.S0010-C v2.0, 24 February 2006.**

The Frequency range of measurement is required to be from the lowest clock frequency to above the tenth harmonic of the transmit frequency.

**Response:**

The lowest RF clock frequency in the **PCS P4PAM EDPD Transceiver System** is the 10 MHz Precision Crystal reference oscillator. Conducted and Radiated spurious measurements were performed over the range of 10 MHz to 20 GHz which is above the tenth harmonic of the transmit frequency range. Measurements for conducted and radiated spurious emissions were continuous

The following pages include the data required for the Product Certification authorization of the **PCS P4PAM EDPD Transceiver System** / FCC ID: AS5ONEBTS-25, measured in accordance with the requirements set out in Section 2.1041 of the Rules.

## **Measurement Instrumentation and Antennas**

All instrumentations, antennas and test Chamber used for the purpose of tests contained in the report were in calibration and calibrations are traceable to NIST