

-
- 4 Remove the inside nuts and connector mounting bolts from their existing holes in the bracket.
-
- 5 Reverse and reinstall the brackets as shown in the figure below.

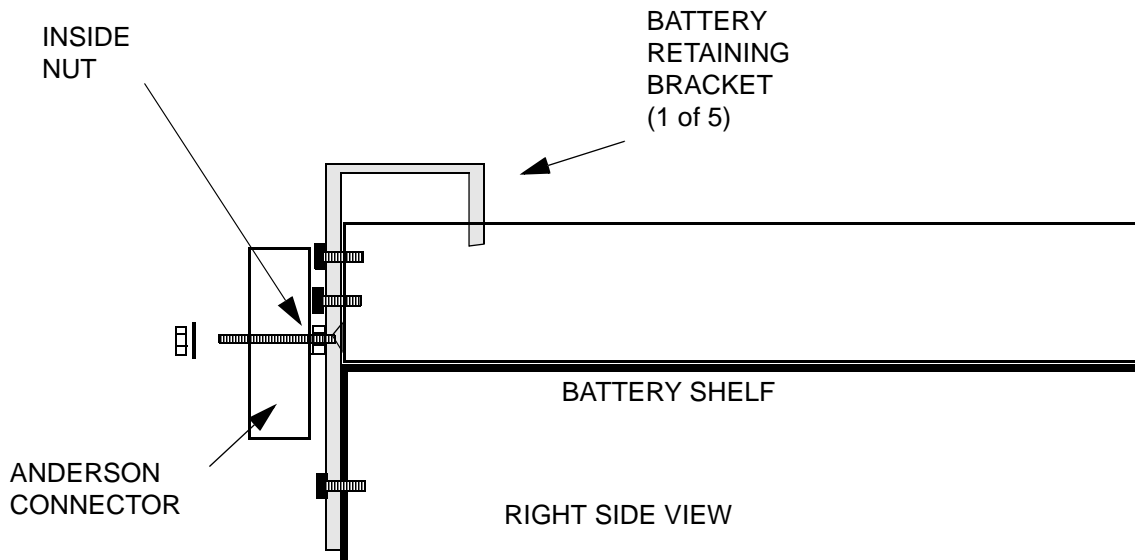

Important! When performing the next step, note that after the retaining bracket is reversed, the holes counter-sunk on the inside of the bracket will be the correct holes to use. Also note that the correct holes will always be the right-hand set viewed from the front of the correctly installed bracket.

-
- 6 Reinstall the connector mounting bolts in the C-11 holes. Refer to the figure on Page 5-70.
-
- 7 Replace the battery connectors on the brackets, and then reinstall the brackets on the shelf. Refer to the figure above.

END OF STEPS

**Place the battery negative
and positive bus bars**

Refer to the figure on Page 5-77, and perform the following steps to connect the negative and positive bus bars.

Important! Although all four parallel bus bars are identical, observe that the orientation of the positive and negative parallel bus bars is different on the left three batteries (1, 2 and 3) than on the right three batteries (4, 5 and 6). Also observe that the negative and positive pairs are positioned in a reverse orientation to each other. Refer to the figure on Page 5-77.

-
- 1** Apply antioxidant compound to the positive (+) terminal and negative (-) terminal of all batteries.

Important! When performing the next two steps, refer to the Step 5 figure on Page 5- 73. For batteries 1, 2, and 3, use "A" for positive bus bar installation and "B" for negative bus bar installation. For batteries 4, 5, and 6, use "C" for negative bus bar installation and "D" for positive bus bar installation.

-
- 2** Place bus bars on batteries 1, 2, and 3.
 - Place a bus bar (A) on the positive terminals with the bend facing toward the batteries.
 - Place a bus bar (B) on the negative terminals with the bend facing away from the batteries.

-
- 3** Place bus bars on batteries 4, 5, and 6.
 - Place a bus bar (C) on the negative terminals with the bend facing toward the batteries.
 - Place a bus bar (D) on the positive terminals with the bend facing away from the batteries.

-
- 4** Temporarily secure each bus bar in place with a washer and nut.

- 5 Repeat Steps 1 through 4 for all remaining battery shelves, if applicable. Refer to the figure below.

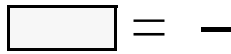
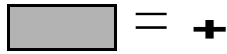

LEFT: BATTERIES 1, 2, 3
RIGHT SIDE VIEW

RIGHT: BATTERIES 4, 5, 6
RIGHT SIDE VIEW

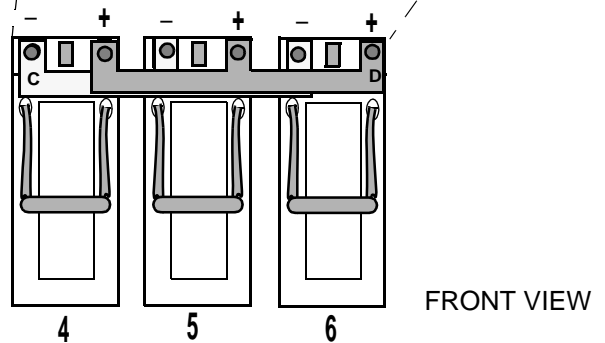
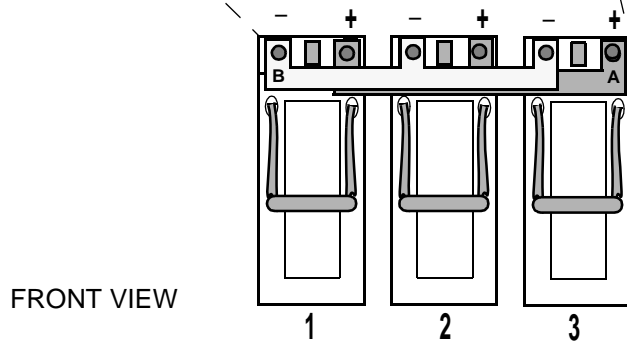
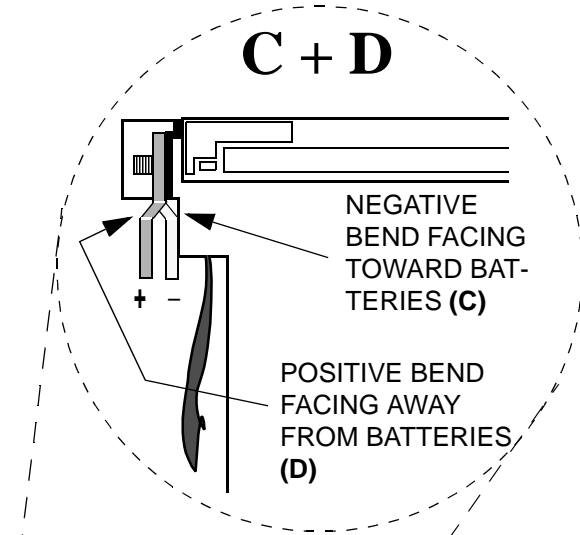
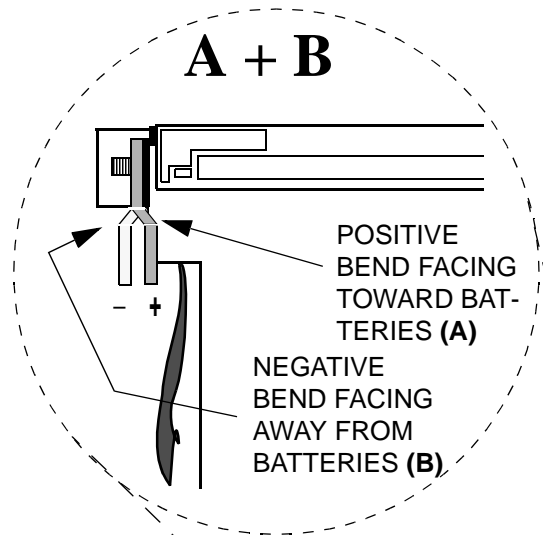
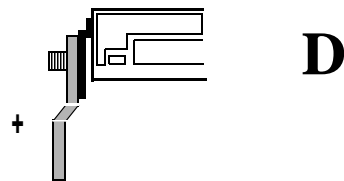
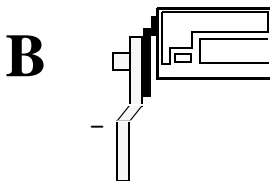
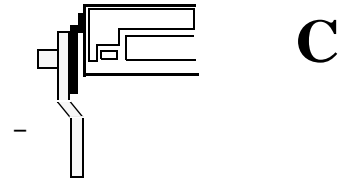
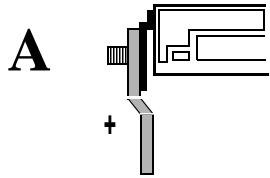

**Connect the positive
battery cables to the
batteries**

Important! When performing the following steps, for safety reasons, always connect the positive battery cables first and the negative battery cables last (when instructed to do so).

Perform the following steps to connect the positive battery cables to the batteries.

-
- 1** Locate the ten separately shipped battery cable assemblies.
-
- 2** Separate two of the battery cables. The positive cables from each of the two battery cables will be connected to the batteries in the next step.

Important! When performing the next step, note that the two positive battery cables being connected come from two separate battery connectors. Refer to the figure on Page 5-75.

-
- 3** Apply antioxidant compound to the two positive (+) terminals of batteries 5 and 6. Refer to the figure on Page 5-75.
-
- 4** Connect the two positive (+) battery cables (from separate connectors) to the positive (+) terminals of batteries 5 and 6, using the flat washers, lock washers and nuts.

- 5 Repeat Steps 2 through 4 for all remaining battery shelves, if applicable. Remember, for safety reasons, to connect the positive battery cables first and the negative battery cables last (when instructed to do so).

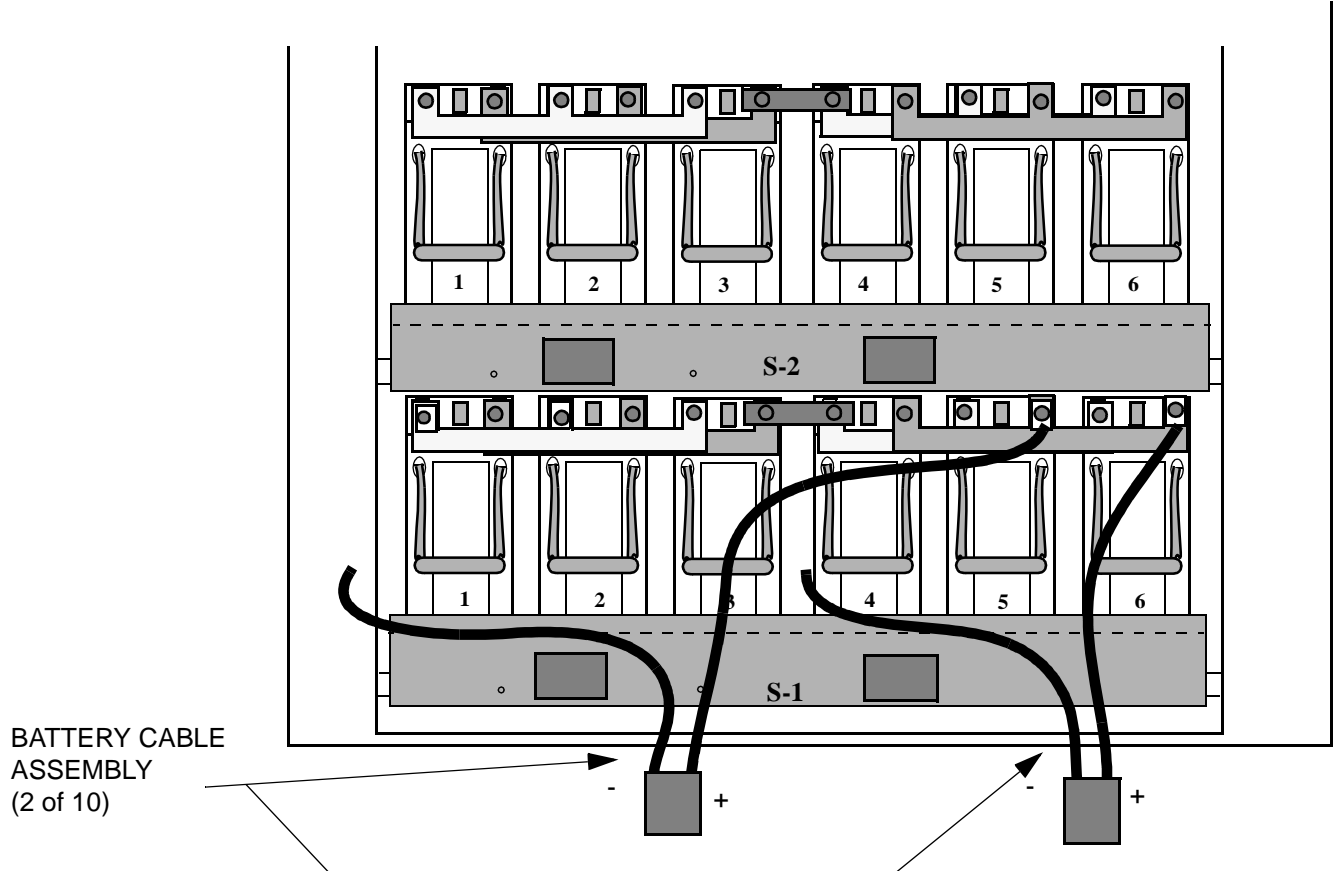

- 6 Do not torque the nuts on the positive battery connections at this time. The nuts on all positive battery connections will be torqued after mounting of the series bus bars in the next procedure.

END OF STEPS

**Attach the interconnecting
bus bars**

Perform the following steps to connect the interconnecting bus bars. Do the bottom shelf first.

- 1 Remove the series bus bar from the kit provided with the batteries.
- 2 Apply antioxidant compound to the interconnecting bus bar, the positive (+) terminal of battery 3, and the negative (-) terminal of battery 4. Refer to the figure below.
- 3 Place the interconnecting bus bar between the positive terminal of battery 3 and the negative terminal of battery 4.
- 4 Connect the interconnecting bus bar using the flat washers, lock washers and nuts. Refer to the figure below for a top view (for mounting order). Refer to the figure on Page 5-77 for a front view.

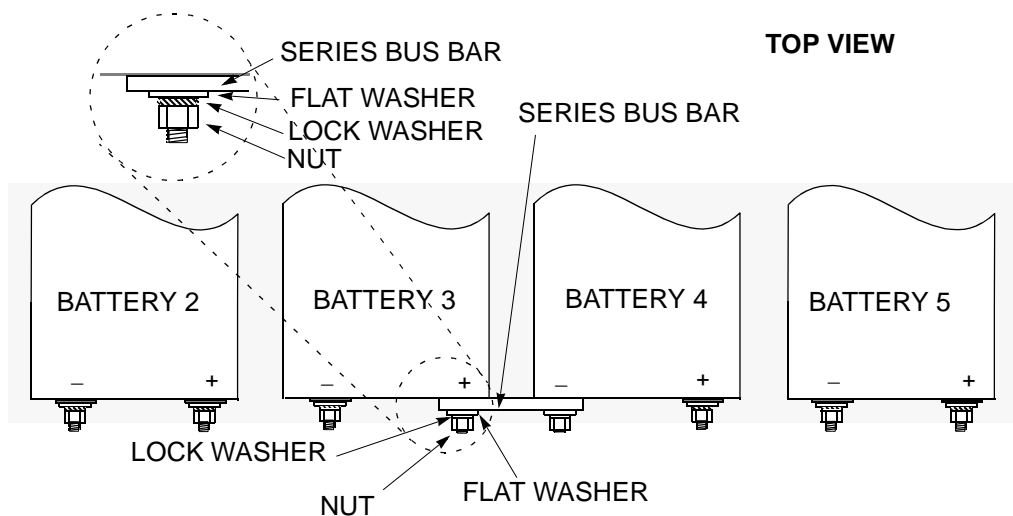

PARALLEL BUS BARS AND CABLES NOT SHOWN FOR CLARITY

- 5 Repeat steps 1 through 4 for the remaining battery shelves, if applicable. Refer to the figure below.

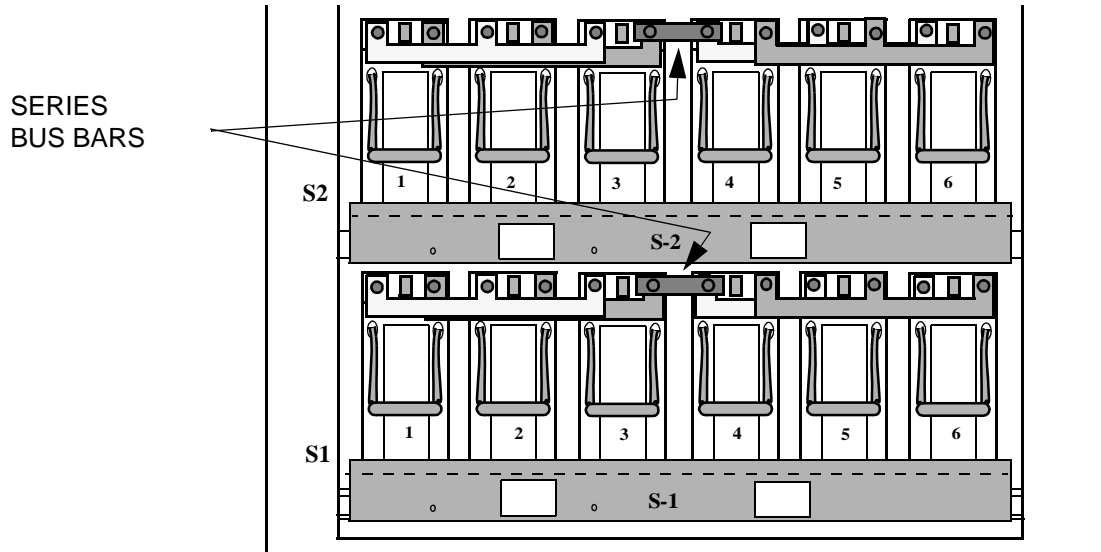

BATTERY CABLES NOT SHOWN FOR CLARITY

- 6 Torque the following connections using an insulated 10-mm socket and torque wrench set at 62 in.-lb. (7.0 Nm). Do not use the torque specifications provided in Chapter 1.
- All series bus bar connections (+ and -, all shelves)
 - All remaining positive battery connections, all shelves
 - Negative battery connections on batteries 5 and 6, all shelves

**Connect the negative
battery cables to the
batteries**

Perform the following steps to connect the negative battery cables to the batteries.

-
- 1** Separate two of the battery cables. The negative cables from each of the two battery cables will be connected to the batteries in the next step.

Important! When performing the next step, note that the two negative battery cables being connected come from two separate battery connectors. Refer to the figure on Page 5-80.

-
- 2** Apply antioxidant compound to the two negative (-) battery terminals of batteries 1 and 2. Refer to the figure on Page 5-79.

-
- 3** Connect the two negative (-) battery cables (from separate connectors) to the negative (-) terminal of batteries 1 and 2, using the flat washers, lock washers and nuts. Refer to the figure below.

- 4 Repeat Steps 2 and 3 for all remaining battery shelves, if applicable.

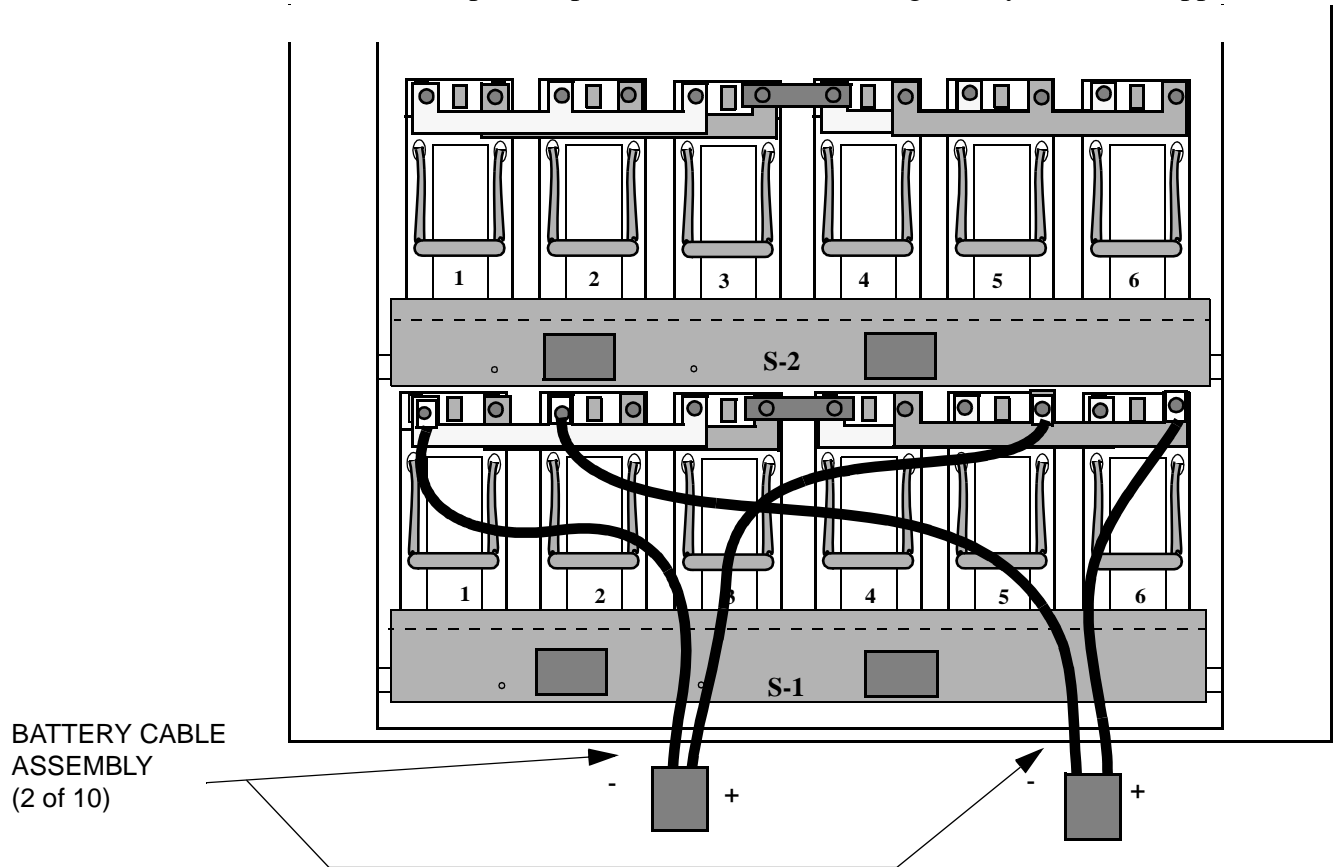

- 5 Torque all remaining negative connections using an insulated 7/16-inch socket and torque wrench set at 62 in.-lb. (7.0 Nm). Do not use the torque specifications provided in Chapter 1.

END OF STEPS

Install the insulating battery terminal covers

Perform the following steps to install the insulating battery terminal covers.

- 1 Place all insulating covers on the battery terminals, as shown in the figure below.

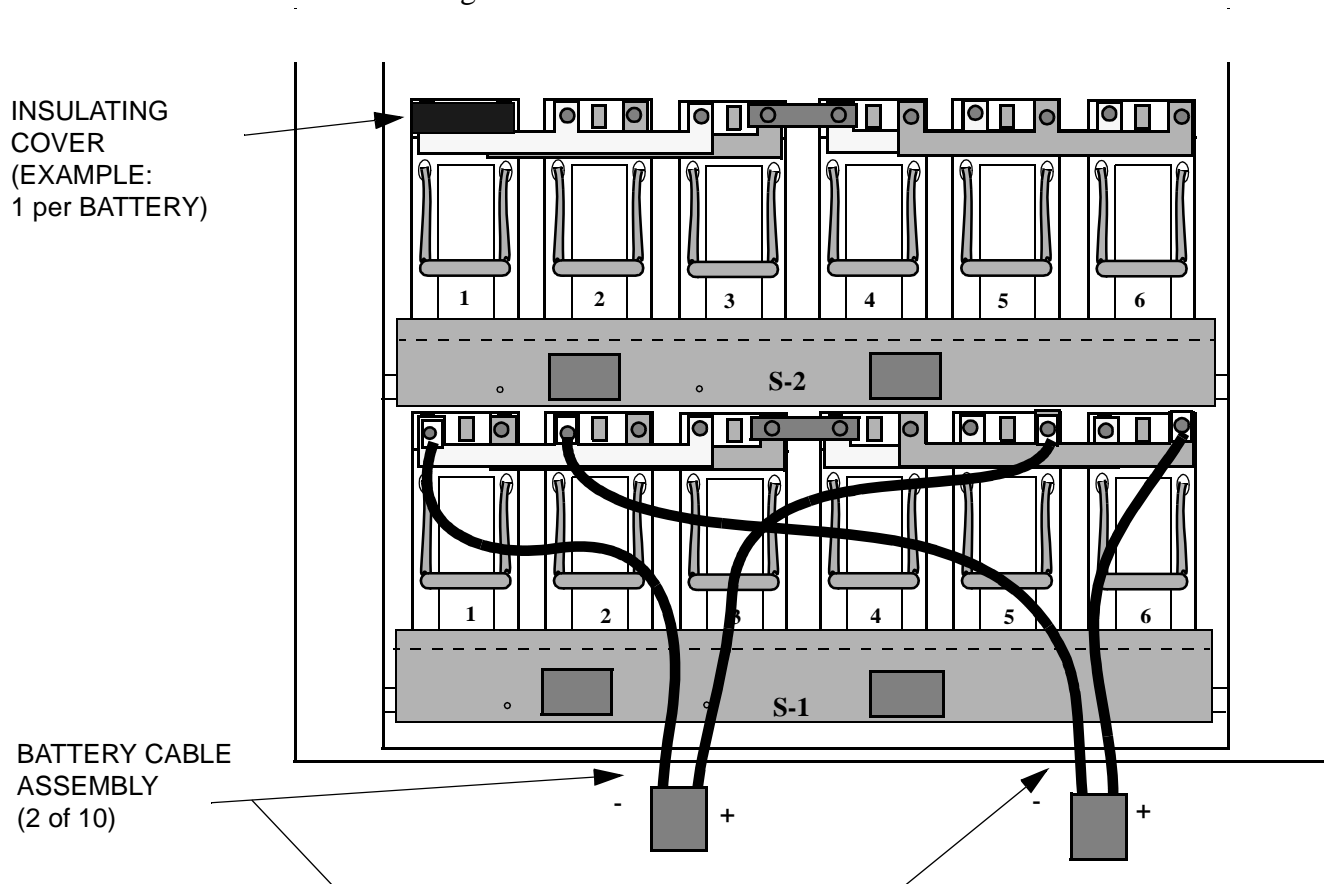

How to route the thermal probe cable(s) and mount the thermal probe(s) in the battery cabinets

IMPORTANT NOTE

THERMAL PROBE INSTALLATION INSTRUCTIONS VARY FOR FIRST AND SECOND BATTERY CABINETS. A THERMAL PROBE CABLE AND THERMAL PROBE ARE SHIPPED WITH THE FIRST BATTERY CABINET. IF ONLY ONE BATTERY CABINET IS BEING INSTALLED, THE THERMAL PROBE MUST BE PLACED IN THE FIRST BATTERY CABINET. A SECOND THERMAL PROBE CABLE IS SHIPPED WITH THE SECOND BATTERY CABINET. THIS CABLE IS CONNECTED TO THE THERMAL PROBE CABLE IN THE FIRST BATTERY CABINET, AND ROUTED TO THE SECOND BATTERY CABINET. THE THERMAL PROBE IS THEN MOVED TO THE SECOND BATTERY CABINET AND CONNECTED TO THE SECOND CABLE. FOLLOW THE INSTRUCTIONS CAREFULLY

**Route the thermal probe
cable from the 4.0B primary
cabinet and mount the
thermal probe in the
battery cabinet**

Important! If currently installing a second battery cabinet with a 4.0B primary cabinet, skip to Step 2 for routing and positioning of thermal probe cable and thermal probe.

Perform the following steps to route the thermal probe cable and mount the thermal probe in the battery cabinet. A plastic mounting bracket with double sided tape and a wire tie is supplied with each thermal probe.

- 1 For installations with a 4.0B primary cabinet, route the thermal probe cable and mount the thermal probe on the battery retaining bracket as listed in the following instructions.
 - If the cabinet is fully populated with 10 strings (20 batteries):
 - Route the thermal probe cable to the top shelf battery retaining bracket and mount the thermal probe on the center of the bracket. Refer to the figure on Page 5-82, item 1.
 - If the cabinet is not fully populated with batteries:
 - Route the thermal probe cable to the top populated shelf battery retaining bracket and mount the thermal probe on the center of the bracket. Refer to the figure on Page 5-82, item 2.
- 2 If installing a second battery cabinet, refer to the figure and instructions on Page 5 - 82.
- 3 Remove the thermal probe from the retaining bracket in the first battery cabinet and unplug it from the thermal probe cable. Refer to the figure below, item 3.
- 4 Relocate the removed thermal probe on the shelf 5 battery retaining bracket (or highest populated shelf location) in the second battery cabinet. Refer to the figure below, item 4 or 5.
- 5 Locate the thermal probe cable supplied with the second battery cabinet. Refer to the figure below, item 6. Plug this cable into the cable from the

primary cabinet (item 7), route it to the second battery cabinet, and connect it to the thermal probe (item 8).

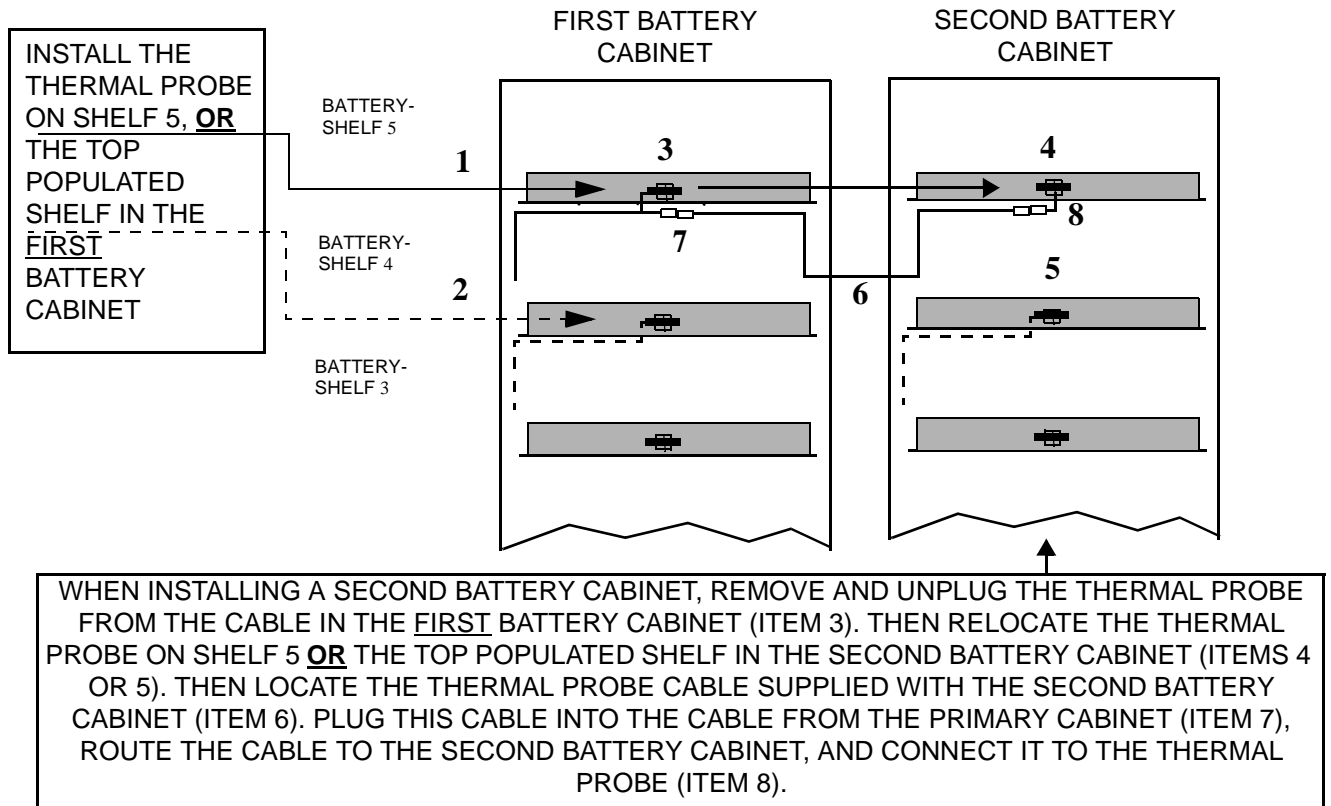

- 6 To complete the installation of the first or second WNG24-BC battery cabinet, skip to "How to make final DC connections after installation of a battery cabinet", on page 5-84.

How to make final DC connections after installation of a battery cabinet

Overview This section provides the procedures for the final DC connections in the Modular Cell 4.0B primary cabinet and the first and/or second WNG24-BC battery cabinet, as applicable.

<u>Connect the first battery cabinet +24-VDC cables at the HPDA in the Modular Cell 4.0B primary cabinet</u>	5 - 85
<u>Connect the DC return cables from the battery cabinet to the return bus in the primary cabinet</u>	5 - 87
<u>Connect the battery cables in the first and/or second WNG24-BC battery cabinets</u>	5 - 88



DANGER **Electrical Shock Hazard**

Failure to follow the order of the installation procedure (as written) can result in an energized DC circuit, which creates an electrical shock hazard. Follow these rules:

- 1. Perform installation steps exactly as written and in the order provided.*
- 2. Do not connect battery connectors on the battery retaining brackets until instructed to do so.*
- 3. Observe and follow all safety precautions.*
- 4. When completing electrical connections, always use tools that are properly insulated.*



DANGER
Electrical Shock Hazard

When completing electrical connections, always use tools that are properly insulated.

Connect the first battery cabinet +24-VDC cables at the HPDA in the Modular Cell 4.0B primary cabinet

Important! When performing the following steps subsequent to the installation of the second battery cabinet, note that the four 24-VDC return cables in the Modular Cell 4.0B primary cabinet were previously disconnected for safety reasons.

Perform the following steps to connect the four +24-VDC cables (from the first battery cabinet) in the primary cabinet.

- 1 Loosen the screw and open the HPDA door. Refer to the figure below.

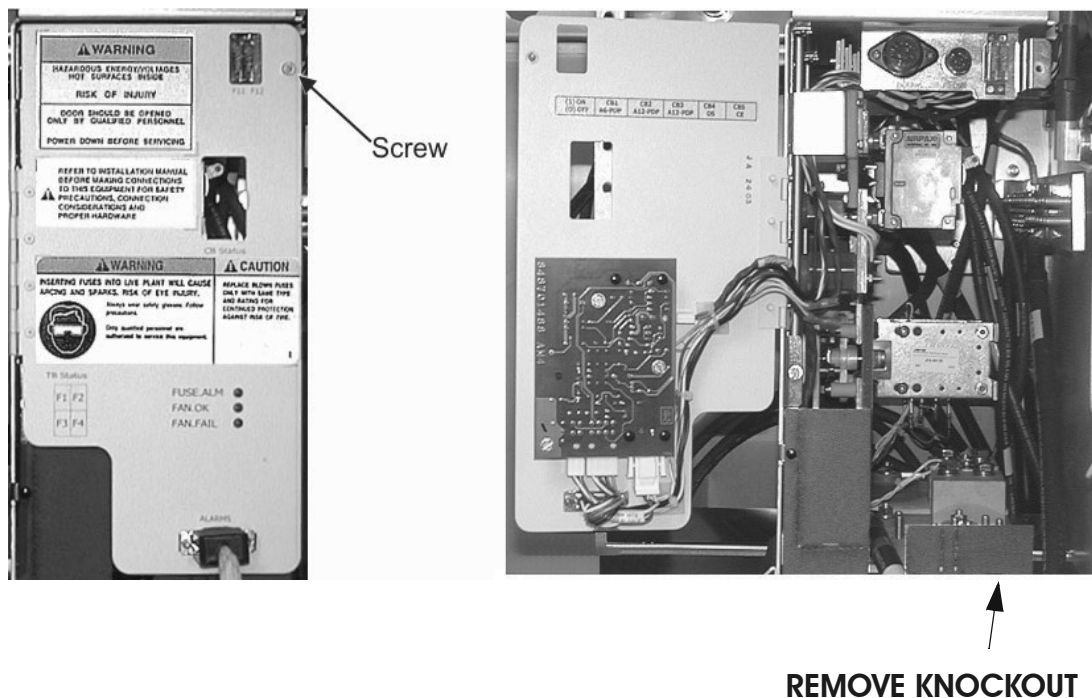

Important! If installing a second battery cabinet only, skip to Connect the DC return cables from the battery cabinet to the return bus in the primary cabinet on Page 5 - 87 to continue the installation.

- 2 Remove the knockout shown in the figure above.
- 3 Remove the tape or shrink tubing from the end of one of the four red +24-VDC cables.
- 4 Connect this +24-VDC cable (from the first battery cabinet) in the Modular Cell 4.0B primary cabinet. Refer to the figure below.

-
- 5 Repeat Steps 2 and 3 for the three remaining +24-VDC cables.

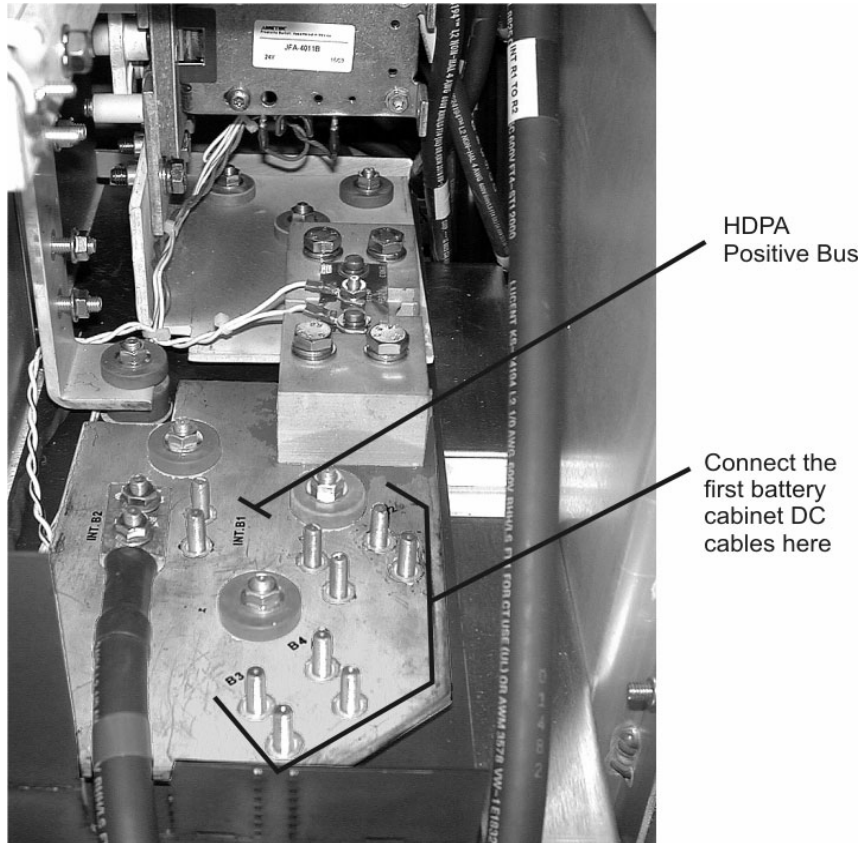

Connect the DC return cables from the battery cabinet to the return bus in the primary cabinet

Perform the following steps to connect the four 24-VDC return cables from the battery cabinet to the return bus in the primary cabinet

-
- 1 Remove the tape or shrink tubing from the end of one of the four black 24-VDC return cables.
-
- 2 Connect (or reconnect) this 24-VDC return cable (from the first battery cabinet) in the Modular Cell 4.0B primary cabinet.

-
- 3 Repeat Steps 5 and 6 for the four 24-VDC return cables. Refer to the figure below.

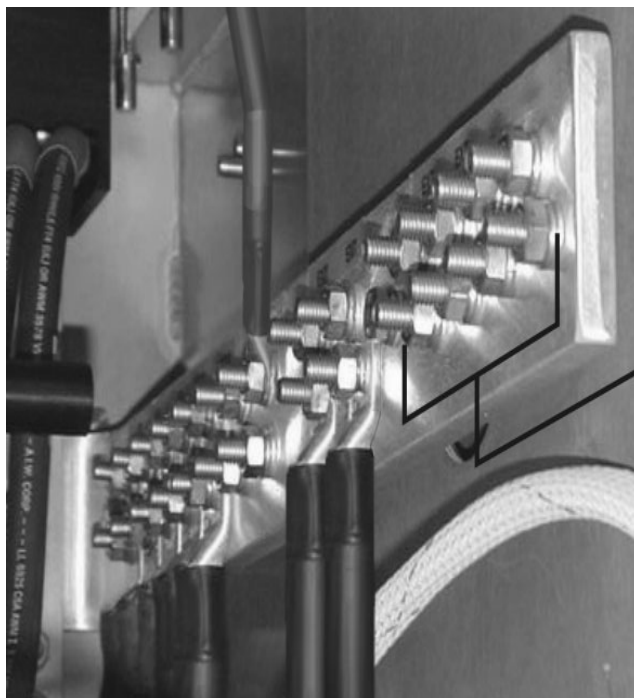

Connect or reconnect four 24-VDC
return wires from battery cabinet here

-
- 4 Torque all DC cable connections. Refer to the electrical torque specifications provided in Chapter 1.

END OF STEPS

**Connect the battery cables
in the first and/or second
WNG24-BC battery
cabinets**

Important! Refer to the figures on Page 5 - 91 for the battery wiring diagram and battery cabling plan for C-11 batteries. Refer to the figures on Page 5 - 92 for the battery wiring diagram and battery cabling plan for L1, L2, and 12IR125 batteries. Use these figures when measuring voltages, determining polarities and rewiring battery cables, if required.

Perform the following steps to connect the battery cables on the battery retaining brackets in the first and/or second battery cabinet, as applicable. If installing the second battery cabinet only, skip to Step 4.

1 At the first battery cabinet, measure the voltage at the connector of each of the newly installed battery cables, to determine if the polarity is correct. Use the procedure provided on Page 5 - 9, Step 11. Refer to the figure on Page 5-90, item 1.

2 Repeat the test in the previous step, for the battery connectors to be plugged into the ones already tested.

3 Rewire any battery cables found to be incorrectly wired.

Important! If installing the first battery cabinet only, skip the next two steps.

4 Repeat Steps 1 and 2 for the second battery cabinet.

5 Rewire any battery cables found to be incorrectly wired.

Important! Before performing the next step, be sure that AC power is connected to the Modular Cell 4.0B cabinet, AC power is turned on at the main panel, and all AC circuit breakers are ON at the primary cabinet.

-
- 6 At the first battery cabinet, make all of the battery cable connections on the front of the battery retaining brackets. Refer to the figure below, item 2.

Important! If installing the first battery cabinet only, skip the next step.

-
- 7 At the second battery cabinet, make all of the battery cable connections on the front of the battery retaining brackets. Refer to the figure below, item 2.

-
- 8 If applicable, place all unused battery cable assemblies in a plastic bag on an unpopulated battery shelf.

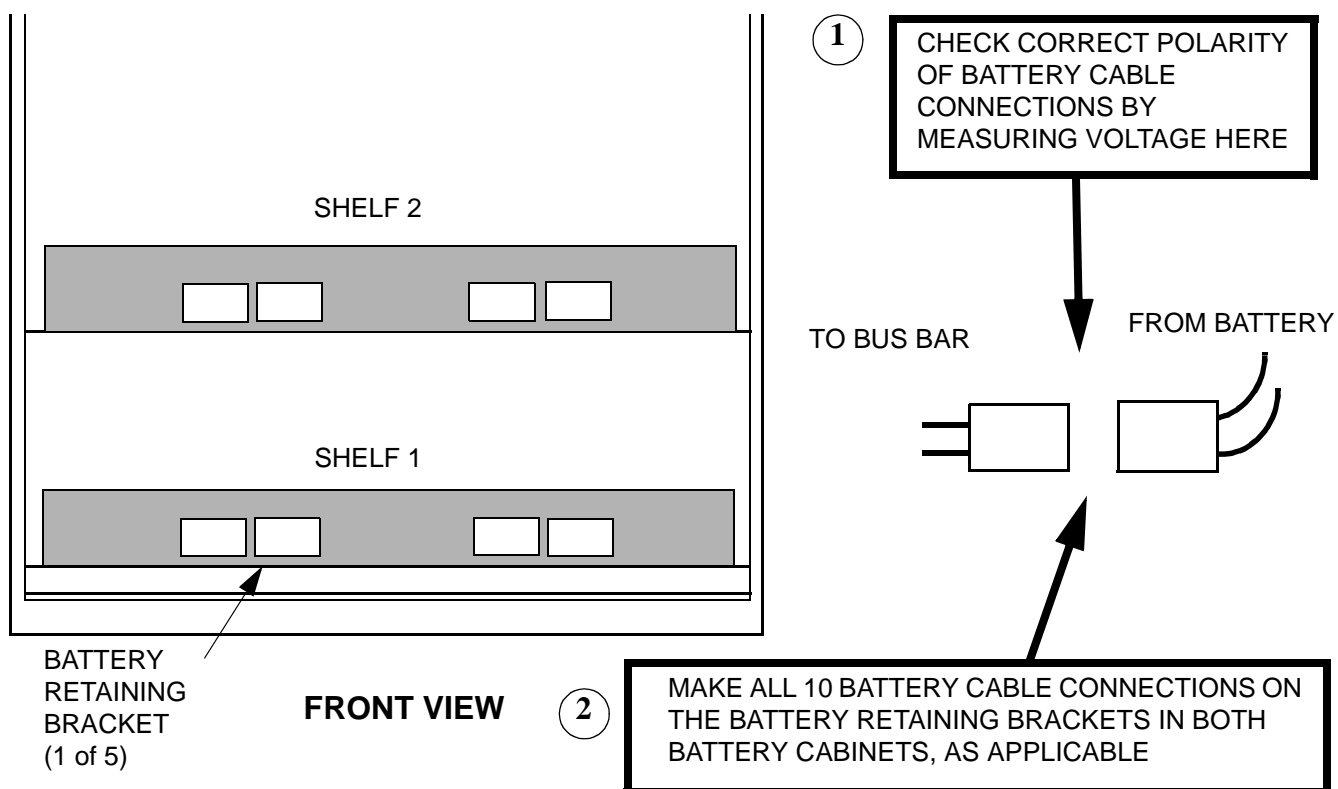

The figure below shows the battery wiring diagram for C-11 batteries. The left three batteries are connected in parallel with each other, as are the right three batteries. The two sets of three batteries are connected in series via the series bus bar. The strings on the shelves are then connected in parallel via the connectors on the battery compartment front panel. Refer to the figure below. Note that type 2 battery shelves are shown. The fixed connector is turned 180 degrees on type 1 shelves.

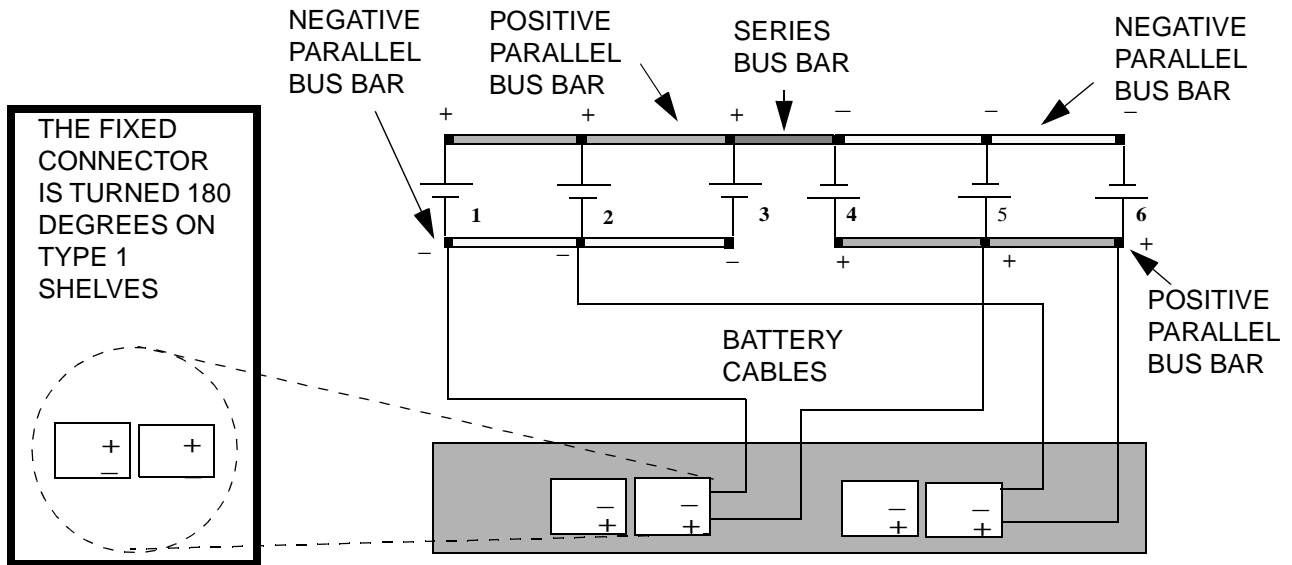

The figure below shows the battery cabling plan.

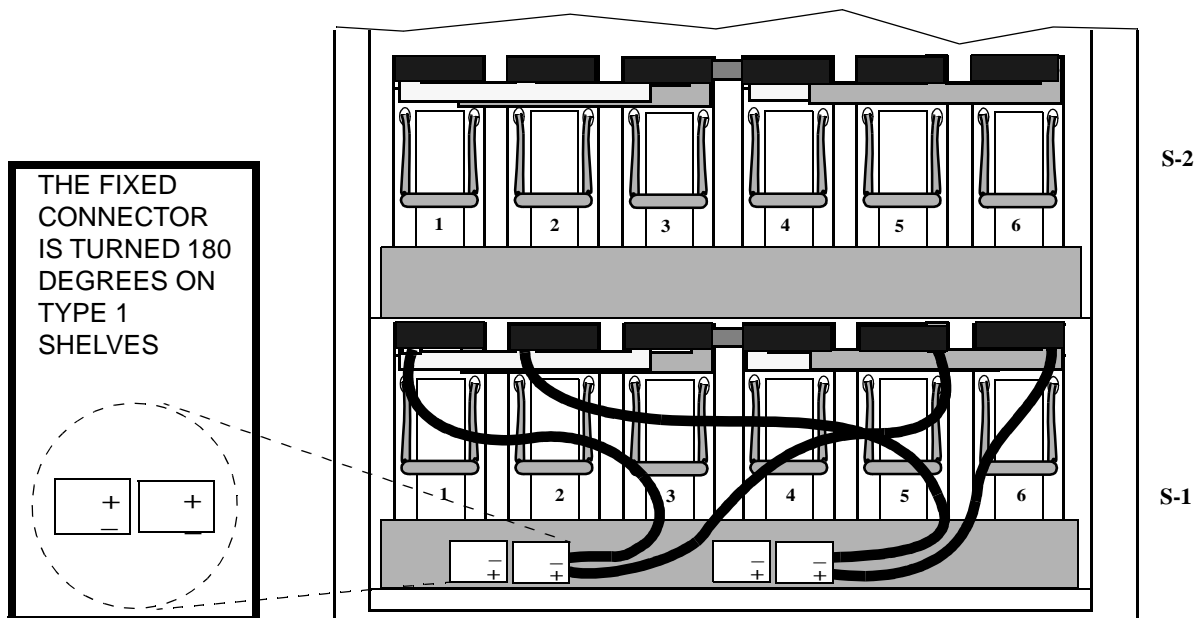

The figure below shows the battery wiring diagram for L1, L2, and 12IR125 batteries. The battery pairs are connected in series via the interconnecting bus bar; the positive (+) terminal is connected to the negative (-) terminal on the adjacent battery. Both strings on a shelf are then connected in parallel via the connectors on the battery compartment front panel. **Note that type 2 battery shelves are shown.** The fixed connector is turned 180 degrees on type 1 shelves.

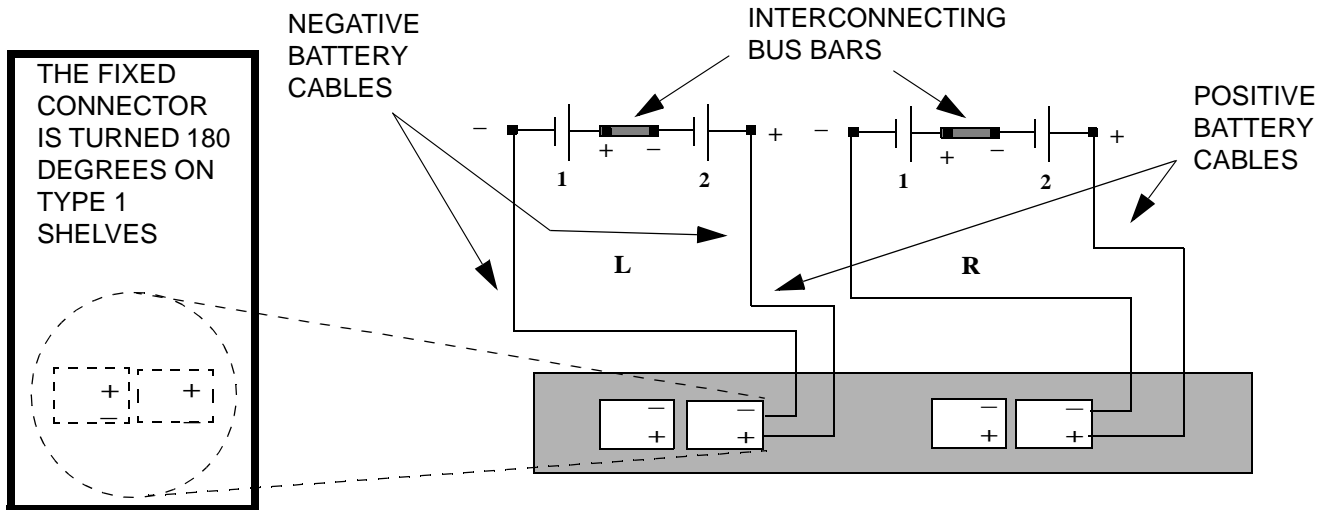

The figure below shows the battery cabling plan.

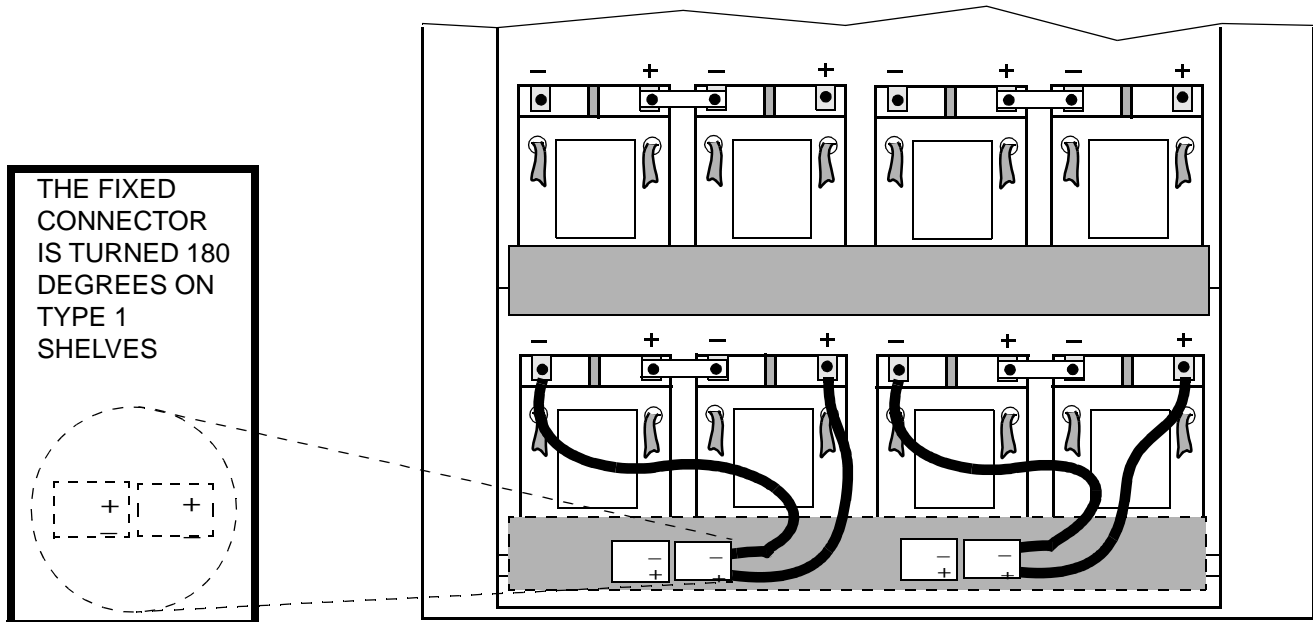



6 RF cable connections between existing Modular Cell cabinets and a 4.0B dual band cabinet

Overview

Purpose A Modular Cell 4.0B dual band cabinet may be added to certain existing Modular Cell line-ups. This chapter describes the procedures for the installation of inter-frame RF cables from a Modular Cell 4.0B dual band cabinet to the existing Modular Cell cabinets.

Contents This chapter contains the following sections.

<u>Procedures for the use of this chapter</u>	6 - 2
<u>Routing and connection of RF inter-frame cables to a 4.0B Modular Cell dual band cabinet</u>	6 - 8

Procedures for the use of this chapter

Objectives This module provides instructions for the proper use of Chapter 6. Perform the following to determine the correct procedures to use in order to efficiently route and connect the applicable inter-frame cables.

<u>Read cabinet definitions</u>	6 - 3
<u>Identify your line-up configuration</u>	6 - 4
<u>Determine the prerequisite changes needed in the existing cabinet(s) in your line-up configuration</u>	6 - 5

Read cabinet definitions

Primary Cabinet: *The first radio cabinet. In this chapter the first radio (primary) cabinet is assumed to have already been installed.*

Dual Band Cabinet (DB): *An additional cabinet that has a different band than the primary cabinet.*

G-1 Cabinet:

- *The first existing additional cabinet. It may be a 1.0, 2.0, 3.0 or 4.0 growth cabinet depending upon the line-up configuration.*
- *A 4.0 B dual band cabinet being installed with a 4.0B primary cabinet.*

G-2 Cabinet: *The second existing additional cabinet, It may be a 4.0 growth cabinet only.*

G-3 Cabinet: *The third additional cabinet being installed. It may be a 4.0B dual band cabinet only.*

Identify your line-up configuration

Important! Not all of the line-ups listed below are existing configurations

Use the following table to identify your line-up configuration. Then proceed to the next page to determine the prerequisites in existing cabinets using the established line-up configuration number.

IF ADDING A:	AND AN EXISTING G-2 CABINET MODEL:	AND AN EXISTING G-1 CABINET MODEL:	WITH AN EXISTING PRIMARY CABINET MODEL:	THEN USE LINE-UP CONFIGURATION:
4.0B Dual Band G-1 Cabinet	NONE	N/A	4.0B	1
4.0B Dual Band G-2 Cabinet	NONE	4.0	4.0	2
4.0B Dual Band G-2 Cabinet	NONE	4.0	1.0/2.0	3
4.0B Dual Band G-2 Cabinet	NONE	4.0	3.0	4
4.0B Dual Band G-3 Cabinet	4.0	1.0/2.0	1.0/2.0	5
		3.0		
4.0B Dual Band G-3 Cabinet	4.0	3.0	3.0	6

Determine the prerequisite changes needed in the existing cabinet(s) in your line-up configuration

Before connecting cables between the 4.0B dual band cabinet being installed and the existing cabinet(s), changes may be required in the existing cabinet(s). Use the following tables to determine the prerequisite changes required for the existing cabinet(s), depending upon your line-up configuration. These changes must be performed prior to the connection of cabling between the 4.0B dual band cabinet being added and the existing cabinet(s). Instructions for the installation of the prerequisite parts are included in the individual parts shipment.

Important! After making the required changes, proceed to Routing and connection of RF inter-frame cables to a 4.0B Modular Cell dual band cabinet, on Page 6 - 8 for the procedures to use to route and connect the cables.

Important! Not all of the line-ups listed in the table that follows are existing configurations

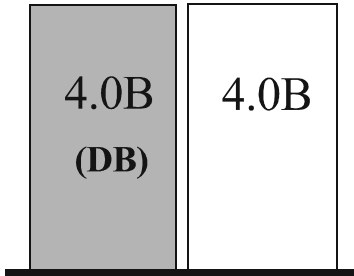
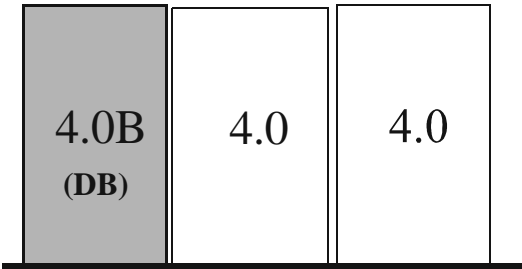
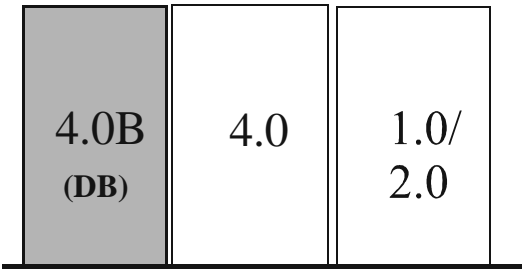
LINE-UP CONFIGURATION AND NUMBER	PREREQUISITES	
	G-1 or G-2 CABINET	PRIMARY CABINET
<p>1</p> <p style="text-align: center;">G-1 PRI</p> 	N/A	NONE
<p>2</p> <p style="text-align: center;">G-2 G-1 PRI</p> 	Installation of two 15 MHz splitters in the 4.0 G-1 cabinet.	Replacement of the GPS splitter in the primary cabinet with a 1:5 splitter
<p>3</p> <p style="text-align: center;">G-2 G-1 PRI</p> 	NONE	Replacement of the GPS splitter in the primary cabinet with a 1:5 splitter

LINE-UP CONFIGURATION AND NUMBER	PREREQUISITES					
	G-1 or G-2 CABINET	PRIMARY CABINET				
<p>4</p> <p style="text-align: center;">G-2 G-1 PRI</p> <table border="1" style="margin-left: auto; margin-right: auto;"> <tr> <td style="background-color: #cccccc; text-align: center;">4.0B (DB)</td> <td style="text-align: center;">4.0</td> <td style="text-align: center;">3.0</td> </tr> </table>	4.0B (DB)	4.0	3.0	NONE	Replacement of the GPS splitter in the primary cabinet with a 1:5 splitter	
4.0B (DB)	4.0	3.0				
<p>5</p> <p style="text-align: center;">G-3 G-2 G-1 PRI</p> <table border="1" style="margin-left: auto; margin-right: auto;"> <tr> <td style="background-color: #cccccc; text-align: center;">4.0B (DB)</td> <td style="text-align: center;">4.0</td> <td style="text-align: center;">1.0/2.0, 3.0</td> <td style="text-align: center;">1.0/ 2.0</td> </tr> </table>	4.0B (DB)	4.0	1.0/2.0, 3.0	1.0/ 2.0	Installation of a 15 MHz splitter in the 4.0 G-2 cabinet.	NONE
4.0B (DB)	4.0	1.0/2.0, 3.0	1.0/ 2.0			
<p>6</p> <p style="text-align: center;">G-3 G-2 G-1 PRI</p> <table border="1" style="margin-left: auto; margin-right: auto;"> <tr> <td style="background-color: #cccccc; text-align: center;">4.0B (DB)</td> <td style="text-align: center;">4.0</td> <td style="text-align: center;">3.0</td> <td style="text-align: center;">3.0</td> </tr> </table>	4.0B (DB)	4.0	3.0	3.0	Installation of a 15 MHz splitter in the 4.0 G-2 cabinet.	NONE
4.0B (DB)	4.0	3.0	3.0			

Routing and connection of RF inter-frame cables to a 4.0B Modular Cell dual band cabinet

Overview This module covers the following procedures required to route and connect the inter-frame cables from the Modular Cell 4.0B dual band cabinet being installed to the existing Modular Cell 4.0B, 4.0, 3.0, 2.0, or 1.0 primary, or G-2 4.0 growth cabinet, as applicable. A line-up table is provided at the end (for reference only).

Route and connect the 15-MHz cable(s)	6 - 9
Route and connect the GPS cable	6 - 18
Line-up table	6 - 26

Before you begin Before proceeding with these instructions, refer to [Determine the prerequisite changes needed in the existing cabinet\(s\) in your line-up configuration](#) on Page 6 - 5 to assure that all prerequisites for the connection of inter-frame cables have been met.

Route and connect the 15-MHz cable(s)

Perform the following steps to route and connect the 15-MHz cable(s) to and in the primary cabinet, or first growth cabinet, if applicable. Refer to the table starting on Page. 6 - 12 for cable routing and connection.

- 1 Determine the number of the cabinet line-up configuration which will be created by the addition of the 4.0B dual band cabinet being installed.
- 2 Using the line-up configuration number, locate the line-up in the table starting on Page. 6 - 12.
- 3 The 15-MHz cable (or cables) are shipped already attached in the Modular Cell 4.0B dual band cabinet being installed. Locate the 15-MHz cable(s) coiled inside the bottom of the Modular Cell 4.0B dual band cabinet being installed. Refer to the applicable line-up in the table starting on Page. 6 - 12, and uncoil only as much of the cable as required to reach:
 - For line-up 1: the left OMU-xx and right OMU-xx ports in the 4.0 primary cabinet (two cables). Refer to the figure on Page 6-12
 - For line-up 2: the two splitters in the 4.0 G-1 cabinet (two cables). Refer to the figure on Page 6-13
 - For line-up 3: the Smart Switch on the inside left wall of the 1.0, or 2.0 primary cabinet (one cable). Refer to the figure on Page 6-16
 - For line-up 4: the Smart Switch on the shelf under the amplifiers in the 3.0 primary cabinet (one cable). Refer to the figure on Page 6-14
 - For line-ups 5 and 6: the single splitter in the 4.0 G-2 cabinet (one cable). Refer to the figure on Page 6-17.

4 In the Modular Cell 4.0B dual band cabinet being installed, route the 15-MHz cable(s) up the inside right side, and through the RF cable gasket between the cabinets. Route the cable(s) to the applicable cabinet as follows:

- For line-up 1, route the two cables into the primary cabinet
- For line-up 2, route the two cables into the G-1 cabinet
- For line-ups 3 and 4, route the single cable through the G-1 cabinet and into the primary cabinet
- For line-ups 5 and 6, route the single cable into the G-2 cabinet

Important! For line-up 4 (three cabinet line-up with 3.0 primary cabinet), continue to the next step. For all other line-ups skip to Step 10 on Page 6 - 11.

5 Line-up 4, Figure on page 6-14: In the 3.0 primary cabinet, if the air baffle is not mounted on the door, remove the air baffle from above the radio shelves. Refer to the figure below.

3.0 MODULAR CELL PRIMARY CABINET

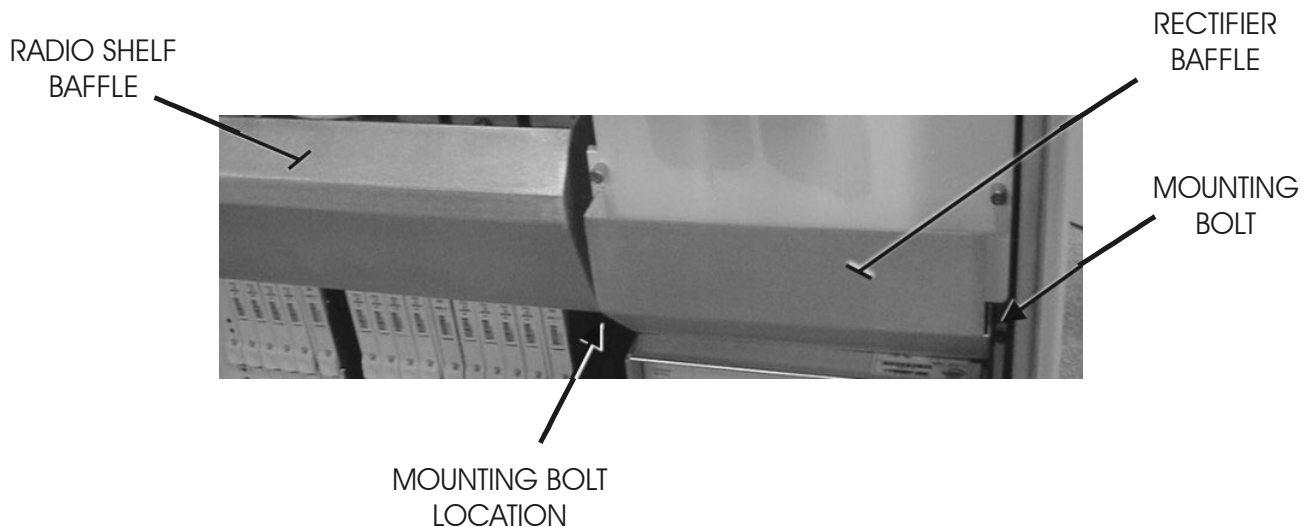

Important! When performing the next step note that the cables at the Smart Switch connectors J3, J4, and J9 can become disconnected if care is not taken when sliding out the shelf.

-
- 6 Remove the bolts from the front of the shelf, on which the Smart Switch is located, and carefully pull out the shelf. Refer to the figure below.

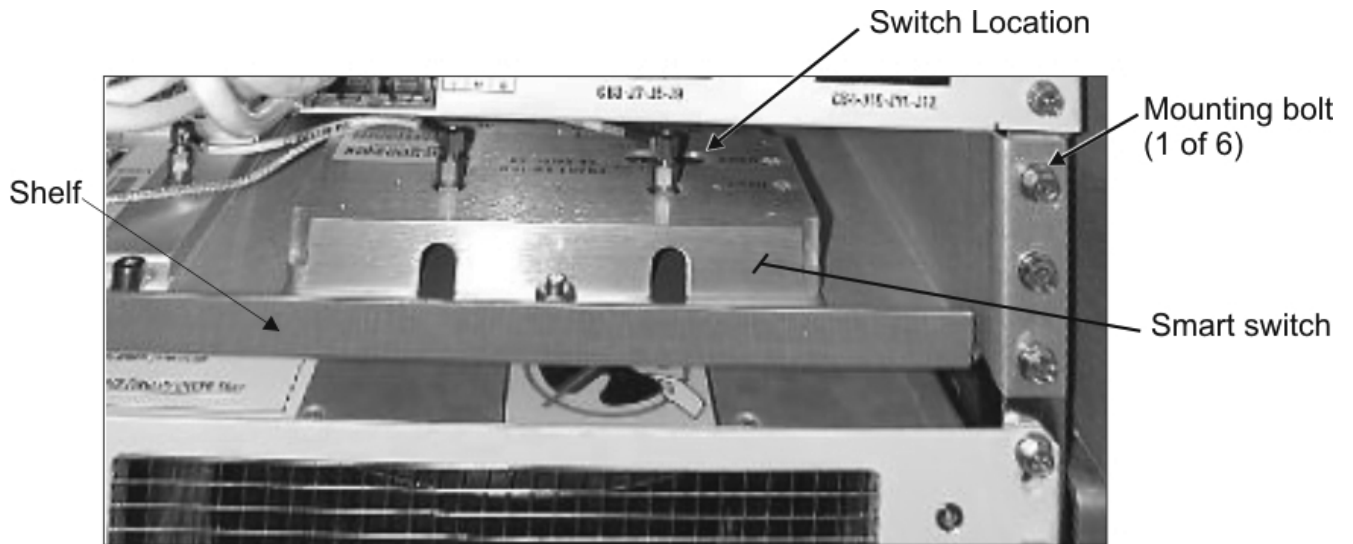

-
- 7 Route the cable onto the shelf and connect the 15-MHz cable(s), and set the Smart Switch dip switches as shown for line-up 4 in the table starting on Page. 6 - 12. Refer to the figure on Page 6-14.

-
- 8 Slide the shelf back into the cabinet and replace the bolts. If the air baffle was mounted on the door., replace the air baffle above the radio shelves.

Important! If the primary cabinet is a 3.0, skip the next step.

-
- 9 For line-ups 1 through 3, and 5 and 6, connect the 15-MHz cable(s), as shown for the applicable line-up in the table starting on Page. 6 - 12.

-
- 10 Coil the unused portion of the 15-MHz cable in the Modular Cell 4.0B dual band cabinet being installed.

-
- 11 Using wire ties, secure the cables in all cabinets in such a way that they do not interfere with removal / replacement of components, and front door closure.

15 MHZ INTER-FRAME CABLES: LINE-UP 1

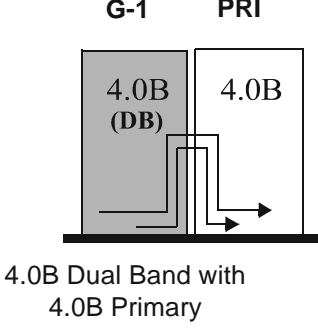
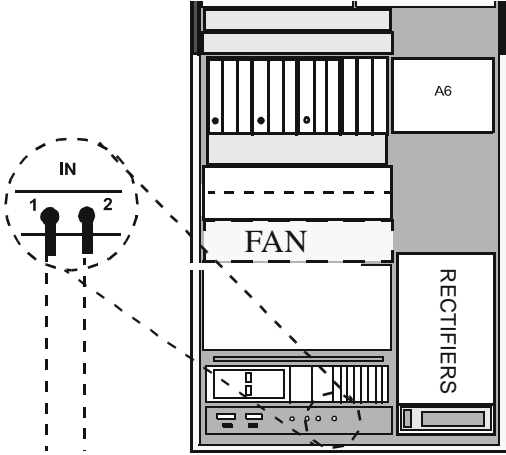
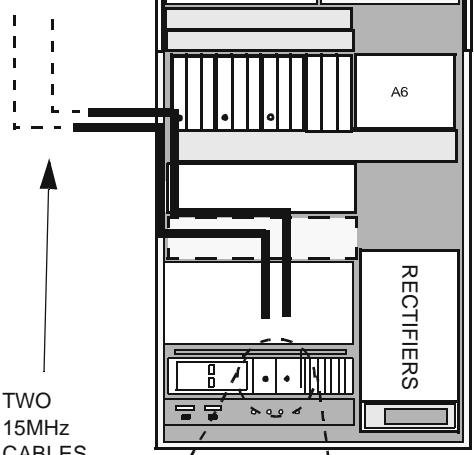
LINE-UP	PRIMARY CABINET CONNECTION	PROCEED TO:
<p>1</p> <p>G-1 PRI</p>  <p>4.0B Dual Band with 4.0B Primary</p>	<p>MODULAR CELL 4.0B DUAL BAND CABINET</p>   <p>TWO 15MHz CABLES</p> <p>MODULAR CELL 4.0B PRIMARY CABINET</p>	<p>"Route and connect the GPS cable". Line-up 1</p>

15 MHZ INTER-FRAME CABLES: LINE-UP 2

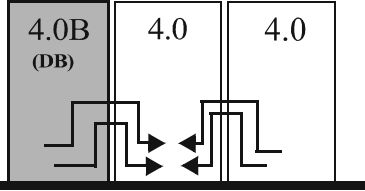
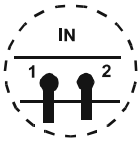
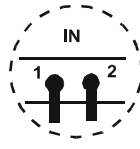
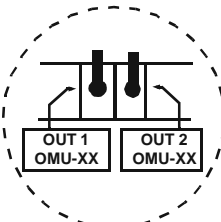
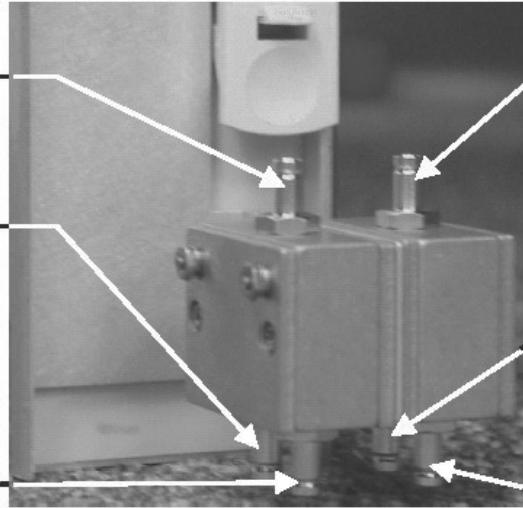

LINE-UP	PRIMARY CABINET CONNECTION	PROCEED TO:
<p>2</p> <p>G-2 G-1 PRI</p>  <p>4.0B Dual Band with 4.0 G-1 and 4.0 Primary</p>	<p>The existing cable connections from the G-1 cabinet in the 4.0 primary cabinet remain the same as they were. A kit is supplied to install two 15MHz splitters in the G-1 cabinet. Installation instructions are supplied with the kit. 15MHz connections from all three cabinets are made to these splitters as shown in the illustration below.</p>	<p>"Route and connect the GPS cable", Line-up 2</p>
<p>4.0B DUAL BAND G-2 CABINET</p> 	<p>4.0 G-1 CABINET</p> 	<p>4.0 PRIMARY CABINET</p> 
 <div style="display: flex; justify-content: space-between;"> <div style="width: 30%;"> <p>From Primary Cabinet OM Out 1</p> <p>Cable to/from 15 MHz IN-1 on Digital Shelf In 4.0 G-1 Cabinet</p> <p>Cable from 15 MHz IN-1 on Digital Shelf In 4.0B Dual Band Cabinet (G-2)</p> </div> <div style="width: 30%;"> <p>From Primary Cabinet OM Out 2</p> <p>Cable to/from 15 MHz IN-2 on Digital Shelf In 4.0 G-1 Cabinet</p> <p>Cable from 15 MHz IN-2 on Digital Shelf In 4.0B Dual Band Cabinet (G-2)</p> </div> </div>		

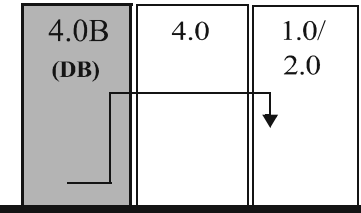
15 MHZ INTER-FRAME CABLE: LINE-UP 3

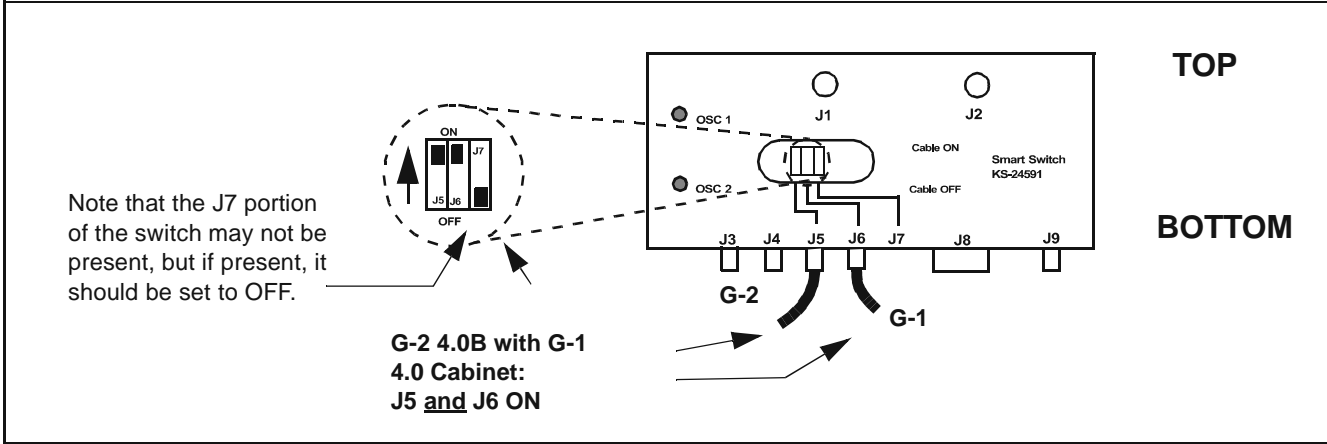
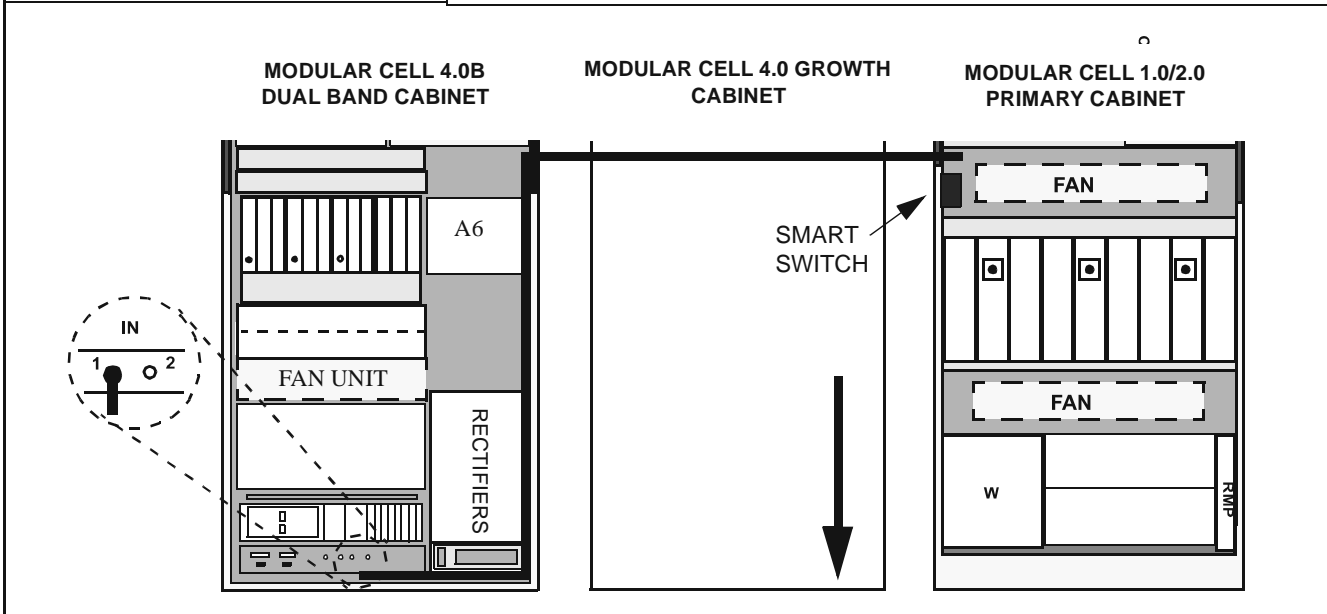
LINE-UP	PRIMARY CABINET CONNECTION	PROCEED TO:						
<p>3</p> <table border="1" style="margin-left: auto; margin-right: auto;"> <tr> <td style="text-align: center;">G-2</td> <td style="text-align: center;">G-1</td> <td style="text-align: center;">PRI</td> </tr> <tr> <td style="text-align: center;">4.0B (DB)</td> <td style="text-align: center;">4.0</td> <td style="text-align: center;">1.0/ 2.0</td> </tr> </table>  <p style="text-align: center;">4.0B Dual Band with 4.0 G-1 and 1.0/2.0 Primary</p>	G-2	G-1	PRI	4.0B (DB)	4.0	1.0/ 2.0	<p>Connect the 15MHz cable to the J5 port on the "Smart Switch" in the 1.0/2.0 primary cabinet as shown in the bottom illustration below.</p>	<p>"Route and connect the GPS cable". Line-up 3</p>
G-2	G-1	PRI						
4.0B (DB)	4.0	1.0/ 2.0						



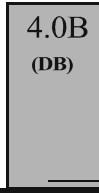

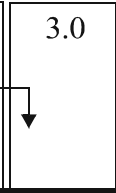
15 MHZ INTER-FRAME CABLES: LINE-UP 4

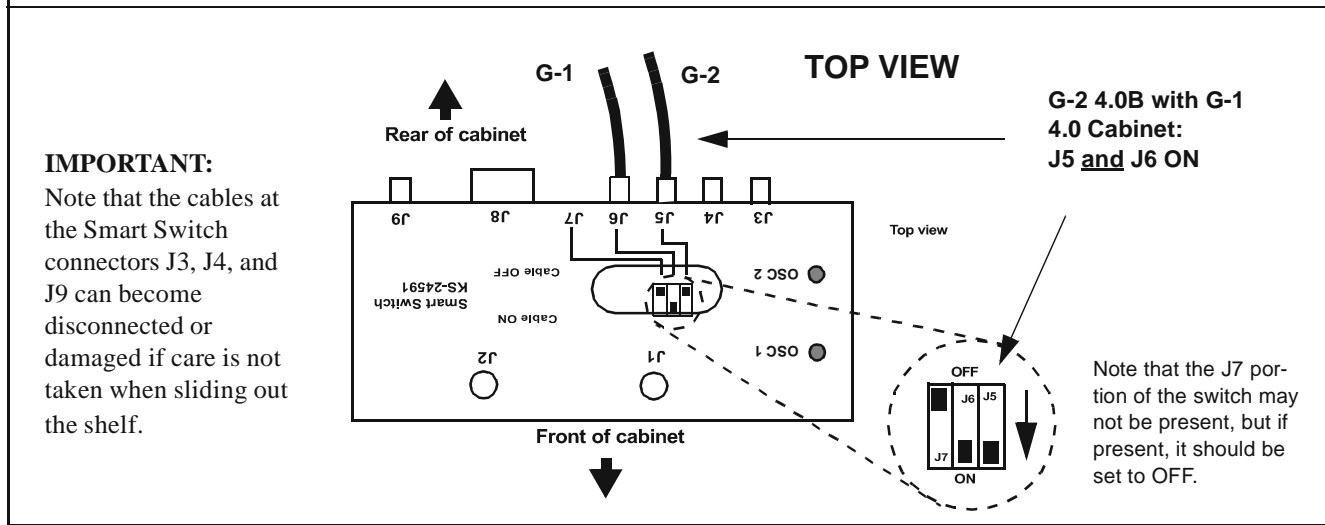
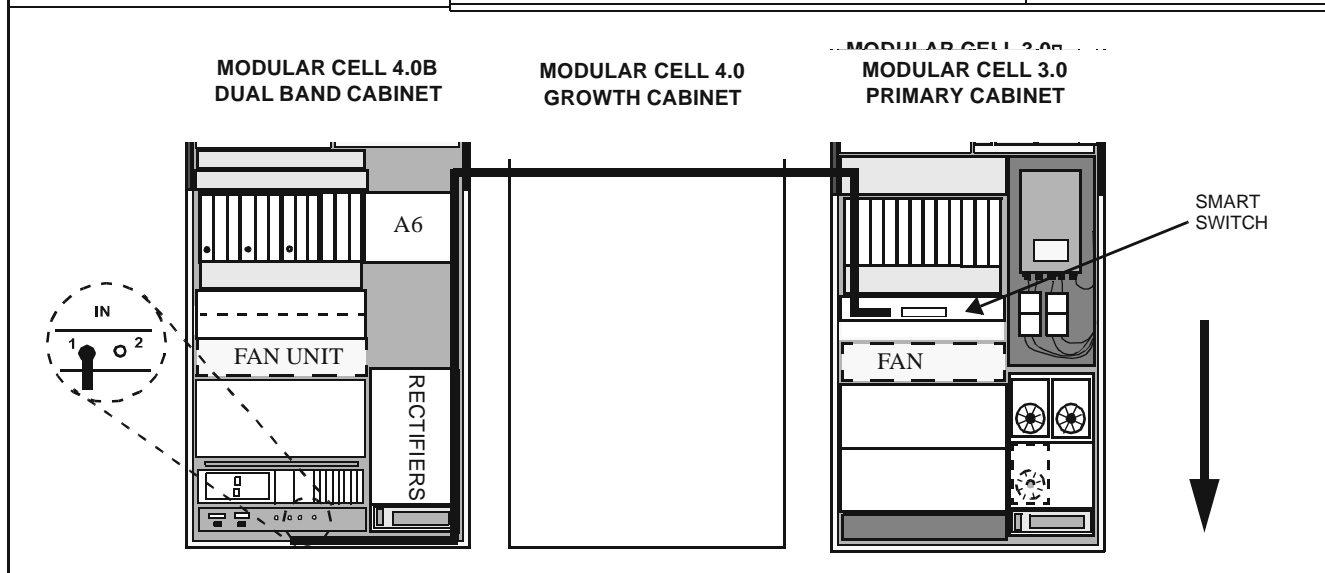
LINE-UP	PRIMARY CABINET CONNECTION	PROCEED TO:
<p>4</p> <div style="display: flex; justify-content: space-around; align-items: center;"> <div style="text-align: center;"> <p>G-2</p>  <p>4.0B (DB)</p> </div> <div style="text-align: center;"> <p>G-1</p>  <p>4.0</p> </div> <div style="text-align: center;"> <p>PRI</p>  <p>3.0</p> </div> </div> <p>4.0B Dual Band with 4.0 G-1 and 3.0 Primary</p>	<p>Connect the 15MHz cable to the J5 port on the "Smart Switch" in the 3.0 primary cabinet as shown in the bottom illustration below.</p>	<p>"Route and connect the GPS cable". Line-up 4</p>

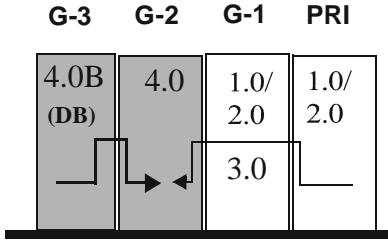

15 MHZ INTER-FRAME CABLE: LINE-UP 5

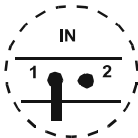
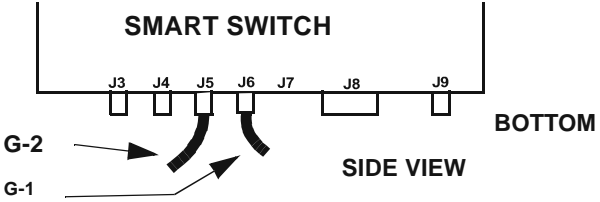
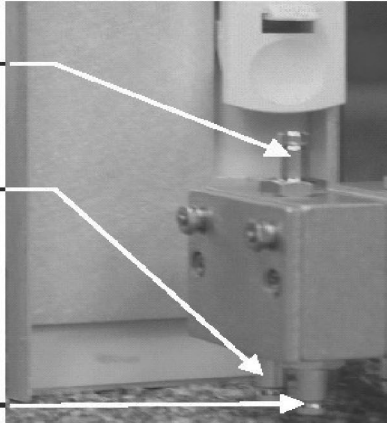
LINE-UP	PRIMARY CABINET CONNECTION	PROCEED TO:
<p>5</p> <p>G-3 G-2 G-1 PRI</p>  <p>4.0B Dual Band with 4.0 G-2, 1.0/2.0/3.0 G-1 and 1.0/2.0 Primary</p>	<p>The existing 15 MHz cable connection at the J5 port of the Smart Switch in the primary cabinet in the 1.0/2.0 primary cabinet remains the same. A kit is supplied to install a 15MHz splitter in the G-2 cabinet. Installation instructions are supplied with the kit. 15MHz connections from all three cabinets are made to this splitter as shown in the illustration below.</p>	<p>"Route and connect the GPS cable". Line-up 5</p>
<div style="display: flex; justify-content: space-around; align-items: flex-start;"> <div style="text-align: center;"> <p>4.0B DUAL BAND G-3 CABINET</p>  </div> <div style="text-align: center;"> <p>4.0 G-2 CABINET</p>  </div> <div style="text-align: center;"> <p>1.0/2.0 PRIMARY CABINET</p>  <p>TOP</p> <p>BOTTOM</p> <p>SIDE VIEW</p> </div> </div>		
<div style="border: 1px solid black; padding: 10px;">  <div style="display: flex; flex-direction: column; gap: 10px; margin-right: 20px;"> <p>From 3.0 Primary Cabinet Smart Switch Port J5</p> <p>Cable to/from 15 MHz IN-1 on Digital Shelf In 4.0 G-2 Cabinet</p> <p>Cable from 15 MHz IN-1 on Digital Shelf In 4.0B Dual Band Cabinet (G-3)</p> </div> </div>		

15 MHz INTER-FRAME CABLE: LINE-UP 6

LINE-UP	PRIMARY CABINET CONNECTION	PROCEED TO:
<p>6</p> <p>G-3 G-2 G-1 PRI</p> <p>4.0B Dual Band with 4.0 G-2, 3.0 G-1, and 3.0 Primary</p>	<p>The existing 15 MHz cable connection at the J5 port of the Smart Switch in the primary cabinet in the 3.0 primary cabinet remains the same. A kit is supplied to install a 15MHz splitter in the G-2 cabinet. Installation instructions are supplied with the kit. 15MHz connections from all three cabinets are made to this splitter as shown in the illustration below.</p>	<p>"Route and connect the GPS cable". Line-up 6</p>

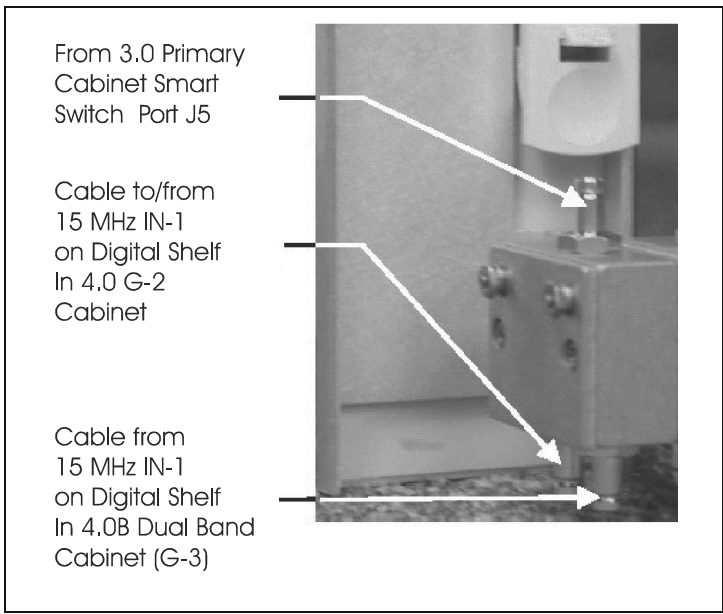
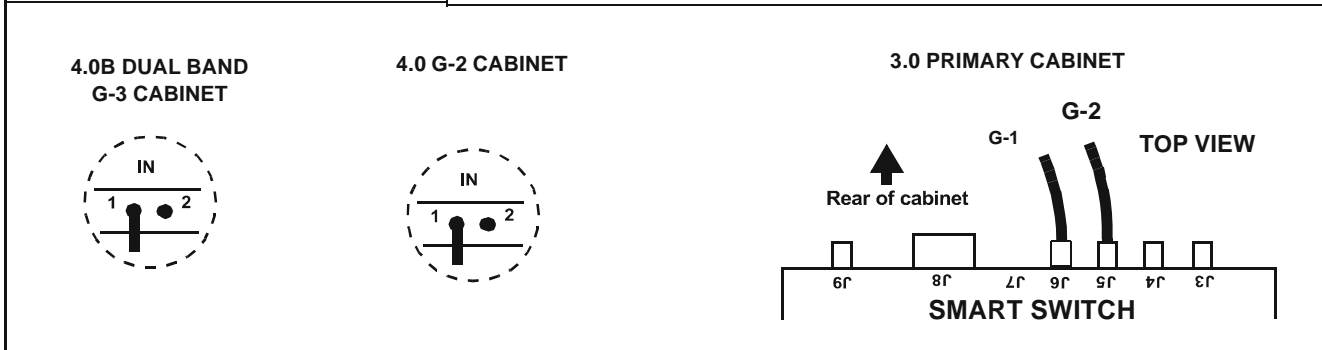

Route and connect the GPS cable

Perform the following steps to route and connect the internal GPS cable from the Modular Cell 4.0B dual band cabinet being installed to the primary cabinet. Refer to the table starting on Page. 6 - 20. for cable routing and connection.

- 1 Determine the number of the cabinet line-up configuration which will be created by the addition of the 4.0B dual band cabinet being installed.
- 2 Using the line-up configuration number, locate the line-up in the table starting on Page. 6 - 20.
- 3 Locate the internal GPS splitter inside the Modular Cell 4.0B dual band cabinet being installed. The GPS splitter is located on the right inside frame near the top of the cabinet.
- 4 Locate the GPS cable coiled inside the Modular Cell 4.0B dual band cabinet being installed. Refer to the applicable line-up in the table starting on Page. 6 - 20. Uncoil only as much of the cable as required to reach the GPS splitter located on the right inside frame near the top of the primary cabinet.

Important! When performing the next steps, route the cables in such a way that they do not interfere with removal / replacement of components, and front door closure. Refer to the applicable line-up in the table starting on Page. 6 - 20.

- 5 In the Modular Cell 4.0B dual band cabinet being installed, route the GPS cable through the RF cable gasket between the cabinets:
 - For line-up 1, route the cable into the primary cabinet
 - For line-ups 2, 3, and 4, route the cable through the G-1 cabinet and into the primary cabinet
 - For line-ups 5 and 6, route the cables through the G-2 and G-1 cabinets and into the primary cabinet

6 Route the cable above the filters in the primary cabinet as shown for the applicable line-up in the table starting on Page. 6 - 20.

7 Wire-tie the cable in place above the filters.

8 In the primary cabinet, at the splitter, remove the terminator from:

- Port 6 on the 1:5 splitter if installing a 4.0B dual band cabinet in the G-2 position
- Port 5 on the 1:5 splitter if installing a 4.0B dual band cabinet in the G-3 position

9 Connect the GPS cable to the GPS splitter in the primary cabinet as follows and as shown for the applicable line-up in the table starting on Page 6 - 20.

- If installing a 4.0B dual band cabinet in the G-2 position, connect the GPS cable to port 6 on the 1:5 splitter
- If installing a 4.0B dual band cabinet in the G-3 position, connect the GPS cable to port 5 on the 1:5 splitter

10 Inside the 4.0B dual band cabinet being installed, coil and tie the slack portion of the GPS cable not routed to the primary cabinet.

11 Using wire ties, secure the GPS cable in place in all cabinets in such a way that it does not interfere with removal / replacement of components, and front door closure.

GPS INTER-FRAME CABLE: LINE-UP 1

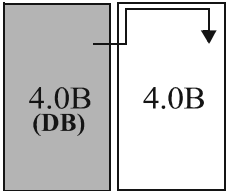
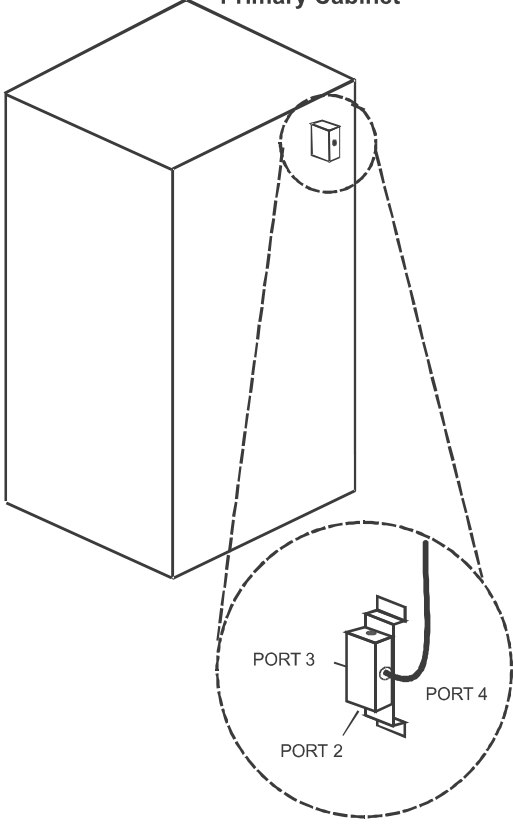
LINE-UP	PRIMARY CABINET CONNECTION	PROCEED TO:
<p style="text-align: center;">G-1 PRI</p>		
<p>1</p>  <p>4.0B Dual Band with 4.0B Primary</p>	<p style="text-align: center;">Modular Cell 4.0/4.0B Primary Cabinet</p>  <p style="text-align: center;">ATTACH THE GPS CABLE TO PORT 4 ON THE 1:3 SPLITTER</p>	<p>Inter-frame cable routing and connection is complete for Line-up 1</p>

GPS INTER-FRAME CABLE: LINE-UP 2

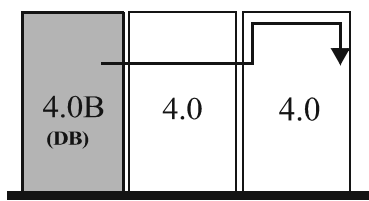
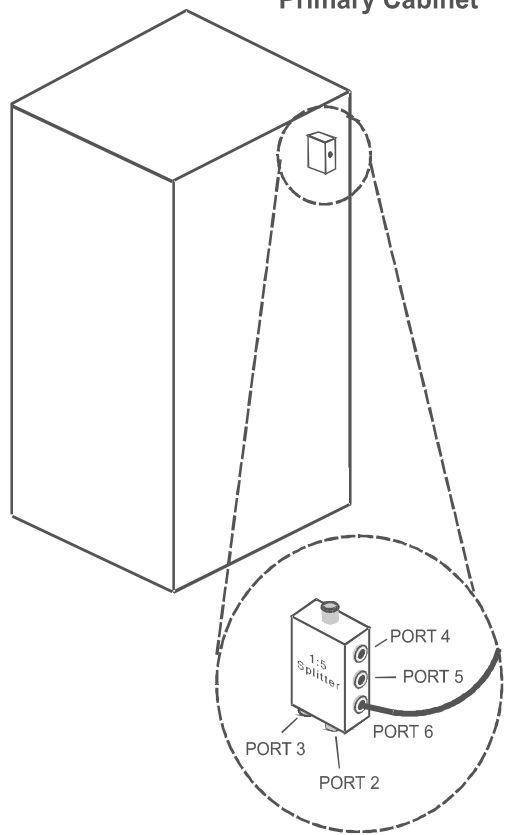
LINE-UP			PRIMARY CABINET CONNECTION	PROCEED TO:
G-2	G-1	PRI		
<p>2</p>  <p>4.0B Dual Band with 4.0 G-1 and 4.0 Primary</p>			<p>Modular Cell 4.0 Primary Cabinet</p>  <p>ATTACH THE GPS CABLE TO PORT 6 ON THE 1:5 SPLITTER</p>	<p>Inter-frame cable routing and connection is complete for Line-up 2</p>

GPS INTER-FRAME CABLE: LINE-UP 3

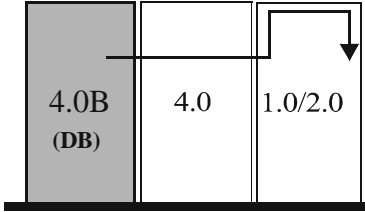
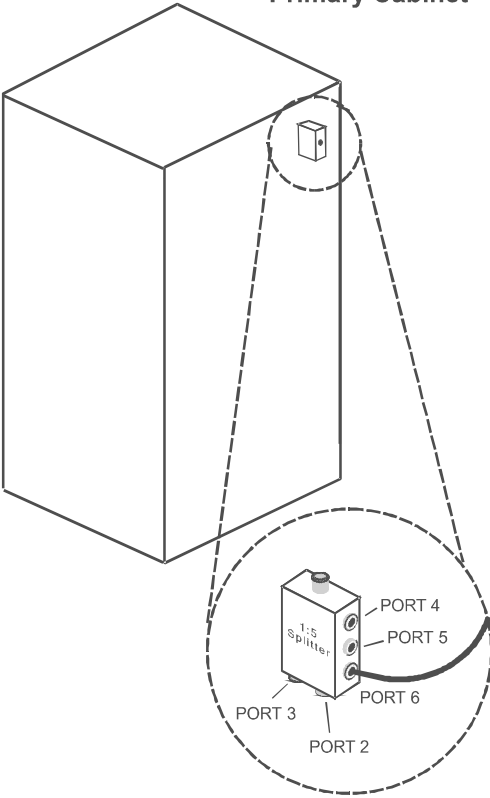
LINE-UP			PRIMARY CABINET CONNECTION	PROCEED TO:
G-2	G-1	PRI		
<p>3</p>  <p>4.0B Dual Band with 4.0 G-1 and 1.0/2.0 Primary</p>			<p>Modular Cell 1.0/2.0 Primary Cabinet</p>  <p>ATTACH THE GPS CABLE TO PORT 6 ON THE 1:5 SPLITTER</p>	<p>Inter-frame cable routing and connection is complete for line-up 3</p>

GPS INTER-FRAME CABLE: LINE-UP 4

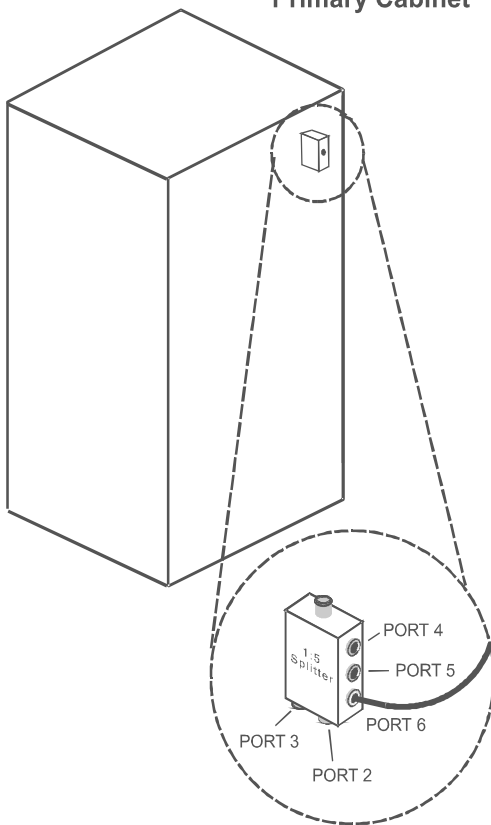
LINE-UP			PRIMARY CABINET CONNECTION	PROCEED TO:
G-2	G-1	PRI		
<p>4</p>  <p>4.0B Dual Band with 4.0 G-1 and 3.0 Primary</p>			<p>Modular Cell 3.0 Primary Cabinet</p>  <p>ATTACH THE GPS CABLE TO PORT 6 ON THE 1:5 SPLITTER</p>	<p>Inter-frame cable routing and connection is complete for line-up 4</p>

GPS INTER-FRAME CABLE: LINE-UP 5

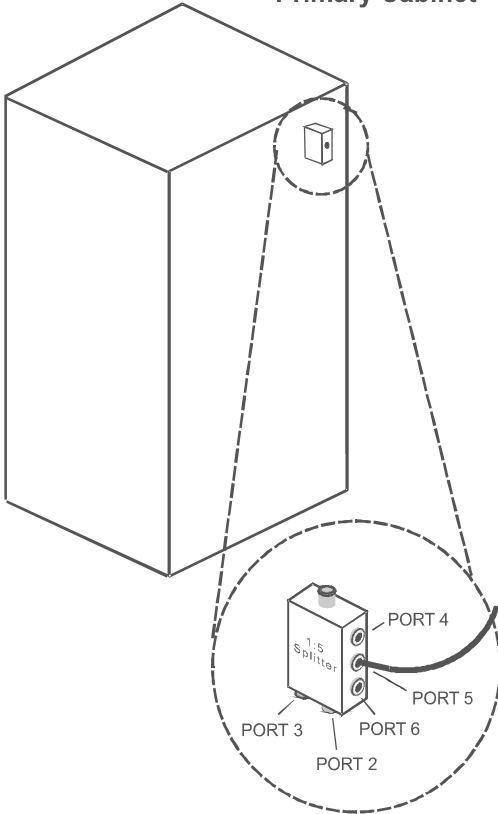
<p>LINE-UP</p> <p>G-3 G-2 G-1 PRI</p>	<p>PRIMARY CABINET CONNECTION</p>	<p>PROCEED TO:</p>				
<p>5</p> <table border="1" data-bbox="146 556 527 751"> <tr> <td>4.0B (DB)</td> <td>4.0</td> <td>1.0/ 2.0 3.0</td> <td>1.0/ 2.0</td> </tr> </table> <p>4.0B Dual Band with 4.0 G-2, 1.0/2.0/3.0 G-1 and 1.0/2.0 Primary</p>	4.0B (DB)	4.0	1.0/ 2.0 3.0	1.0/ 2.0	<p>Modular Cell 1.0/2.0 Primary Cabinet</p>  <p>ATTACH THE GPS CABLE TO PORT 5 ON THE 1:5 SPLITTER</p>	<p>Inter-frame cable routing and connection is complete for line-up 5</p>
4.0B (DB)	4.0	1.0/ 2.0 3.0	1.0/ 2.0			

GPS INTER-FRAME CABLE: LINE-UP 6

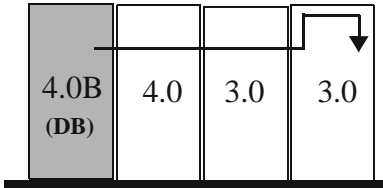
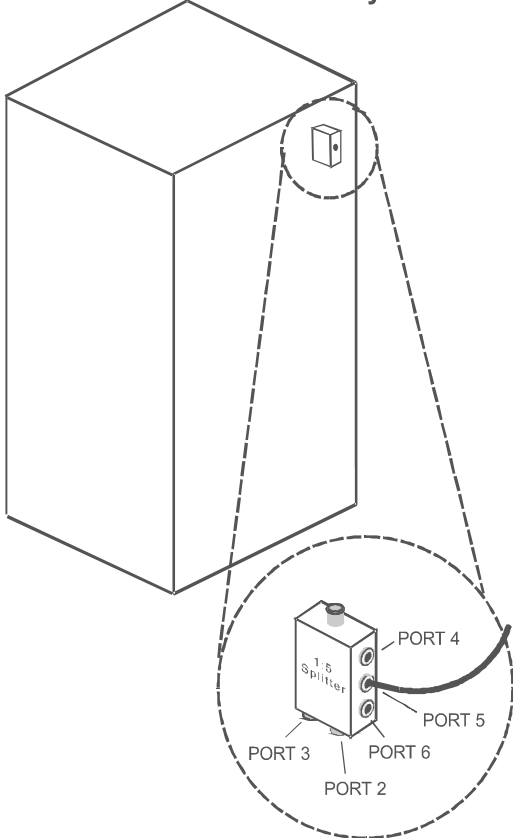
LINE-UP	PRIMARY CABINET CONNECTION	PROCEED TO:
G-3 G-2 G-1 PRI		
<p>6</p>  <p>4.0B Dual Band with 4.0 G-2, 3.0 G-1, and 3.0 Primary</p>	<p>Modular Cell 3.0 Primary Cabinet</p>  <p>ATTACH THE GPS CABLE TO PORT 5 ON THE 1:5 SPLITTER</p>	<p>Inter-frame cable routing and connection is complete for line-up 6</p>

Line-up table

Important! Not all of the line-ups listed in the table that follows are existing configurations.

Line-up table

PRI.	G-1	G-2	G-3	SINGLE BAND CARRIERS	DUAL BAND CARRIERS	LINE-UP NUMBER
4.0B 850	4.0B PCS Dual Band	N/A	N/A	Up to eight 850 carriers Primary	1 to 11 PCS G-1	1
4.0B PCS	4.0B 850 Dual Band	N/A	N/A	Up to eleven PCS carriers Primary	1 to 8 850 G-1	
4.0 850	4.0 850	4.0B PCS Dual Band	N/A	1 to 8 850 Primary and G-1	1 to 11 PCS G-2	2
1.0/2.0 850	4.0 850	4.0B PCS Dual Band	N/A	1 to 7, or 8 850 Primary and G-1	1 to 11 PCS G-2	3
3.0 850	4.0 850	4.0B PCS Dual Band	N/A	1 to 7, or 8 850 Primary and G-1	1 to 11 PCS G-2	4
1.0/2.0 850	1.0/2.0/3.0 850	4.0 850	4.0B PCS	1 to 8 850 Primary, G-1 & G-2	1 to 11 PCS G-3	5
3.0 850	3.0 850	4.0 850	4.0B PCS	1 to 8 850 Primary, G-1 & G-2	1 to 11 PCS G-3	6



7 Finishing the installation

Overview

Purpose This chapter provides information for finishing the installation of the Modular Cell 4.0B primary and dual band cabinets, as well as WNG24-BC battery cabinets. Information for finishing the installation of the EZBFo battery frames is included in Appendix A.

Contents This chapter contains the following section.

<u>Finish the installation of the Modular Cell 4.0B cell site cabinets</u>	7 - 2
----------------------------------------------------------------------------	-------

Finish the installation of the Modular Cell 4.0B cell site cabinets

Overview

Purpose This section provides information and procedures to finish the installation of the Modular Cell 4.0B primary and dual band cabinets, as well as the WNG battery cabinet.



Check of antenna connection status 7 - 3

Power-up and system test 7 - 4

How to finish the installation of the Modular Cell 4.0B primary and dual band cabinets 7 - 5

How to finish the installation of a first or second WNG24-BC battery cabinet 7 - 19

Check of antenna connection status

Verify GPS antenna connection

Verify that the GPS antenna is properly connected, as outlined in Chapter 3 of this document. Verify that it meets all of the appropriate guidelines in accordance with the following documents.

Flexent® Modular Cell 4.0/4.0B Outdoor Site Preparation Guidelines, document number 401-703-413

- *Grounding and Lightning Protection Guidelines for Lucent Technologies Network Wireless System Cell Sites*, document number 401-200-115

Important! The GPS antenna must be connected to the Modular Cell 4.0B primary cabinet prior to " Initial start up and system test". Refer to Chapter 3. Do not connect RF antenna jumper cables.

Verify RF antennas not connected

The RF antennas must not be connected to the primary or dual band cabinets until power-up and system test has been performed.

Power-up and system test

Perform power-up and system test

Following installation of the Modular Cell 4.0B primary or dual band cabinets, the system should be tested before being put into operation. System test and integration procedures are not covered in this installation document. This information is contained in *Lucent Technologies Installation Engineering Handbook 238*. Consult the specific reference below. Power-up and system test can be performed if the following tasks are completed.

- All cabinets are installed as specified in this document.
- The GPS antenna cable is connected.
- RF antenna jumper cables are not connected to the Modular Cell 4.0B primary or 4.0B dual band cabinets.

Important! Refer to *Lucent Technologies Installation Engineering Handbook 238* for procedures for power-up and stand-alone testing. Section 221 is for power-up.

How to finish the installation of the Modular Cell 4.0B primary and dual band cabinets

Overview This section covers the following procedures.

<u>Test and connect the internal battery cables (if applicable)</u>	7 - 5
<u>Connect the unterminated end of the RF antenna jumper cables to the Modular Cell 4.0B primary or 4.0B dual band cabinet</u>	7 - 8
<u>Connect a terminated end of the outdoor RF antenna jumper cables to the Modular Cell 4.0B primary or 4.0B dual band cabinet</u>	7 - 12
<u>Connect RF antenna jumper cables to the antenna cables</u>	7 - 15
<u>Replace / close all access panels and doors</u>	7 - 18

This section provides instructions for finishing the installation of the Modular Cell 4.0B primary and dual band cabinets.

Test and connect the internal battery cables (if applicable)

The batteries required for a given cabinet configuration are shipped already installed in the Modular Cell 4.0B primary or 4.0B dual band cabinets which are equipped with integrated power.

- 1 Disconnect the battery connectors. Refer to the figure below.

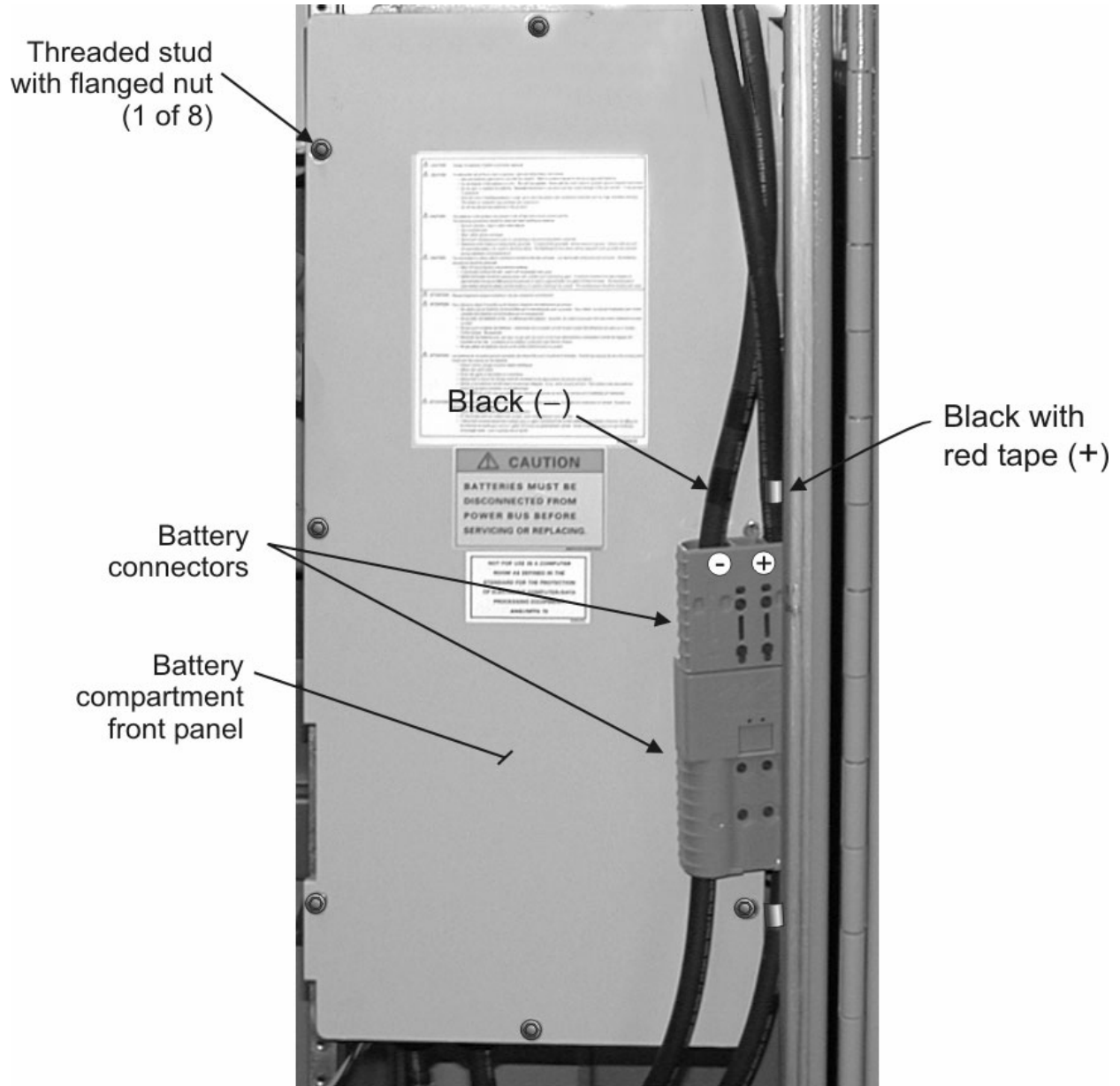

- 2 Measure the voltage at the battery cable connector to determine that the polarity is correct. Refer to the figure below.

- Digital meter - no symbol or positive symbol = **correct** connection.
- Digital meter - negative symbol = incorrect connection.
- Analog meter - positive deflection = **correct** connection.
- Analog meter - negative deflection = incorrect connection.

All of the above assume correct meter lead connection.

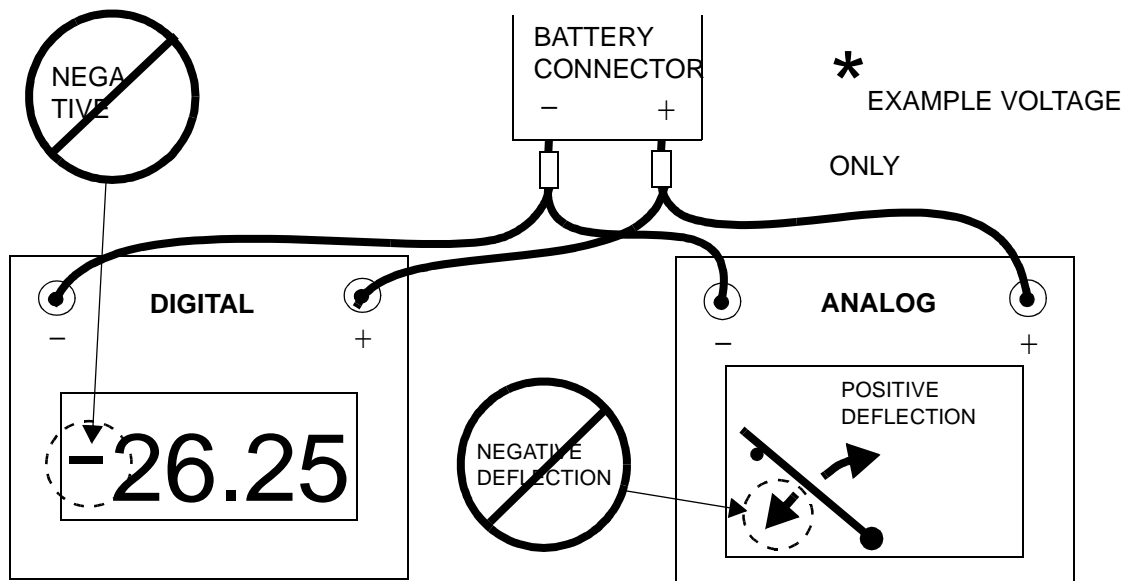

3 Repeat the test in the previous step, for the battery connector to be plugged into the one already tested.

4 Rewire any incorrectly wired battery cables. Use the procedure Install batteries in a Modular Cell 4.0B cabinet, in Chapter 5, Page 5 - 5.

Important! Before performing the next step, be sure that AC power is connected to the Modular Cell 4.0B or 4.0B dual band cabinet, all AC circuit breakers are ON, and AC power is turned on at the main panel.

5 Connect the battery connectors together.

Connect the unterminated end of the RF antenna jumper cables to the Modular Cell 4.0B primary or 4.0B dual band cabinet

Important! If both ends of the antenna jumper cables are terminated, skip to Connect a terminated end of the outdoor RF antenna jumper cables to the Modular Cell 4.0B primary or 4.0B dual band cabinet on Page 7 - 12 to continue the installation.

The Modular Cell 4.0B primary or 4.0B dual band cabinet requires six RF antenna jumper cables. The jumper cables may be unterminated on one end. This end will be terminated and attached to the RF connectors on the applicable Modular Cell cabinet, which is reached through the entry openings on the antenna cable cover of the cabinet. The jumper cables are terminated on the other end with a 7/16-inch straight male DIN connector. This end will connect directly to the surge suppressors on each RF antenna at the outdoor cable rack support. Refer to the figure on Page 7-15

Use the following procedure to connect the RF antenna jumper cables to the Modular Cell 4.0B primary or 4.0B dual band cabinet.

-
- 1 Cut the unterminated end of the cable to the correct length. Allow adequate slack for a drip loop and cut the cable to the correct length. Refer to the figure on Page 7-15.
-
- 2 Label both ends of each RF antenna jumper cable: S1D0, S1D1, S2D0, S2D1, S3D0, S3D1.

Important! When performing the next step, do not prepare the unterminated end of the cable for the subsequent attachment of the connector. The sharp edges that would result will damage the rubber boot when it is slid onto the cable. Refer to the figure on Page 7-9.

-
- 3 Sprinkle talcum powder on the inside and outside of the tapered (small) end of the boot (because it will turn inside-out). Slide the boot onto the antenna cable (tapered end towards antenna). Position the boot approximately 8 inches from the end of the cable. Refer to the figure below.

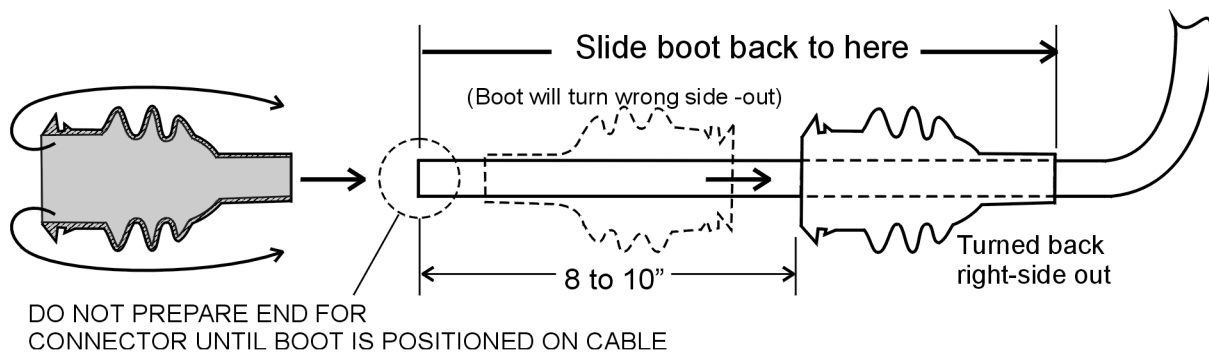

-
- 4 Prepare the end of the cable for the DIN connector. Use the appropriate stripping tool part number provided in Chapter 1. Refer to Tools, supplies, and parts required (master list) on Page 1 - 31.
-
- 5 Terminate the end of the cable with the male DIN connector provided.
-
- 6 Insert the connector end of the jumper cables through the applicable openings in the antenna cable cover.

- 7 Connect the RF antenna jumper cable to the applicable connector on the Modular Cell 4.0B primary or 4.0B dual band cabinet. Refer to the figure below.

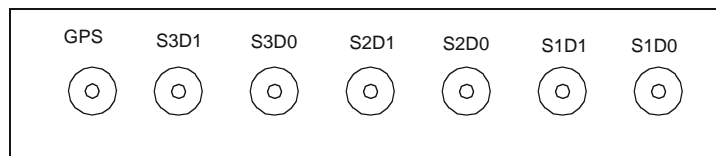

- 8 Slowly slide the boot towards the cabinet and install it into the opening on the antenna cover. Refer to the figure below.

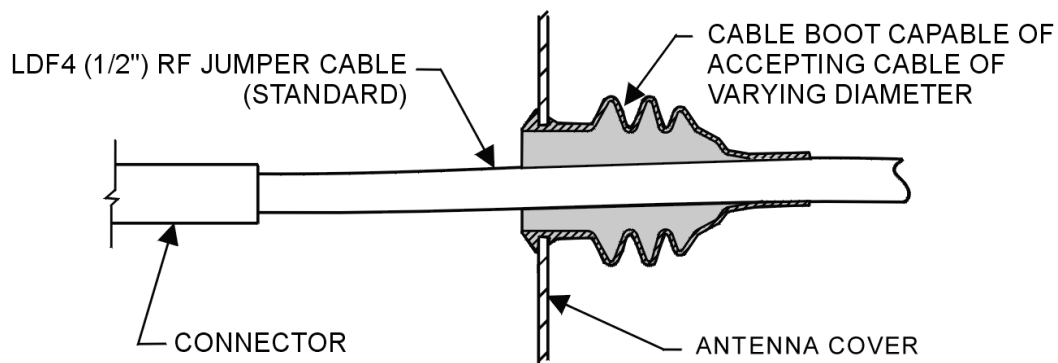

- 9 Pull the boot back towards you to ensure that the lip of the boot is fully seated.

- 10 Repeat Steps 2 through 9 for all antenna jumper cables.

Important! When connecting / disconnecting a Lucent RF coaxial jumper cable assembly to/from any fixed panel mounted 7-16 DIN female receptacle, it is highly recommended that the cable assembly be connected/disconnected as shown in the figure below. Please note that the mating receptacle is not shown because it is a fixed and secured interface. Wrenches for connecting/ disconnecting the mating RF coaxial jumper cable's 7-16 DIN male plug, which is equipped with a rotating coupling nut, are required.

- 11 Torque the antenna jumper cable connections at the applicable Modular Cell cabinet to 221 in.-lb. (25 Nm) using the method shown in the figure below.

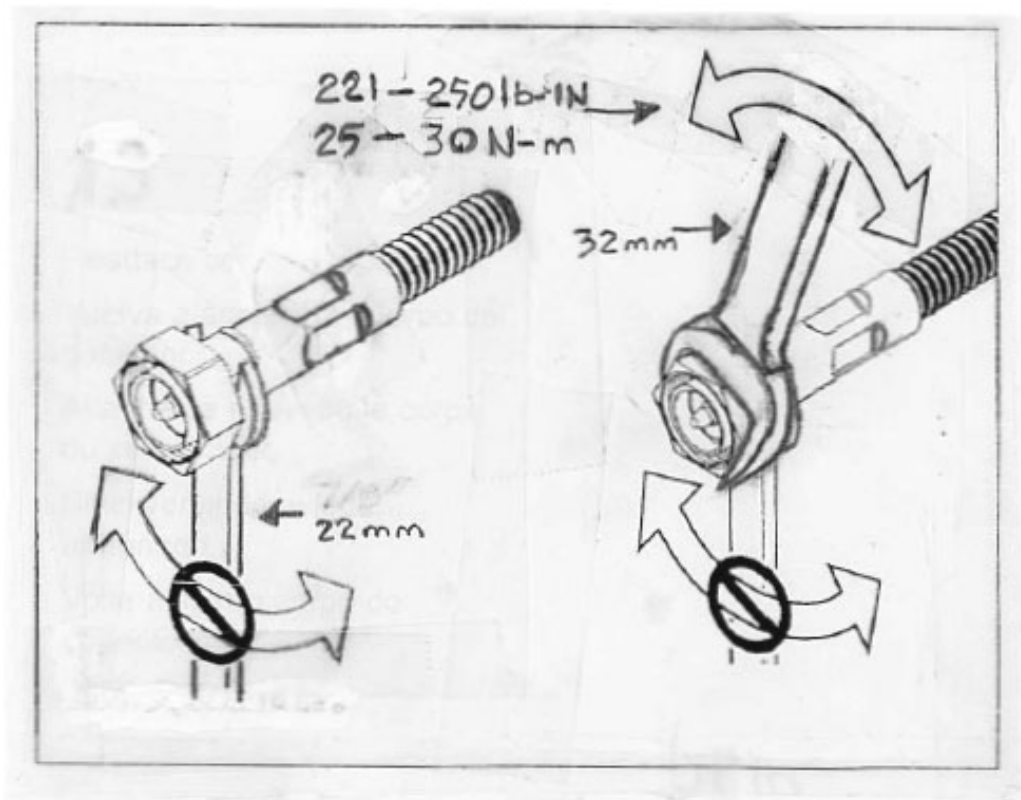

- 12 Replace the top panel on the antenna cable cover. Torque the tamper-proof screws to 15-20 in.-lb. (1.7 - 2.3 Nm).

Connect a terminated end of the outdoor RF antenna jumper cables to the Modular Cell 4.0B primary or 4.0B dual band cabinet

Important! If the antenna jumper cables have already been connected at the Modular Cell primary or dual band cabinet, skip to [Connect RF antenna jumper cables to the antenna cables](#) on Page 7 - 15 to continue the installation.

The Modular Cell 4.0B primary or 4.0B dual band cabinet require six RF antenna jumper cables. These jumper cables may be terminated on both ends with 7/16-inch straight DIN connectors. One end will be attached to the RF connectors on the Modular Cell cabinet, which is reached through the entry openings on the antenna cable cover of the cabinet. The other end will connect directly to the surge suppressors on each RF antenna at the outdoor cable rack support. Refer to the figure on Page 7-15.

Use the following procedure to connect the RF antenna jumper cables to the Modular Cell 4.0B primary or 4.0B dual band cabinet.

- 1 Label both ends of each RF antenna jumper cable: S1D0, S1D1, S2D0, S2D1, S3D0, S3D1.
- 2 Obtain a rubber boot and split it as shown in the figure below.
- 3 Slip the boot over the antenna cable (tapered end towards antenna). Position the boot approximately 8 to 10 inches from the end of the cable. Refer to the figure below.

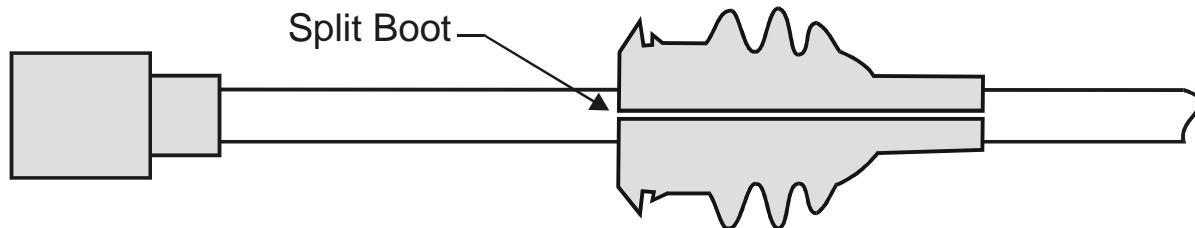

BOTTOM VIEW