

**Prepare the AC power module (ACPDA) for connection of the AC utility wires**



**WARNING**  
**Energy Hazard!**

*When performing the following procedure, power must be OFF at the main AC panel. Failure to observe this fact and the safety warnings may lead to bodily injury and property damage.*

Perform the following steps to prepare the AC power module for connection of the AC utility wires.

- 1 Turn off all circuit breakers on the front of the AC power module in the primary or dual band cabinet. Refer to the figure below.

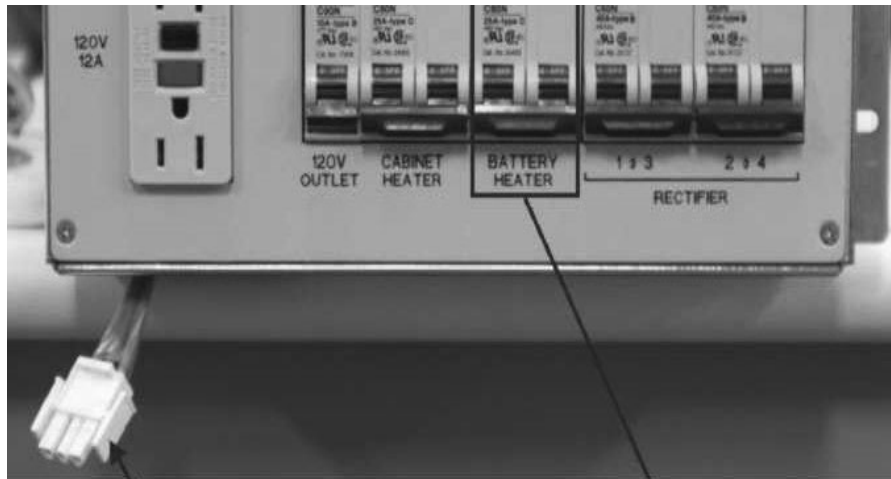

- 
- 2 Remove the lower rear panel from the cabinet. Refer to the figure below.
- 
- 3 Fully loosen the two AC access cover thumb screws and remove the cover. Refer to the figure below.

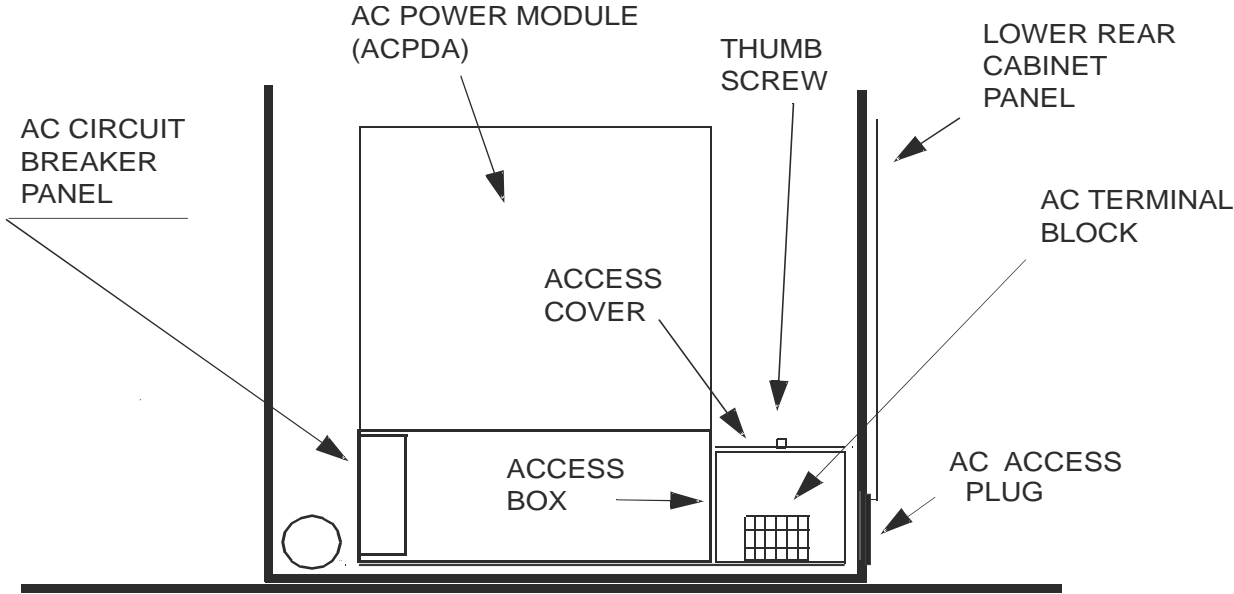

**RIGHT SIDE VIEW**

**Install a 2-inch flexible conduit fitting on the primary or dual band cabinet**

Perform the following steps to install a 2-inch flexible conduit fitting on the primary or dual band cabinet.

- 
- 1 Remove the access plug from the AC access opening. It will not be reused.

**Important!** When performing the next step, a 2-inch sealing ring must be inserted between the fitting and the cabinet wall (if the fitting is not equipped with a seal.).

- 
- 2 Insert the fitting into the opening as shown in the figure below.

- 
- 3 Place the locking nut (supplied with the fitting) between the inside cabinet wall and the wall (if present) of the ACPDA access box as shown in the figure below.

- 
- 4 Thread the fitting into the nut and tighten.

**2" SEAL RING SUPPLIED WITH FITTING**  
(Locate between fitting and Cabinet wall)



**2" FLEXIBLE CONDUIT FITTING (CUSTOMER PROVIDED)**

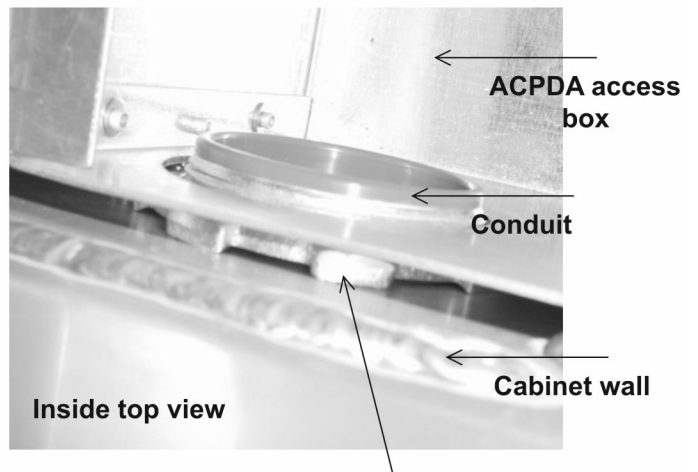

**2" CONDUIT NUT SUPPLIED WITH FITTING**  
(Install between cabinet wall and ACPDA wall)

**Connect the flexible conduit between the existing metal conduit and the fitting at the primary or dual band cabinet**

Perform the following steps to connect a flexible conduit between the existing metal conduit and the flexible fitting previously installed at the primary or dual band cabinet. The metal conduit was installed as part of site preparation.

- 1 Locate the metal conduit for the AC wires, and, if installed, remove the end cap from the metal conduit.

**Important!** When performing the next two steps, a junction box may be installed between the metal conduit and the flexible conduit to facilitate the routing of AC wires to a dual band cabinet. Refer to the figure on Page 4 - 11 for the location.

- 2 Pull the AC wires through the flexible conduit and then connect the flexible conduit to the metal conduit. Refer to the figure on Page 4 - 11 for the connection.

- 3 At the Modular Cell 4.0B cabinet, assemble the parts as shown in the figure below, and thread the AC wires into the primary or dual band cabinet. Note that if already stripped, the individual wires must be taped before threading them into the cabinet. Refer to the figure below for assembly.

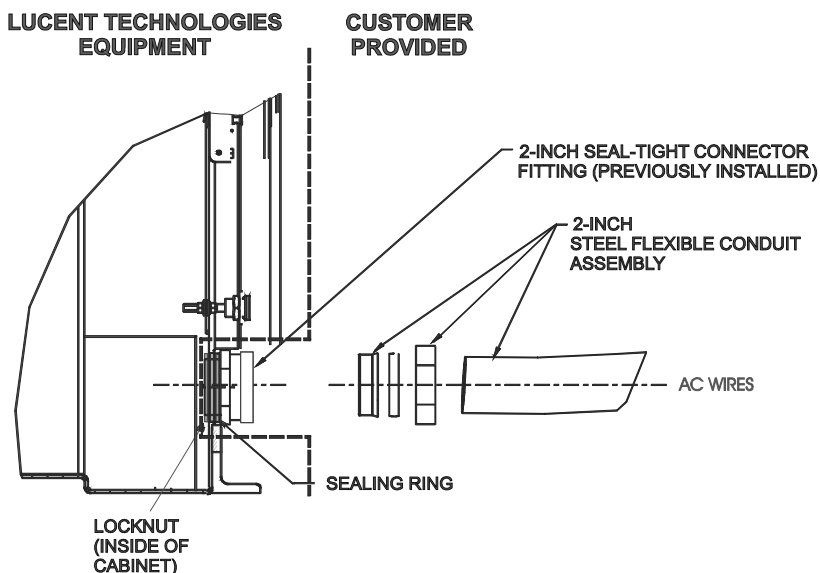

- 4 Thread the end of the flexible conduit assembly onto the previously installed fitting, and tighten. Refer to the figure on Page 4 - 10.

**Important!** For a profile view of the sound muffler, refer to Chapter 1, Modular Cell 4.0B cabinet side view 1 on Page 1 - 26. For alternate cable routings refer to Chapter 1, Modular Cell 4.0B cabinet side view 2 on Page 1 - 27.

- 5 Refer to the figure below for the completed conduit installation.

THE OPTIONAL REAR HEAT EXCHANGER, MOUNTED ON THE REAR OF THE CABINET, IS NOT SHOWN IN THIS VIEW. REFER TO Heat exchanger and solar shield configurations for Modular Cell 4.0B cabinets ON PAGE 2 - 69 FOR HEAT EXCHANGER APPLICATIONS

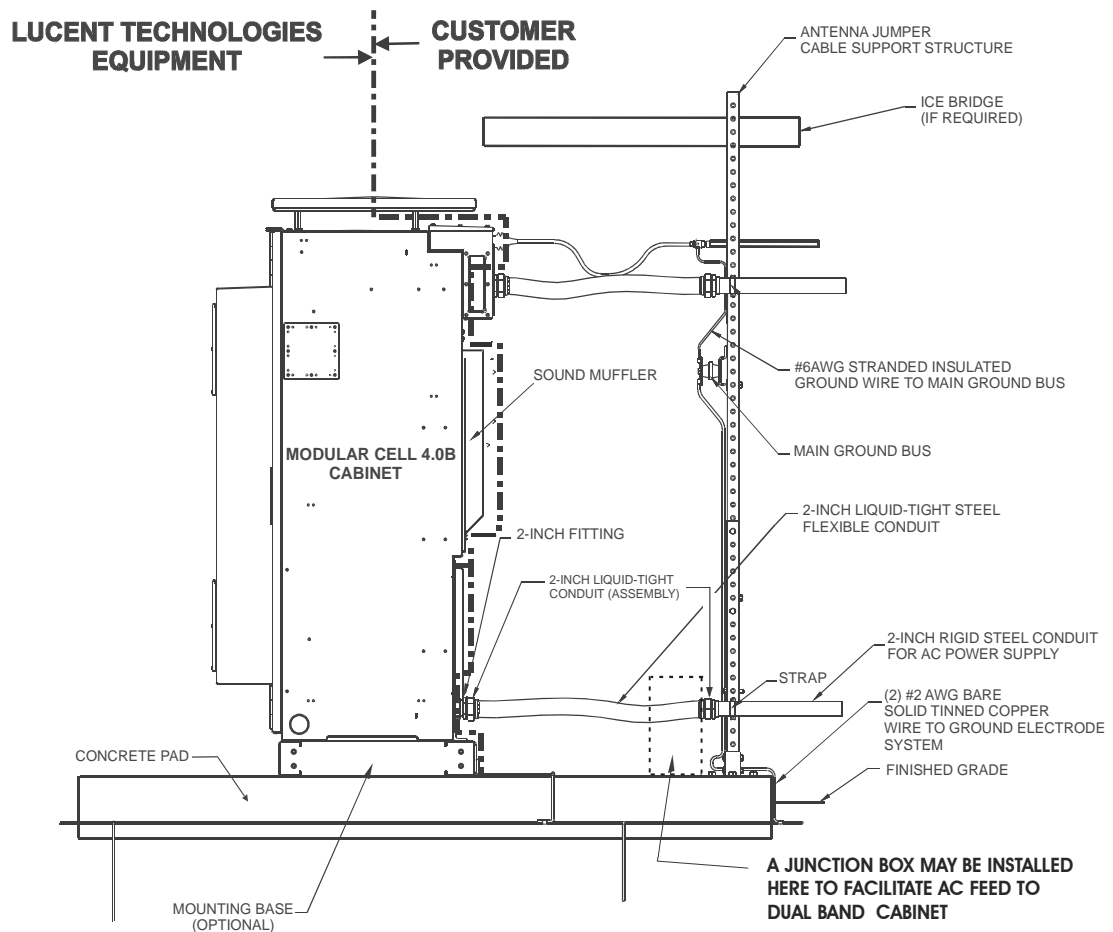

### Route and connect the AC utility wires in the primary or dual band cabinet

This procedure module provides instructions for the connection of the AC utility power cable to the Modular Cell 4.0B primary or dual band cabinet. Since this procedure may be performed by a licensed electrician (depending upon local regulations) these steps are supplied for reference only.

When the AC utility connections are to be performed by a licensed electrician, this activity must be coordinated with the work of the cabinet installers in order to avoid unnecessary delays. Perform the following steps to route and connect the AC utility wires in the primary or dual band cabinet.

- 1 Route the AC wires to the AC terminal block in the access box. Refer to the figure below.
- 2 Cut the wires to the correct length, while leaving adequate slack. Then, strip the individual wires to expose 5/8-inch.

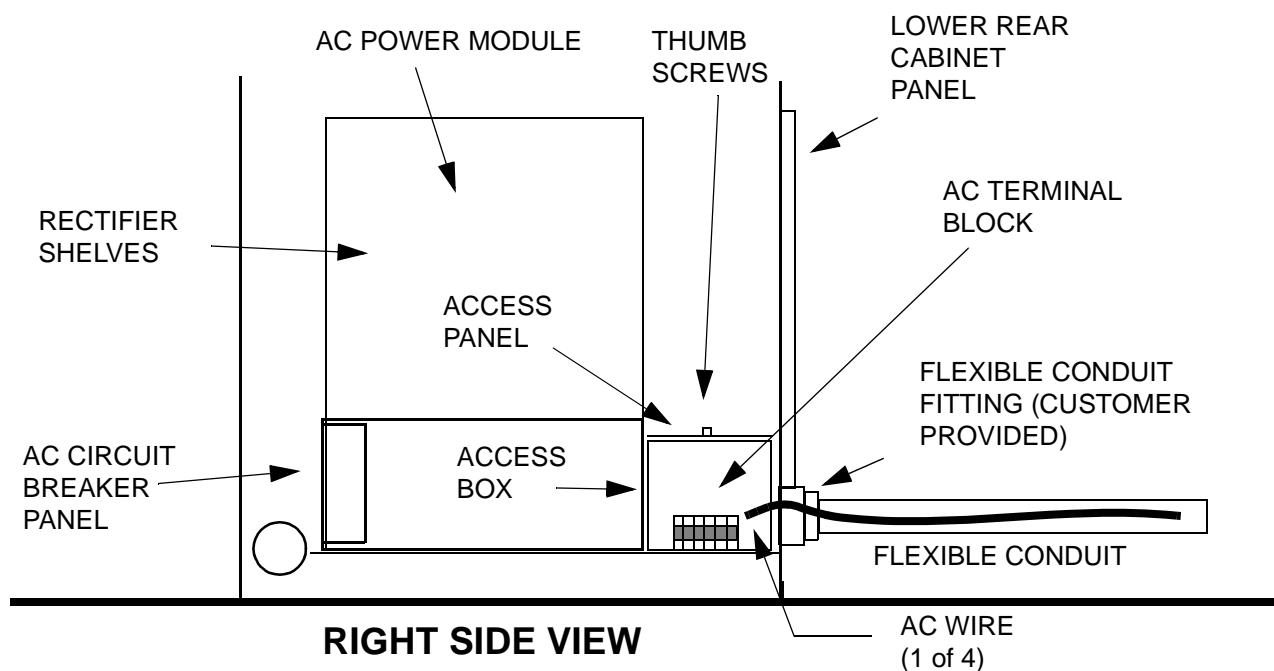

- 3 Fully loosen the applicable input screws. Refer to the figure below.
- 4 Loosen the screws and connect the AC utility input wires to the terminal block. Refer to the left-hand figure below for connection references.
  - Refer to the left-hand figure below for connection references.
  - Refer to the right-hand figure below for another view of the finished connections.

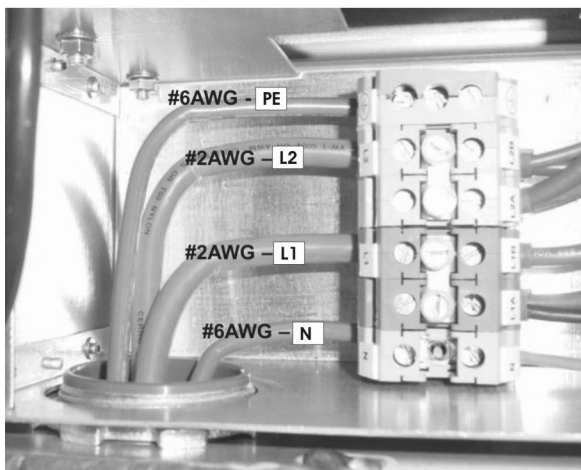

Top view

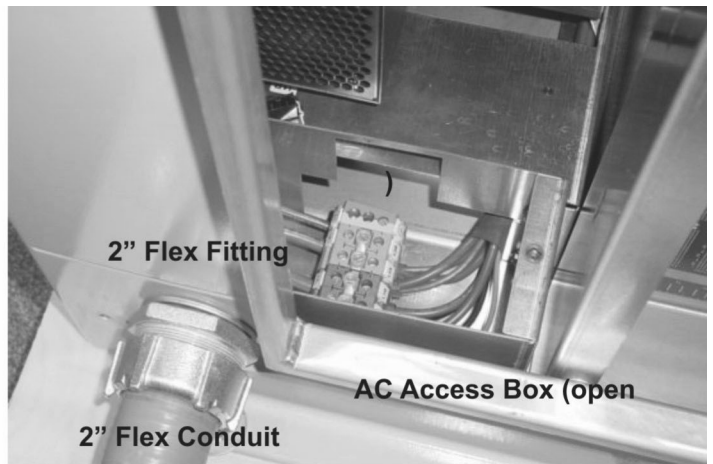

Top view

- 5 Tighten the screws.
- 6 Replace the AC access box cover and the lower rear panel on the primary or dual band cabinet.
- 7 Proceed to the following page, chapter, or appendix depending upon what remains to be installed:
  - WNG battery cabinet: continue on the next page
  - EZBFo battery frame: skip to Appendix A
  - No battery cabinet or frame: skip to Chapter 6 for dual band cabinets and Chapter 7 for primary cabinets
  - Customer supplied power: skip to Appendix B

# How to make the cable connections between the first WNG battery cabinet and the 4.0B primary cabinet

## Overview

---

**Purpose** This section contains instructions for making the cable connections between the first WNG battery cabinet and the Modular Cell 4.0B primary cabinet.

**Important!** If installing an EZBFo battery module, proceed to Appendix A.

**Important!** If installing 66ECv2 battery cabinets, refer to How to install 60ECv2 battery cabinets with a 4.0B primary cabinet with integrated power (reference) on Page 4 - 71 for instruction references.

This section contains the following procedures. It is recommended that these procedures be performed during a maintenance window, when the primary cabinet does not have power applied.

<u>How to install the cable interface panel and identify the cables</u>	4 - 15
<u>How to connect the +24-VDC cables in the first WNG24-BC battery cabinet</u>	4 - 18
<u>How to route and connect the fan power/alarm, fuse alarm, and intrusion alarm cables in the first WNG24-BC battery cabinet</u>	4 - 24
<u>How to connect the alarm, thermal probe and fan power/alarm cables in the Modular Cell 4.0B primary cabinet</u>	4 - 32
<u>How to route and connect the battery cabinet AC power cable in the Modular Cell primary cabinet</u>	4 - 39



# How to install the cable interface panel and identify the cables

---

## Install the cable interface panel



### WARNING

#### Electrical Shock Hazard and Damage to Equipment

*In order to prevent an accidental shock hazard, or damage to equipment, the DC cables, which are attached to the cable interface panel, are shipped with heat shrink tubing on both ends of each cable. If the Modular Cell 4.0B primary cabinet is powered up, the four DC terminal lugs on both ends of the DC cables must have this heat shrink tubing, or be taped prior to installing the cable interface panel in the following steps.*

*When performing the following procedure, power should not be applied to the Modular Cell 4.0B primary cabinet.*

Perform the following steps to install the cable interface panel. Refer to the figure on Page 4 - 17. Note that the alarm, fan power, and thermal probe cables are not shown in the figure.

- 1 Inside the WNG24-BC battery cabinet, remove the two temporary self-tapping screws from the DC cable support.

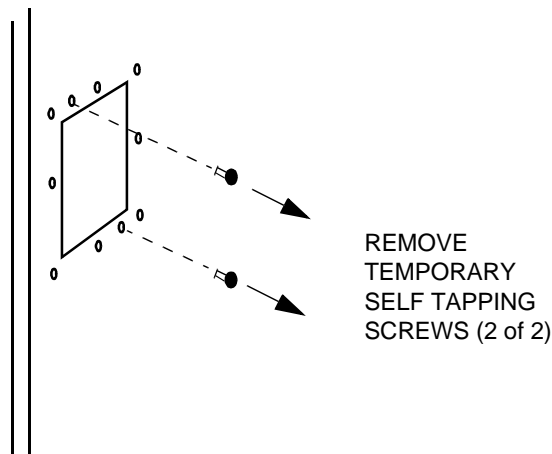

- At the Modular Cell 4.0B primary cabinet, loosen the screw(s) and open the door of the high power distribution assembly (HPDA). Refer to the figure below for the HPDA.

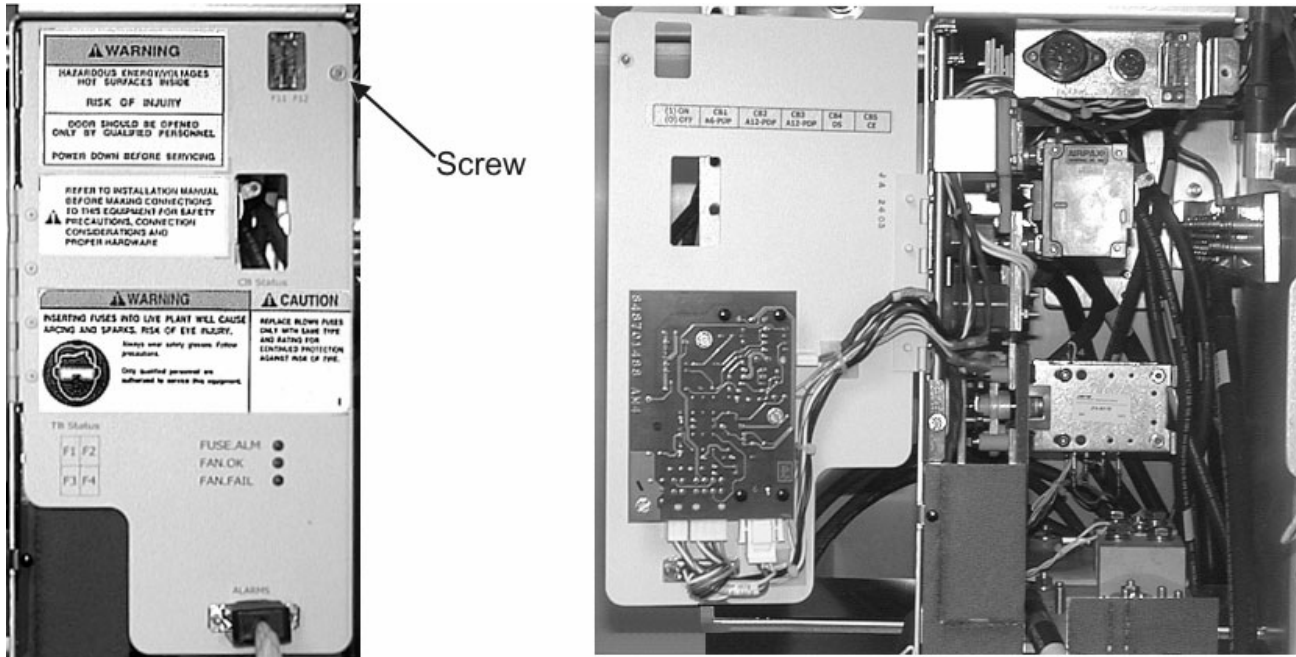

**Important!** When performing the next step, the side of the cable interface panel with a gasket, should face the primary cabinet.

- From inside the WNG24-BC battery cabinet, thread the four pair of DC cables (4 positive and 4 return) and the alarm/fan power/thermal probe harness through the opening into the Modular Cell 4.0B primary cabinet. Do not connect any cables at this time.

- From inside the Modular Cell 4.0B primary cabinet, install the supplied shorter screws (35 mm) through the side wall of the cabinet, the cable support, and into the interface panel.

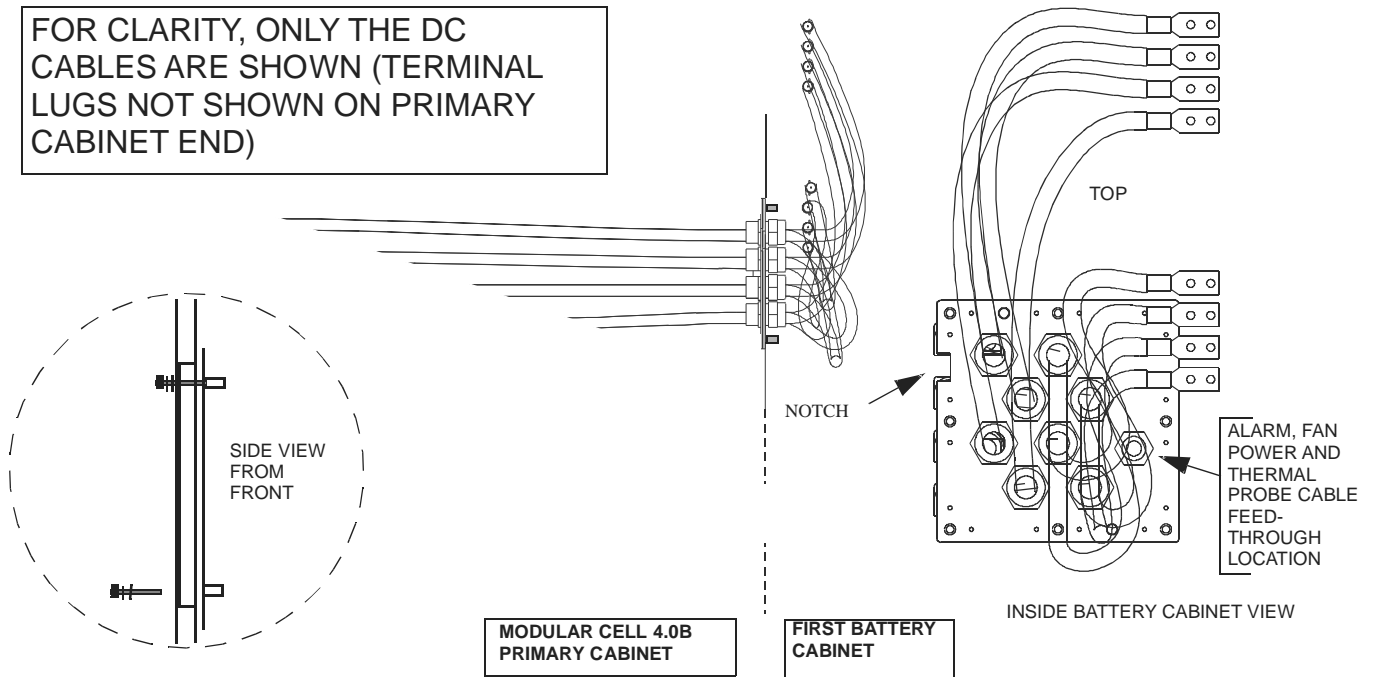

**Important!** When performing the next step, the screws must be tightened to a point that no gasket material is visible around the cable support.

- Refer to the figure below and tighten the cable support screws using the tightening sequence shown.

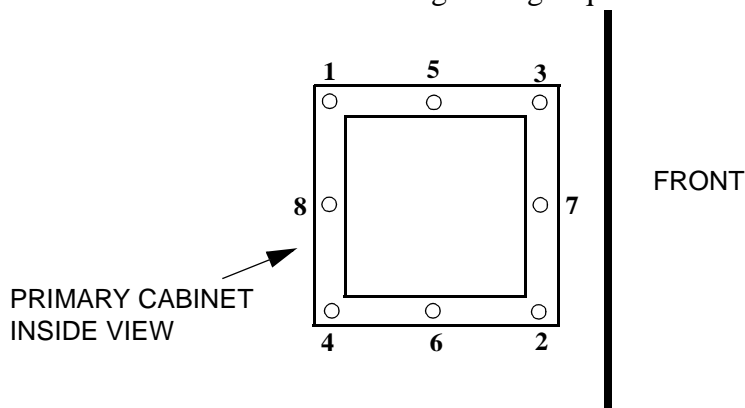

**NOTE:**  
Screws 1 through 8 are inserted from the primary cabinet.

## How to connect the +24-VDC cables in the first WNG24-BC battery cabinet

---

**Important!** +24-VDC cable connections in the first WNG24-BC battery cabinet must be made before any other connections. No DC connections in the Modular Cell 4.0B primary cabinet should be made at this time.

Instructions for the connection of all DC cables in the Modular Cell 4.0B cabinet are included in Chapter 5, immediately after battery installation.

**Important!** Also note, if the primary cabinet should subsequently receive a carrier upgrade that adds the A6 amplifier shelf, the battery compartment is removed. This results in four spare L1 batteries. The end user may wish to use these batteries in the battery cabinet, in which case a shelf must be left vacant. Therefore, while performing any task involving a type 1 top battery shelf (shelf 5), it may be desirable to plan on leaving that shelf empty when installing the batteries in Chapter 5.

**Determine the battery shelf type**

Before proceeding, it is necessary to determine the specific battery shelf, type 1 or type 2, that is installed in the WNG24-BC battery cabinet. The following figures illustrate both battery shelves. Note that type 1 shelves have twenty-four threaded holes in the rear shelf bracket, while the type 2 shelf has none.

- 1 Determine the battery shelf type. The figure below identifies a type 1 shelf

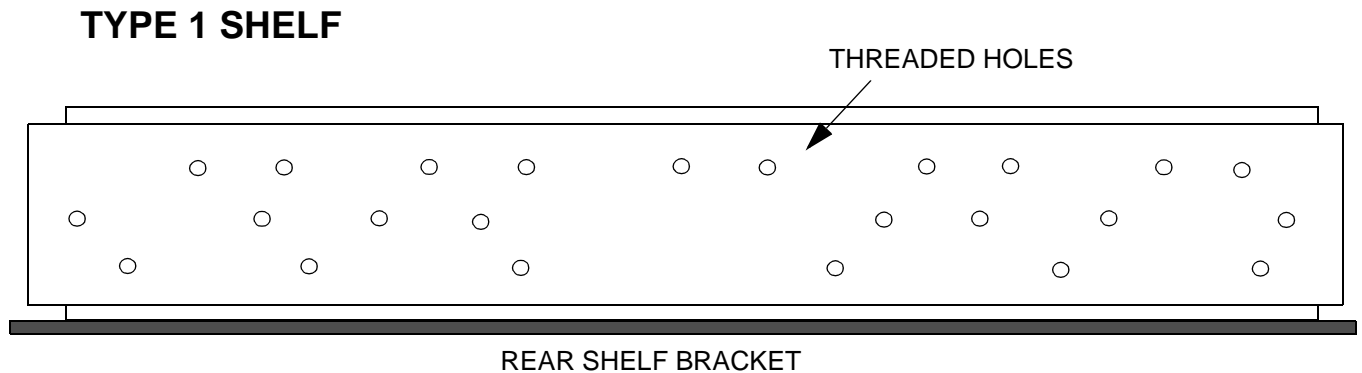

- 2 Determine the battery shelf type. The figure below identifies a type 1 shelf

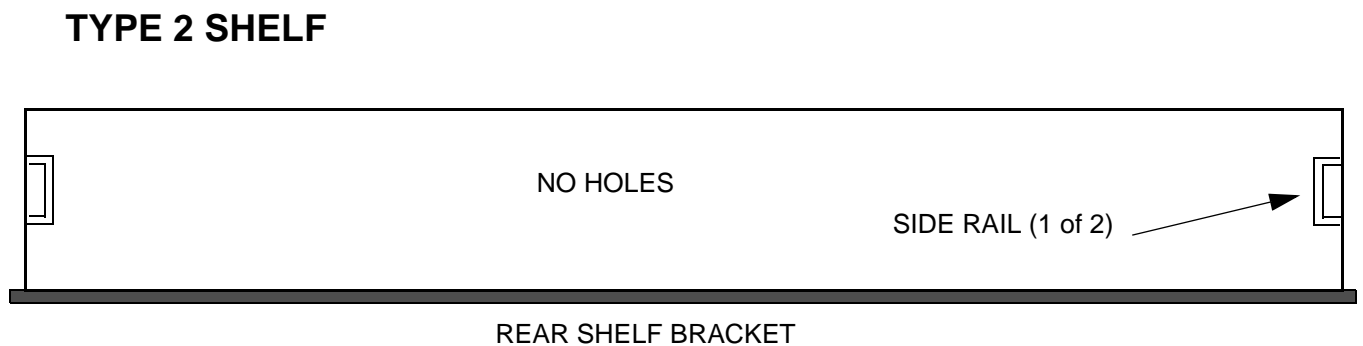

**Connect the DC cables in the first WNG24-BC battery cabinet**

Perform the following steps to connect the +24-VDC and 24-VDC return cables in the first WNG24-BC battery cabinet.

**Important!** Perform the next two steps only if the battery cabinet has type 2 shelves. Otherwise, skip to Step .

- 1 Refer to the figure below and remove the top (shelf 5) battery retaining bracket.
- 2 Refer to the figure below and remove the left-hand side rail from the top shelf (5).

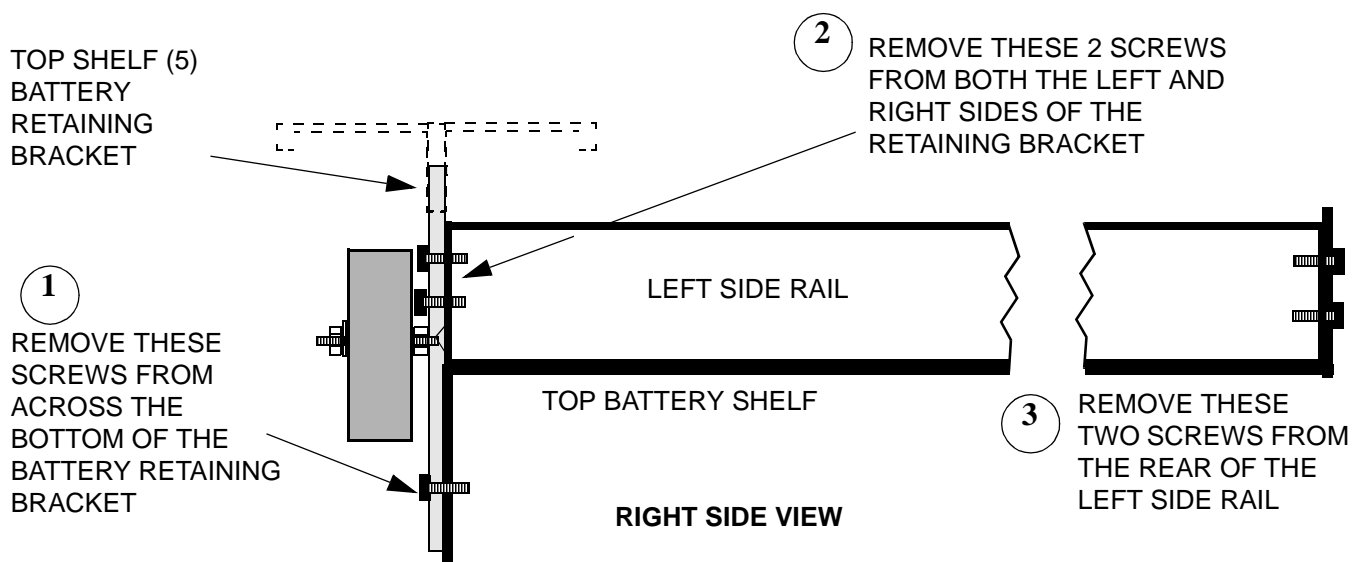
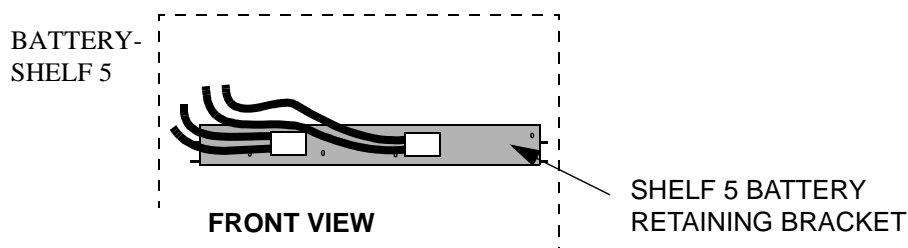



**WARNING**  
**Energy Hazard!**

*When performing the next steps, power should not be applied to the Modular Cell 4.0B primary cabinet. Failure to observe this fact and the safety warnings may lead to bodily injury and property damage.*

- 3 Refer to the figure below, and remove the optional plastic cover from the DC bus bar panel.



PLASTIC COVER

**Important!** When performing the next steps, remove the shrink tubing/tape, one at a time, from the terminal lug being connected.

- 4 Remove the shrink tubing from one of the +24-VDC cables (marked red).
- 5 Connect the +24-VDC cable (marked red) to the +24-VDC (lower) bus bar in the bottom position. Refer to the figure below.
- 6 Repeat the previous two steps, continuing up the positive bus for the remaining three cables, leaving the top two positions blank. Refer to the figure below.

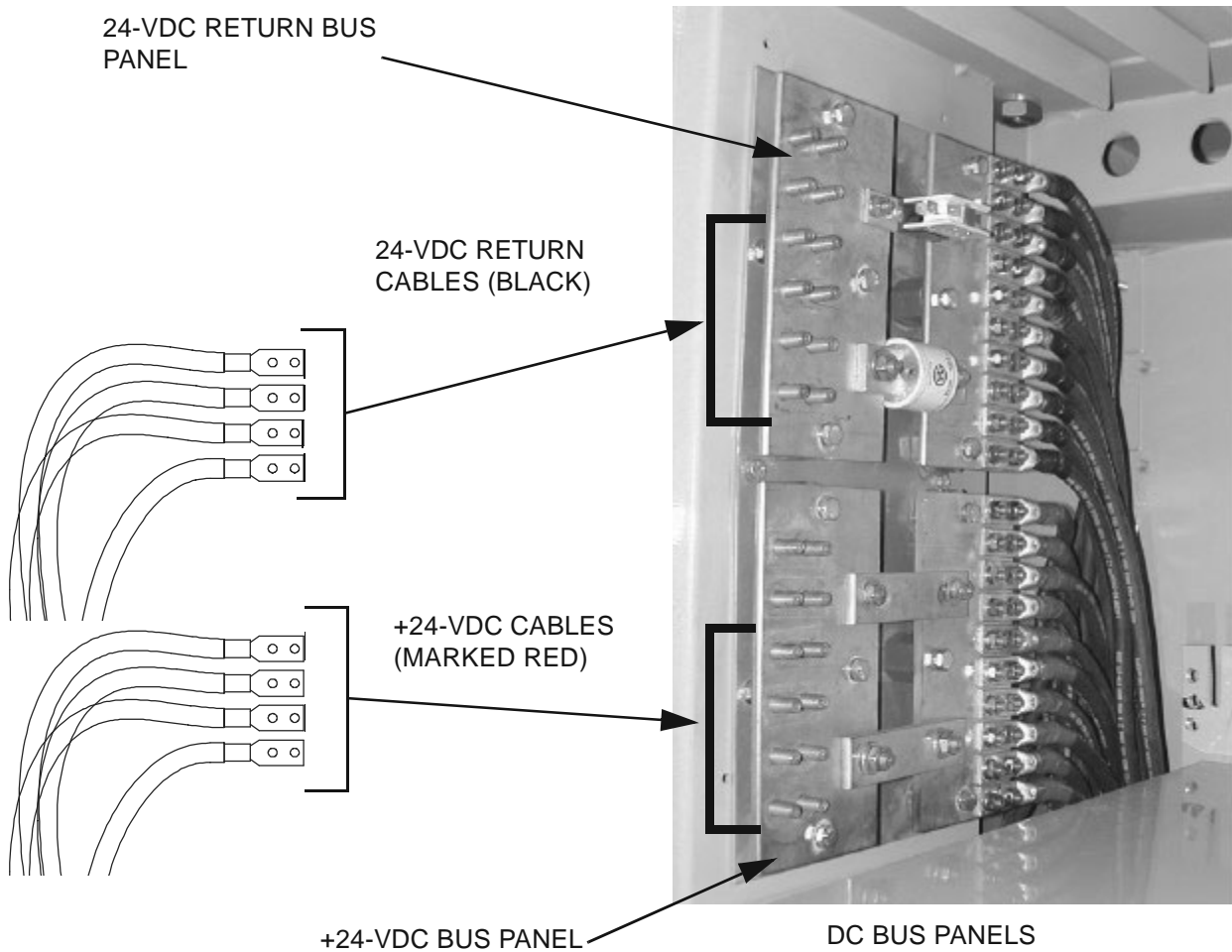



- 
- 7** Remove the tape from the end of one of the four black 24-VDC return cables.
- 
- 8** Connect this 24-VDC return cable starting in the bottom cable position on the return (top) bus. Refer to the figure on Page 4 - 22
- 
- 9** Repeat the previous two steps for the three remaining 24-VDC return cables.
- 
- 10** Torque all 24-VDC cable connections. Refer to the electrical torque specifications provided in Chapter 1.
- 
- 11** As required, dress the 24-VDC cables to the interior left side of the battery cabinet with wire ties.
- 
- 12** Do not replace the plastic cover, the left-hand side rail or the top shelf battery retaining bracket at this time.

END OF STEPS



## How to route and connect the fan power/alarm, fuse alarm, and intrusion alarm cables in the first WNG24-BC battery cabinet

---

**Overview** The remaining cables inside of the battery cabinet, all of which pass through the interface panel, are not yet terminated (the AC cable was shipped already terminated in the WNG24-BC battery cabinet).

**Important!** Thermal probe cables will not be connected until battery installation in Chapter 5.

### Identify the individual interface panel cables on the battery cabinet side

The following is a key to the figure on the next page.

- 
- 1 Identify the following cables/connectors inside of the battery cabinet. Refer to the figure on the next page for cable and connector identification.
    1. The fuse alarm cable
      - a. Connectors SW1 and SW4
      - b. Connector P309 (for fuse alarm cable to second battery cabinet)
    2. The intrusion alarm cable
      - a. Connector P307 (for intrusion alarm cable to second battery cabinet)
      - b. Connectors "C" and "NC" FRONT
      - c. Connectors "C" and "NC" REAR
    3. The fan power/alarm cable
      - a. Connector "FAN" (the fan power/alarm connector)
      - b. P9 (for fan power/alarm cable to second battery cabinet)
      - c. Connector "Tempsw" for the thermostat assembly
      - d. The thermostat assembly (shipped unconnected and is not to be connected and dressed until the routing and connection of the fan power cable)

4. The thermal probe cable
  - a. One thermal probe connection
  - b. One thermal probe; the thermal probe is shipped unconnected and are not to be connected and dressed until after battery installation in Chapter 5

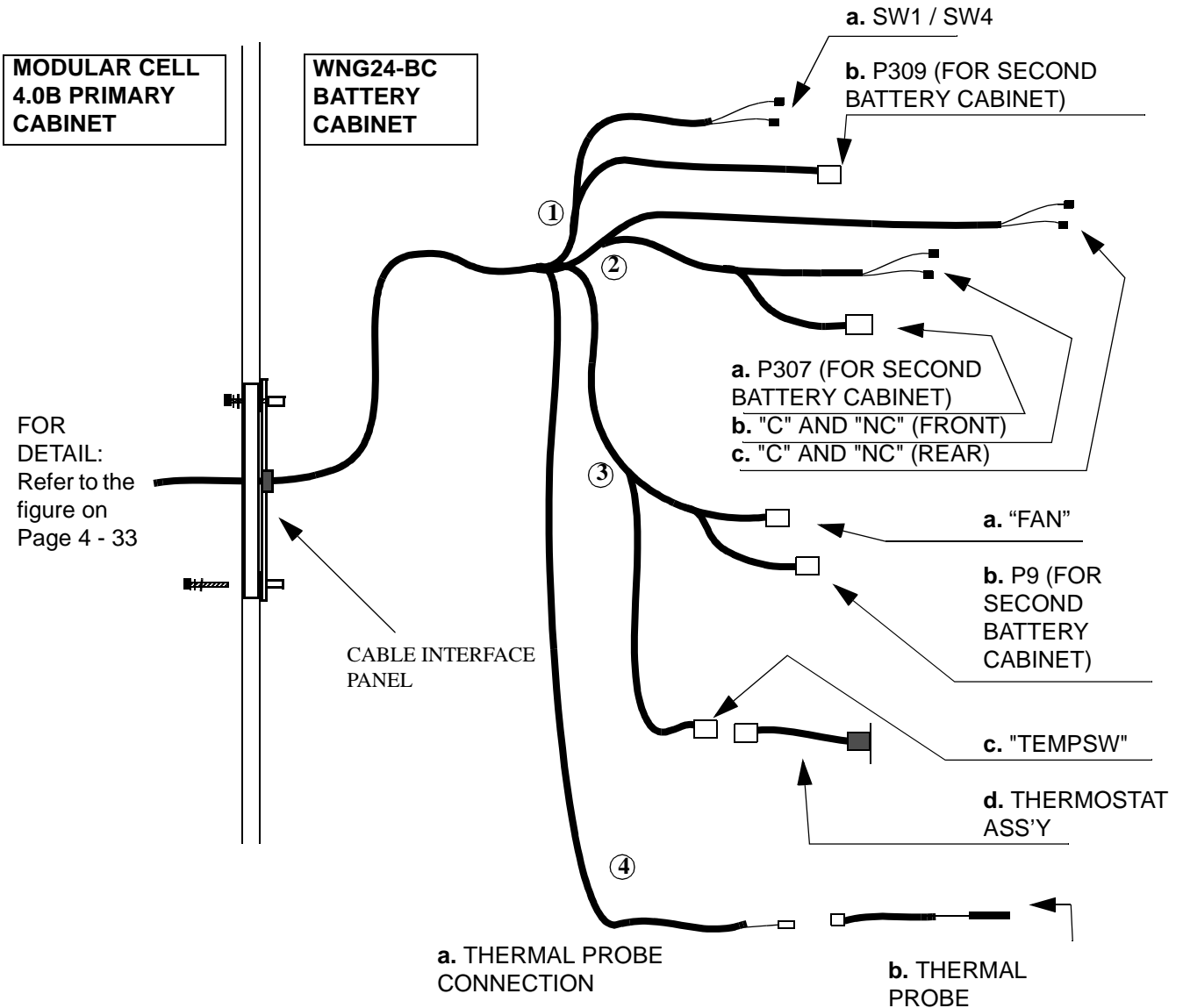

**SIDE VIEW FROM FRONT: DC CABLES NOT SHOWN FOR CLARITY**

**Route and connect the fan power/ alarm cable in the WNG24-BC battery cabinet**

Perform the following steps to route and connect the fan power/ alarm cable in the WNG24-BC battery cabinet.

- 1 Attach the fan power/ alarm cable (labeled "FAN") in the WNG24-BC battery cabinet. Refer to the figure on Page 4 - 27.
- 2 Attach the two pin thermostat connector to the "TEMPSW" connector. Refer to the figure below and the Step 4 figure on Page 4 - 27.



- 3 Dress the thermostat assembly to the fan cable assembly using cable ties. Refer to the figure below.

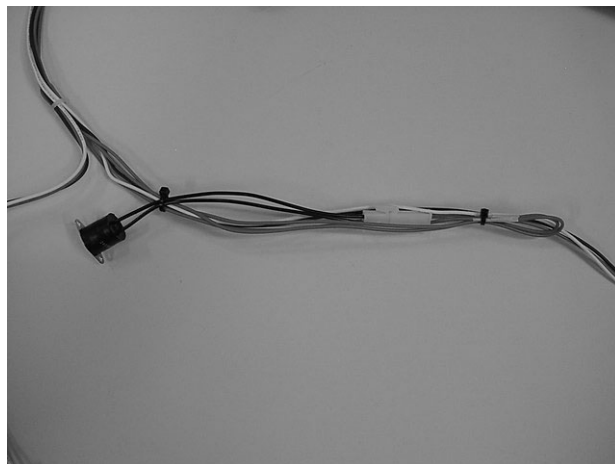

- Using wire ties, dress the fan power/alarm cable and the P9 cable connector (for a future cabinet) to the left interior wall of the battery cabinet. Do this in such a way that they do not interfere with door closure or installation/replacement of parts. Refer to the figure below.

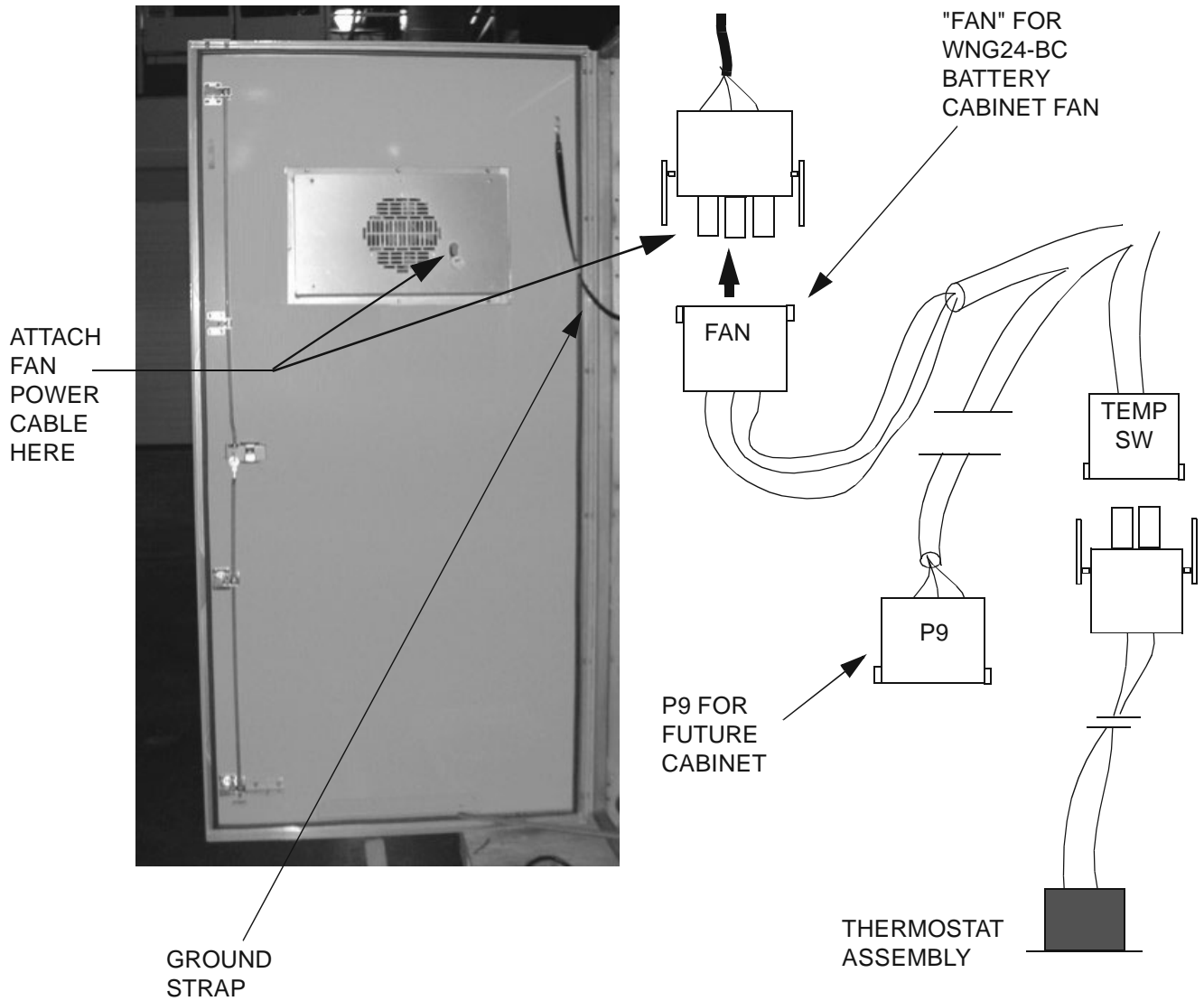

**Route and connect the fuse alarm cable in the WNG24-BC battery cabinet**

Perform the following steps to route and connect the fuse alarm cables in the WNG24-BC battery cabinet.

- 1 Dress the fuse alarm cable that has spade lugs, to the interior left wall of the battery cabinet and secure it with wire ties. Refer to the figure below.
- 2 Route the P309 cable and connector across the interior top of the cabinet to the square opening for a future cabinet (on the right side of the cabinet), as shown in the figure below.
- 3 Using wire ties, secure the P309 fuse alarm cable to the interior top of the battery cabinet at the "U" channel, and at the tie point locations shown in the figure below.

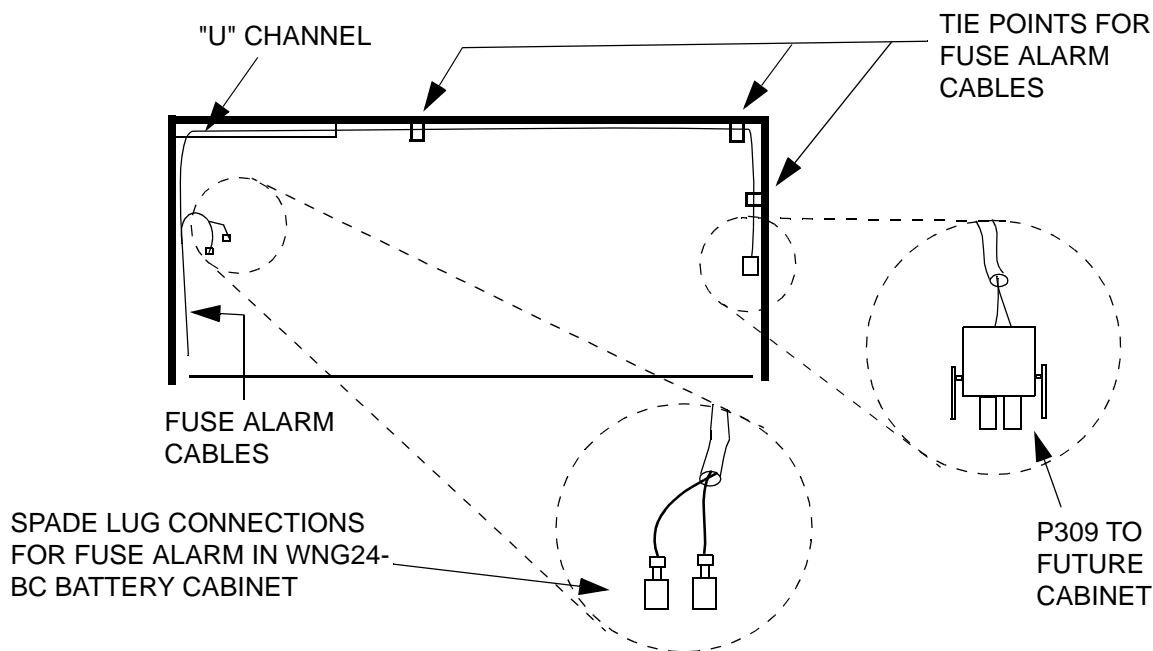

- 
- 4 Refer to the figure below and connect the fuse alarm cable as shown.

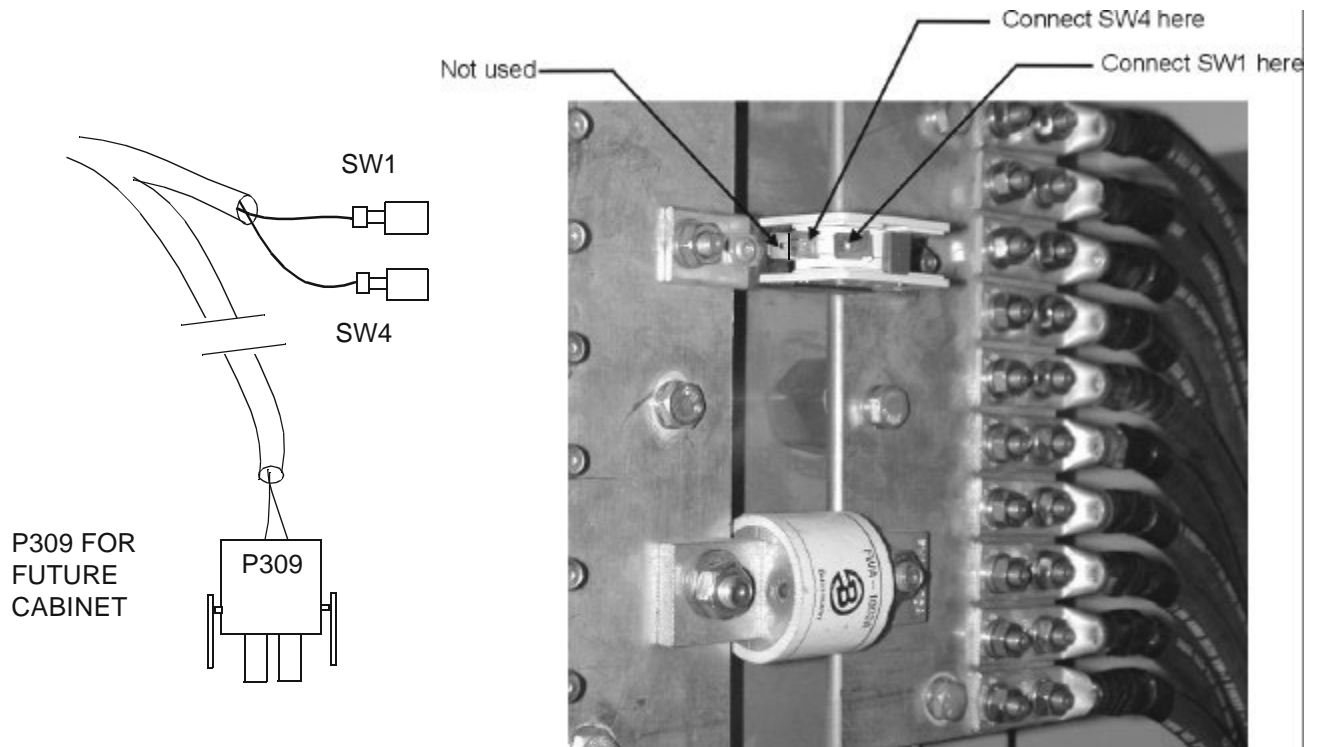

- 
- 5 Replace the plastic cover on the DC bus bar panel.

**Important!** If the battery cabinet has type 1 battery shelves, skip the next step.

- 
- 6 Replace the left-hand side rail on the top battery shelf. Do not reinstall the top shelf battery retaining bracket at this time, unless the top shelf will not be populated with batteries. Refer to the figure on Page 4 - 20.

END OF STEPS

---

**Route and connect the intrusion alarm cables in the WNG24-BC battery cabinet**

Perform the following steps to route and connect the intrusion alarm cables in the WNG24-BC battery cabinet.

- 1 Route the intrusion alarm cables across the interior top of the cabinet to the square opening for a future cabinet (on the right side of the cabinet), as shown in the figure below. Secure the cables to the interior top of the battery cabinet with wire ties at the "U" channel, and at the tie point locations shown.

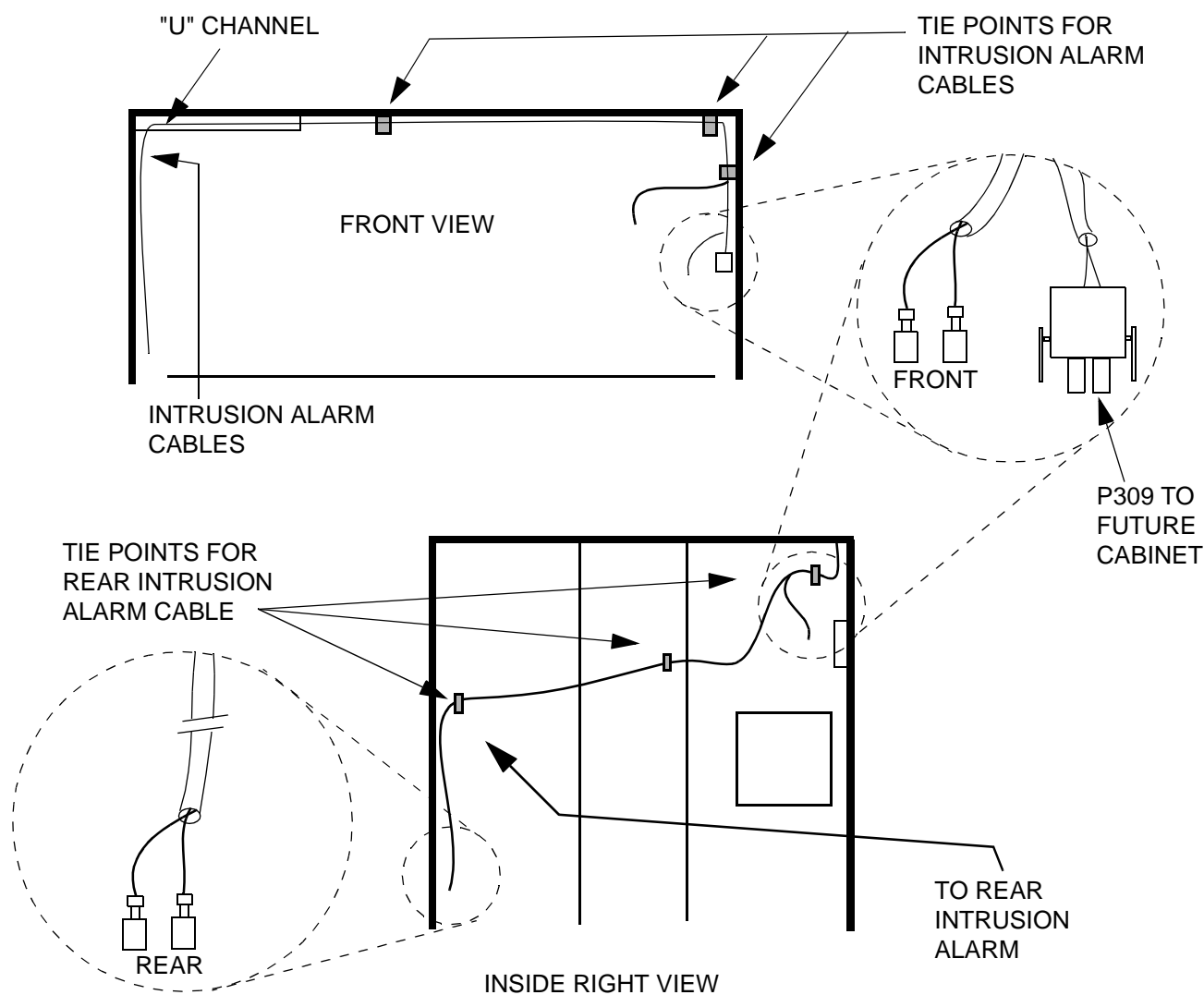



- 2 Refer to the figure below and connect the front intrusion cable as shown.

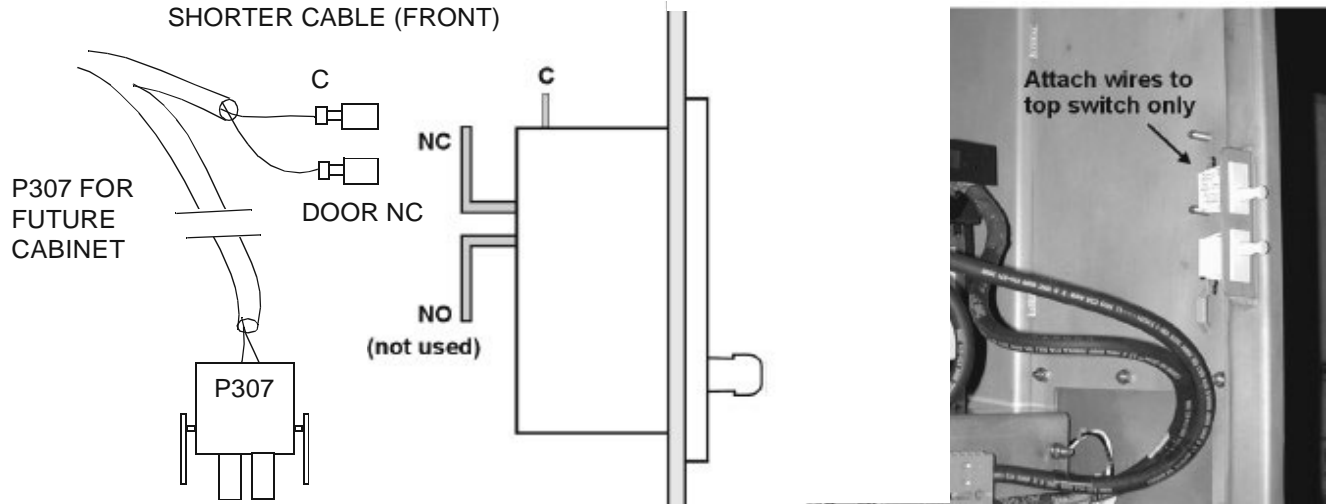

- 3 Route and secure the rear intrusion cable to the interior right side of the battery cabinet with wire ties at the tie point locations. Refer to the figure on Page 4 - 30.

- 4 Refer to the figure below and connect the rear intrusion cable as shown.

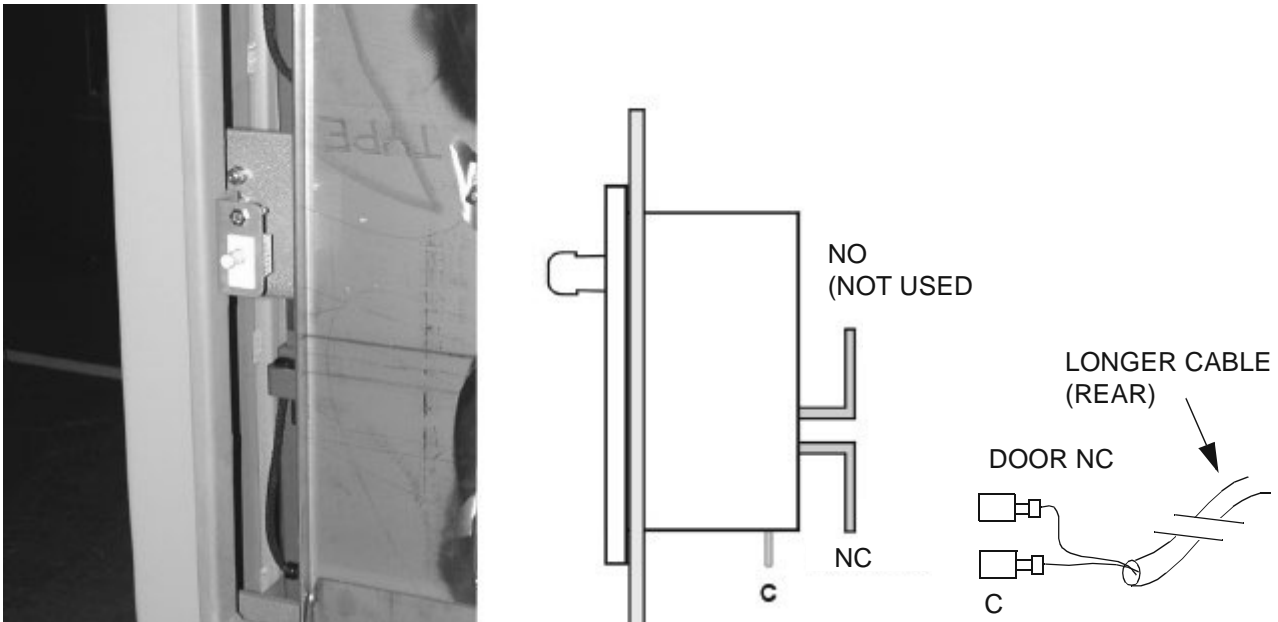

## How to connect the alarm, thermal probe and fan power/alarm cables in the Modular Cell 4.0B primary cabinet

---

**Important!** DC connections in the Modular Cell 4.0B cabinet must not be made at this time. Instructions for the connection of the DC cables in the Modular Cell 4.0B cabinet are included in Chapter 5, after battery installation.

**Identify the individual interface panel cables on the primary cabinet side**

The following is a key to the figure on the next page.

- 1 Identify the following cables/connectors inside of the primary cabinet. Refer to the figure below for cable identification.

1. Four DC cables (terminal lugs taped; not to be connected until after battery installation in Chapter 5)
2. The fuse alarm cable (J309)
3. The battery cabinet fan power/alarm cable (J9)
4. The intrusion alarm cable (J307)
5. The intrusion alarm adapter cable (supplied with kit). Refer to the figure on Page 4 - 38
6. The thermal probe cable

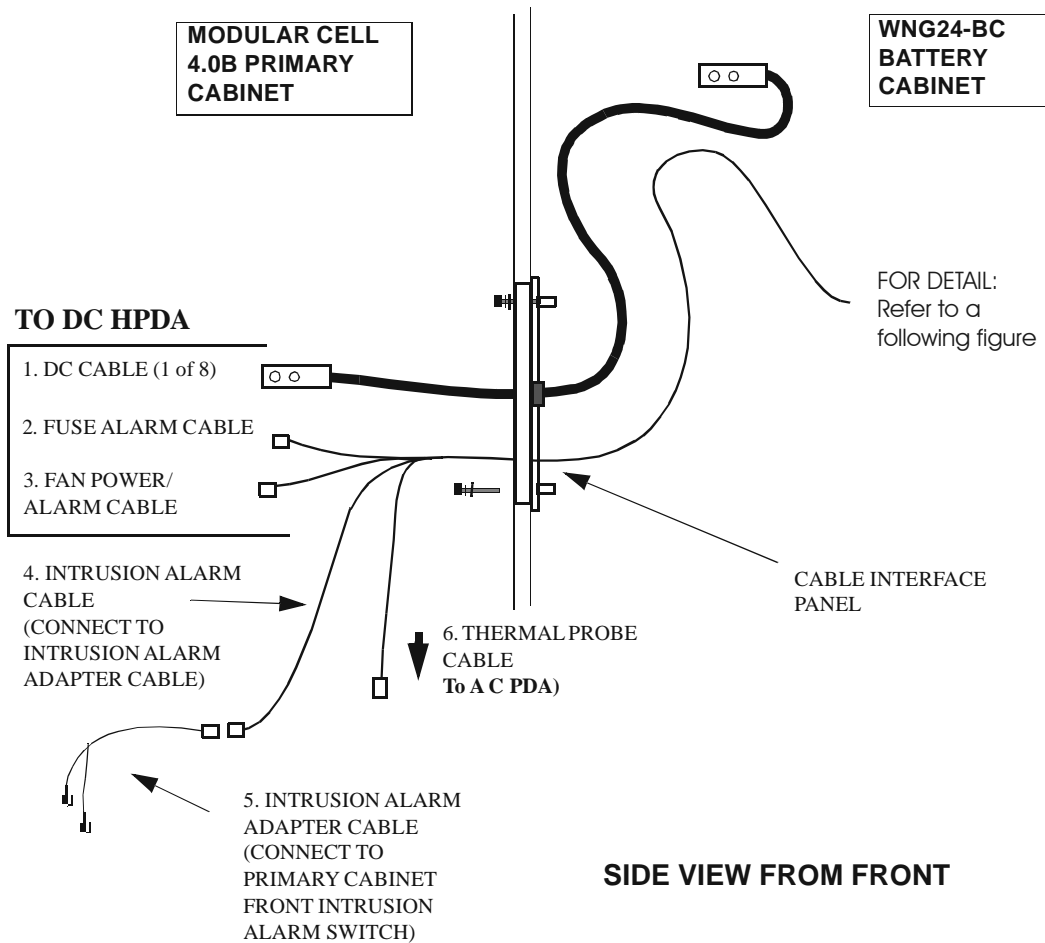

**Connect the fuse alarm and fan power/alarm cables in the Modular Cell 4.0B primary cabinet**

Perform the following steps to connect the fuse alarm and fan power/alarm cables in the Modular Cell 4.0B primary cabinet. Refer to the figure on Page 4 - 33 for cable identification.

- 1 Loosen the thumb screws and open the door of the HPDA (High Power Distribution Assembly).
- 2 Connect the fan power/alarm cable connector (J9 from the battery cabinet) to the connector on the circuit board that is mounted on the inside of the HPDA door in the Modular Cell 4.0B primary cabinet. Refer to the figure below for the connector location on the HPDA.

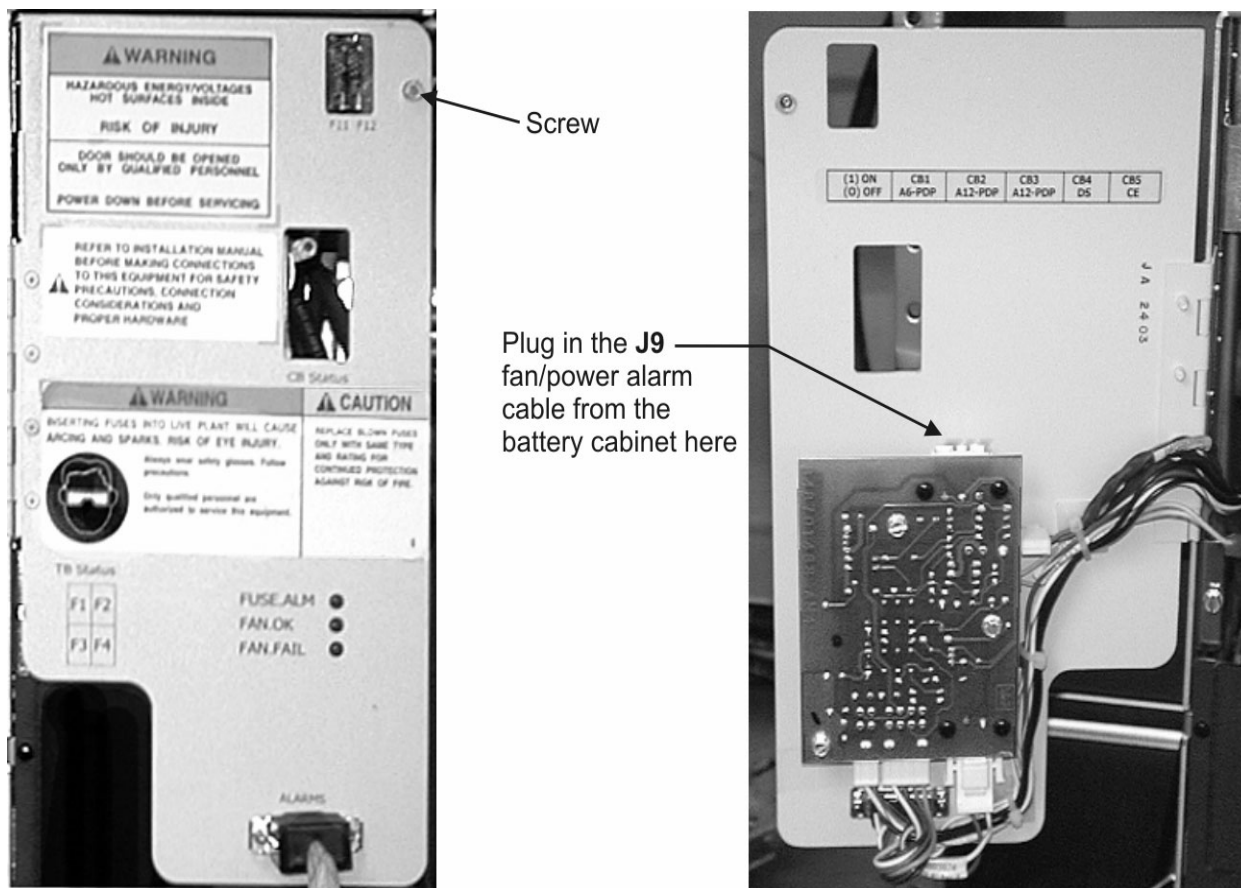

- 
- 3** Connect the fuse alarm cable connector (J309 from the battery cabinet) to the fuse alarm cable connector located to the right of the HPDA in the Modular Cell 4.0B primary cabinet. Refer to the figure below for the connector location.

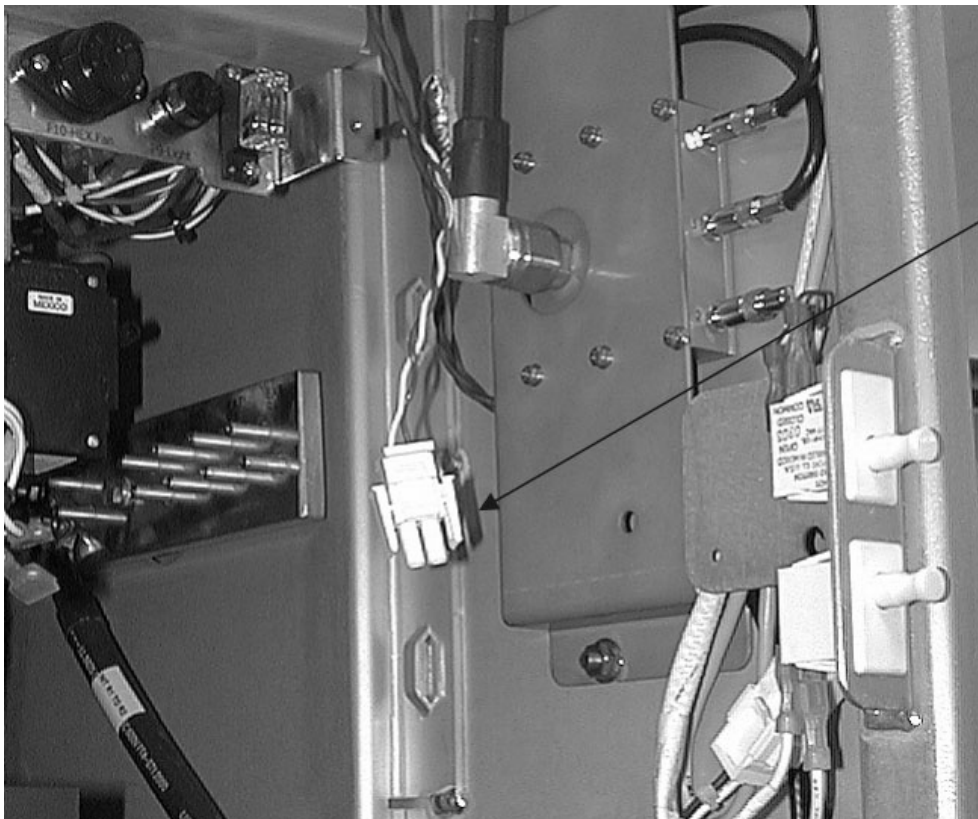

- 
- 4** Using wire ties, dress the cables to the interior right side of the primary cabinet. Do this in such a way that they do not interfere with HPDA door opening and closure, or installation/replacement of parts.

END OF STEPS

---

**Connect the intrusion alarm cable in the Modular Cell 4.0B primary cabinet**

Refer to the figure below and perform the following steps to connect the intrusion alarm cable in the Modular Cell 4.0B primary cabinet.

- 1 Disconnect the cable attached to the front intrusion alarm switch (two spade lugs, C and NC). Refer to the figure below.

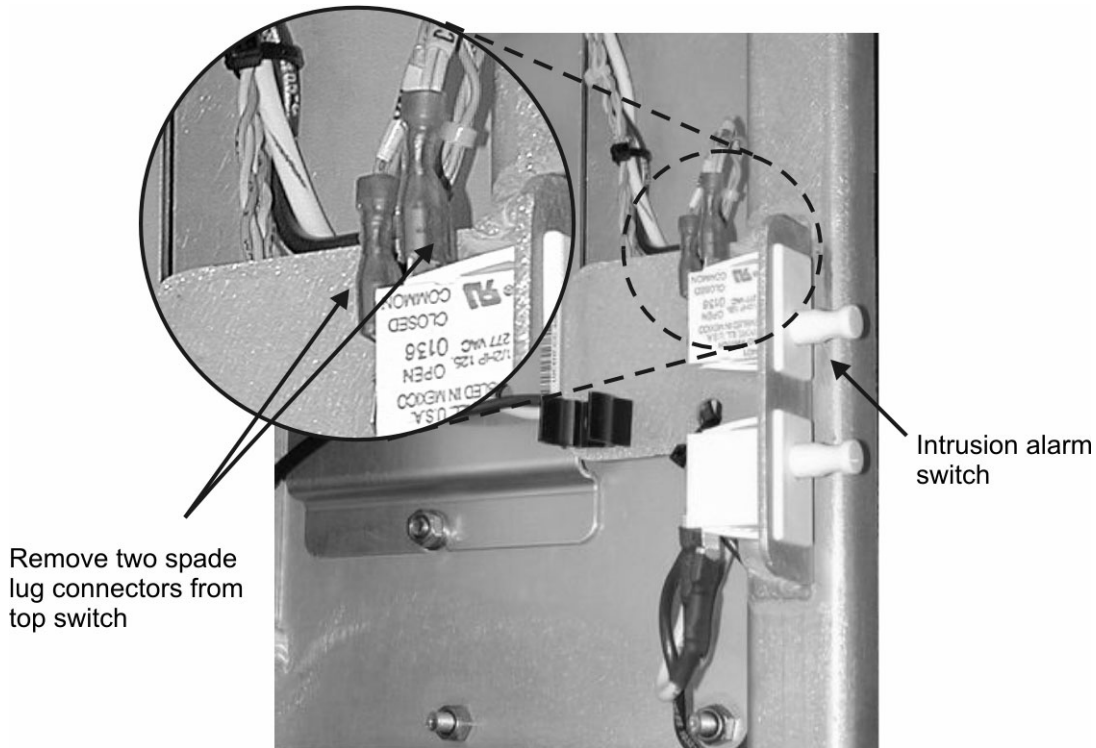

- 2 Locate and attach the separately supplied adapter cable, connector P307, to the J307 connector of the intrusion alarm cable coming from the battery cabinet. Refer to the figure on Page 4 - 37, item 1.
- 3 Attach double spade lugs on the end of the adapter cable, to the front intrusion alarm switch NC and C connections. Refer to the figure on Page 4 - 37, item 2.

- 4 Attach the spade lug connectors of the cable disconnected in Step 1, to the adapter cable double spade lug NC and C connections on the intrusion switch, where they were connected in the previous step. Refer to the figure below, item 3.
- 5 Using wire ties, dress the intrusion alarm cables to the interior right side of the primary cabinet. Do this in such a way that they do not interfere with HPDA door opening and closure, or installation/replacement of parts.

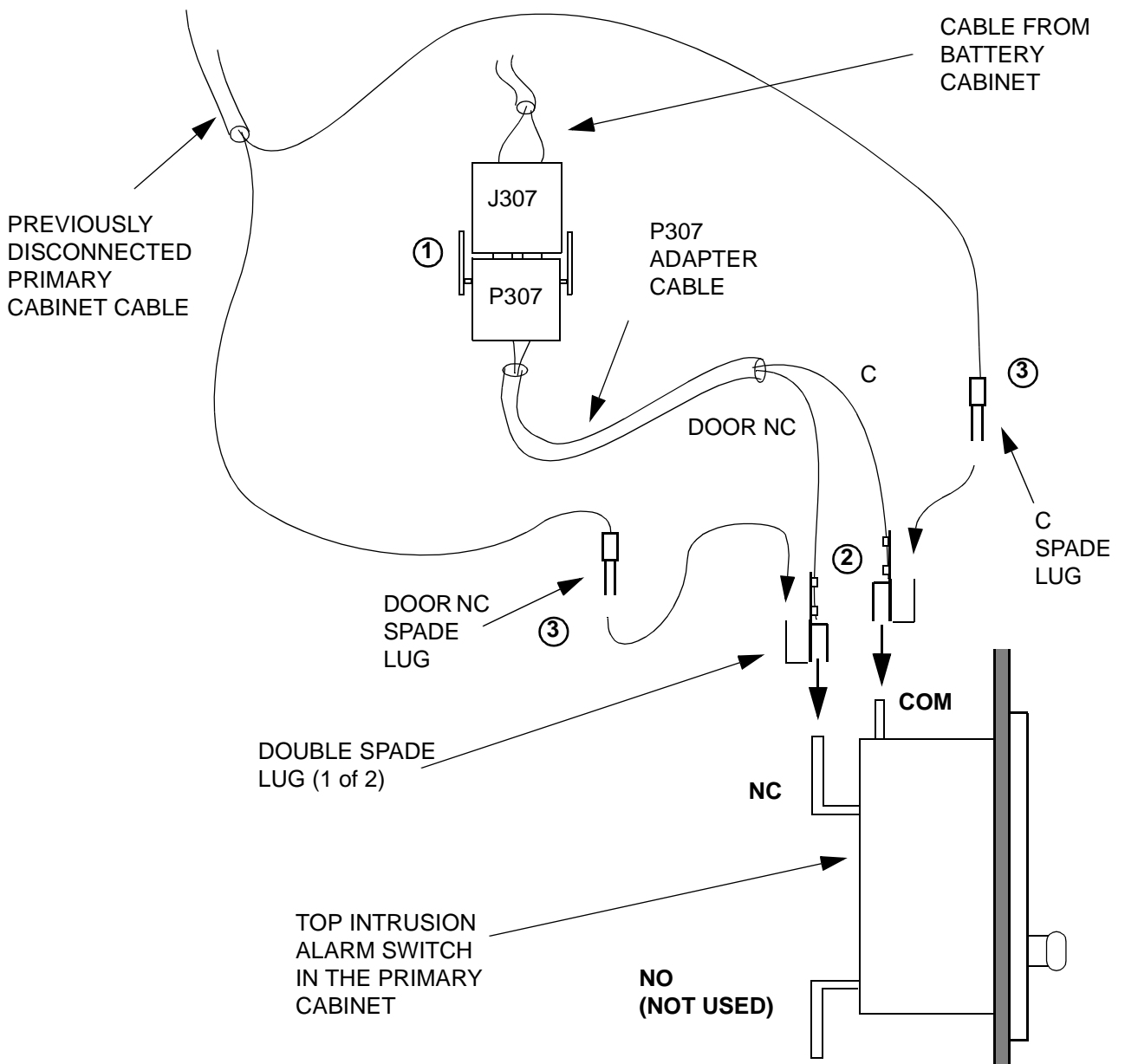

**Route and connect the thermal probe cable in the Modular Cell 4.0B primary cabinet**

Perform the following steps to route and connect the thermal probe cable in the Modular Cell 4.0B primary cabinet.

- 1 Route the thermal probe cable down to the AC PDA. Refer to the figure below. Connect the thermal probe cable to the 3-pin connector P1 to P4 (P1-BATT) as shown below.

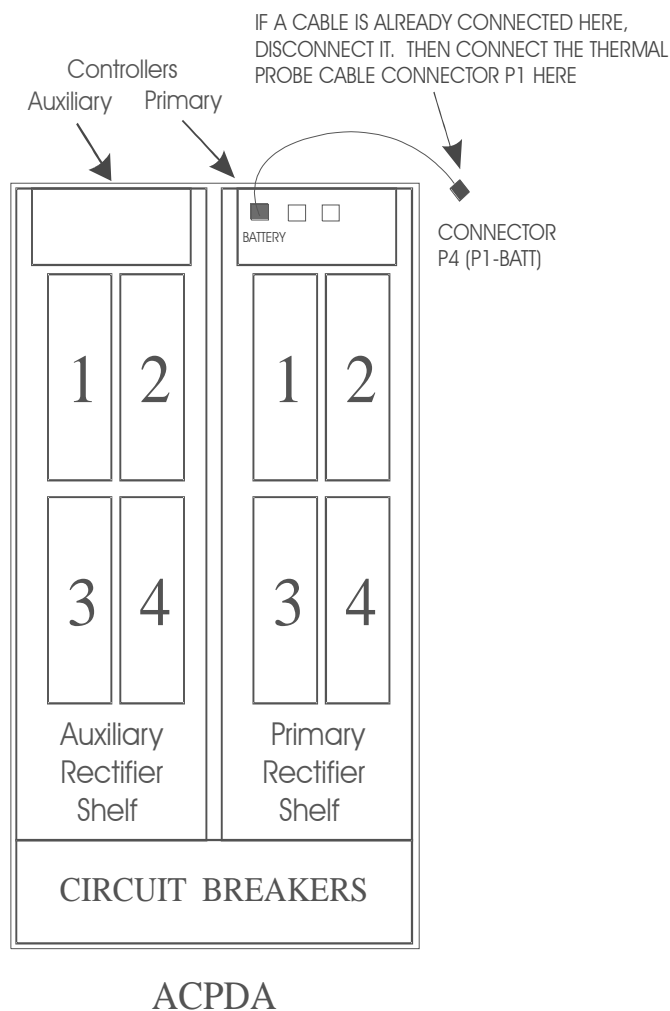

- 2 Using wire ties, dress the thermal probe cables with wire ties, to the interior right side of the primary cabinet. Do this in such a way that they do not interfere with HPDA door opening and closure, or installation/replacement of parts.



## How to route and connect the battery cabinet AC power cable in the Modular Cell primary cabinet

---



### **DANGER**

#### Electrical Shock Hazard

*Failure to follow the order of the installation procedure (as written) can result in an energized AC or DC circuit, which creates an electrical shock hazard.*

*Follow these rules:*

- 1. Perform installation steps in the order provided. Do not connect AC power until instructed to do so.*
- 2. Do not connect battery connectors.*
- 3. Observe and strictly follow all safety precautions.*
- 4. When completing electrical connections, always use tools that are properly insulated.*

**Route the AC power cable into the Modular Cell 4.0B primary cabinet**

Perform the following steps to route the AC power cable into the Modular Cell 4.0B primary cabinet.

- 1 The AC power cable is shipped already terminated at the AC junction box in the WNG24-BC battery cabinet. Refer to the figure below.

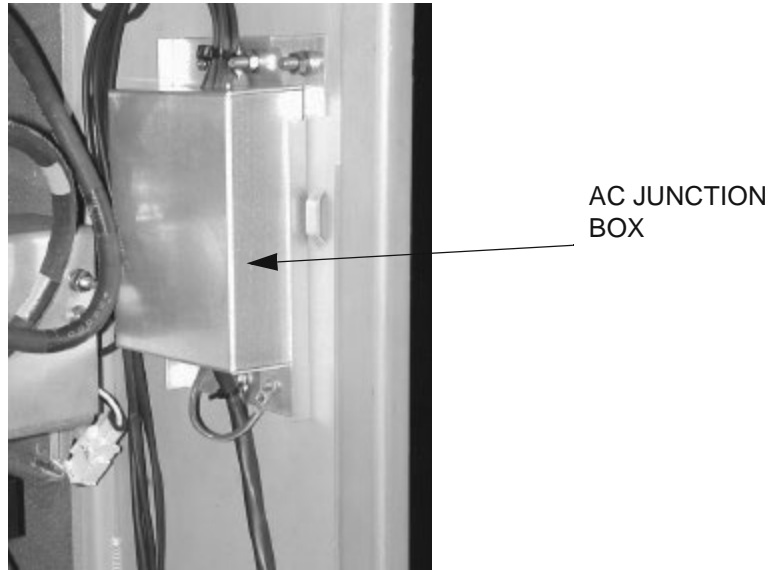

- 2 The AC power cable is shipped coiled in the bottom of the battery cabinet. Remove the AC power cable from the bottom of the cabinet and uncoil. Refer to the figure below.



- 3 Thread the AC power cable through the seal on the end of the coupling reducer, and through the AC coupling into the Modular Cell 4.0B primary cabinet and tighten the seal. Refer to the figure below.

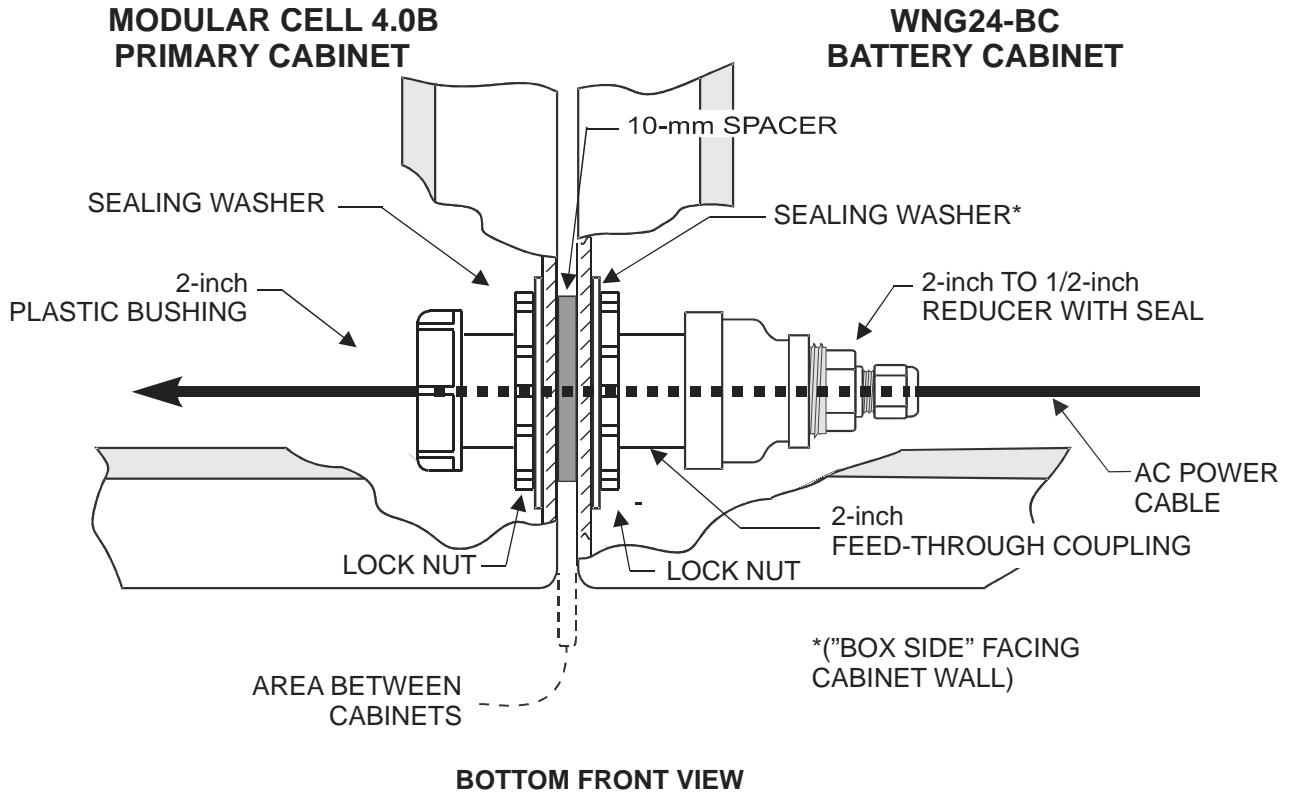

**Connect AC cable in the Modular Cell 4.0B primary cabinet**

Perform the following steps to connect the WNG24-BC battery cabinet AC cable in the Modular Cell 4.0B primary cabinet.

- 1 In the Modular Cell 4.0B primary cabinet, place the circuit breaker "BATTERY HEATER" to the off position. Refer to the figure below.
- 2 Locate the three-pin connector (P6) at the bottom left of the AC PDA. Refer to the figure below.

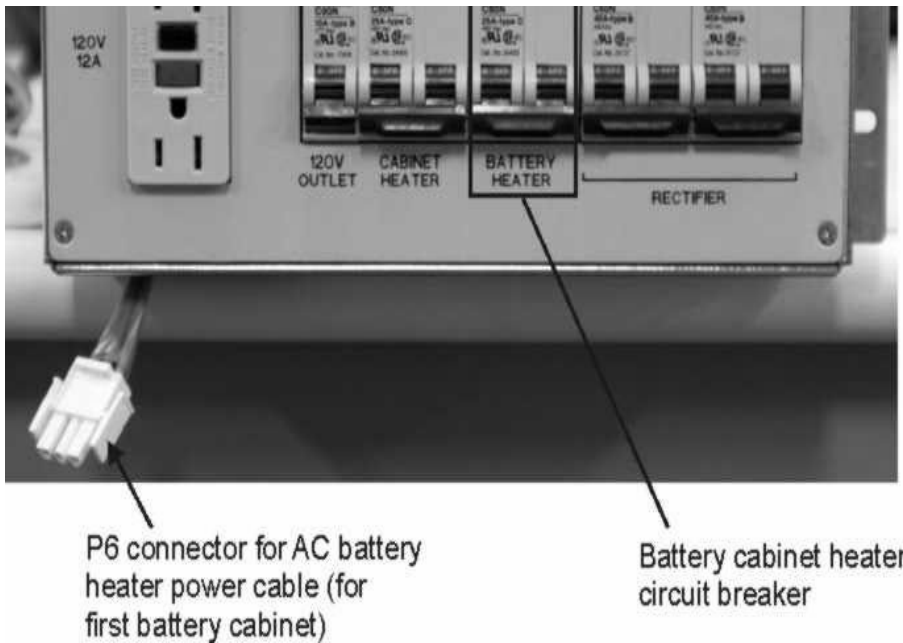

- 3 Cut the AC cable (from the battery cabinet) to the desired length.
- 4 Remove the outer cable insulation to expose the individual wires, and strip 15 mm (3/8 inch) of insulation from each wire.
- 5 Slide a section of heat shrink tubing over the AC cable.

- 6 Using the solderless connectors supplied with the adapter cable kit, crimp the wires of the AC cable to the adapter cable as follows. Refer to the table and figure below.

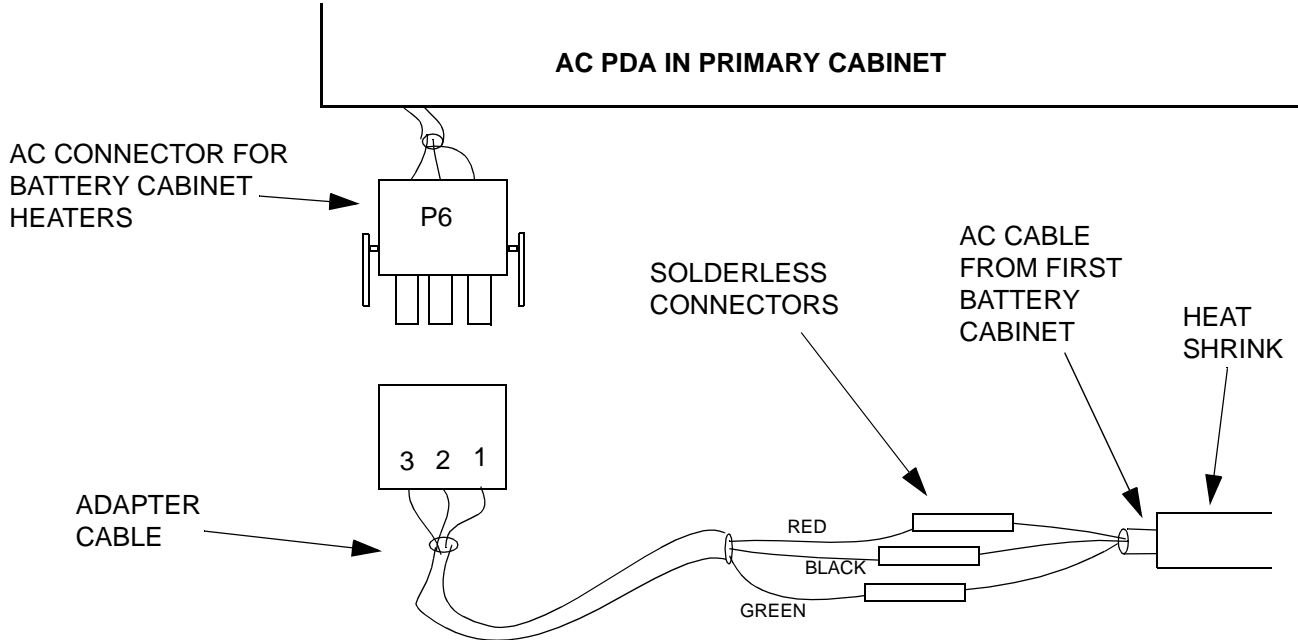

Adapter Cable Pin Number	Adapter Cable Label	Adapter Cable Color Code	Battery Cabinet Cable Label
1	L1	RED	L1 / RED
2	L2	BLACK	L2 / BLACK
3	GND	GREEN	GND / GREEN

- 7 Position the heat shrink tubing over the solderless connectors, and shrink with a heat gun.
- 8 Attach the three-pin connector to the connector shown in the figure on Page 4 - 42.
- 9 Using wire ties, dress the AC cable in both cabinets so that it will not interfere with door closure or installation/replacement of parts.
- 10 Proceed to Chapter 5 if not installing a second battery cabinet.

# How to make the cable connections between the second WNG battery cabinet and the first WNG battery cabinet

## Overview

---

**Purpose** This section contains the following procedures.

<u>How to disconnect DC power</u>	4 - 45
<u>How to route and connect the DC cables between the first and second WNG24-BC battery cabinets</u>	4 - 48
<u>How to route and connect the alarm and fan power/alarm cables in the second WNG24-BC battery cabinet</u>	4 - 54
<u>How to route and connect the alarm and fan power/alarm cables in the first WNG24-BC battery cabinet</u>	4 - 62
<u>How to route and connect the AC power cable in the first battery cabinet</u>	4 - 66

## How to disconnect DC power

---

**Overview** The purpose of this section is to provide the installer with instructions for the following tasks. These tasks are required to prevent electrical shock hazards while installing the second battery cabinet.

**Disconnect all battery connectors in the first battery cabinet**



**WARNING**  
**Energy Hazard!**

*When performing the following procedures, power should not be applied to the Modular Cell 4.0B primary cabinet.*

Before the installation of the second battery cabinet can begin, the following steps must be performed to disconnect the battery connectors on the battery retaining brackets in the first battery cabinet. This is done in order to prevent the possibility of electrical shock while installing the cabinet.

- 
- 1** At the battery retaining brackets in the first battery cabinet, disconnect the two battery connectors on the bottom shelf. Refer to the figure on Page 4 - 46.

- At the battery retaining brackets in the first battery cabinet, disconnect the battery connectors on all remaining populated shelves.

