

## Exhibit 11 Listing of Required Measurements

### SECTION 2.1033(c)(14)

The data required by Section 2.1046 through 2.1057, inclusive, measured in accordance with the procedures set out in Section 2.1041.

Response:

The lowest clock frequency in the **FLEXENT® OneBTS® PCS CDMA Modular Cell 4.0 with EDPD** is the 10 MHz rubidium reference oscillator. Conducted spurious measurements were performed over the range of 10 MHz to 20 GHz which is above the tenth harmonic of the transmit frequency range.

The following pages include the data required for the Product Certification authorization of the **PCS UMTS-CDMA EDPD Transceiver System / FCC ID: AS5ONEBTS-10**, measured in accordance with the procedures set out in Section 2.1041 of the Rules.

Each required measurement and its corresponding exhibit number are:

Exhibit 12	Section 2.1046	Measurement of Radio Frequency Power Output
Exhibit 13	Section 2.1047	Measurement of Modulation Characteristics
Exhibit 14	Section 2.1049	Measurement of Occupied Bandwidth
Exhibit 15	Section 2.1051	Measurement of Spurious Emissions at Antenna
Exhibit 16	Section 2.1053	Field Strength of Spurious Radiation
Exhibit 17	Section 2.1055	Measurement of Frequency Stability

## Exhibit 12 MEASUREMENT OF RADIO FREQUENCY POWER OUTPUT

### SECTION 2.1046 Measurements required: RF power output.

The test arrangements used to measure the radio frequency power output of the **PCS UMTS-CDMA EDPD Transceiver/ AS5ONEBTS-10** is on the following page. Measurements were made respectively at each frequency where Occupied Bandwidth measurements were performed. This Class II Change is for use of the **PCS UMTS-CDMA EDPD Transceiver** with 3 P2PAM's for seven and eight CDMA carriers. The multi-carrier operation in the 5 MHz wide PCS D, E, F and G Block, is presently authorized and limited to a maximum of three carriers at 20 watts/carrier. Demonstration of compliance with the lower power operation seven and eight carrier configuration was demonstrated across the PCS band for deaggregation application purposes and specifically for PCS Blocks A, B and C. There is no retuning or change in hardware necessary for operation in any PCS Block. This testing requires that the J4 power level be calibrated for the specific channel of use. The test configuration, Figure 12a, allowed the measurement of output power for each channel investigated for Occupied Bandwidth. These included the upper and lower Block edges and at the center channel for each Block.

In this seven and eight carrier via 3 P2PAM configuration, the **PCS UMTS-CDMA EDPD Transceiver** system has a maximum power output of 120 Watts at the antenna terminals (42.34 dBm/c for seven carriers and 41.76 dBm/c for eight carrier) +2/-4 dB for each carrier in these applications. It also has a minimum power output at the antenna terminals of 0.0171 Watts/c for seven carriers 0.0150 Watts/c for eight carriers (12.34 dBm / 11.76 dBm respectively +2 / -4 dB), across the PCS downlink Band (1930.00-1995.00 MHz). The signal applied to the **PCS UMTS-CDMA EDPD Transceiver** is defined in Table 12.1. The power was reset to the specified 120 W maximum at each measurement frequency to verify the spectral performance at that power level at each specific frequency of interest. The attenuation range was also verified. The specific Frequencies and channels and set power level was documented on each "Occupied Bandwidth" sheet.

The applied signal, from a **PCS UMTS-CDMA EDPD Transceiver/ AS5ONEBTS-10**, met the recommended characteristics per "**Table 6.5.2-1 Base Station Test Model, Nominal**" from **3GPP2 TSG-C.S0010-C-v1.00, February 2005**, Recommended Minimum Performance Standards for cdma2000 Spread Spectrum Base Stations, as defined below in table 12.1.

**Exhibit 12** *continued*

Type	Number of Channels	Fraction of Power (Linear)	Fraction of Power (dB)	Comments
Pilot	1	0.2	-7	Code channel $W_0^{128}$
Sync	1	0.0471	-13.3	Code channel $W_{32}^{64}$ ; always 1/8 rate
Paging	1	0.1882	-7.3	Code channel $W_1^{64}$ ; full rate only
Traffic	6	0.09412	-10.3	Variable code channel assignments; full rate only

**TABLE 12.1 Base Station Test Model, Nominal for Main Path**

Type	Number of Channels	Fraction of Power (Linear)	Fraction of Power (dB)	Comments
Transmit Diversity Pilot	1	0.2	-7	Code channel $W_{16}^{128}$
Traffic	6	0.09412	-10.3	Variable code channel assignments; full rate only

**TABLE 12.2 Base Station Test Model, Nominal for Transmit Diversity Path**

### Exhibit 12 RF Power Test Configuration

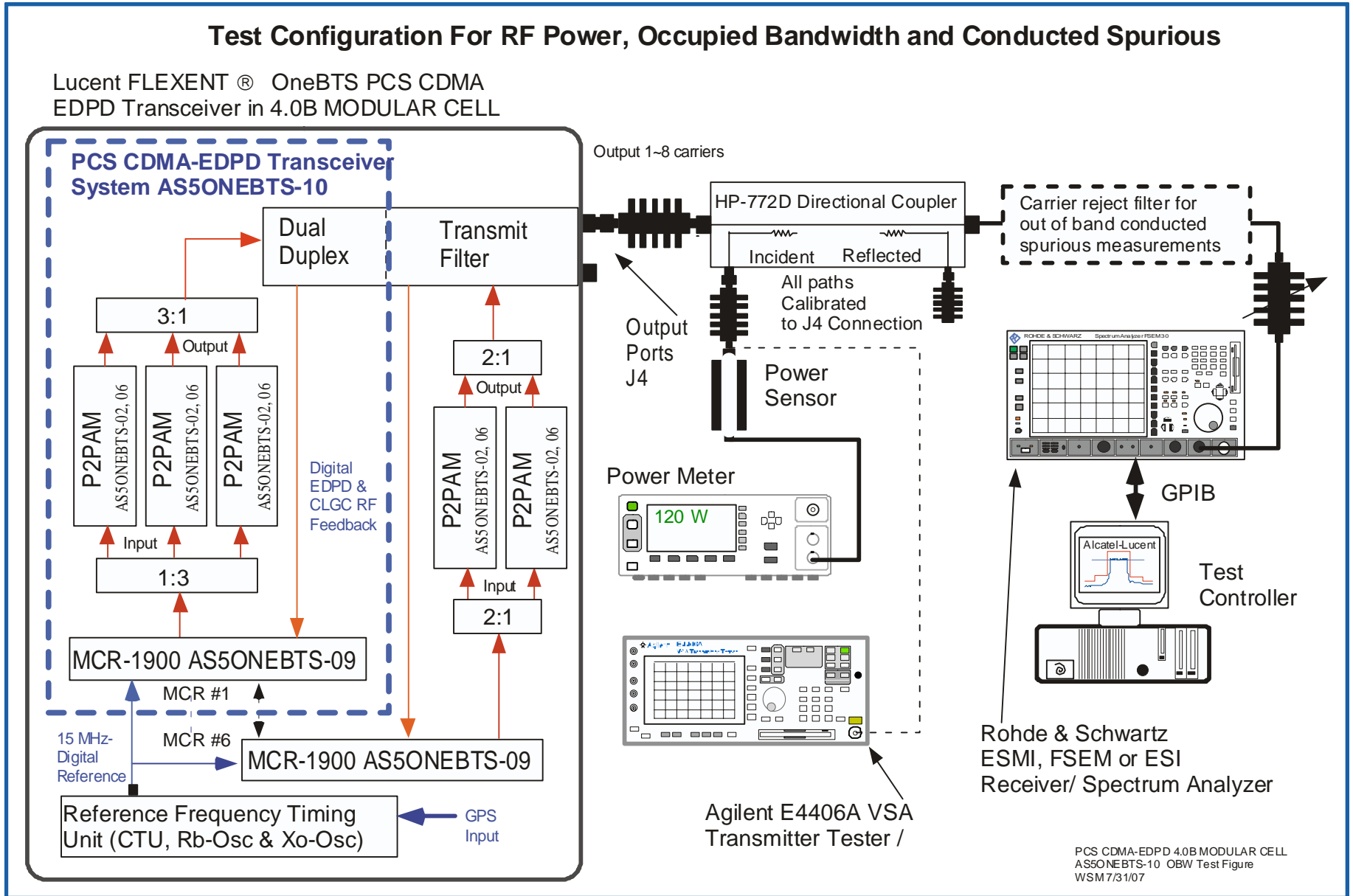

**Exhibit 12** *continued*

**Equipment used for RF Power, Modulation, Occupied bandwidth, Conducted Spurious and Radiated Spurious Measurements**

<u>Equipment</u>	<u>Description</u>	<u>Calibration Reference Number</u>	<u>Version date or Calibration</u>
<b>Power Meter:</b>	Agilent N1912A P Series Power Meter	82-11293400	27 Oct 07 due
<b>Power Head</b>	Agilent N1921A 0.05-18 GHz Wideband Power Sensor	82-11293379	21 Jun 08 due
<b>Spectrum Analyzer:</b>	Rohde & Schwarz FSEM-30	167437	11 Apr 07
<b>EMC Receiver</b>	Rohde & Schwarz ESIB-40	100101	17 Nov 07 due
<b>Code Domain Analyzer</b>	Agilent E4406 VSA Transmitter Tester	169441 UR	06 Sep 07 due
<b>Computer Controller:</b>	EG Technology, Intel Pentium PC w/ WIN 2000 OS	POR-2,4 & 6	N/A
<b>EMC Test Software</b>	TILE, Quantum Change,	Version 3.4.K.14	22 Aug 06
<b>Printer:</b>	HP Model 4500DN Printer	N/A	N/A
<b>Low Pass Filters:</b>	10 MHz-1.93 GHz, Custom manufactured	PCSLPF-11	04 Aug 06
<b>High Pass Filters:</b>	1.99-20 GHz, Custom manufactured	PCSHPF-11	04 Aug 06
<b>Test Cables:</b>	Low loss test cables custom mfg.	Chamber-1 set	04 Aug 06
<b>Antenna</b>	BiConiLog Antenna, ETS, Model 3142B	1770	27 Mar 08-due
<b>Antenna</b>	Double Ridge guide Antenna, ETS, Model 3115	3115-6685	16 Mar 08-due
<b>Preamplifier</b>	Amplifier Low Noise, Miteq, 1.7 dB	LNA-1	04 Sep 07
<b>GPS Receiver</b>	Symmetricom 58503B (former Agilent)	KR93200849	N/A
<b><u>RF Test coupler</u></b>	<b><u>The equipment below is maintained and calibrated together.</u></b>	<b>Gray-Mule-Lim</b>	22 Aug 07-due
<b>Directional Coupler:</b>	772D Dual Directional Coupler		
<b>Attenuator, Variable</b>	HP 8494B DC-18 GHz digital attenuator	157171	22 Aug 06
<b>Attenuator, Variable</b>	HP 8495B DC-18 GHz digital attenuator	157170	22 Aug 06
<b>Attenuator, Fixed</b>	Weinschel Corp DC-18 GHz, various values		
<b>Test Cables:</b>	Low loss test cables custom mfg.		

080907

**Exhibit 12** *continued*      **Measurements required: RF power output.**

PCS - Block	PCS - Channels	Number of carriers	Amplifier Type	# of amplifiers in MCA	Power per Carrier, W/c	Total Power Watts	Results Occupied Bandwidth
<b>7 Carrier Configuration</b>							
A	25 - 175	7	P2PAM	3	17.14	120	Compliant
A	125-275	7	P2PAM	3	17.14	120	Compliant
A + D	225 - 375	7	P2PAM	3	17.14	120	Compliant
B	425 - 575	7	P2PAM	3	17.14	120	Compliant
B	525-675	7	P2PAM	3	17.14	120	Compliant
B + E	625 - 775	7	P2PAM	3	17.14	120	Compliant
F + C	825 - 975	7	P2PAM	3	17.14	120	Compliant
C	925-1075	7	P2PAM	3	17.14	120	Compliant
C	1025-1175	7	P2PAM	3	17.14	120	Compliant
C+G	1125-1275	8	P2PAM	3	17.14	120	Compliant
<b>8 Carrier Configuration</b>							
A	25 - 200	8	P2PAM	3	15.0	120	Compliant
A	100-275	8	P2PAM	3	15.0	120	Compliant
A + D	200 - 375	8	P2PAM	3	15.0	120	Compliant
B	425 - 600	8	P2PAM	3	15.0	120	Compliant
B	500-675	8	P2PAM	3	15.0	120	Compliant
B + E	600 - 775	8	P2PAM	3	15.0	120	Compliant
F + C	825 - 1000	8	P2PAM	3	15.0	120	Compliant
C	925-1100	8	P2PAM	3	15.0	120	Compliant
C	1000-1175	8	P2PAM	3	15.0	120	Compliant
C + G	1100-1275	8	P2PAM	3	15.0	120	Compliant

**RESULTS:**

The **PCS UMTS-CDMA EDPD Transceiver/ AS5ONEBTS-10** was configured in the test setup shown in Figure 12A. For both the 7 carrier and 8 carrier channel configuration the **PCS UMTS-CDMA EDPD Transceiver/ AS5ONEBTS-10** delivered a minimum of 120.0 Watts +2/-0 dB when measured at the J4 output connection. This data is recorded on the Occupied Bandwidth Data Sheets for “Left edge” and “Right Edge” of each frequency Block.

Note: The **PCS UMTS-CDMA EDPD Transceiver/ AS5ONEBTS-10** is a multi channel linear amplifier and its maximum power level is verified at each cell site during setup of the Modular Cell 4.0.

**Exhibit 13**

**SECTION 2.1047 MEASUREMENT OF MODULATION CHARACTERISTICS**

The modulation characteristics and accuracy of the **PCS UMTS-CDMA EDPD Transceiver/ AS5ONEBTS-10** output signal is a function of the input signal which is provided by the UMTS-CDMA Multi Carrier Radio (**MCR-1900**), Model BNJ64, which was previously authorized by the Federal Communications Commission under **FCC ID: AS5ONEBTS-09**, granted 22 February 2005 for all PCS Blocks.

**13.1 - Modulation Description**

The modulation methods used in CDMA drastically differ from those used in a FM analog system. The methods used in evaluating the **EDPD Transceiver’s MCR-1900 / AS5ONEBTS-10** are described in the pertinent standards documents which include **TIA/EIA-97-C** “recommended Minimum performance Standards for Base Stations Supporting Dual-Mode Wideband Spread Spectrum Cellular Mobile Stations” and **3GPP2 C.S0010-0**, December 1999, *Recommended Minimum Performance Standards for cdma2000 Spread Spectrum Base Stations*,. The modulation quantify criteria are as follows:

**13.2 Modulation Requirements – Section 4.2 of TIA/EIA-97-C and 3GPP2 C.S0010-0**

Waveform quality is tested by measuring the waveform quality  $\rho$ , as defined in 6.4.2.1, and code domain power as defined in 6.4.2.2. The range of values for the transmit waveform quality is from 1.0 for a perfect CDMA waveform to 0.0 for a non-CDMA signal. As an example, a base station with a 0.5 dB degradation in its transmit waveform would have a quality,  $\rho$ , of  $10^{-(0.5/10)}= 0.89$ .

**13.3 Minimum Standard ...per Section 4.2.2.3 of 3GPP2 C.S0010-0**

The normalized cross correlation coefficient,  $\rho$ , shall be greater than 0.912 (excess power  $\leq 0.4$  dB).

**13.4 Results**

The **PCS UMTS-CDMA EDPD Transceiver’s MCR-1900** was configured in the test setup shown in Figure 13A. The **MCR-1900** was configured with its pilot channel and the modulation quality measured with an Agilent -E4406A VSA Series Transmitter Analyzer. Measurements were performed at the PCS Channels shown in table 13.1.

PCS Band	Transmit Channel(s)	Measured Rho	Status
A	25	0.99740	Compliant
D	325	0.99891	Compliant
B	450	0.99894	Compliant
E	725	0.99894	Compliant
F	825	0.99895	Compliant
C	1100	0.99896	Compliant
G	1275	0.99867	Compliant

**TABLE 13.1 MCR-1900 Channels for Modulation Characteristics Measurement**

**13.4.1 Results Summary**

For each of the PCS channels tested, the **PCS UMTS-CDMA EDPD Transceiver’s** modulation quality factor, Rho ( $\rho$ ), was measured to be  $\geq 0.99881$ . The **PCS UMTS-CDMA EDPD Transceiver’s AS5ONEBTS-10** transmit signal modulation parameters and constellation for PCS channel 1100 is shown in Figures 13B and 13C below. The data for channel 1100 is representative of the data recorded for the remaining channels listed above and was taken utilizing the Agilent -E4406A VSA Series Transmitter Analyzer. It also verified that the frequency offset is less than (+/- 0.05 PPM) of the frequency assignment.

Figure 13A

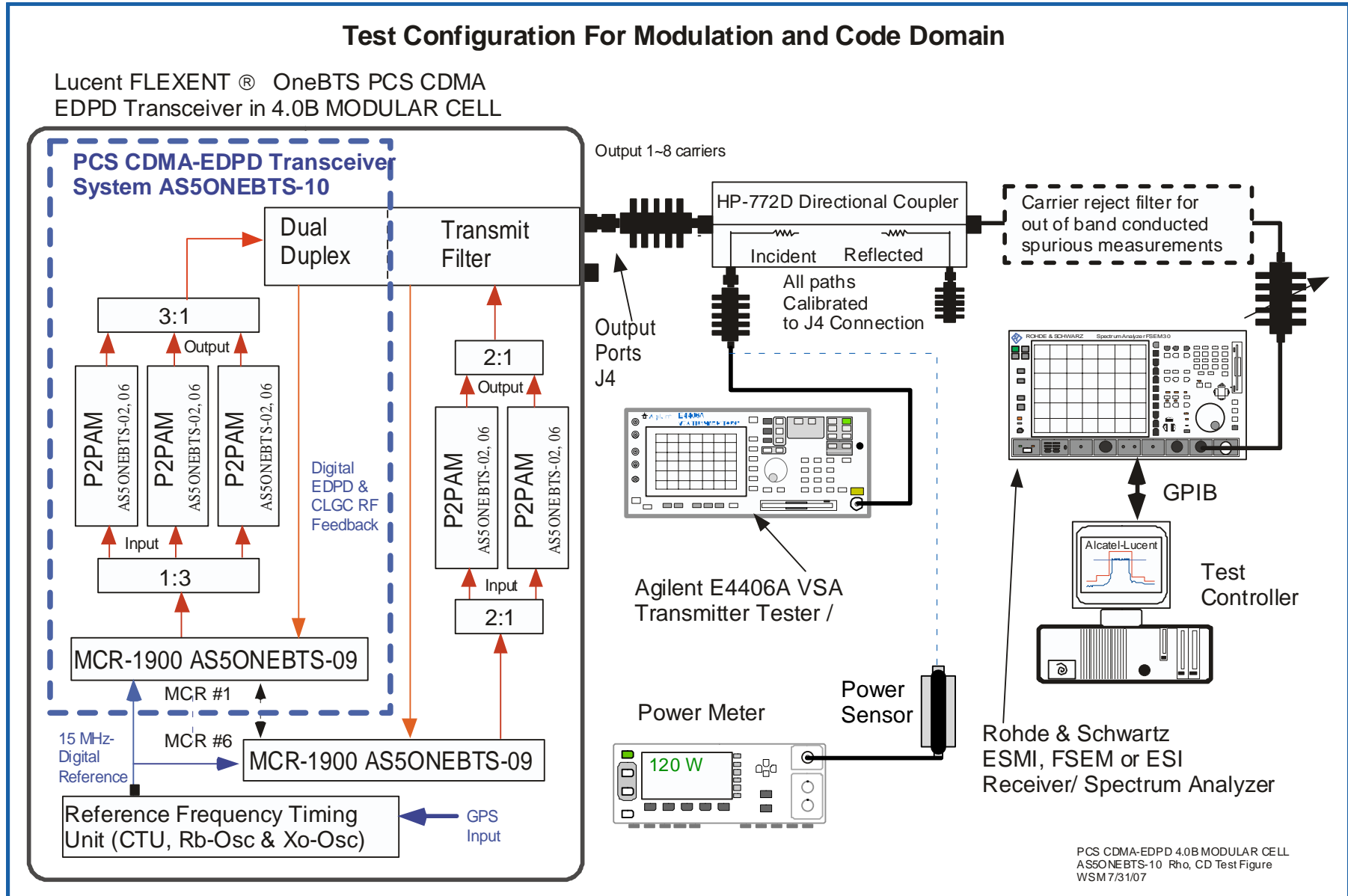

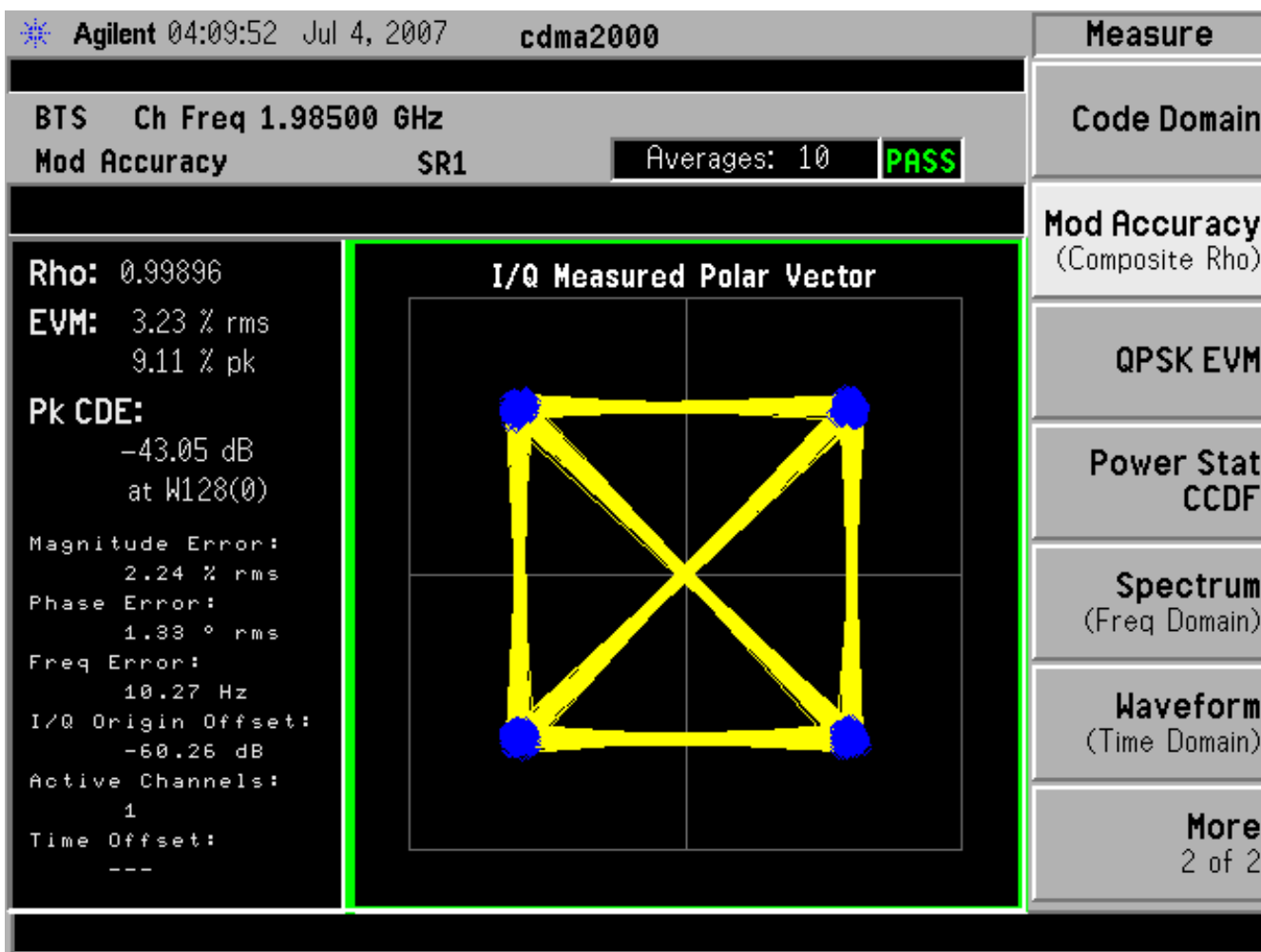

**Figure 13B Code Domain 1c C Block, Channel 1100 Tx Output 1 Amplifier**



- Measure
- Channel Power
- ACPR
- Intermod
- Spectrum Emission Mask
- Occupied BW
- More 1 of 2

Figure 13C Rho 1c C Block, Channel 1100 Tx Output 1 Amplifier



## Exhibit 14 MEASUREMENT OF OCCUPIED BANDWIDTH

### SECTION 2.1049 Measurement Of Occupied Bandwidth

Occupied bandwidth measurements were performed for the MCA configurations pertinent to G Block operation of the PCS UMTS-CDMA EDPD Transceiver. This documents the typical performance of the PCS UMTS-CDMA EDPD Transceiver while operating with one through three CDMA carriers. All power adjustments were performed via the MCR/ AS5ONEBTS-09. The measurement of the 7 and 8 carrier 17.14/15W cases are described below.

The occupied bandwidth of the PCS UMTS-CDMA EDPD Transceiver/ FCC ID: AS5ONEBTS-10 was measured using a Rohde & Schwarz FSEM-30 Spectrum Analyzer, a PC based instrumentation controller using TILE™ software and calibrated RF attenuation and coupled signal path. The RF power level was measured and adjusted via the test setup in Figure 14A. The set RF output from the transmitter was reduced by calibrated broadband attenuators to amplitudes usable by the spectrum analyzer and power meter. The attenuation factors are reflected in the displayed values of the charts. The typical occupied bandwidth measurement displays the signal adjusted to the -16.2 dBc level corresponding to the corrected RF power level for a 30 kHz resolution bandwidth (RBW). This set-point was performed as follows:

For each test the power calibration was individually verified at the transmitter antenna connection (J4) with a power meter by using the test setup depicted in Figure 14A. The power calibration was performed to calibrate the setting power meter measurement as a reference for both the measured 30 kHz Occupied Bandwidth signal at the -16.2 dBc line and a 3 MHz RBW measurement against the “Top of Mask” limit. The “Top of Mask” limit corresponds to a single carrier signal at the specified power level (i.e 15W or 17.14W) as measured with an RBW of  $\geq 1.25$  MHz. Since at the transmitter J4 output there may be multiple CDMA carriers, the measurement is made with an RBW setting of 3 MHz which is greater than the individual 1.25 MHz signal bandwidth. These power calibration measurements were performed along with each Occupied Bandwidth measurement. The signals measured at RBW's of 3 MHz and 30 kHz were corrected for path loss and were plotted against the mask limit. As part of the calibration between the power meter measurement and the test analyzer, software was used to place the 3 MHz RBW signal either at the “Top of Mask” for single carriers or at the carrier power calibration line for multi-carrier signals. The carrier as measured with 3 MHz and 30 kHz RBW were corrected with the same attenuation factors. The two measurements are co-plotted on the same graph. A typical single carrier example is shown in Figure 14B which depicts a single carrier (825 F Block) inside the mask for the three carrier F Block.

This test procedure above calibrates the carrier power to the “Top of Mask” and accurately places the 30 kHz RBW measured carrier at the -16.2 dBc reference line. This process also documents the carrier power at the specified power level of 17.14 or 15 watts per carrier 120 Watts total. All of the plots are presented with a sufficiently wide frequency span for the specific signals or Block of interest. This allows for ease of comparison of the multi-carrier performance. This data was electronically recorded using the TILE™ software and electronically placed in the Occupied Bandwidth Data Sheets. These sheets contain data for “Left Edge of Block”, and “Right Edge of Block” for each PCS frequency Block. Since the 5 MHz (3 carrier) Blocks are too narrow for 7 and 8 eight applications data was collected for combined AD, BE, FC and CG configurations.

#### Block Organization and Tests Performed

The FLEXENT PCS Modular Cell 4.0B product line utilizes 60 MHz or 65 MHz MHz transmit filters. The use of EDPD provides the spurious control which allows the use of wide bandwidth filters such as the 60/65 MHz Full PCS Band filters. The 60 MHz PCS Transmit Band filters provide for the least spurious reduction at “edge of block” and “edge of band” and thus represent the most difficult compliance configuration. The filter does not provide for any spurious reduction at block edges inside the band. The testing of EDPD documented herein were performed with the 60 or 65 MHz band filter. This configuration is therefore the most difficult for compliance demonstration.

**Exhibit 14** *continued*

The demonstration of compliance for the 7 and 8 carrier 3 P2PAM EDPD Transceiver configurations were performed for operation in all Blocks. Data for this Class II change is constrained to the 7 carrier 17.1 W/c and 8 carrier 15 W/c configurations.

In order to adequately evaluate performance the worst case modulation factors of 2G Voice ( vs. 3G1X or 3G1X-EV-DO) were used from the governing documents. Thus, the applied signal, from a **PCS UMTS-CDMA EDPD Transceiver/ FCC ID: AS5ONEBTS-10**, met the recommended characteristics per "**Table 6.5.2-1 Base Station Test Model, Nominal**" from **3GPP2 TSG-C.S0010-C-v1.00, February 2005**, Recommended Minimum Performance Standards for cdma2000 Spread Spectrum Base Stations, as defined below in table 14.1.

Type	Number of Channels	Fraction of Power (Linear)	Fraction of Power (dB)	Comments
Pilot	1	0.2	-7	Code channel $W_0^{128}$
Sync	1	0.0471	-13.3	Code channel $W_{32}^{64}$ ; always 1/8 rate
Paging	1	0.1882	-7.3	Code channel $W_1^{64}$ ; full rate only
Traffic	6	0.09412	-10.3	Variable code channel assignments; full rate only

**TABLE 14.1 Base Station Test Model, Nominal for Main Path**

Type	Number of Channels	Fraction of Power (Linear)	Fraction of Power (dB)	Comments
Transmit Diversity Pilot	1	0.2	-7	Code channel $W_{16}^{128}$
Traffic	6	0.09412	-10.3	Variable code channel assignments; full rate only

**TABLE 14.2 Base Station Test Model, Nominal for Transmit Diversity Path**

The FCC limits contained in **47CFR 24.238 1-Oct-2005** were followed along with the minimum standard presented in **3GPP2 TSG-C.S0010-B-v2.0 March 2004**. Where combinational measurements of 3G1x-EV-DO are made along with the 2 GV configuration above the applied signal were based upon the 3GPP2 TSG-C.S0032-1 titled "Recommended Minimum Performance Standards for CDMA2000 High Rate Packet Data Access Network ". Section 3.1.2.4 Limitations on Emissions. This standard covers the emissions situation except that we use the maximum 25 MAC full traffic configuration as the standard.

**Exhibit 14** *continued*

**Measurement Offset**

The spectrum analysis output plots shows the peak of the CDMA channel signal 16.19 dB below the Mask reference / “zero dBc line” of the spectrum analyzer for the following reason: For the CDMA system there is no carrier without modulation. Since the CDMA signal is broadband and 1.25 MHz wide, all measurements performed at narrower resolution bandwidths need be adjusted for the reduction in signal energy. The following relationship was used to provide the correct level for an unmodulated carrier vs. the modulated signal.

$$10 \cdot \log (\text{Resolution Bandwidth} / \text{Transmit Bandwidth}) = \text{Signal Offset} \quad (1)$$

For the peak of the 1.25 MHz CDMA signal measured with a RBW of 30 kHz the signal offset is:

$$\text{Signal Offset} = 10 \cdot \log (30 \text{ kHz} / 1.25 \text{ MHz} ) = -16.19 \text{ dB}$$

Limits which are specified as appropriate at a given RBW can be measured and evaluated at other RBW’s if the limit is adjusted per equation (1)

**Require Levels**

The minimum standard presented in 3GPP2 TSG-C.S0010-B-v2.0 March 2004 was followed for Suppression Inside the Licensee’s Frequency Block(s)

Signals that are within the base station transmit band of 1930.000 to 1990.000 MHz and are within the specific block(s) allocated to the operator's system, the total conducted spurious emissions in any 30 kHz band greater than 885 kHz from the CDMA channel center frequency shall not exceed a level of -45 dBc....

The Limit in 47 CFR 24.238(a)(b) for emissions in the 1 MHz band immediately outside and adjacent to a licensee's frequency block is:

Emissions  $\leq 1$  MHz outside the Block *when measured with a RBW of 1%* of the emissions Bandwidth shall be attenuated by :

$$-\{43+10\log (\text{mean power output in watts})\} = -13 \text{ dBm}$$

The Limit in 47 CFR 24.238(a) for emissions outside a licensee's frequency block is:

Emissions  $> 1$  MHz outside the Block, *when measured with a RBW of 1 MHz*, shall be attenuated by :

$$-\{43+10\log (\text{mean power output in watts})\} = -13 \text{ dBm.}$$

Measurement at a Resolution Bandwidth of 30 kHz is based on our experience with 47 CFR 24.238 and lacking other guidance.

**Adjusted Levels**

The following levels apply when measurements of the above limits are performed with an RBW of 30 kHz. Measurement at a Resolution Bandwidth of 30 kHz is based on our experience with 47 CFR 24.238 and lacking other guidance.

1. On any frequency removed from the carrier center frequency by greater than 885 kHz up to 1.25 MHz - at least 45 decibels below the carrier; and
2. On any frequency removed from the carrier center frequency by greater than 1.25 MHz to 2.25 MHz the level shall not exceed -9.2 dBm when measured in a 30 kHz resolution bandwidth (Note 2 below).  
*For 17.14 Watts/carrier* the required level is -9.2 dBm/ -51.54 dBc.  
*For 15.0 Watts/carrier* the required level is -9.2 dBm/ -50.96 dBc. and
3. From the edge of the Block to the 10th harmonic of the carrier at least

$$-\{43+10\log (\text{mean power output in watts})\} \text{ dBm.}$$

**Exhibit 14** *continued*

*For 17.14 Watts* the required level is -70.54 dBc / -28.2 dBm as measured with a 30 kHz resolution bandwidth (see Note 3).

*For 15 Watts* the required level is -69.96 dBc / -28.2 dBm as measured with a 30 kHz resolution bandwidth (see Note 3). This is equal to -13 dBm measured with a 1 MHz resolution bandwidth

+++++

**Note 2:** The -9.2 dBm level was computed as follows: The limit is specified as

$$-\{43+10\log(\text{mean power output in watts})\} \text{ dB} = -13 \text{ dBm}$$

When measured in a resolution bandwidth not less than 1% of the signal bandwidth.

Since the carrier is a 1.25 MHz bandwidth signal, the limit is adjusted to

$$-13 + 10\text{LOG}(30\text{kHz}/15 \text{ kHz}) \text{ dBm} = -9.2 \text{ dBm}; \text{ which given a } 42.34 \text{ dBm carrier (17.14W) equals } -51.54 \text{ dBc}$$

or

$$-13 + 10\text{LOG}(30\text{kHz}/15 \text{ kHz}) \text{ dBm} = -9.2 \text{ dBm}; \text{ which given a } 41.76 \text{ dBm carrier (15W) equals } -50.96 \text{ dBc}$$

**Note 3:** The -28.2 dBm level is computed from -13 dBm measured with a 1 MHz resolution bandwidth adjusted by :

$$-13 + 10\text{LOG}(30\text{kHz}/1.0 \text{ MHz}) \text{ dBm} = -28.2 \text{ dBm}; \text{ which given a } 42.34 \text{ dBm carrier (17.14W) equals } -70.54 \text{ dBc}$$

or

$$-13 + 10\text{LOG}(30\text{kHz}/1.0 \text{ MHz}) \text{ dBm} = -28.2 \text{ dBm}; \text{ which given a } 41.76 \text{ dBm carrier (15W) equals } -69.96 \text{ dBc}$$

**Mask Description for Single Carrier applications at 17.14 W**

The Mask limits are identical for the left and right side of the PCS Blocks and are as follows:

Figure 14B shows the Mask limit for PCS channel 825 which is the left block edge for Block F and shows limits levels identical for the band edge of the PCS band. The Spectrum Analyzer reference level is set above the Signal Reference to allow for the necessary dynamic range of a three CDMA carrier presentation. The top of a typical 17.14 Watt / 42.34 dBm single carrier CDMA signal viewed at a resolution bandwidth of 30 kHz is shown at the 26.14 dBm/ -16.23 dBc line. This line is based on equation 1, and the ratio of the 1.25 MHz bandwidth and the 30 kHz resolution bandwidth of the spectrum analyzer. The vertical line from a to b (i.e. a-b) is at 885 kHz from the center of channel 825 (i.e. Fc), per 3GPP2 TSG-C.S0010-B-v2.0. The horizontal line b-c is 45 dB below the 42.34 dBm/ 0 dBc reference level. The vertical line c-d is at 1.25 MHz from the center of the channel. The placement of line d-e is derived from evaluation of the signal and 15 kHz (1%) resolution bandwidth, using the suggested value in section 24.238 of the rules. The ratio of 30 kHz to 15 kHz in equation (1) gives 3.8 dB. Adjusting the tolerance line to reflect this difference puts the -13 dBm limit line at -9.2 dBm or -51.54 dBc below the reference line. The vertical line, e-f is at 2.25 MHz from the center of channel 25. The horizontal line f-g is drawn at -70.54 dBc below the 0 dBc / 42.34 dBm reference because the rules require a 1 MHz resolution bandwidth for measurements 1 MHz or greater outside the PCS band. Again, equation (1) and the ratio of 1 MHz to 1.25 MHz provides this value. The same logic was used in determining the other block and band edge tolerances.

**Mask Description for Multiple Carriers**

Figure 14B and 14C shows the Mask limit for PCS Block F which is channels 825-875. The mask for multiple carriers only adjusts the width of the carrier portion of the mask. For the example given above...with multiple carriers there would be no adjustments made to the "Left Edge of Block" requirements. The specified "Right Edge Limit" is treated as an expansion of the non Block edge corner **bb** to be the required + 885 kHz from the center of the "right most" channel. The "Right Edge of Block" limits were derived consistently.

## Exhibit 14 *continued*

### Trace Description and Power Calibration

Figure 14B shows the single carrier CDMA signal measured with two different resolution bandwidths. The additional upper magenta trace displays the signal as measured with a resolution bandwidth of 3 MHz. The black trace is the same signal as measured with a 30 kHz resolution bandwidth and is the appropriate trace for the mask evaluation. The wider resolution bandwidth allows for a true power calibration of the measured signal against the top of mask. The top of the mask is appropriate for a single carrier power calibration as it represents the true power level of a single carrier as measured with a power meter. For a two carrier signal the total power is 3 dB higher. For three carrier signals the total power is 4.77 dB higher when measured with a resolution bandwidth greater than signal bandwidth of 3.75 MHz. The spectrum analyzer bandwidth is only 3 MHz and therefore a correction factor is necessary. The bandwidth correction factor for the 3 carrier signal is therefore:

$$4.77 \text{ dB} - 10 \cdot \text{LOG}(3.75/3) \text{ dB} = + 3.80 \text{ dB}$$

The Power Calibration level for 3 or more carriers equals:

$$\text{Single Carrier Power level (dBm)} + 4.77 - 10 \cdot \text{LOG}(3.75/3) = \text{Single Carrier Power level (dBm)} + 3.80 \text{ dB}$$

The power calibration values for the 17.1 W/c - 7 carrier and 15 W/c - 8 carrier configurations is 42.34 dBm and 41.76 dBm respectively. These values are depicted on the occupied bandwidth charts as the dashed magenta Power Calibration Line h-hh on each chart.

### Measurement of the 7 Carrier Configuration

All of the tolerance lines for the output are referenced to the top of the Occupied Bandwidth mask, which is defined as 42.34 dBm/ zero dBc. For all measurements of the **PCS UMTS-CDMA EDPD Transceiver/ FCC ID: AS5ONEBTS-10** Occupied Bandwidth, the output power was measured / adjusted individually to the 17.14 W level for each carrier and this is the 42.34 dBm value at the 0 dBc reference line.

In order to depict the tolerance lines that are required by Sec 24.238 of the FCC Rule and 3GPP2 C.S0010-0, all measurements were made with a resolution bandwidth of 30 kHz and the limits were adjusted using equation (1). A sample detector was employed using minimum of 25 sweeps averaging per trace.

### Measurement of the 8 Carrier Configuration

All of the tolerance lines for the output are referenced to the top of the Occupied Bandwidth mask, which is defined as 41.76 dBm/ zero dBc. For all measurements of the **PCS UMTS-CDMA EDPD Transceiver/ FCC ID: AS5ONEBTS-10** Occupied Bandwidth, the output power was measured / adjusted individually to the 15 W level for each carrier and this is the 41.76 dBm value at the 0 dBc reference line.

In order to depict the tolerance lines that are required by Sec 24.238 of the FCC Rules and 3GPP2 C.S0010-0, all measurements were made with a resolution bandwidth of 30 kHz and the limits were adjusted using equation (1). A sample detector was employed using minimum of 25 sweeps averaging per trace.

**Exhibit 14** *continued*

PCS - Block	PCS - Channels	Number of carriers	Amplifier Type	# of amplifiers in MCA	Results Occupied Bandwidth
<b>7 Carrier Configuration</b>					
A	25 - 175	7	P2PAM	3	Compliant
A	125-275	7	P2PAM	3	Compliant
A + D	225 - 375	7	P2PAM	3	Compliant
B	425 - 575	7	P2PAM	3	Compliant
B	525-675	7	P2PAM	3	Compliant
B + E	625 - 775	7	P2PAM	3	Compliant
F + C	825 - 975	7	P2PAM	3	Compliant
C	925-1075	7	P2PAM	3	Compliant
C	1025-1175	7	P2PAM	3	Compliant
C+G	1125-1275	7	P2PAM	3	Compliant
<b>8 Carrier Configuration</b>					
A	25 - 200	8	P2PAM	3	Compliant
A	100-275	8	P2PAM	3	Compliant
A + D	200 - 375	8	P2PAM	3	Compliant
B	425 - 600	8	P2PAM	3	Compliant
B	500-675	8	P2PAM	3	Compliant
B + E	600 - 775	8	P2PAM	3	Compliant
F + C	825 - 1000	8	P2PAM	3	Compliant
C	925-1100	8	P2PAM	3	Compliant
C	1000-1175	8	P2PAM	3	Compliant
C + G	1100-1275	8	P2PAM	3	Compliant

**TABLE 14.2 PCS Occupied Bandwidth Compliance Tabulation**

**Exhibit 14 Results**

*The Block designation, PCS channels, frequencies and Measured RF Power are tabulated on each plot. The transmitter output signals are plotted for each frequency/ channel of interest. Plots are provided for Left Edge and Right Edge of each PCS Block evaluated. These frequencies were chosen to show the occupied bandwidth in the channels in each of the PCS Blocks in which this product can be operated, in compliance with Section 24.229 and 24.238 (c) of the Commission code. The signal used to show the occupied bandwidth is defined in table 14.1. This is the signal recommended in 3GPP2 C.S0010-0 The power output level was adjusted to provide the documented value on each chart.*

**RESULTS:** The following exhibits illustrate the spectrums investigated and document compliance.  
**W. Steve Majkowski NCE**



Figure 14A Test Setup for Antenna Port Measurement of Transmit Power, Occupied Bandwidth and Conducted Spurious Emissions

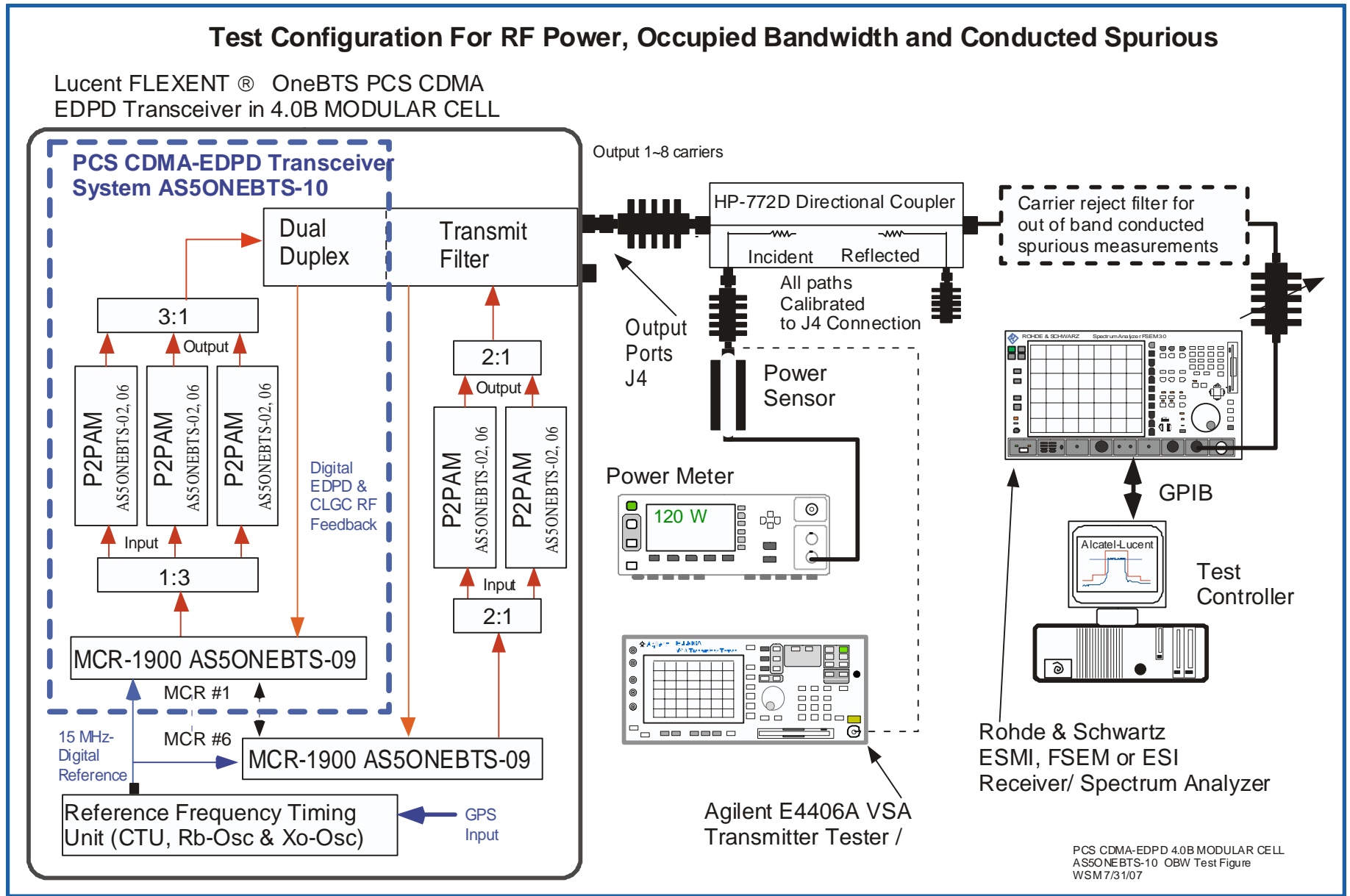
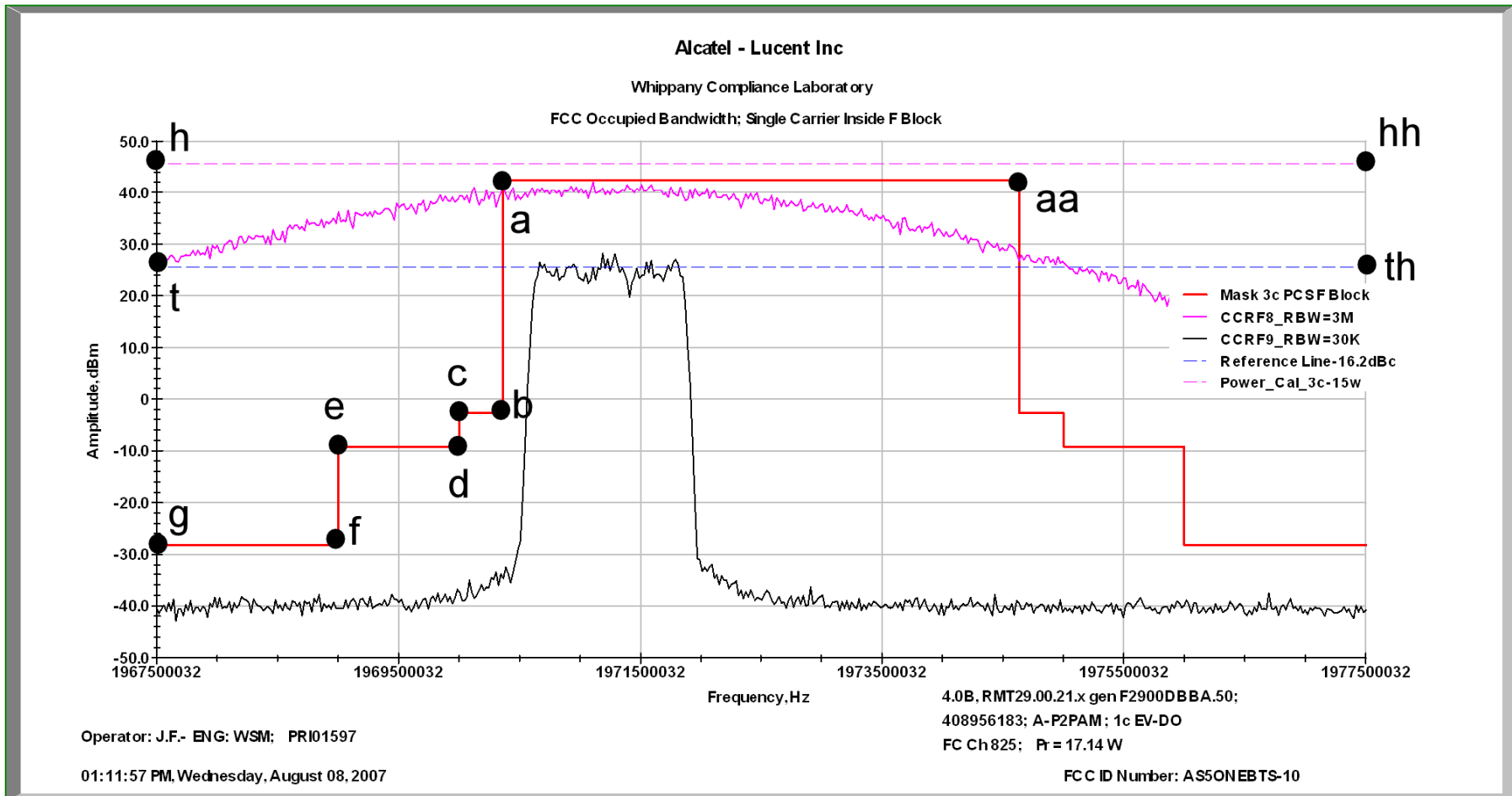
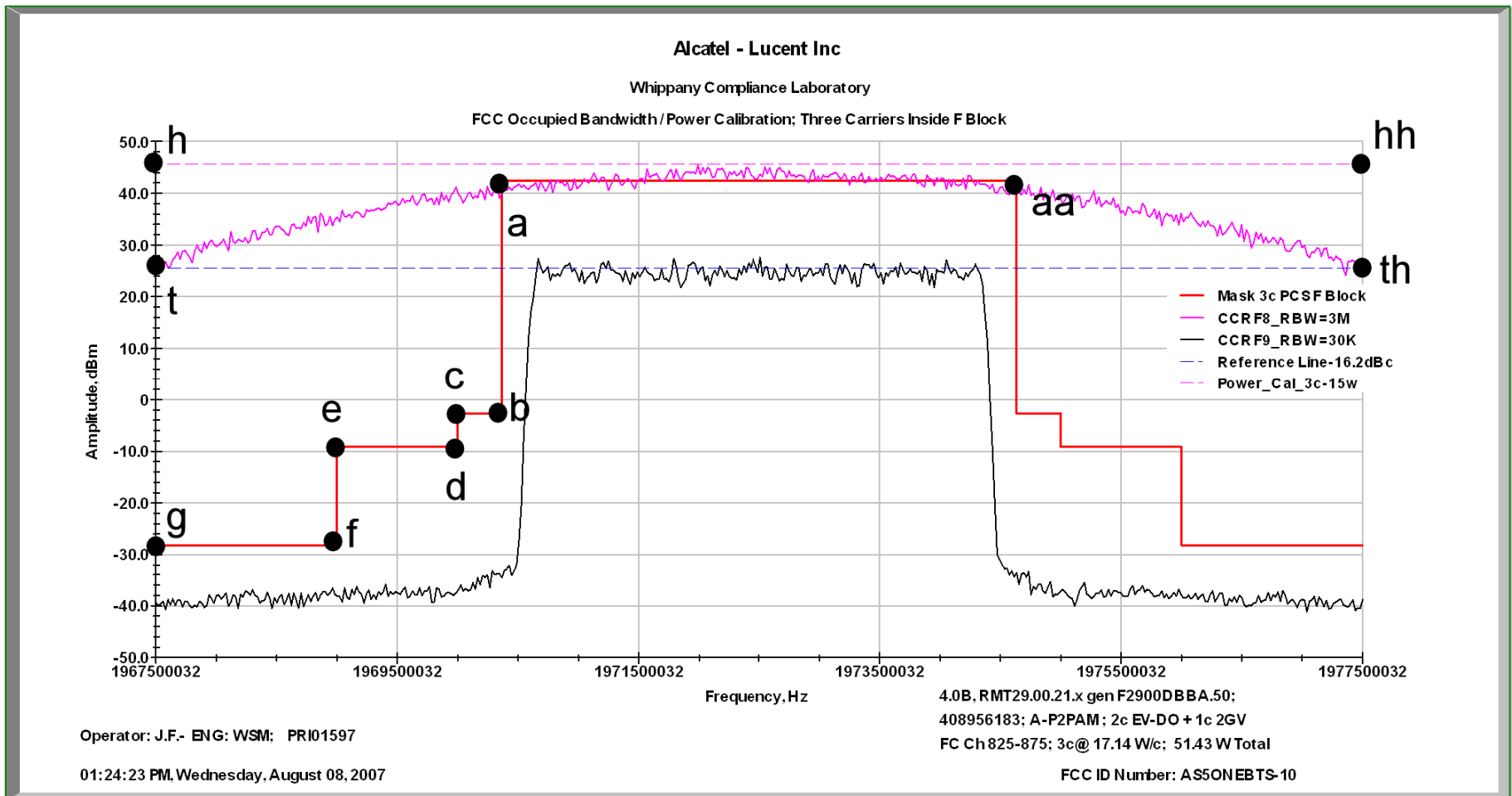

Figure 14B Occupied Bandwidth Mask for PCS Block Operation at 17.1 W (F Block, Single carrier depicted)



**Figure 14C Occupied Bandwidth Mask for PCS Block Operation at 17.1 W  
(PCS F Block is depicted with a three carrier signal showing use of the Power calibration line h-hh)**



**Transmitter Measurements  
of  
CDMA Occupied Bandwidth  
for  
Lucent Technologies Inc.  
PCS UMTS-CDMA EDPD Transceiver  
FCC ID: AS5ONEBTS-10  
Installed in  
FLEXENT PCS CDMA Modular Cell 4.0  
Operational Configurations  
8c at 15W/carrier, 120W Total  
and  
7c at 17.1W/carrier, 120W Total**

W.Steve Majkowski NCE  
Lucent Technologies Inc.  
Whippany FCC Compliance Laboratory  
Office: 973-386-3812  
Lab: 973-386-2434  
majkowski@lucent.com

**Occupied Bandwidth  
Test Report  
AS5ONEBTS-10  
8c at 15 W/carrier 120 Watts Total  
using  
3x P2PAMs**

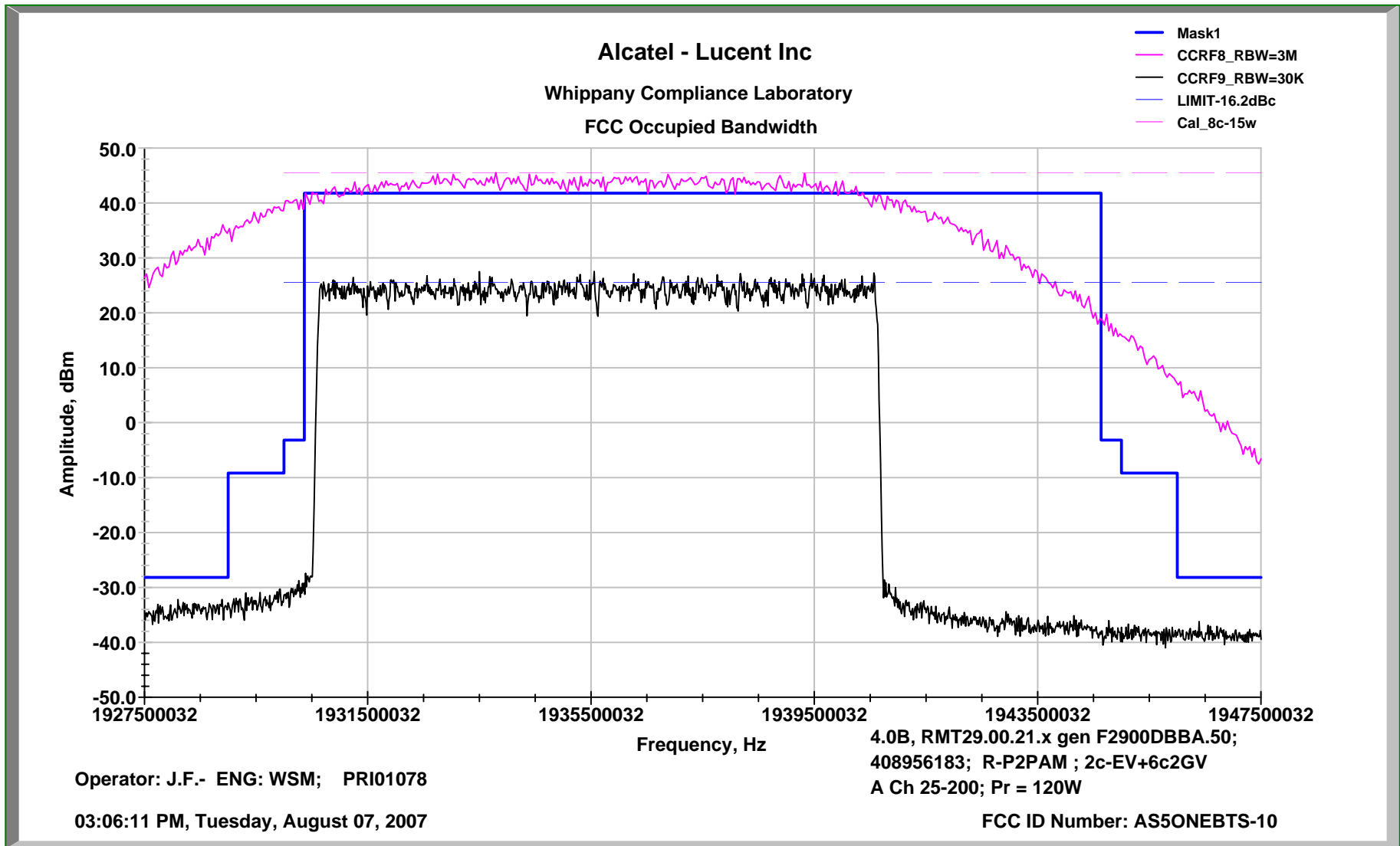

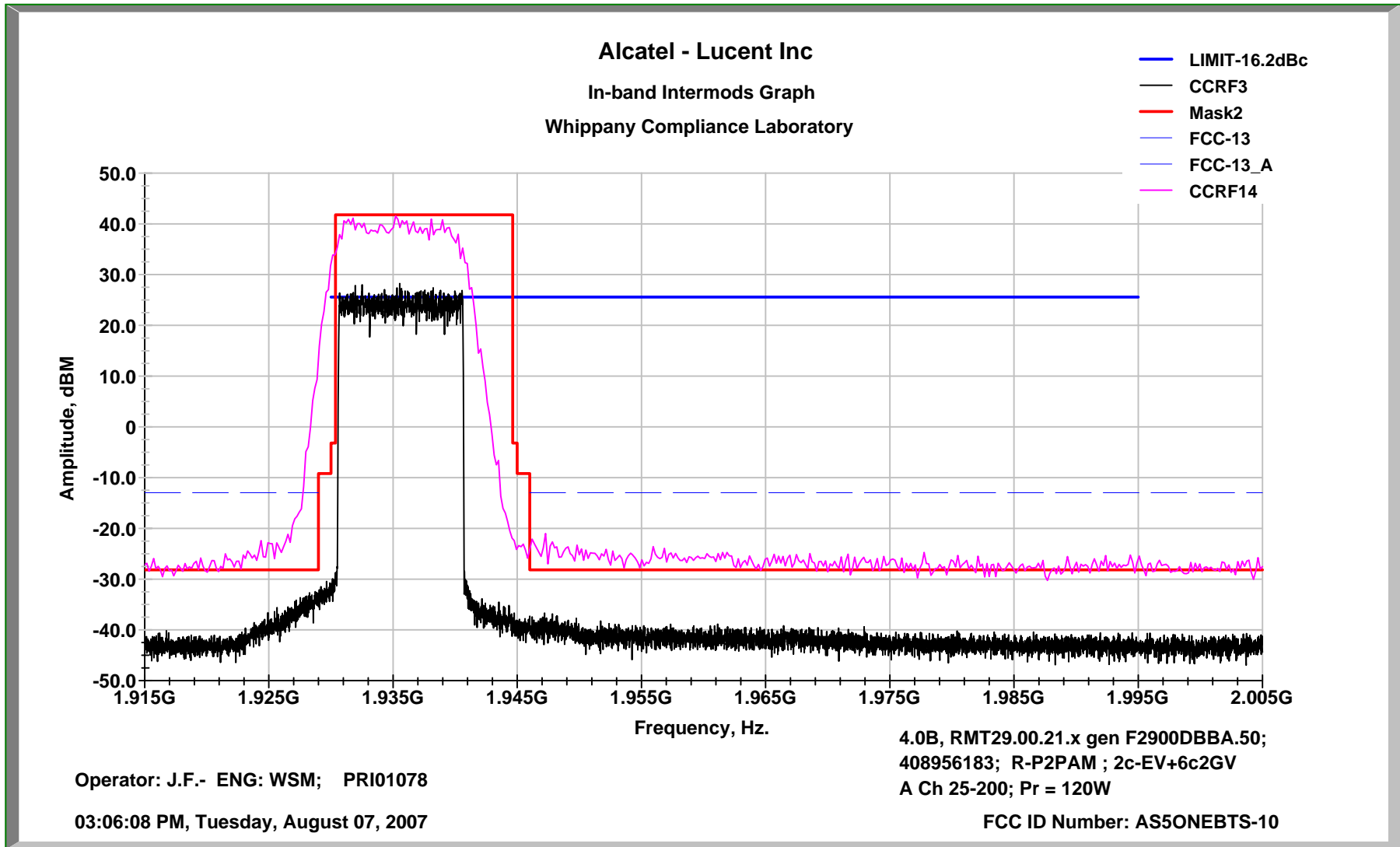

Occupied Bandwidth 8cx3A Block A5 Ch 100-275

J4=120W

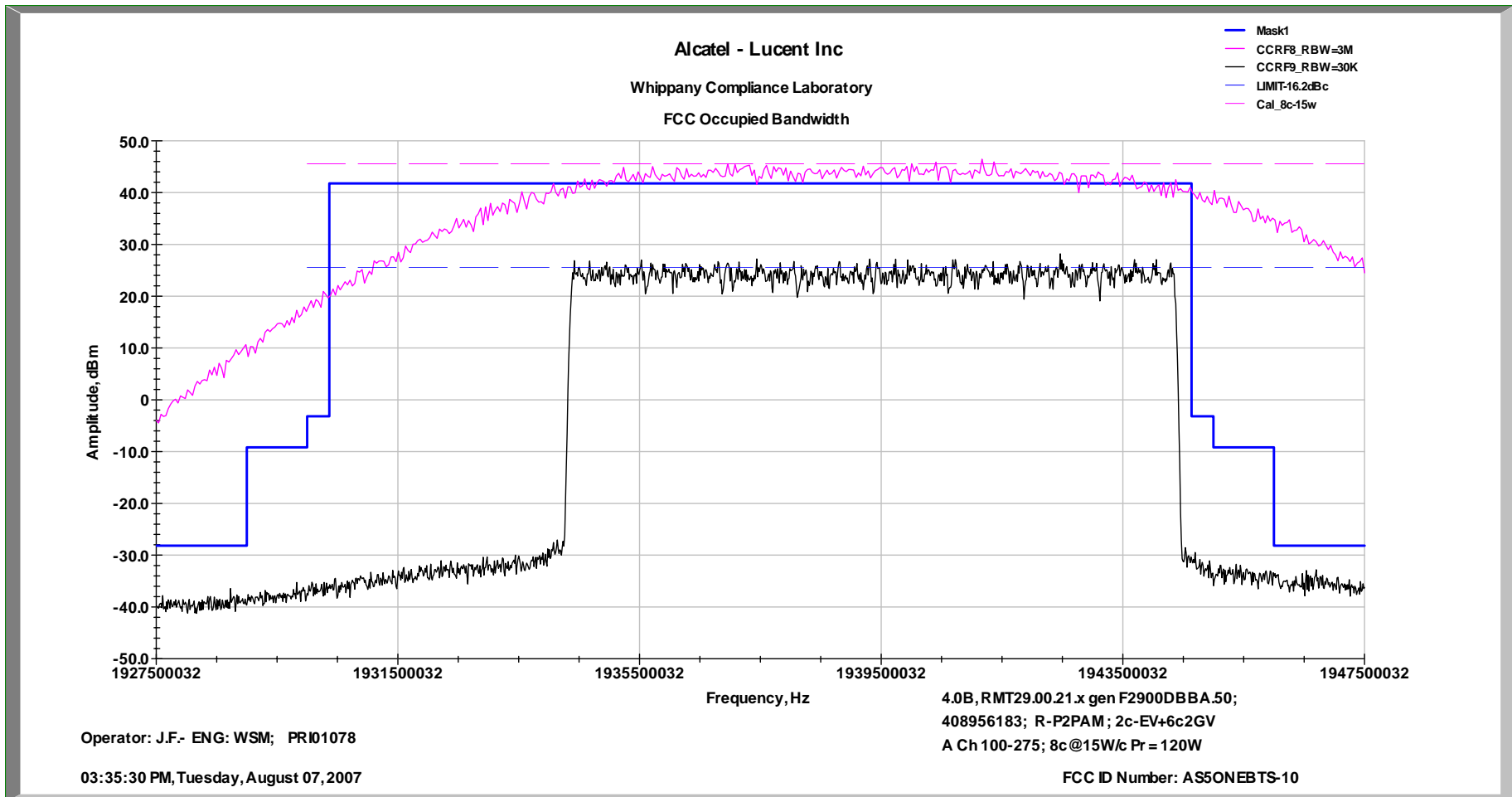



In-Band Intermods

8cx3A Block A5 Ch 100-275

J4=120W

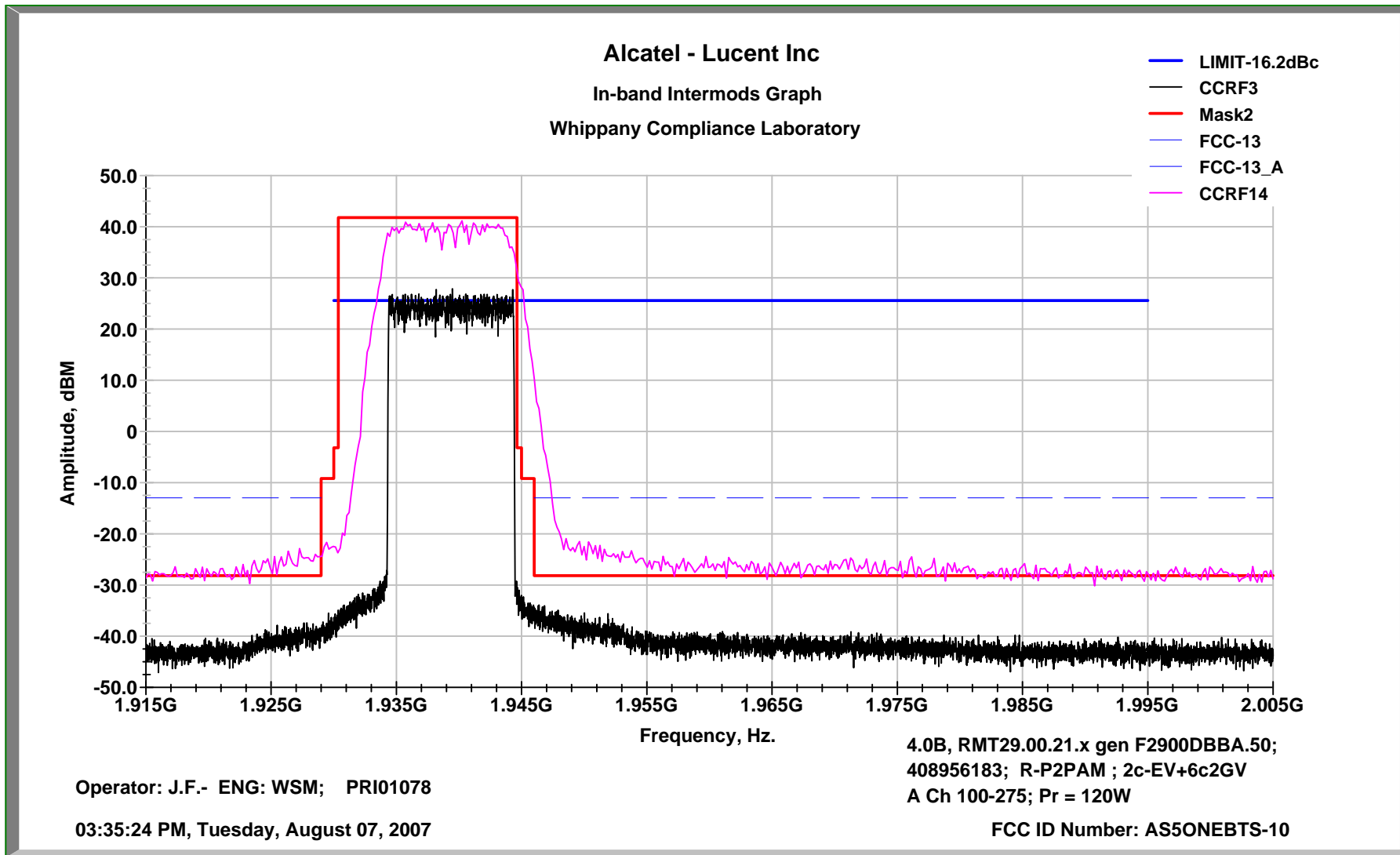

Occupied Bandwidth 3x3A Block AD Ch 200-375

J4=120W

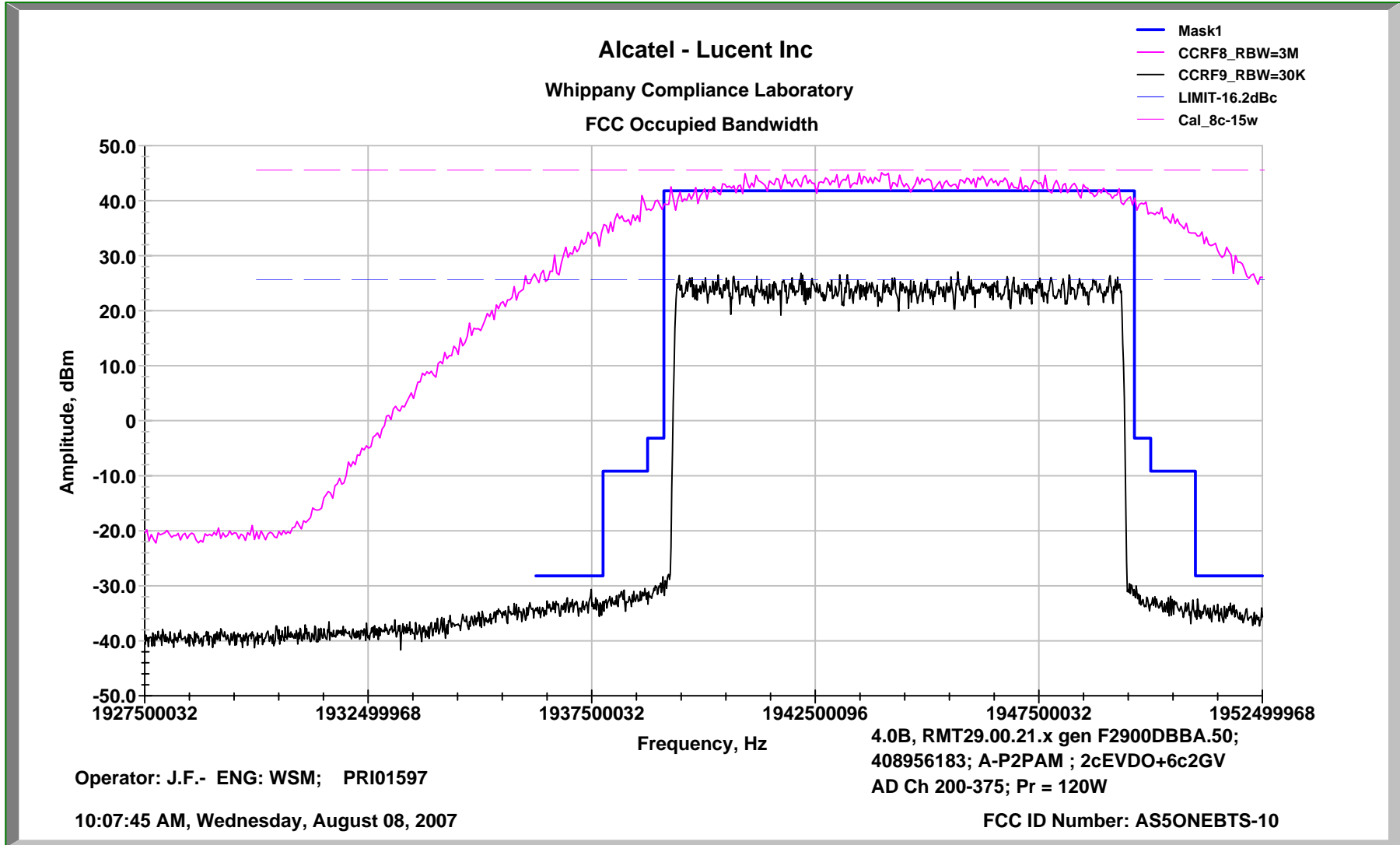

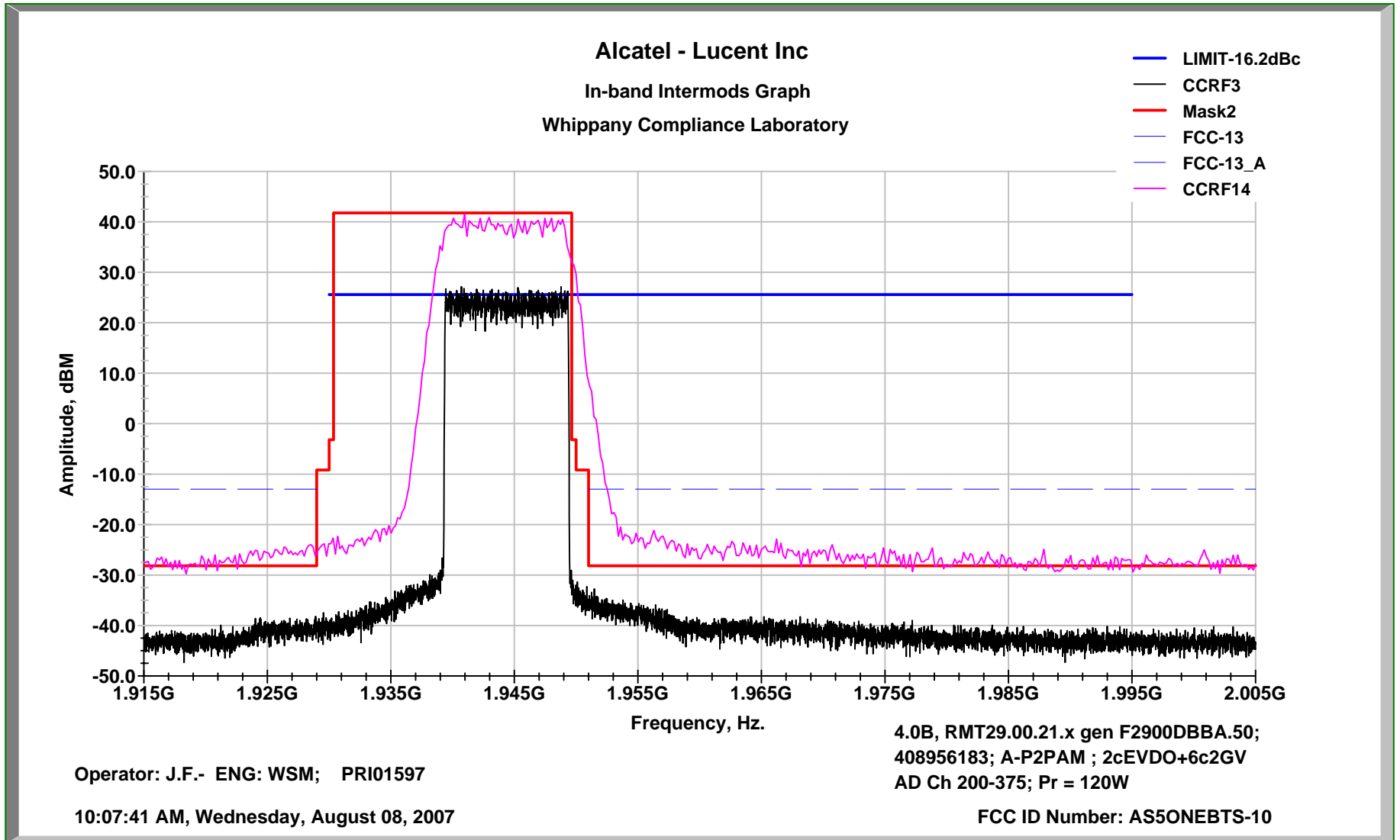

Occupied Bandwidth 8cx3A Block B1 Ch 425-600

J4=120W

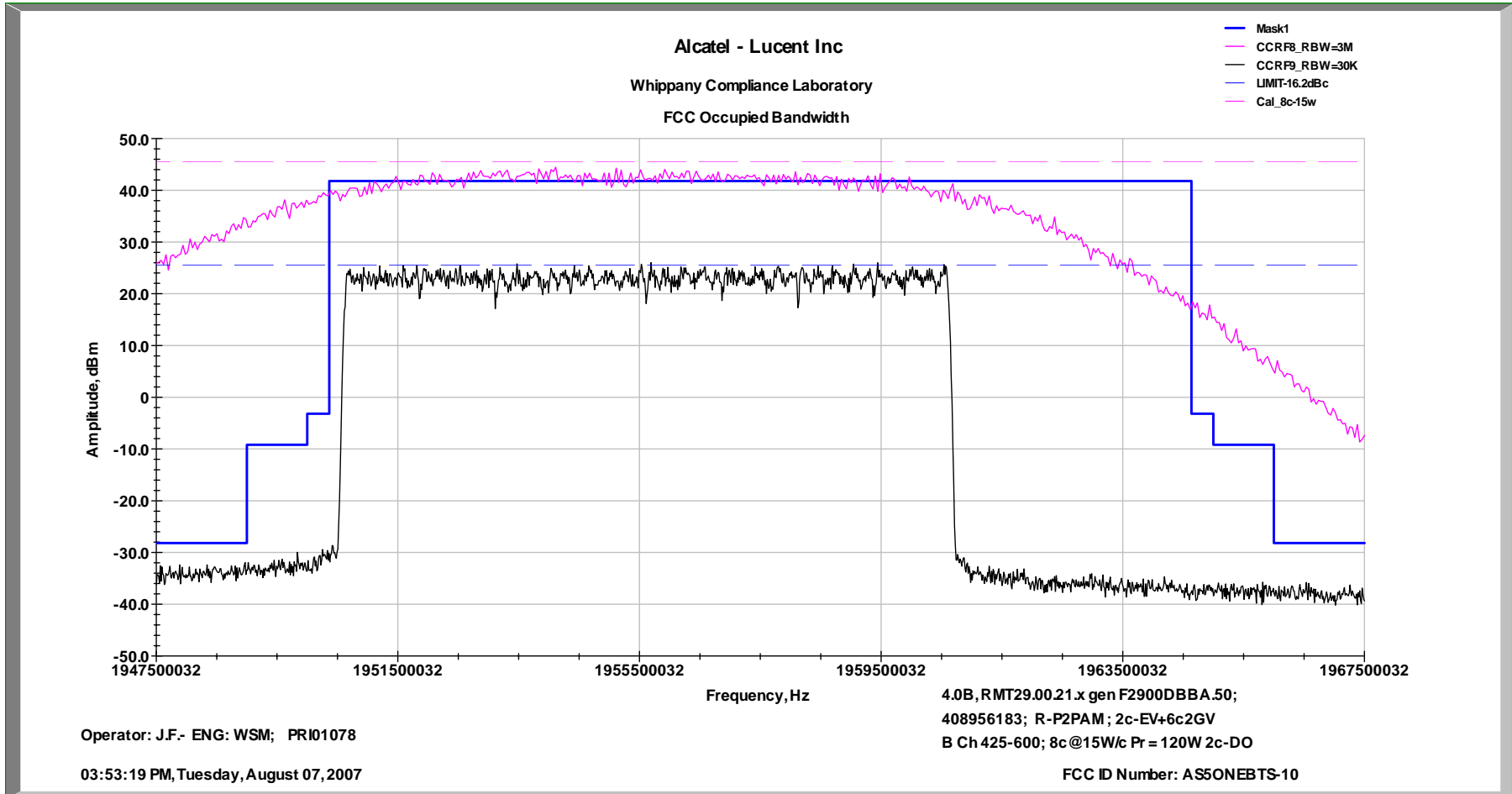

In-Band Intermods

8cx3A Block B1 Ch 425-600

J4=120W

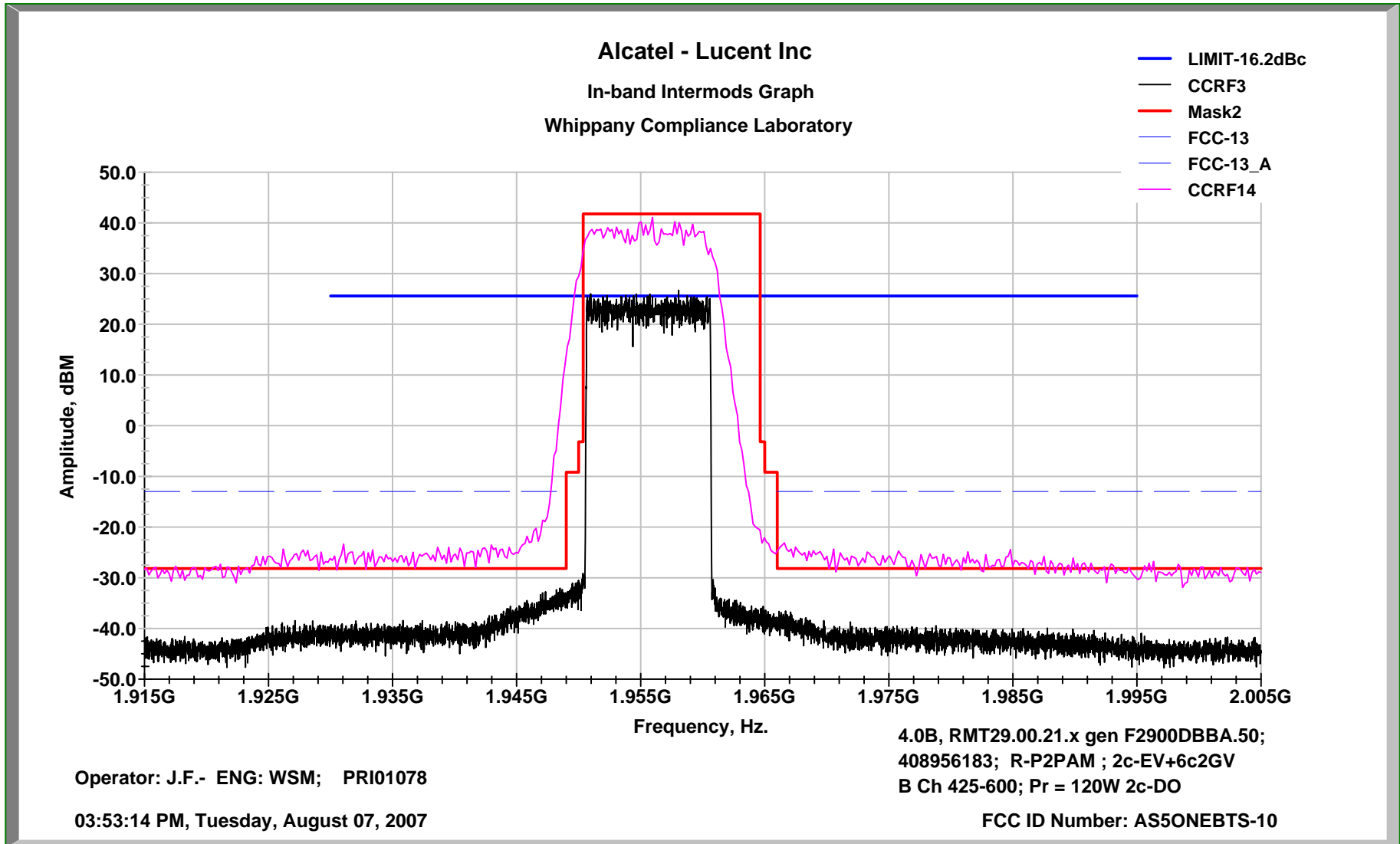

Occupied Bandwidth 8cx3A Block B5 Ch 500-675

J4=120W

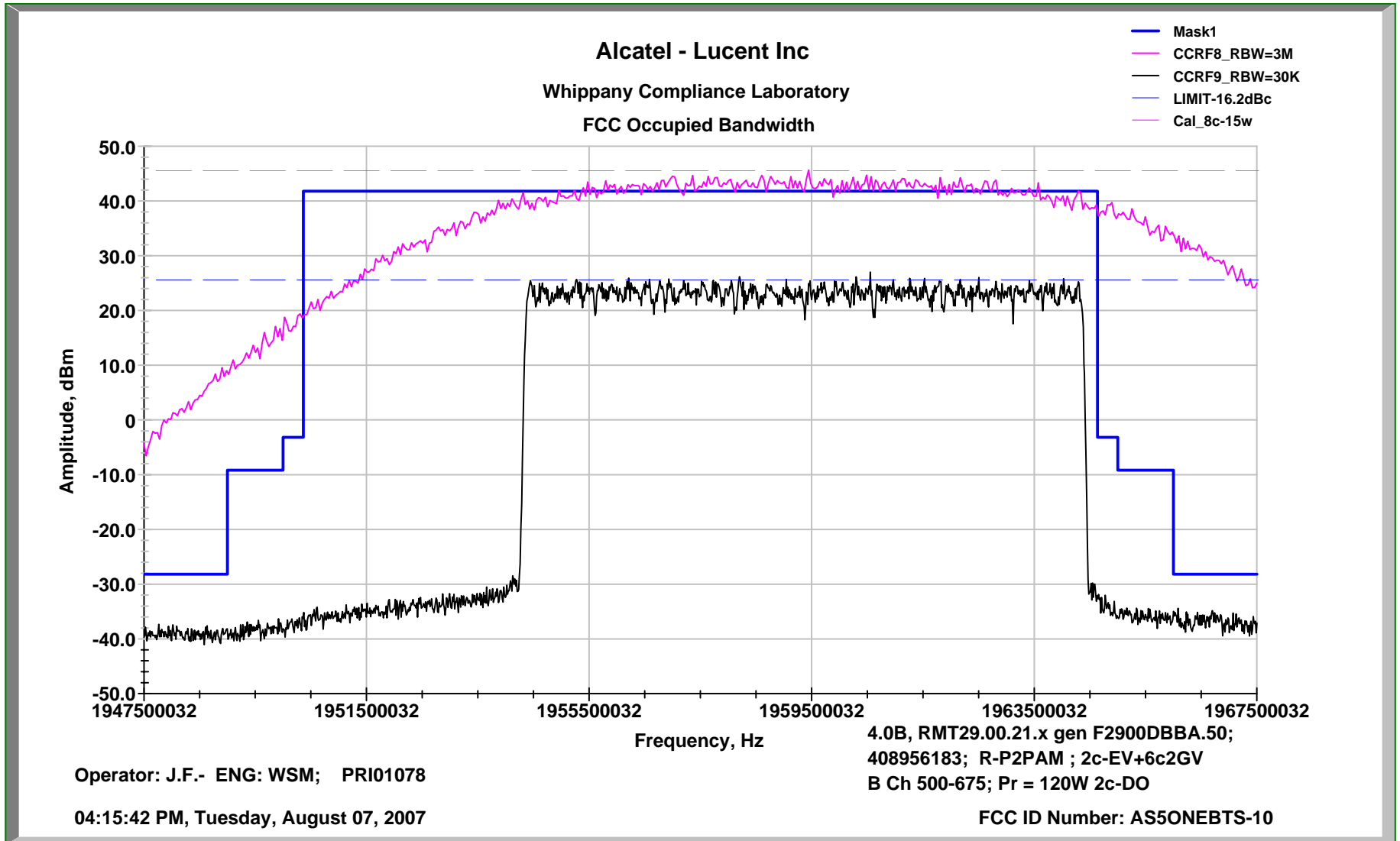

In-Band Intermods

8cx3A Block B5 Ch 500-675

J4=120W

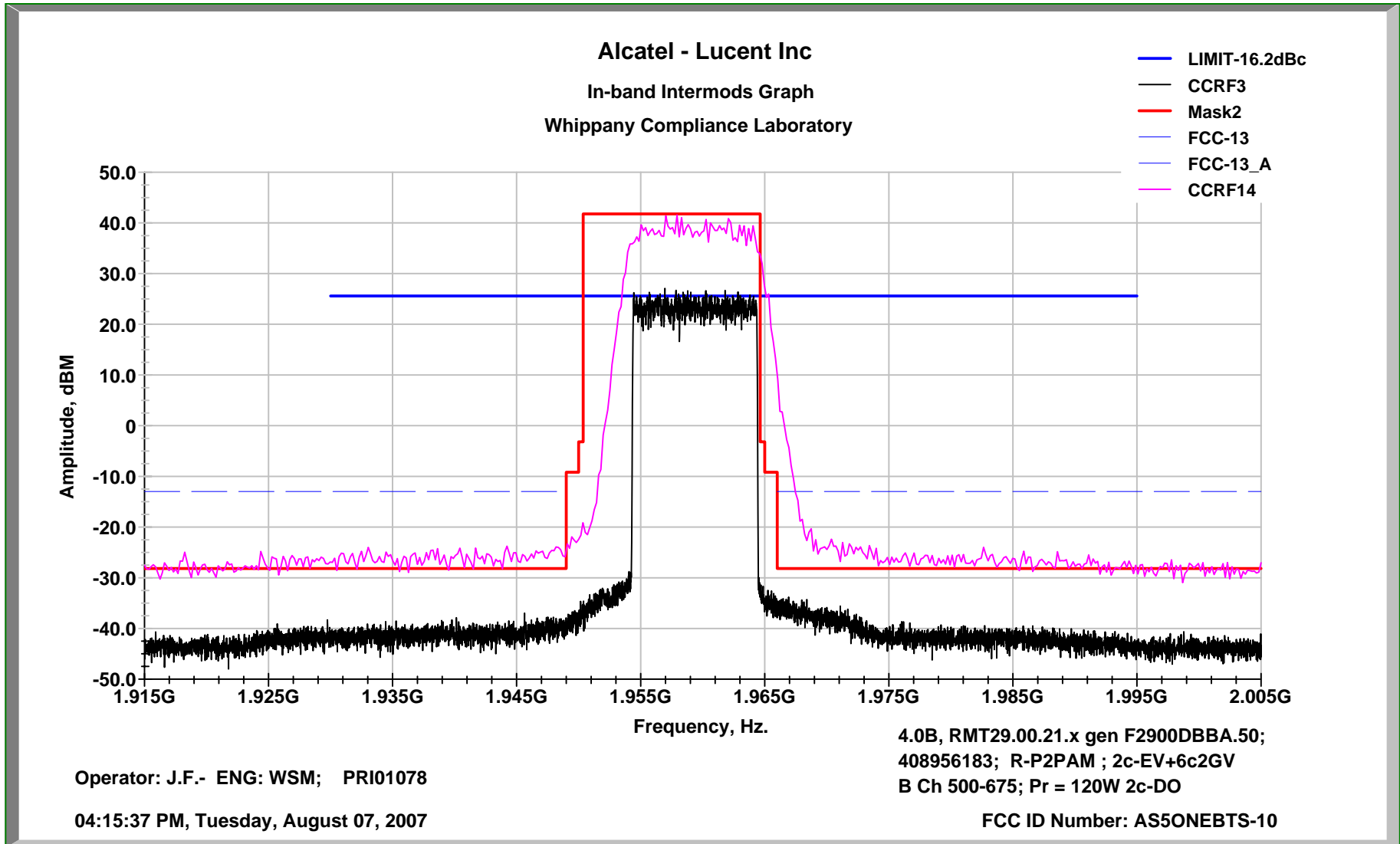

Occupied Bandwidth 8cx3A Block B-E Ch 600-775

J4=120W

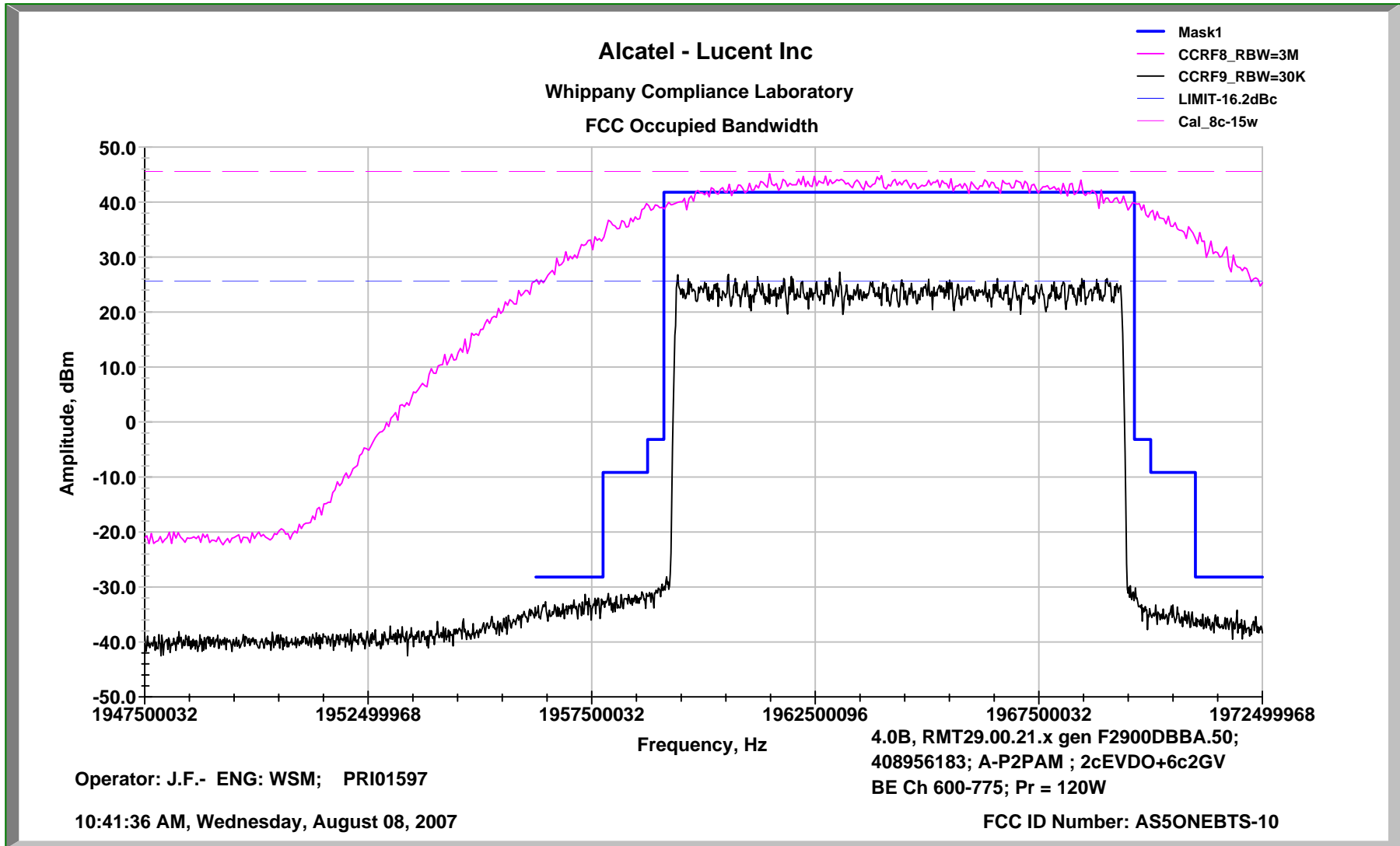



In-Band Intermods

8cx3A Block B-E Ch 600-775

J4=120W

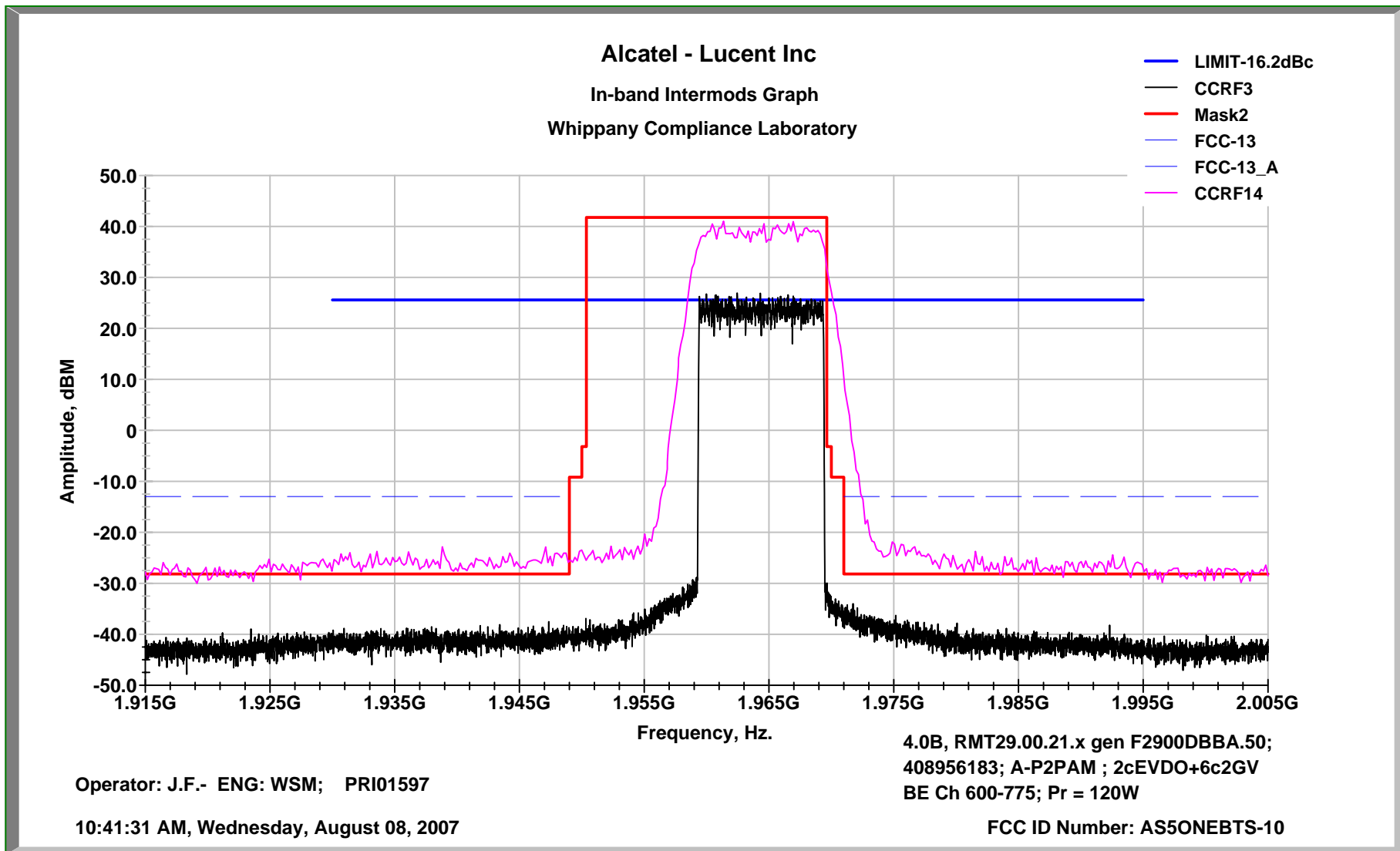

Occupied Bandwidth 8cx3A Block F-C Ch 825-1000

J4=120W

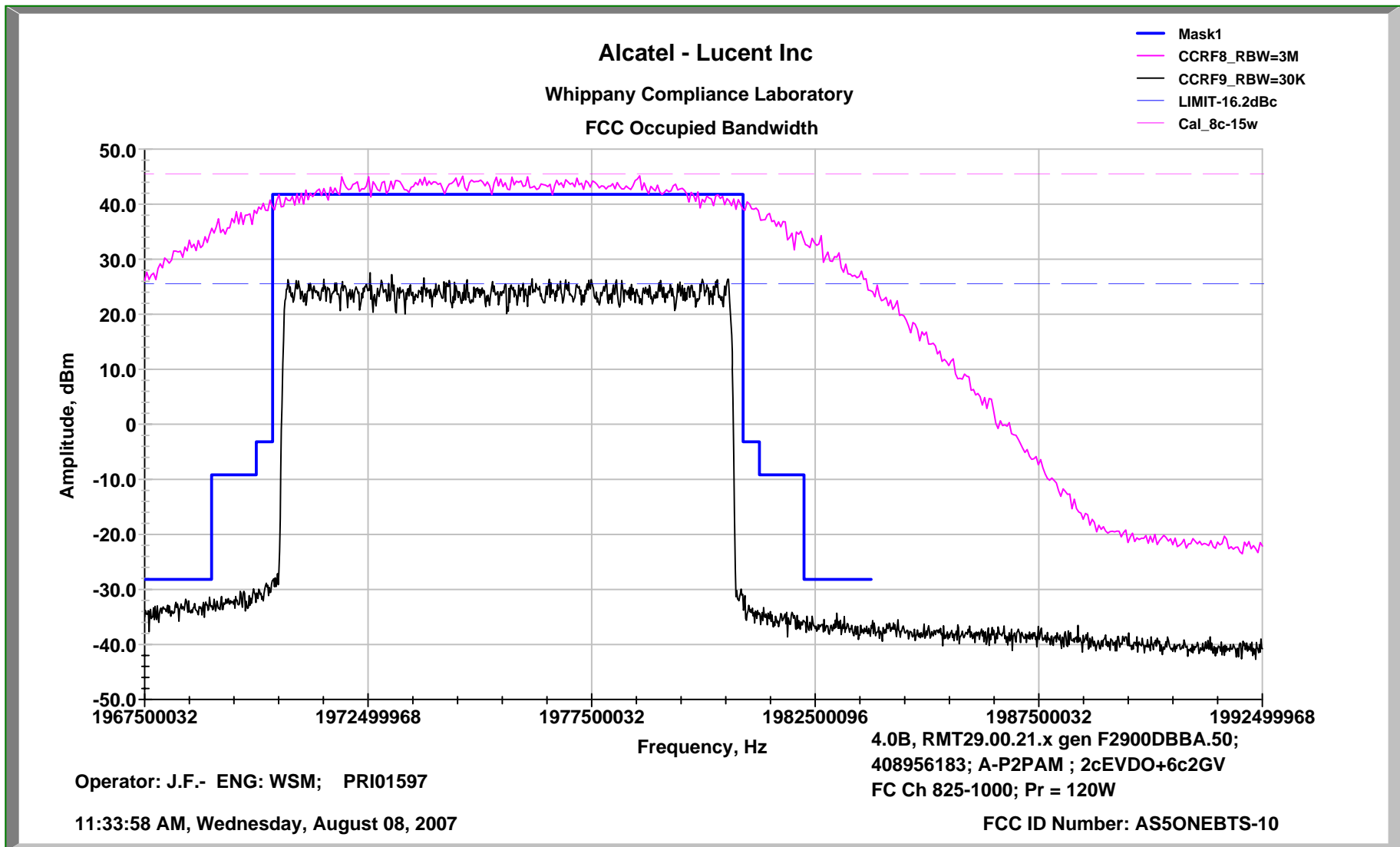

In-Band Intermods

8cx3A Block F-C Ch 825-1000

J4=120W

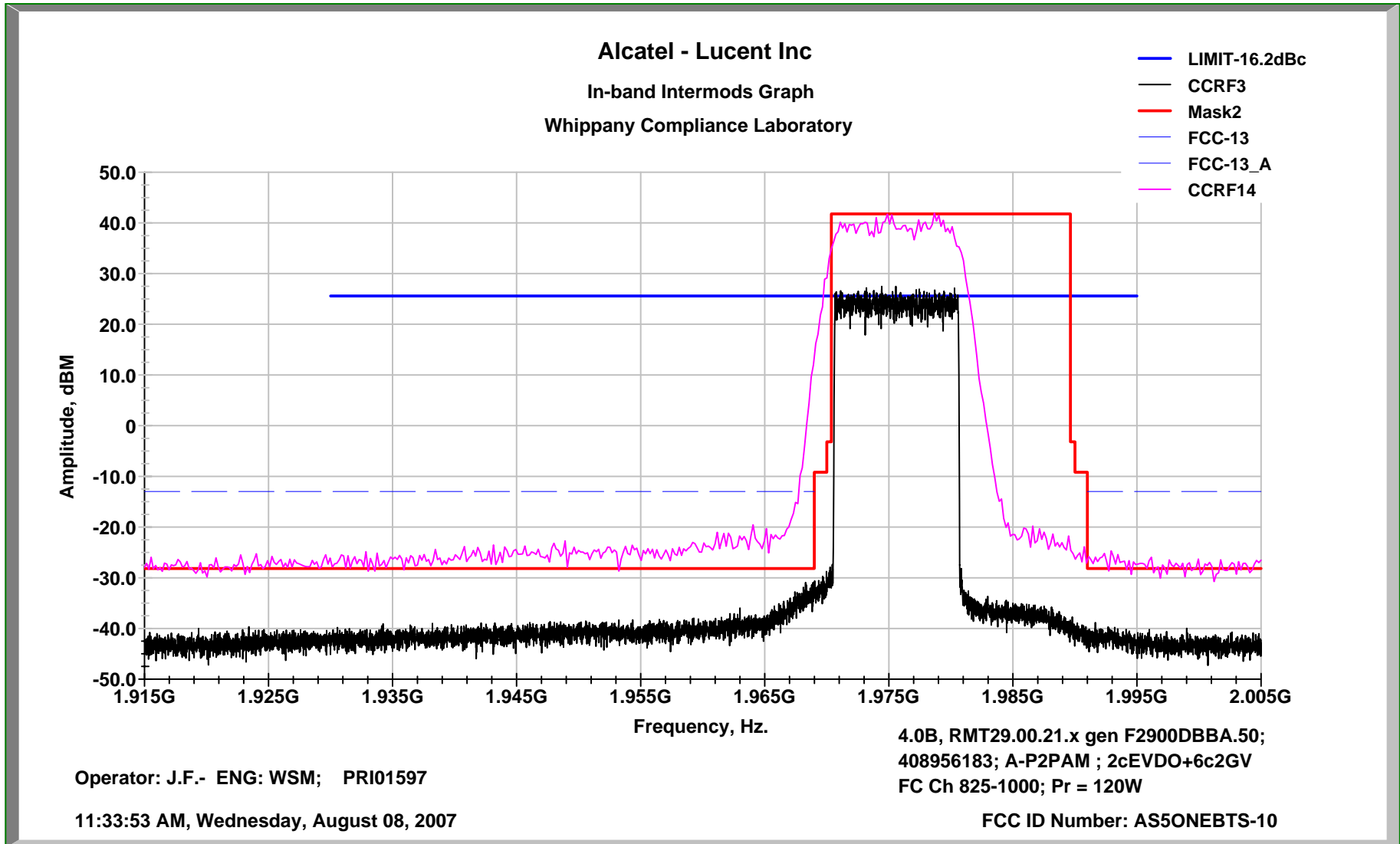

Occupied Bandwidth 8cx3A Block C1 Ch 925-1100

J4=120W

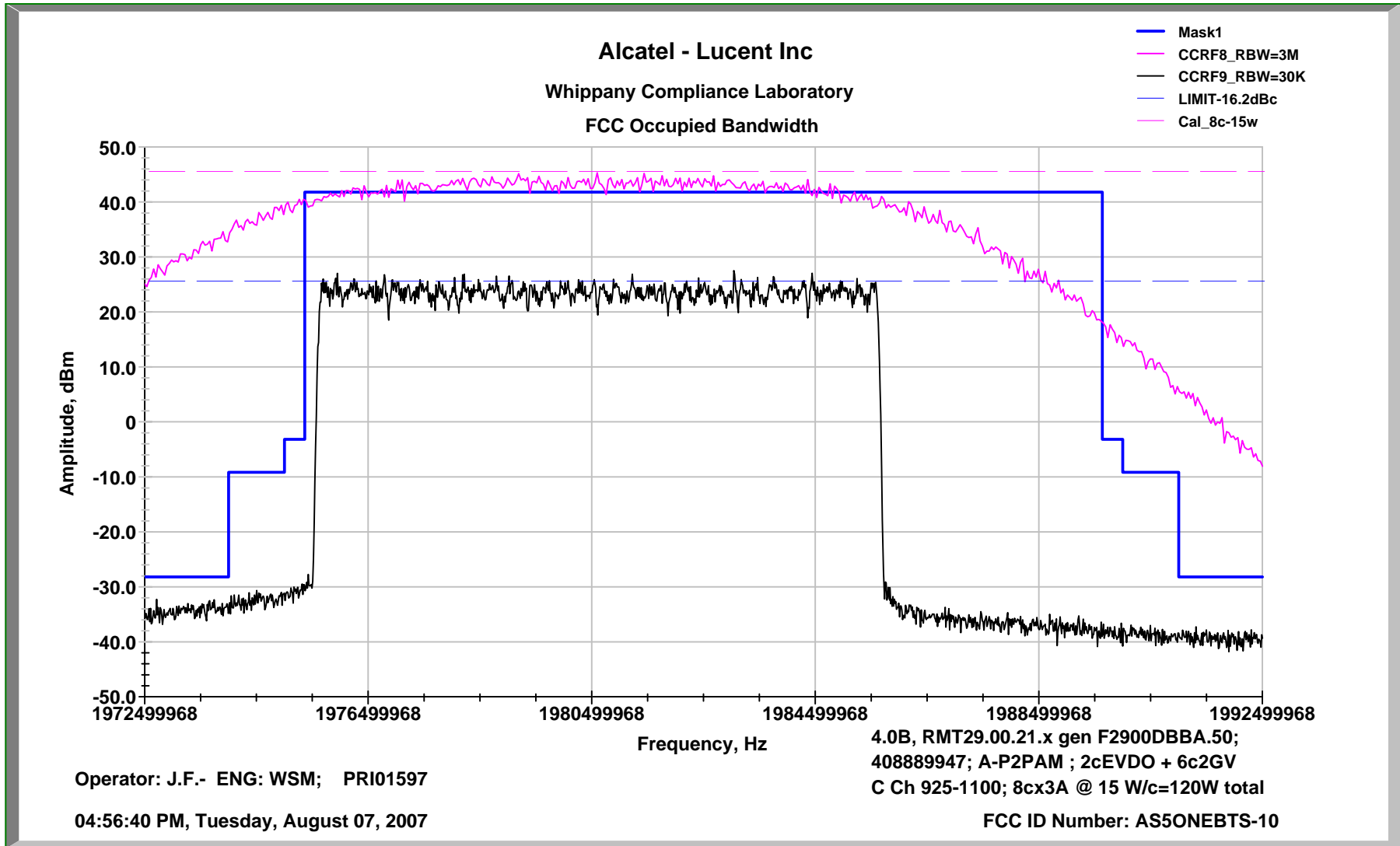

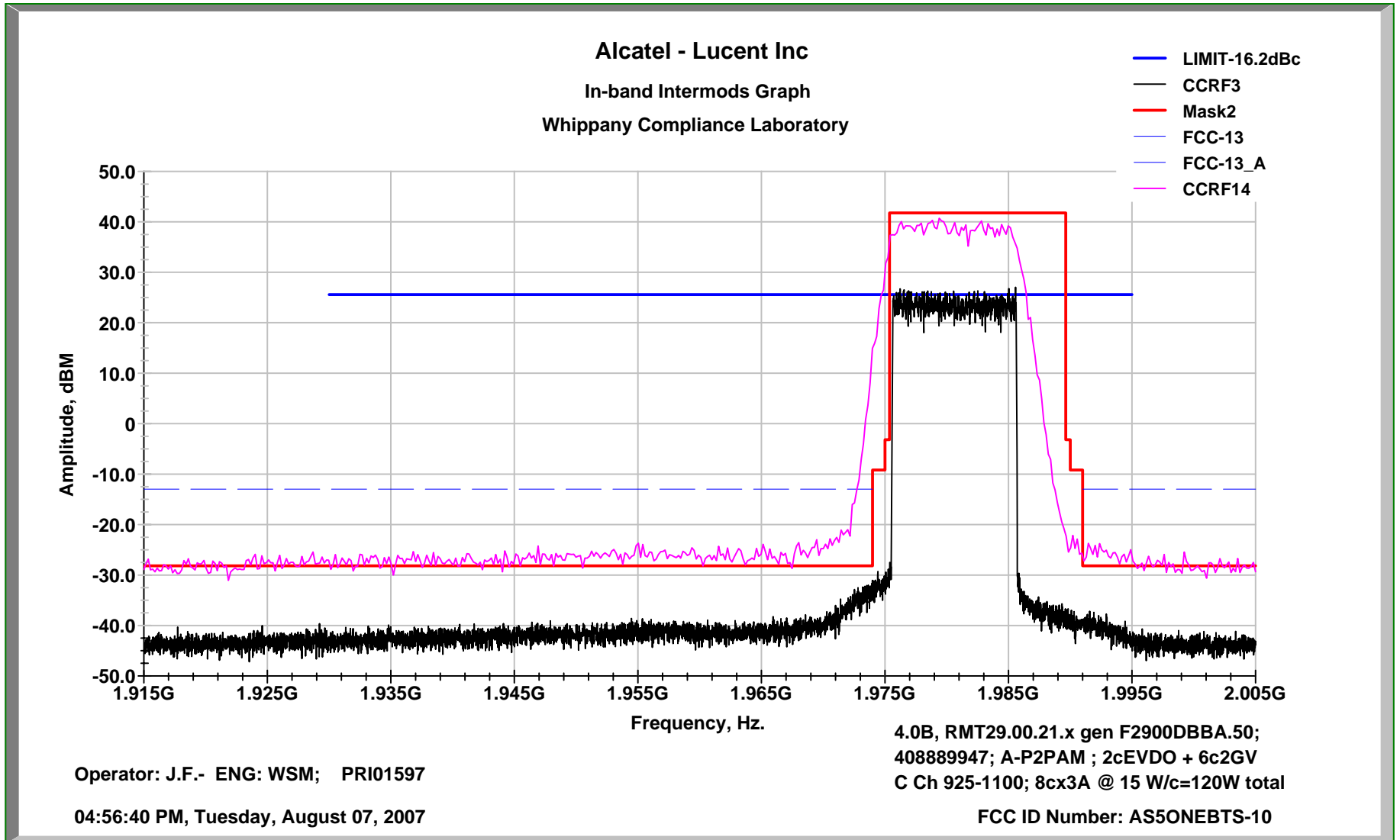

Occupied Bandwidth 8cx3A Block C1 Ch 1000-1175

J4=120W

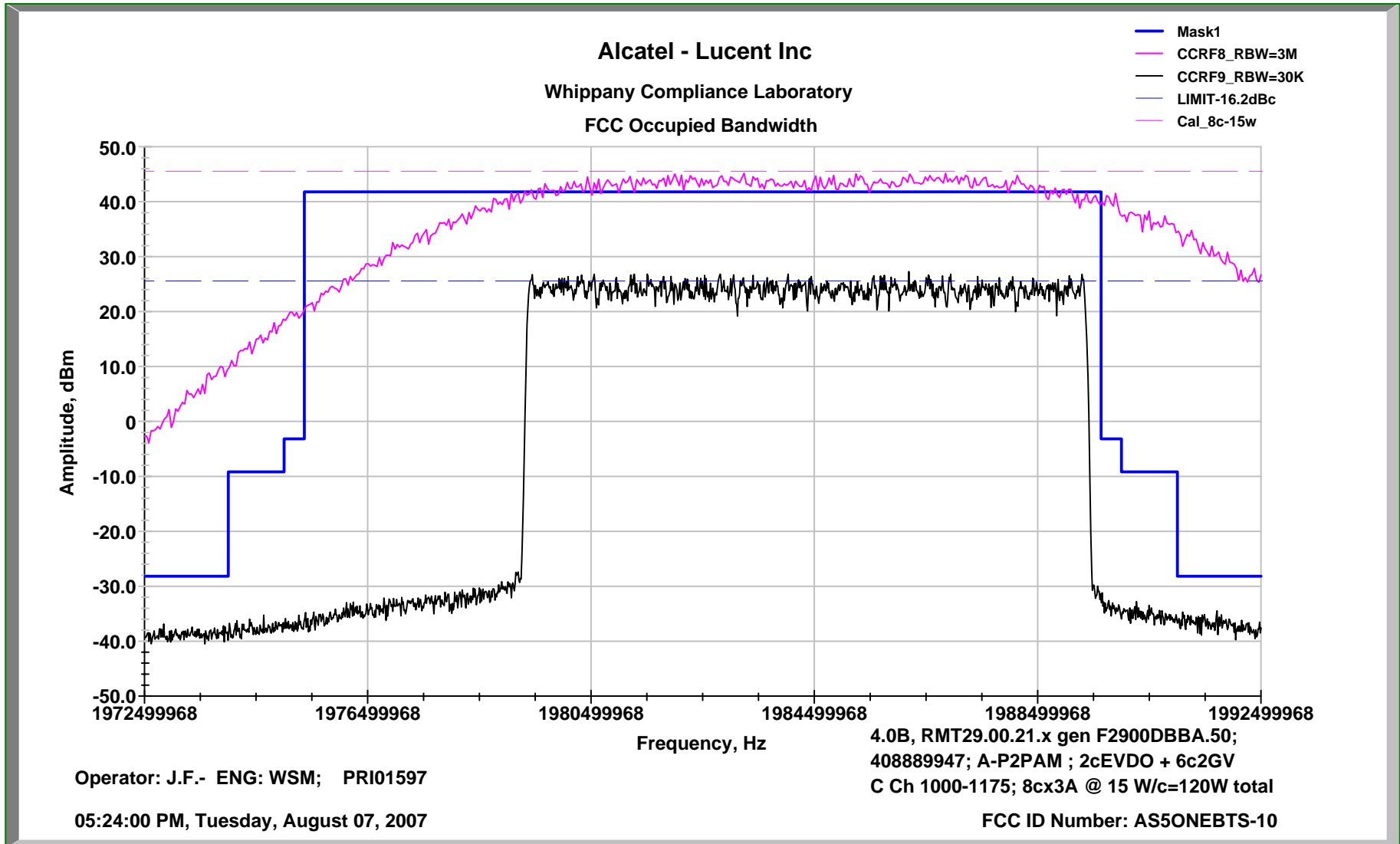

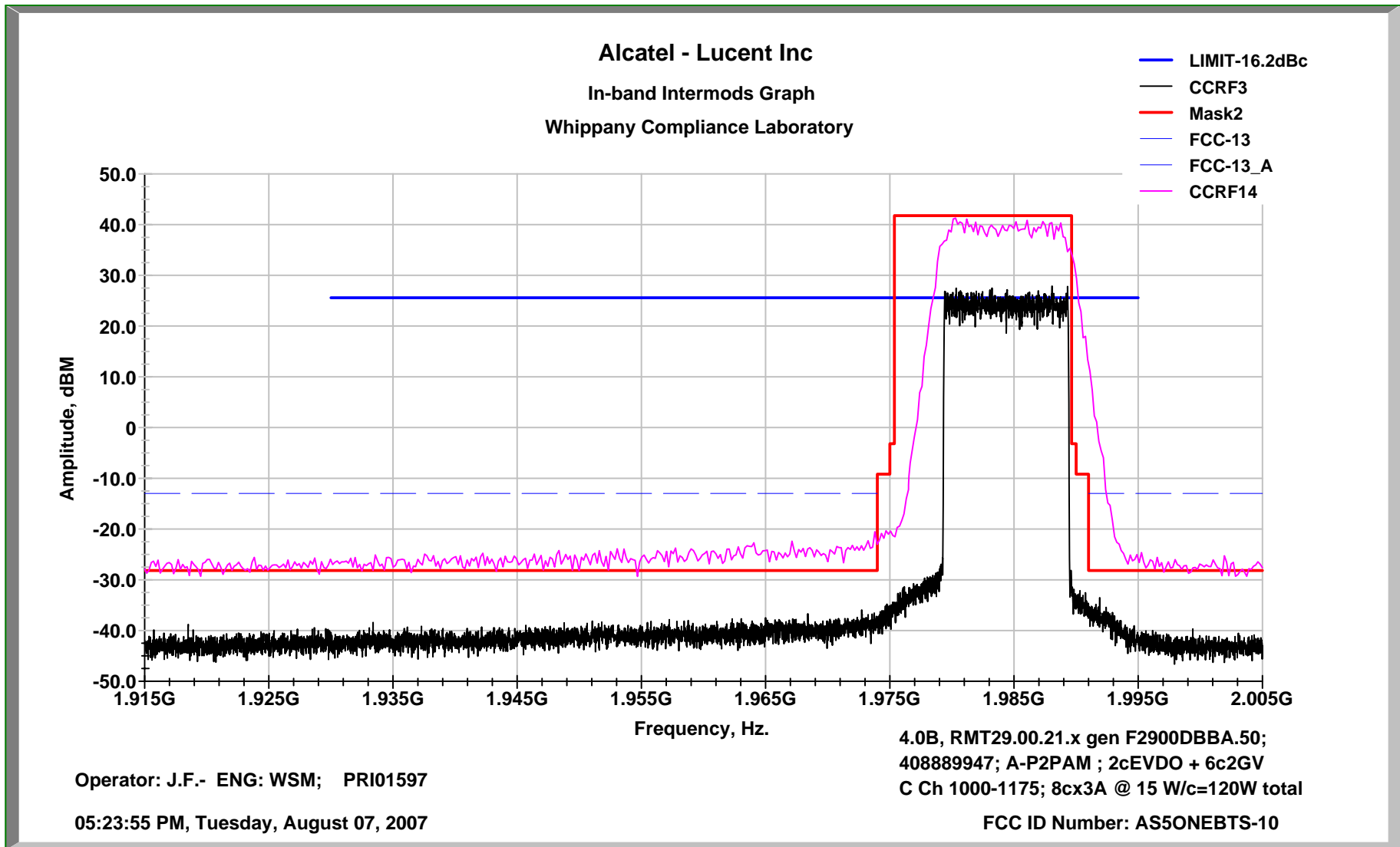

Occupied Bandwidth 8cx3A Block C-G Ch 1100-1275

J4=120W

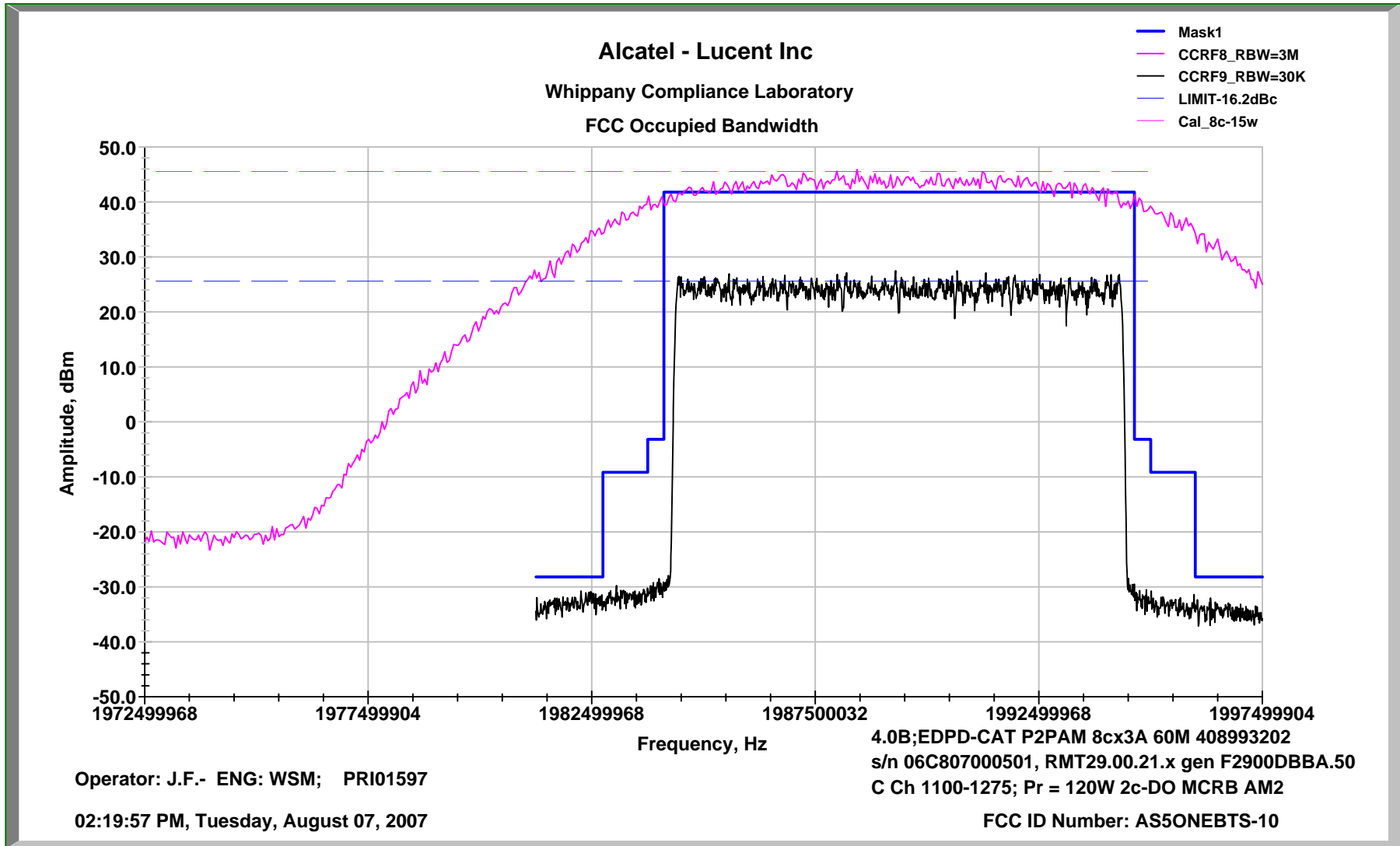



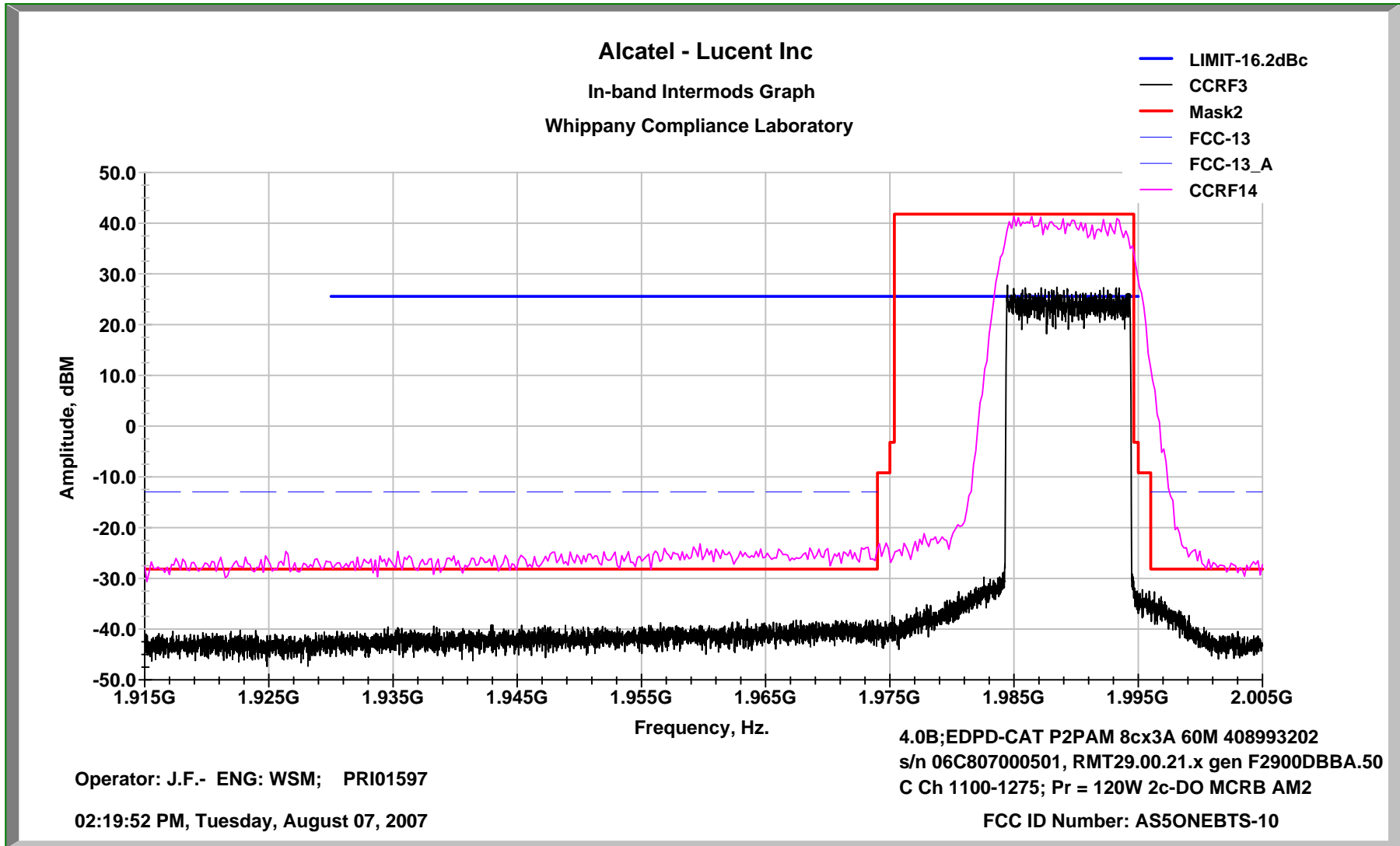

# Occupied Bandwidth Test Report AS5ONEBTS-10

7c at 17.1 W/carrier, 120 Watts Total  
using  
3x P2PAMs

Occupied Bandwidth 7cx3A 17.14W/c 2c-DO

Block A1 Ch 25-175

Andrew Amplifiers

J4=120W

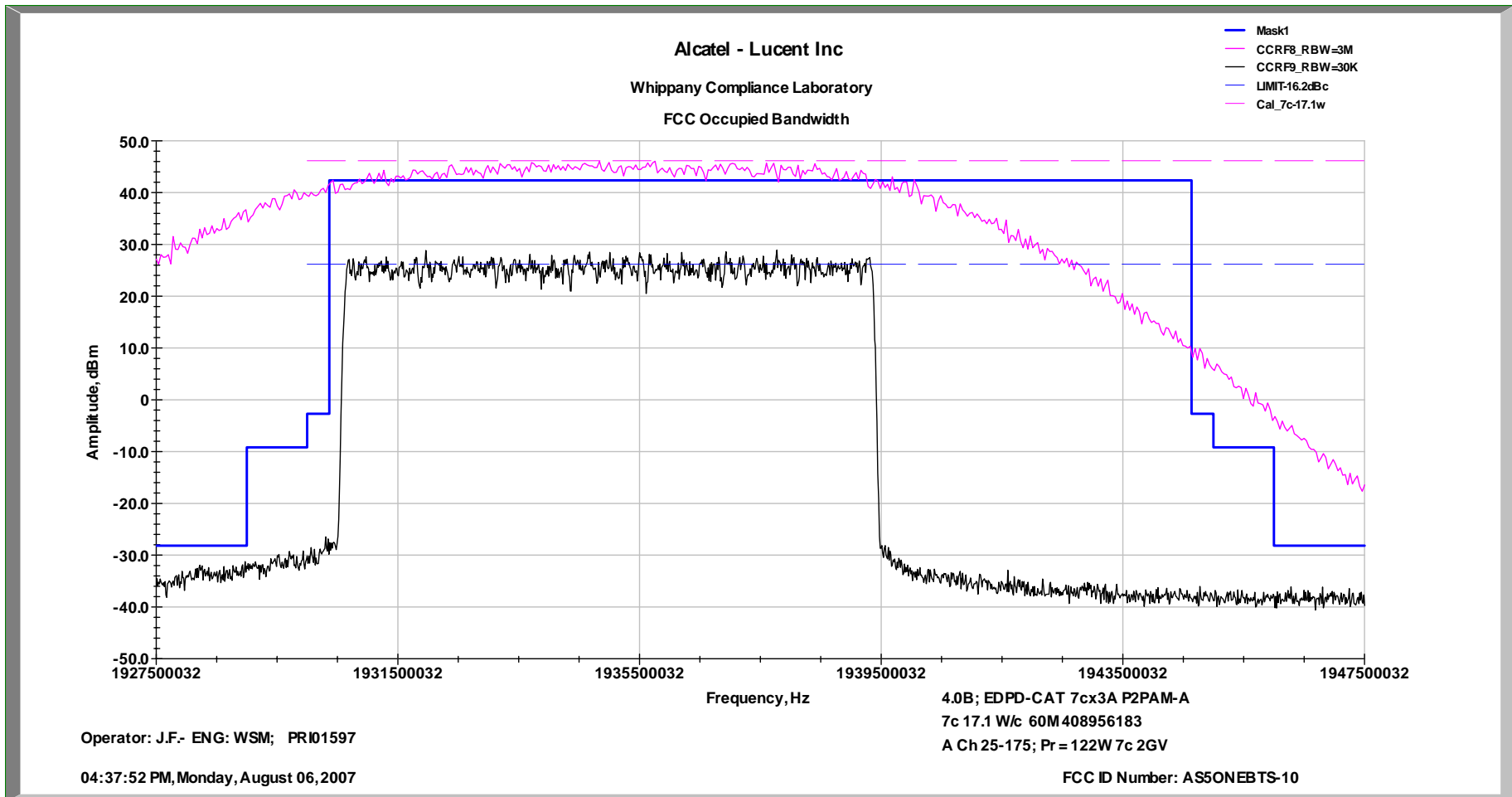

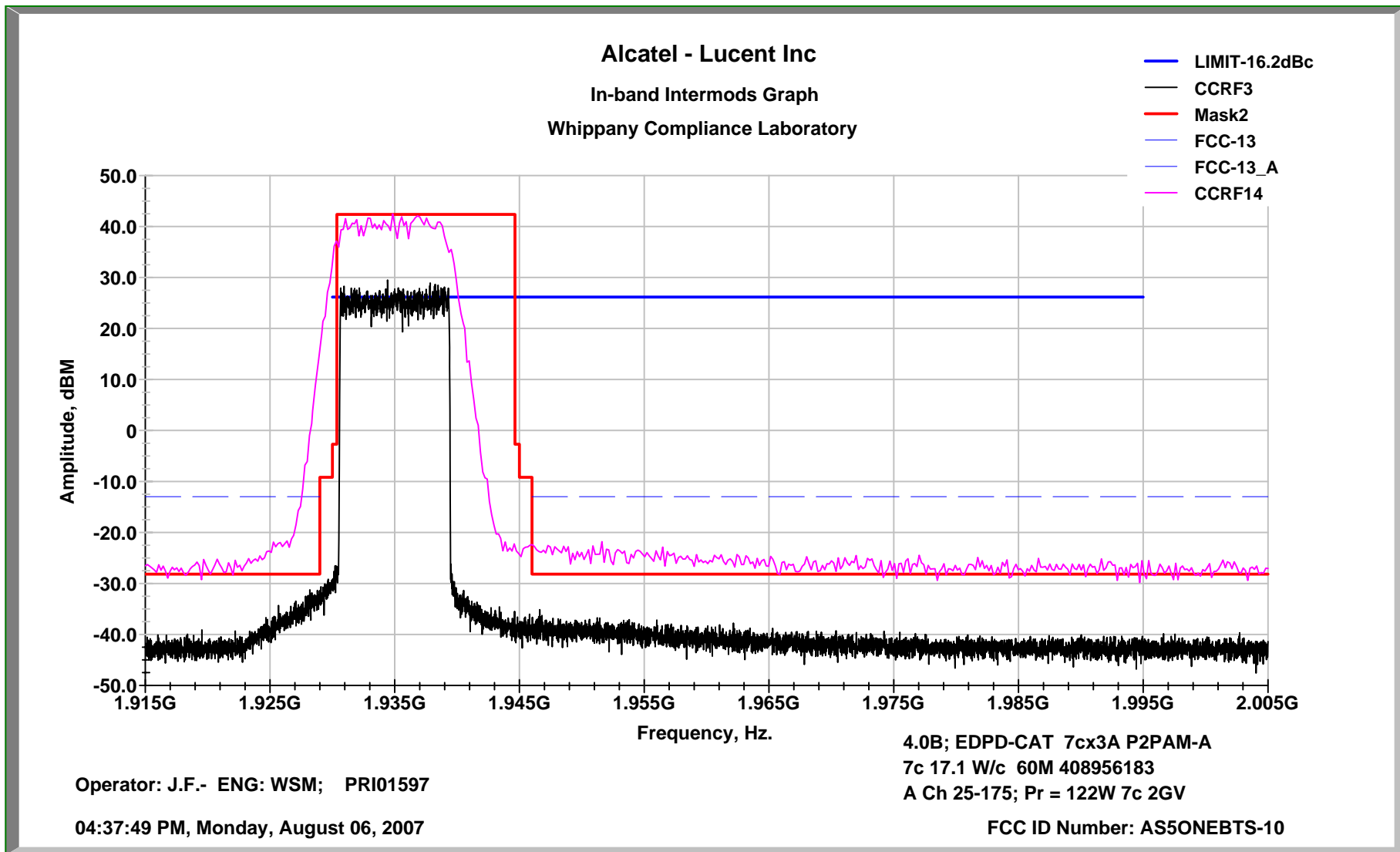

Occupied Bandwidth 7cx3A Block A5 Ch 125-275

J4=120W

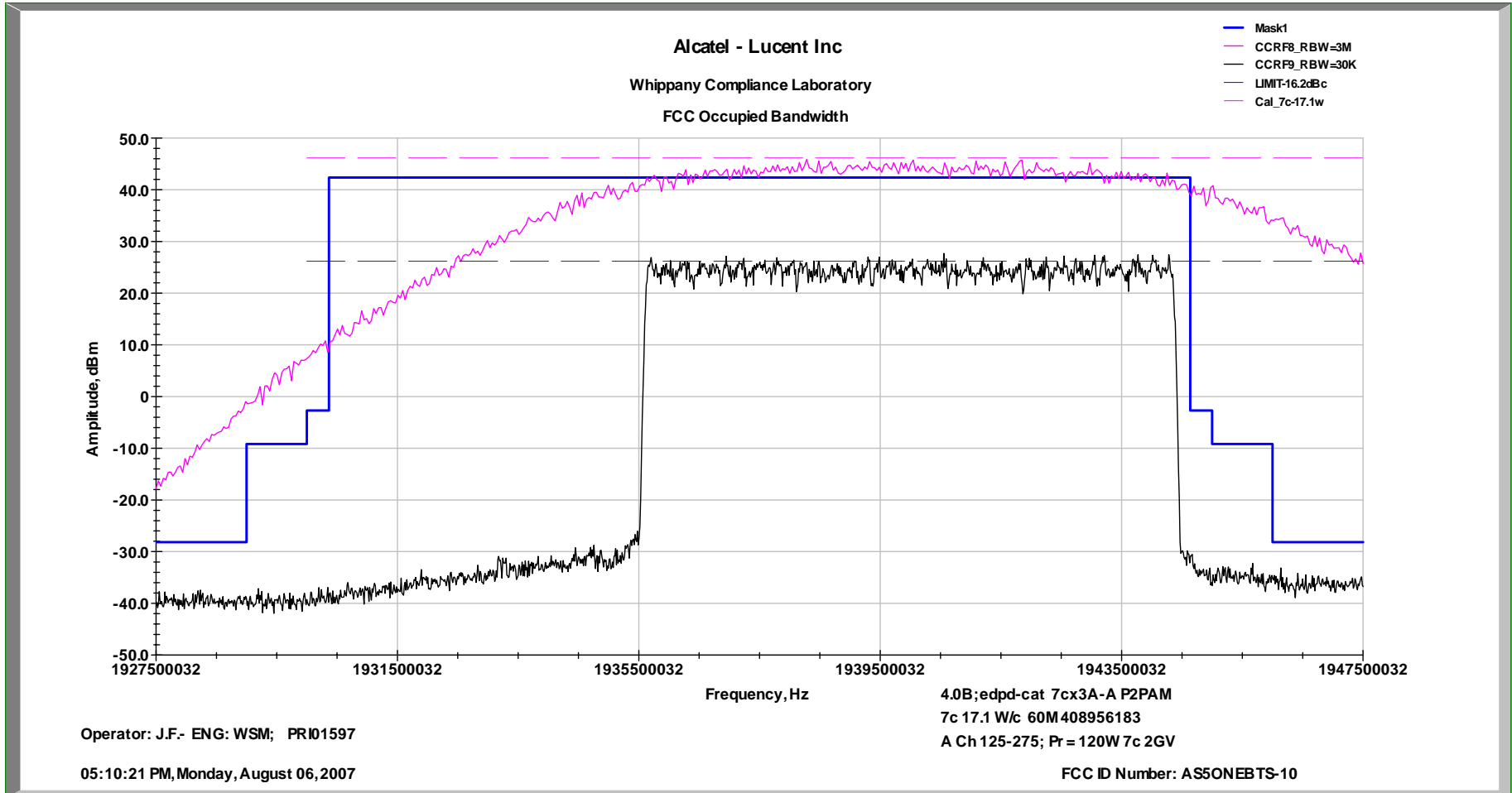

In-Band Intermods

7cx3A Block A5 Ch 125-275

J4=120W

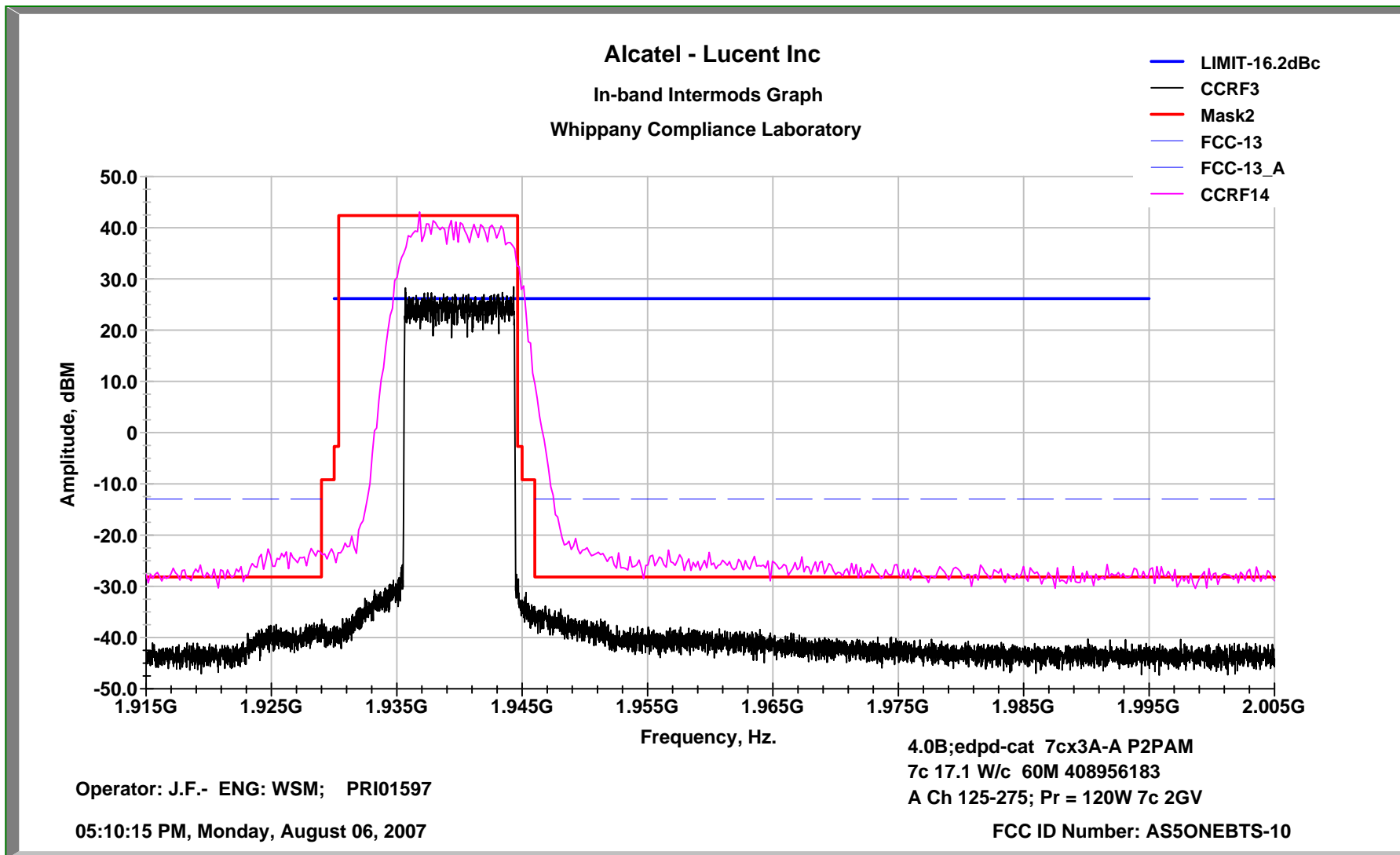

Occupied Bandwidth 7cx3A Block AD Ch 225-375

J4=120W

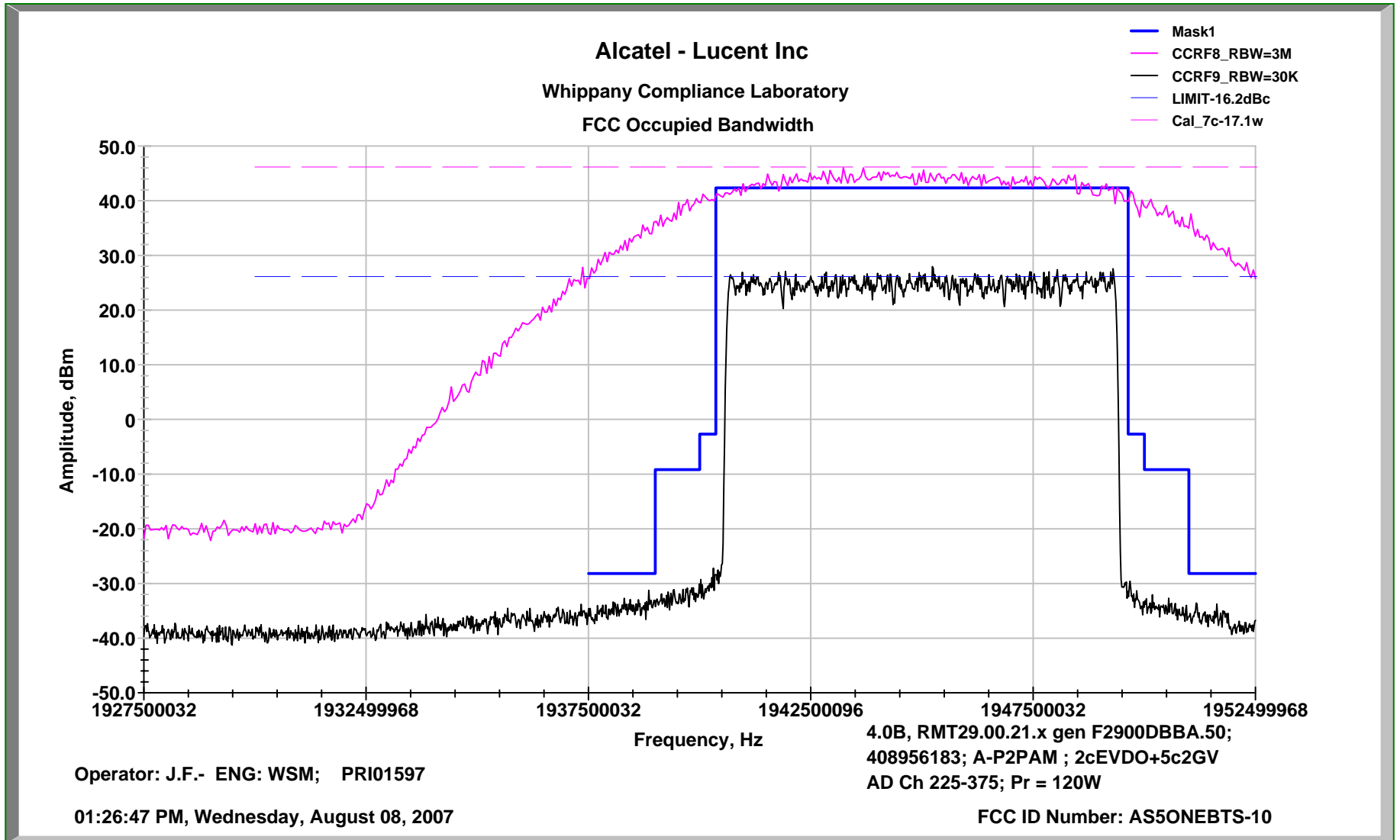

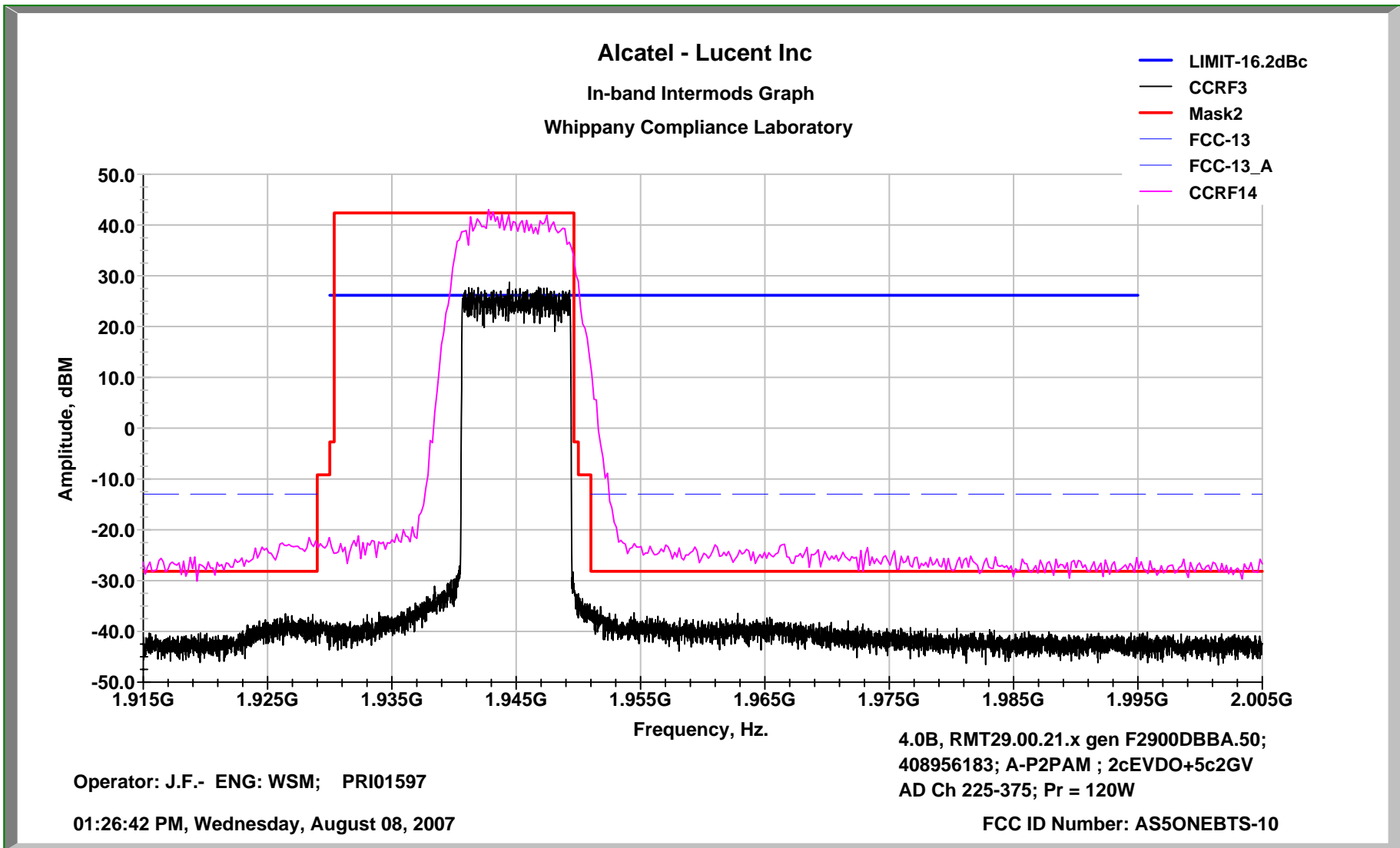



Occupied Bandwidth 7cx3A Block B1 Ch 425-575

J4=120W

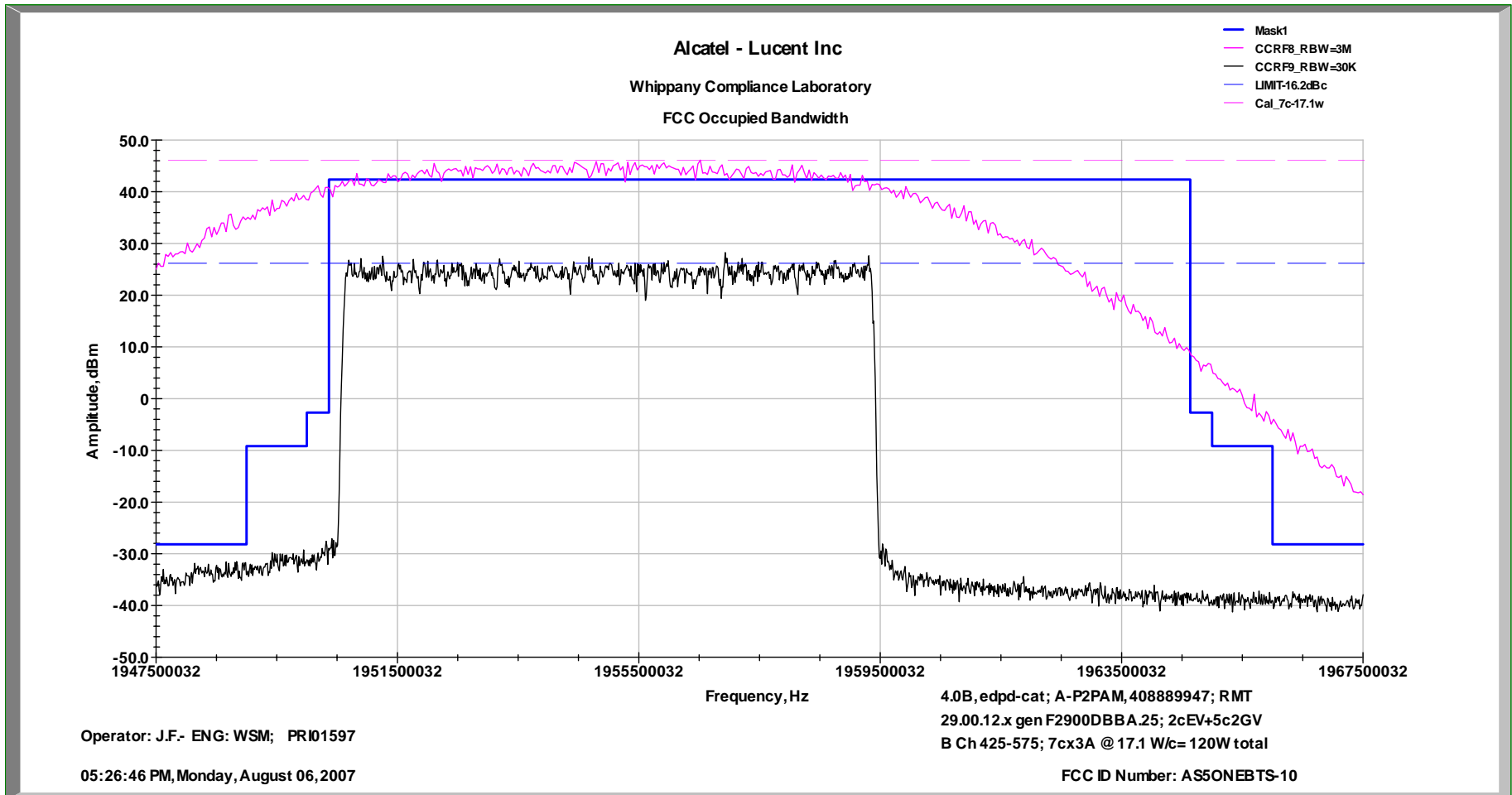

In-Band Intermods

7cx3A Block B1 Ch 425-575

J4=120W

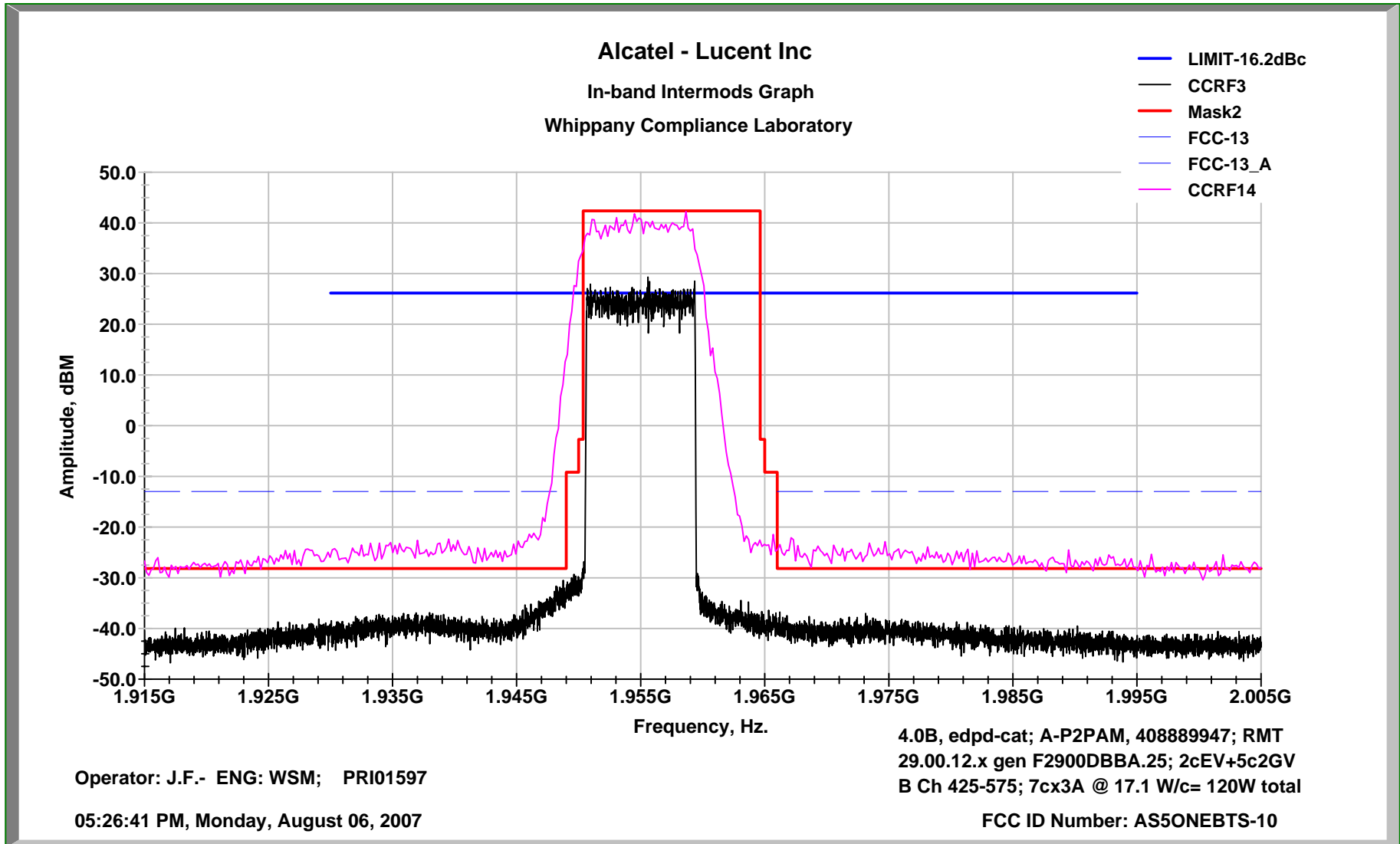

Occupied Bandwidth 7cx3A Block B5 Ch 525-675

J4=120W

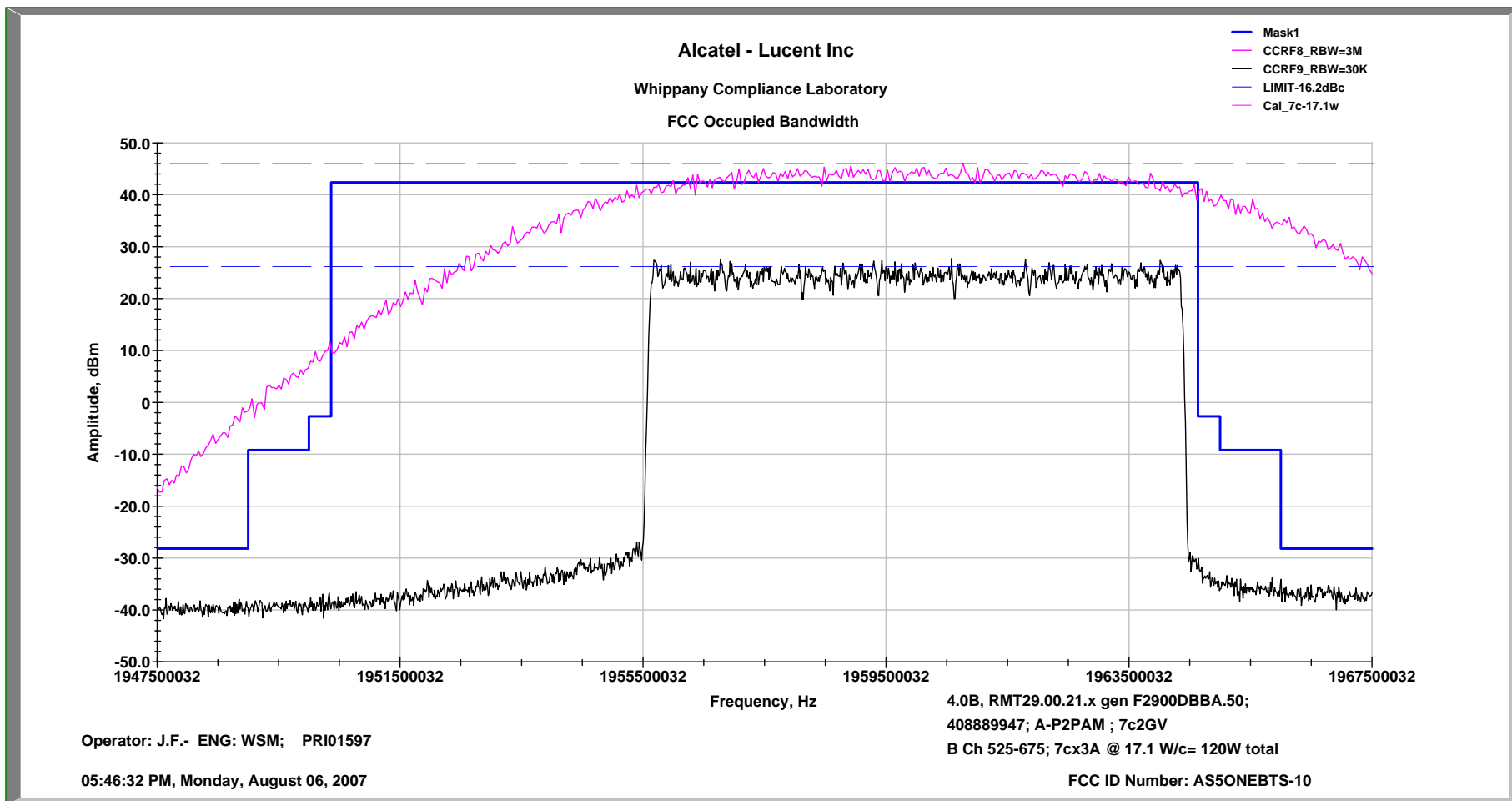

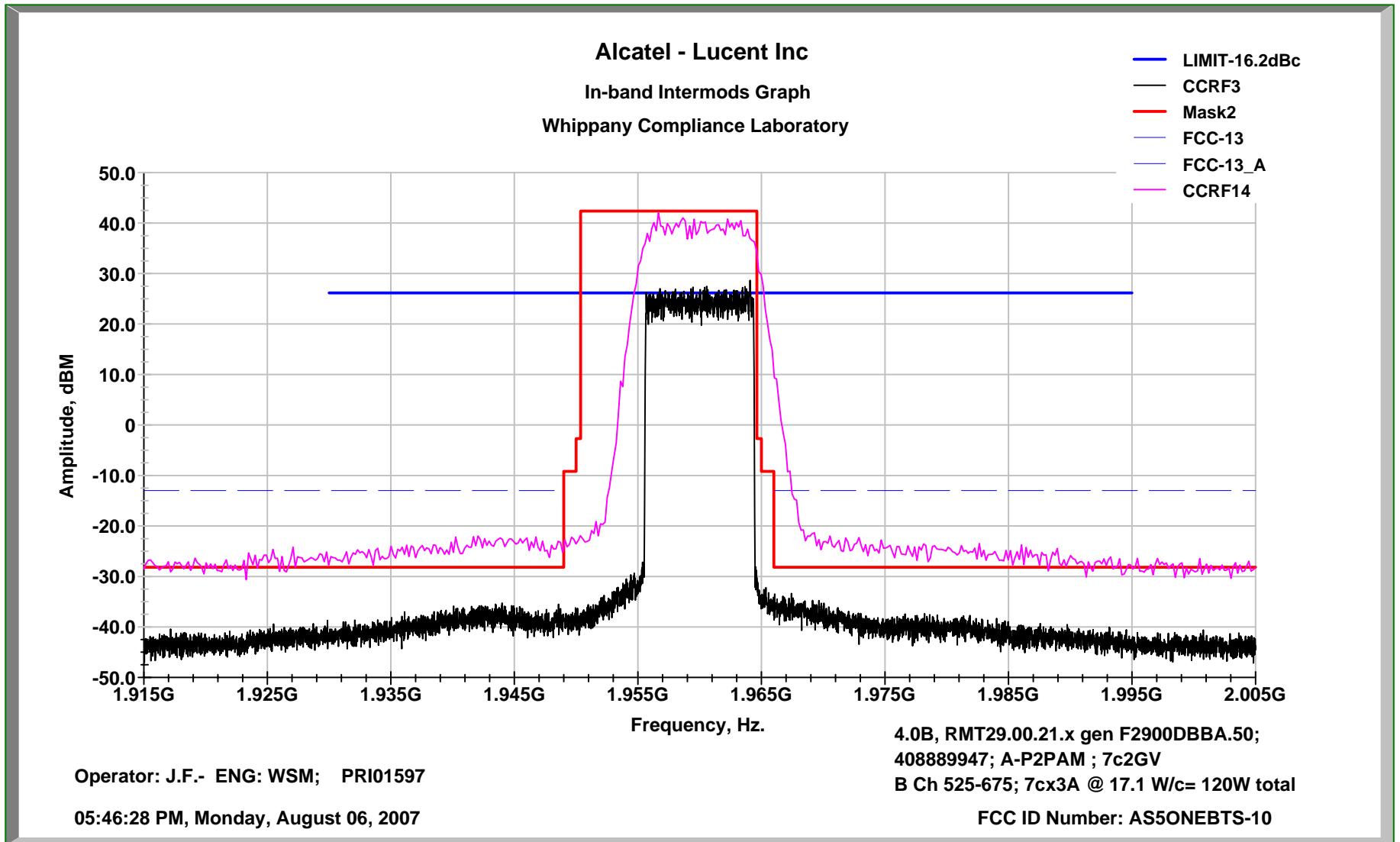

Occupied Bandwidth 7cx3A Block B-E Ch 625-775

J4=120W

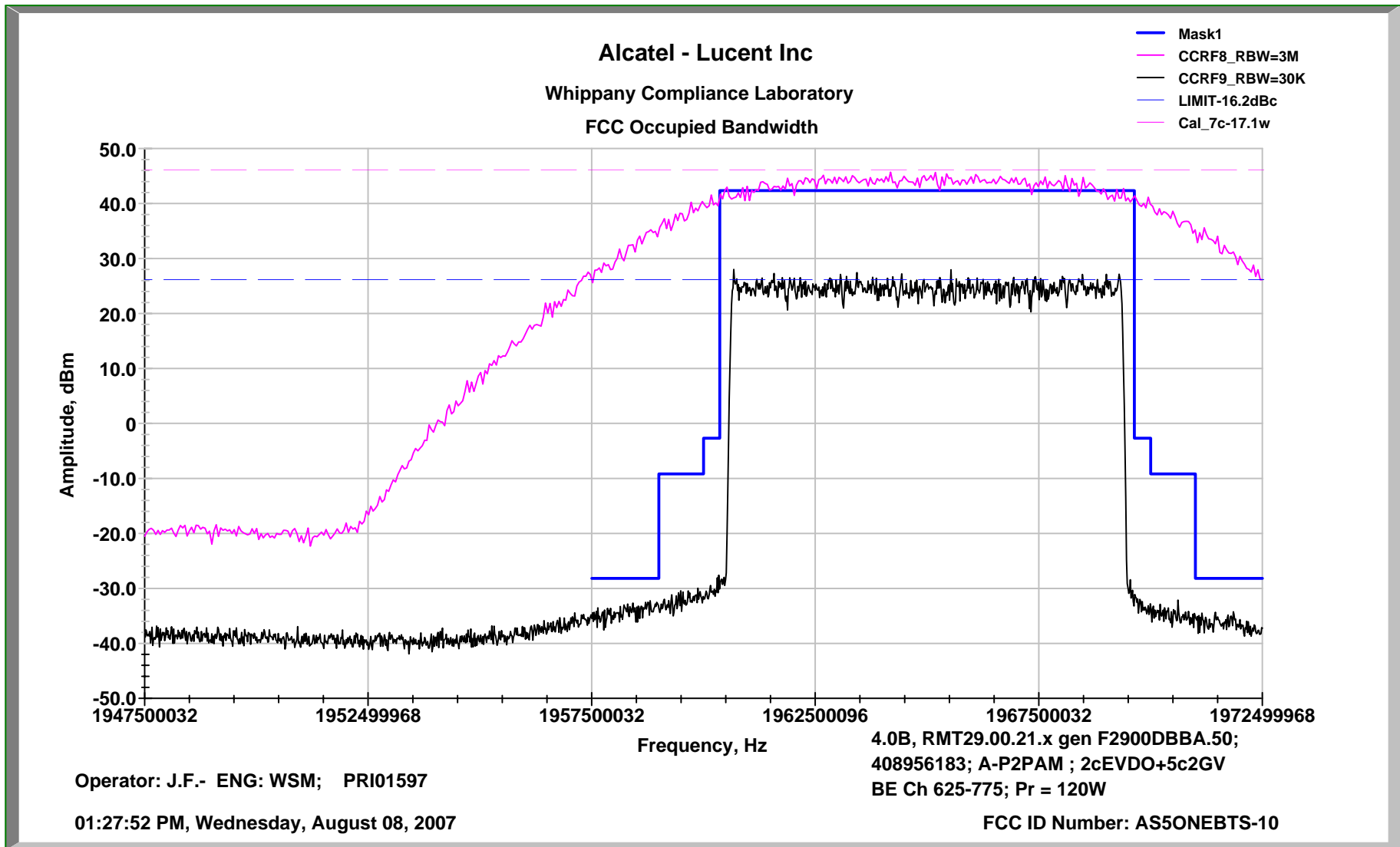

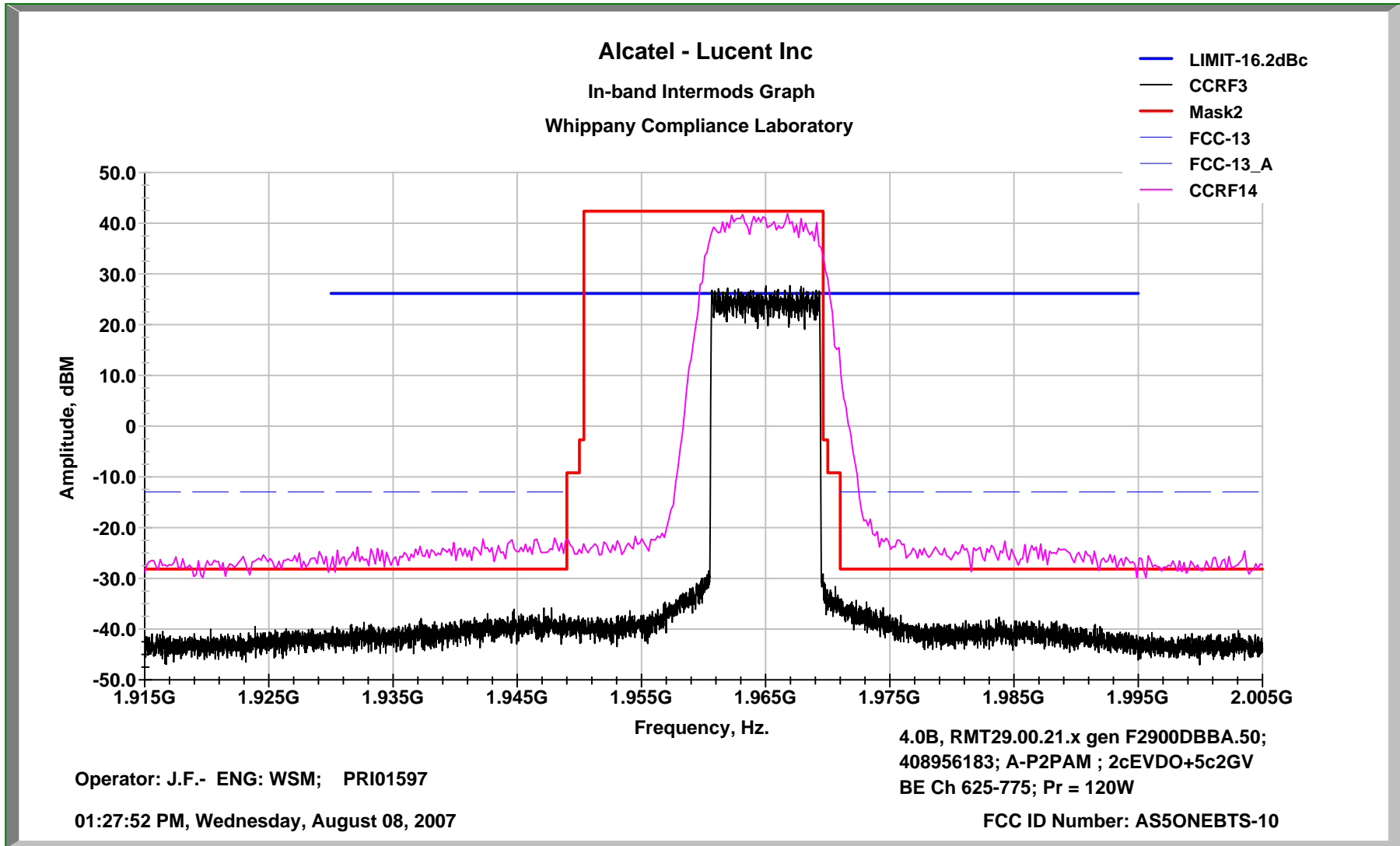

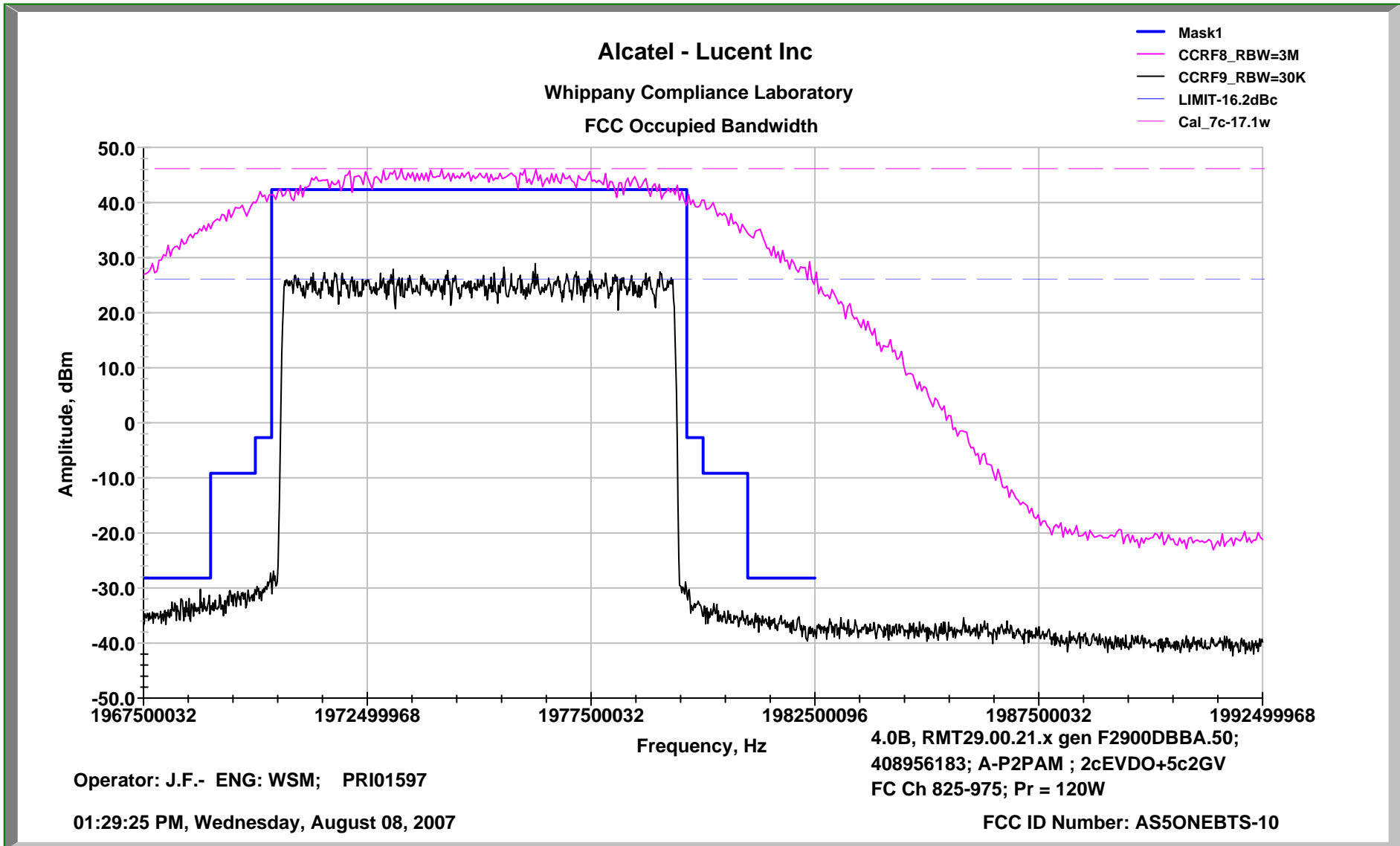

In-Band Intermods

7cx3A Block FC Ch 825-975 (2c EVDO + 5c 2GV

J4=120W

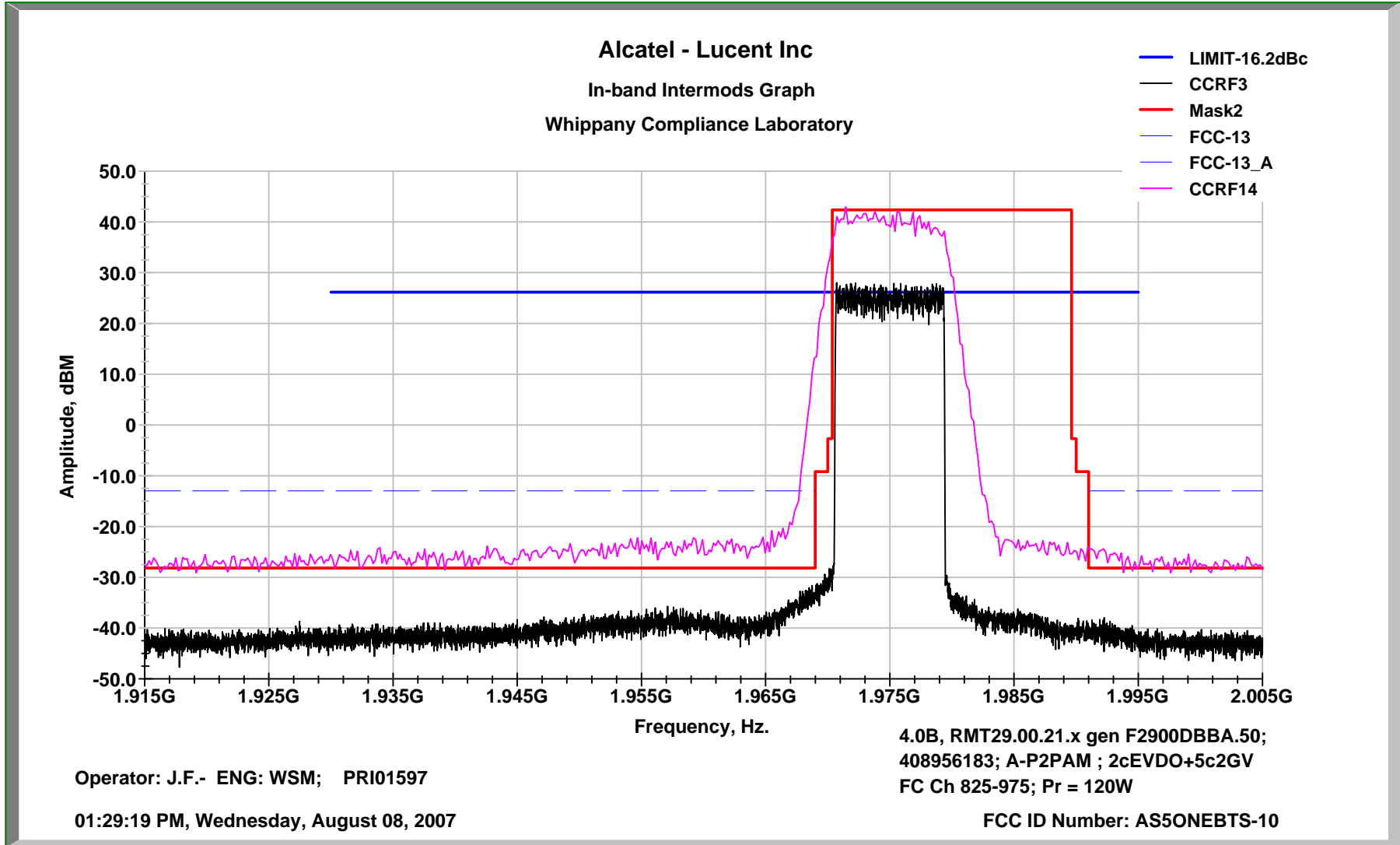



Occupied Bandwidth 7cx3A Block C1 Ch 925-1075

J4=120W

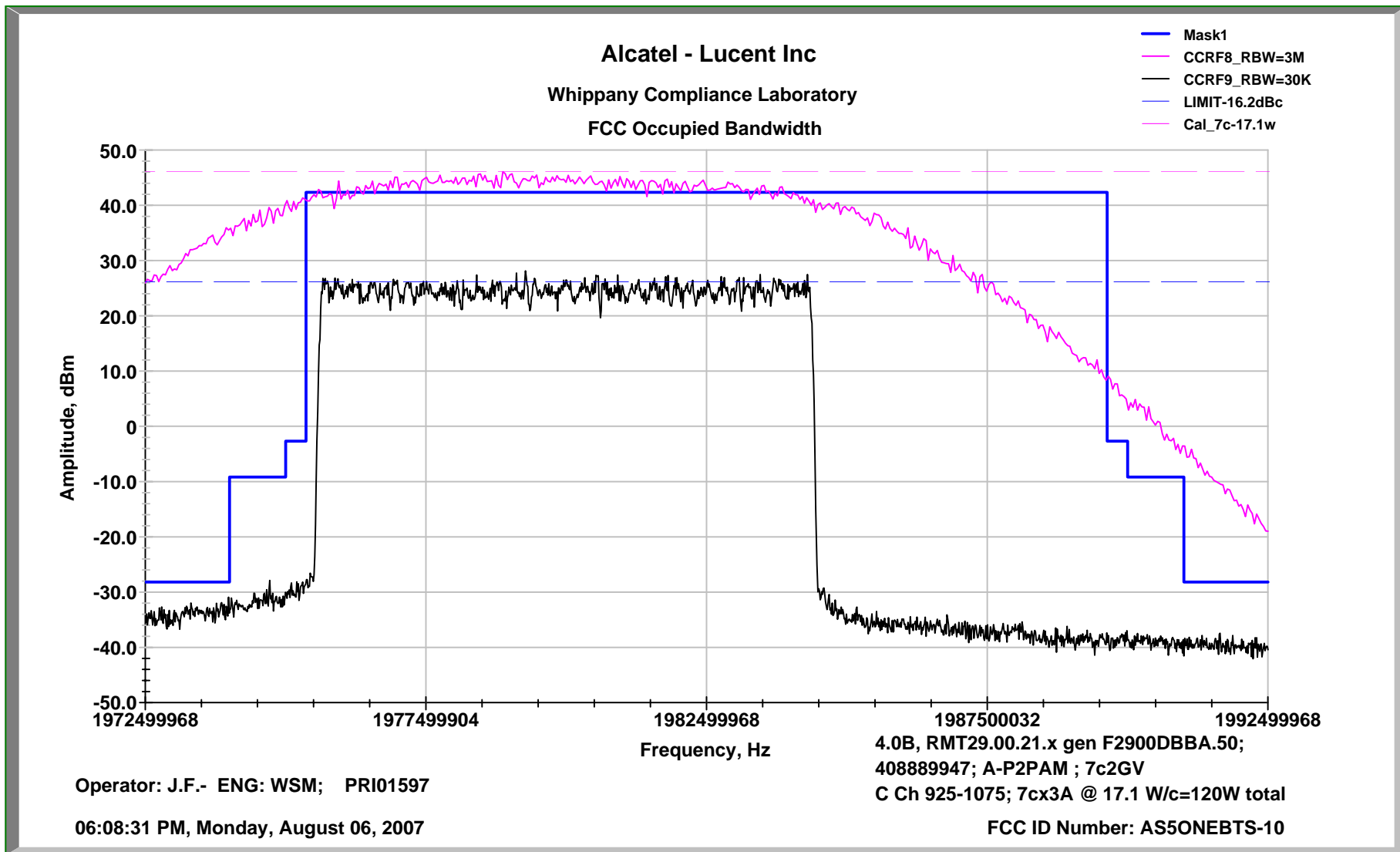

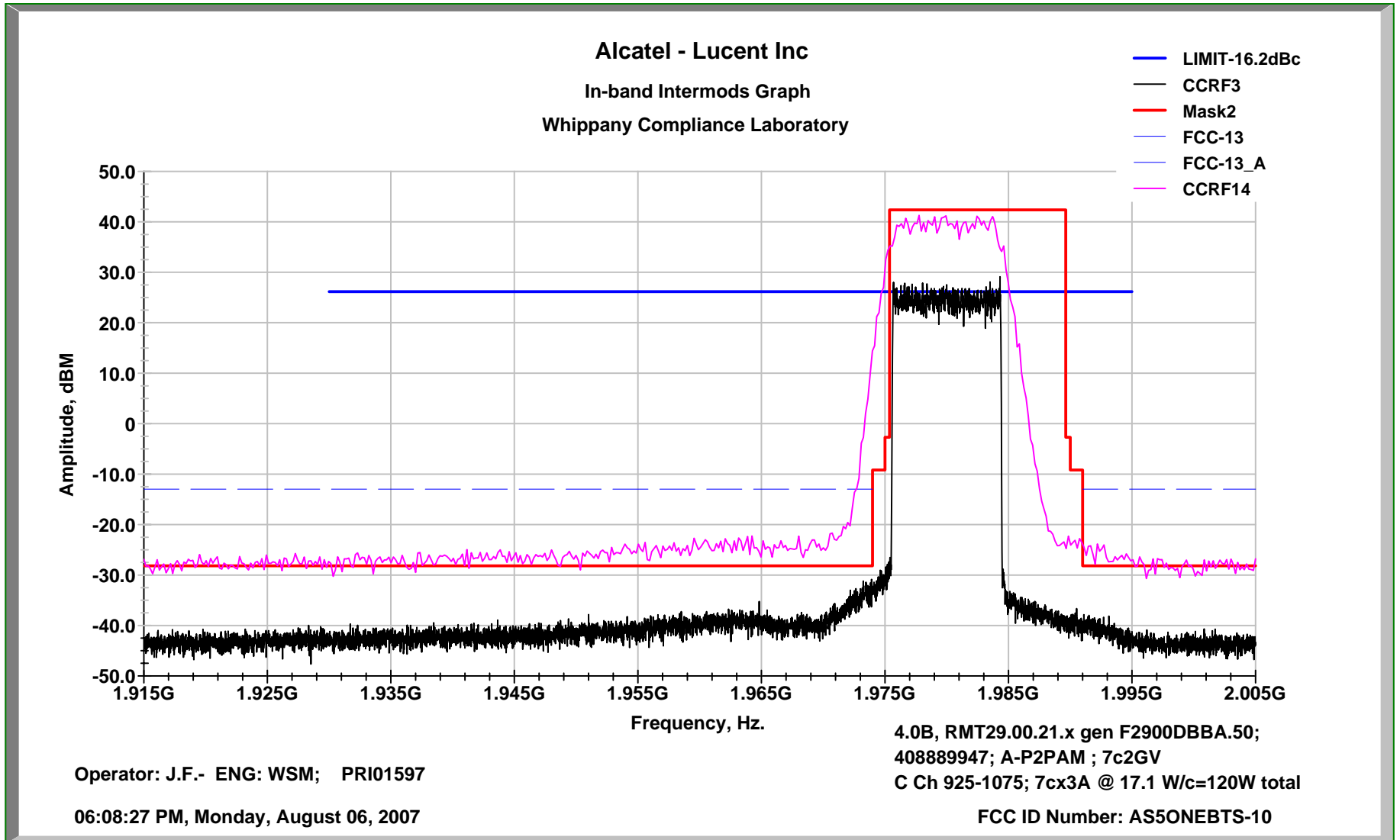

Occupied Bandwidth 7cx3A Block C5 Ch 1025-1175

J4=120W

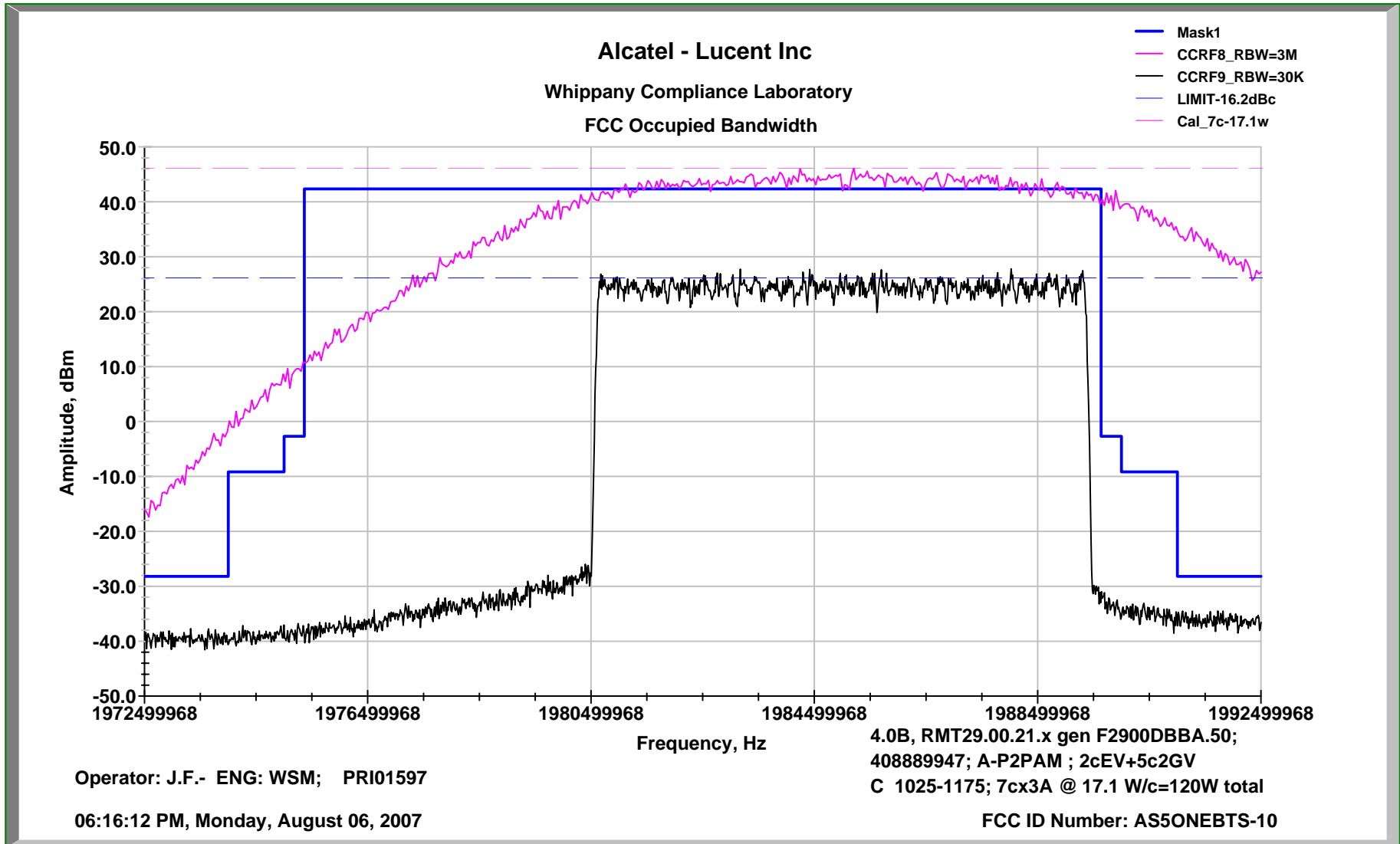

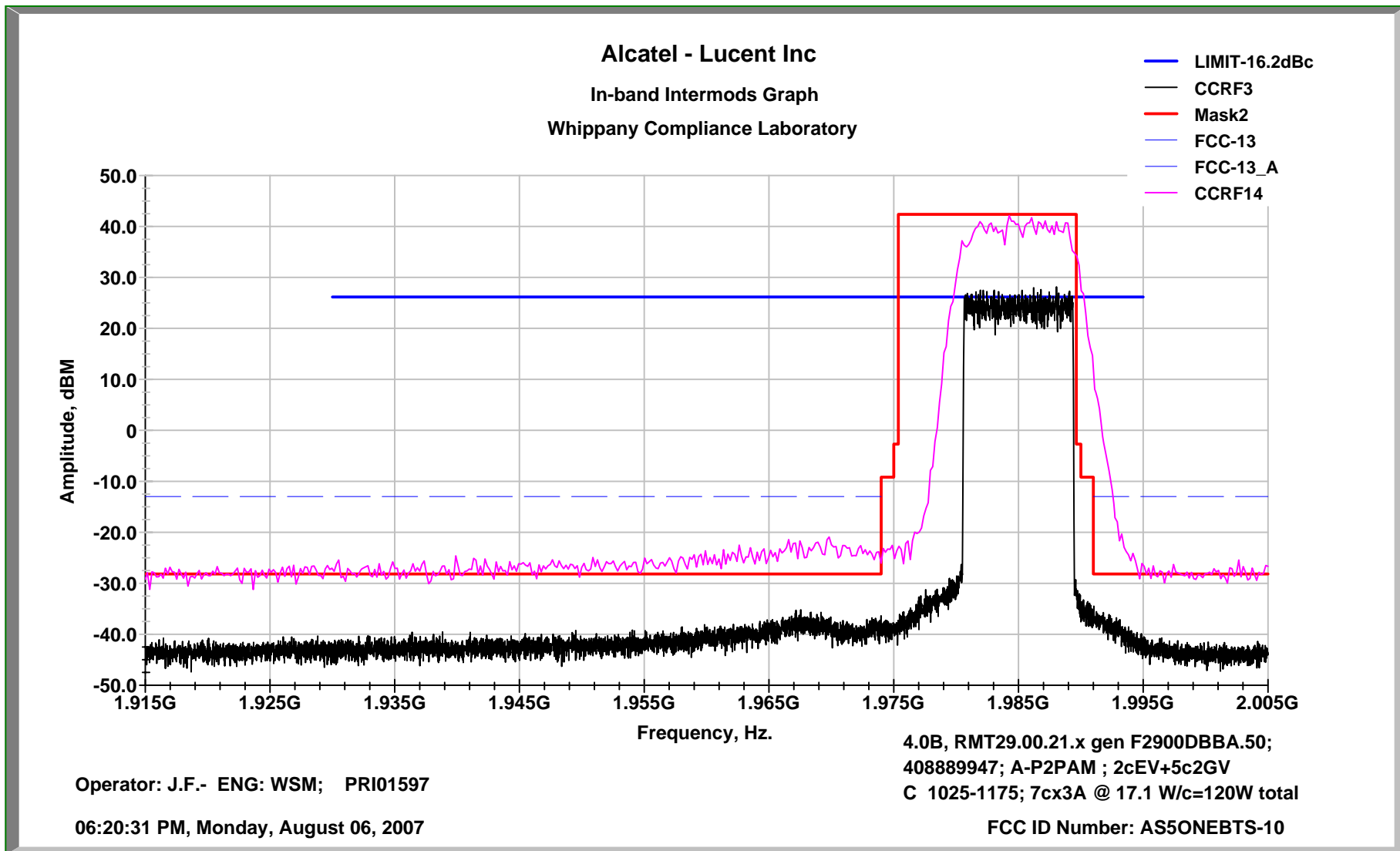

Occupied Bandwidth 7cx3A Blocks C-G Ch 1125, 1275

J4=120W

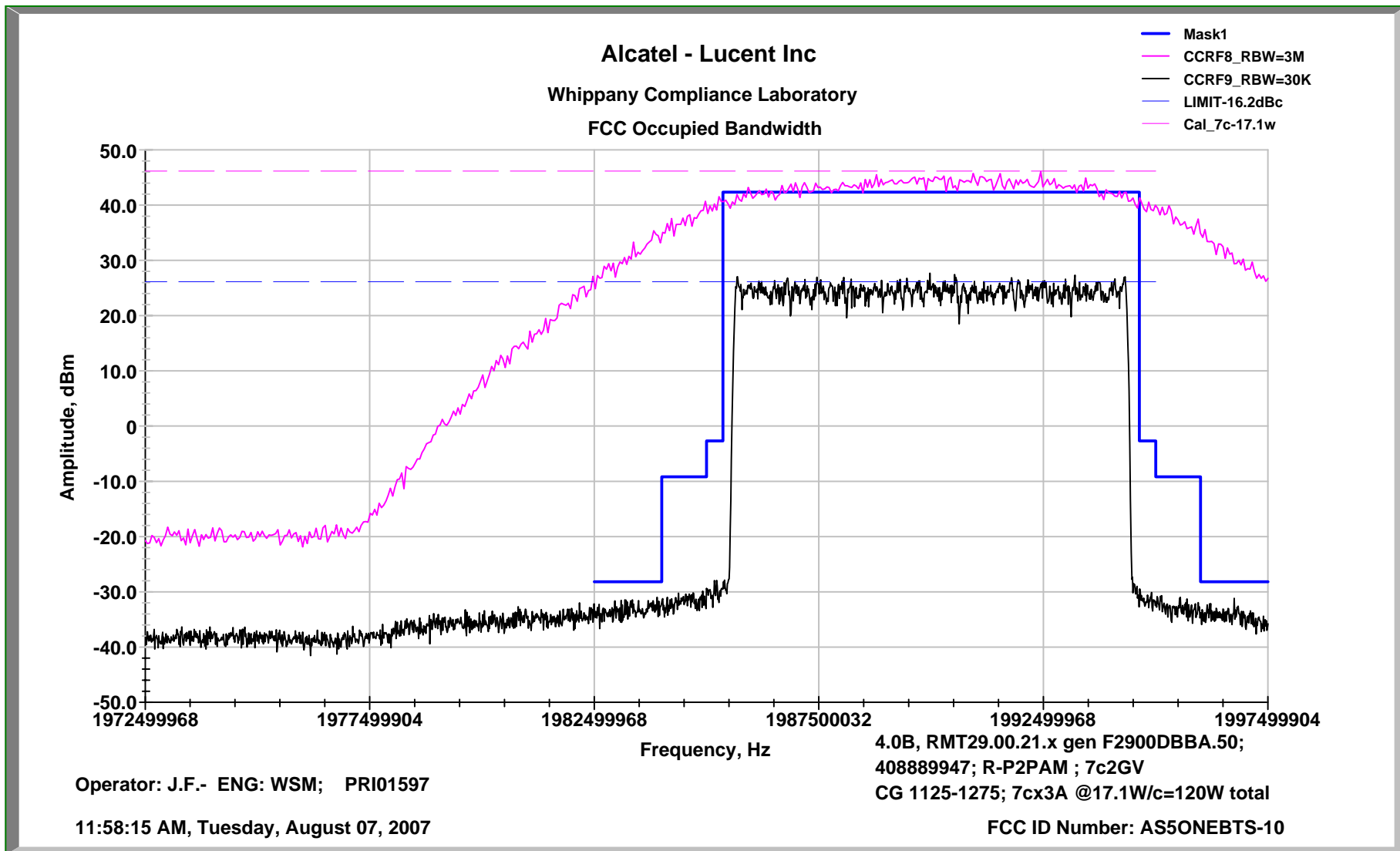

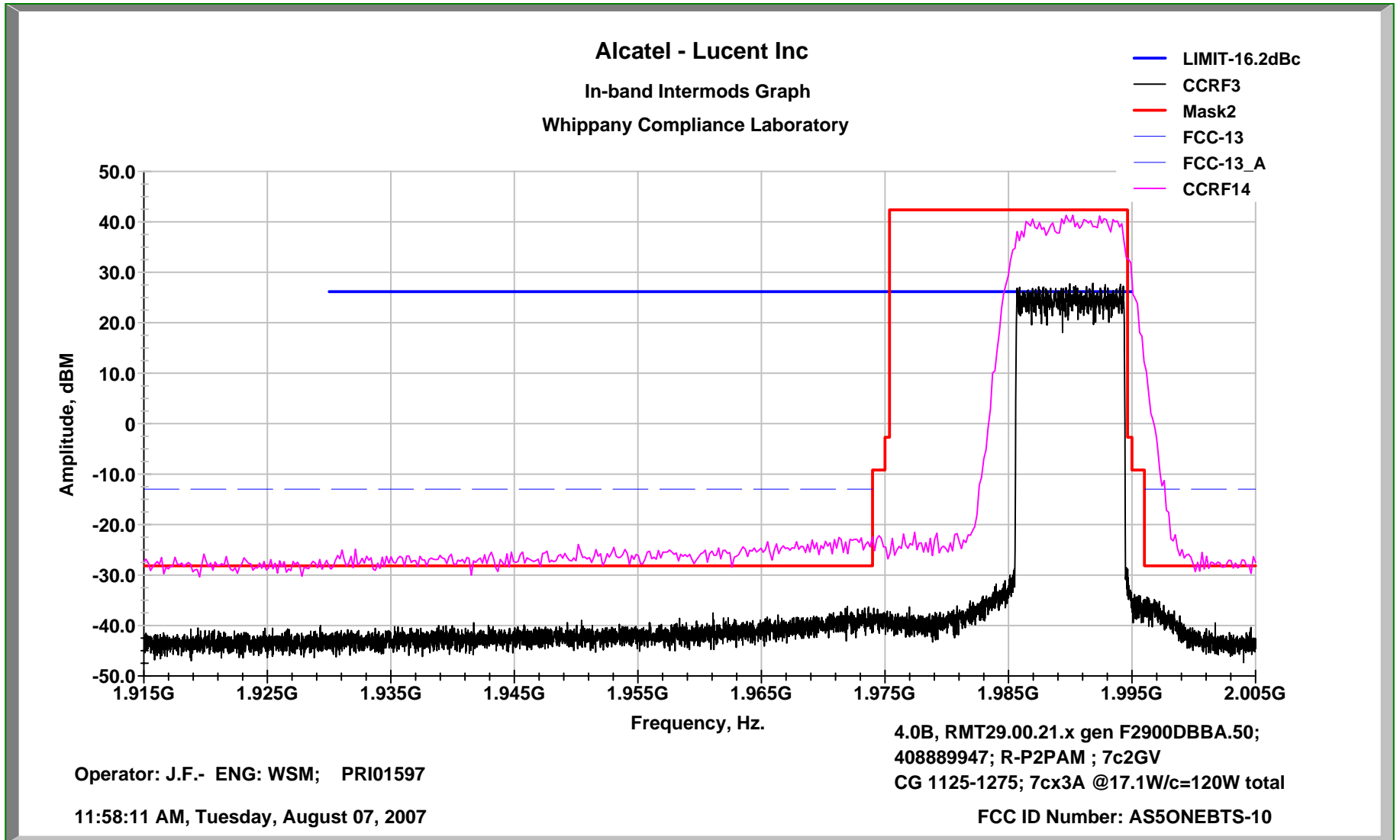

## Exhibit 15: SPURIOUS EMISSIONS AT ANTENNA TERMINALS

### Section 2.1051 Spurious Emissions at Antenna Terminals

Spurious Emissions at the antenna terminals were investigated over the frequency range of 10 MHz to 20 GHz which is beyond the 10th harmonic of the carrier frequency. The RF output from the transmitter was reduced, to an amplitude usable by the spectrum analyzer, by use of a broadband attenuator. The complete RF test path was calibrated over the 10 MHz-20 GHz range. The RF power level was measured and monitored prior to and during the test via the test setup in Figure 15A. The spurious measurements were made using an automated test system. The test system consists of a Rohde & Schwarz FSEM30 Spectrum Analyzer (or ESIB Test Receiver), a PC based computer test controller, calibrated test hardware and a TILE™ software program to acquire the test data. This system allows measurement and presentation of the data in an accurate and compact form for FCC review. The volume of collected data is greater than  $2 \times 10^5$  data points over the frequency range of 10 MHz to 20 GHz.

The required emission limitation specified in Section 24.238 of the Code was applied to these tests. Based upon the criterion given in Section 24.238 of the Code and as developed in Exhibit 14, the required emission limit is -13 dBm when measured with a resolution bandwidth of 1 MHz. The measurements of the spurious signals were therefore made using a resolution bandwidth of 1 MHz. All spurious and harmonics of the CDMA Carrier was also shown to be lower than -13 dBm limit.

The carrier signal shown on these plots was measured at a resolution Bandwidths of 3 MHz. This was done so that the carrier plot correctly and accurately depicts the carrier output power in relation to the spurious signals and the defined limit.

In order to adequately evaluate performance the worst case modulation factors of 2G Voice ( vs. 3G1X or 3G1X-EV-DO) were used from the governing documents. Thus, the applied signal, from a **PCS UMTS-CDMA EDPD Transceiver/ FCC ID: AS5ONEBTS-10**, met the recommended characteristics per "**Table 6.5.2-1 Base Station Test Model, Nominal**" from **3GPP2 TSG-C.S0010-C-v1.00, February 2005**, Recommended Minimum Performance Standards for cdma2000 Spread Spectrum Base Stations, as defined below in table 15.1.

**Exhibit 12** *continued*

Type	Number of Channels	Fraction of Power (Linear)	Fraction of Power (dB)	Comments
Pilot	1	0.2	-7	Code channel $W_0^{128}$
Sync	1	0.0471	-13.3	Code channel $W_{32}^{64}$ ; always 1/8 rate
Paging	1	0.1882	-7.3	Code channel $W_1^{64}$ ; full rate only
Traffic	6	0.09412	-10.3	Variable code channel assignments; full rate only

**TABLE 15.1 Base Station Test Model, Nominal for Main Path**

Type	Number of Channels	Fraction of Power (Linear)	Fraction of Power (dB)	Comments
Transmit Diversity Pilot	1	0.2	-7	Code channel $W_{16}^{128}$
Traffic	6	0.09412	-10.3	Variable code channel assignments; full rate only

**TABLE 15.2 Base Station Test Model, Nominal for Transmit Diversity Path**

The FCC limits contained in **47CFR 24.238 1-Oct-2005** were followed along with the minimum standard presented in **3GPP2 TSG-C.S0010-B-v2.0 March 2004**.

**Test Results Summary:**

Conducted Spurious measurements were performed for the seven and eight carrier **PCS UMTS-CDMA EDPD Transceiver** configurations supporting operation at 17.1 Watts/c for seven carriers and for operation at 15 Watts/c for eight carriers. Conducted Transmit Spurious measurements were performed as part of the test profile for Occupied bandwidth. Every PCS Block Edge measurements configuration therefore included a Conducted Transmit Spurious measurements as documented in Table 15.2.

The attached spectral plots are representative of the Conducted Spurious compliance performance of the **PCS UMTS-CDMA EDPD Transceiver**. The compliance for all of the representative transmit configurations are documented in Table 15.2. This Table lists PCS Blocks/ Channels tested the amplifier configuration and the status of the performance. The performance data, charts and tables all show that there are no “Out of Block” harmonics or spurious emissions above the applicable limit of -13 dBm. The attached table and sample data plots document the results.

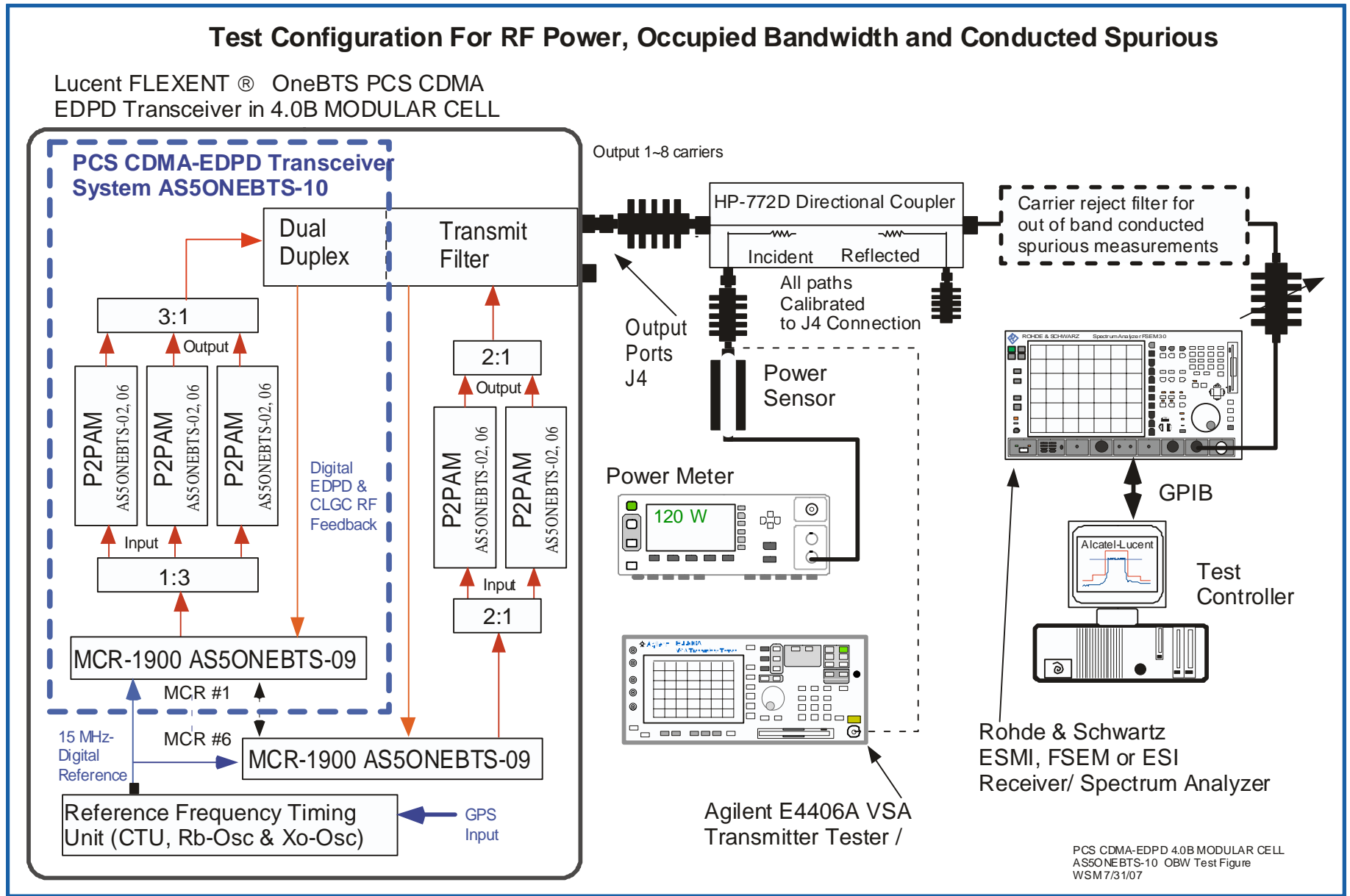

Exhibit 15 *continued*

PCS - Block	PCS - Channels	Number of carriers	Amplifier Type	# of amplifiers in MCA	Results Conducted Spurious
<b>7 Carrier Configuration</b>					
A	25 - 175	7	P2PAM	3	Compliant
A	125-275	7	P2PAM	3	Compliant
A + D	225 - 375	7	P2PAM	3	Compliant
B	425 - 575	7	P2PAM	3	Compliant
B	525-675	7	P2PAM	3	Compliant
B + E	625 - 775	7	P2PAM	3	Compliant
F + C	825 - 975	7	P2PAM	3	Compliant
C	925-1075	7	P2PAM	3	Compliant
C	1025-1175	7	P2PAM	3	Compliant
C + G	1100-1275	7	P2PAM	3	Compliant
C+G	1125-1275	8	P2PAM	3	Compliant
<b>8 Carrier Configuration</b>					
A	25 - 200	8	P2PAM	3	Compliant
A	100-275	8	P2PAM	3	Compliant
A + D	200 - 375	8	P2PAM	3	Compliant
B	425 - 600	8	P2PAM	3	Compliant
B	500-675	8	P2PAM	3	Compliant
B + E	600 - 775	8	P2PAM	3	Compliant
F + C	825 - 1000	8	P2PAM	3	Compliant
C	925-1100	8	P2PAM	3	Compliant
C	1000-1175	8	P2PAM	3	Compliant
C + G	1100-1275	8	P2PAM	3	Compliant

**TABLE 15.2 PCS Conducted Spurious Compliance Tabulation**

**Figure 15A Test Setup for Antenna Port Measurement of Transmit Power, Occupied Bandwidth and Conducted Spurious Emissions**



**Transmitter Measurements  
of  
Conducted Spurious Emissions  
for  
Lucent Technologies Inc.  
PCS UMTS-CDMA EDPD Transceiver  
FCC ID: AS5ONEBTS-10  
Installed in  
FLEXENT PCS CDMA Modular Cell 4.0  
Operational Configurations  
8c at 15W/carrier, 120W Total  
and  
7c at 17.1W/carrier, 120W Total**

**Conducted Spurious Emissions  
Test Report  
AS5ONEBTS-10  
8 carriers at 15 W/carrier 120 Watts Total  
using  
3x P2PAMs**

Conducted Emissions 10 MHz – 10 GHz 8cx3A 15W/c 6c 2GV + 2c-DO Block A1 Ch 25-200 J4=120W

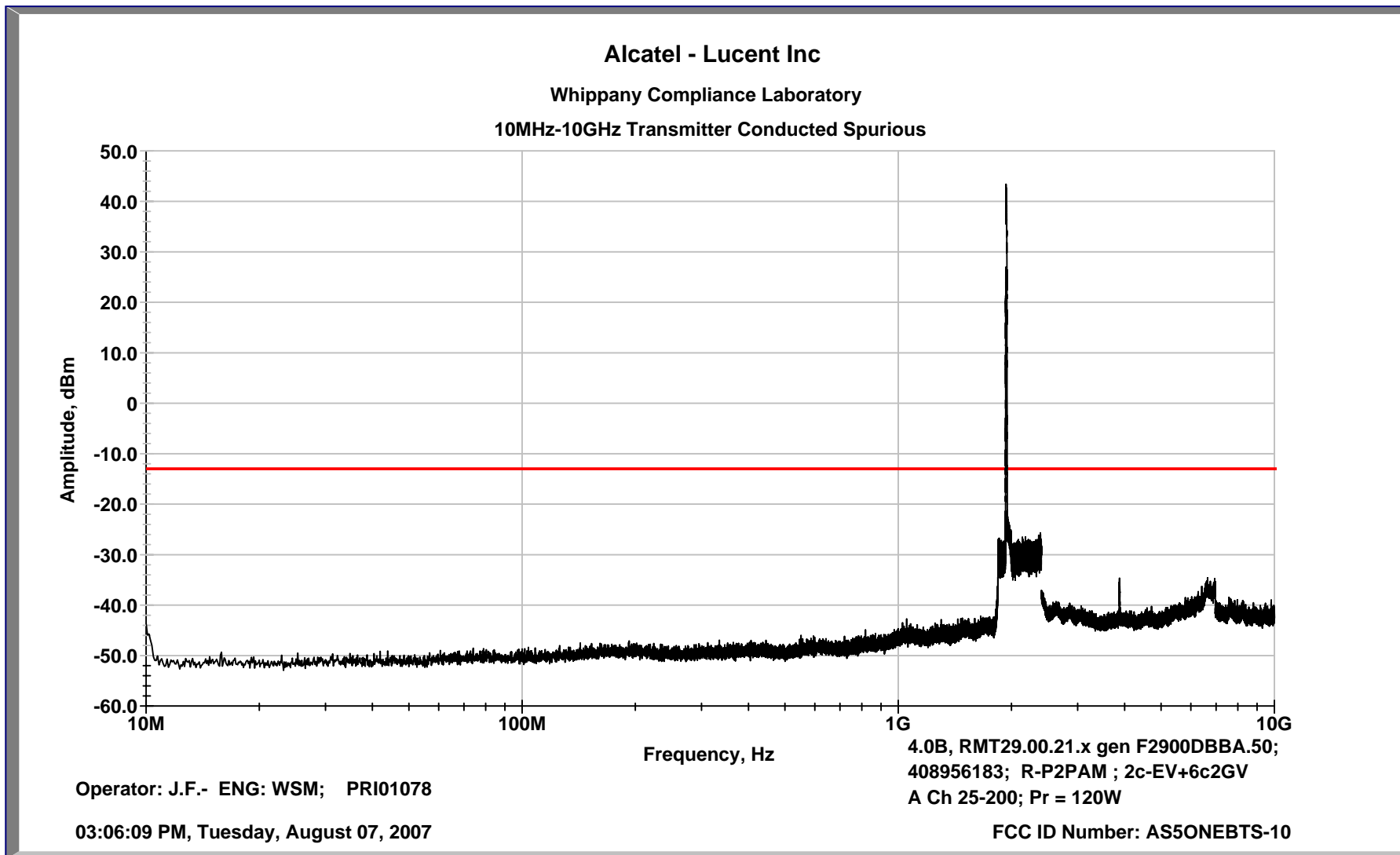

Conducted Emissions 1 GHz – 20 GHz 8x3A 15W/c 6c 2GV + 2c-DO Block A1 Ch 25-200 J4=120W

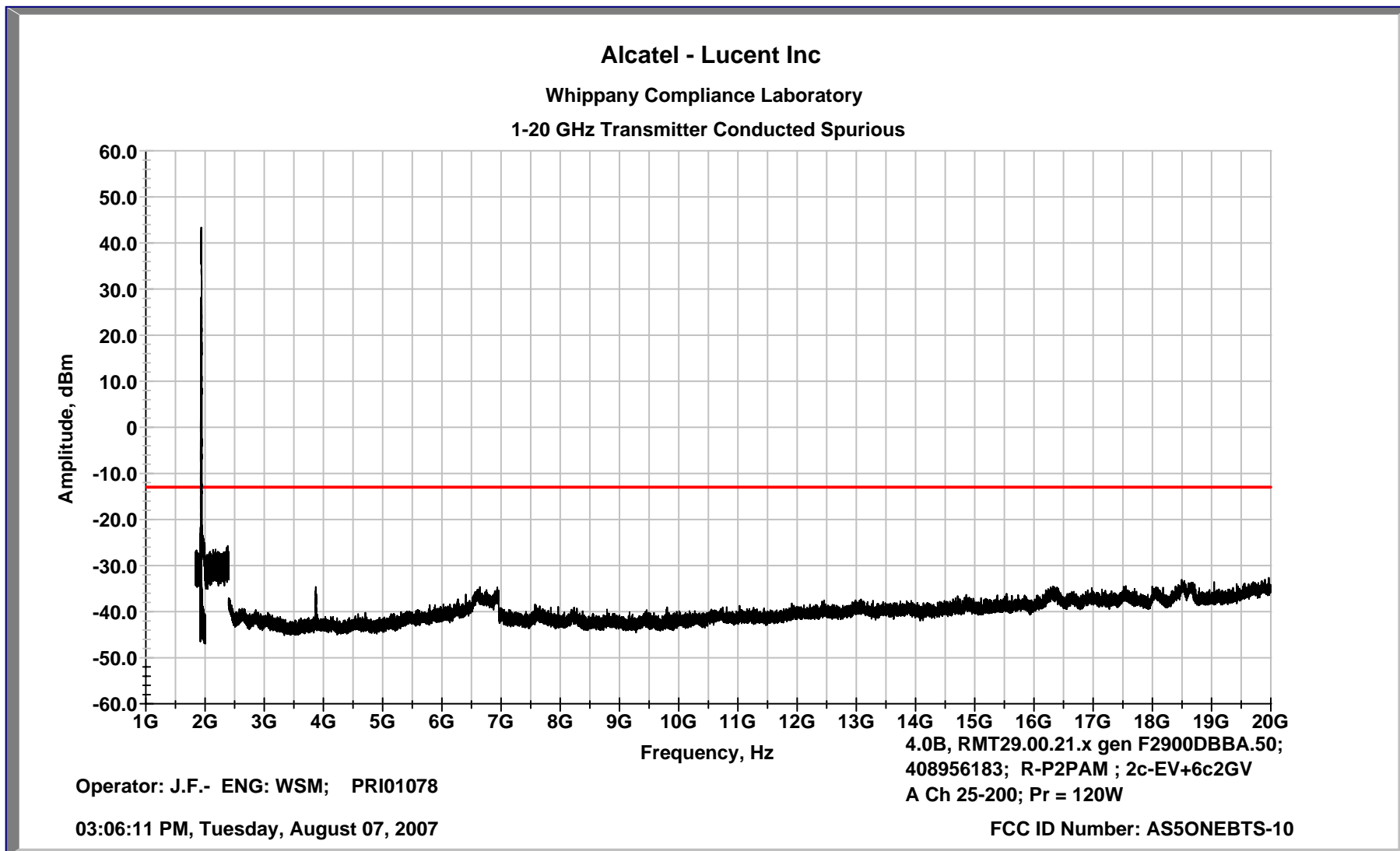

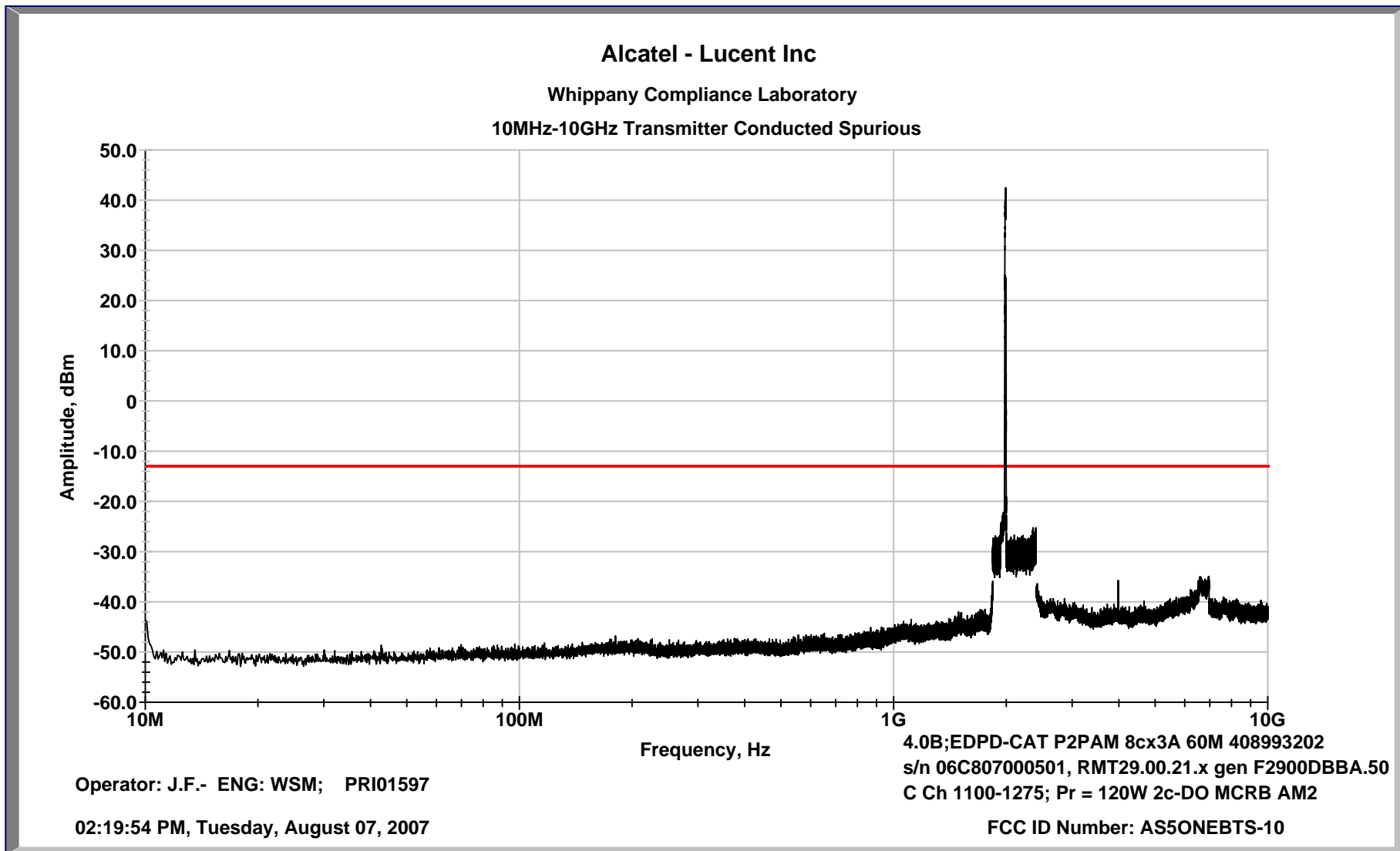

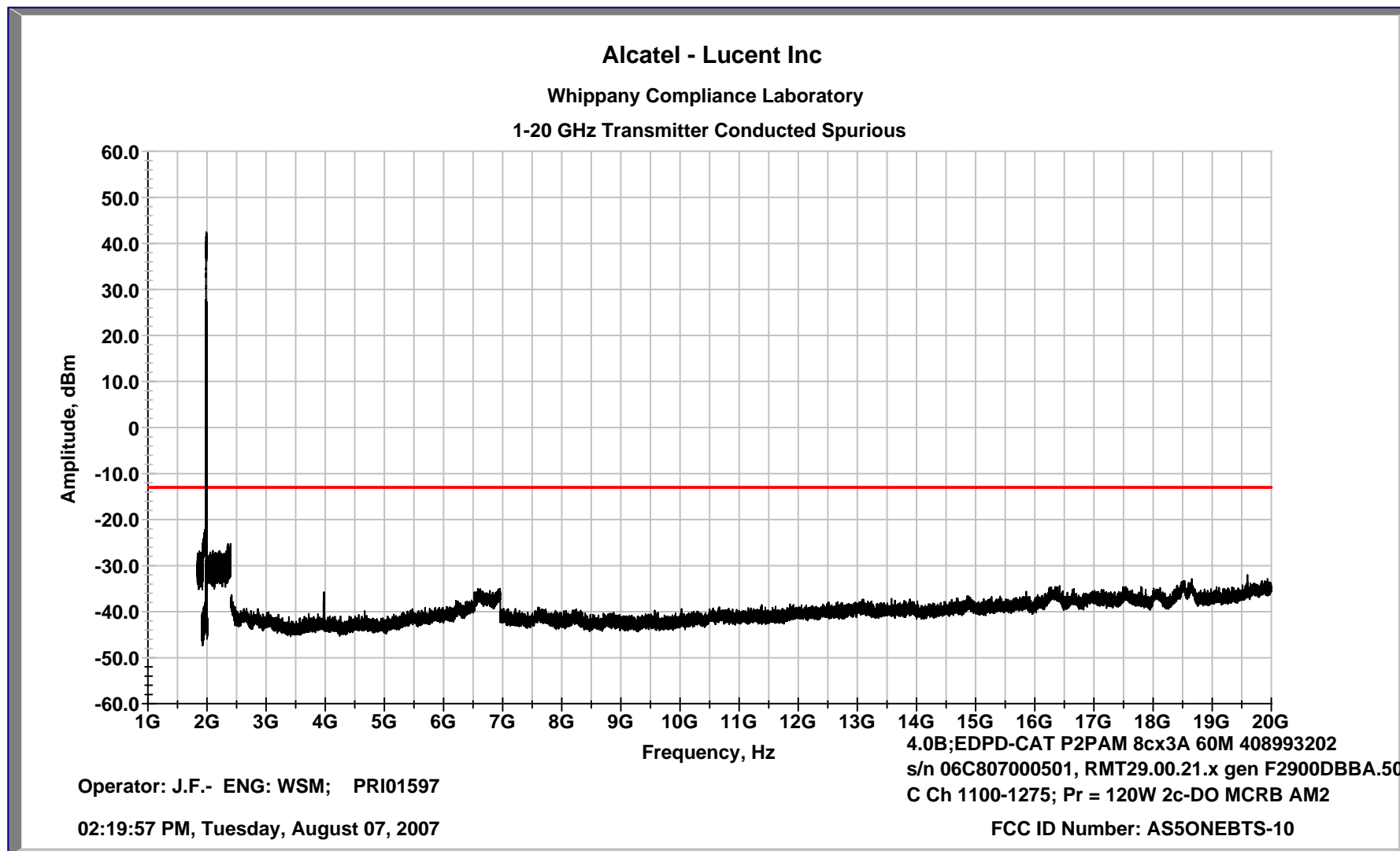



**Conducted Spurious Emissions  
Test Report  
AS5ONEBTS-10  
7 carriers at 17.1 W/carrier 120 Watts Total  
using  
3x P2PAMs**

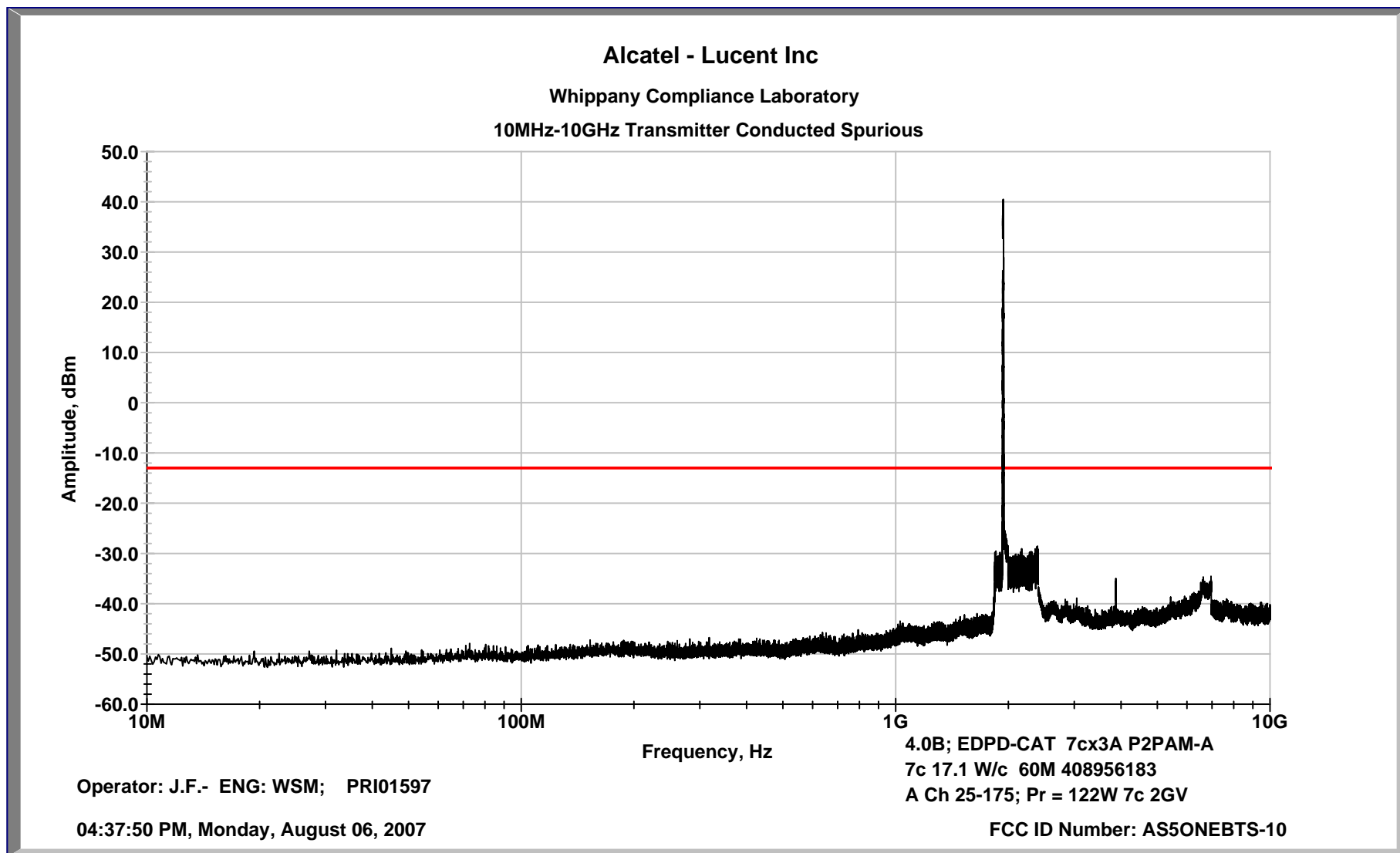

Conducted Emissions 1 GHz – 20 GHz 7cx3A 17.14W/c 2c-DO Block A1 Ch 25-175 Andrew Amplifiers J4=120W

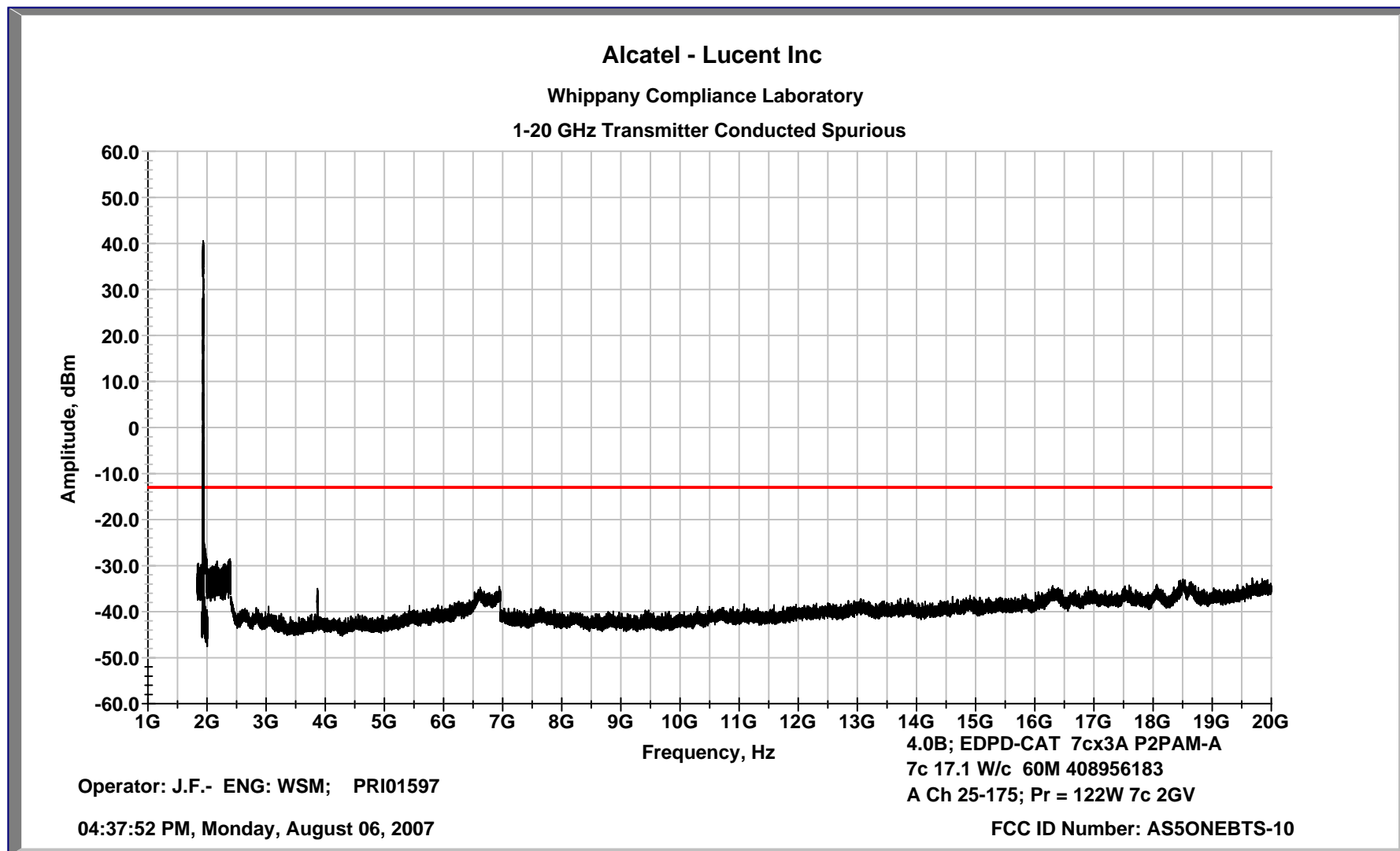

Conducted Emissions 10 MHz - 10 GHz

7cx3A Blocks C-G Ch 1125, 1275

J4=120W

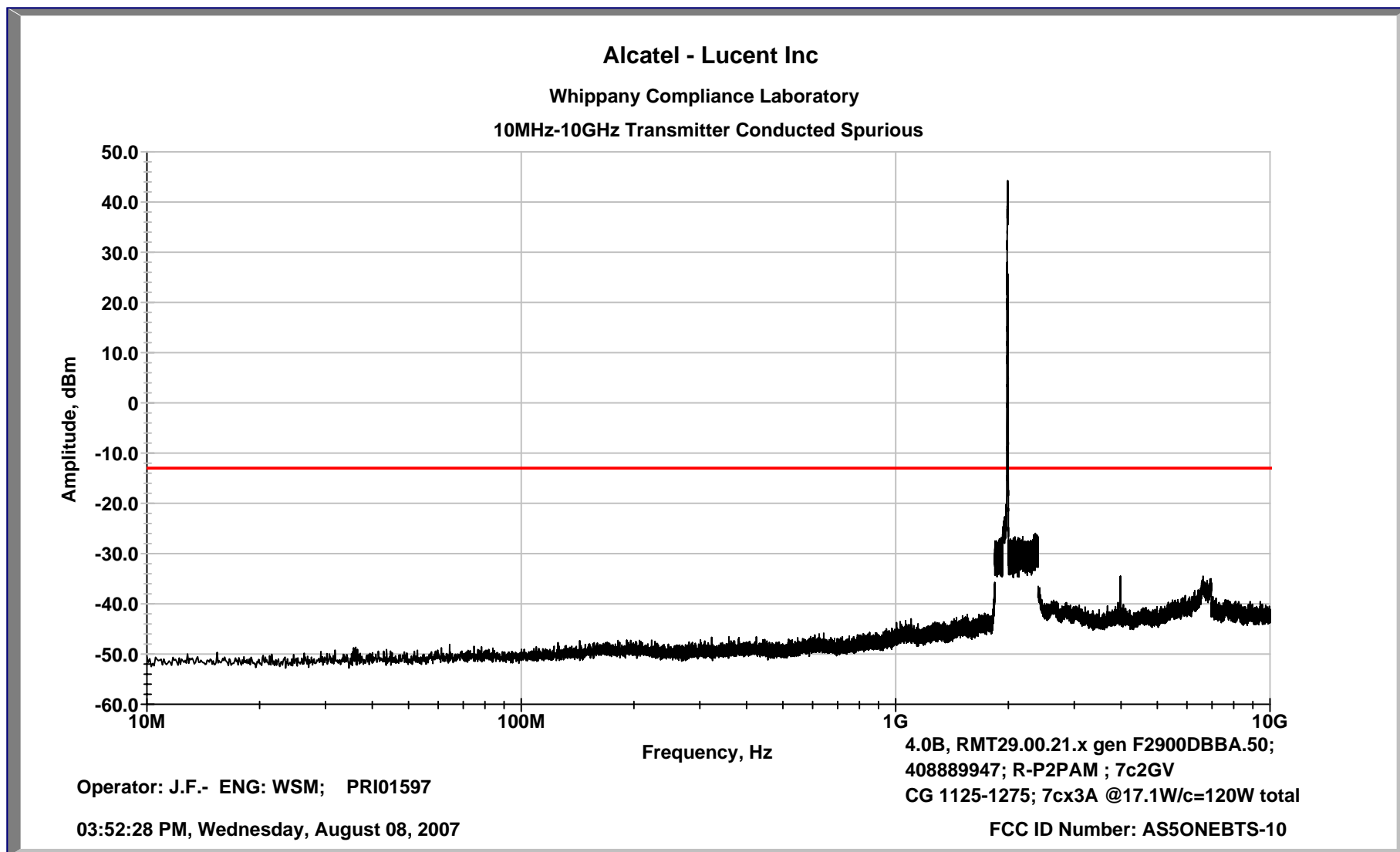

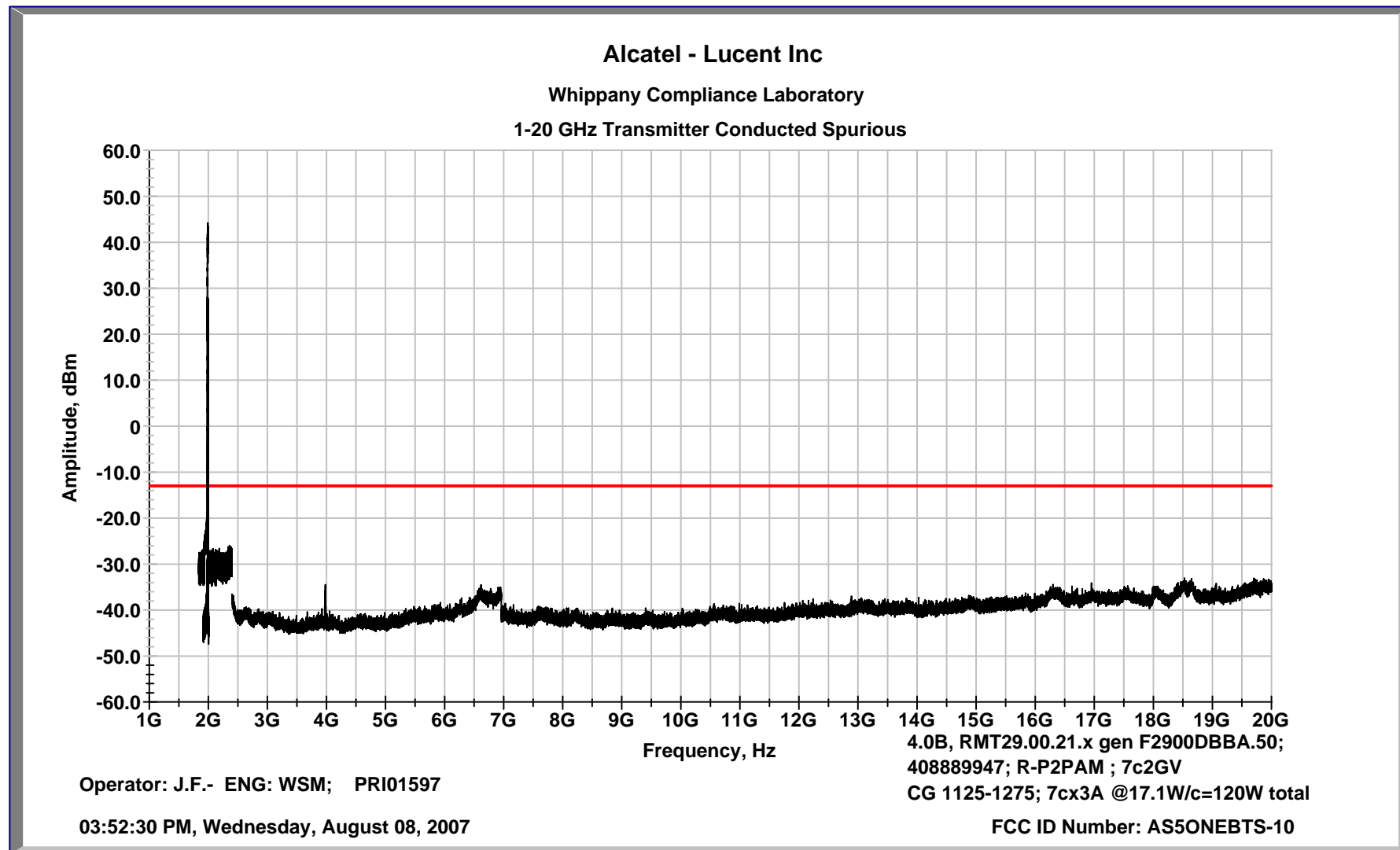

**Exhibit 16 FIELD STRENGTH OF SPURIOUS RADIATION**

**SECTION 2.1053 Field Strength Of Spurious Radiation**

Field strength measurements of radiated spurious emissions were evaluated in a 3m anechoic pre-compliance chamber and verified as required at the ten meter Open Area Test Site OATS maintained by Lucent Technologies Bell Laboratories FCC Compliance Laboratory in Whippany, New Jersey. A complete description and full measurement data for the site have been placed on file with the Commission.

The **MCR1900s** were configured with **P2PAMs** and all other associated equipment in a **PCS Indoor FLEXENT® OneBTS Modular Cell 4.0 frames** operating in all PCS blocks as four **PCS UMTS-CDMA EDPD Transceivers/ FCC ID: AS5ONEBTS-10**. The spectrum from 10 MHz to the tenth harmonic of the carrier (20 GHz) was searched for spurious radiation. Measurements were made using both horizontally and vertically polarized broadband antennas. Per FCC regulations, the comparison of out of band spurious emissions directly to the limit is appropriately made using the substitution method. However, when the emissions are more than 20 dB below the specification limit, the use of field strength measurements for compliance determination is acceptable and those emissions are considered not reportable (Section 2.1053 and the FCC Interpretive database for 2.1053). For this case the evaluation of acceptable radiated field strength is as follows.

The calculated emission levels were found by:

$$P_{meas} \text{ (dBm)} + \text{Cable Loss(dB)} + \text{Antenna Factor(dB)} + 107 \text{ (dB}\mu\text{V/dBm)} - \text{Amplifier Gain (dB)} \\ = \text{Field Strength (dB}\mu\text{V/m)}$$

Section 24.238 and 2.1053 contains the requirements for the levels of spurious radiation as a function of the EIRP of the unmodulated carrier. The reference level for the unmodulated carrier is calculated as the field produced by an isotropic radiator excited by the transmitter output power according to the following relation taken from Reference Data for Radio Engineers, page 27-7, 6th edition, IT&T Corp.

$$E = (120\pi P)^{1/2} = [(30 \cdot P)^{1/2}] / R$$

$$20 \log (E \cdot 10^6) - (43 + 10 \log P) = 71.77 \text{ dB } \mu\text{V/meter}$$

Where: E = Field Intensity in Volts/ meter                                  R = Distance in meters = 10 m  
 P = Transmitted Power in watts = 17.1 or 15 W/ Carrier

**RESULTS:**

For this particular test, the field strength of any spurious radiation, measured at 10m, is required to be less than 71.8 dBμV/meter. Emissions equal to or less than 51.8 dBμV/meter are not reportable and may be verified using field strength measurements and broadband antennas. Over the out of band spectrum investigated from 10 MHz to beyond the tenth harmonic of the carrier (20GHz), no reportable spurious emissions were detected. This demonstrates that the **PCS UMTS-CDMA EDPD Transceiver/ FCC ID: AS5ONEBTS-10**, the subject of this application, complies with Sections 2.1053, 24.238 and 2.1057 of the Rules.

Although not required for certification, additional testing to 47CFR Part 15 documented compliance with the Class B requirements for radiated emissions.

## **Exhibit 17                      MEASUREMENT OF FREQUENCY STABILITY**

### **SECTION 2.1055    Measurement of Frequency Stability**

The design and performance of the MCR-1900 has not been changed. The frequency stability performance remains within the parameters as previously filed.

#### **Previous results:**

**The previously filed data documented that the maximum frequency deviation measured for the RF carrier frequency (1957.5 MHz) at the transmit antenna port was +0.00062 ppm (1.21 Hz). The specification for FCC compliance is +/- 0.05 ppm (+/- 97.87 Hz). The maximum frequency deviation measured for the OMU-RB output (15MHz) was +0.00004 ppm ( $7 \times 10^{-4}$  Hz). The specification for FCC compliance is +/- 0.05 ppm (+/-0.75 Hz).**