

**MEASUREMENT OF RADIO FREQUENCY POWER OUTPUT**  
**SECTION 2.1046**

**MEASUREMENT: 1****MEASUREMENT OF RADIO FREQUENCY POWER OUTPUT****SECTION 2.1046**

The test arrangements used to measure the radio frequency power output of the FCC ID: AS5FLX-01 "Flexent GSM 1900 Transceiver" Model TRX19 is shown on following pages. Measurements were made respectively at each frequency where occupied Bandwidth measurements were performed. The use of the TRX19 is for a Single GSM Carrier. This requires that the power level at J4 connector be calibrated for the specific channel of use. The test configuration, Figure 1A and Figure 1B, allowed the measurement of RF output power for channels investigated for Occupied Bandwidth. The test set up for Figure 1A for two composite carriers and Figure 1B for single carrier. The measurements were made at upper lower band edges and at the center channel for each Band.

Measurements were made at J4 connector terminals for following configurations:

1. Single carrier with TRX19 output directly connected to J4.
2. A composite power for two carrier combined.
3. Single carrier with TRX19 output connected to a J4 through a passive combiner.

A single TRX19 system has a maximum power output at the antenna terminals of 29 Watts (44.6 dBm)  $\pm 1/2$  dB, it also has a minimum power output at the antenna terminals of 0.002 Watts ( $\pm 1/2$  dB), across the PCS band (1930.4 –1989.6 MHz).

Two TRX19s combined system for two carriers have a maximum composite power output at the antenna terminals of 29 Watts (44.6 dBm)  $\pm 1/2$  dB, it also has a minimum power output at the antenna terminals of 0.005 Watts ( $\pm 0.5/2$  dB), across the PCS band (1930.4 –1989.6 MHz).

A single TRX19 connected to a passive combiner with second input port terminated has a maximum composite power output at the antenna terminals of 18 Watts (42.6 dBm)  $\pm 1/2$  dB, it also has a minimum power output at the antenna terminals of 0.005 Watts ( $\pm 1/2$  dB), across the PCS band (1930.4 –1989.6 MHz).

Digitized pseudo-random traffic stored in an EROM in TRX19 was used as input.

**MEASUREMENT: 1**

**MEASUREMENT OF RADIO FREQUENCY POWER OUTPUT**

**EQUIPMENT:**

<b>BTS :</b>	<b>Flexent GSM indoor Macrocell cabinet.</b>
<b>TRX19:</b>	<b>Flexent GSM 1900 Transceiver.</b>
<b>ACU 19-4UV</b>	<b>Combiner</b>
<b>Transmit Filter:</b>	<b>Cellular Band Transmit Filter</b>
<b>Directional Coupler:</b>	<b>HP 778D Dual Directional Coupler</b>
<b>Power Meter:</b>	<b>HP 437B with HP 8481A Power Head</b>
<b>Plotter:</b>	<b>HP Model 520 DeskJet</b>
<b>Spectrum Analyzer:</b>	<b>HP 8595E</b>

**RESULTS:**

The TRX19 was configured in the test setup shown in Figure 1A and Figure 1B.

1. Single carrier with TRX19 output directly connected to J4. Maximum RF output power measured: 29W
2. A composite power for two carrier combined. Maximum RF output power measured: 29 W
3. Single carrier with TRX19 output connected to a J4 through a passive combiner. Maximum RF output power measured: 18W

For (1) and (2) above, the data is recorded on the TRX19 Occupied Bandwidth Data Sheets.

**Figure 1A. TEST CONFIGURATION FOR RF POWER OUTPUT**

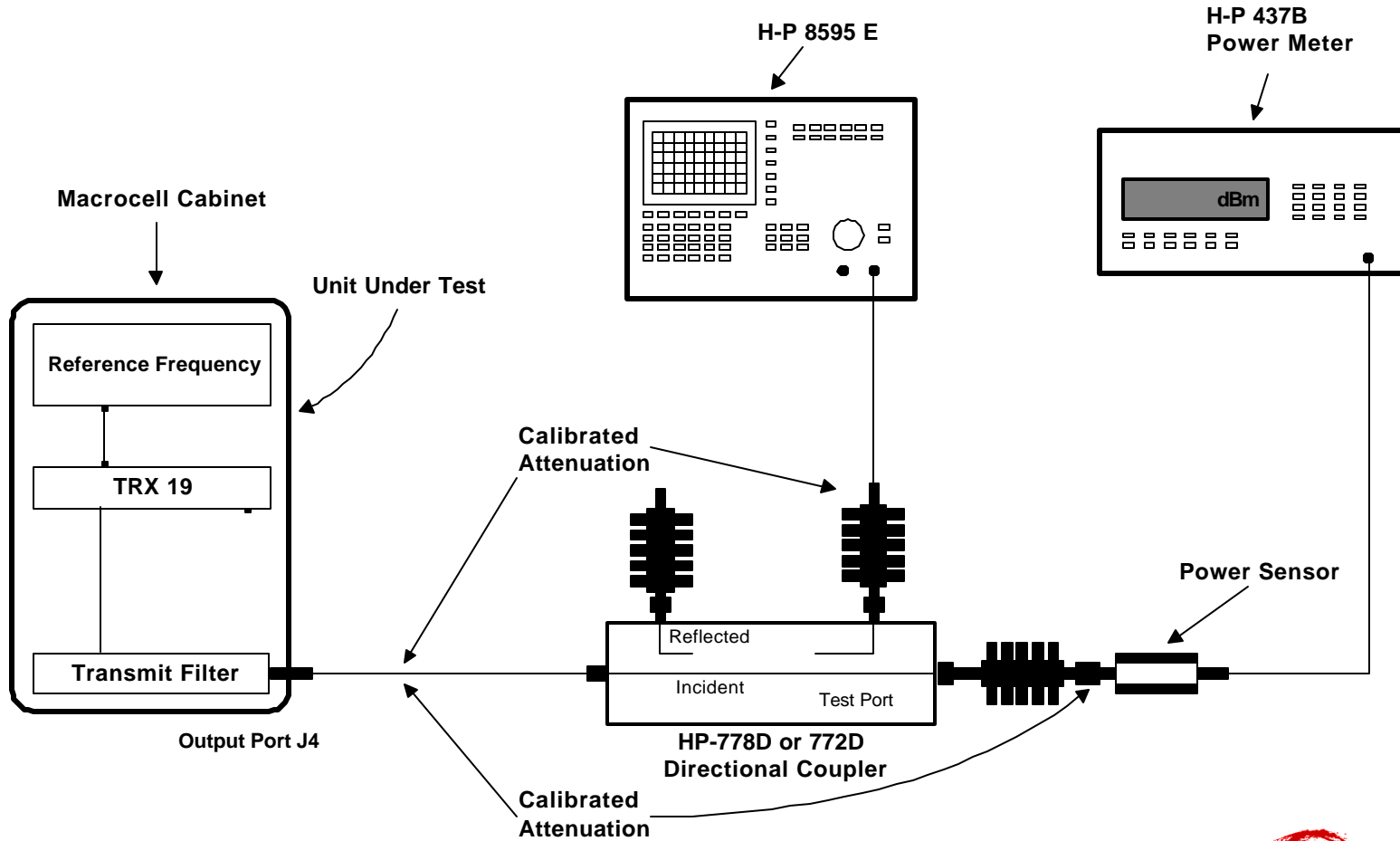

Lucent Technologies Inc. - Proprietary  
 Use pursuant to Company Instructions

All components are calibrated over the frequency range of interest

**Lucent Technologies**  
 Bell Labs Innovations



APPLICANT: Lucent Technologies

FCC ID: AS5FLX-01

**Figure 1B. TEST CONFIGURATION FOR RF POWER OUTPUT**

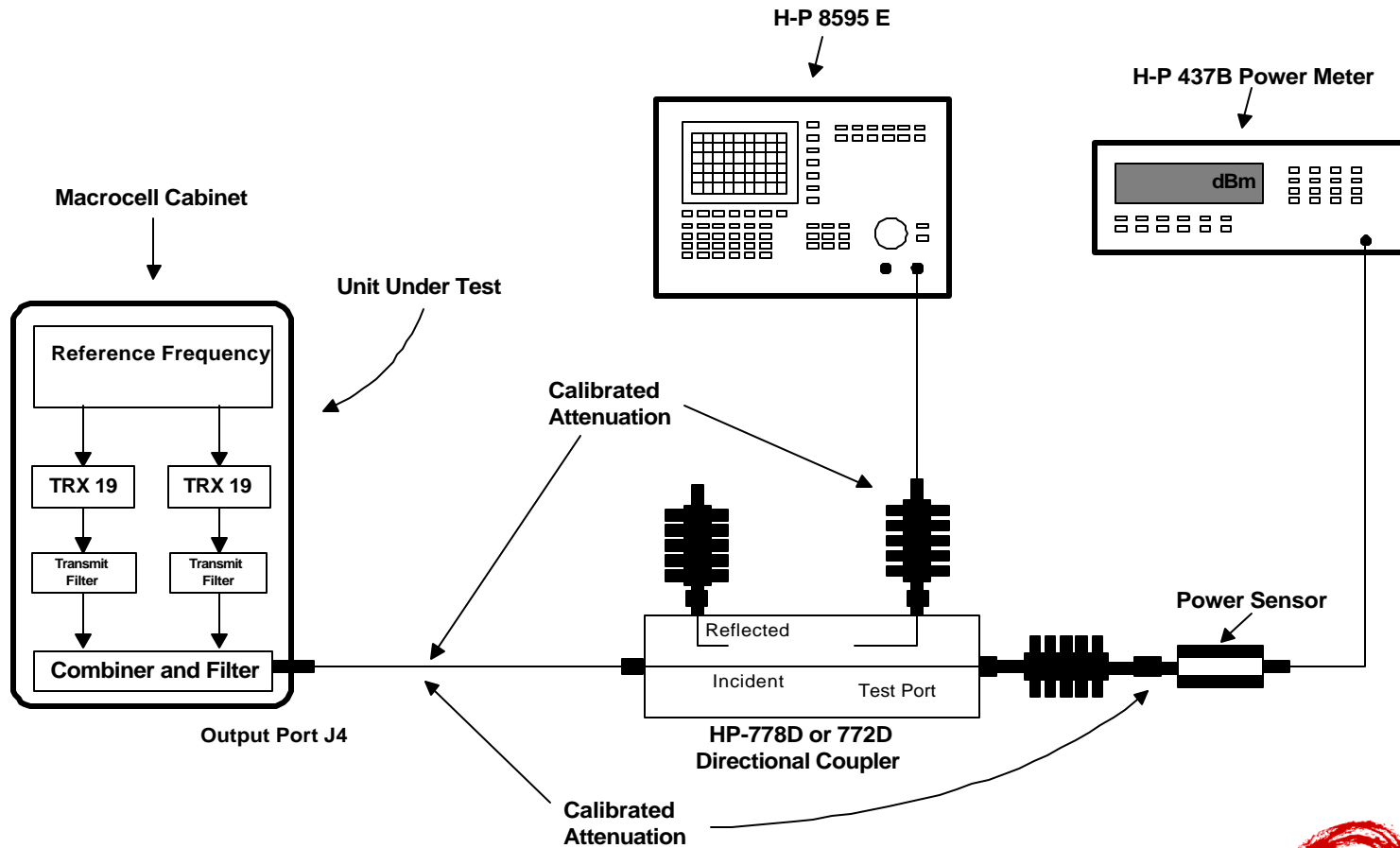

All components are calibrated over the frequency range of interest

**Lucent Technologies**  
Bell Labs Innovations



Lucent Technologies Inc. - Proprietary  
Use pursuant to Company Instructions

APPLICANT: Lucent Technologies

FCC ID: AS5FLX-01