

SPURIOUS EMISSIONS AT ANTENNA TERMINALS
SECTION 2.1051

MEASUREMENT: 4

Section 2.1051

Spurious Emissions at the antenna terminals and input to ICLA were investigated over the frequency range of 0 MHz to the 10th harmonic of the carrier frequency. The test setup was as described in Figure 4A. Measurements were made using a Rohde & Schwarz FSEK Spectrum Analyzer and an HP Model 520 DeskJet Printer. The RF output from the transmitter was reduced (to an amplitude usable by the spectrum analyzer) by using a calibrated attenuator. The RF power level was continuously monitored via RF Power Meter as shown in the test setup in Figure 4A. The required emission limitation specified in Section 22.917 of the Code was applied to these tests. The applied signal met the recommended characteristics per IS-97 as defined in Table 4.1. All measurements were made for 24W (43.8 dBm) output at antenna terminals. The corresponding PCBR output was 8.4 dBm approximately.

Based upon the criterion given in Section 22.917 of the Code the required emission limitation is equal to -56.8 dBc or - 13 dBm. The magnitude of spurious emissions that are attenuated more than 20 dB below the permissible value need not specified (Section 2.1051 and 2.1057 (a) and (c)).

Type	Number of Channels	Fraction of Power (Linear)	Fraction of Power (dB)	Comments
Pilot	1	0.2000	-7.0	Walsh 0
Sync	1	0.0471	-13.3	Walsh 32, always 1/8 rate
Paging	1	0.1882	-7.3	Walsh 1, full rate only
Traffic	6	0.09412 each	-10.3 each	Variable Walsh Assignments, full rate only

TABLE 4.1. Base Station Test Model, Nominal

Table 4.2. IS 97 channel allocation consists of following channel Blocks:

Block	FCC Cellular Frequency Bands Per FCC 22.905 MHz	Valid CDMA Channels & Frequency Range	
		Channel No.	MHz
A'' (1 MHz)	869.000 - 870.000	1013 -1023	869.700 – 870.000
A (10 MHz)	870.000 - 880.000	0001- 0311	870.030 – 879.330
B (10 MHz)	880.000 - 890.000	0356 - 0644	880.680 – 889.320
A' (1.5 MHz)	890.000 - 891.500	0689 - 0694	890.670 – 890.820
B' (2.5 MHz)	891.500 - 894.000	0739 - 0777	892.170 – 893.310

The edge channels are 1013 and 0777.

Table 4.3. The frequency range used by ICLA and for FCC filing.

Block	Valid CDMA Channels	Frequency Range
A	016-283	870.48 – 878.49 MHz
B	384-617	881.52 – 888.51 MHz

Plots are provided for Left Edge, center and Right Edge of cellular bands A, and B for the channels covered in the frequency ranges used by ICLA as indicated in Table 4.3. The Plots provided to show outside the cellular band (869 to 894 MHz), the emissions are less than -1 3dBm.

RESULTS:

The attached spectral plots document for spurious emissions at antenna terminal shows that there are no emissions above the applicable limit.

Figure 4A. TEST CONFIGURATION FOR CONDUCTED SPURIOUS

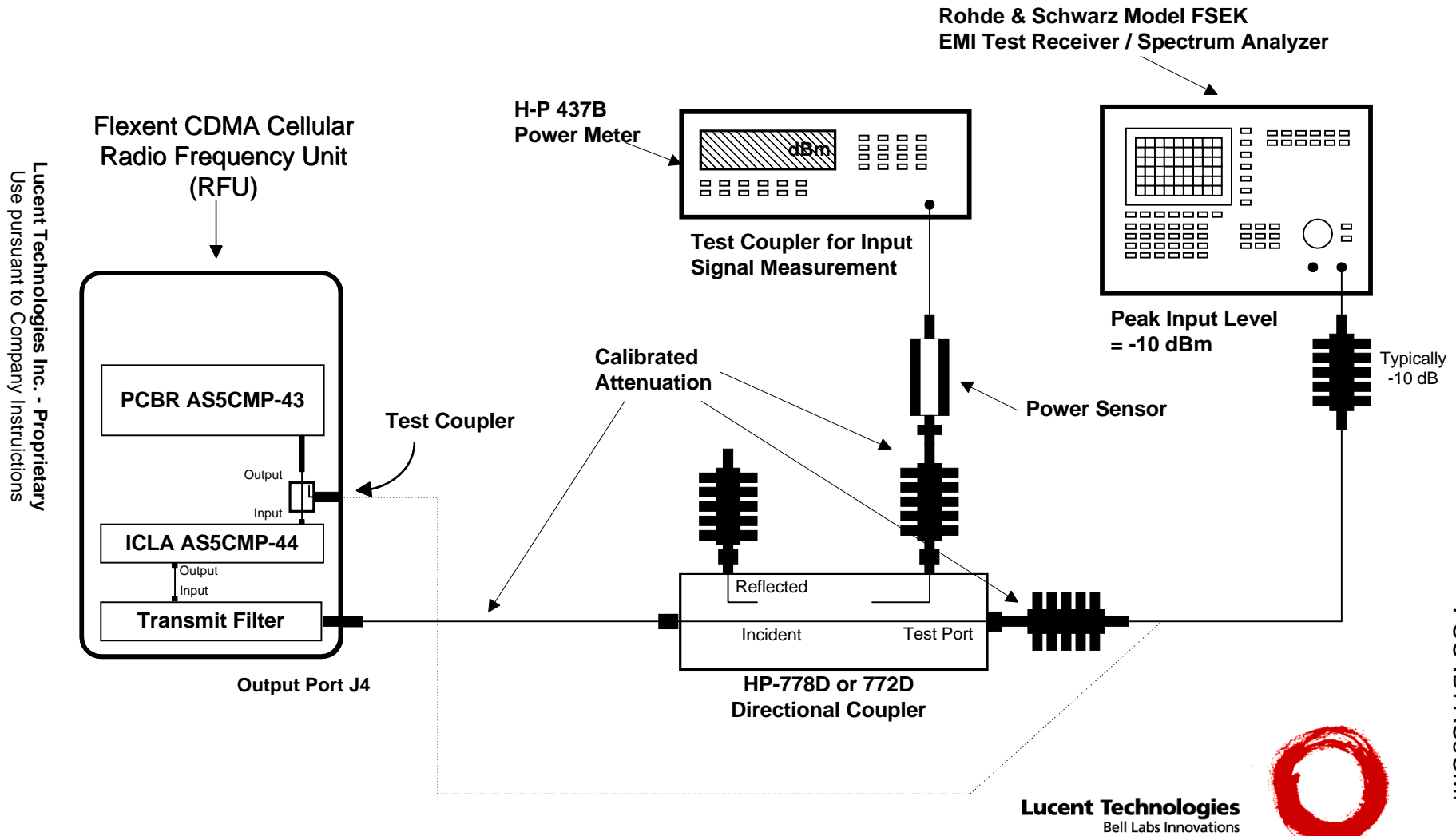

MEASUREMENT: 4

MEASUREMENT

OF

ANTENNA CONDUCTED SPURIOUS

BLOCK A

(870-880 MHz)

Left Edge:	870.48 MHz (Channel 016)
Center:	873.99 MHz (Channel 133)
Right Edge:	878.49 MHz (Channel 283)



Ref Lvl
43.8 dBm

RBW 30 kHz RF Att 30 dB
VBW 300 kHz
SWT 500 ms Unit dBm

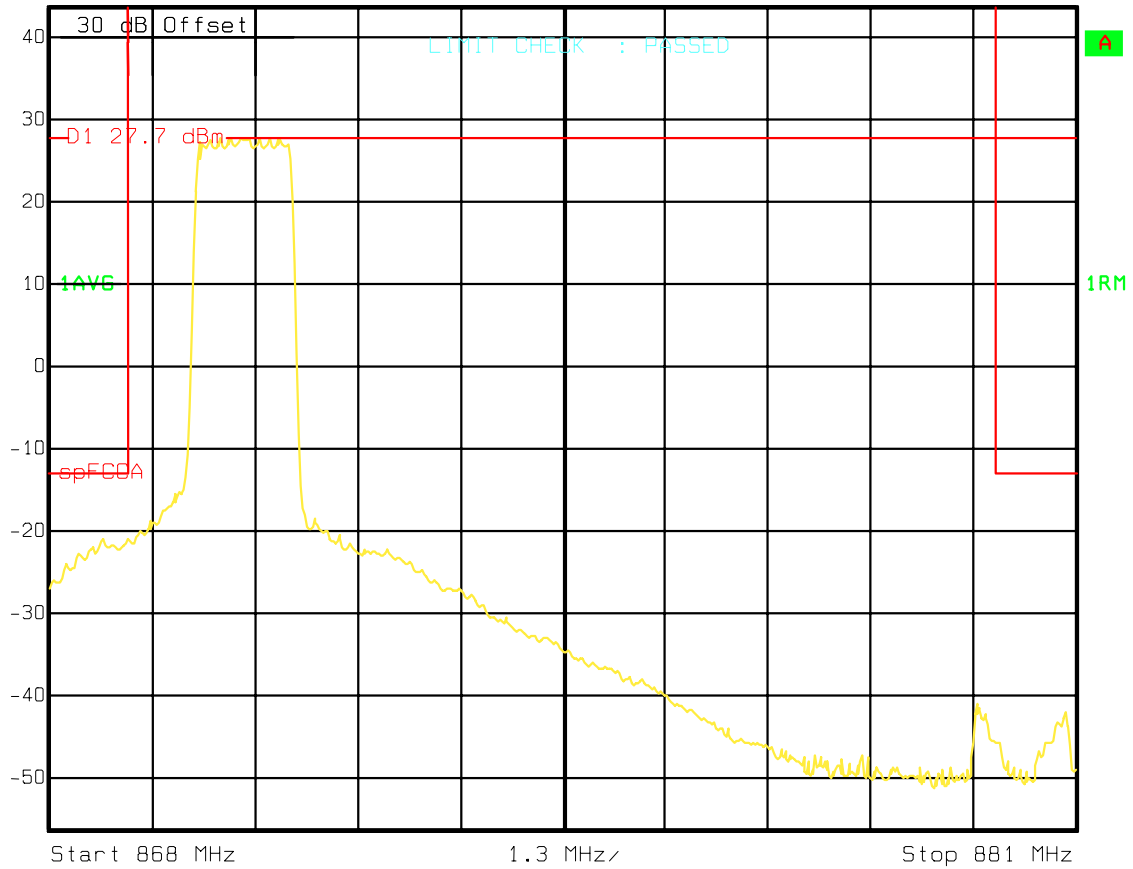

Title: Spurious Emissions at TX antenna
Comment A: FCC ID: AS5CMP-44. Flexant CDMA MicroMini Cell (duplex)
Channel 16. Power= 24 Watts.
Date: 10.NOV.2000 16:22:59

Left Side -13 dBm limit Frequency is 869 MHz



Ref Lvl
43.8 dBm

RBW 30 kHz RF Att 30 dB
VBW 300 kHz
SWT 2.8 s Unit dBm

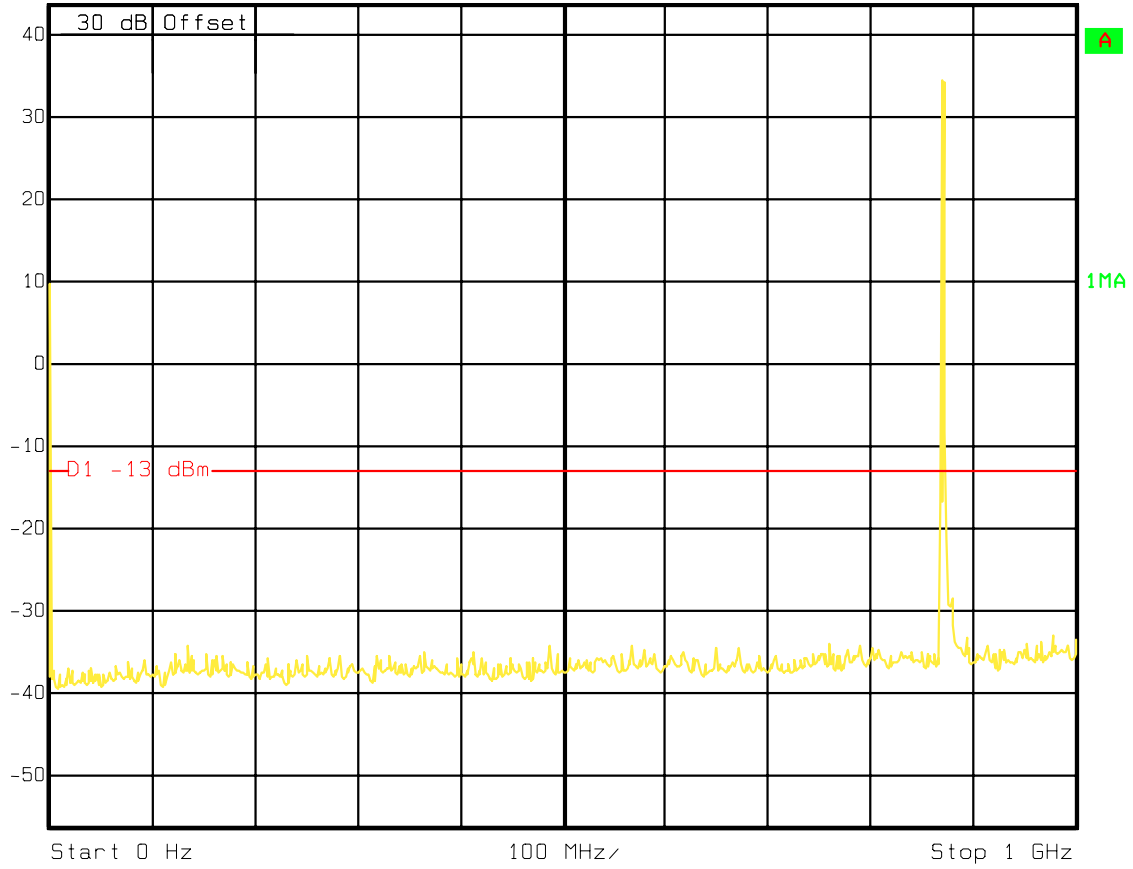

Title: Spurious Emissions at TX antenna
Comment A: FCC ID: AS5CMP-44. Flexant CDMA MicroMini Cell (duplex)
Channel 16. Power= 24 Watts.
Date: 10.NOV.2000 15:06:33



Ref Lvl
43.8 dBm

RBW 30 kHz RF Att 30 dB
VBW 300 kHz
SWT 11.5 s Unit dBm

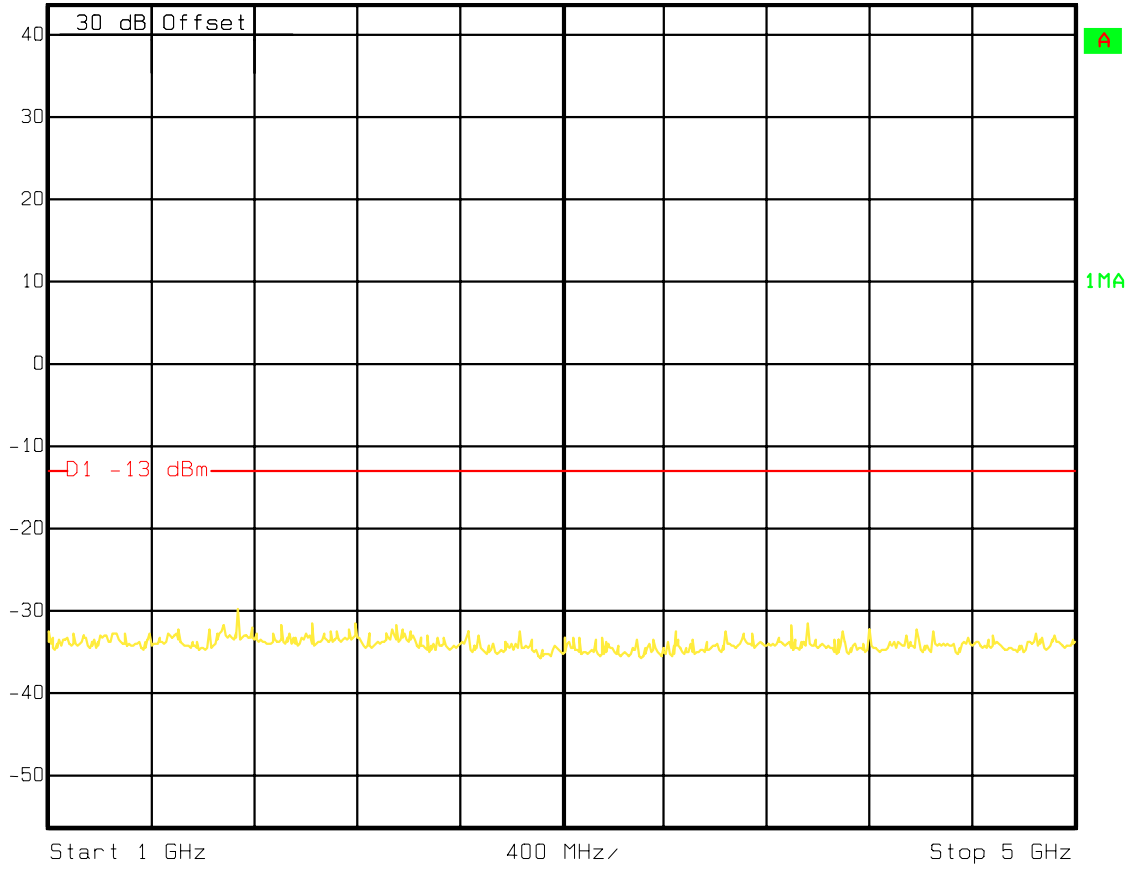

Title: Spurious Emissions at TX antenna
Comment A: FCC ID: AS5CMP-44. Flexant CDMA MicroMini Cell (duplex)
Channel 16. Power= 24 Watts.
Date: 10.NOV.2000 15:04:56



Ref Lvl
43.8 dBm

RBW 30 kHz RF Att 30 dB
VBW 300 kHz
SWT 14 s Unit dBm

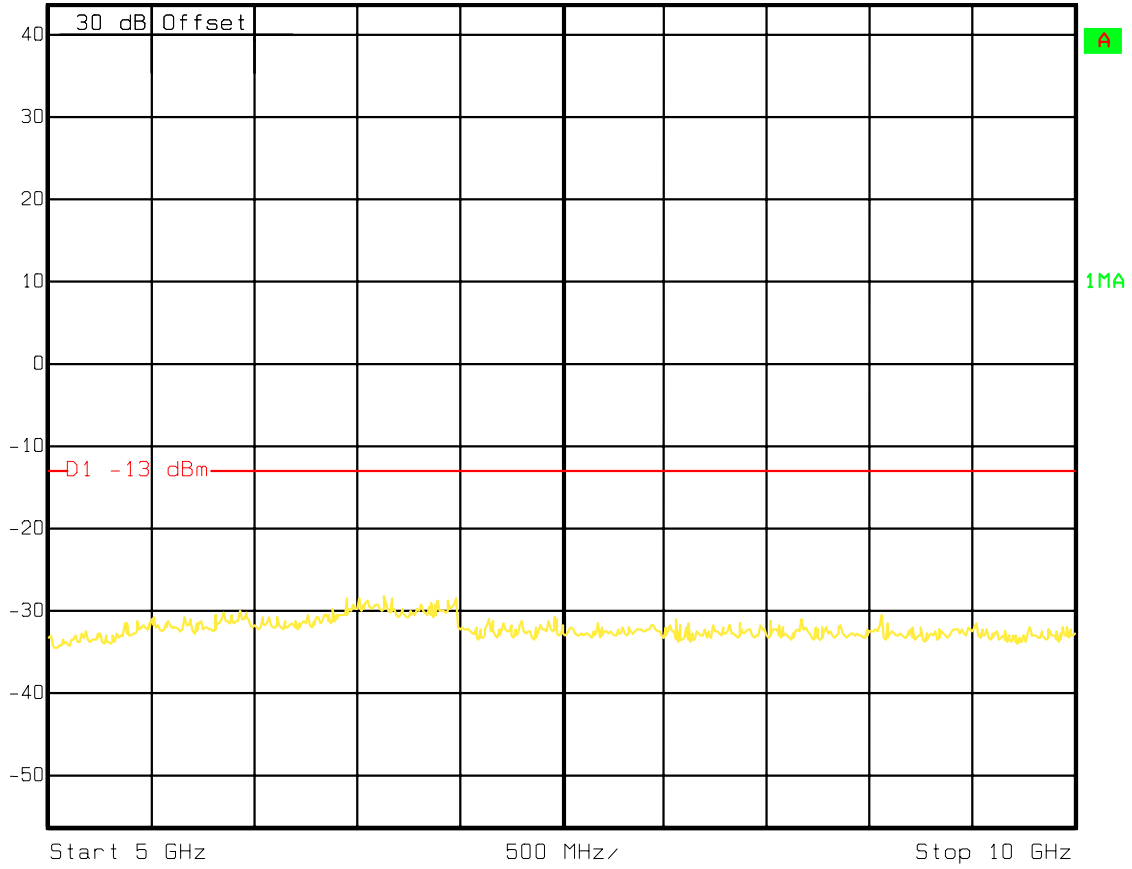

Title: Spurious Emissions at TX antenna
Comment A: FCC ID: AS5CMP-44. Flexant CDMA MicroMini Cell (duplex)
Channel 16. Power= 24 Watts.
Date: 10.NOV.2000 15:03:48



Ref Lvl
43.8 dBm

RBW 30 kHz RF Att 30 dB
VBW 300 kHz
SWT 500 ms Unit dBm

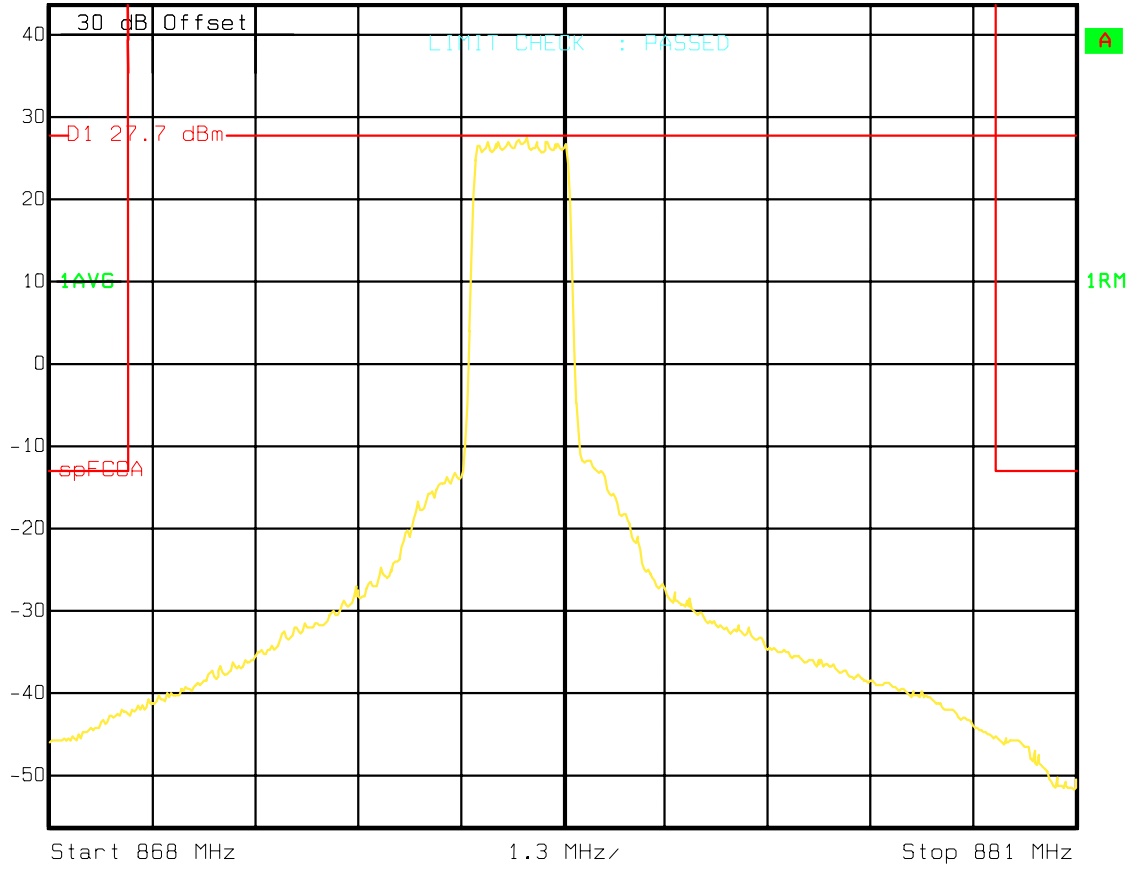

Title: Spurious Emissions at TX antenna
Comment A: FCC ID: AS5CMP-44. Flexant CDMA MicroMini Cell (duplex)
Channel 133. Power= 24 Watts.
Date: 10.NOV.2000 16:31:37



Ref Lvl
43.8 dBm

RBW 30 kHz RF Att 30 dB
VBW 300 kHz
SWT 2.8 s Unit dBm

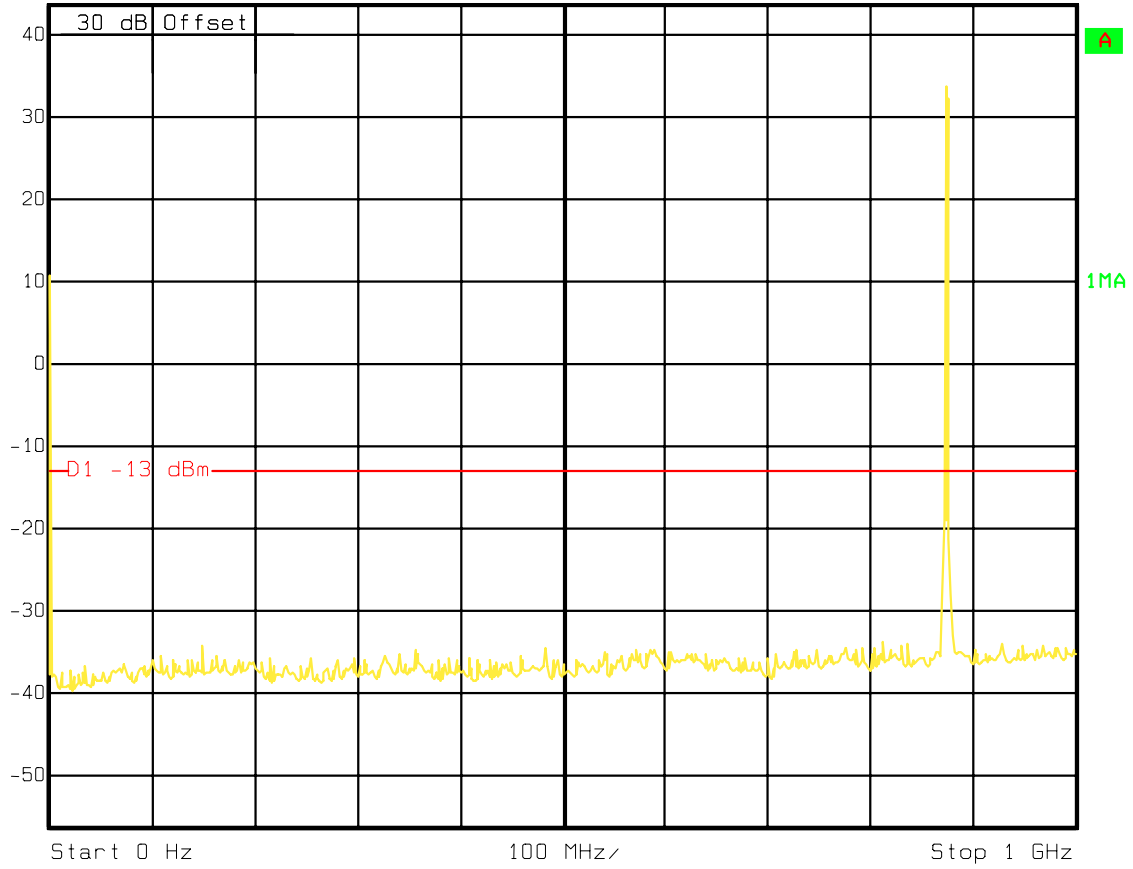

Title: Spurious Emissions at TX antenna
Comment A: FCC ID: AS5CMP-44. Flexant CDMA MicroMini Cell (duplex)
Channel 133. Power= 24 Watts.
Date: 10.NOV.2000 16:37:57



Ref Lvl
43.8 dBm

RBW 30 kHz RF Att 30 dB
VBW 300 kHz
SWT 11.5 s Unit dBm

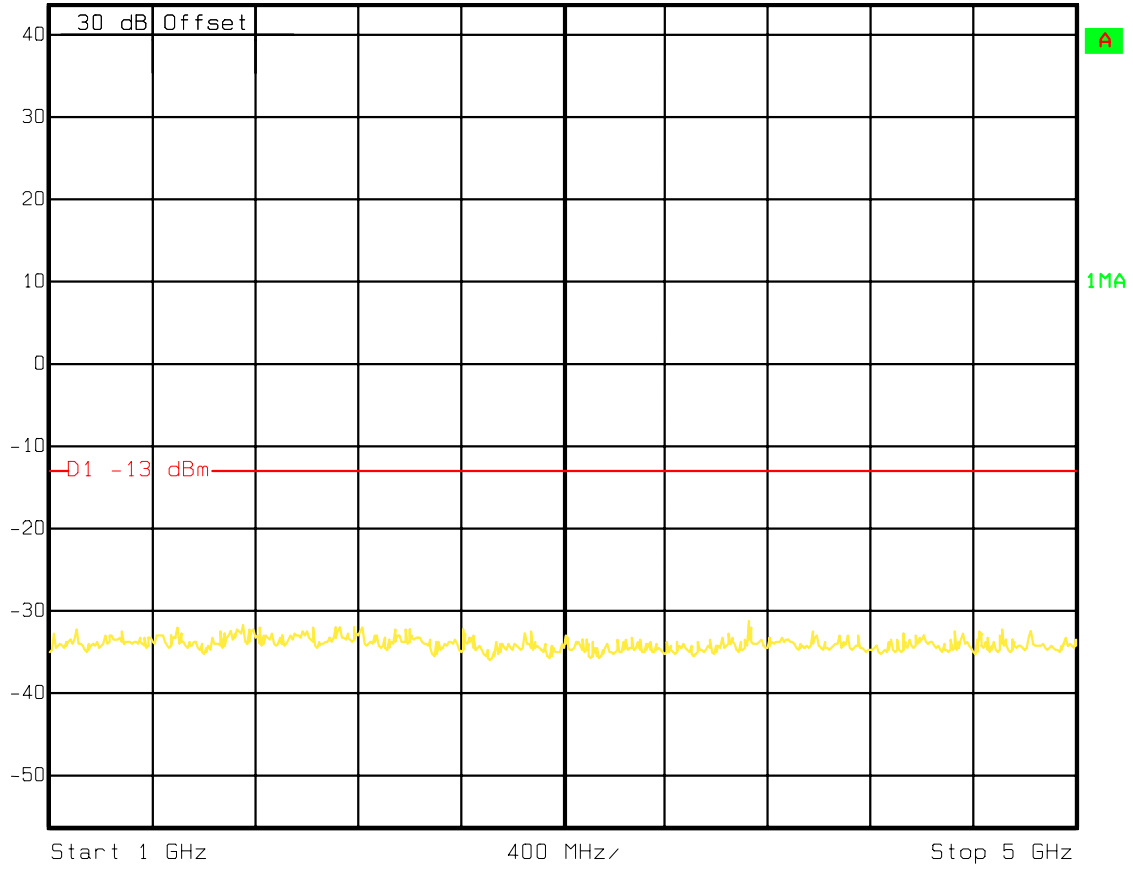

Title: Spurious Emissions at TX antenna
Comment A: FCC ID: AS5CMP-44. Flexant CDMA MicroMini Cell (duplex)
Channel 133. Power= 24 Watts.
Date: 10.NOV.2000 16:36:47



Ref Lvl
43.8 dBm

RBW 30 kHz RF Att 30 dB
VBW 300 kHz
SWT 14 s Unit dBm

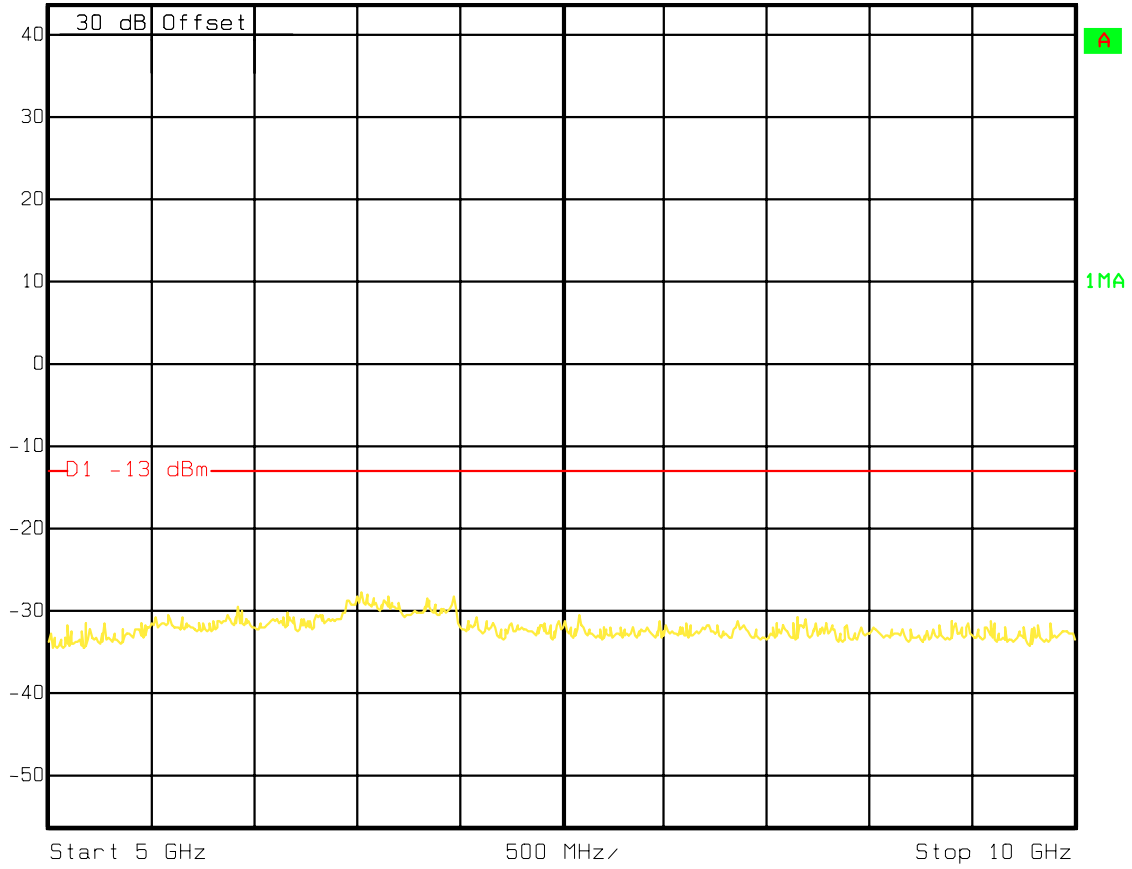

Title: Spurious Emissions at TX antenna
Comment A: FCC ID: AS5CMP-44. Flexant CDMA MicroMini Cell (duplex)
Channel 133. Power= 24 Watts.
Date: 10.NOV.2000 16:39:12



Ref Lvl
43.8 dBm

RBW 30 kHz RF Att 30 dB
VBW 300 kHz
SWT 500 ms Unit dBm

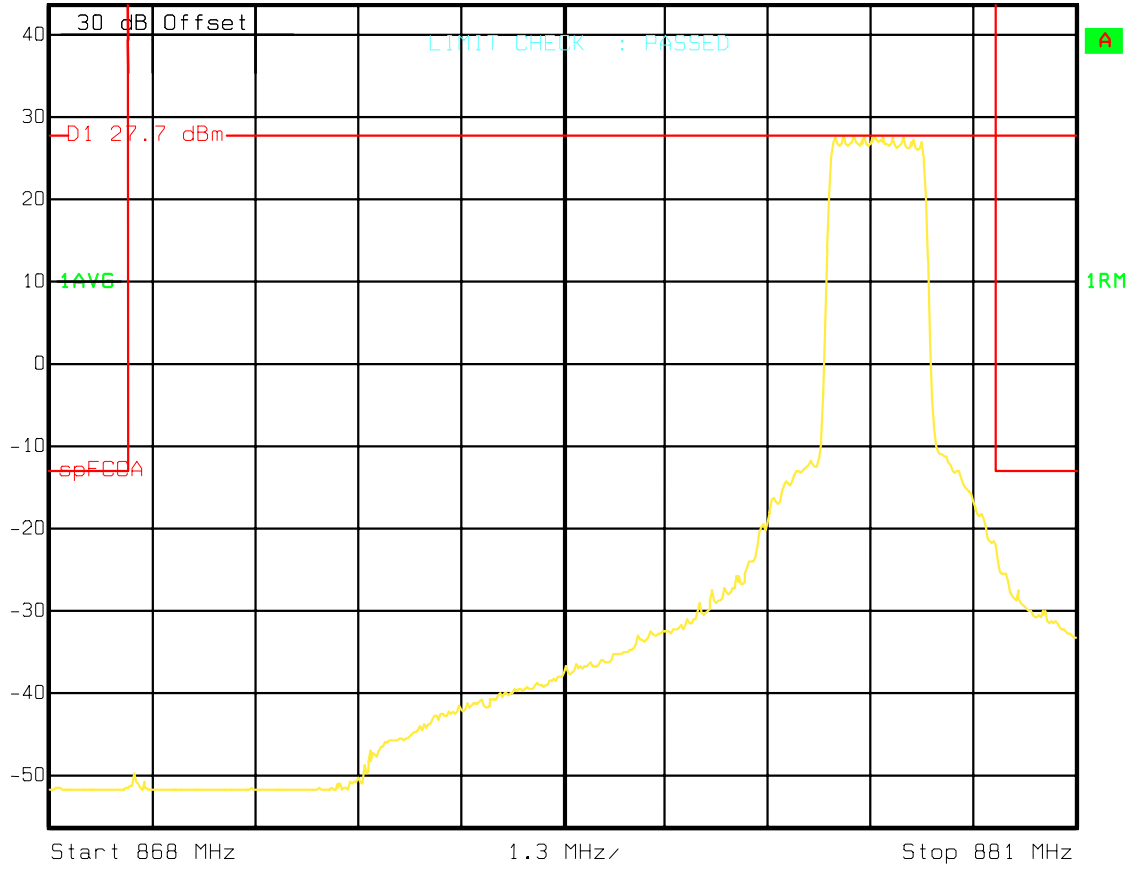

Title: Spurious Emissions at TX antenna
Comment A: FCC ID: AS5CMP-44. Flexant CDMA MicroMini Cell (duplex)
Channel 283. Power= 24 Watts.
Date: 10.NOV.2000 16:50:27



Ref Lvl
43.8 dBm

RBW 30 kHz RF Att 30 dB
VBW 300 kHz
SWT 2.8 s Unit dBm

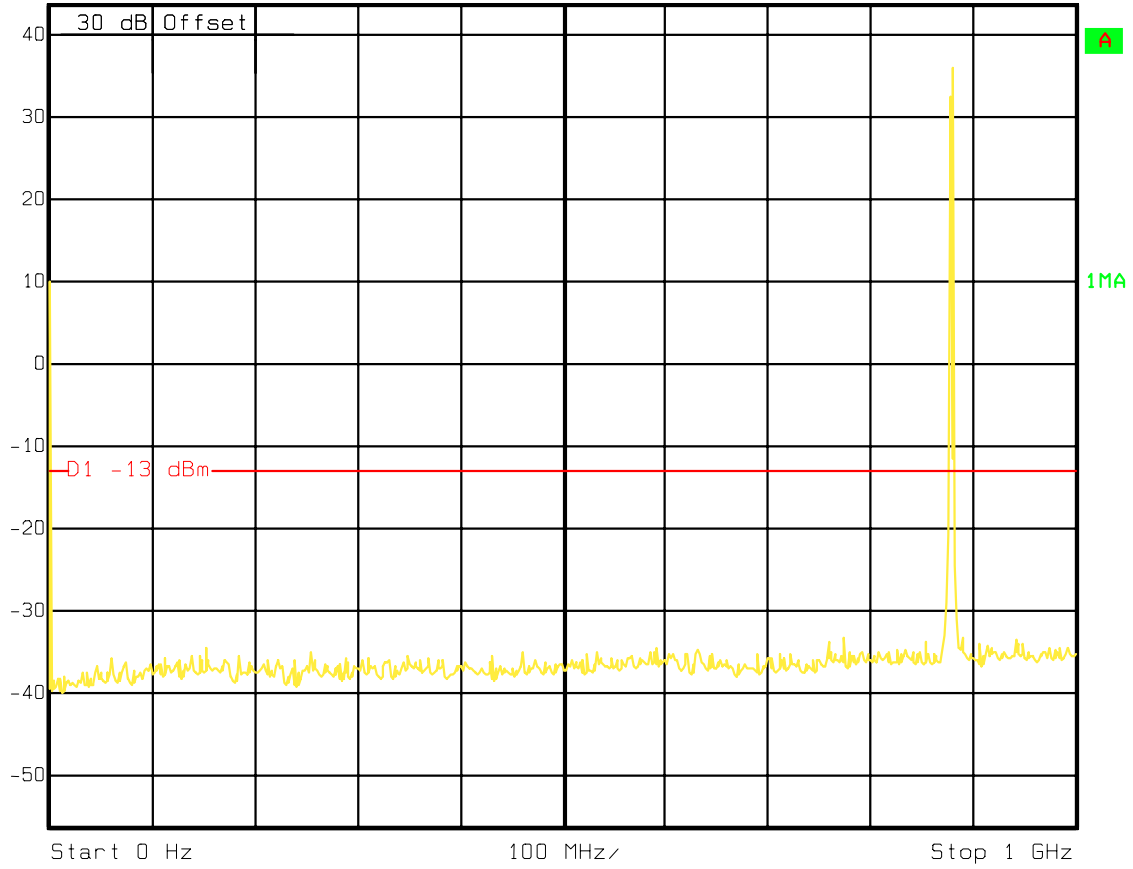

Title: Spurious Emissions at TX antenna
Comment A: FCC ID: AS5CMP-44. Flexant CDMA MicroMini Cell (duplex)
Channel 283. Power= 24 Watts.
Date: 10.NOV.2000 16:43:50



Ref Lvl
43.8 dBm

RBW 30 kHz RF Att 30 dB
VBW 300 kHz
SWT 11.5 s Unit dBm

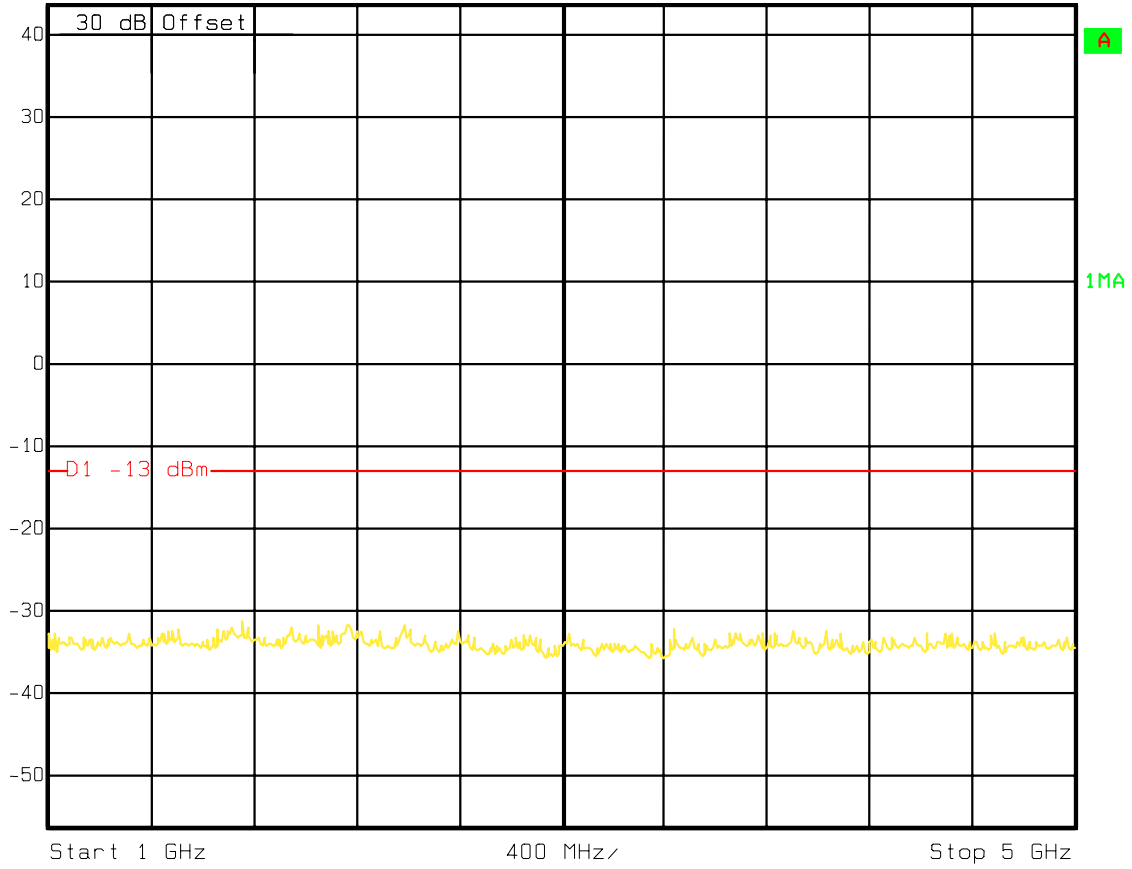

Title: Spurious Emissions at TX antenna
Comment A: FCC ID: AS5CMP-44. Flexant CDMA MicroMini Cell (duplex)
Channel 283. Power= 24 Watts.
Date: 10.NOV.2000 16:44:57



Ref Lvl
43.8 dBm

RBW 30 kHz RF Att 30 dB
VBW 300 kHz
SWT 14 s Unit dBm

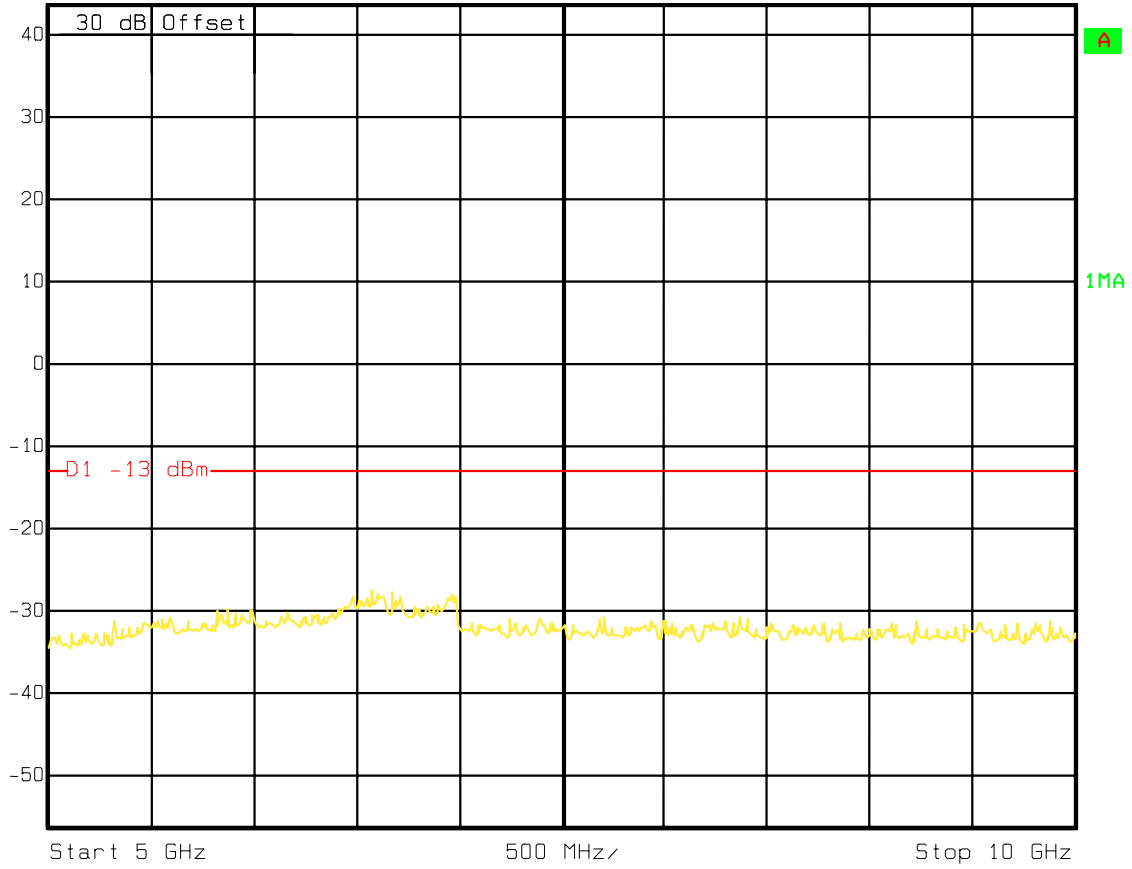

Title: Spurious Emissions at TX antenna
Comment A: FCC ID: AS5CMP-44. Flexant CDMA MicroMini Cell (duplex)
Channel 283. Power= 24 Watts.
Date: 10.NOV.2000 16:46:09

MEASUREMENT: 4

MEASUREMENT

OF

ANTENNA CONDUCTED SPURIOUS

BLOCK B

(880-890 MHz)

Left Edge:	881.52 MHz (Channel 384)
Center:	885.00 MHz (Channel 500)
Right Edge:	888.51 MHz (Channel 617)



Ref Lvl
43.8 dBm

RBW 30 kHz RF Att 30 dB
VBW 300 kHz
SWT 500 ms Unit dBm

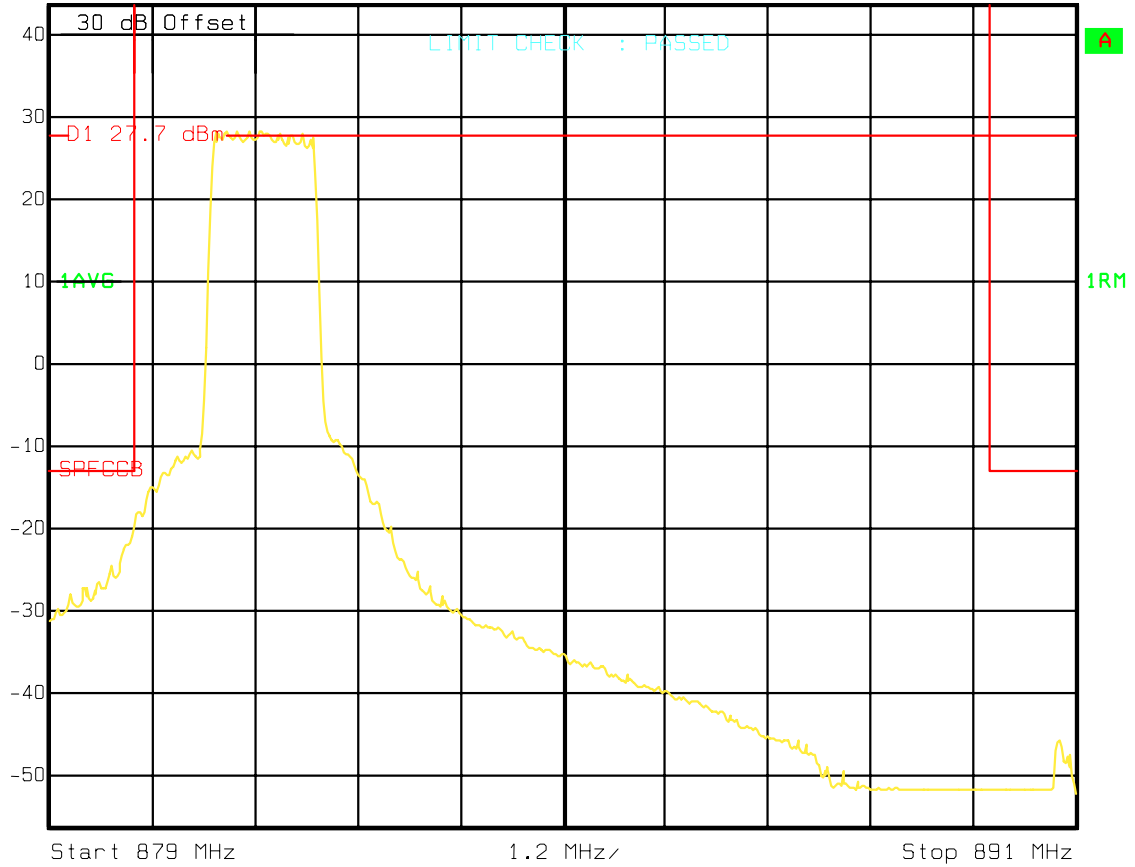

Title: Spurious Emissions at TX antenna
Comment A: FCC ID: AS5CMP-44. Flexant CDMA MicroMini Cell Channel 384.
Output Power= 24Watts.
Date: 13.NOV.2000 16:05:03



Ref Lvl
43.8 dBm

RBW 30 kHz RF Att 30 dB
VBW 300 kHz
SWT 2.8 s Unit dBm

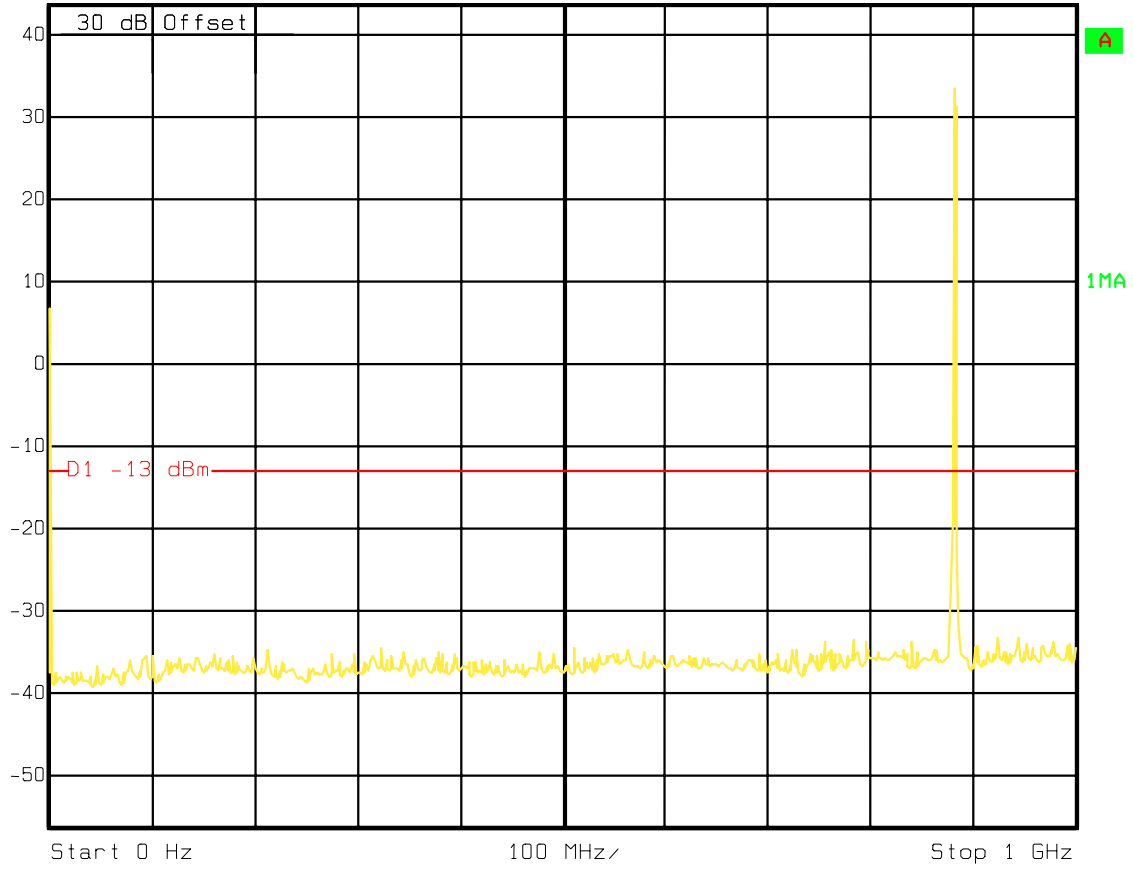

Title: Spurious Emissions at TX antenna
Comment A: FCC ID: AS5CMP-44. Flexant CDMA MicroMini Cell Channel 384.
Output Power= 24Watts.
Date: 13.NOV.2000 16:09:13



Ref Lvl
43.8 dBm

RBW 30 kHz RF Att 30 dB
VBW 300 kHz
SWT 11.5 s Unit dBm

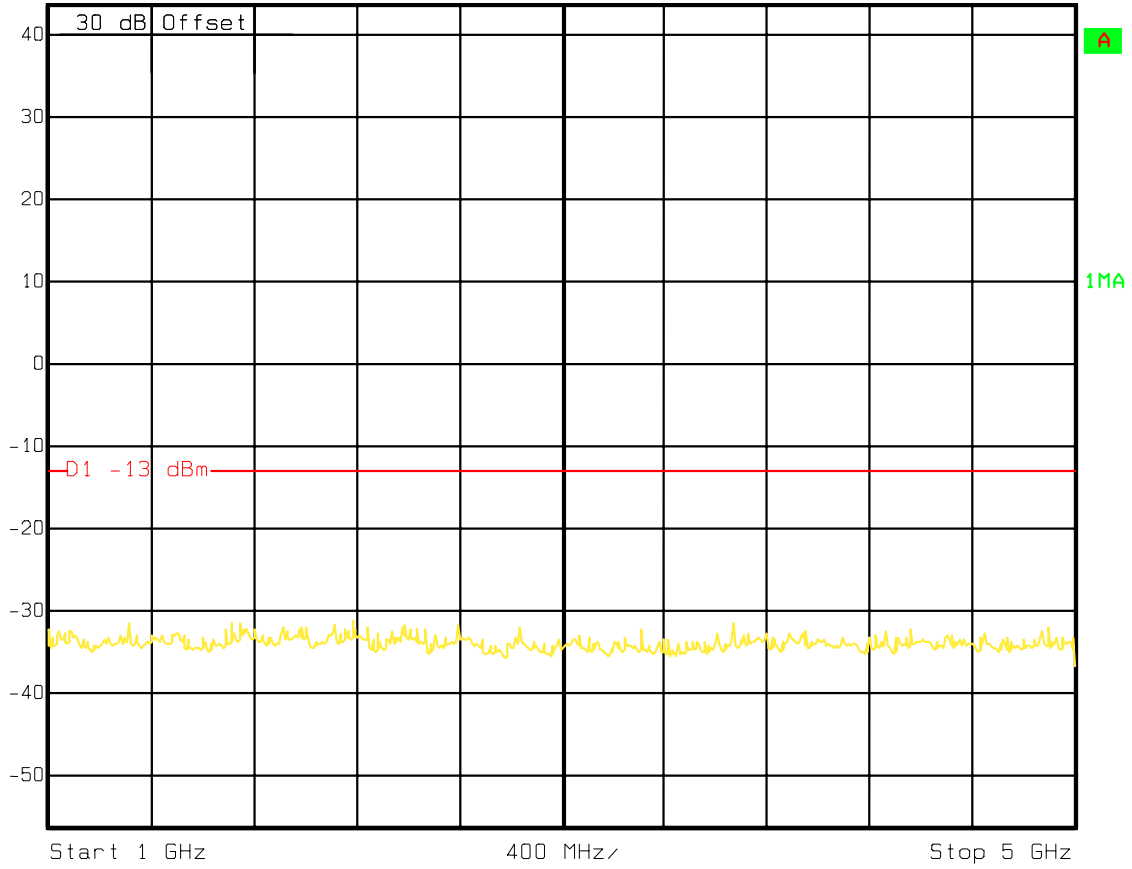

Title: Spurious Emissions at TX antenna
Comment A: FCC ID: AS5CMP-44. Flexant CDMA MicroMini Cell Channel 384.
Output Power= 24Watts.
Date: 13.NOV.2000 16:10:52



Ref Lvl
43.8 dBm

RBW 30 kHz RF Att 30 dB
VBW 300 kHz
SWT 14 s Unit dBm

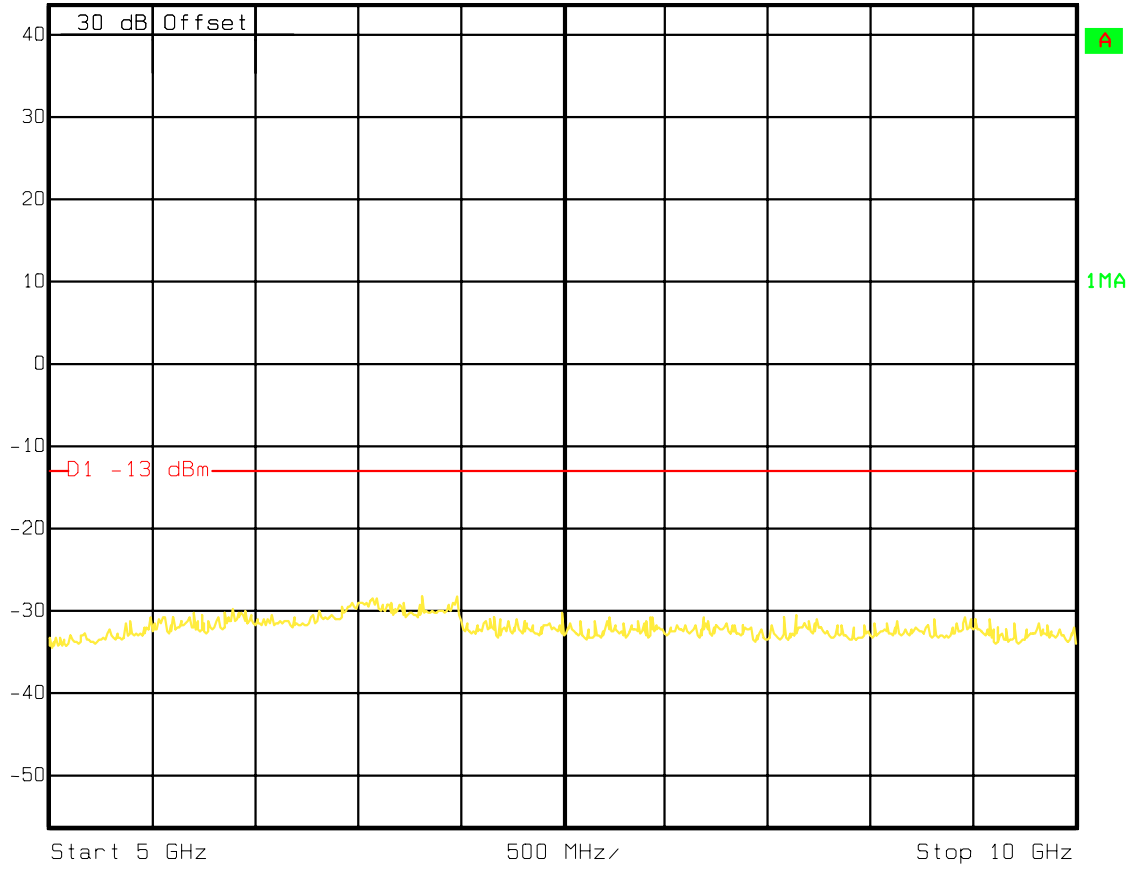

Title: Spurious Emissions at TX antenna
Comment A: FCC ID: AS5CMP-44. Flexant CDMA MicroMini Cell Channel 384.
Output Power= 24Watts.
Date: 13.NOV.2000 16:12:08



Ref Lvl
43.8 dBm

RBW 30 kHz RF Att 30 dB
VBW 300 kHz
SWT 500 ms Unit dBm

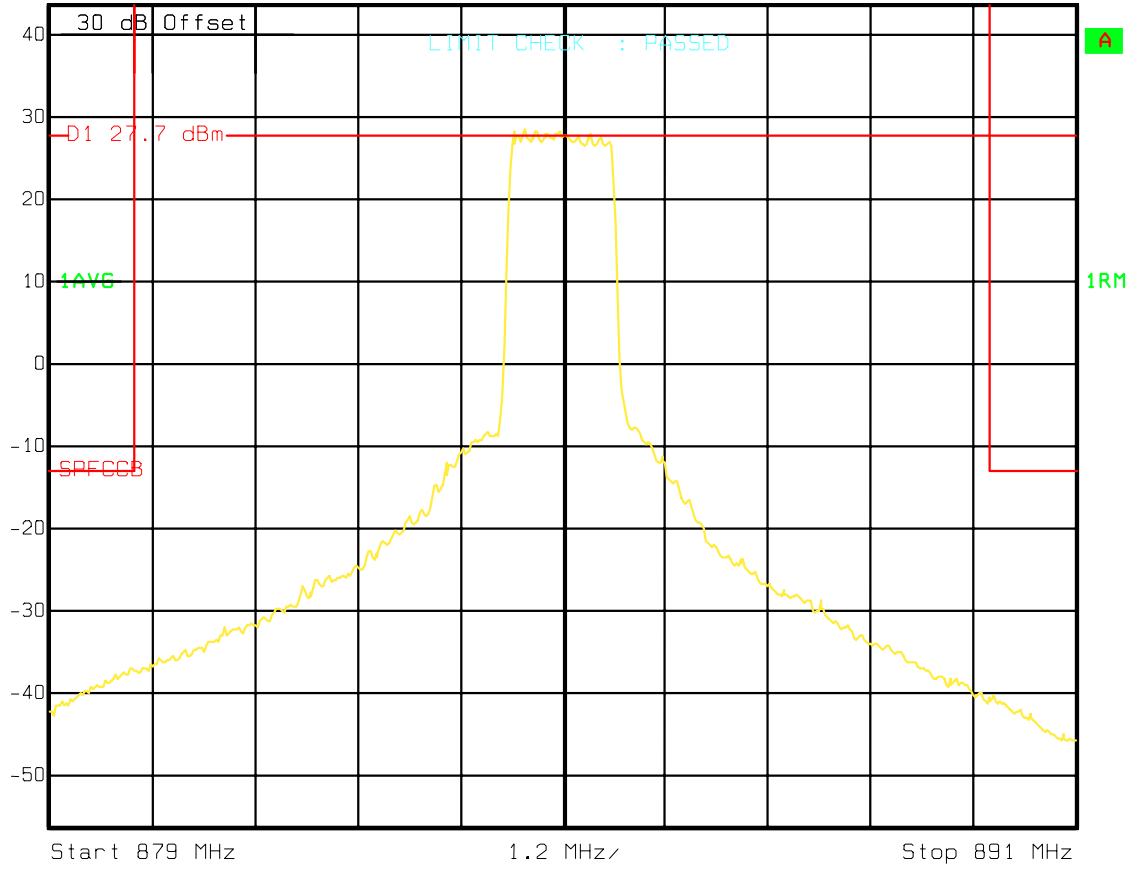

Title: Spurious Emissions at TX antenna
Comment A: FCC ID: AS5CMP-44. Flexant CDMA MicroMini Cell Channel 500.
Output Power= 24Watts.
Date: 13.NOV.2000 16:22:04



Ref Lvl
43.8 dBm

RBW 30 kHz RF Att 30 dB
VBW 300 kHz
SWT 2.8 s Unit dBm

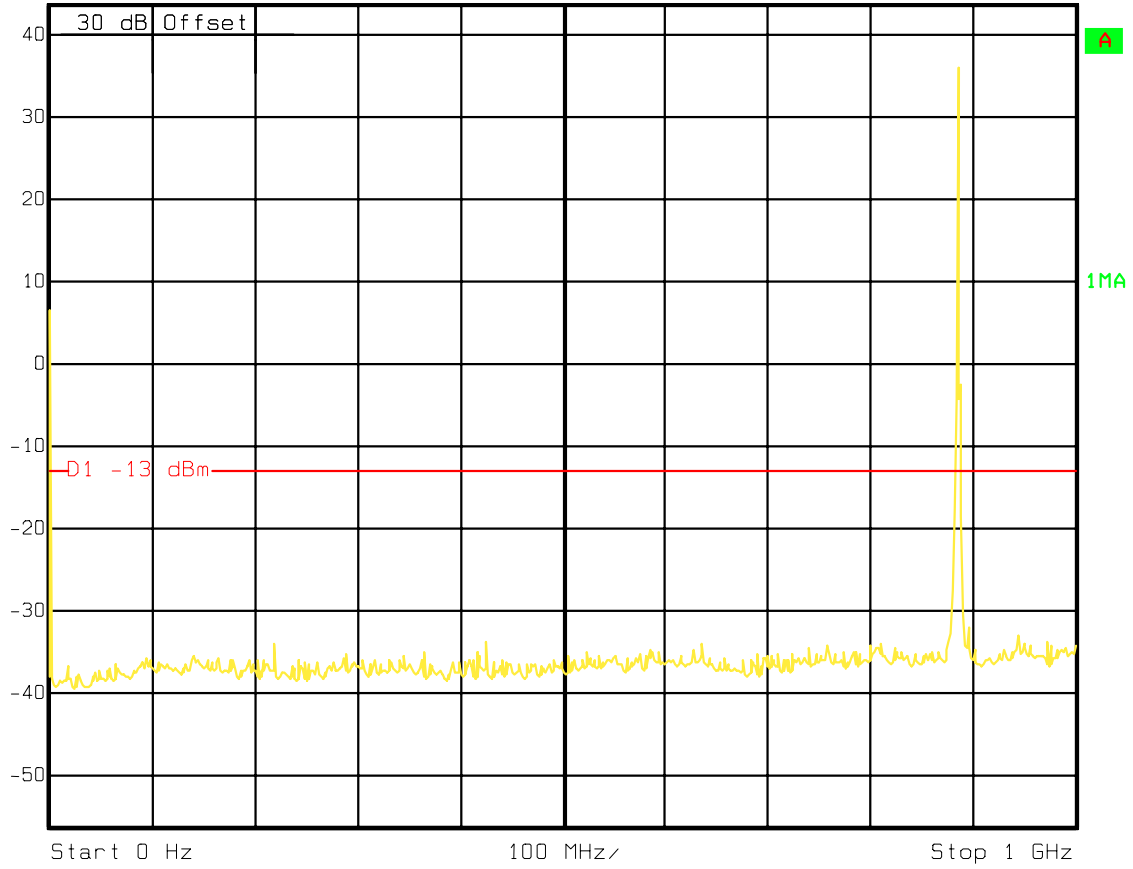

Title: Spurious Emissions at TX antenna
Comment A: FCC ID: AS5CMP-44. Flexant CDMA MicroMini Cell Channel 500.
Output Power= 24Watts.
Date: 13.NOV.2000 16:19:48



Ref Lvl
43.8 dBm

RBW 30 kHz RF Att 30 dB
VBW 300 kHz
SWT 11.5 s Unit dBm

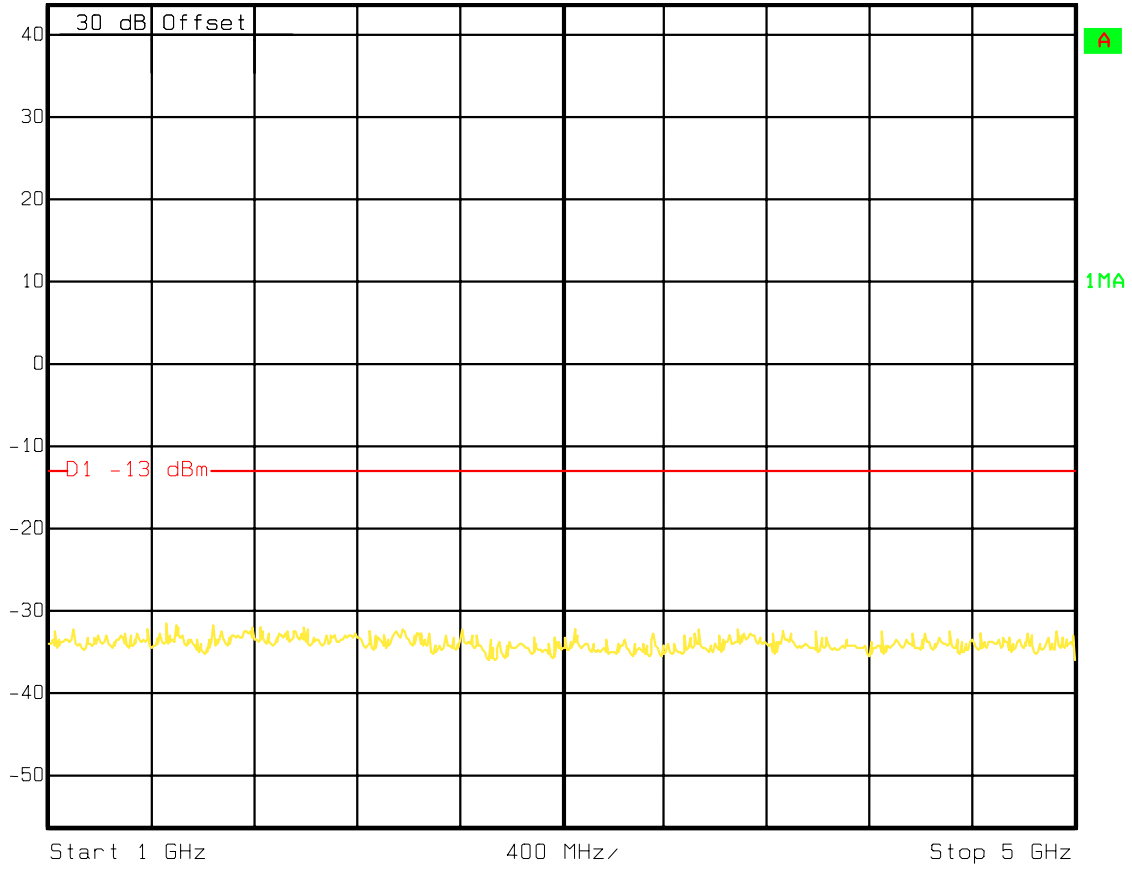

Title: Spurious Emissions at TX antenna
Comment A: FCC ID: AS5CMP-44. Flexant CDMA MicroMini Cell Channel 500.
Output Power= 24Watts.
Date: 13.NOV.2000 16:18:57



Ref Lvl
43.8 dBm

RBW 30 kHz RF Att 30 dB
VBW 300 kHz
SWT 14 s Unit dBm

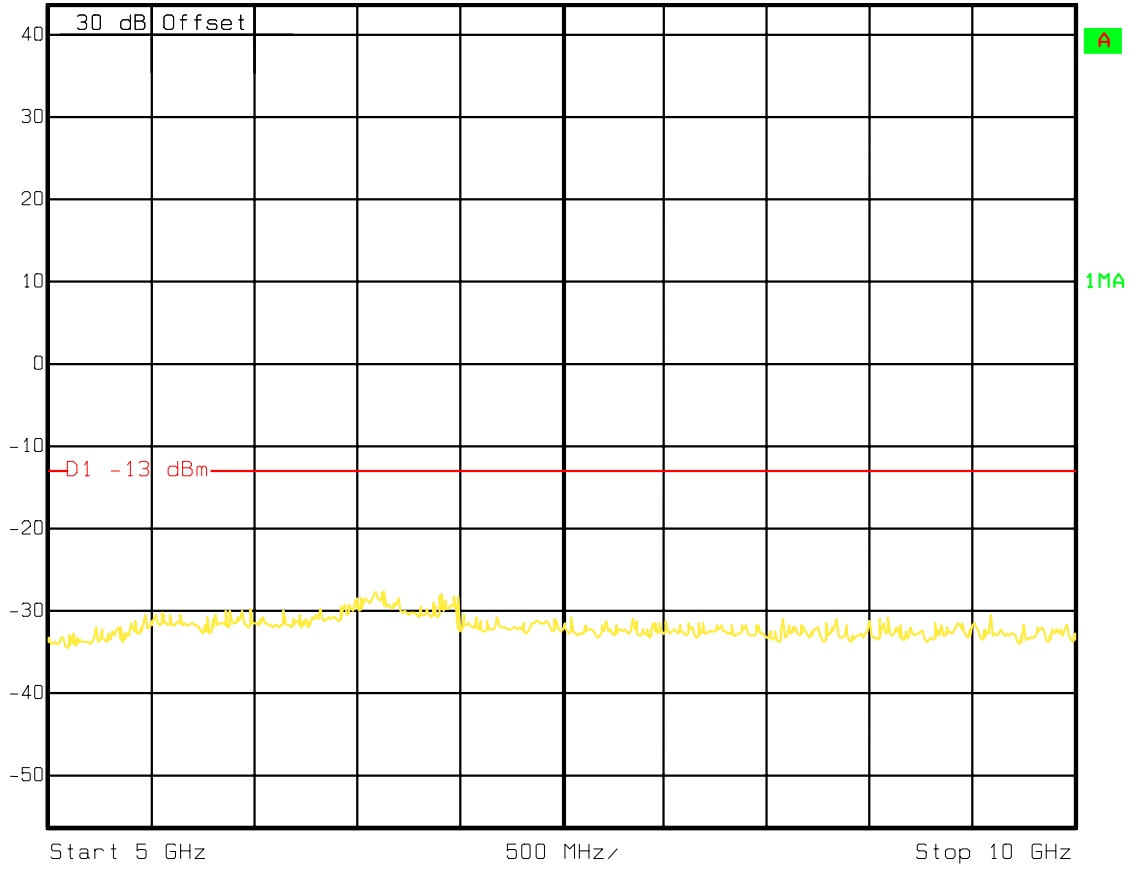

Title: Spurious Emissions at TX antenna
Comment A: FCC ID: AS5CMP-44. Flexant CDMA MicroMini Cell Channel 500.
Output Power= 24Watts.
Date: 13.NOV.2000 16:17:36



Ref Lvl
43.8 dBm

RBW 30 kHz RF Att 30 dB
VBW 300 kHz
SWT 500 ms Unit dBm

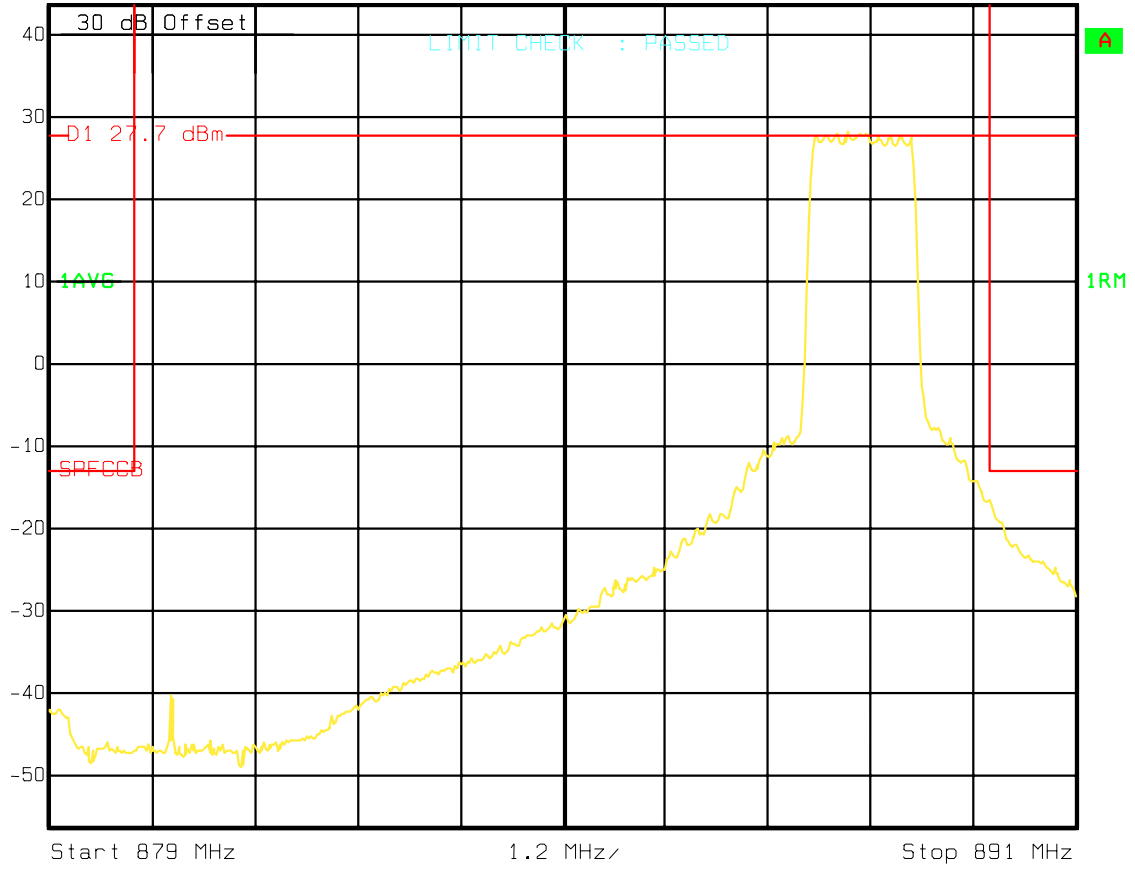

Title: Spurious Emissions at TX antenna
Comment A: FCC ID: AS5CMP-44. Flexant CDMA MicroMini Cell Channel 617.
Output Power= 24Watts.
Date: 13.NOV.2000 16:25:27



Ref Lvl
43.8 dBm

RBW 30 kHz RF Att 30 dB
VBW 300 kHz
SWT 2.8 s Unit dBm

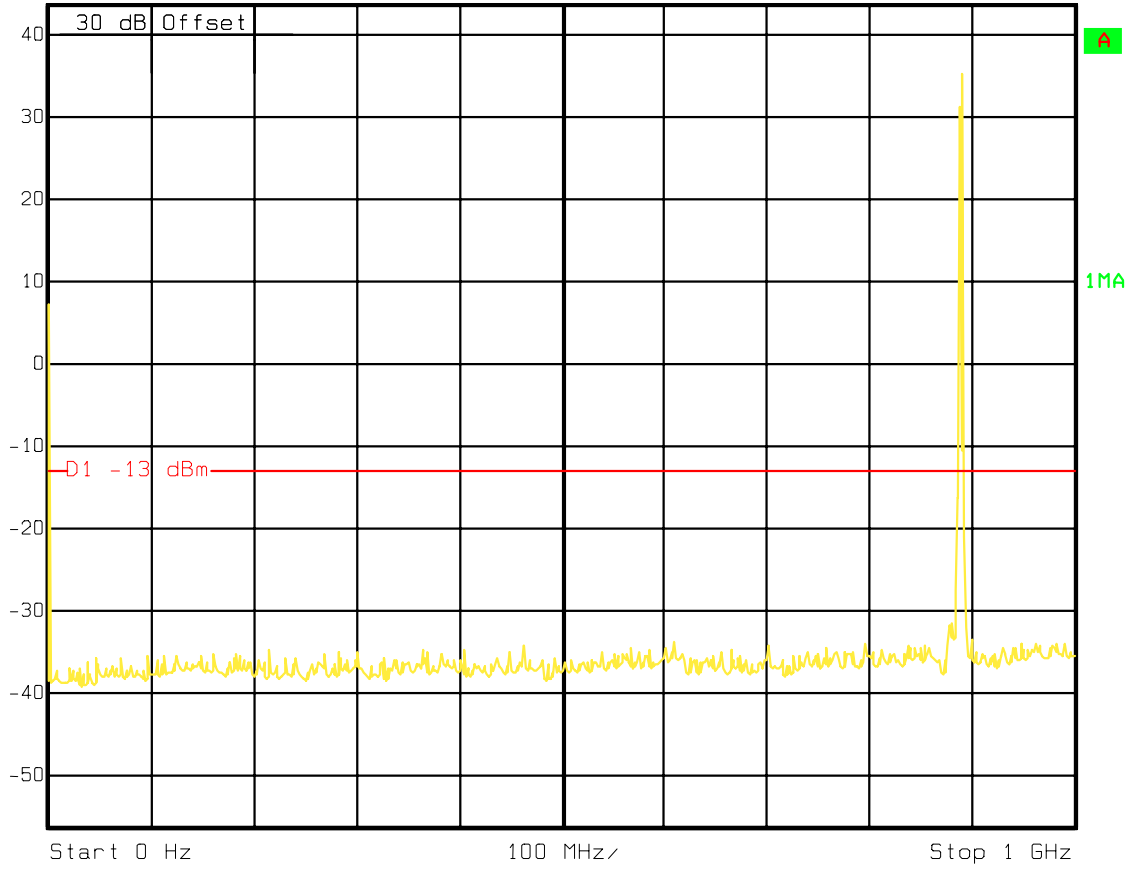

Title: Spurious Emissions at TX antenna
Comment A: FCC ID: AS5CMP-44. Flexant CDMA MicroMini Cell Channel 617.
Output Power= 24Watts.
Date: 13.NOV.2000 16:26:59



Ref Lvl
43.8 dBm

RBW 30 kHz RF Att 30 dB
VBW 300 kHz
SWT 11.5 s Unit dBm

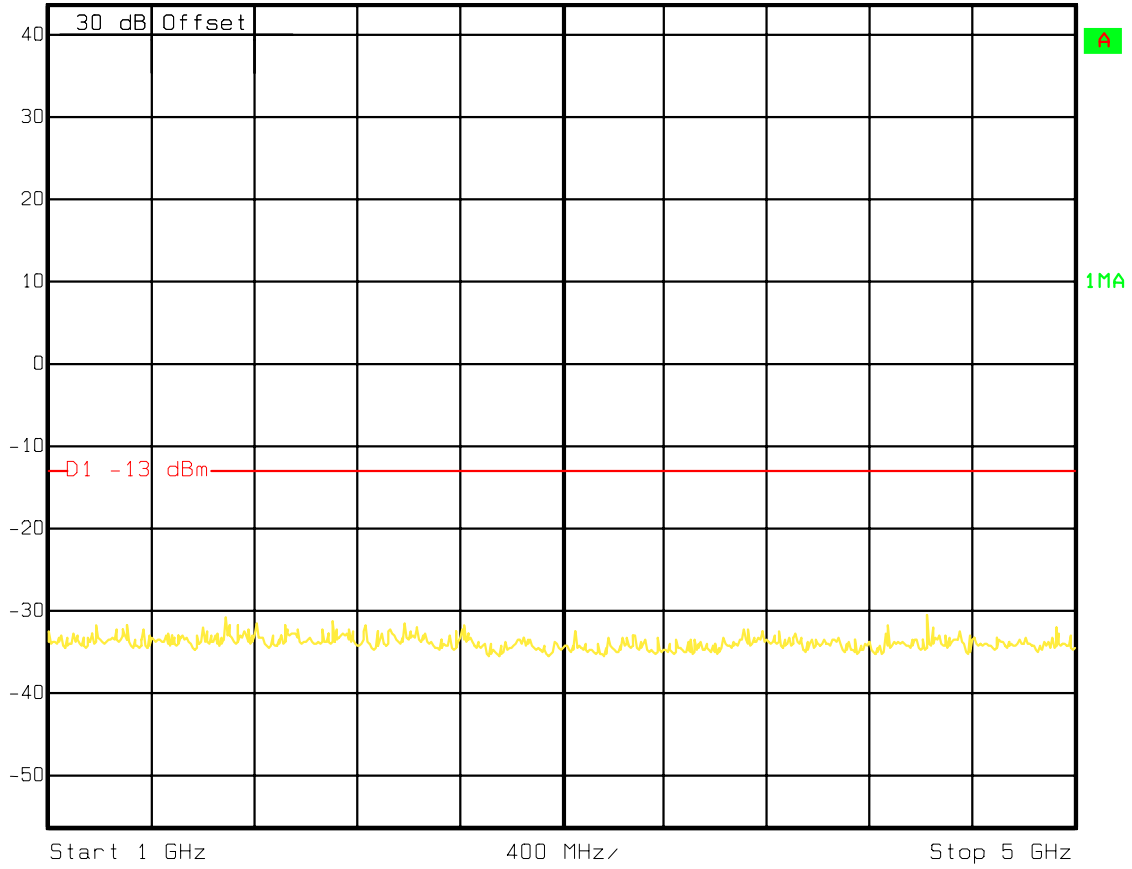

Title: Spurious Emissions at TX antenna
Comment A: FCC ID: AS5CMP-44. Flexant CDMA MicroMini Cell Channel 617.
Output Power= 24Watts.
Date: 13.NOV.2000 16:28:16



Ref Lvl
43.8 dBm

RBW 30 kHz RF Att 30 dB
VBW 300 kHz
SWT 14 s Unit dBm

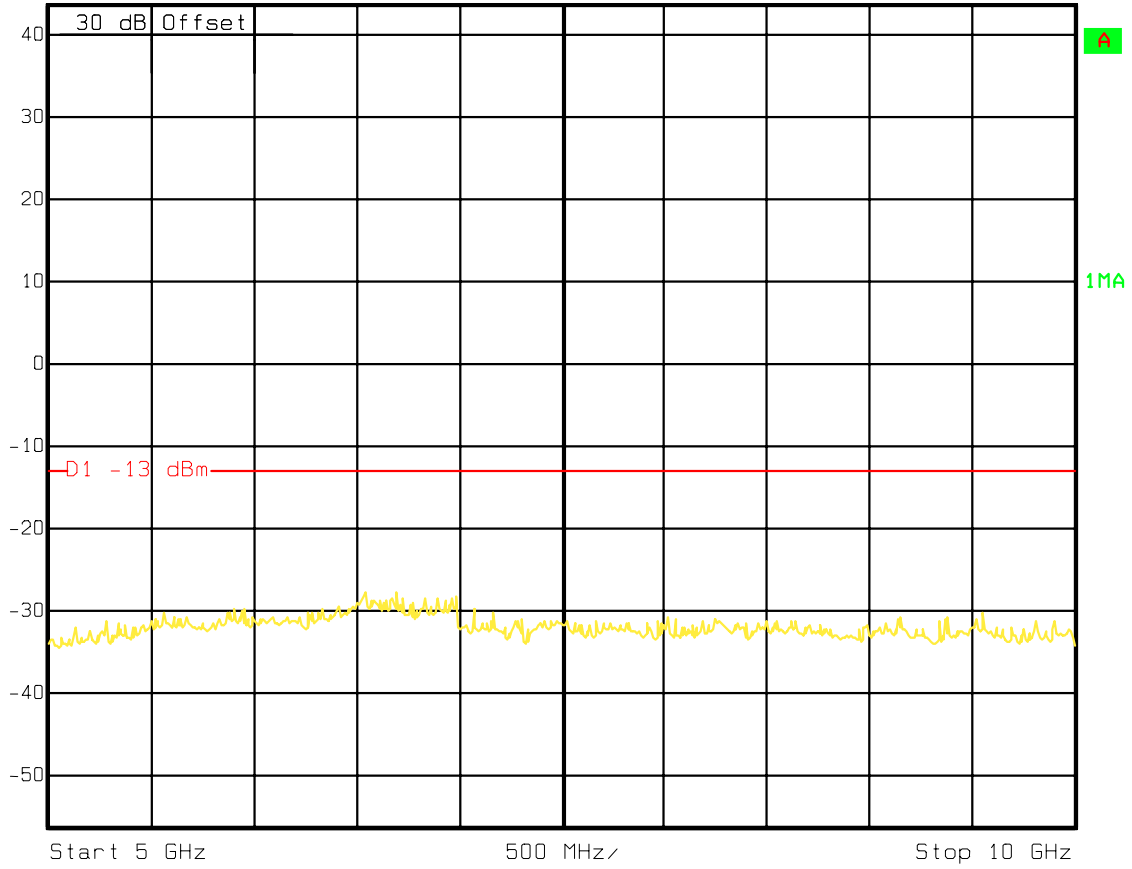

Title: Spurious Emissions at TX antenna
Comment A: FCC ID: AS5CMP-44. Flexant CDMA MicroMini Cell Channel 617.
Output Power= 24Watts.
Date: 13.NOV.2000 16:29:22