

Exhibit 14

SECTION 2.1049 MEASUREMENT OF OCCUPIED BANDWIDTH

Because of the Multi Carrier application of the **ULAM**, occupied bandwidth measurements were performed for all three of the **MCA** configurations. This documents the typical performance of the **ULAM** while supplied with single, dual and three CDMA carriers. Since the **ULAM** is a fixed gain device all power adjustments were performed via the **CBR-850 / FCC ID: AS5CMP-28**.

The Modular Cell system divides the Cellular Bands into Sub-Blocks of one two or three carriers. The edge of each of these Sub-Blocks are evaluated to the edge of band requirements and are compliant. The A Band filters count upward from right to left. While the B Band Sub-Block filters count upward from left to right.

The occupied bandwidth of the **ULAM/ FCC ID: AS5CMP-35** was measured using a Rohde & Schwarz ESMI EMI Test Receiver and a HP Model 7470A Plotter. The RF power level was measured and adjusted via the test setup in Figure 14A. The calibrated RF output from the transmitter was reduced (to an amplitude usable by the spectrum analyzer) by using a calibrated attenuator. This attenuation was offset on the display and the signal adjusted to the -16.2 dBc level corresponding to the corrected RF power level for a 30 kHz resolution bandwidth. The power calibration was individually verified at each carrier for a 1.23 MHz resolution bandwidth. This value corresponds to the top of the Occupied Bandwidth mask. The top of the mask accurately corresponds to the specified power of 30 watts per carrier / 44.8 dBm. All of the plots are presented with a 7.5 MHz span and the center frequency of the specific Sub-Block of interest. This allows for ease of comparison of the single, dual and three carrier performance. This data is recorded on the Occupied Bandwidth Data Sheets for "Left edge", and "Right Edge" channels for each frequency Band / Sub-Block.

For Cellular Band A, the Sub-Block filter A1 is for the "Right Edge of Block" and is designed for as many as three carriers. Likewise the Sub-Block filter A2 is also for three carriers and is placed for the "Left Edge" and will accommodate a maximum of two carrier. Block B is partitioned differently as the B1 Sub-Block filter is for the Left edge of Band. Sub-Block Filters for A1, A2, B1 and B2 are all When operated in the multi-carrier MCA configuration the A1 and B1 Occupied Bandwidth plots present one, two and three center channel performance charts at the respective Left Edge of Block. The A2 and B2 Plots present the typical one, two and three carrier performance at the Left and Right Edge of their respective Bands.

The frequencies and channels used are tabulated on the bottom of each plot. Input and output signals are plotted at each frequency/ channel. Plots are provided for Left Edge, Center and Right Edge of each Cellular Sub-Block evaluated. These frequencies were chosen to show the occupied bandwidth in the channels in each of the Cellular Bands in which this radio can be operated, in compliance with Section 22.917 of the Commission code PN-3383 Section 4.5.1.3.1. There are no SAT or Wide band data signals associated with CDMA. The signal used to show the occupied bandwidth is defined in table 14.1. This is the signal recommended in IS-97. The power output level was adjusted to provide the documented power levels at the bottom of each chart.

The applied signal met the recommended characteristics per PN-3383 Section4.5.1.3.1 as defined below.

Type	Number of Channels	Fraction of Power (Linear)	Fraction of Power (dB)	Comments
Pilot	1	0.1490	-8.3	Walsh 0
Sync	1	0.015/p	-18.3	Walsh 32, always 1/8 rate
Paging	1	0.054	-12.7	Walsh 1, full rate only
Traffic	6	0.13 each	-8.8 each	Variable Walsh Assignments, full rate only

TABLE 14.1 Base Station Test Model, Nominal

Exhibit 14 continued

The minimum standard presented in PN-3383 Section4.5.1.3.1 was followed.

“Suppression Inside the Licensee’s Frequency Block(s)”

For all frequencies within the base station transmit band of 869 – 894 MHz that are within the specific block(s) allocated to the operator's system, the total conducted spurious emissions in any 30kHz band greater than 750 kHz for the CDMA channel center frequency shall not exceed a level of -45 dBc....

Measurement at a Resolution Bandwidth of 30 kHz is based on our experience with Section 22.917 of The Code and lacking other guidance.

The spectrum analysis output plots shows the peak of the CDMA channel signal 16.19 dB below the Mask reference / “zero dBc line” of the spectrum analyzer for the following reason: For the CDMA system there is no carrier without modulation. The following relationship was used to provide the correct level for an unmodulated carrier vs. the modulated signal.

$$10*\log (\text{Resolution Bandwidth}/ \text{Transmit Bandwidth}) = \text{Signal Offset} \tag{1}$$

For the peak of the CDMA signal measured with a resolution bandwidth of 30 kHz the signal offset is:

$$\text{Signal Offset} = 10*\log (30 \text{ kHz} /1.25 \text{ MHz}) = -16.19 \text{ dB}$$

Exhibit 14 continued

Measurement

All of the tolerance lines for the output are referenced to the top of the Occupied Bandwidth mask, which is defined as 44.8 dBm/ zero dBc. For all measurements of the **ULAM / MCA's** Occupied Bandwidth, the output power was measured / adjusted individually to the 30 W level for each carrier and this is the 44.8 dBm value at the 0 dBc reference line.

In order to depict the tolerance lines that are required by Sec 22.917 of the FCC Rules IS-97, all measurements were made with a resolution bandwidth of 30 kHz and the limits were adjusted using equation (1). An average detector was employed using minimum of 25 sweeps per trace.

Mask Description for Single Carrier

The Mask limits are identical for the left and right side of the Cellular Band and are as follows. Figure 14-B shows the Mask limit for Cellular channels 507 548 and 589 which is the left Band edge for B Band. The Spectrum Analyzer reference level is set above the Signal Reference to allow for the necessary dynamic range of a three CDMA carrier presentation. The top of a typical 44.8 dBm single carrier CDMA signal viewed at a resolution bandwidth of 30 kHz is shown at the 27.6 dBm/ -16.2 dBc line. This line is based on equation 1, and the ratio of the 1.25 MHz bandwidth and the 30 kHz resolution bandwidth of the spectrum analyzer. The vertical line from a to b (i.e. a-b) is at 750 kHz from the center of channel 507 (i.e. Fc), per IS-97. The horizontal line b-c is 45 dB below the 44.8 dBm/ 0 dBc reference level. The vertical line c-d is at 1.98 MHz from the center frequency of the left channel. The placement of line d-e is derived from evaluation of the signal and 12.5 kHz resolution bandwidth, using the suggested value in section 22.917 of the rules. The ratio of 30 kHz to 12.5 kHz in equation (1) gives 3.8 dB. Adjusting the tolerance line to reflect this difference puts the -13 dBm limit line at -9.2 dBm or -53.97 dBc below the reference line. Outside the Cellular Band the limit is -73.0 dBc below the 0 dBc / 44.8 dBm reference because the rules require a 1 MHz resolution bandwidth for measurements 1 MHz or greater outside the Cellular band. Again, equation (1) and the ratio of 1 MHz to 1.25 MHz provides this value. The same logic was used in determining the other block and band edge tolerances.

Mask Description for Multiple Carrier

The mask for multiple carriers only adjusts the width of the carrier portion of the mask. For the example given with multiple carriers there would be no adjustments made to the "Left Edge of Block" requirements. The specified "Right Edge Limit" is treated as an expansion of the non Block edge corner **aa** to be the required + 750 kHz from the center of the "right most" channel. The "Right Edge of Block" limits were derived consistently.

Exhibit 14 Continued Test Equipment and Results**Measurement Equipment used in Figure 14A For Measurement of Occupied Bandwidth**

PCS Modular Cell:	Fully Populated PCS Modular Cell
OM 1&2 :	Oscillator Module, 15 MHz Rubidium and Crystal types
CBR: 1-9:	CDMA Baseband Radio (FCC ID: AS5CMP-28)
ULAM: 1-9:	Ultra Linear Amplifier Module (FCC ID: AS5CMP-35)
Transmit Filter:	Cellular Transmit Filter appropriate for the investigated Band
Directional Coupler:	HP 778D and 772D Dual Directional Coupler
Power Meter:	HP E4419A Power Meter with EPC-E18A Power Head
Test Cables:	W.L. Gore; Low loss test cables custom mfg. for Lucent FCC Laboratory
Plotter:	HP Model 7470A Plotter
Printer:	HP Model 4500DN Printer
Attenuators, Variable	HP 8494B and 8495B DC-18 GHz digital attenuators
Attenuators, Fixed	Weinschel Corp DC-18 GHz, various values
Spectrum Analyzer:	Rohde & Schwarz ESMI EMI Test Receiver
Computer Controller:	EG Technology, Custom Mfg for FCC Laboratory Intel™ Pentium II& III, 450 and 550 MHz controllers With TILE™ software

RESULTS: The following exhibits illustrate the spectrums investigated and document compliance.

W. Steve Majkowski NCE

Figure 12A/14A/15A Test Configuration For RF Power, Occupied Bandwidth and Conducted Spurious

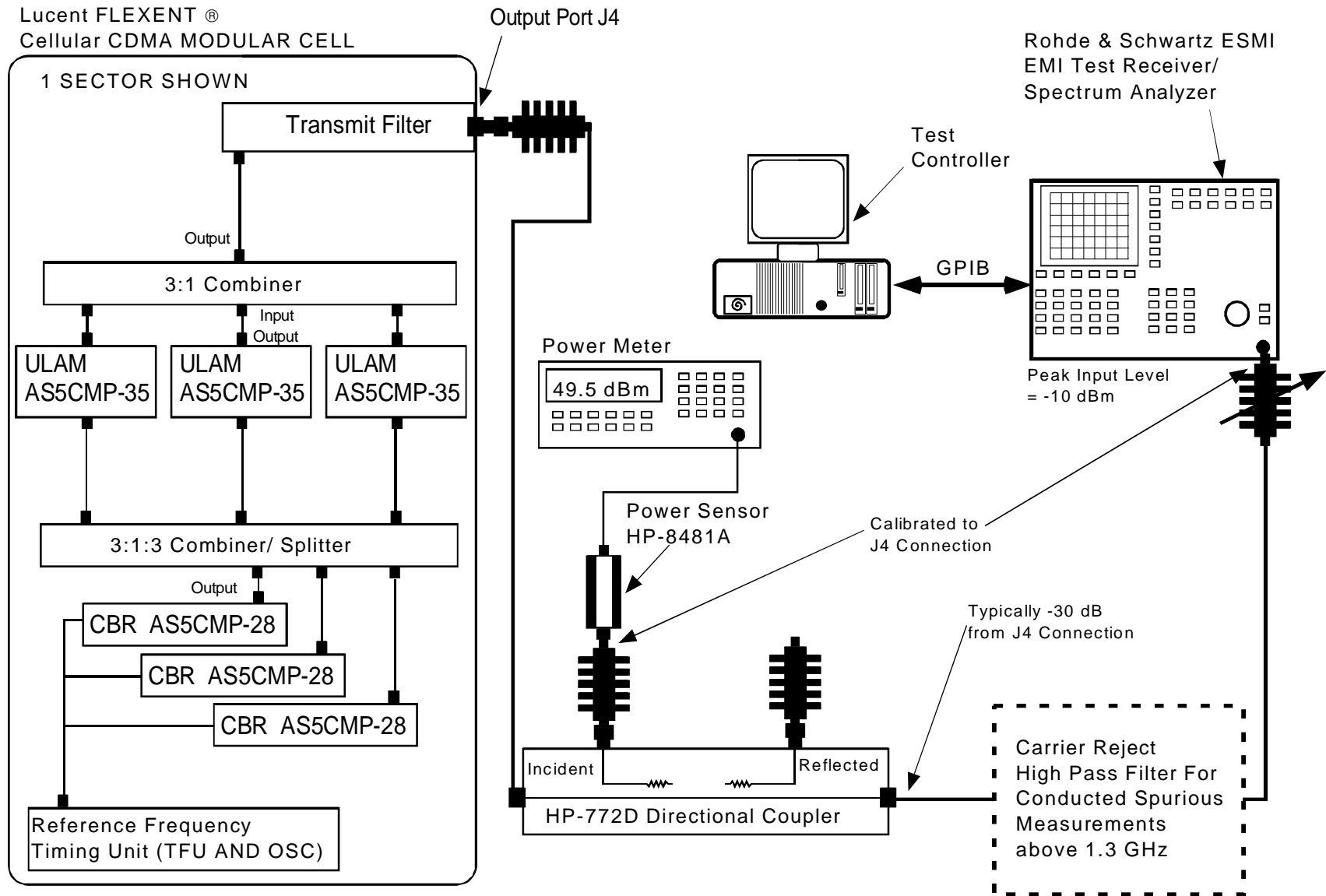

Cellular Modular Cell ULAM
Test Figure WSM 9/28/99

Exhibit 14 Figure 14 B

