

USERS MANUAL
Section 2.1033(C)(3)

USERS MANUAL

SECTION 2.1033(c) (3)

A copy of the installation and operating instructions to be furnished the user. A draft copy of the instructions may be submitted if the actual document is not available. The actual document shall be furnished to FCC when it becomes available.

RESPONSE:

A copy of

(1) LTE Radio Access Network (RAN) - Alcatel-Lucent 9412eNodeB Compact Outdoor-Installation Manual is attached

.



Alcatel-Lucent Long Term Evolution (LTE) Radio Access Network (RAN)

Alcatel-Lucent 9412 eNodeB Compact Outdoor
Installation Manual

Legal notice

Alcatel, Lucent, Alcatel-Lucent and the Alcatel-Lucent logo are trademarks of Alcatel-Lucent. All other trademarks are the property of their respective owners.

The information presented is subject to change without notice. Alcatel-Lucent assumes no responsibility for inaccuracies contained herein.

Copyright © 2011 Alcatel-Lucent. All rights reserved.

Contains proprietary/trade secret information which is the property of Alcatel-Lucent and must not be made available to, or copied or used by anyone outside Alcatel-Lucent without its written authorization.

Notice

Every effort was made to ensure that the information in this Information Product (IP) was complete and accurate at the time of printing. However, information is subject to change.

Mandatory customer information

Product conformance statements can be found in Appendix A of this manual.

Contents



About this document

Purpose	ix
---------------	----

1 Safety

Overview	1-1
Structure of safety statements	1-2
Safety - General precautions for installation procedures	1-4
Safety - specific hazards	1-6

2 Product overview

Overview	2-1
Background information	
Overview	2-3
Functional description	2-4

	Physical description	
	Overview	2-6
	9412 cabinet overview (Standard DC cabinets)	2-7
	9412 cabinet overview (-48V DC Distributed cabinet)	2-9
	9412 cabinet overview (AC cabinet)	2-10
	9412 eNodeB overall dimensions	2-12
	EZBFo battery module overview	2-14
	Equipment weights and dimensions	2-16
	Physical interfaces	2-18
3	Tools, materials, and checklist	
	Overview	3-1
	Preparatory information	
	Overview	3-2
	Tools required for installation	3-3
	Torque requirements	3-6
	Physical installation process overview	3-8
	Installation procedure checklist	3-9
	Verify site preparation completed	3-10
4	Transport, mount, and ground cabinet	
	Overview	4-1
	Lifting and moving cabinets	4-2
	Double stack floor stand lifting brackets	4-7
	Install 9412 eNodeB Compact on the floor stand	4-9
	Install 9412 eNodeB Compact on the pole	4-19
	Pole mounting with pole band	4-21
	Install 9412 eNodeB Compact on the wall	4-25

Ground the 9412 eNodeB Compact cabinets and floor stand	4-31
---	------

6 Connect power cables

Overview	6-1
----------------	-----

Connect DC and AC power

Overview	6-2
----------------	-----

Connect DC cables to 9412 eNodeB (+24 VDC and -48 VDC)	6-3
--	-----

Connect DC power between RF and BB cabinet (AC configuration)	6-8
---	-----

Connect DC power between RRH and BB cabinet (Distributed configuration)	6-11
---	------

Route and connect the AC cable	6-13
--------------------------------------	------

7 Finish the installation

Overview	7-1
----------------	-----

GPS jumper cable

Overview	7-2
----------------	-----

Route and connect GPS jumper cable	7-3
--	-----

GPS antenna sharing (optional)	7-5
--------------------------------------	-----

RF jumper cables

Overview 7-9

About jumper cables 7-10

Route and connect RF jumper cables 7-11

Final connections

Overview 7-14

Initial start-up and system test 7-15

Final cabinet installation procedures 7-16

C Product conformance statements

Overview	C-1
Canada	C-2
European Union	C-5
United States	C-9

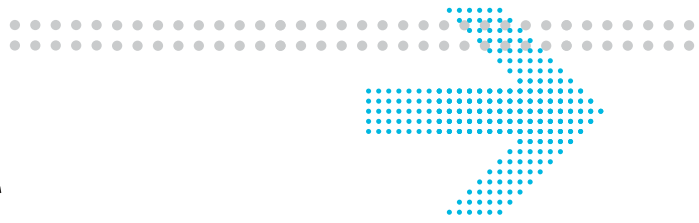

About this document

Purpose

This information product (IP), *Alcatel-Lucent 9412 eNodeB Compact Outdoor Installation Manual*, 418-000-415, provides basic installation guidelines and recommendations. Also, these guidelines are generic. Specific implementations may vary from cell site to cell site.

Procedures are provided for cabinet handling, placement, grounding, powering, and cabling.

If you are unfamiliar with this document, begin with this chapter, then work through the materials in the subsequent chapters. This will help you understand how to use all the provided materials: the installation manual, the job specification, and the cabinet hardware.

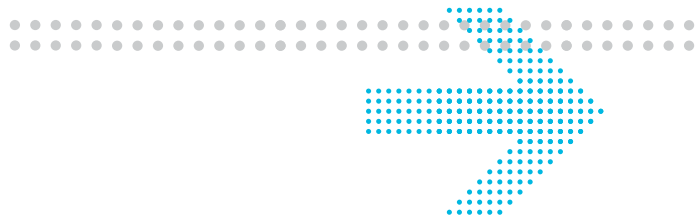

1 Safety

Overview

Purpose

This chapter presents the safety precautions that apply to the product. In regions such as North America and the European Union, the statements that are required are determined primarily by national or multi-national regulations. However, in some regions, contract terms determine which statements are required. The presence of the statement indicates that the product does comply with that statement wherever it is required to do so.

Contents

Structure of safety statements	1-2
Safety - General precautions for installation procedures	1-4
Safety - specific hazards	1-6

Structure of safety statements

Overview

Safety statements describe the safety risks relevant while performing tasks on Alcatel-Lucent products during deployment and/or use. Failure to avoid the hazards may have serious consequences.

General structure

Safety statements include the following structural elements:

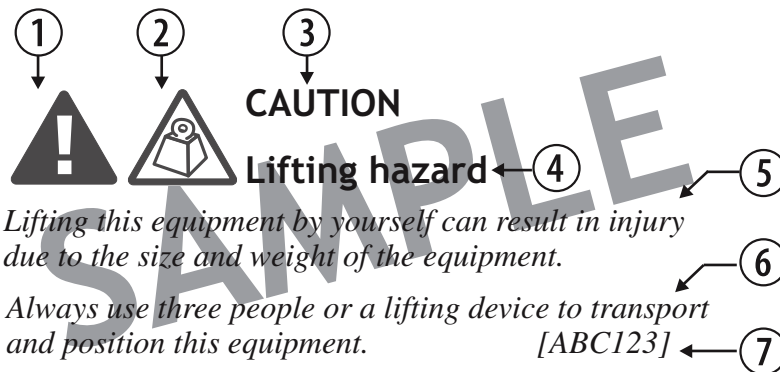

Item	Structure element	Purpose
1	Safety alert symbol	Indicates the potential for personal injury (optional)
2	Safety symbol	Indicates hazard type (optional)
3	Signal word	Indicates the severity of the hazard
4	Hazard type	Describes the source of the risk of damage or injury
5	Safety message	Consequences if protective measures fail
6	Avoidance message	Protective measures to take to avoid the hazard
7	Identifier	The reference ID of the safety statement (optional)

Signal words

The signal words identify the hazard severity levels as follows:

Signal word	Meaning
DANGER	Indicates an extremely hazardous situation which, if not avoided, will result in death or serious injury.
WARNING	Indicates a hazardous situation which, if not avoided, could result in death or serious injury.
CAUTION	Indicates a hazardous situation which, if not avoided, could result in minor or moderate injury.
NOTICE	Indicates a hazardous situation not related to personal injury.

Within this information product, the safety label typically includes additional information such as the hazard type, a description of the damage that can be caused, and the steps that should be taken to avoid the hazard.

Safety - General precautions for installation procedures

Overview

The following general precautions must be observed for installation procedures.

**WARNING****Personal injury**

Failure to observe these safety precautions may result in personal injury or damage to equipment.

To avoid personal injury or damage to equipment, observe the following instructions:

- *Read and understand all instructions.*
- *Follow all warnings and instructions marked on this product.*
- *Installation and maintenance procedures must be followed and performed by trained personnel only.*
- *The equipment must be provided with a readily accessible disconnect device as part of site preparation.*
- *Grounding and circuit continuity is vital for safe operation of the equipment. Never operate the equipment with grounding/bonding conductor disconnected.*
- *Install only equipment identified in the product's installation manual. Use of other equipment may result in an improper connection which could lead to fire or injury.*
- *Use caution when installing or modifying telecommunications lines.*
- *The product has multiple power inputs. Before servicing, Disconnect all inputs to reduce the risk of energy hazards.*
- *For continued protection against risk of fire, all fuses used in this product must be replaced only with fuses of the same type and rating.*
- *Never install telecommunications wiring during a lightning storm.*
- *Never install telecommunications connections in wet locations.*
- *Never touch uninsulated telecommunications wiring or terminals unless the telecommunications line has been disconnected at the interface.*
- *Never push objects of any kind into the product through slots, as they may touch dangerous voltage points or short-out parts that could result in a fire or an electrical short.*
- *Never spill liquids of any kind on the product.*
- *Slots and openings in the product are provided for ventilation. To protect it from overheating, these openings must not be blocked or covered. The product should not be placed in a built-in installation unless proper ventilation is provided.*
- *To reduce the risk of an electrical shock, do not disassemble the product. Opening and removing covers and/or circuit boards may expose you to dangerous voltages or other risks. Incorrect reassembly can cause electrical shock when the unit is subsequently used.*

Safety - specific hazards

Overview

This topic reviews specific hazards for installation.



DANGER

Lightning Strikes!

Lightning strikes are possible during stormy weather, and could result in death or severe injury.

Do not work on the installation itself or on the power supply lines or antenna feeders of a Compact Cell during stormy weather.



WARNING

Energy Hazard!

Some parts of all electrical installations are energized. Failure to observe this fact and the safety warnings may lead to bodily injury and property damage.

For this reason, only trained and qualified personnel (electrical workers as defined in IEC 215 + A1 or EN 60215) may install or service the installation.



WARNING

Energy Hazard!

The power supply lines to the network element are energized. Short circuits can cause burns to the face and hands.

Open the load disconnect switch in the distribution box to completely de-energize the network element.

**WARNING****Beryllium Oxide Poisoning Hazard!**

The transmitter units include components which contain beryllium oxide (BeO). In this form, BeO ceramics do not constitute a hazardous material as long as this material is not destroyed by external mechanical forces.

In the event that repair work is carried out by the customer or by third parties, the following regulations must be observed:

- *Applicable version of the Regulation on Hazardous Materials in the Workplace*
- *Appropriate accident prevention regulations.*

The following must be specifically observed:

- *Do not eat, drink, or smoke in areas where work is taking place on BeO ceramic components.*
- *Wash your hands carefully under running water after working with BeO ceramic components.*

If the following symptoms occur, contact a physician:

- *Irritation of the respiratory organs*
- *Difficulty breathing or skin irritation.*

NOTICE**Condensation may cause a short circuit!**

Sudden changes in the weather may lead to the formation of condensation on components. Operating the unit when condensation moisture is present can destroy the unit.

Units which show signs of condensation must be dried before installation.

NOTICE

Electrostatically Sensitive Components!

Semiconductor elements can be damaged by static discharges.

The following rules must be complied with when handling any module containing semiconductor components:

- *Wear conductive or antistatic work clothes (for example, a coat made of 100% cotton).*
- *Wear grounded ESD wrist strap.*
- *Wear shoes with conductive soles.*
- *Leave the modules in their original packaging until ready for use.*
- *Make sure there is no difference in potential between yourself, the workplace, and the package before removing, unpacking, or packing a module.*
- *Hold the module only by the grip without touching the connection pins, tracks, or components.*
- *Place modules removed from the equipment on a conductive surface.*
- *Test or handle the module only with grounded tools on grounded equipment.*
- *Handle defective modules exactly like new ones to avoid causing further damage.*

NOTICE

Grounding caution!

This equipment has a connection between the grounding conductor of the DC supply circuit and the grounding conductor.

This equipment shall be connected directly to the DC supply system grounding electrode conductor or to a bonding jumper from a grounding terminal bar or bus to which the DC supply system grounding electrode conductor is connected.

This equipment shall be located in the same immediate area (such as, adjacent cabinets) as any other equipment that has a connection between the grounded conductor of the same DC supply circuit and the grounding conductor, and also the point of grounding of the DC system. The DC system shall not be grounded elsewhere.

The DC supply source is to be located within the same premises as the equipment.

There shall be no switching or disconnecting devices in the grounded circuit conductor between the DC source and the point of connection of the grounding electrode conductor.

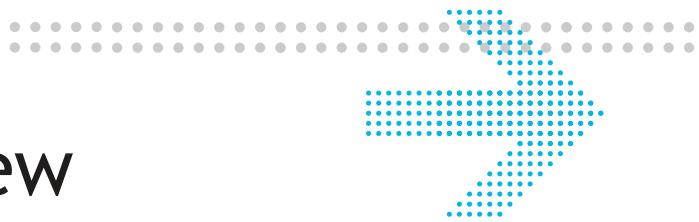

2 Product overview

Overview

Purpose

This chapter describes the 9412 eNodeB outdoor cabinets. This chapter also shows how the eNodeB is used in a wireless network and describes its physical characteristics.

Then the physical characteristics of the eNodeB are discussed -- site requirements, dimensions and weight, and the location of items and components inside the cabinet.

Installation procedures

Before installing the cabinet, the installer should become familiar with the safety precautions, warnings, and product conformance statements. The recommended tools and materials required for installation and the process checklist are listed in [Chapter 3, “Tools, materials, and checklist”](#).

Cabinet installation instructions are covered in [Chapter 4, “Transport, mount, and ground cabinet”](#), which provides instructions for anchoring the cabinet to the floor. After anchoring the cabinet, the cabinet is connected to the network with T1/E1 lines, according to the instructions in [Chapter 5, “Connect interface cables”](#). Instructions for connecting the user and power alarms to the cabinet are provided in [Chapter 5, “Connect interface cables”](#). Instructions for connecting the cabinet to a power source are given in [Chapter 6, “Connect power cables”](#). The eNodeB requires a +24 VDC power source, which can be provided by an external power converter or DC generator.

Instructions for connecting the cabinet to the cell antennas are given in [Chapter 7, “Finish the installation”](#).

Contents

Background information	2-3
Functional description	2-4
Physical description	2-6

9412 cabinet overview (Standard DC cabinets)	2-7
9412 cabinet overview (-48V DC Distributed cabinet)	2-9
9412 cabinet overview (AC cabinet)	2-10
9412 eNodeB overall dimensions	2-12
EZBFo battery module overview	2-14
Equipment weights and dimensions	2-16
Physical interfaces	2-18

Background information

Overview

Purpose

The following section provides an overview of the 9412 eNodeB.

This material is provided to the installer so he can better understand the given installation procedures.

Contents

Functional description	2-4
--	-----

Functional description

Overview

This topic describes relevant product functional information.

Standard configuration

The standard 9412 Compact Outdoor comprises of the following two cabinets, which are physically identical, but provide different functionality:

- BB (Baseband) cabinet
- RF (Radio Frequency) cabinet

The BB and RF cabinet are connected with CPRI fiber optic cable and an alarm cable, both routing through the same 1-inch conduit. The alarm cable is required for DC cabinets only.

Distributed configuration

The distributed 9412 Compact Outdoor comprises of the following:

- BB (Baseband) cabinet
- RRH (Remote Radio Head)

The BB and RRH are connected with CPRI fiber optic cable.

For the Distributed System or RRH installation, refer to *Alcatel-Lucent 9442 Remote Radio Head (RRH) 1721 MHz (AWS) Installation Manual, 418-000-427*.

Product attributes

The following list the product attributes for the 9412 eNodeB.

- Flexible installation options: Floorstand/Pole/Wall mountable
- Without integrated power: (RF and BB cabinet)
 - Power: +24VDC BB Cabinet and +24VDC RF Cabinet
 - Power: -48VDC (BB Cabinet for Distributed System)
- With integrated power (AC): (BB with integrated power provides DC power to RF cabinet or RRHs).
 - AC BB Cabinet Supplies +24 VDC to RF Cabinet
 - AC BB Cabinet Supplies -48 VDC to RF Cabinet
- Power: -48VDC (BB distributed)
- Without integrated power: (RF and BB cabinet)
- With integrated power (AC): (BB with integrated power provides DC power to RF cabinet or RRHs).
- ?CPRI links between BB and RF cabinets or BB and RRHs

-
- The BB cabinet houses the d2U, a PDP (Power Distribution Panel), eAM (Enhanced Alarm Module), a Fan tray, and a 2U user space depending upon the configuration
 - The BB cabinet can support the SAR module
 - The RF cabinet houses a PDP, a Fan tray and 3 TRDUs
 - Accepts GigE fiber optic backhaul
 - The system may support up to 32 user alarms
 - Supports External Battery Backup (EZBFo)
 - Supports public safety configuration.

Physical description

Overview

Purpose

This section provides an overview of the equipment inside the 9412 eNodeB.

Contents

9412 cabinet overview (Standard DC cabinets)	2-7
9412 cabinet overview (-48V DC Distributed cabinet)	2-9
9412 cabinet overview (AC cabinet)	2-10
9412 eNodeB overall dimensions	2-12
EZBFo battery module overview	2-14
Equipment weights and dimensions	2-16
Physical interfaces	2-18

9412 cabinet overview (Standard DC cabinets)

Overview

This topic describes the various internal configurations for the cabinet.

9412 eNodeB- external view

The following diagram shows the external view for the 9412 eNodeB outdoor cabinet.

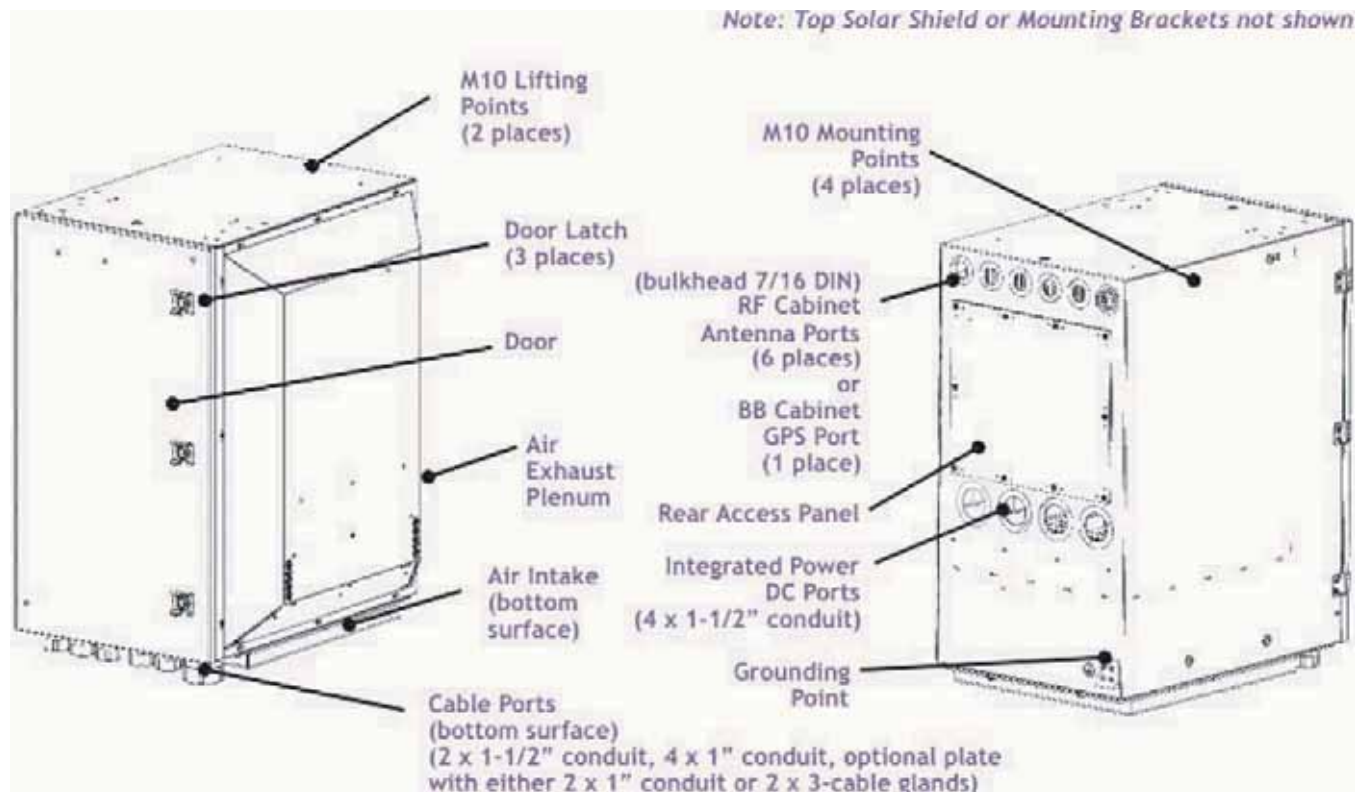

9412 eNodeB- internal view (+24 VDC version)

The following diagram shows the internal components in the 9412 eNodeB cabinet.

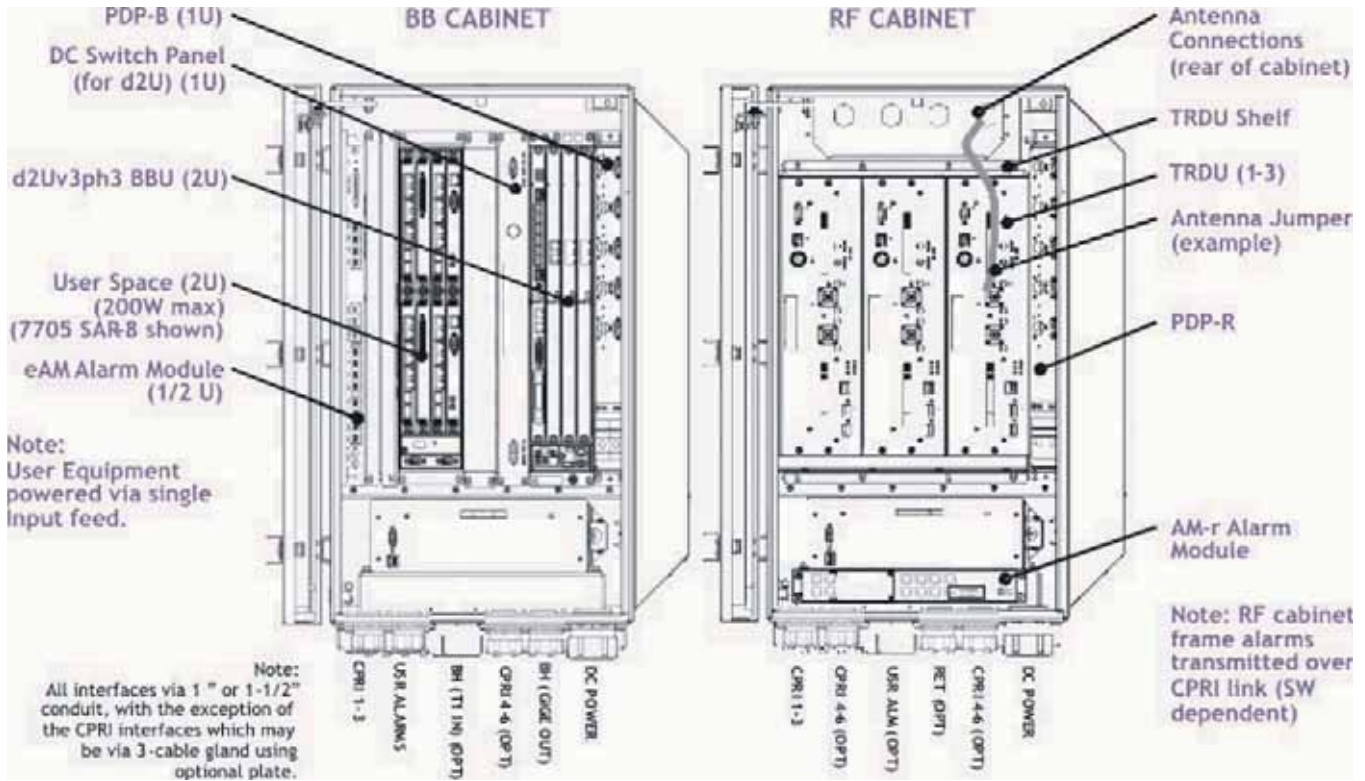

9412 cabinet overview (-48V DC Distributed cabinet)

BB cabinet -Internal-view (DC Distributed version)

The following diagram shows the internal components in the 9412 eNodeB Distributed cabinet (dual band).

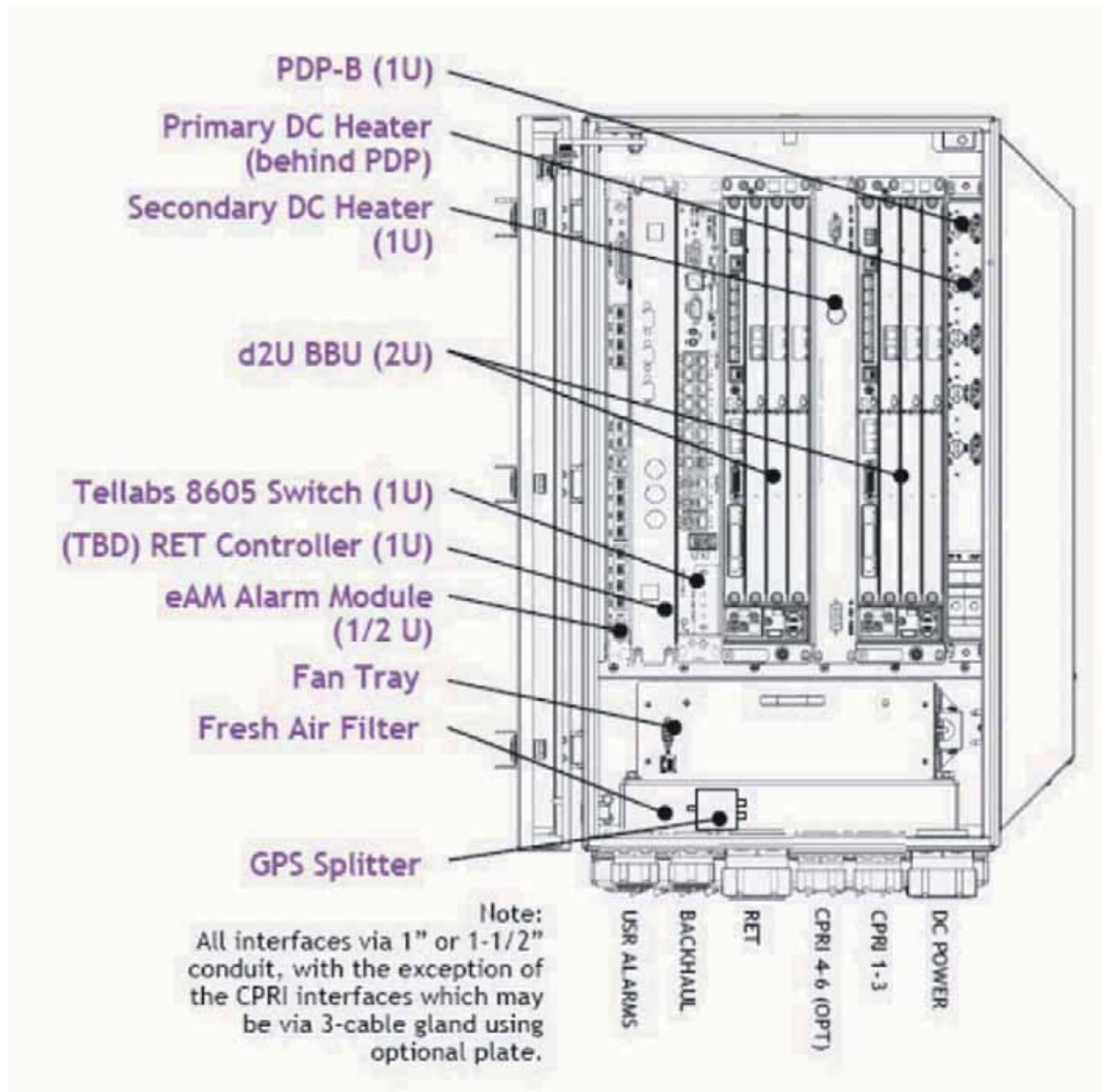

9412 cabinet overview (AC cabinet)

AC BB cabinet and +24 V DC RF Cabinet (DC power for RF cabinet supplied by BB cabinet)

The following diagram shows the internal components in the 9412 Compact cabinet for a +24V configuration.

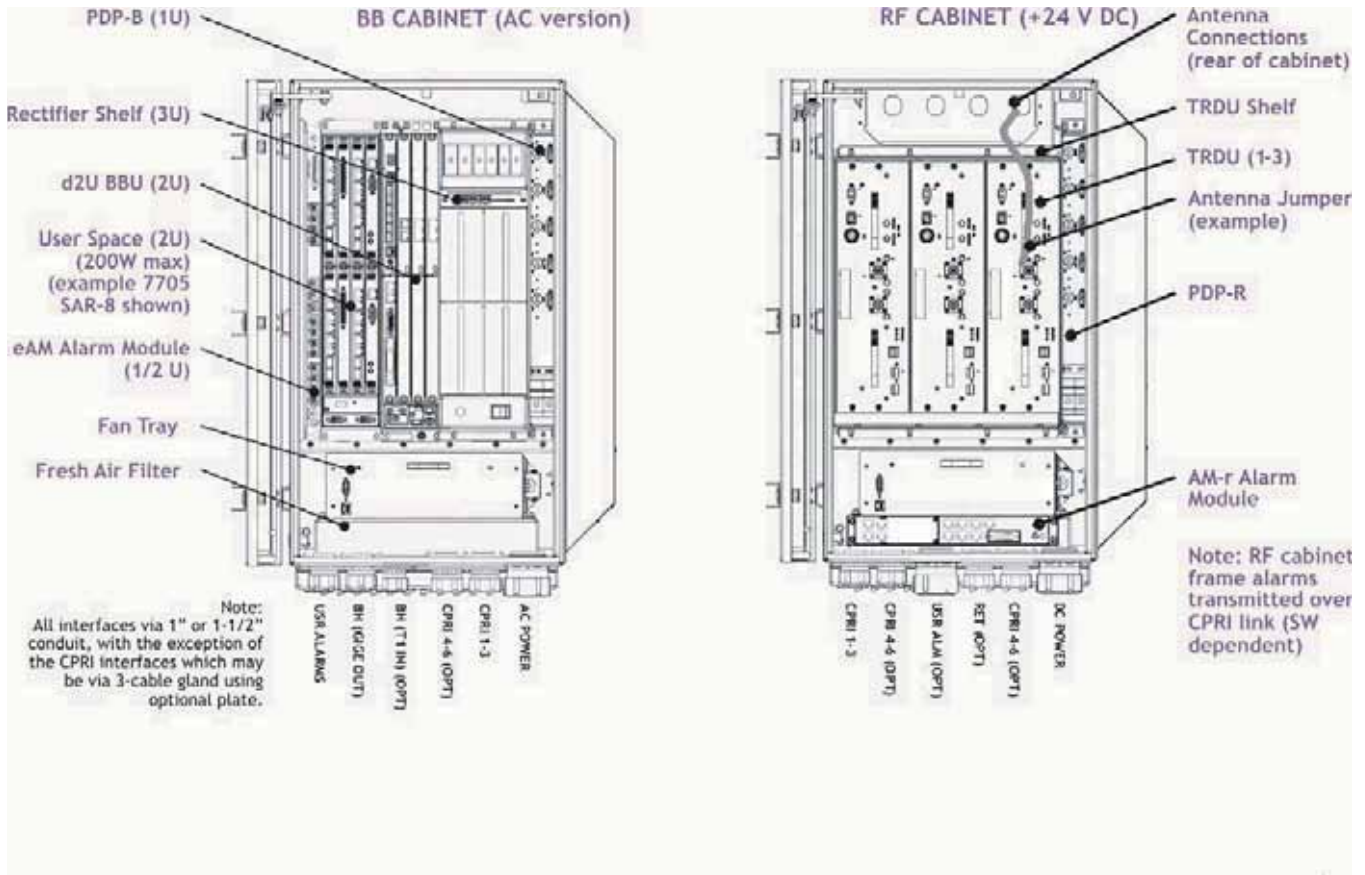

AC BB cabinet and -48 V DC RF Cabinet (DC power for RF cabinet supplied by BB cabinet)

The following diagram shows the internal components in the 9412 Compact cabinet for a -48V configuration.

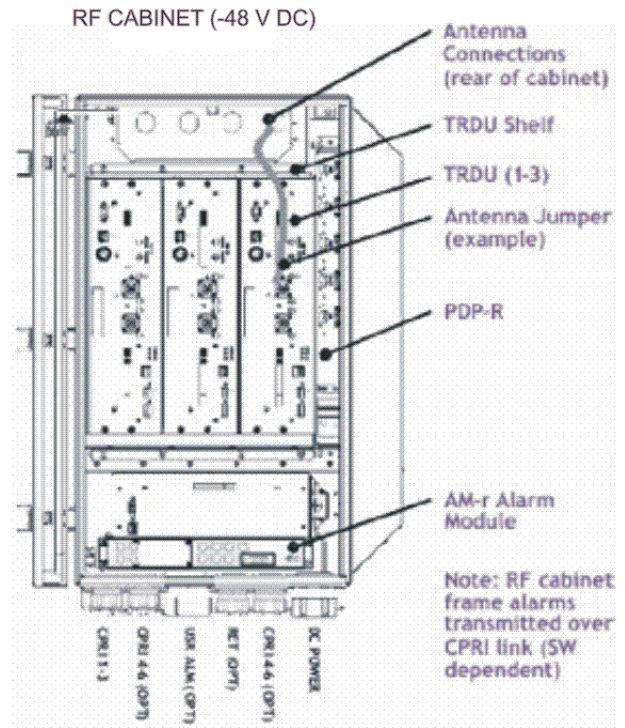
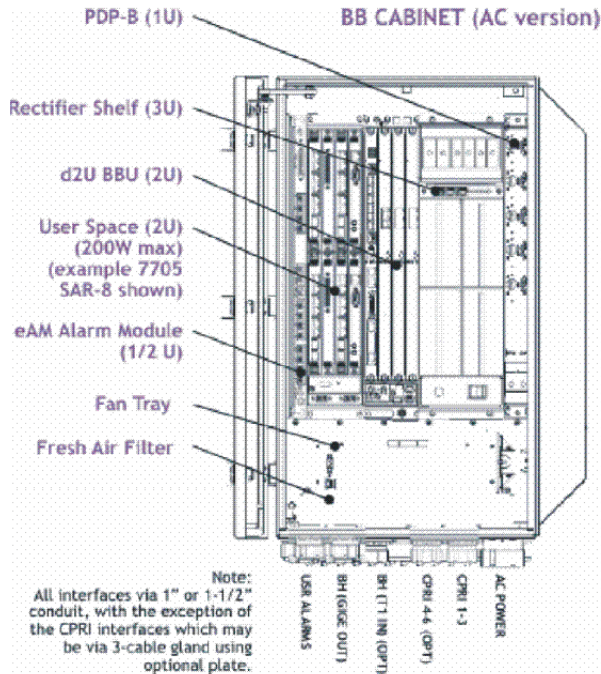

9412 eNodeB overall dimensions

9412 eNodeB -Overall Dimensions

Two following diagram shows the 9412 eNodeB outdoor cabinet with dimensions. For more details on weights and dimensions, refer to “[Equipment weights and dimensions](#)” (p. 2-16)

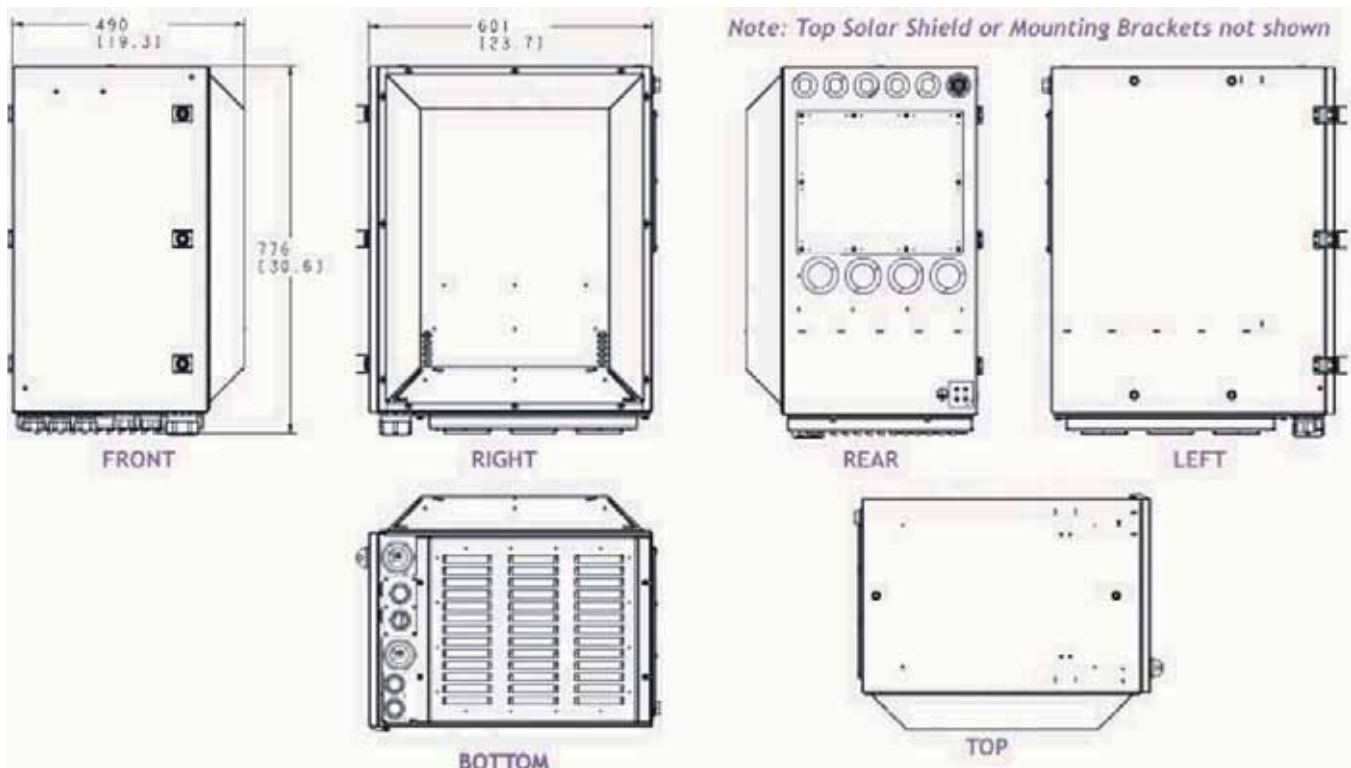

Dual floor-stand overall dimensions

The following diagram shows dimensions of the 9412 eNodeB cabinets configured on the dual floor-stand

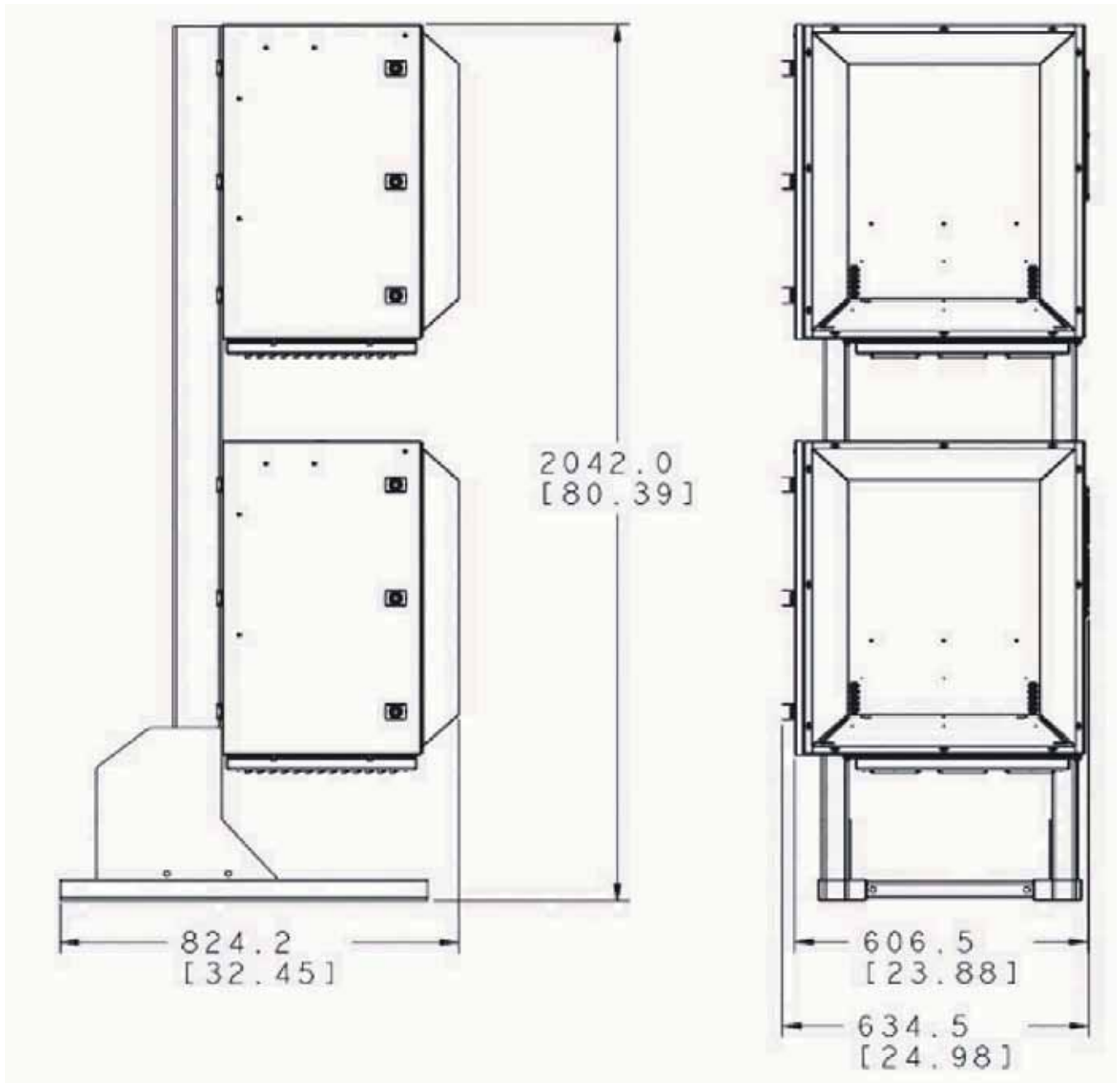

EZBFo dimensions

The following shows the dimensions of the EZBFo:

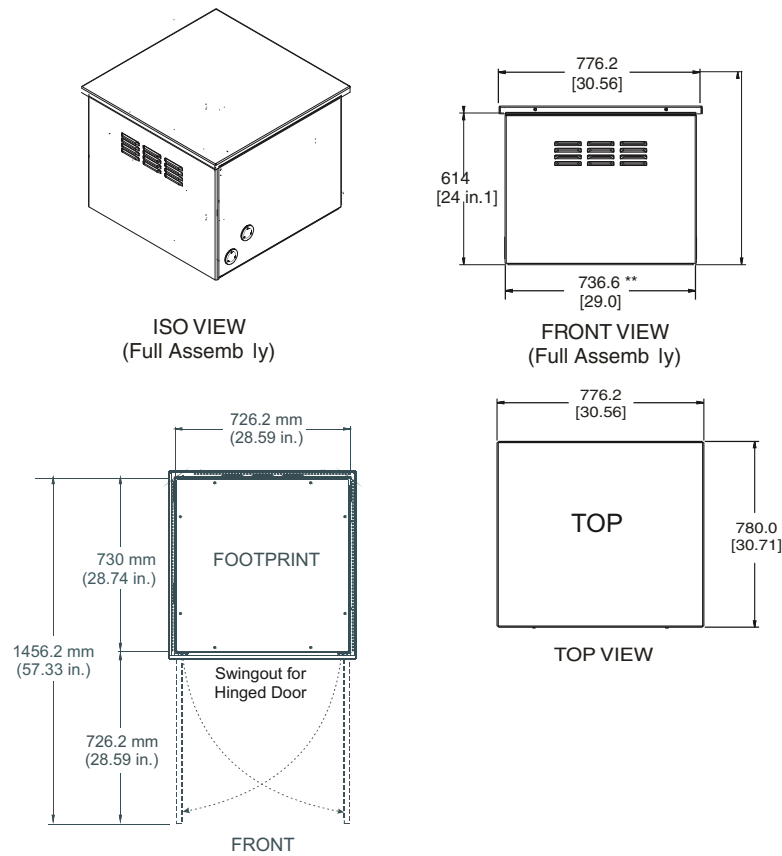

Physical interfaces

Overview

This topic covers the physical interfaces on the 9412 eNodeB outdoor cabinets, such as RF connections, GPS connections, grounding points, and cable termination points.

Cable interfaces

The following cable interface points are found on the eNodeB:

- DC power
- AC power
- Grounding
- RF antennas (to RF cabinet)
- GPS antenna (to BB cabinet)
- User Alarm
- Fiber

Antenna interface

The following figure shows the antenna interface on the top-rear of the eNodeB cabinets.

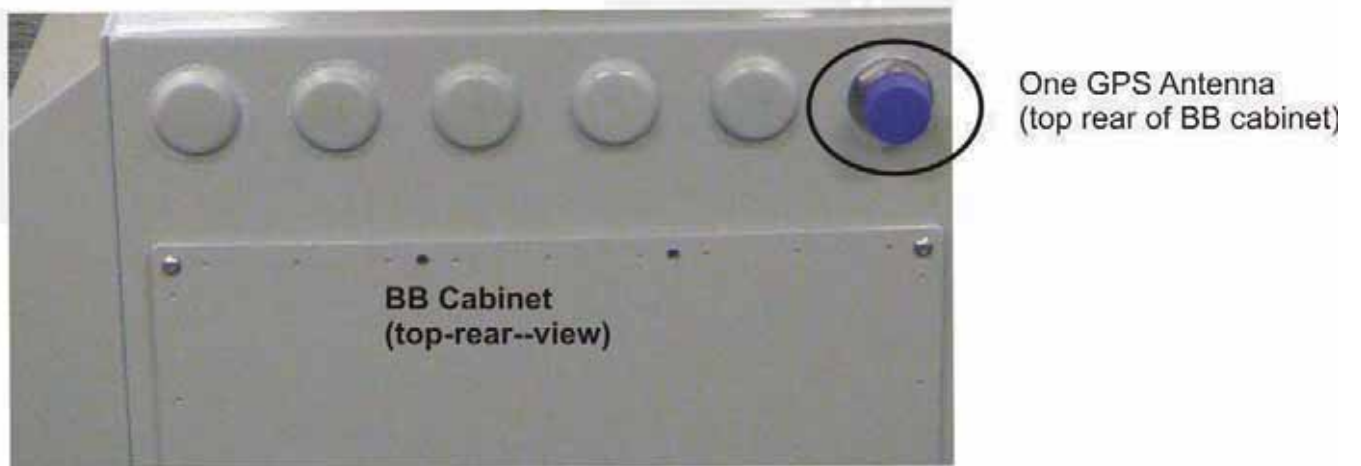
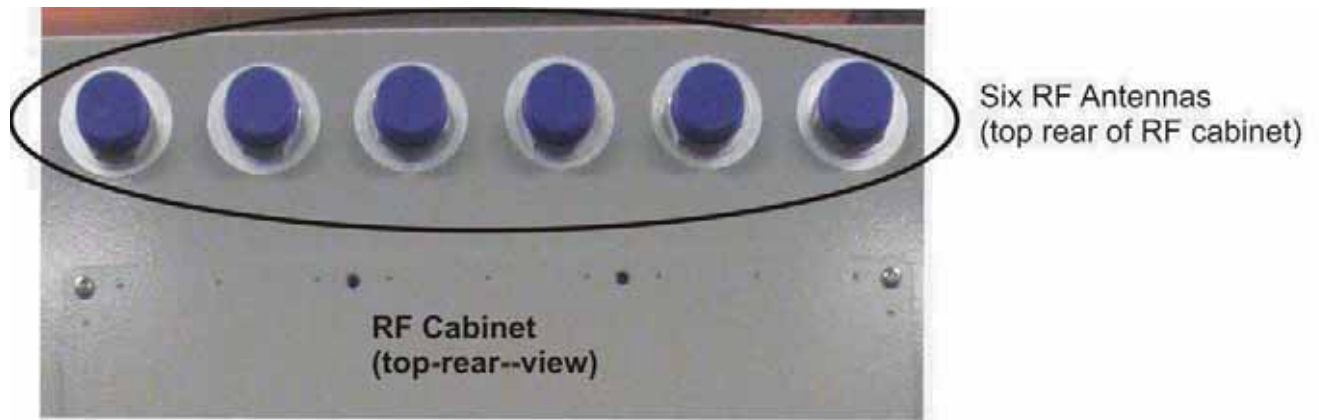

DC cable termination points

The following figure shows the DC cable terminal block inside the RF and BB cabinets.

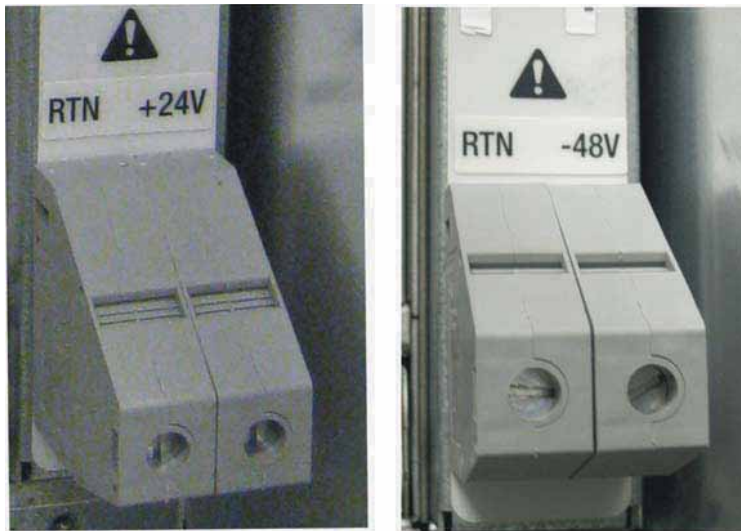

DC Terminal block
(lower- right--inside the RF and BB cabinets)

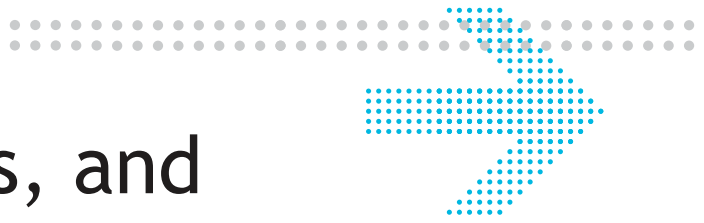

3 Tools, materials, and checklist

Overview

Purpose

This chapter provides general instructions for anchor installation and cabinet handling. Also included are the procedures for cabinet placement, anchoring, and grounding.

Contents

Preparatory information	3-2
Tools required for installation	3-3
Torque requirements	3-6
Physical installation process overview	3-8
Installation procedure checklist	3-9
Verify site preparation completed	3-10

Preparatory information

Overview

Purpose

This section presents information and procedures that are relevant before the 9412 eNodeB can be placed, anchored, and grounded.

Also included in this section is information for verifying that site preparation requirements have been met, so installation of the product can begin properly.

Reference documents

Further information on cabinet clearances and anchor holes can also be found in the *Alcatel-Lucent 9412 eNodeB Compact Outdoor Site Preparation Guidelines*, 418-000-414.

Refer to the site-specific layout information for details on where the equipment must be positioned.

This document also contains all necessary information on how to mark the positions of the anchor holes and how to drill them.

Contents

Tools required for installation	3-3
Torque requirements	3-6
Physical installation process overview	3-8
Installation procedure checklist	3-9
Verify site preparation completed	3-10

Tools required for installation

Overview

This section provides a master list of all tools, materials, and parts required to perform the installation.

Tools



CAUTION

Personnel injury or equipment damage

If the installation is performed with energized DC circuits, be sure to use tools that are properly insulated.

The following is a master list, in alphabetical order, of all tools that may be utilized during installation:

- Adjustable open-ended wrench (or set of fixed open-ended wrenches)
- Antioxidant compound
- B connecting links, or equivalent (quantity 3)
- Bolt anchor setting tool
- Bonding clamps for facility and phone line cables (normally provided by telephone company)
- Box cutter or equivalent for opening packages
- Chalk line
- Channel-lock pliers [for 2-1/2 inch nuts, 19 mm (3/4 inch) wide, maximum]
- Channel-lock pliers (standard)
- Crimping tools 22-16 gauge, 10-4/0 gauge (5-120 mm²) for installing terminal lugs and c-taps
- Derrick, capable of lifting the cabinet
- Drill and drill bits [including 16 mm (5/8 inch) and 18 mm (11/16 inch) for drilling anchor holes]
- Drill - Pneumatic Hammer (R-5006)
- Roto-Stop Hammer Kit (R-4416) with 1/2 inch (12 mm) chuck or equivalent to drill anchor holes
- Ear protection gear
- Electrical conduit installation equipment and materials
- Electrical tape

- ESD wrist strap
- Eye-bolts (M10/R-ITE-6111), for lifting cabinet
- Eye protection gear
- Fish tape
- Floor punch, for cutting asbestos floor tile prior to drilling
- Floor tile puller, for raised floor tiles
- Forklift, Hoist, Rol-A-Lift, or equivalent lift (non-tilt) capable of lifting and moving the cabinet into final position
- Galvanizing paint
- Gloves -- Low-voltage rubber lineman's gloves (R-4285)
- Hammer, 0.5 kg (16 oz) for anchor installation, etc.
- Heat gun for heat shrink tubing
- Insulated gloves
- Insulated hand tools (for completing electrical connections)
- Ladder or work stand/stool so installer can access top of the cabinet and ladder rack. Most connections are elevated. Two work platforms are required so two installers can work efficiently.
- Level 1.5 meters (4 feet), steel
- Lifting device (R-5312) and lifting boom
- Marker, for marking floor for lineup and drilling
- Measuring tape
- Nut driver set (decimal) with 10 inch extension
- Nut driver set (metric) with 250 mm extension
- Ohmmeter (multimeter, volt/ohmmeter, or equivalent)
- Pliers
- Plumb line
- Pry bar
- Safety goggles or glasses (R-3055)
- Screwdrivers (power and manual), flat-blade, Phillips
- Silicone caulk
- Socket sets (decimal and metric) various drives
- Socket with 6" extension (to bolt cabinet to the floorstand)
- For stripping tools for jumper cables go to table for "Jumper cable and connector stripping tools" "[Jumper cable and connector stripping tools](#)" (p. 7-10)
- Torque wrenches, 2 - 34 Nm (17.7 - 300 in-lb)
- Torque wrenches, 6 - 200 Nm (4.4 - 150 ft-lb)

Metric Screw Size	SAE Screw Size	Torque - in-lb [or ft-lb] and (Nm)					
		Wire Connections		Head Tightened		Nut Tightened	
		Slotted Machine	Hex or Socket Cap	Slotted Machine	Hex or Socket Cap	Slotted Machine	Hex or Socket Cap
M14	1/2-13	-	500 (56.5)	-	585 (66.1)	585 (66.1)	710 (80.2)
M16	5/8-11	-	[71] (96.3)	-	[97] (131.5)	[97] (131.5)	[118] (160.0)
M20	3/4-10	-	[125] (169.5)	-	[172] (233.2)	[172] (233.2)	[209] (283.4)

Torque requirements for DC terminal block

The table below gives the torque requirements for the DC terminal block.

Terminal block	Minimum torque (Nm)	Maximum torque (Nm)
DC terminal block	6 (53 in-lb)	8 (71 in-lb)

Physical installation process overview

Overview

This topic provides the steps for installing the cabinet.

Installation process

Following are the high level steps of the installation process:

1. Verify site preparation is complete
2. Place cabinet
3. Anchor cabinet
4. Ground cabinet
5. Connect GigE backhaul fiber cable
6. Connect User Alarm cables
7. Connect AC/DC power cables
8. Install secondary GPS surge protector at BB cabinet
9. Connect GPS cable
10. Connect RF cables
11. Initial start-up & system test.

Installation procedure checklist

Overview

The following is a procedure checklist.

Done	N/A	Task
		“Verify site preparation completed” (p. 3-10)
		“General installation procedure for twisted-pair cables” (p. 5-28)
		“Route and connect User Alarm cable” (p. 5-23)
		“Connect DC cables to 9412 eNodeB (+24 VDC and -48 VDC)” (p. 6-3)
		“GPS jumper cable” (p. 7-2)
		“RF jumper cables” (p. 7-9)
		“Final connections” (p. 7-14)

Verify site preparation completed

Overview

This topic describes what must be done to verify that the site preparation is complete so that installation procedures can begin.

At this point, the installer must make sure that any requirements that have not been met are met here.

Verify site preparation

Before installation of the 9412 eNodeB can begin, the site preparation must be complete, in accordance with *Alcatel-Lucent 9412 eNodeB Compact outdoor Site Preparation Guidelines*, 418-000-414.

The following general requirements must be met before the installation of the 9412 eNodeB Compact cabinet can begin:

- Adequate clearance must be provided for service access.
- GigE (fiber optic) backhaul must be installed, and capable of accepting fiber optic Multi-Mode cable with LC connector.
- Grounding electrode system must be installed.
- RF and GPS antenna runs must be installed.
- Surge protection for RF antenna must be installed.
- Primary surge protector for GPS must be installed.
- Tower light power must be installed (if required).
- Tower light alarm must be installed (if required).
- Anchor holes must be drilled for floor stand mounting option.
- The environment must comply with limits listed in the site prep.
- Cable support structure must be installed.
- Conduits for routing cables to cabinet must be prepared.



4 Transport, mount, and ground cabinet

Overview

Purpose

This chapter provides general instructions for cabinet handling, cabinet placement, anchor installation, anchoring, and grounding of the radio cabinet.

Contents

Lifting and moving cabinets	4-2
Double stack floor stand lifting brackets	4-7
Install 9412 eNodeB Compact on the floor stand	4-9
Install 9412 eNodeB Compact on the pole	4-19
Pole mounting with pole band	4-21
Install 9412 eNodeB Compact on the wall	4-25
Ground the 9412 eNodeB Compact cabinets and floor stand	4-31

Lifting and moving cabinets

Purpose

Cabinets are usually shipped to the customer via truck and are delivered to the installation site. During installation, it may be necessary to lift the modular cell cabinet to move it to a new location. This section describes how to safely lift a modular cell cabinet. Use this information as you perform the procedures in this chapter.

Lifting machinery

To lift the cabinet, do one of the following:

- Use a forklift with forks that are at least 4 feet long to lift a cabinet that is attached to a pallet, from the bottom.
- Install lifting eyebolts on the top of the cabinet, and use a derrick and slings to lift the cabinet from its top.
- Use the recommended lifting device described on [“Recommended lifting device”](#) (p. 4-6)

Safety precautions for using lifting machinery



WARNING

Personnel injury or equipment damage

Cabinets are too heavy to move without appropriate lifting devices.

Derrick equipment or a forklift must be used to lift the cabinet. Do not attempt to move the cabinet manually, or remove it from the pallet manually.



WARNING

Personnel injury or equipment damage

Lifting double stack floor stand with BB and RF mounted on it.

Do NOT use the lifting points on the top of the cabinet, if lifting the double stack floor stand with both BB and RF mounted on it. This could cause personal injury or damage to the equipment. Lifting bracket must be used if lifting the double stack floor stand, refer to [“Double stack floor stand lifting brackets”](#) (p. 4-7)

Comply with the following guidelines when using lifting machinery:

- Only operators who are specifically trained and meet company requirements should be permitted to operate derrick or forklift equipment.
- All persons working with derricks or forklifts must wear standard safety headgear, footwear, eye protection, and insulated gloves (if required).
- Do not operate a derrick until both stabilizers are extended and firmly supported. Do not extend stabilizers after a load is suspended from the derrick.
- While raising the derrick from the stowed position, be alert for overhead obstructions, such as power lines, that may interfere.
- At all times, keep bystanders away from the work area.
- Operators must not suspend loads over people, nor can any person be permitted to work, stand, or pass under a suspended load.
- When a cabinet is being lifted with slings, it is unsafe to lift the cabinet when lifting sling angle is less than 45 degrees to the top of the cabinet.

Guidelines for using a derrick

When a derrick is used to move a cabinet, lifting eyebolts and slings are used to attach the cabinet to the derrick.

Lifting eyebolts

Four R-ITE-6111 M10 lifting eyebolts are screwed into the eyebolt holes on the top of the cabinet, as shown in the following figure.

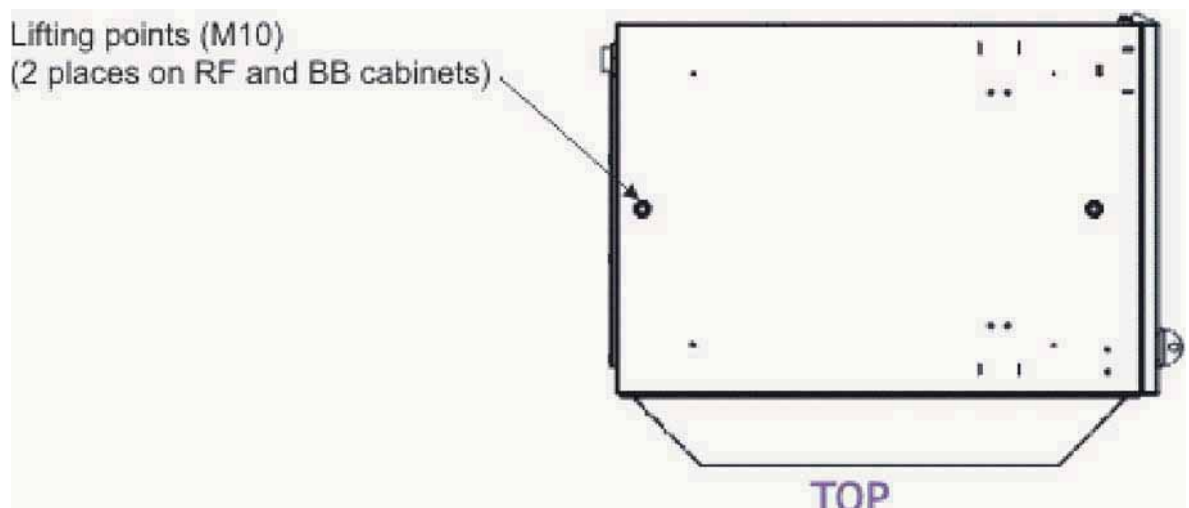

Position each lifting eyebolt so that the plane of the eyebolt points at the center of the top of the cabinet, as shown in the previous figure. When this is done, and the load is applied, the plane of the eyebolt will align with the load. Eyebolts that are not aligned with the load can bend as the load pulls on them sideways.

Observe the following guidelines about lifting eyebolts:

- The eyebolts screw into factory-installed nuts on top of the cabinet. These nuts must be held in position while the lifting eyebolt is screwed in.
- Do not overtighten the lifting eyebolt.
- The shoulder of the lifting eyebolt must be properly seated (should bear firmly against the mating part). If it is not, the working loads must be reduced substantially. A steel washer or spacer may be required for proper seating.

Important! If the plane of the eyebolts does not point to the center of the cabinet after tightening, the eyebolts may be loosen less than one turn.

- Tightness and seating must be checked after initial load.
- Lifting eyebolts should never be painted or otherwise coated, because such coatings will cover up flaws.

Slings

Attach the slings to the boom line with a B-connecting link or clevis. Attach the other ends of the slings to the lifting eyebolts with a B connecting link or clevis.

When a cabinet is being lifted with slings, it is unsafe to lift the cabinet when the lifting sling angle is less than 45 degrees to the top of the cabinet. At closer than 45 degrees, there is too much side stress on the lifting eyebolts. Use slings that are long enough to keep the lifting sling angle at greater than 45 degrees from the top of the cabinet.

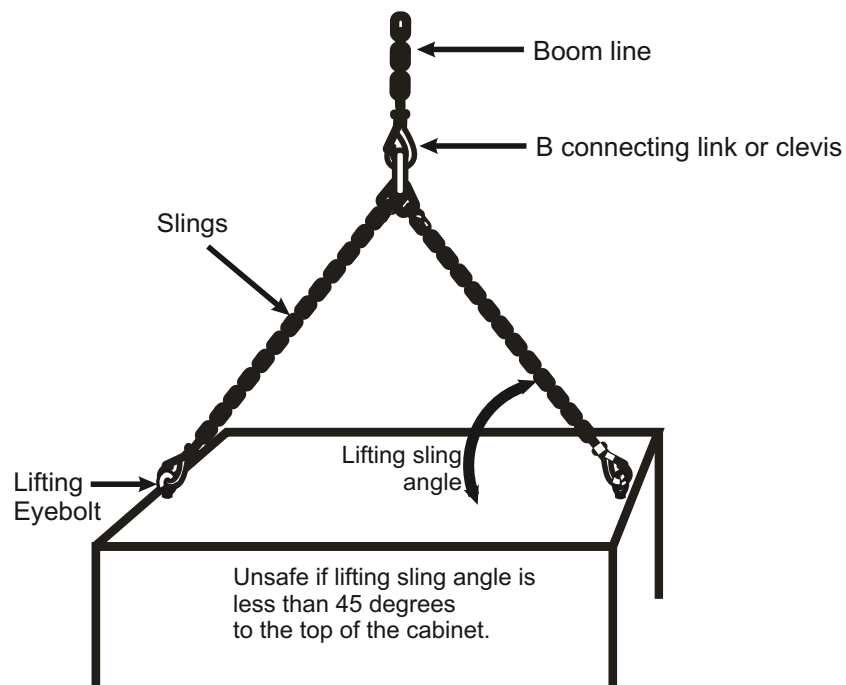

Control the cabinet while it is being lifted**NOTICE****When Moving Cabinet**

When moving a cabinet in the following procedures, do not tilt the cabinet beyond 30 degrees from vertical. Do not stand under the cabinet.

A rope tied to the pallet attached to the cabinet should be used to guide the cabinet while it is being lifted. The rope must be sufficiently long. As the cabinet is being lifted and transported, use the rope to guide the cabinet and prevent the cabinet from tilting or swinging.

Always lift cabinets carefully, and keep the boom line tight to prevent the cabinet from tipping while it is moving. At the end of the lift, slowly place the cabinet on the ground.

Recommended lifting device

The following lifting truck is recommended for the 9412. The lifting device is available from Alcatel-Lucent (Part# R-5312).

Lifting device

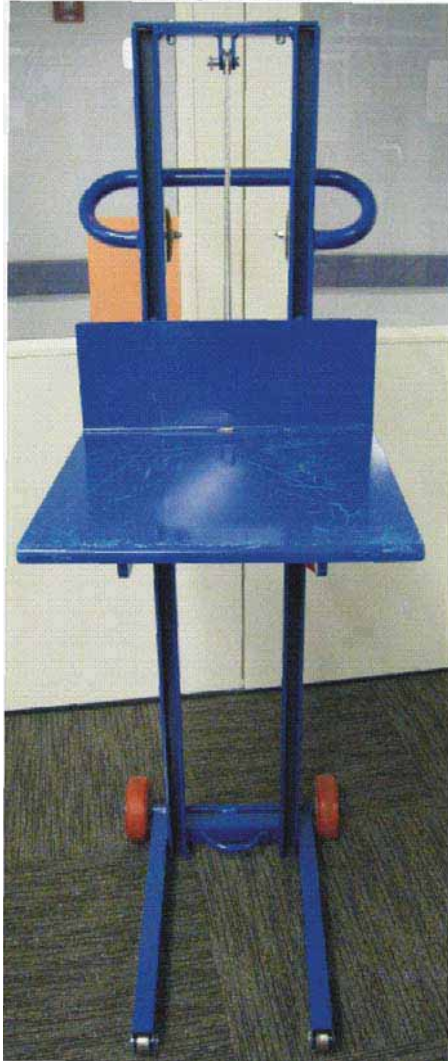

Double stack floor stand lifting brackets

Double stack floor stand lifting overview

Note: The double stack floor stand with both BB and RF cabinets mounted to it, can be lifted using lifting brackets.

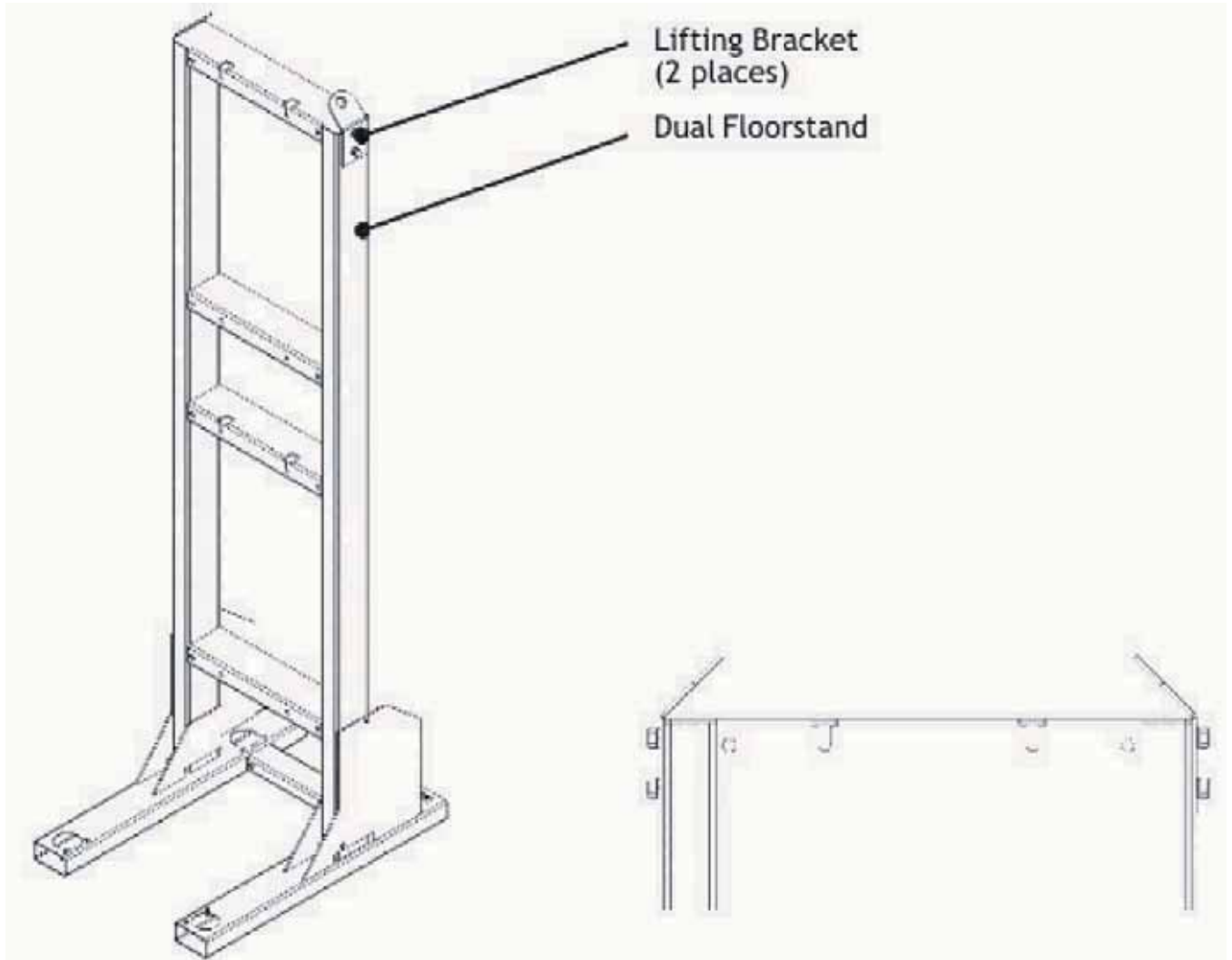

Install lifting brackets on the floor stand



WARNING

Personnel injury or equipment damage

Lifting double stack floor stand with BB and RF mounted on it.

Do NOT use the lifting points on the top of the cabinet if lifting the double stack floor stand with both BB and RF mounted on it. This could cause personal injury or damage to the equipment.

The lifting brackets are installed to the floor stand as shown in the following figure.

Note: The lifting sling angle at the lifting brackets should be 45°.

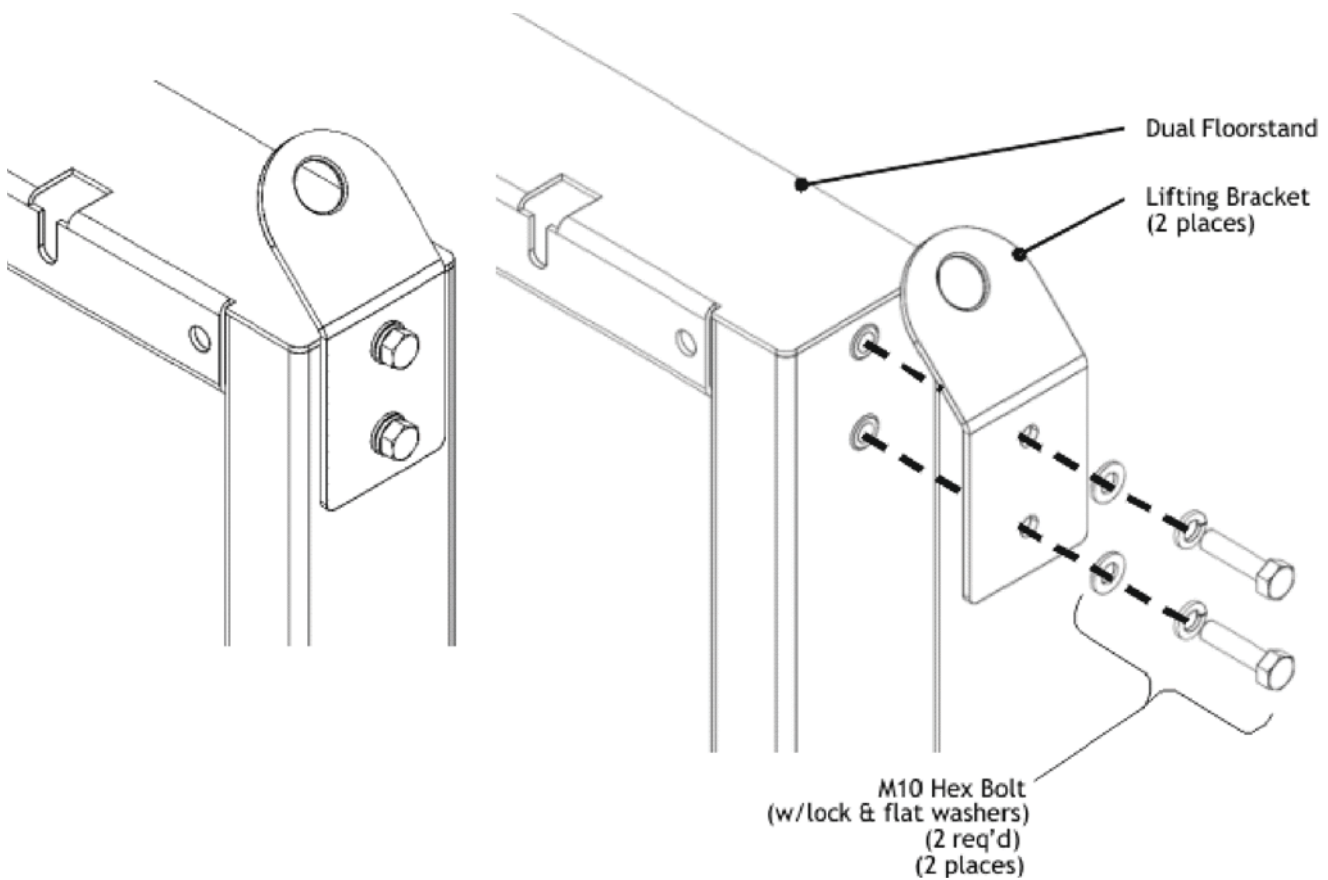

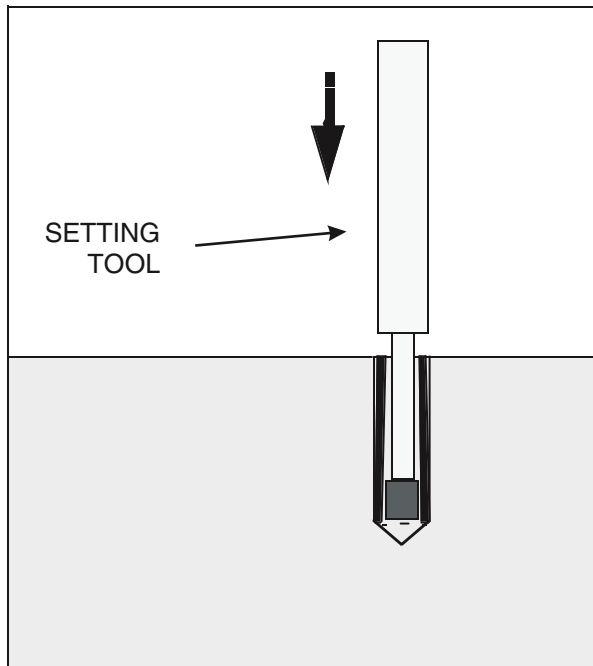

6 Hold a level against the floor stand vertical upright support.

7 Insert combinations of 1.5 mm shims and 3 mm shims under corners of the floor stand until both vertical uprights are true vertical as measured by the level.

Leveling is achieved by the use of shims. Each shim has a slot that is designed to fit around the body of the anchor. Keep the slot properly aligned when performing this step so that the anchor sleeves can later be set.

8 On the anchoring assembly, make sure the large plate washer, flat washer, and nut are assembled, as shown in the following figure.

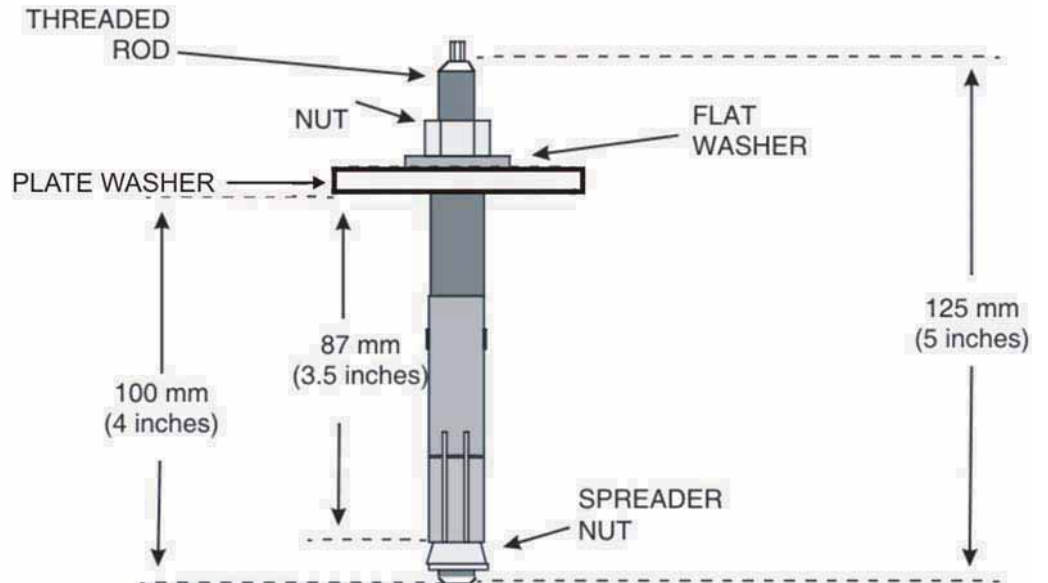

- 9 Torque anchor bolts as specified in “Anchoring specifications” (p. 4-9).
- 10 If ordered, install optional security cover plates on the feet of the floor stand, using security screws.

END OF STEPS

To mount the floor stand with anchor bolts to a metal structure

Note: The following materials are required to install the cabinet on a metal support structure.

Quantity	Item
4	M12 (1/2") bolt, 60mm (2") O. D. washer, M12 (1/2") lock washer, and 1 nut.

To install the bolts to a metal support structure , perform the following steps.

- 1 Verify that the floor stand has been aligned and centered over the holes in the metal support structure.

-
-
- 2 At four places in the bottom sides of the floor stand, install a hex bolt through a flat washer and then through the hole.

Make sure the 60 mm (2 inches) O.D. flat washer is underneath the head of the bolt. Otherwise, the bolt will not secure the floor stand.

-
- 3 Secure each bolt with a lock washer and nut.

-
- 4 Torque each bolt with a ratchet and deep socket to 25 ft-lb (32.2 Nm). Use a second wrench to hold the nut.

END OF STEPS

Install cabinet(s) on floor stand

Note: For double stack floor stand installation, remove the covers from the back of the floor stand, and install the BB cabinet first.

Perform the following procedure to install the cabinet(s) on the floor stand.

- 1 Loosely attach two side M10 hex bolts, flat washers, and lock washers to the top mounting holes on the back of the cabinet.

Do not tighten yet, install only halfway.

- 2 If you have not already done so, attach lifting harness to the two lifting points (eye bolts) of the cabinet as covered in [“Lifting and moving cabinets”](#) (p. 4-2).
-

- 3  **CAUTION**
Pinch Hazard

The bolts on the cabinet can pinch and damage your fingers. Keep fingers clear when lowering cabinet into position.

Carefully raise the cabinet into position using the hoisting mechanism, if required.

- 4 Carefully raise the cabinet so that it can be slid back onto the floor stand. Align top.
-

- 5 Hang the cabinet on the top slot of the floor stand using previously installed bolts.
-

- 6 Attach top of the floor stand to top of the cabinet using (2) M10 hardware (bolt, flat washer, and lock washer).
-

- 7 Install two M10 bolts with washers at the lower mounting holes of the cabinet.
-

- 8 Use torque wrench to tighten all the bolts to 32.2 Nm (25 ft-lbs).
-

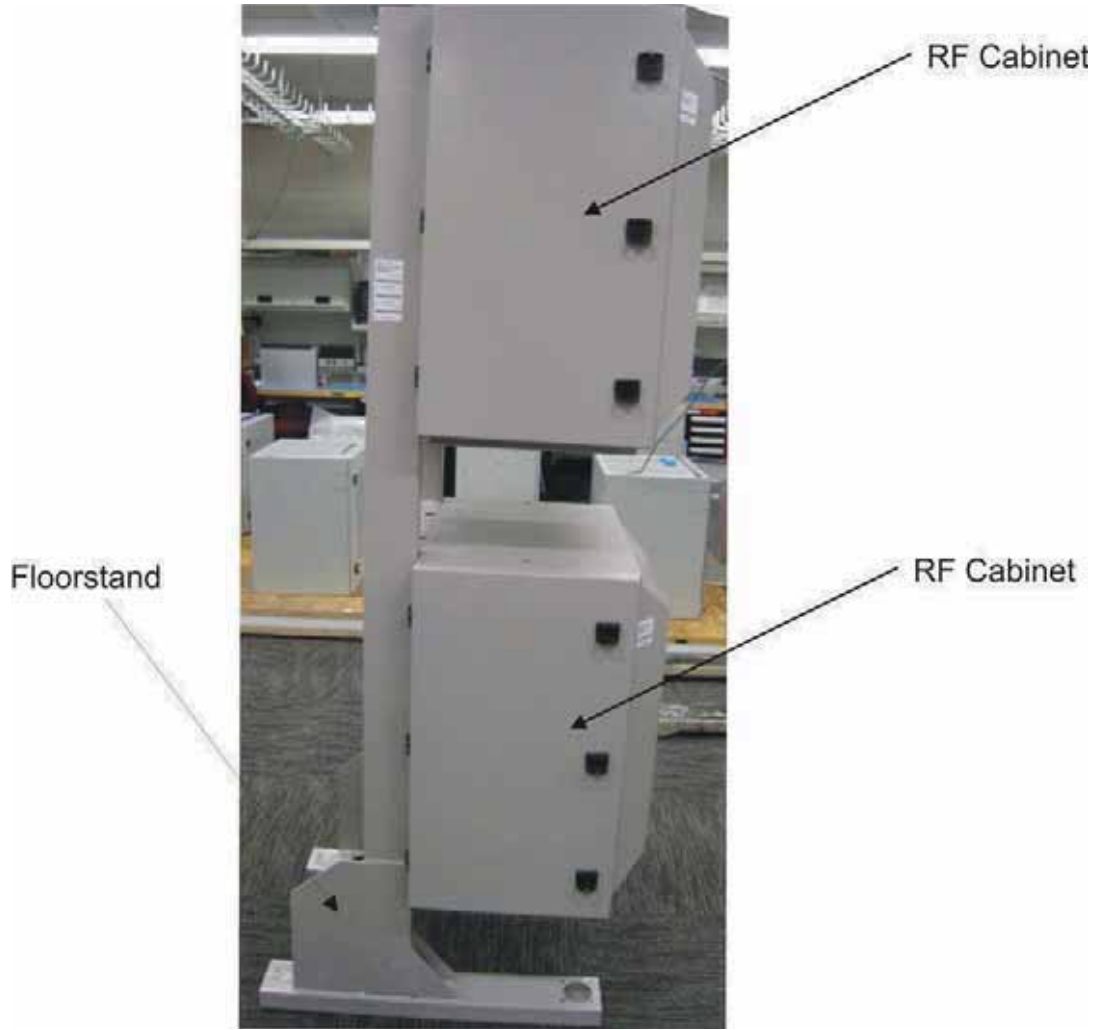

END OF STEPS

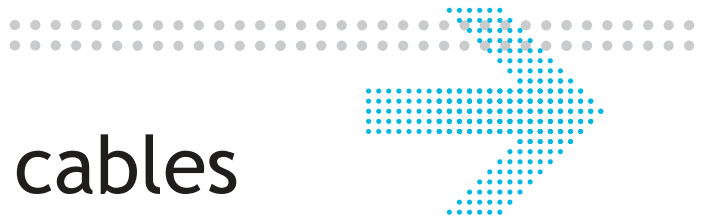

6 Connect power cables

Overview

Purpose

The following chapter shows how to connect power cables to the 9412 eNodeB.

Contents

Connect DC and AC power	6-2
Connect DC cables to 9412 eNodeB (+24 VDC and -48 VDC)	6-3
Connect DC power between RF and BB cabinet (AC configuration)	6-8
Connect DC power between RRH and BB cabinet (Distributed configuration)	6-11
Route and connect the AC cable	6-13

Connect DC and AC power

Overview

Purpose

The following section covers the procedures for connecting DC power to the 9412 eNodeB.

Contents

Connect DC cables to 9412 eNodeB (+24 VDC and -48 VDC)	6-3
Connect DC power between RF and BB cabinet (AC configuration)	6-8
Connect DC power between RRH and BB cabinet (Distributed configuration)	6-11
Route and connect the AC cable	6-13

Connect DC cables to 9412 eNodeB (+24 VDC and -48 VDC)

Overview

The following topic provides the procedure for connecting DC cables to the RF and BB cabinet.

The RF and BB cabinet accepts one DC feeder cable. The DC feeder cable is (1AWG), stranded copper wire.

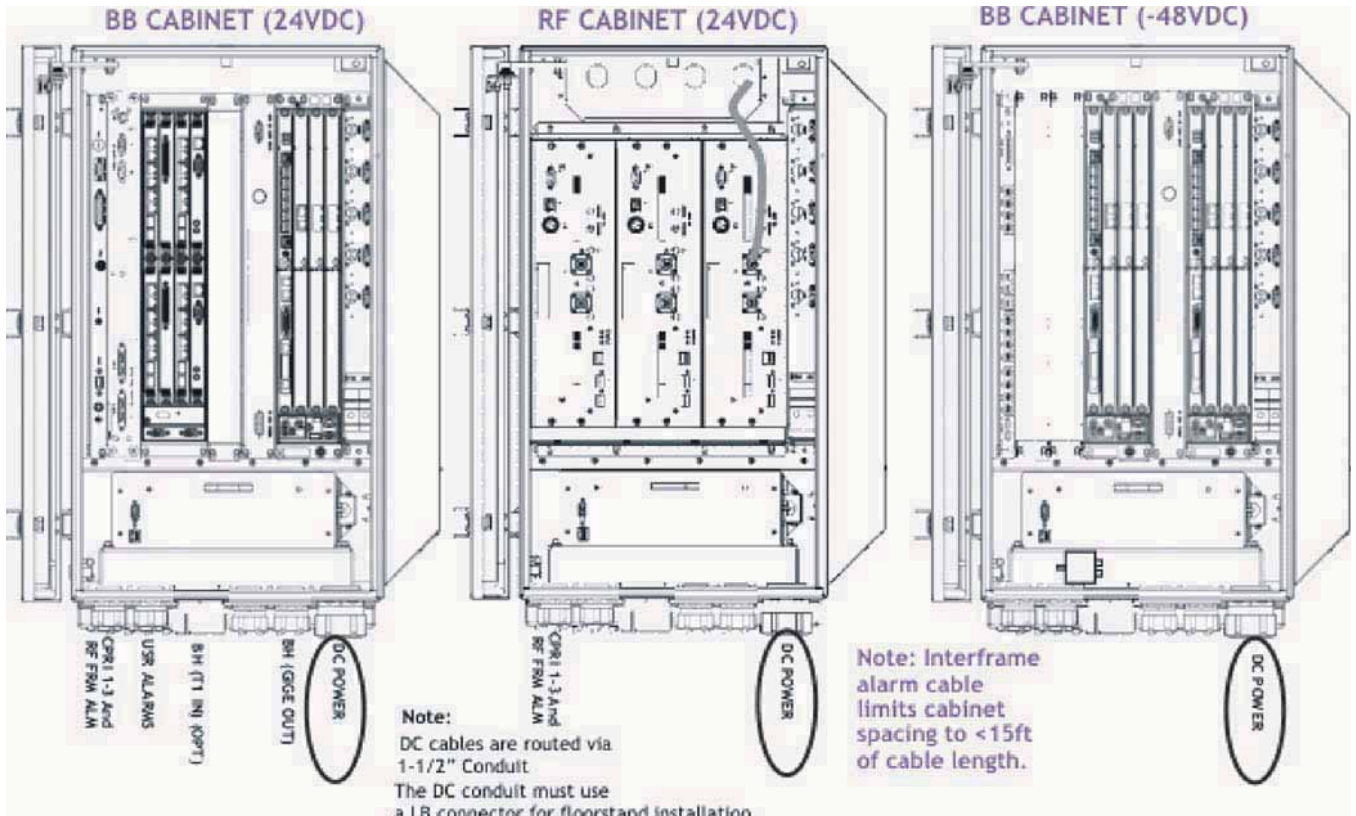

+24 VDC cable connections

The following table provides information about the +24 VDC feeder cable connections on each BB and RF cabinets.

Purpose	Wire size	Label on terminal block and wire color	
Feeder 1	1 AWG	<i>FEED 1</i>	+24 V
			RTN

-48 VDC cable connections

The following table provides information about the -48 VDC feeder cable connections on the BB and RF cabinets.

Purpose	Wire size	Label on terminal block and wire color	
Feeder 1	1 AWG	<i>FEED 1</i>	-48 V
			RTN

DC terminal block

The following figure shows the DC terminal block at the front, lower-right of the eNodeB cabinets.

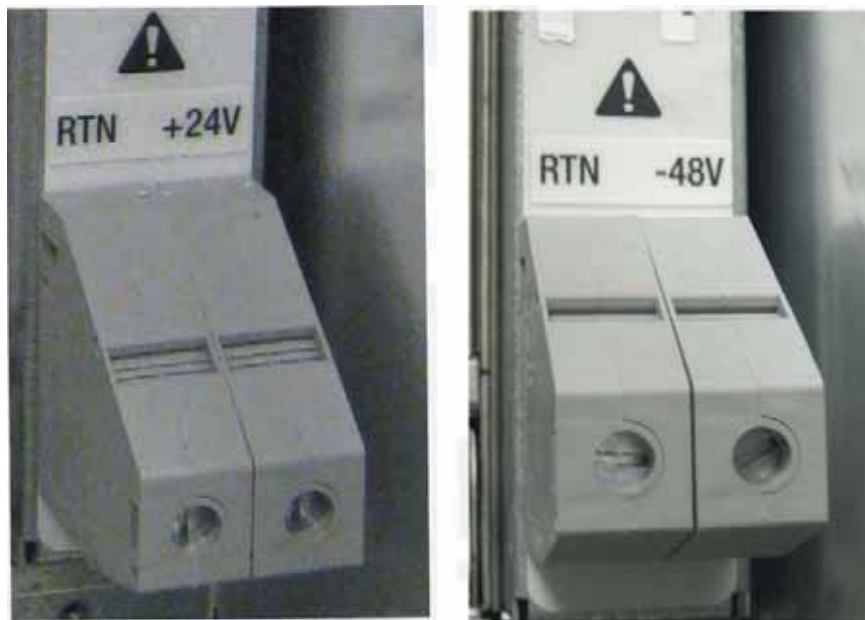

DC Terminal block
(lower- right--inside the RF and BB cabinets)

Before you begin

Make sure power at DC source is turned off.

Route and connect DC power cables for the RF and BB cabinet

Perform the following procedure to connect the DC power cables to the eNodeB:

- 1 Route the DC power cables via 1-1/2" conduit through the eNodeB to the DC terminal block located on the lower-right inside the RF and BB cabinet.

Note: The DC conduit must use an LB connector at the DC entry port as shown.

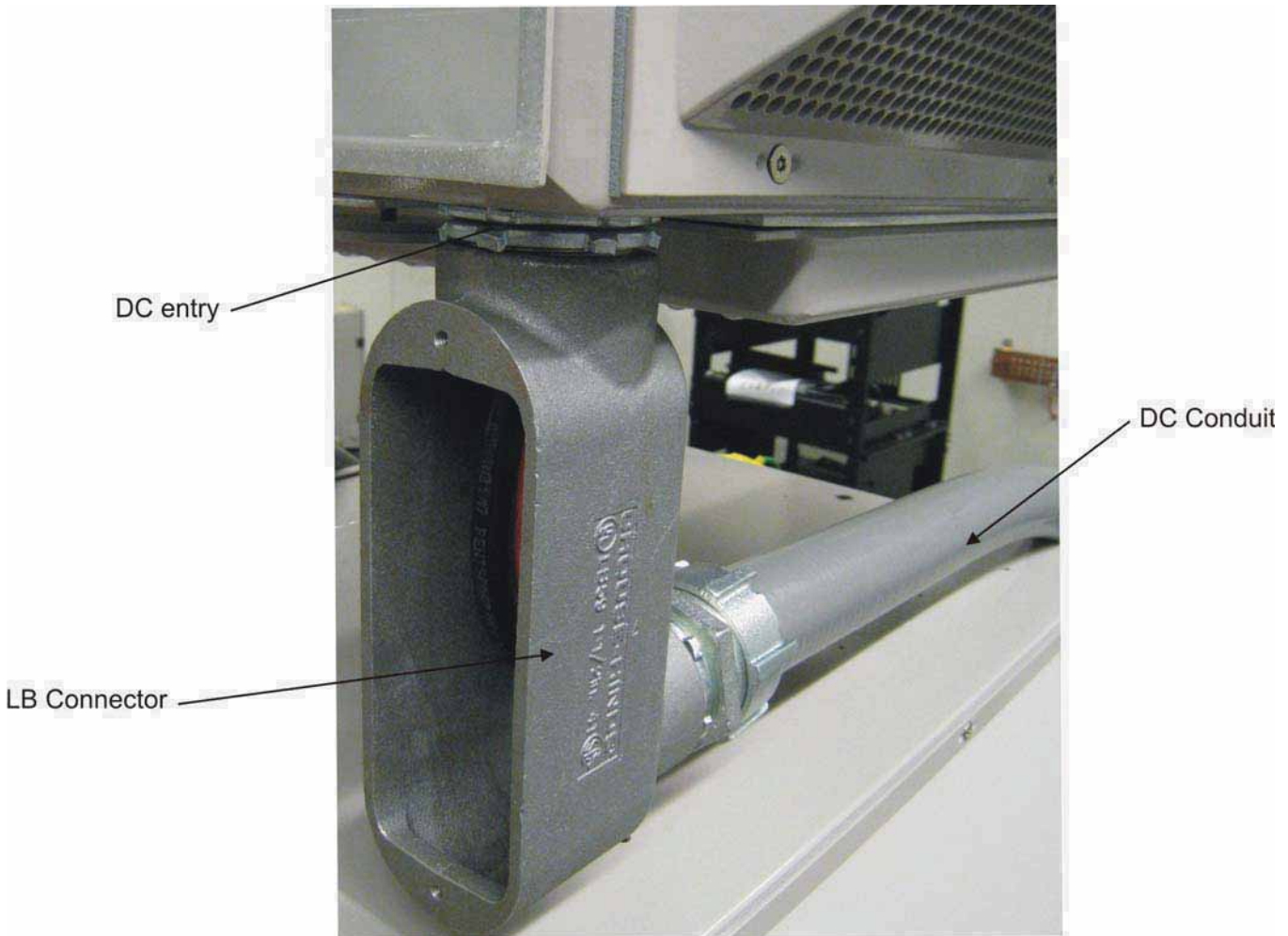

- 2 Cut each DC power cable to appropriate length so it reaches the terminals on the DC terminal block. Strip 20 mm (0.8 in) of insulation from the end of each DC power cable.

The terminals on the DC terminal block are labeled as follows:

- FEED 1 (+24 V and RTN)
- FEED 1 (-48 V and RTN)

Important! Check polarity of cables before connecting to terminal blocks.

- 3 Insert the end of each DC power cable into its corresponding terminal and torque each terminal to 6 to 8 Nm (57 to 71 in-lb), using a 3/16-inch wide, flat blade screwdriver.

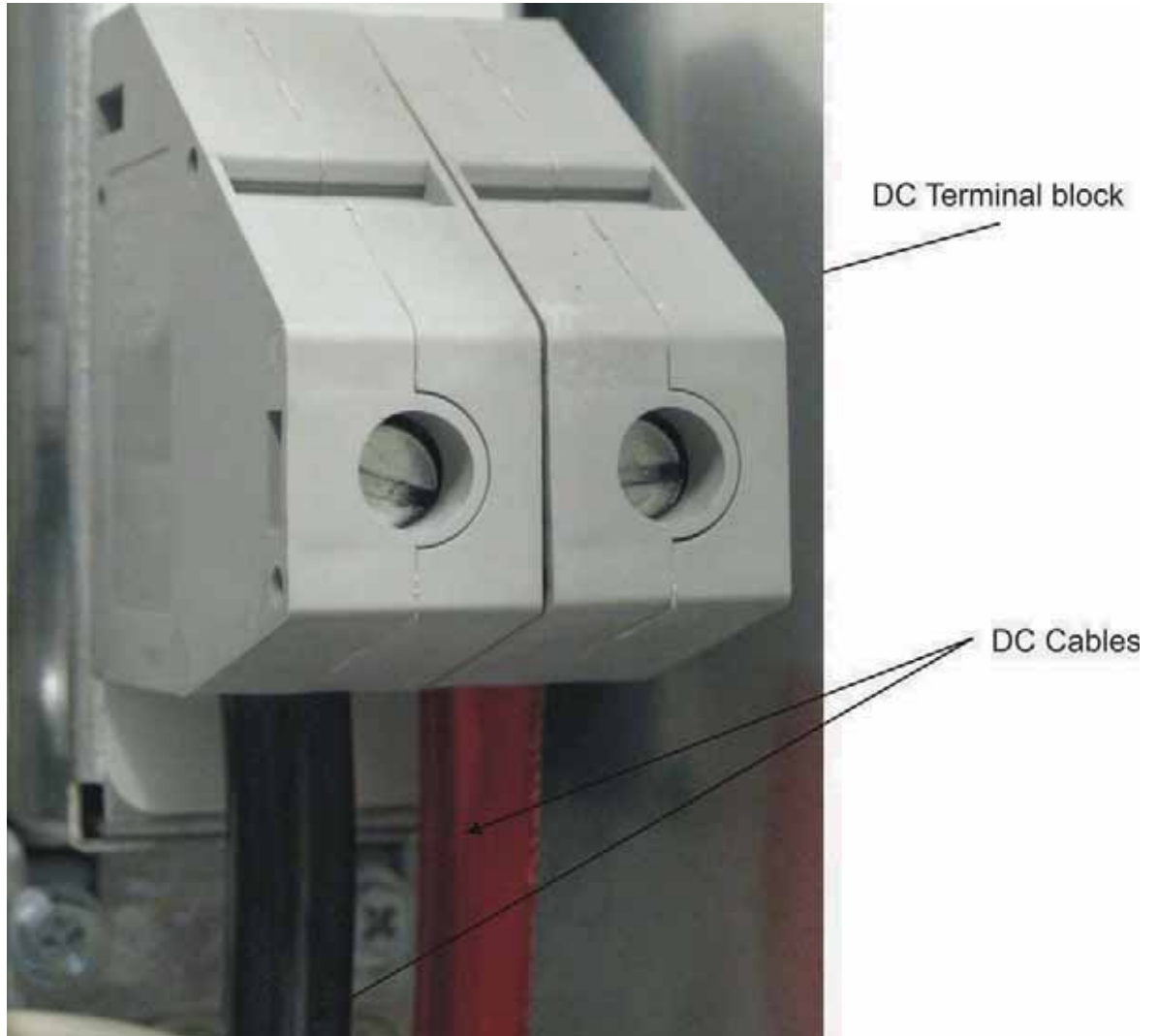

END OF STEPS

Connect DC power between RF and BB cabinet (AC configuration)

Route and connect DC cables between RF and BB cabinet

Note: If connecting DC power between the RRH and BB cabinet refer to “[Connect DC power between RRH and BB cabinet \(Distributed configuration\)](#)” (p. 6-11)

Perform the following procedures to connect DC power between the RF and BB cabinet.

-
- 1 Connect LB and conduit connectors to the DC entry port on the rear of the RF and BB cabinet.

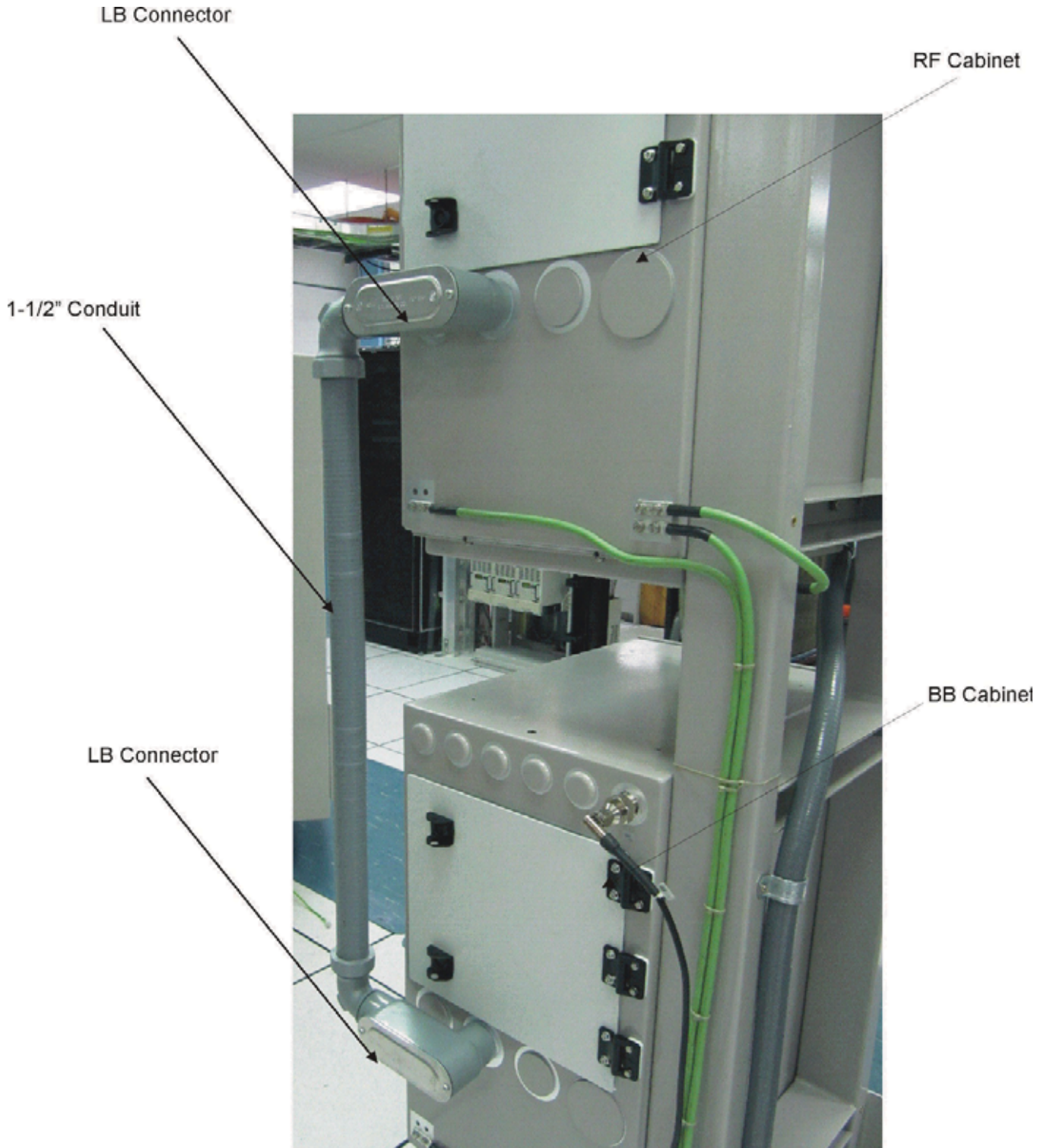

- 2 Cut the required flexible conduit to sufficient length to fit between the cabinets.

-
- 3 Connect the flexible conduit to the two installed LB connectors.

 - 4 Remove plastic cover from the DC distribution panel on the rear of the BB cabinet.

 - 5 Connect the DC cable lugs to Feed 1 (Red) and RTN (Black).

 - 6 Connect the loose end of the DC cable to the DC terminal block inside the RF cabinet.

END OF STEPS

Connect DC power between RRH and BB cabinet (Distributed configuration)

Route and connect DC cables between RRH and BB cabinet

Perform the following procedures to connect DC power between the RRH and BB cabinet.

- 1 Install 1 1/2" to 1" conduit Reducer at the DC entry port on the rear of the BB cabinet.

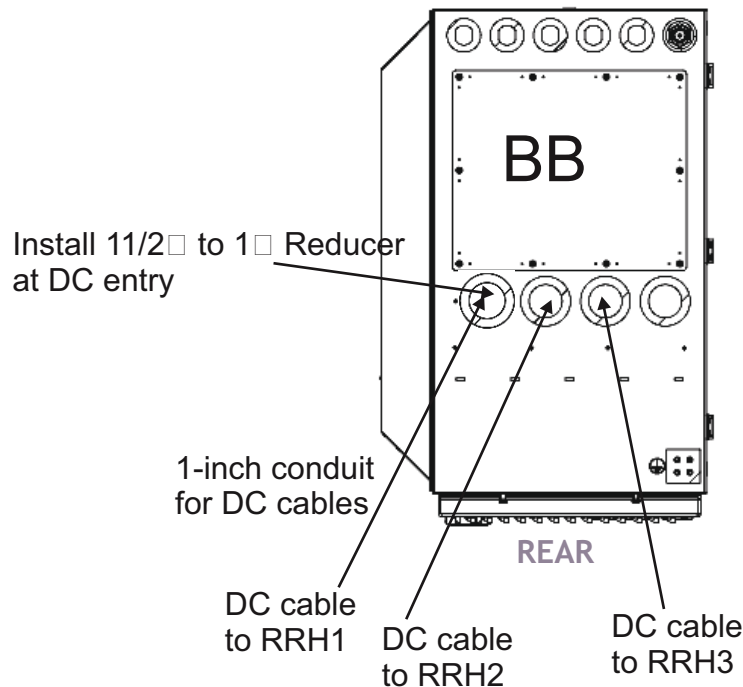

- 2 Cut the required 1-inch flexible conduit to sufficient length to fit between the BB and RRH(s).
- 3 Connect the flexible conduit to the installed Reducer.
- 4 Remove plastic cover from the DC distribution panel on the rear of the BB cabinet.
- 5 Connect the DC cable lugs to Feed 1 (Red) and RTN (Black).

6 Connect the loose end of the DC cable to the DC terminal on the RRH.

7 To connect the DC cable to the RRH, refer to the appropriate RRH installation manual.

9442 RRH installation manual:

- 9442 RRH (AWS) Installation manual, 418-000-426
- 9442 RRH (700 MHz- Lower Band) Installation manual, 418-000-424

END OF STEPS

Route and connect the AC cable

Overview

The following topic covers the routing and connection AC cable in the 9412 Compact cabinet.

Route and connect the AC cable in the BB cabinet

Perform the following steps to route and connect the three-wire AC cable to the Phoenix terminal blocks and ground point in the 9412 Compact cabinet.

- 1 Route and dress the cable from its conduit entry point, to the Phoenix terminal block location at the bottom front of the BB cabinet. Refer to the following figure.



AC Terminal Block Cover
(bottom right of BB cabinet)

- 2 Remove the cover from the AC terminal blocks. Refer to the following figure.

AC Terminal Block



- 3 Fan out the wires and lead them to the correct terminals. Refer to the following figure and table.

AC TERMINAL BLOCK CONNECTIONS

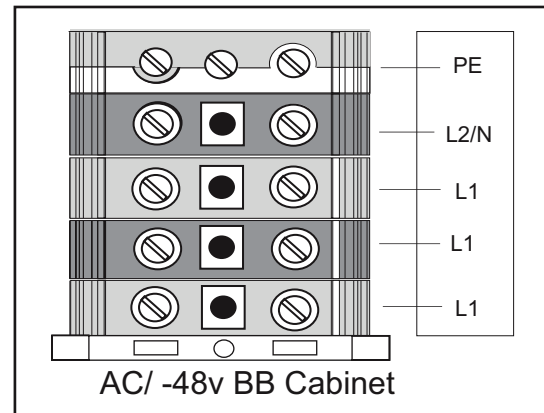
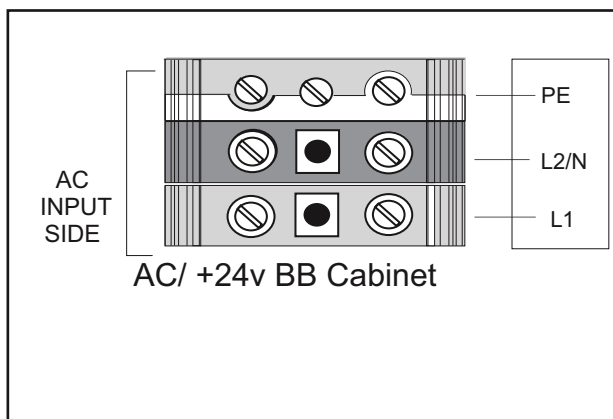

- 4 Route the 25 inch ground wire from the end of the AC cable to the AC terminal block.

- 5 Attach the ring terminal lug to the screw hole with the supplied M5 screw and connect the ground wire to the ground point on the AC terminal block.
- 6 Connect the AC wires (L1 and L2/N) to the Phoenix terminal blocks on the AC terminal as indicated in the table below. Refer to the [Step 3](#) figure for an illustration of the terminal blocks.

+24V Terminal Block			
AC cable wire color	Terminal block label	Function	Block Position and Color
North America and compatible markets			
Red	L1	L1	1 (Gray)
Black	L2/N	L2	2 (Blue)
Green	PE	GND	3 (Yellow/Green)

-48V Terminal Block		
Terminal block label	Function	Block Position and Color
L1	L1, L1,L1 (these terminals are jumpered)	1,2,3 (Gray)
L2/N	L2	4 (Blue)
PE	GND	5 (Yellow/Green)

- 7 Torque the screws to 1.5 to 1.8 Nm (13 to 16 in.-lb).

END OF STEPS

Final connections

Overview

Purpose

This section addresses the final connections to be made after installation of the eNodeB has been completed.

Contents

Initial start-up and system test	7-15
Final cabinet installation procedures	7-16

Initial start-up and system test

Important! The procedures for initial start-up and test are not covered in this document. Refer to *Integration Engineering Handbook*, IEH 401.

Before initial start-up and test

To perform initial start-up and system test, the RF jumper cables will be temporarily disconnected at the eNodeB by the personnel who perform initial start-up and system test.

After performing initial start-up and system test, the personnel will permanently connect the RF jumper cables to the eNodeB.

After initial start-up and test

NOTICE

RF hazard!

If it is necessary to disconnect an RF jumper cable, make sure there is no transmit signal in the RF jumper cable.

-
- 1 Once initial start-up and test have been completed, make sure the RF jumper cables are properly connected to the radio cabinet. Refer to Connect RF jumper cables to eNodeB on page 7-9.

-
- 2 **Important!** Hold the body of the 90 degree connector (part connected to the entry cable) with a 22 mm open-end wrench. Torque the rotating nut with a 32 mm open-end wrench.

Torque each RF connector at the radio cabinet to 25 Nm (221 in-lb).

-
- 3 Finally, secure the RF jumper cables along their route.

END OF STEPS

Final cabinet installation procedures

Overview

This topic describes the tasks that must be completed to finish installation of the eNodeB.

System test

Following installation of the eNodeB, the system should be tested before being put into operation. System test procedures are not covered in this installation document. Information concerning system test and integration is contained in *Integration Engineering Handbook (IEH) 401*.

Ensure that it is safe to turn on eNodeB

Use the following procedure to ensure the eNodeB can be turned on.

-
- 1 Inspect for loose tools, materials, and parts. Remove all such loose tools, materials, and parts.
 - 2 Verify that all the cable connections are secure.

END OF STEPS

Power up eNodeB

Use the following procedure to power up the eNodeB.

-
- 1 Turn on the DC circuit breakers at the DC power source.
 - 2 Turn on the AC heaters, if available.

END OF STEPS

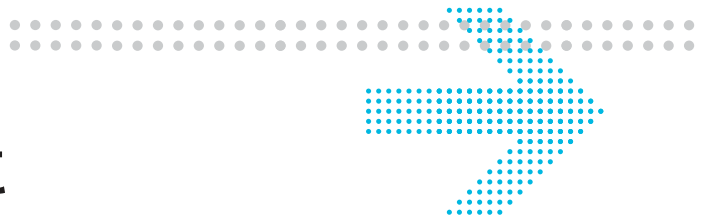

Appendix C: Product conformance statements

Overview

Purpose

This section presents the product conformance statements that apply to the eNodeB Compact cabinet.

In regions such as North America and the European Union, the statements that are required are determined primarily by national or multi-national regulations. However, in some regions, contract terms determine which statements are required.

The presence of the statement indicates that the product does comply with that statement wherever it is required to do so.

Contents

Canada	C-2
European Union	C-5
United States	C-9

Canada

Introduction

The statements that follow are the product conformance statements that apply to the 9412 eNodeB when deployed in Canada.

Industry Canada

ICES-003: Interference-Causing Equipment Standard Digital Apparatus

This Class A digital apparatus complies with Canadian ICES-003.

Cet appareil numérique de la classe A est conforme à la norme NMB-003 du Canada.

IC CS-03: Specification for Terminal Equipment, Terminal Systems, Network Protection Devices, Connection Arrangements and Hearing Aids Compatibility

This product meets the applicable Industry Canada technical specifications.

RF approval

- RSS-132: Cellular Telephones Employing New Technologies Operating in the Bands 824-849 MHz and 869-894 MHz
The term “IC” before the certification/registration number only signifies that the Industry Canada technical specifications were met.
- RSS-133: PCS Radio Standards Specifications
The term “IC” before the certification/registration number only signifies that the Industry Canada technical specifications were met.

Product safety conformance

This product is safety certified for Canada by a laboratory accredited by the Standards Council of Canada (SCC), such as CSA, UL, or others. The product bears this certification mark of this certification laboratory on its main nameplate label. Should the local authority having jurisdiction (AHJ) require prior or additional verification of this certification, a product certificate of compliance can be obtained from the specific certification laboratory by the business/product unit Applicant for the product.

Any modifications to this equipment are not permitted without review and written official authorization from the specific certification laboratory. Unauthorized changes may violate the product safety certification. Modifications or changes authorized by official CN/CNN are assumed to have received prior approval from this Lab.

The distributed cabinet has been listed with CSA to install only the following auxiliary equipment in the 9412 cabinet user space.

- Tellabs 8605 Access Switch
- Kathrein 860 10006 CCU (Central Control Unit for Remote Electrical Tilt) RET.

Antenna exposure

Antenna installations for the 9412 eNodeB shall be performed in accordance with all applicable manufacturer's recommendations, and national laws and regulations. To ensure correct antenna installation, the antenna installer shall perform all necessary calculations and/or field measurements to evaluate compliance with applicable national laws or regulations regarding exposure to electromagnetic fields. The supplier of radio equipment, the supplier of antenna equipment and the integrator and builder of the site must provide sufficient information so that the limits of the exclusion zones can be determined. Any changes to the antenna or other equipment in the transmit path may require re-evaluation of the exposures to electromagnetic fields.

Human exposure

Pursuant to Health Canada Safety Code 6, Limits of Human Exposure to Radio frequency Electromagnetic Fields in the Frequency Range from 3 kHz to 300 GHz, all installations must be evaluated against the Maximum Exposure Limits as described in Chapter 2, Health Canada 99-EHD-237.

Optical transmitters

Alcatel-Lucent declares that 9412 eNodeB complies with the International Electrotechnical Commission (IEC) standards IEC 60825-1 Edition 2.0 (2007) and IEC 60825-2 Edition 3.1 (2007). It is a Class I/1 laser optical fiber communication systems "product" under the IEC classifications.

This product is designed to ensure that personnel operating the product are not endangered by laser radiation during normal operation and fault conditions. This product does not present a risk of eye injury because it is fully enclosed and does not contain embedded lasers greater than Class I/1 unless otherwise noted.



Use of controls or adjustments or performance of procedures other than those specified herein may result in hazardous laser radiation exposure.

Do not view directly into the laser beam with optical instruments such as a fiber microscope because viewing of laser emission in excess of Class 1 limits significantly increases the risk of eye damage.

Never look into the end of an exposed fiber or an open connector as long as the optical source is switched on.

Ensure that the optical source is switched off before disconnecting optical fiber connectors.

Packaging collection and recovery requirements

Countries, states, localities, or other jurisdictions may require that systems be established for the return and/or collection of packaging waste from the consumer, or other end user, or from the waste stream. Additionally, reuse, recovery, and/or recycling targets for the return and/or collection of the packaging waste may be established.

For more information regarding collection and recovery of packaging and packaging waste within specific jurisdictions, please contact the Alcatel-Lucent Services - Environmental Health and Safety organization. For installations not performed by Alcatel-Lucent Technologies, please contact the Alcatel-Lucent Customer Support Center at:

Technical Support Services, within Canada: +1 630 224 4672, prompt 2

European Union

Introduction

The statements that follow are the product conformance statements that apply to the 9412 eNodeB bearing the CE Marking and when deployed in the European Union.

Declaration of Conformity for radio and telecommunication terminal equipment under the scope of Directive 1999/5/EC

Hereby, Alcatel-Lucent declares that the equipment documented in this publication is in compliance with the essential requirements and other relevant provisions of Directive 1999/5/EC.

The technical documentation as required by the Conformity Assessment procedure is kept at the Alcatel-Lucent location which is responsible for this product. For more information please contact your local Alcatel-Lucent Customer Service Organization.

CE marking

This product has been CE-marked in accordance with the following European Directive:

- Radio and Telecommunication Terminal Equipment (R&TTE) 1999/5/EC

EMC and radio spectrum compliance for the 850 MHz product

The equipment complies with the following EMC and radio spectrum specifications:

- EN 60950-1
- EN 60215

EMC and radio spectrum compliance for the 450 MHz product

The equipment complies with the following EMC and radio spectrum specifications:

- ETSI EN 301 449 V1.1.1 (2005-05)
- ETSI EN 301 489-1 V1.6.1 (2005-09)
- Code of Federal Regulations FCC part 24(E)
- IS 3GPP2 - C.S0010-B

Product safety conformance

The equipment complies with the following product safety specifications:

- EN 60950-1:2001
- EN 60215:1989

Telecommunications Standards

The equipment complies with the following telecommunication specifications:

- Technical Basis Regulation TBR 13

Antenna exposure

Antenna installations for the 9412 eNodeB shall be performed in accordance with all applicable manufacturer's recommendations, and national laws and regulations. To ensure correct antenna installation, the antenna installer shall perform all necessary calculations and/or field measurements to evaluate compliance with applicable national laws or regulations regarding exposure to electromagnetic fields. The supplier of radio equipment, the supplier of antenna equipment and the integrator and builder of the site must provide sufficient information so that the limits of the exclusion zones can be determined. Any changes to the antenna or other equipment in the transmit path may require re-evaluation of the exposures to electromagnetic fields.

Pursuant to

- European Council Recommendation 1999/519/EC “On the limitation of exposure of the general public to electromagnetic fields” dated 12 July 1999 and
- ICNIRP (International Commission on Non-Ionising Radiation Protection) “Guidelines for limiting exposure to time-varying electric, magnetic, and electromagnetic fields”,

all installations must be evaluated against the Reference Levels, and if necessary exclusion zones for public and installation workers defined.

The following information on Alcatel-Lucent supplied equipment is available from customer representatives:

- Output power and antenna characteristic, if the product is equipped with an integral antenna.
- A detailed description of at least one typical normal configuration, including antenna system (feeders, connectors, combiners, antennas etc.), if the product is intended to be used with external antennas.
- Limit distances for general public and occupational exposure. If the product is intended for use with external antennas, limit distances shall be given for the given typical system configurations.
- Information how to specify exposure levels and limit distances for any optional system configuration not specified in detail.
- Information on how to install the equipment/system or the external antennas in order to ensure that the separation between the radiating antenna and general public are exceeding the maximum allowed distances.

Information on the methodology used for the determination of RF safety compliance distances and exclusion zones, and the results of the compliance evaluation shall be available for inspection by officials of the governing authorities.

Optical transmitters

Alcatel-Lucent declares that 9412 eNodeB complies with the CENELEC standards EN 60825-1 Edition 1994 and its amendment 1 (2002) and amendment 2 (2001) and EN 60825-2 Edition 2004. It is a Class I/1 laser optical fiber communication systems “product” under the IEC classifications.

This product is designed to ensure that personnel operating the product are not endangered by laser radiation during normal operation and fault conditions. This product does not present a risk of eye injury because it is fully enclosed and does not contain embedded lasers greater than Class I/1 unless otherwise noted.



Use of controls or adjustments or performance of procedures other than those specified herein may result in hazardous laser radiation exposure.

Do not view directly into the laser beam with optical instruments such as a fiber microscope because viewing of laser emission in excess of Class 1 limits significantly increases the risk of eye damage.

Never look into the end of an exposed fiber or an open connector as long as the optical source is switched on.

Ensure that the optical source is switched off before disconnecting optical fiber connectors.

Packaging collection and recovery requirements

Countries, states, localities, or other jurisdictions may require that systems be established for the return and/or collection of packaging waste from the consumer, or other end user, or from the waste stream. Additionally, reuse, recovery, and/or recycling targets for the return and/or collection of the packaging waste may be established.

For more information regarding collection and recovery of packaging and packaging waste within specific jurisdictions, please contact the Alcatel-Lucent Services - Environmental Health and Safety organization. For installations not performed by Alcatel-Lucent Technologies, please contact the Alcatel-Lucent Customer Support Center at:

Technical Support Services, from all other countries: +1 630 224 4672, prompt 2

Recycling / take-back / disposal of product

Electronic products bearing or referencing the symbol shown below when put on the market within the European Union, shall be collected and treated at the end of their useful life, in compliance with applicable European Union and local legislation. They shall not be disposed of as part of unsorted municipal waste. Due to materials that may be contained in the product, such as heavy metals or batteries, the environment and human health may be negatively impacted as a result of inappropriate disposal.



Important! In the European Union, a solid bar under the crossed-out wheeled bin indicates that the product was put on the market after 13 August 2005.

Moreover, in compliance with legal requirements and contractual agreements, where applicable, Alcatel-Lucent will offer to provide for the collection and treatment of Alcatel-Lucent products bearing the logo at the end of their useful life, or products displaced by Alcatel-Lucent equipment offers. For information regarding take-back of equipment by Alcatel-Lucent, or for more information regarding the requirements for recycling/disposal of product, please contact your Alcatel-Lucent Account Manager or Alcatel-Lucent Takeback Support at:

takeback@alcatel-lucent.com.

Material content compliance

European Union (EU) Directive 2002/95/EC, “Restriction of the use of certain Hazardous Substances” (RoHS), restricts the use of lead, mercury, cadmium, hexavalent chromium, and certain flame retardants in electrical and electronic equipment. This Directive applies to electrical and electronic products placed on the EU market after 1 July 2006, with various exemptions, including an exemption for lead solder in network infrastructure equipment. Alcatel-Lucent products shipped to the EU after 1 July 2006 comply with the EU RoHS Directive.

United States

Introduction

The statements that follow are the product conformance statements that apply to the 9412 eNodeB when deployed in the United States.

Federal Communications Commission

Important! Changes or modifications not expressly approved by Alcatel-Lucent, Inc. could void the user's authority to operate the equipment.

FCC Part 15

This device complies with Part 15 of the FCC Rules. Operation is subject to the following two conditions: (1) This device may not cause harmful interference, and (2) this device must accept any interference received, including interference that may cause undesired operation.

FCC Part 15 Class A (as marketed)

Important! This equipment has been tested and found to comply with the limits for a Class A digital device, pursuant to Part 15 of the FCC Rules. These limits are designed to provide reasonable protections against harmful interference when the equipment is operated in a commercial environment. This equipment generates, uses, and can radiate radio frequency energy and, if not installed and used in accordance with the instruction manual, may cause harmful interference to radio communications. Operation of this equipment in a residential area is likely to cause harmful interference, in which case the user will be required to correct the interference at the user's expense.

FCC Part 15 Class B (as marketed)

Important! This equipment has been tested and found to comply with the limits for a Class B digital device, pursuant to Part 15 of the FCC Rules. These limits are designed to provide reasonable protection against harmful interference in a residential installation. This equipment generates, uses, and can radiate radio frequency energy and, if not installed and used in accordance with the instructions, may cause harmful interference to radio communications. However, there is no guarantee that interference will not occur in a particular installation. If this equipment does cause harmful interference to radio or television reception, which can be determined by turning the equipment off and on, the user is encouraged to try to correct the interference by one or more of the following measures:

- Reorient or relocate the receiving antenna
- Increase the separation between the equipment and receiver

-
- Connect the equipment into an outlet on a circuit different from that to which the receiver is connected
 - Consult the dealer or an experienced radio/TV technician for help.

FCC Part 68

This equipment complies with Part 68 of the FCC rules and the requirements adopted by the ACTA. On the cabinet assembly of this equipment is a label that contains, among other information, a product identifier in the format of AAAEQ##TXXXX. If requested, this number must be provided to the telephone company.

- FIC 04DU9-1SN
- SOC 6.0N

The T1 network interface on this equipment is hard wired to a punchdown block , which meets the FCC specifications.

If this equipment 9412 eNodeB causes harm to the telephone network, the telephone company will notify you in advance that temporary discontinuance of service may be required. However, if advance notice is not practical, the telephone company will notify the customer as soon as possible. Also, you will be advised of your right to file a complaint with the FCC if you believe it is necessary.

The telephone company may make changes in its facilities, equipment, operations, or procedures that could affect the operation of the equipment. If this happens, the telephone company will provide advance notice in order for you to make necessary modifications to maintain uninterrupted service.

FCC regulations prohibit the connection of customer-provided equipment to central office implemented systems. Connection to party lines is subject to tariffs; users should contact their state public utility commission, public service commission, or corporation commission for information.

If the equipment is causing harm to the telephone network, the telephone company may request that you disconnect the equipment until the problem is resolved.

If trouble is experienced with this equipment repair or warranty information may be obtained by contacting:

Technical Support Services, within the United States: +1 630 224 4762, prompt 2

RF approval

This equipment complies with Part 2, Subpart J - Equipment Authorization Procedures, of the FCC Rules.

This device complies with Part 27-Miscellaneous Wireless Communications services.

This device complies with Part 90-Public Safety 700 MHz Nationwide Broadband Network.

FDA/IEC optical transmitter product compliance

Alcatel-Lucent declares that 9412 eNodeB complies with the Food and Drug Administration's Center for Devices and Radiological Health (FDA/CDRH) regulations 21 CFR 1040.10 and 1040.11. It is a Class I/1 laser optical fiber communication systems "product" under the FDA.

This Product is designed to ensure that personnel operating the product are not endangered by laser radiation during normal operation and fault conditions. This product does not present a risk of eye injury because it is fully enclosed and does not contain embedded lasers greater than Class I/1 unless otherwise noted.



Use of controls or adjustments or performance of procedures other than those specified herein may result in hazardous laser radiation exposure.

Do not view directly into the laser beam with optical instruments such as a fiber microscope because viewing of laser emission in excess of Class 1 limits significantly increases the risk of eye damage.

Never look into the end of an exposed fiber or an open connector as long as the optical source is switched on.

Ensure that the optical source is switched off before disconnecting optical fiber connectors.

Product safety conformance

This product is safety listed for the United States of America by a Nationally Recognized Test Laboratory (NRTL) accredited by the US Department of Labor, Occupational Safety and Health Administration (OSHA), such as UL, CSA, or others. The product bears this certification mark of this certification laboratory on its main nameplate label. Should the local authority having jurisdiction (AHJ) require prior or additional verification of this certification, a product certificate of compliance can be obtained from the specific certification laboratory by the business/product unit Applicant for the product. "Any modifications to this equipment are not permitted without review and written official authorization from the specific certification laboratory. Unauthorized changes may violate the product safety certification. Modifications or changes authorized by official CN/CNN are assumed to have received prior approval from this Lab.

Baseband cabinet user space

The user space provided in the Baseband cabinet may be used for installing customer specified equipment. However, the equipment must have been tested in the 9412 eNodeB to FCC Part 15 (B) and met Class B requirements. Such an installation is subject to the non-interference requirements of Section 15.5 and Part 2.953(d) of FCC rules.

Antenna exposure

Antenna installations for the 9412 eNodeB shall be performed in accordance with all applicable manufacturer's recommendations, and national laws and regulations. To ensure correct antenna installation, the antenna installer shall perform all necessary calculations and/or field measurements to evaluate compliance with applicable national laws or regulations regarding exposure to electromagnetic fields. The supplier of radio equipment, the supplier of antenna equipment and the integrator and builder of the site must provide sufficient information so that the limits of the exclusion zones can be determined. Any changes to the antenna or other equipment in the transmit path may require re-evaluation of the exposures to electromagnetic fields.

Pursuant to 47 CFR Part 1, Subpart I, subject to the provisions of section 1.1307, all installations must be evaluated for requirements contained in Table 1, "Limits for maximum permissible exposure," in section 1.1310.

Packaging collection and recovery requirements

Countries, states, localities, or other jurisdictions may require that systems be established for the return and/or collection of packaging waste from the consumer, or other end user, or from the waste stream. Additionally, reuse, recovery, and/or recycling targets for the return and/or collection of the packaging waste may be established.

For more information regarding collection and recovery of packaging and packaging waste within specific jurisdictions, please contact the Alcatel-Lucent Services - Environmental Health and Safety organization. For installations not performed by Alcatel-Lucent Technologies, please contact the Alcatel-Lucent Customer Support Center at:

Technical Support Services, within the United States: +1 630 224 4762, prompt 2

Material content compliance

The following notification applies to Alcatel-Lucent products distributed for sale, resale or use.

This product, part, or both may include a lithium-manganese dioxide battery, which contains very small amounts of a perchlorate substance. Special handling may apply.

For California:

Perchlorate Material - special handling may apply.

See <http://www.dtsc.ca.gov/hazardouswaste/perchlorate/>

