

TIMCO ENGINEERING INC.

849 NW State Road 45

Newberry, Florida 32669

<http://www.timcoengr.com>

888.472.2424 F 352.472.2030 email: sid@timcoengr.com



Test Report

Product Name: UHF LAND MOBILE RADIO

FCC ID: ARURPU499A

Applicant:

**RELM WIRELESS CORPORATION
7100 TECHNOLOGY DRIVE
W. MELBOURNE, FLORIDA 32904**

DBA RELM COMMUNICATIONS INC.

Date Receipt: FEBRUARY 17, 2004

Date Tested: FEBRUARY 26, 2004

APPLICANT: RELM WIRELESS CORPORATION

FCC ID: ARURPU499A

REPORT #: R\RELM_ARU\191AUT4\191AUT4TestReport.doc

COVER SHEET

TIMCO ENGINEERING INC.

849 NW State Road 45
Newberry, Florida 32669
<http://www.timcoengr.com>
888.472.2424 F 352.472.2030 email: sid@timcoengr.com

TABLE OF CONTENTS LIST

APPLICANT: RELM WIRELESS CORPORATION

FCC ID: ARURPU499A

TEST REPORT:

PAGE 1.....	GENERAL INFORMATION & TECHNICAL DESCRIPTION
PAGE 2.....	TECHNICAL DESCRIPTION CONTINUED RF POWER OUTPUT
PAGE 3.....	MODULATION CHARACTERISTICS AUDIO FREQUENCY RESPONSE
PAGE 4.....	MODULATION LIMITING PLOT
PAGE 5.....	AUDIO LOW PASS FILTER
PAGE 6-7.....	OCCUPIED BANDWIDTH
PAGE 8-11.....	OCCUPIED BANDWIDTH PLOTS
PAGE 12.....	SPURIOUS EMISSIONS AT ANTENNA TERMINALS METHOD OF MEASURING SPURIOUS EMISSIONS AT ANTENNA TERMINALS
PAGE 13-15.....	FIELD STRENGTH OF SPURIOUS EMISSIONS
PAGE 16.....	METHOD OF MEASURING RADIATED SPURIOUS EMISSIONS
PAGE 17.....	FREQUENCY STABILITY
PAGE 18-19.....	TRANSIENT FREQUENCY STABILITY
PAGE 20-21.....	TRANSIENT FREQUENCY RESPONSE GRAPHS
PAGE 22-25.....	EQUIPMENT LIST

EXHIBITS CONTAINING:

BLOCK DIAGRAM
SCHEMATIC
PARTS LIST
USERS MANUAL
LABEL SAMPLE
LABEL LOCATION
EXTERNAL PHOTOGRAPHS
INTERNAL PHOTOGRAPHS
ALIGNMENT PROCEDURE
OPERATIONAL DESCRIPTION
TEST SET UP PHOTOGRAPH

APPLICANT: RELM WIRELESS CORPORATION

FCC ID: ARURPU499A

REPORT #: R\RELM_ARU\191AUT4\191AUT4TestReport.doc

TABLE OF CONTENTS

TIMCO ENGINEERING INC.

849 NW State Road 45
Newberry, Florida 32669
<http://www.timcoengr.com>
888.472.2424 F 352.472.2030 email: sid@timcoengr.com

GENERAL INFORMATION REQUIRED FOR TYPE ACCEPTANCE

2.1033(c)(1)(2) RELM WIRELESS CORPORATION will manufacture the FCCID: ARURPU499A VHF TRANSCEIVER in quantity, for use under FCC RULES PART 90.

RELM WIRELESS CORPORATION
7100 TECHNOLOGY DRIVE
W. MELBOURNE, FLORIDA 32904

2.1033(c) TECHNICAL DESCRIPTION

2.1033(c)(3) Instruction book. A draft copy of the instruction manual is included in the exhibits.

2.1033(c)(4) Type of Emission: 9K8F3E
90.209

Bn = 2M + 2DK
M = 3000
D = 2500
Bn = 2(3000)+2(1900) = 9.8k

90.209 Authorized Bandwidth 11.25 kHz

2.1033(c)(4) Type of Emission: 13K0F3E
90.209

Bn = 2M + 2DK
M = 3000
D = 5000
Bn = 2(3000)+2(2500) = 13k

90.209 Authorized Bandwidth 20 kHz

2.1033(c)(5) Frequency Range: 450 - 470 MHz
90.209

90.203 This equipment meets the requirements of the FCC Rules, Part 90.203(e) except as provided in paragraph (g) of the section 203. The operator cannot program and transmit on frequencies other than those programmed by the manufacturer, service or maintenance personnel, using the equipment's external operational controls.

2.1033(c)(8) DC Voltages and Current into Final Amplifier:
POWER INPUT:

FINAL AMPLIFIER ONLY
INPUT POWER - HIGH: (7.2V)(0.750A) = 5.4 Watts

APPLICANT: RELM WIRELESS CORPORATION
FCC ID: ARURPU499A
REPORT #: R\RELM_ARU\191AUT4\191AUT4TestReport.doc

TIMCO ENGINEERING INC.

849 NW State Road 45
Newberry, Florida 32669
<http://www.timcoengr.com>

888.472.2424 F 352.472.2030 email: sid@timcoengr.com

INPUT POWER - LOW: $(7.2V)(0.30A) = 2.2 \text{ Watts}$

- 2.1033(c)(9) Tune-up procedure. The tune-up procedure is included in the exhibits.
- 2.1033(c)(10) Complete Circuit Diagrams: The circuit diagram and block diagram are included in the exhibits.
 - (11) Function of each electron tube or semiconductor device or other active circuit device is included in the exhibits.
 - (12) Description of all circuitry and devices provided for determining and stabilizing frequency is included in the circuit description.
- 2.1033(c)(13) A photograph or drawing of the equipment identification label is shown in the exhibits.
- 2.1033(c)(14) Photographs of the equipment of sufficient clarity to reveal equipment construction and layout and label location are shown in the exhibits.
- 2.1033(c)(15) Digital Modulation is not allowed.
- 2.1033(c)(16) The data required for 2.1046 through 2.1057 is submitted below.

2.1046(a)

RF POWER OUTPUT

RF power is measured by connecting a 50-ohm, resistive wattmeter to the RF output connector. With a nominal battery voltage of 7.2 VDC, and the transmitter properly adjusted the RF output measures:

OUTPUT POWER: HIGH - 4.25 Watts Conducted
 LOW - 1.0 Watts Conducted

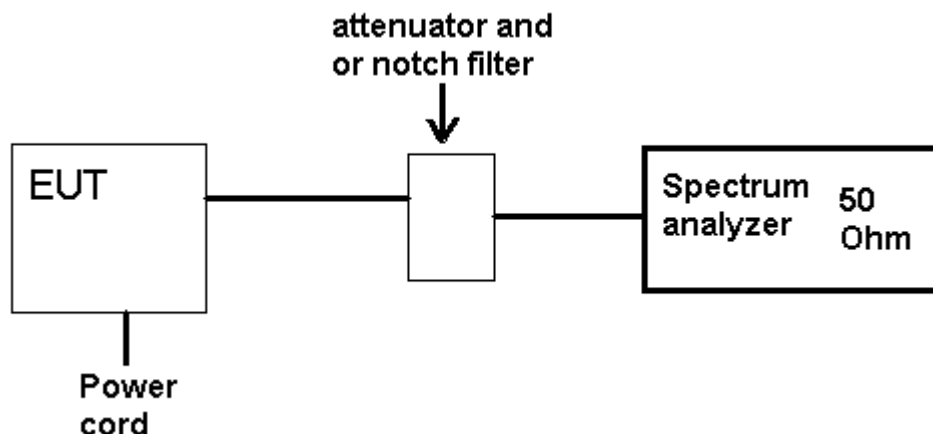

APPLICANT: RELM WIRELESS CORPORATION

FCC ID: ARURPU499A

REPORT #: R\RELM_ARU\191AUT4\191AUT4TestReport.doc

TIMCO ENGINEERING INC.

849 NW State Road 45

Newberry, Florida 32669

<http://www.timcoengr.com>

888.472.2424 F 352.472.2030 email: sid@timcoengr.com

2.1047(a)(b)

Modulation characteristics:

AUDIO FREQUENCY RESPONSE

The audio frequency response was measured in accordance with TIA/EIA Specification 603. The audio frequency response curve is shown below. The audio signal was fed into a dummy microphone circuit and into the microphone connector. The input required to produce 30 percent modulation level was measured.

AUDIO FREQUENCY RESPONSE PLOT

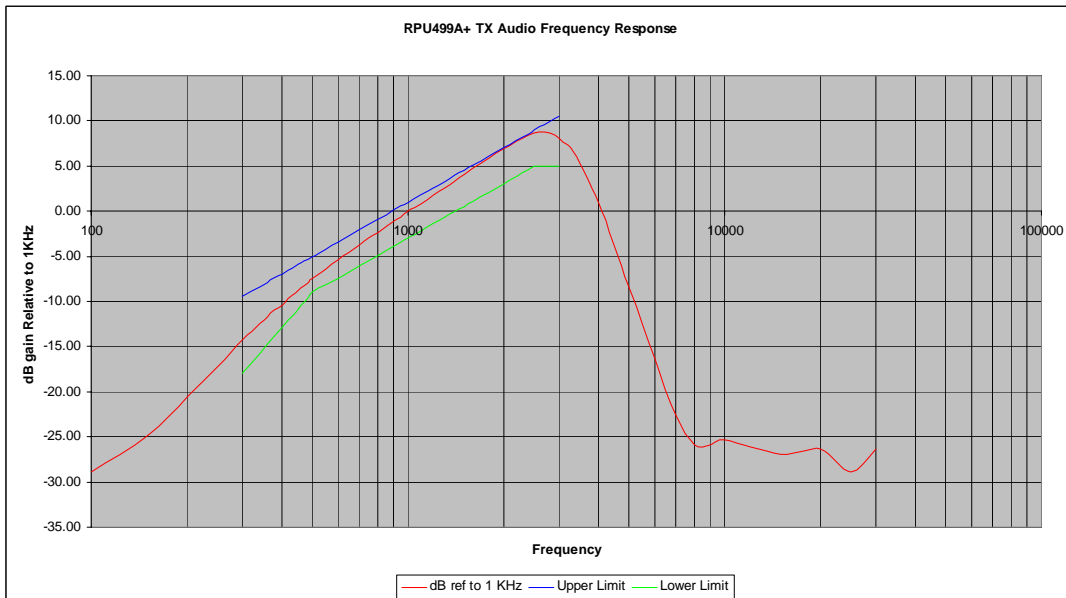
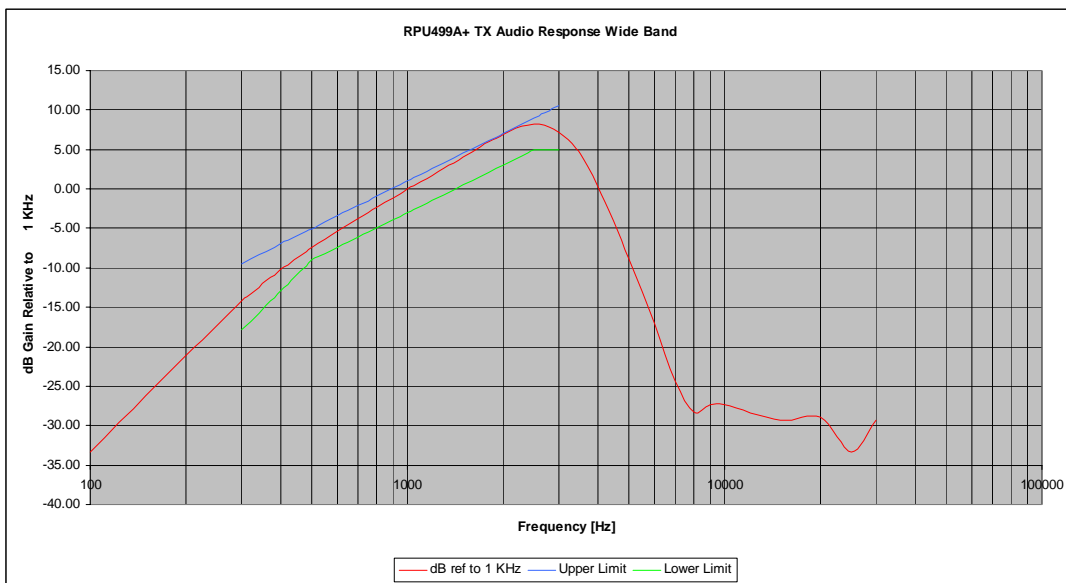

APPLICANT: RELM WIRELESS CORPORATION

FCC ID: ARURPU499A

REPORT #: R\RELM_ARU\191AUT4\191AUT4TestReport.doc

TIMCO ENGINEERING INC.

849 NW State Road 45

Newberry, Florida 32669

<http://www.timcoengr.com>

888.472.2424 F 352.472.2030 email: sid@timcoengr.com

2.1047(b)

Audio input versus modulation

The audio input level needed for a particular percentage of modulation was measured in accordance with TIA/EIA Specification 603. The audio input curves versus modulation are shown below. Curves are provided for audio input frequencies of 300, 1000, 2000, and 3000 Hz.

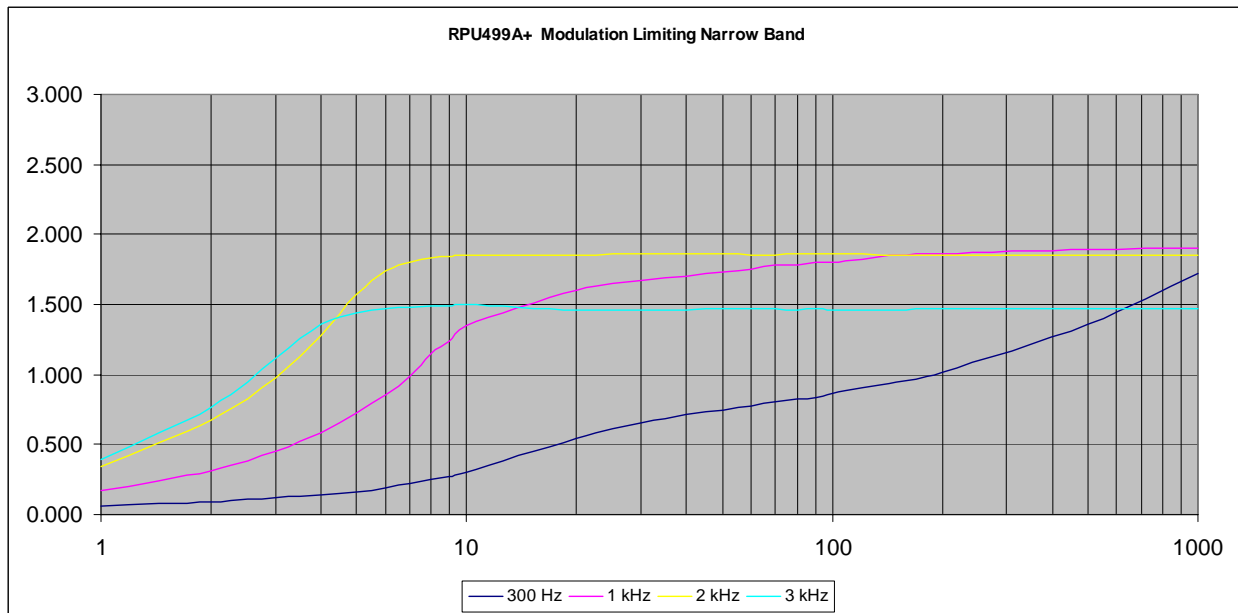
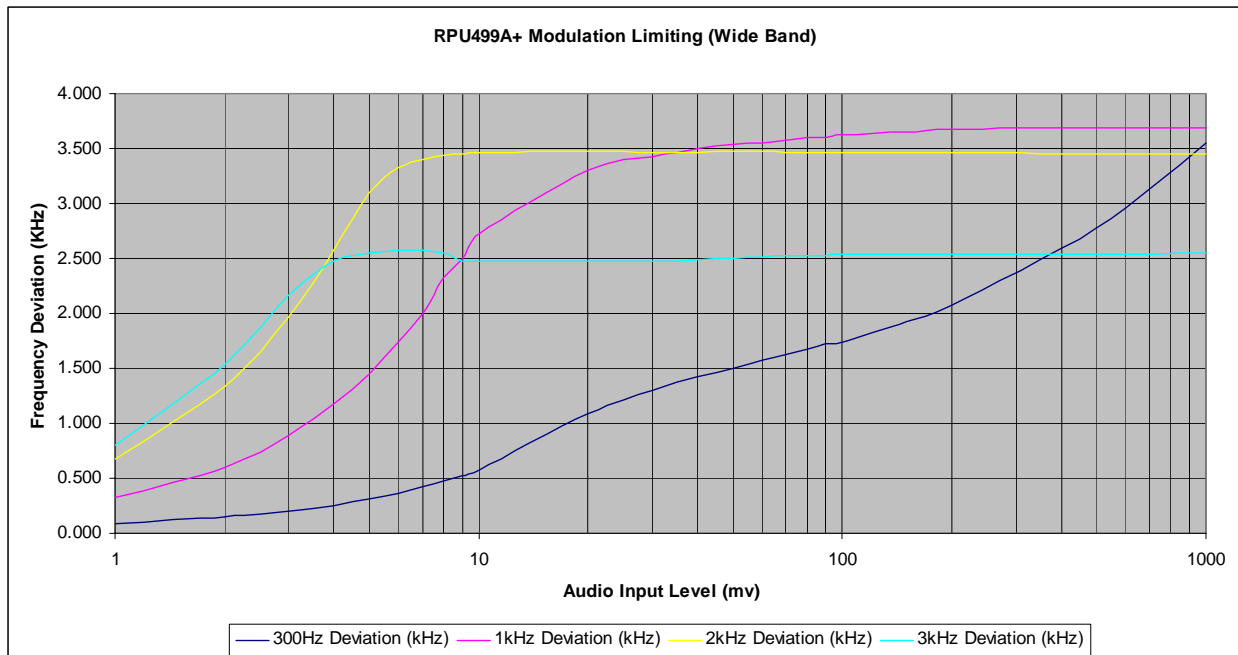

APPLICANT: RELM WIRELESS CORPORATION

FCC ID: ARURPU499A

REPORT #: R\RELM_ARU\191AUT4\191AUT4TestReport.doc

TIMCO ENGINEERING INC.

849 NW State Road 45
Newberry, Florida 32669
<http://www.timcoengr.com>
888.472.2424 F 352.472.2030 email: sid@timcoengr.com

Post Limiter Filter

The filter must be between the modulation limiter and the modulated stage. At any frequency between 3 & 20 kHz the filter must have an attenuation of $60\log(f/3)$ greater than the attenuation at 1kHz. See the plot below.

AUDIO LOW PASS FILTER

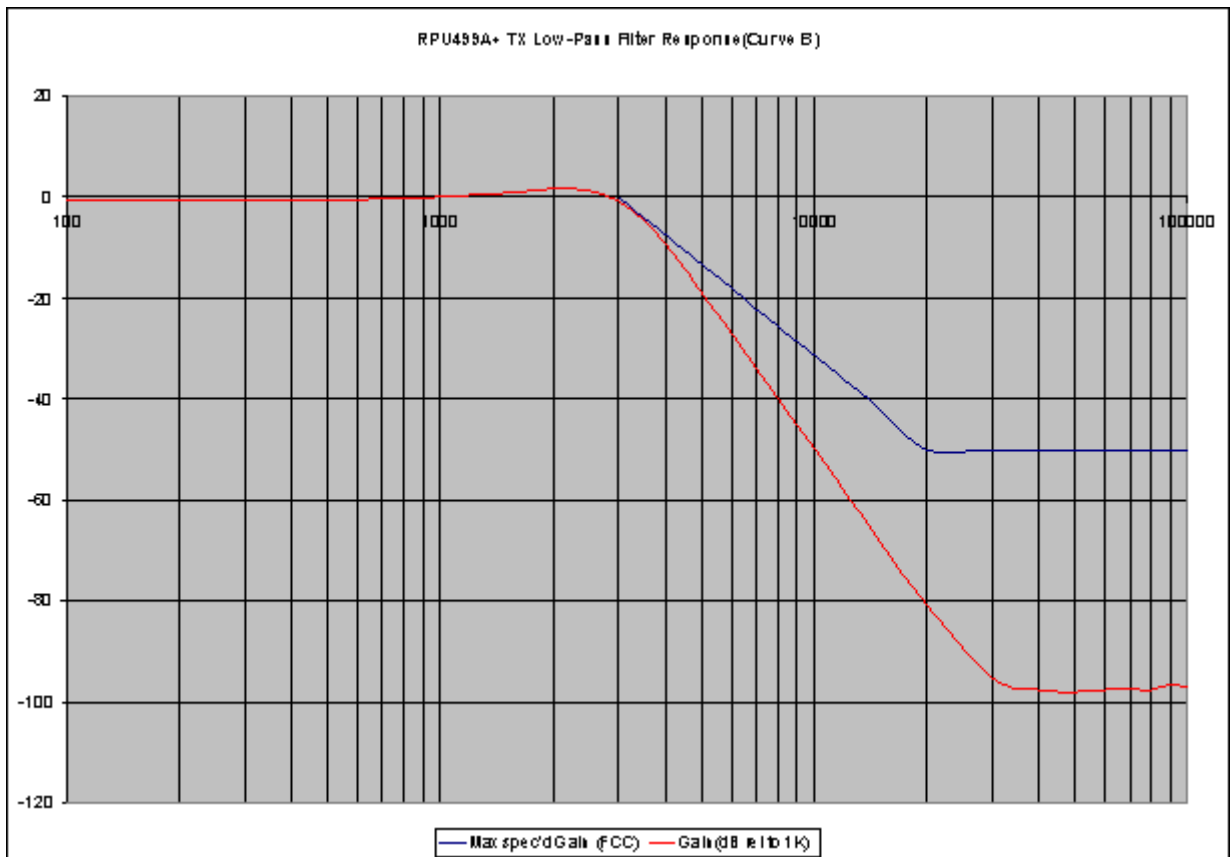

TIMCO ENGINEERING INC.

849 NW State Road 45

Newberry, Florida 32669

<http://www.timcoengr.com>

888.472.2424 F 352.472.2030 email: sid@timcoengr.com

2.1049(c) **EMISSION BANDWIDTH:**
90.210(b)

Emission Mask B - 25 kHz channel bandwidth equipment. Data in the plots shows that the sidebands from greater than 50% to 100% of the authorized bandwidth must be attenuated by at least 25 dB and from 100 to 250% the sidebands must be attenuated by at least 35 dB. Beyond 250% the sidebands must be attenuated by at least $43 + \log_{10}(TP)$. The transmitter was modulated with 2500 Hz, adjusted for 50% modulation plus 16 dB. The spectrum analyzer was set with the un-modulated carrier at the top of the screen. The test procedure diagram follows. See the occupied bandwidth plot on the next page.

90.210(d) Emission Mask D - 12.5 kHz channel bandwidth equipment. For transmitters designed to operate with a 12.5 kHz channel bandwidth, any emission must be attenuated below the power (P) of the highest emission contained within the authorized bandwidth as follows:

- (1) On any frequency from the center of the authorized bandwidth f_0 to 5.625 kHz removed from f_0 : Zero dB.
- (2) On any frequency from the center of the authorized bandwidth by a displacement frequency (f_d in kHz) of more than 5.625 kHz but no more than 12.5 kHz: At least $7.27 (f_d - 2.88 \text{ kHz})$ dB.
- (3) On any frequency removed from the center of the authorized bandwidth by a displacement frequency (f_d in kHz) of more than 12.5 kHz: At least $50 + 10\log(P)$ dB or 70 dB, whichever is the lesser attenuation.

Data in the plots show that the EUT complies with both narrow band and wide band requirements.

TIMCO ENGINEERING INC.

849 NW State Road 45

Newberry, Florida 32669

<http://www.timcoengr.com>

888.472.2424 F 352.472.2030 email: sid@timcoengr.com

Radiotelephone transmitter with modulation limiter:

Test procedure diagram

OCCUPIED BANDWIDTH MEASUREMENT

Occupied BW Test Equipment Setup

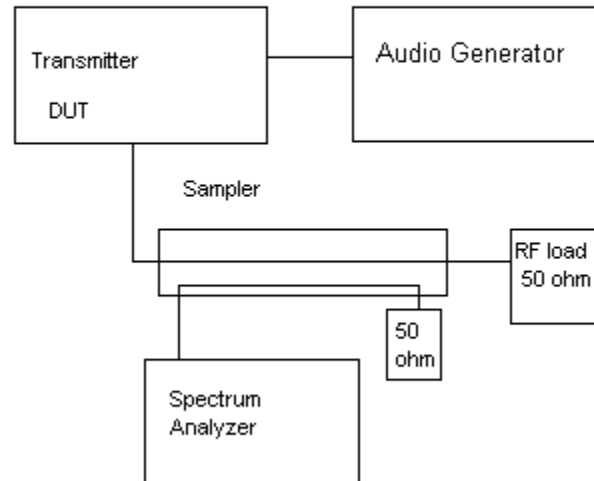

APPLICANT: RELM WIRELESS CORPORATION

FCC ID: ARURPU499A

REPORT #: R\RELM_ARU\191AUT4\191AUT4TestReport.doc

TIMCO ENGINEERING INC.

849 NW State Road 45

Newberry, Florida 32669

<http://www.timcoengr.com>

888.472.2424 F 352.472.2030 email: sid@timcoengr.com

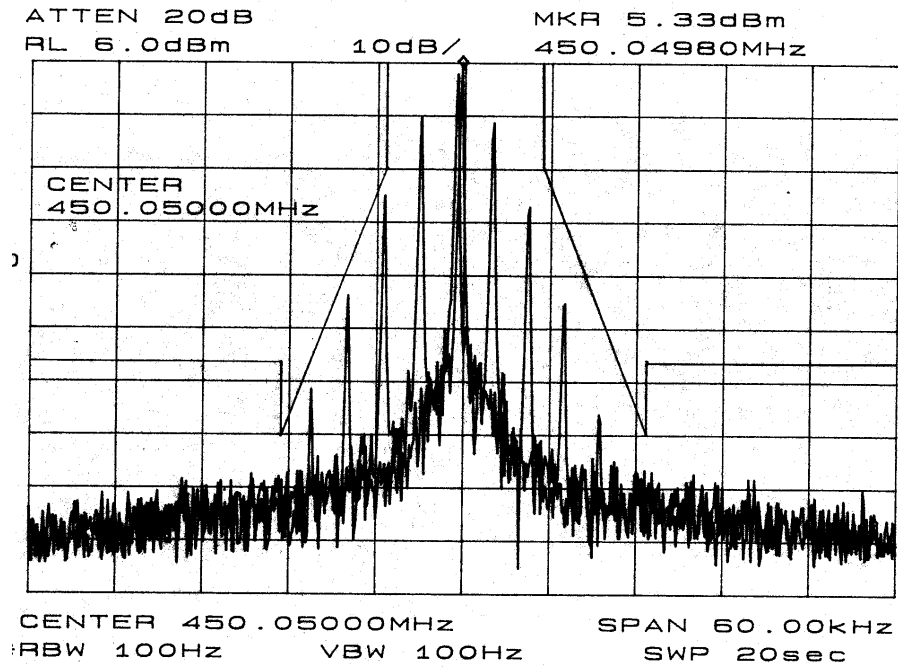

Graph 7 - Occupied Bandwidth in Narrow Band mode (12.5 KHz) at 450.050 MHz

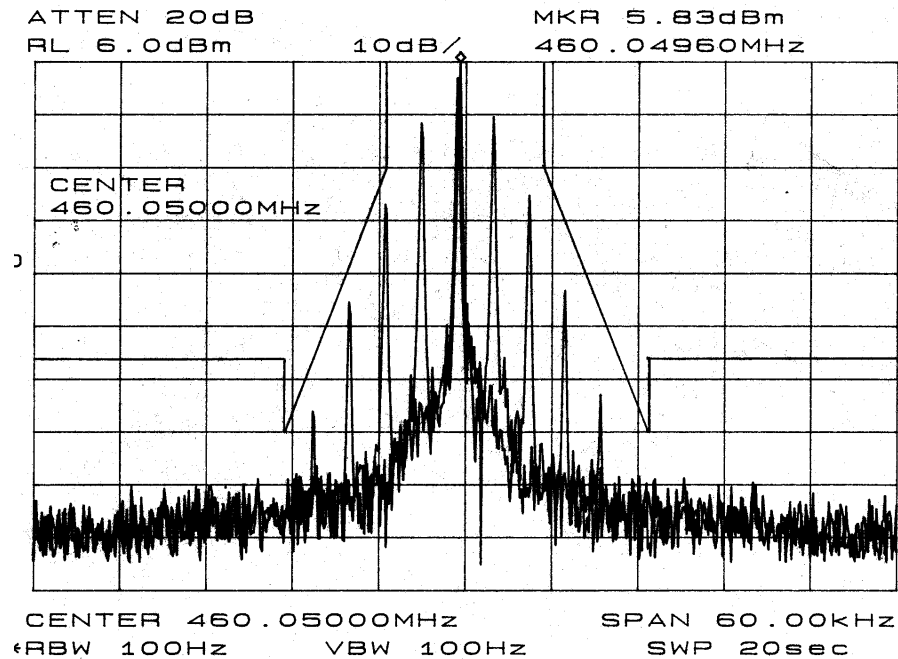

Graph 8 - Occupied Bandwidth in Narrow Band mode (12.5 KHz) at 460.050 MHz

APPLICANT: RELM WIRELESS CORPORATION

FCC ID: ARURPU499A

REPORT #: R\RELM_ARU\191AUT4\191AUT4TestReport.doc

TIMCO ENGINEERING INC.

849 NW State Road 45

Newberry, Florida 32669

<http://www.timcoengr.com>

888.472.2424 F 352.472.2030 email: sid@timcoengr.com

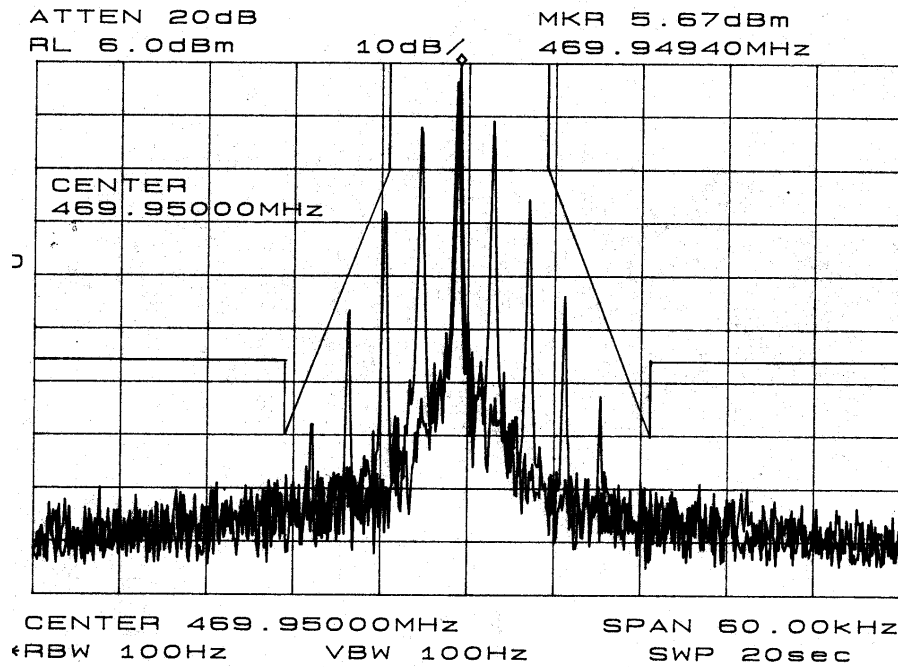

Graph 9 - Occupied Bandwidth in Narrow Band mode (12.5 KHz) at 469.950 MHz

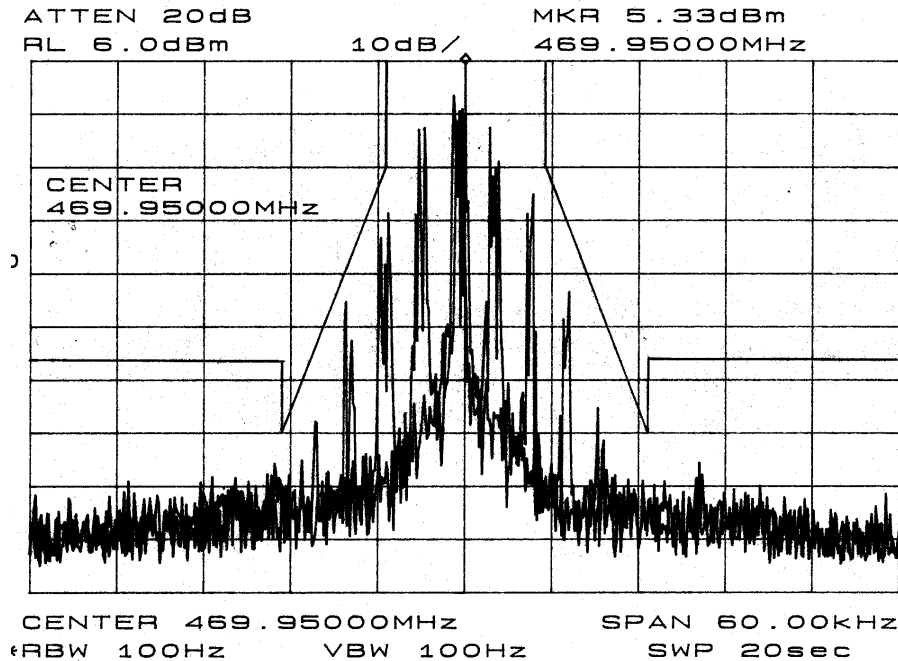

Graph 10 - Occupied Bandwidth with DCS in Narrow Band mode (12.5 KHz) at 469.950 MHz

APPLICANT: RELM WIRELESS CORPORATION

FCC ID: ARURPU499A

REPORT #: R\RELM_ARU\191AUT4\191AUT4TestReport.doc

TIMCO ENGINEERING INC.

849 NW State Road 45
Newberry, Florida 32669
<http://www.timcoengr.com>
888.472.2424 F 352.472.2030 email: sid@timcoengr.com

2.1051

Spurious emissions at antenna terminals (conducted):

Data below shows the level of conducted spurious responses. The carrier was modulated 100% using a 2500 Hz tone. The spectrum was scanned from 0.4 to at least the 10th harmonic of the fundamental. The measurements were made in accordance with standard TIA/EIA-603.

REQUIREMENTS:

Emissions must be $50 + 10\log(P_o)$ dB below the mean power output of the transmitter.

Freq.(MHz.)	Spur(dBW)
450.05	-101
460.05	-95
469.95	-93

Method of Measuring Conducted Spurious Emissions

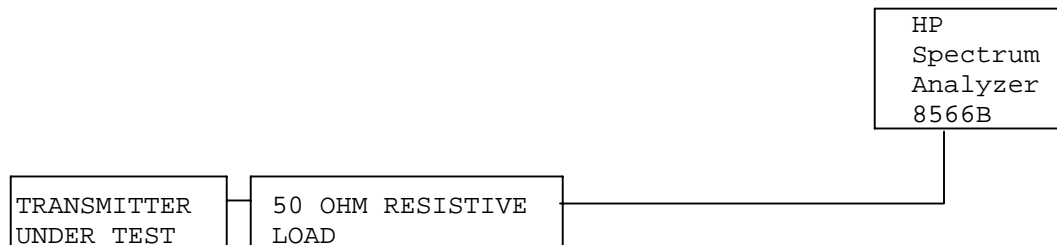

METHOD OF MEASUREMENT: The procedure used was TIA/EIA-603 STANDARD without any exceptions. An audio generator was connected to the UUT through a dummy microphone circuit and the output of the transmitter connected to a standard load and from the standard load through a pre-selector filter of the spectrum analyzer. The spectrum was scanned from 400 kHz to at least the tenth harmonic of the fundamental using a HP model 8566B spectrum analyzer. The measurements were made using the shielded room located at TIMCO ENGINEERING INC. 849 N.W. State Road 45, Newberry, Florida 32669.

TIMCO ENGINEERING INC.

849 NW State Road 45
Newberry, Florida 32669
http://www.timcoengr.com
888.472.2424 F 352.472.2030 email: sid@timcoengr.com

2.1053 **Field strength of spurious emissions:**

NAME OF TEST: RADIATED SPURIOUS EMISSIONS (460 MHz)

REQUIREMENTS: Emissions must be $43 + 10\log(P_o)$ dB below the mean power output of the transmitter.

 HIGH: $50 + 10\log(4.25) = 56.28$ dB
 LOW: $50 + 10\log(1.00) = 50.00$ dB

TEST DATA (HIGH):

Emission Frequency MHz	Ant. Polarity	Corrected EUT Signal Reading	Coax Loss (dB)	Substitution Antenna (dBd)	dB Below Carrier (dBc)
460.00	V	37.9	0	0.00	0.00
920.00	V	-29.2	0	-0.79	67.89
1380.00	H	-38.1	1.08	4.47	72.61
1840.00	H	-46.6	1.17	5.15	80.52
2300.00	V	-33.5	1.26	6.21	66.45
2760.00	H	-57.5	1.33	7.06	89.67
3220.00	V	-39.5	1.37	7.38	71.39
3680.00	H	-41.8	1.42	7.55	73.57
4140.00	H	-50.4	1.46	7.77	81.99
4600.00	H	-37.9	1.52	8.23	69.09

TEST DATA (LOW):

Emission Frequency MHz	Ant. Polarity	Corrected EUT Signal Reading	Coax Loss (dB)	Substitution Antenna (dBd)	dB Below Carrier (dBc)
460.00	V	32.0	0	0.00	0.00
920.00	V	-28.8	0	-0.79	61.59
1380.00	V	-34.7	1.08	4.47	63.31
1840.00	V	-40.2	1.17	5.15	68.22
2300.00	H	-50.0	1.26	6.21	77.05
2760.00	H	-55.9	1.33	7.06	82.17
3220.00	V	-40.6	1.37	7.38	66.59
3680.00	H	-42.6	1.42	7.55	68.47
4140.00	H	-54.6	1.46	7.77	80.29
4600.00	H	-48.1	1.52	8.23	73.39

APPLICANT: RELM WIRELESS CORPORATION
FCC ID: ARURPU499A
REPORT #: R\RELM_ARU\191AUT4\191AUT4TestReport.doc

TIMCO ENGINEERING INC.

849 NW State Road 45
Newberry, Florida 32669
<http://www.timcoengr.com>
888.472.2424 F 352.472.2030 email: sid@timcoengr.com

2.1053 **Field strength of spurious emissions:**

NAME OF TEST: RADIATED SPURIOUS EMISSIONS (469.9 MHz)

REQUIREMENTS: Emissions must be $43 + 10\log(P_o)$ dB below the
mean power output of the transmitter.

HIGH: $50 + 10\log(4.29) = 56.28$ dB

LOW: $50 + 10\log(1.00) = 50.00$ dB

TEST DATA (HIGH):

Emission Frequency MHz	Ant. Polarity	Corrected EUT Signal Reading	Coax Loss (dB)	Substitution Antenna (dBd)	dB Below Carrier (dBc)
469.90	V	38.7	0	0.00	0.00
939.80	V	-26.7	0	-1.03	66.43
1409.70	V	-36.4	1.08	4.59	71.59
1879.60	H	-43.7	1.18	5.18	78.40
2349.50	H	-40.6	1.27	6.37	74.20
2819.40	H	-54.2	1.33	7.11	87.12
3289.30	V	-40.7	1.38	7.42	73.36
3759.20	V	-42.2	1.43	7.55	74.78
4229.10	H	-42.2	1.47	7.92	74.45
4699.00	H	-35.0	1.54	8.11	67.13

TEST DATA (LOW):

Emission Frequency MHz	Ant. Polarity	Corrected EUT Signal Reading	Coax Loss (dB)	Substitution Antenna (dBd)	dB Below Carrier (dBc)
469.90	V	33.9	0	0.00	0.00
939.80	V	-25.6	0	-1.03	60.53
1409.70	H	-30.5	1.08	4.59	60.89
1879.60	V	-40.0	1.18	5.18	69.90
2349.50	V	-42.8	1.27	6.37	71.60
2819.40	H	-57.0	1.33	7.11	85.12
3289.30	V	-38.4	1.38	7.42	66.26
3759.20	H	-40.6	1.43	7.55	68.38
4229.10	H	-51.6	1.47	7.92	79.05
4699.00	H	-44.2	1.54	8.11	71.53

APPLICANT: RELM WIRELESS CORPORATION

FCC ID: ARURPU499A

REPORT #: R\RELM_ARU\191AUT4\191AUT4TestReport.doc

TIMCO ENGINEERING INC.

849 NW State Road 45

Newberry, Florida 32669

<http://www.timcoengr.com>

888.472.2424 F 352.472.2030 email: sid@timcoengr.com

Method of Measuring Radiated Spurious Emissions

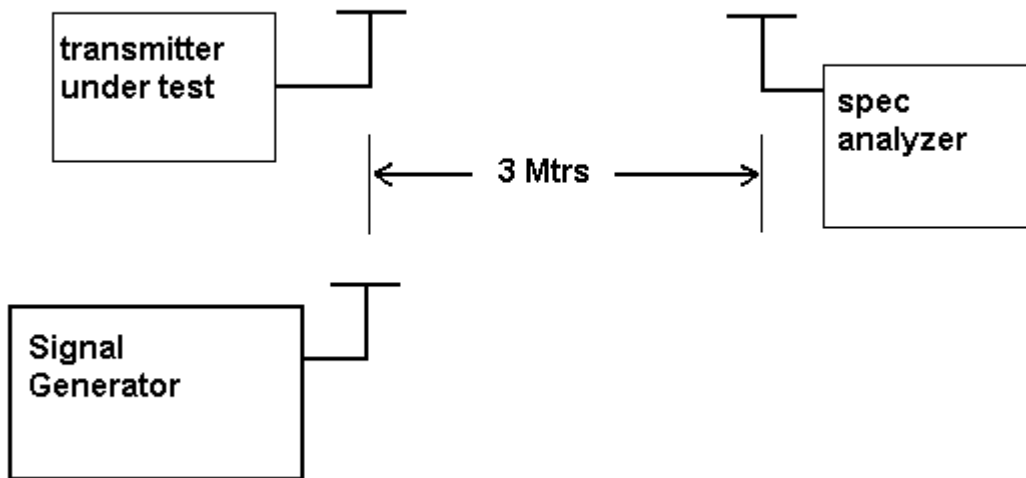

METHOD OF MEASUREMENTS: The tabulated data shows the results of the radiated field strength emissions test. The spectrum was scanned from 30 MHz to at least the tenth harmonic of the fundamental. This test was conducted per TIA/EIA STANDARD 603 using the substitution method. Measurements were made at the open field test site of TIMCO ENGINEERING, INC. located at 849 NW State Road 45, Newberry, FL 32669.

APPLICANT: RELM WIRELESS CORPORATION

FCC ID: ARURPU499A

REPORT #: R\RELM_ARU\191AUT4\191AUT4TestReport.doc

TIMCO ENGINEERING INC.

849 NW State Road 45
Newberry, Florida 32669
<http://www.timcoengr.com>
888.472.2424 F 352.472.2030 email: sid@timcoengr.com

2.1055 **Frequency stability:**
90.213(a)(1)

Temperature and voltage tests were performed to verify that the frequency remains within the .00025%, 2.5 ppm specification limit. The EUT was placed in the temperature chamber at 25° C and allowed to stabilize for one hour. The transmitter was keyed ON for one minute during which four frequency readings were recorded at 15-second intervals. The worse case number was taken for temperature plotting. The assigned channel frequency was considered to be the reference frequency. The temperature was then reduced to -30° C after which the transmitter was again allowed to stabilize for one hour. The transmitter was keyed ON for one minute, and again frequency readings were noted at 15-second intervals. The worst-case number was recorded for temperature plotting. This procedure was repeated in 10 degree increments up to + 50° C.

Readings were also taken at minus 15% of the battery voltage of 7.2 VDC, which we estimate to be the battery endpoint.

MEASUREMENT DATA:

Temperature (C)	Frequency Error (PPM)
60	-0.550
50	-0.370
40	-0.210
30	0.010
25	-0.035
20	-0.080
10	-0.240
0	-0.350
-10	-0.340
-20	-0.270
-30	-0.099

RESULTS OF MEASUREMENTS: The test results indicates that the EUT meets the requirements.

TIMCO ENGINEERING INC.

849 NW State Road 45
 Newberry, Florida 32669
<http://www.timcoengr.com>
 888.472.2424 F 352.472.2030 email: sid@timcoengr.com

2.1055(a)(1)
 90.214

Transient Frequency Behavior

REQUIREMENTS: Transmitters designed to operate in the 150-174 MHz and 421-512 MHz frequency bands must maintain transient frequencies within the maximum transient frequencies within the maximum frequency difference limits during the time intervals indicated:

Time Intervals	Maximum frequency difference	All Equipment	
		150-174 MHz	421-512 MHz

Transient Frequency Behavior for Equipment Designed to Operate on 25 kHz Channels

t_1^4	±25.0 kHz	5.0 mS	10.0 mS
t_2	±12.5 kHz	20.0 mS	25.0 mS
t_3^4	±25.0 kHz	5.0 mS	10.0 mS

Transient Frequency Behavior for Equipment Designed to Operate on 12.5 kHz Channels

t_1^4	±12.5 kHz	5.0 mS	10.0 mS
t_2	±6.25 kHz	20.0 mS	25.0 mS
t_3^4	±12.5 kHz	5.0 mS	10.0 mS

Transient Frequency Behavior for Equipment Designed to Operate on 6.25 kHz Channels

t_1^4	±6.25 kHz	5.0 mS	10.0 mS
t_2	±3.125 kHz	20.0 mS	25.0 mS
t_3^4	±6.25 kHz	5.0 mS	10.0 mS

TIMCO ENGINEERING INC.

849 NW State Road 45

Newberry, Florida 32669

<http://www.timcoengr.com>

888.472.2424 F 352.472.2030 email: sid@timcoengr.com

TEST PROCEEDURE: TIA/EIA TS603 PARA 2.2.19, the levels were set as follows;

1. Using the variable attenuator the transmitter level was set to 40 dB below the test receivers maximum input level, then the transmitter was turned off.
2. With the transmitter off the signal generator was set 20dB below the level of the transmitter in the above step, this level will be maintained with the signal generator through-out the test.
3. Reduce the attenuation between the transmitter and the RF detector by 30 dB.
4. With the levels set as above the transient frequency behavior was observed & recorded.

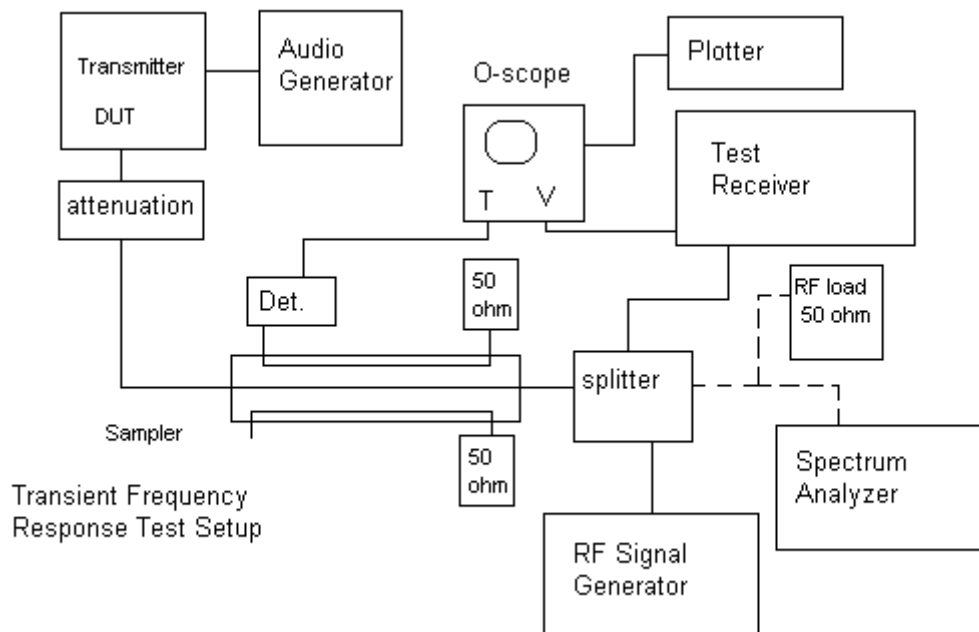

APPLICANT: RELM WIRELESS CORPORATION

FCC ID: ARURPU499A

REPORT #: R\RELM_ARU\191AUT4\191AUT4TestReport.doc

TIMCO ENGINEERING INC.

849 NW State Road 45

Newberry, Florida 32669

<http://www.timcoengr.com>

888.472.2424 F 352.472.2030 email: sid@timcoengr.com

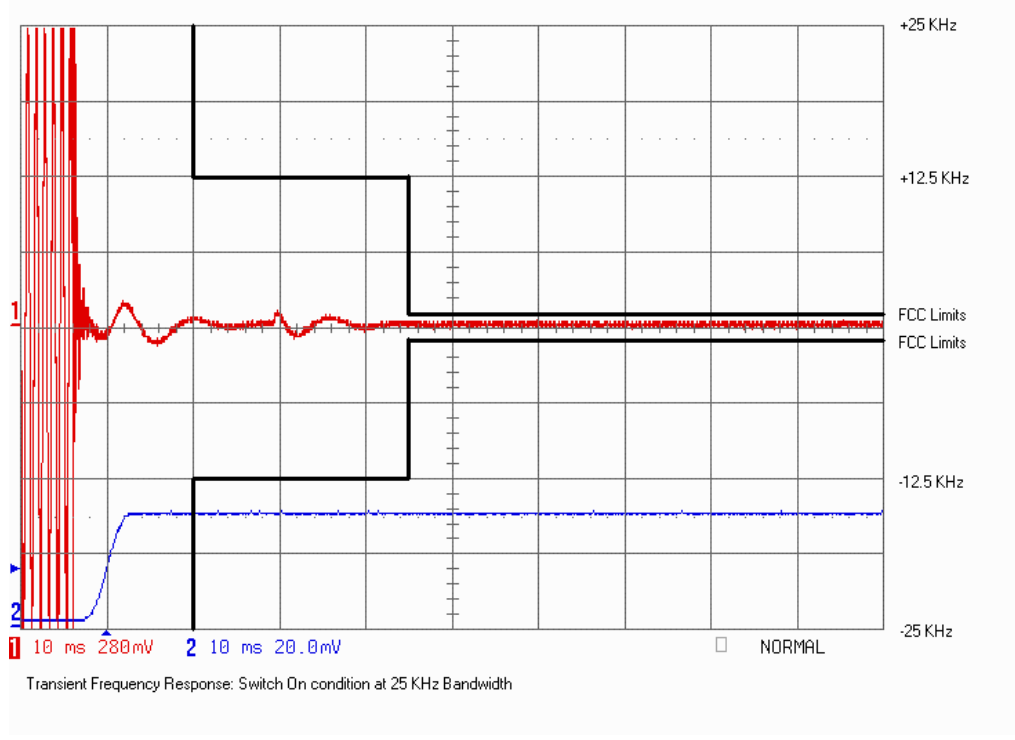

Wide Band Mode (25 kHz)

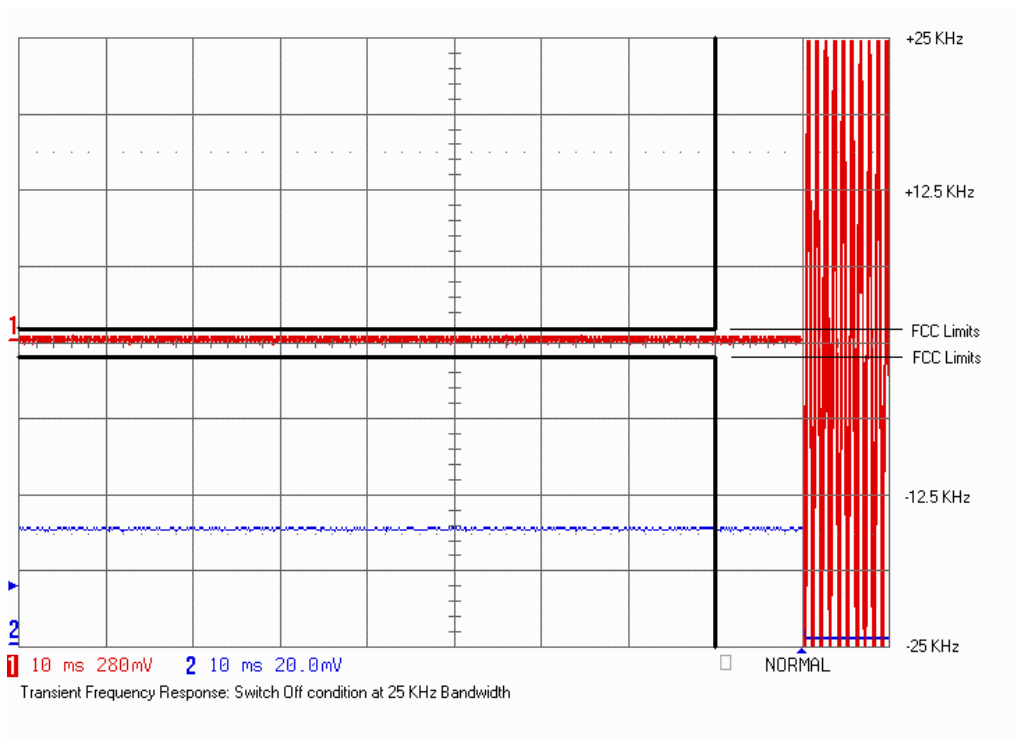

APPLICANT: RELM WIRELESS CORPORATION

FCC ID: ARURPU499A

REPORT #: R\RELM_ARU\191AUT4\191AUT4TestReport.doc

TIMCO ENGINEERING INC.

849 NW State Road 45

Newberry, Florida 32669

<http://www.timcoengr.com>

888.472.2424 F 352.472.2030 email: sid@timcoengr.com

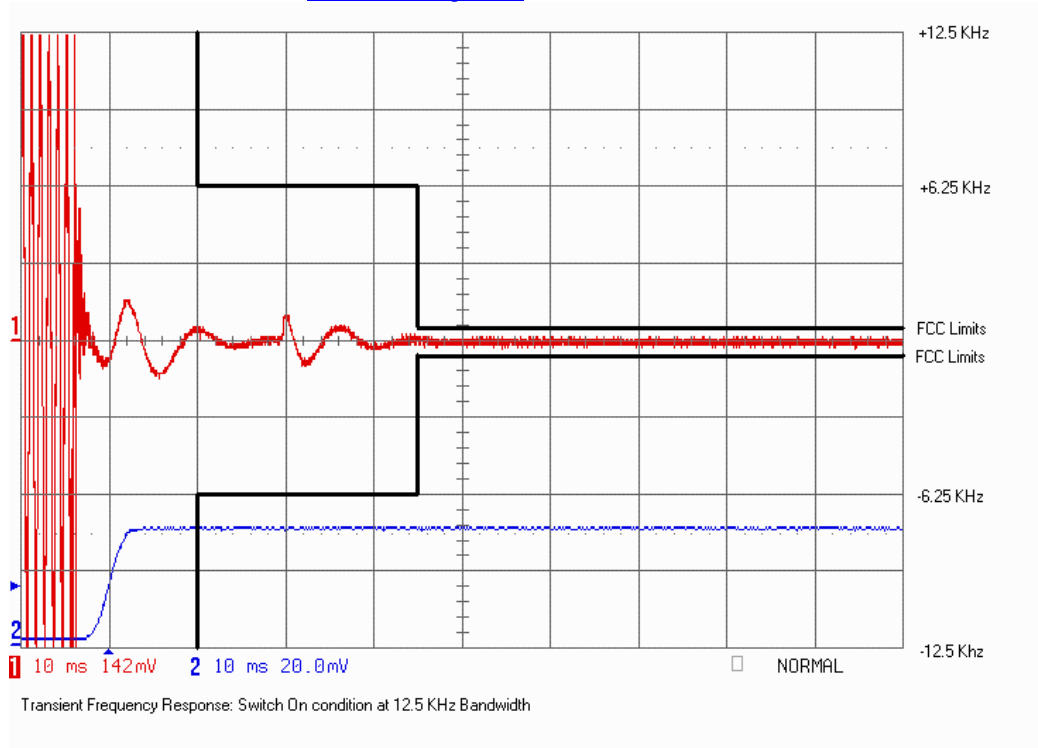

Narrow Band Mode (12.5 kHz)

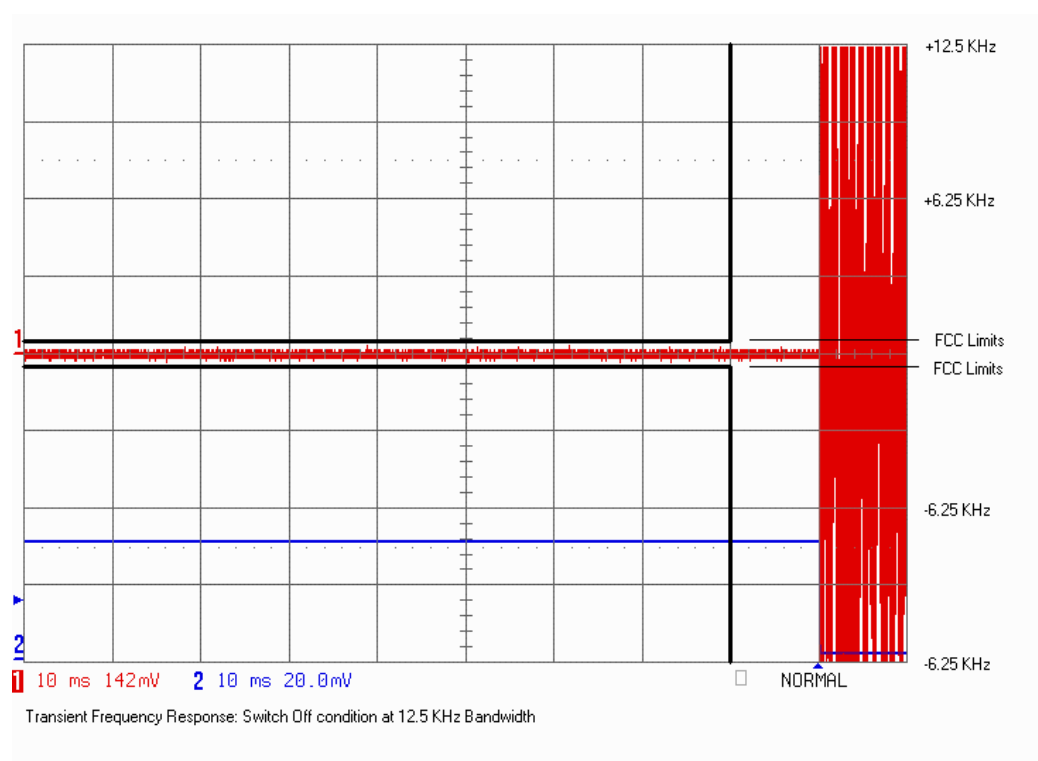

APPLICANT: RELM WIRELESS CORPORATION

FCC ID: ARURPU499A

REPORT #: R\RELM_ARU\191AUT4\191AUT4TestReport.doc

TIMCO ENGINEERING INC.

849 NW State Road 45
 Newberry, Florida 32669
<http://www.timcoengr.com>
 888.472.2424 F 352.472.2030 email: sid@timcoengr.com

EMC Equipment List

	DEVICE	MFGR	MODEL	SERNO	CAL/CHAR DATE	DUE DATE or STATUS
X	3-Meter OATS	TEI	N/A	N/A	Listed 1/13/03	1/13/06
	3/10-Meter OATS	TEI	N/A	N/A	Listed 3/26/01	3/26/04
	Receiver, Beige Tower Spectrum Analyzer	HP	8566B Opt 462	3138A07786 3144A20661	CAL 8/31/01	8/31/03
	RF Preselector	HP	85685A	3221A01400	CAL 8/31/01	8/31/03
	Quasi-Peak Adapter	HP	85650A	3303A01690	CAL 8/31/01	8/31/03
X	Receiver, Blue Tower Spectrum Analyzer	HP	8568B	2928A04729 2848A18049	CAL 4/15/03	4/15/05
X	RF Preselector	HP	85685A	2926A00983	CAL 4/15/03	4/15/05
X	Quasi-Peak Adapter	HP	85650A	2811A01279	CAL 4/15/03	4/15/05
	Receiver, Silver/Grey Tower Spectrum Analyzer	HP	8566B Opt 462	3552A22064 3638A08608	CAL 10/14/02	10/14/04
	RF Preselector	HP	85685A	2620A00294	CAL 10/14/02	10/14/04
	Quasi-Peak Adapter	HP	85650A	3303A01844	CAL 10/14/02	10/14/04
	Preamplifier	HP	8449B	3008A01075	CHAR 1/28/02	1/28/04
X	Biconnical Antenna	Electro-Metrics	BIA-25	1171	CAL 4/26/01	4/26/03
	Biconnical Antenna	Eaton	94455-1	1096	CAL 10/1/01	10/1/03
	Biconnical Antenna	Eaton	94455-1	1057	CAL 3/18/03	3/18/05
	BiconiLog Antenna	EMCO	3143	9409-1043		
X	Log-Periodic Antenna	Electro-Metrics	LPA-25	1122	CAL 10/2/01	10/2/03
	Log-Periodic Antenna	Electro-Metrics	EM-6950	632	CHAR 10/15/01	10/15/03

APPLICANT: RELM WIRELESS CORPORATION

FCC ID: ARURPU499A

REPORT #: R\RELM_ARU\191AUT4\191AUT4TestReport.doc

TIMCO ENGINEERING INC.

849 NW State Road 45
 Newberry, Florida 32669
 http://www.timcoengr.com
 888.472.2424 F 352.472.2030 email: sid@timcoengr.com

DEVICE	MFGR	MODEL	SERNO	CAL/CHAR DATE	DUE DATE or STATUS
Log-Periodic Antenna	Electro-Metrics	LPA-30	409	CAL 3/4/03	3/4/05
Dipole Antenna Kit	Electro-Metrics	TDA-30/1-4	152	CAL 3/21/01	3/21/04
Dipole Antenna Kit	Electro-Metrics	TDA-30/1-4	153	CAL 9/26/02	9/26/05
Double-Ridged Horn Antenna	Electro-Metrics	RGA-180	2319	CAL 2/17/03	2/17/05
Horn Antenna	Electro-Metrics	EM-6961	6246	CAL 3/31/03	3/31/05
Horn Antenna	ATM	19-443-6R	None	No Cal Required	
Passive Loop Antenna	EMC Test Systems	EMCO 6512	9706-1211	CHAR 7/10/01	7/10/03
Line Impedance Stabilization . . .	Electro-Metrics	ANS-25/2	2604	CAL 10/9/01	10/9/03
Line Impedance Stabilization . . .	Electro-Metrics	EM-7820	2682	CAL 3/12/03	3/12/05
Termaline Wattmeter	Bird Electronic Corporation	611	16405	CAL 5/25/99	5/25/01
Termaline Wattmeter	Bird Electronic Corporation	6104	1926	CHAR 12/12/01	12/12/03
Oscilloscope	Tektronix	2230	300572	CHAR 2/1/01	2/1/03
System One	Audio Precision	System One	SYS1-45868	CHAR 4/25/02	4/25/04
Temperature Chamber	Tenney Engineering	TTRC	11717-7	CHAR 1/22/02	1/22/04
AC Voltmeter	HP	400FL	2213A14499	CAL 10/9/01	10/9/03
AC Voltmeter	HP	400FL	2213A14261	CHAR 10/15/01	10/15/03
AC Voltmeter	HP	400FL	2213A14728	CHAR 10/15/01	10/15/03
X Digital Multimeter	Fluke	77	35053830	CHAR 1/8/02	1/8/04
Digital Multimeter	Fluke	77	43850817	CHAR 1/8/02	1/8/04
Digital Multimeter	HP	E2377A	2927J05849	CHAR 1/8/02	1/8/04
Multimeter	Fluke	FLUKE-77-3	79510405	CHAR 9/26/01	9/26/03

TIMCO ENGINEERING INC.

849 NW State Road 45

Newberry, Florida 32669

<http://www.timcoengr.com>

888.472.2424 F 352.472.2030 email: sid@timcoengr.com

	DEVICE	MFGR	MODEL	SERNO	CAL/CHAR DATE	DUE DATE or STATUS
	Peak Power Meter	HP	8900C	2131A00545	CHAR 1/26/01	1/26/03
	Power Meter	HP	432A	1141A07655	CAL 4/15/03	4/15/05
	Power Meter And Sensor	Bird	4421-107 4022	0166 0218	CAL 4/16/03	4/16/05
	Power Sensor	HP	478A	72129	CAL 4/15/03	4/15/05
	Digital Thermometer	Fluke	2166A	42032	CAL 1/16/02	1/16/04
	Thermometer	Traulsen	SK-128		CHAR 1/22/02	1/22/04
	Thermometer	Extech	4028	14871-2	CAL 3/7/03	3/7/05
X	Hygro-Thermometer	Extech	445703	0602	CAL 10/4/02	10/4/04
	Frequency Counter	HP	5352B	2632A00165	CAL 11/28/01	11/28/03
	Frequency Counter	HP	5385A	2730A03025	CAL 3/7/03	3/7/05
	Power Sensor	Agilent Technologies	84811A	2551A02705	CHAR 1/26/01	1/26/03
	Service Monitor	IFR	FM/AM 500A	5182	CAL 11/22/00	11/22/02
	Comm. Serv. Monitor	IFR	FM/AM 1200S	6593	CAL 5/12/02	5/12/04
	Signal Generator	HP	8640B	2308A21464	CAL 2/15/02	2/15/04
	Sweep Generator	Wiltron	6648	101009	CAL 4/15/03	4/15/05
	Sweep Generator	Wiltron	6669M	007005	CAL 3/3/03	3/3/05
	Modulation Analyzer	HP	8901A	3435A06868	CAL 9/5/01	9/5/03
	Modulation Meter	Boonton	8220	10901AB	CAL 4/15/03	4/15/05
	Near Field Probe	HP	HP11940A	2650A02748	CHAR 2/1/01	2/1/03
	BandReject Filter	Lorch Microwave	5BR4-2400/ 60-N	Z1	CHAR 3/2/01	3/2/03
	BandReject Filter	Lorch Microwave	6BR6-2442/ 300-N	Z1	CHAR 3/2/01	3/2/03
	BandReject Filter	Lorch Microwave	5BR4-10525/ 900-S	Z1	CHAR 3/2/01	3/2/03

APPLICANT: RELM WIRELESS CORPORATION

FCC ID: ARURPU499A

REPORT #: R\RELM_ARU\191AUT4\191AUT4TestReport.doc

TIMCO ENGINEERING INC.

849 NW State Road 45

Newberry, Florida 32669

<http://www.timcoengr.com>

888.472.2424 F 352.472.2030 email: sid@timcoengr.com

DEVICE	MFGR	MODEL	SERNO	CAL/CHAR DATE	DUE DATE or STATUS
High Pass Filter	Microlab	HA-10N		CHAR 10/4/01	10/4/03
High Pass Filter	Microlab	HA-20N		CHAR 2/7/03	2/7/05
Audio Oscillator	HP	653A	832-00260	CHAR 3/1/01	3/1/03
Frequency Counter	HP	5382A	1620A03535	CHAR 3/2/01	3/2/03
Frequency Counter	HP	5385A	3242A07460	CAL 3/7/03	3/7/05
Preamplifier	HP	8449B-H02	3008A00372	CHAR 3/4/01	3/4/03
Amplifier	HP	11975A	2738A01969	CHAR 3/1/01	3/1/03
Egg Timer	Unk			CHAR 8/31/01	8/31/03
Measuring Tape, 20M	Kraftixx	0631-20		CHAR 2/1/02	2/1/04
Measuring Tape, 7.5M	Kraftixx	7.5M PROFI		2/1/02	2/1/04
Coaxial Cable #51	Insulated Wire Inc.	NPS 2251- 2880	Timco #51	CHAR 1/23/02	1/23/04
Coaxial Cable #64	Semflex Inc.	60637	Timco #64	CHAR 1/24/02	1/24/04
Coaxial Cable #65	General Cable Co.	E9917 RG233/U	Timco #65	CHAR 1/23/02	1/23/04
Coaxial Cable #106	Unknown	Unknown	Timco #106	CHAR 1/23/02	1/23/04

APPLICANT: RELM WIRELESS CORPORATION

FCC ID: ARURPU499A

REPORT #: R\RELM_ARU\191AUT4\191AUT4TestReport.doc