

TIMCO ENGINEERING INC.

849 NW State Road 45

Newberry, Florida 32669

<http://www.timcoengr.com>

888.472.2424 F 352.472.2030 email: sid@timcoengr.com



Test Report

Product Name: UHF TRANSCEIVER
Frequency Range: 400 - 420 MHz

FCC ID: ARURPU416B

Applicant:

**RELM WIRELESS CORPORATION
7100 TECHNOLOGY DRIVE
W. MELBOURNE FLORIDA 32904**

Date Receipt: SEPTEMBER 28, 2004

Date Tested: OCTOBER 19, 2004

APPLICANT: RELM WIRELESS CORPORATION

FCC ID: ARURPU416B

REPORT #: R\RELM_ARU\1588AUT4\1588AUT4TestReport.doc

COVER PAGE

TIMCO ENGINEERING INC.

849 NW State Road 45
Newberry, Florida 32669
<http://www.timcoengr.com>
888.472.2424 F 352.472.2030 email: sid@timcoengr.com

APPLICANT: RELM WIRELESS CORPORATION

FCC ID: ARURPU416B

TABLE OF CONTENTS LIST

TEST REPORT:

PAGE 1.....	GENERAL INFORMATION & TECHNICAL DESCRIPTION
PAGE 2.....	TECHNICAL DESCRIPTION CONTINUED RF POWER OUTPUT
PAGE 3.....	MODULATION CHARACTERISTICS AUDIO FREQUENCY RESPONSE
PAGE 4.....	AUDIO LOW PASS FILTER
PAGE 5.....	MODULATION LIMITING PLOT
PAGE 6-7.....	OCCUPIED BANDWIDTH
PAGE 8-11.....	OCCUPIED BANDWIDTH PLOTS
PAGE 12.....	SPURIOUS EMISSIONS AT ANTENNA TERMINALS
PAGE 13.....	METHOD OF MEASURING SPURIOUS EMISSIONS AT ANTENNA TERMINALS
PAGE 14-15.....	FIELD STRENGTH OF SPURIOUS EMISSIONS
PAGE 16.....	METHOD OF MEASURING RADIATED SPURIOUS EMISSIONS
PAGE 17.....	FREQUENCY STABILITY
PAGE 18-19.....	TRANSIENT FREQUENCY BEHAVIOR
PAGE 20-23.....	TRANSIENT FREQUENCY RESPONSE PLOTS
PAGE 24-29.....	EQUIPMENT LIST

EXHIBITS CONTAINING:

BLOCK DIAGRAM
SCHEMATIC
PARTS LIST
USERS MANUAL
LABEL SAMPLE
LABEL LOCATION
EXTERNAL PHOTOGRAPHS
INTERNAL PHOTOGRAPHS
TUNING PROCEDURE
OPERATIONAL DESCRIPTION
TEST SET UP PHOTOGRAPH

APPLICANT: RELM WIRELESS CORPORATION

FCC ID: ARURPU416B

REPORT #: R\RELM_ARU\1588AUT4\1588AUT4TestReport.doc

TABLE OF CONTENTS

TIMCO ENGINEERING INC.

849 NW State Road 45
Newberry, Florida 32669
<http://www.timcoengr.com>
888.472.2424 F 352.472.2030 email: sid@timcoengr.com

GENERAL INFORMATION REQUIRED FOR CERTIFICATION OF A LICENSED TRANSMITTER

2.1033(c)(1)(2) RELM WIRELESS CORPORATION will manufacture the FCCID: ARURPU416B UHF TRANSCEIVER in quantity, for use under FCC RULES PART 90.

RELM WIRELESS CORPORATION
7100 TECHNOLOGY DRIVE
W. MELBOURNE, FLORIDA 32904

2.1033(c) **TECHNICAL DESCRIPTION**

2.1033(c)(3) Instruction book. A draft copy of the instruction manual is included.

2.1033(c)(4) Type of Emission: 10K8F3E
90.209
90.207 Bn = 2M + 2DK
M = 3000
D = 2400
Bn = 2(3000) + 2(2400) = 10.8k

2.1033(c)(5) Frequency Range: 400 - 420 MHz
90.209 (b)(5)

2.1033(c)(4) Type of Emission: 14K0F3E
90.209
90.207 Bn = 2M + 2DK
M = 3000
D = 4000
Bn = 2(3000) + 2(4000) = 14k

2.1033(c)(5) Frequency Range: 400 - 420 MHz
90.209 (b)(5)

2.1033(c)(6)(7) Power Output shall not exceed 59 Watts into a 50 ohm resistive load. There are no user power controls.
90.205

2.1033(c)(8) DC Voltages and Current into Final Amplifier:
POWER INPUT:

FINAL AMPLIFIER ONLY

INPUT POWER: (7.2V)(2.00A) = 14.40 Watts

2.1033(c)(9) Tune-up procedure. The tune-up procedure is included.

2.1033(c)(10) Complete Circuit Diagrams: The circuit diagram is included. The block diagram is included.

APPLICANT: RELM WIRELESS CORPORATION

FCC ID: ARURPU416B

REPORT #: R\RELM_ARU\1588AUT4\1588AUT4TestReport.doc

TIMCO ENGINEERING INC.

849 NW State Road 45
Newberry, Florida 32669
<http://www.timcoengr.com>
888.472.2424 F 352.472.2030 email: sid@timcoengr.com

- 2.1033(c)(11) Description of all circuitry and devices provided for determining and stabilizing frequency is included in the circuit description.
- 2.1033(c)(12) A photograph or drawing of the equipment identification label is included.
- 2.1033(c)(13) Photographs of the equipment of sufficient clarity to reveal equipment construction and layout and label location are included.
- 2.1033(c)(14) Digital Modulation is not allowed
- 2.1033(c)(15) The data required for 2.1046 through 2.1057 is submitted below.
- 2.1046(a) **RF POWER OUTPUT**
RF power is measured by connecting a 50-ohm, resistive wattmeter to the RF output connector. With a nominal battery voltage, and the transmitter properly adjusted the RF output measures:

OUTPUT POWER: 4.9 Watts

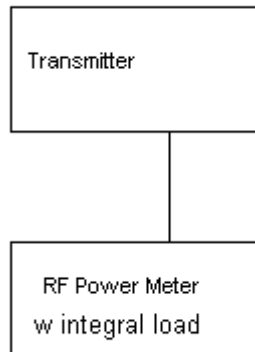

APPLICANT: RELM WIRELESS CORPORATION

FCC ID: ARURPU416B

REPORT #: R\RELM_ARU\1588AUT4\1588AUT4TestReport.doc

TIMCO ENGINEERING INC.

849 NW State Road 45
Newberry, Florida 32669
<http://www.timcoengr.com>
888.472.2424 F 352.472.2030 email: sid@timcoengr.com

2.1047(a)(b) Modulation characteristics:

AUDIO FREQUENCY RESPONSE

The audio frequency response was measured in accordance with TIA/EIA Specification 603. A curve or equivalent data showing the frequency response of the audio modulating circuit over a range of 100 - 5000Hz shall be submitted. The audio frequency response curve is shown below.

Audio Frequency Response

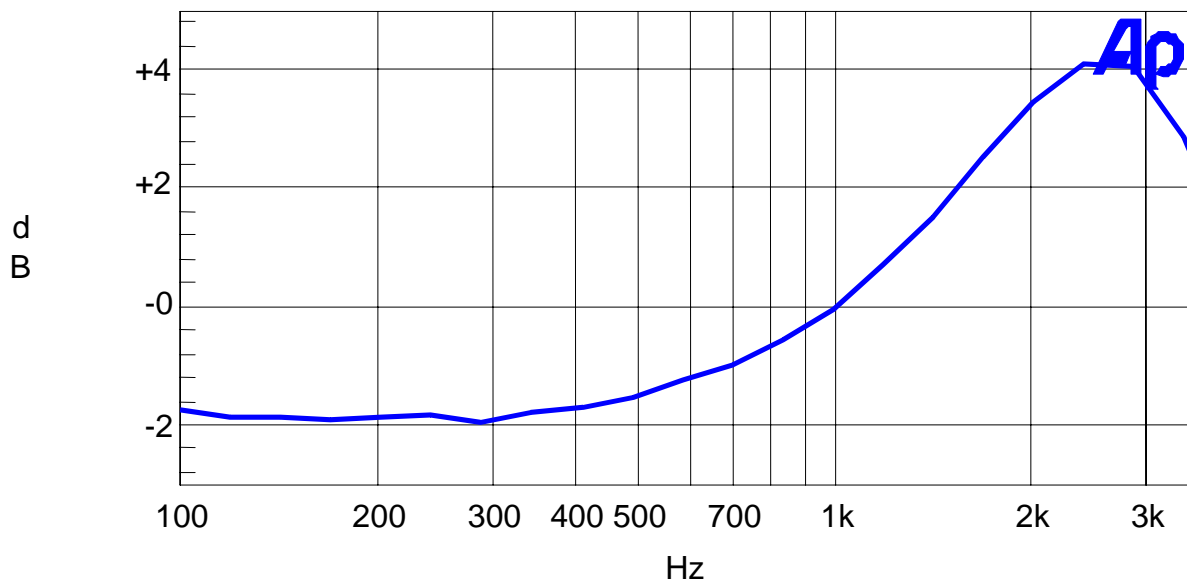

APPLICANT: RELM WIRELESS CORPORATION

FCC ID: ARURPU416B

REPORT #: R\RELM_ARU\1588AUT4\1588AUT4TestReport.doc

TIMCO ENGINEERING INC.

849 NW State Road 45
Newberry, Florida 32669
<http://www.timcoengr.com>
888.472.2424 F 352.472.2030 email: sid@timcoengr.com

2.1047(a)

Voice modulated communication equipment:

For equipment required to have an audio low-pass filter, a curve showing the frequency response of the filter, or of all the circuitry installed between the modulation limiter and the modulated stage shall be submitted.

Audio Low Pass Filter

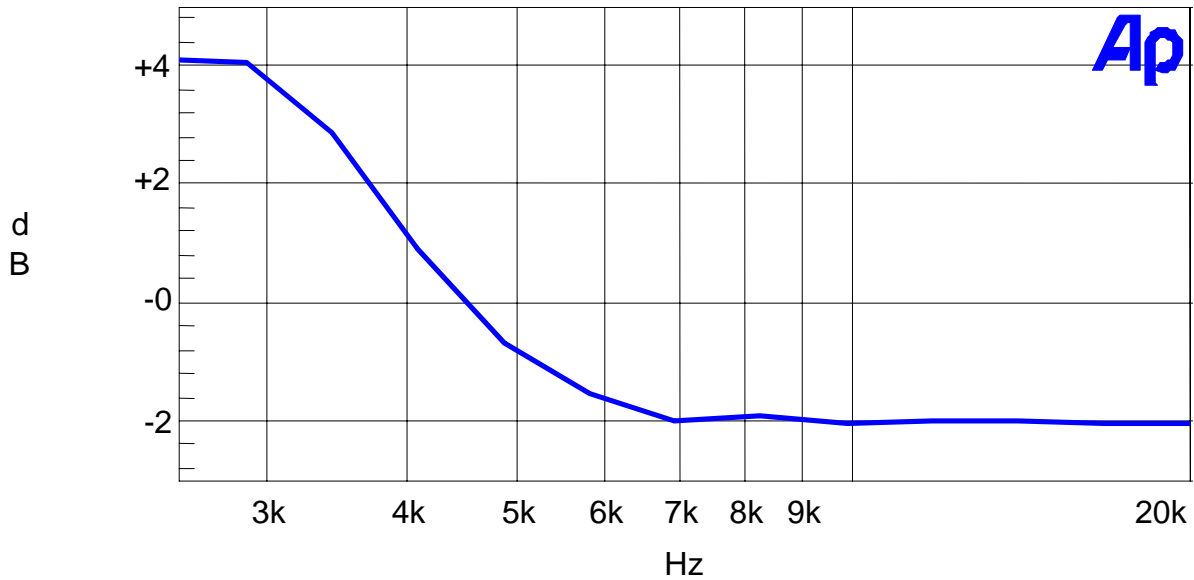

APPLICANT: RELM WIRELESS CORPORATION

FCC ID: ARURPU416B

REPORT #: R\RELM_ARU\1588AUT4\1588AUT4TestReport.doc

TIMCO ENGINEERING INC.

849 NW State Road 45
Newberry, Florida 32669
<http://www.timcoengr.com>
888.472.2424 F 352.472.2030 email: sid@timcoengr.com

2.1047(b)

Audio input versus modulation

The audio input level needed for a particular percentage of modulation was measured in accordance with TIA/EIA Specification 603. The audio input curves versus modulation are shown below. Curves are provided for audio input frequencies of 300, 1000, and 2500 Hz.

Modulation Limiting Plots:

2.5 KHz (Green), 1.0 KHz (Blue), and 300 Hz (Yellow)

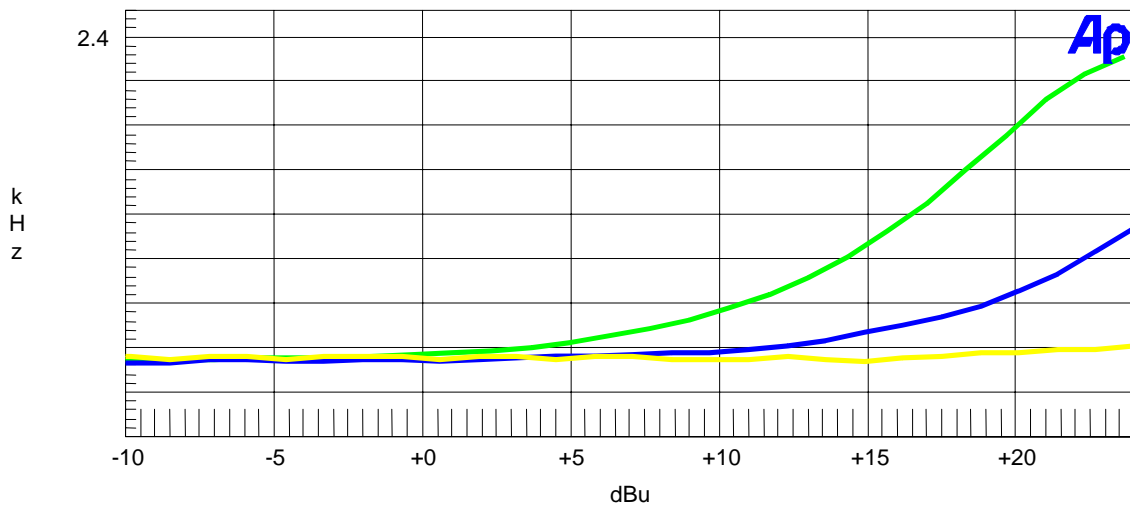

Modulation Limiting Plots:

2.5 KHz (Green), 1.0 KHz (Blue), and 300 Hz (Yellow)

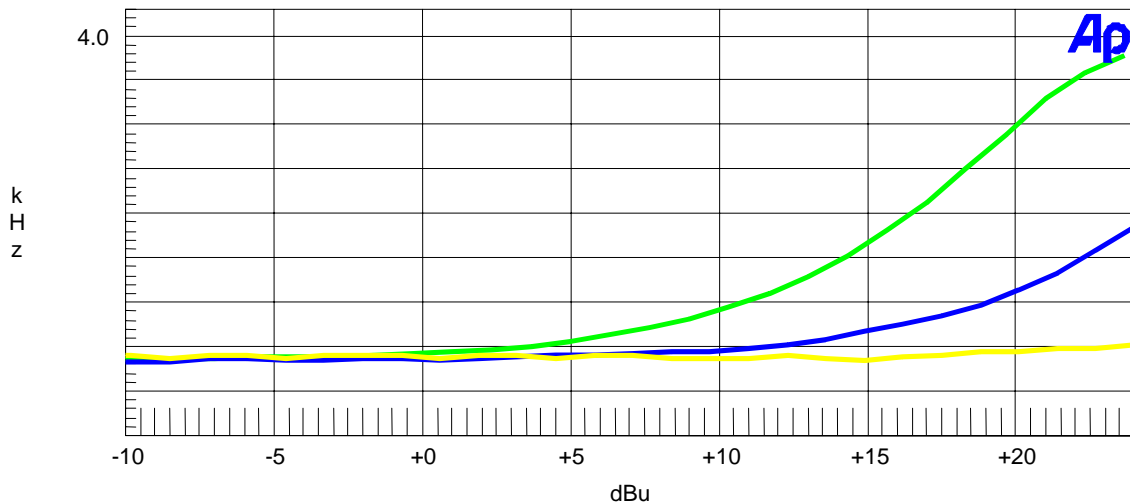

APPLICANT: RELM WIRELESS CORPORATION

FCC ID: ARURPU416B

REPORT #: R\RELM_ARU\1588AUT4\1588AUT4TestReport.doc

TIMCO ENGINEERING INC.

849 NW State Road 45
Newberry, Florida 32669
<http://www.timcoengr.com>
888.472.2424 F 352.472.2030 email: sid@timcoengr.com

2.1049 **Occupied bandwidth:**

2.1049(c) **EMISSION BANDWIDTH:**

90.210 (b) **25kHz Channel Spacing**

Data in the plots show that on any frequency removed from the assigned frequency by more than 50%, but not more than 100%: At least 25dB. On any frequency removed from the assigned frequency by more than 100%, but not more than 250%: At least 35 dB. On any frequency removed from the assigned frequency by more than 250%, of the authorized bandwidth: At least $43 + 10\log(P)$ dB.

90.210 (c) **12.5kHz Channel Spacing Not Equipped with a Low Pass Filter**

For transmitters that are not equipped with an audio low pass filter pursuant to S90.211 (b), the power of any emission must be attenuated below the un-modulated carrier output power as follows; (1) On any frequency removed from the center of the authorized bandwidth by a displacement frequency (f_d in kHz) of more than 5 kHz but not more than 10 kHz: At least $83 \log(f_d/5)$ dB; (2) ON any frequency removed from the center of the authorized bandwidth by a displacement frequency (f_d in kHz) of more than 10 kHz, but not more than 250% of the authorized bandwidth: At least $29 \log(f_d^2/11)$ dB or 50 dB, whichever is the lesser attenuation; (3) On any frequency removed from the center of the authorized bandwidth by more than 250% of the authorized bandwidth: At least $43+10 \log(P_o)$ dB.

90.210 (d) **Emission Mask D - 12.5 kHz channel BW equipment**

For transmitters designed to operate with a 12.5 kHz channel bandwidth, any emission must be attenuated below the power (P) of the highest emission contained within the authorized bandwidth as follows:

- (1) On any frequency from the center of the authorized bandwidth f_0 to 5.625 kHz removed from f_0 : Zero dB.
- (2) On any frequency from the center of the authorized bandwidth by a displacement frequency (f_d in kHz) of more than 5.625 kHz but no more than 12.5 kHz: At least $7.27 (f_d - 2.88 \text{ kHz})$ dB.
- (3) On any frequency removed from the center of the authorized bandwidth by a displacement frequency (f_d in kHz) of more than 12.5 kHz: At least $50 + 10\log(P)$ dB or 70 dB, whichever is the lesser attenuation.

APPLICANT: RELM WIRELESS CORPORATION

FCC ID: ARURPU416B

REPORT #: R\RELM_ARU\1588AUT4\1588AUT4TestReport.doc

TIMCO ENGINEERING INC.

849 NW State Road 45
Newberry, Florida 32669
<http://www.timcoengr.com>
888.472.2424 F 352.472.2030 email: sid@timcoengr.com

90.210 (e) Emission Mask E - 6.25 kHz channel BW equipment

For transmitters designed to operate with a 6.25 kHz bandwidth, any emission must be attenuated below the power (P) of the highest emission contained within the authorized bandwidth as follows:

- (1) On any frequency from the center of the authorized bandwidth f_0 to 3.0 kHz removed from f_0 : Zero dB.
- (2) On any frequency from the center of the authorized bandwidth by a displacement frequency (f_d in kHz) of more than 3.0 kHz but no more than 4.6 kHz: At least $30 + 16.67(f_d - 3.0 \text{ kHz})$ or $55 + 10 \text{ Log}(P)$ or 65, whichever is the lesser attenuation.
- (3) On any frequency removed from the center of the authorized bandwidth by more than 4.6 kHz: At least $55 + 10 \text{ log}(P)$ dB or 65 dB, whichever is the lesser attenuation.

Radiotelephone transmitter with modulation limiter:

Test procedure diagram

OCCUPIED BANDWIDTH MEASUREMENT

Occupied BW Test Equipment Setup

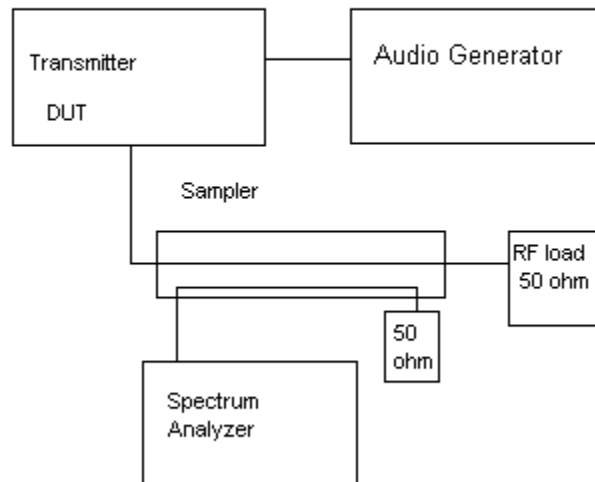

APPLICANT: RELM WIRELESS CORPORATION

FCC ID: ARURPU416B

REPORT #: R\RELM_ARU\1588AUT4\1588AUT4TestReport.doc

TIMCO ENGINEERING INC.

849 NW State Road 45

Newberry, Florida 32669

<http://www.timcoengr.com>

888.472.2424 F 352.472.2030 email: sid@timcoengr.com

OCCUPIED BANDWIDTH PLOTS

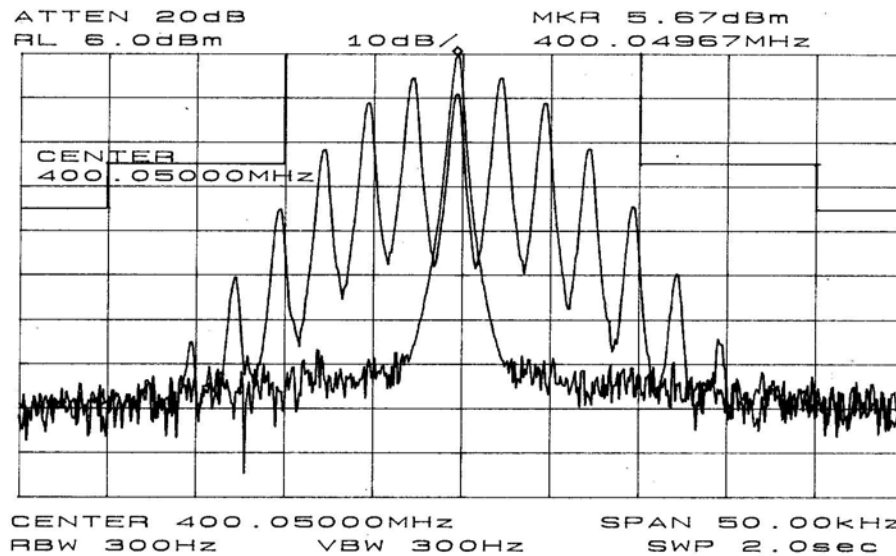

Occupied Bandwidth in Wide Band mode (25 KHz) at 400.050MHz

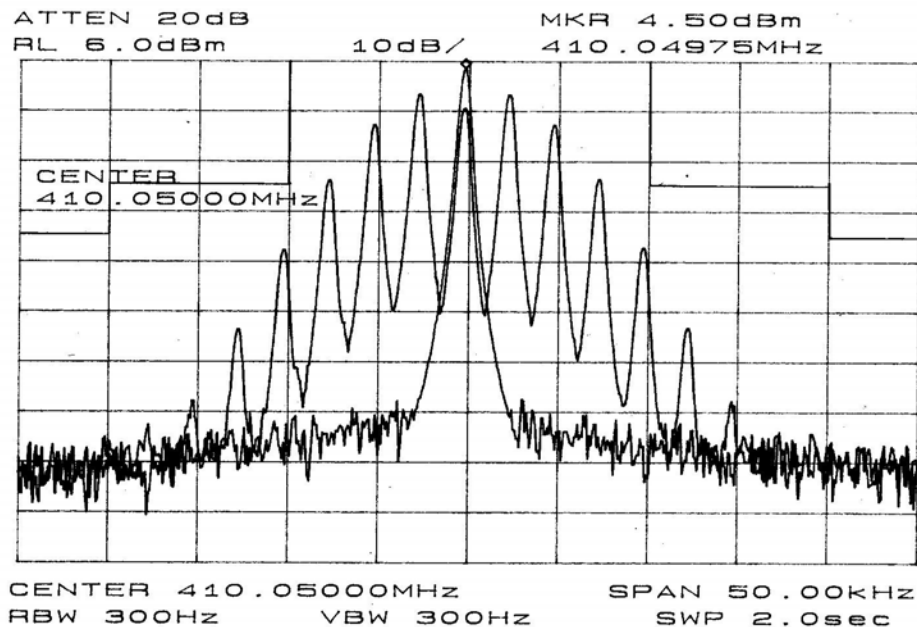

Occupied Bandwidth in Wide Band mode (25 KHz) at 410.050 MHz

APPLICANT: RELM WIRELESS CORPORATION

FCC ID: ARURPU416B

REPORT #: R\RELM_ARU\1588AUT4\1588AUT4TestReport.doc

TIMCO ENGINEERING INC.

849 NW State Road 45
Newberry, Florida 32669
<http://www.timcoengr.com>
888.472.2424 F 352.472.2030 email: sid@timcoengr.com

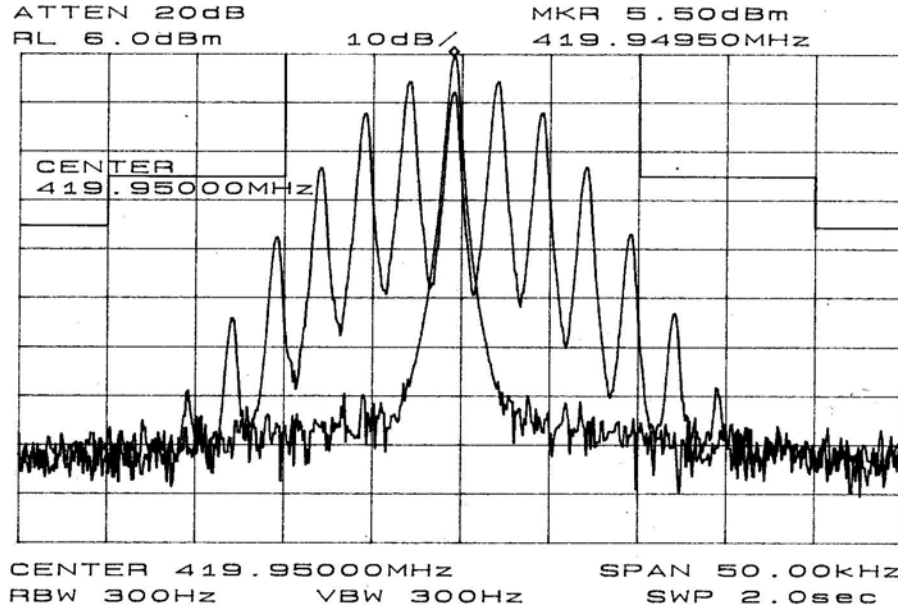

Occupied Bandwidth in Wide Band mode (25 KHz) at 419.950 MHz

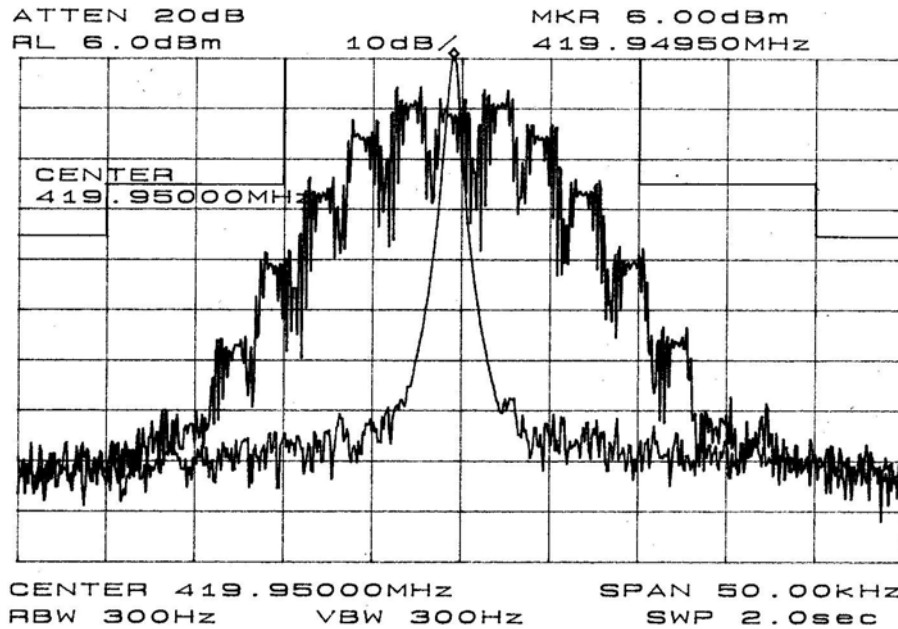

Occupied Bandwidth with DCS in Wide Band mode (25 KHz) at 419.950 MHz

APPLICANT: RELM WIRELESS CORPORATION

FCC ID: ARURPU416B

REPORT #: R\RELM_ARU\1588AUT4\1588AUT4TestReport.doc

TIMCO ENGINEERING INC.

849 NW State Road 45

Newberry, Florida 32669

<http://www.timcoengr.com>

888.472.2424 F 352.472.2030 email: sid@timcoengr.com

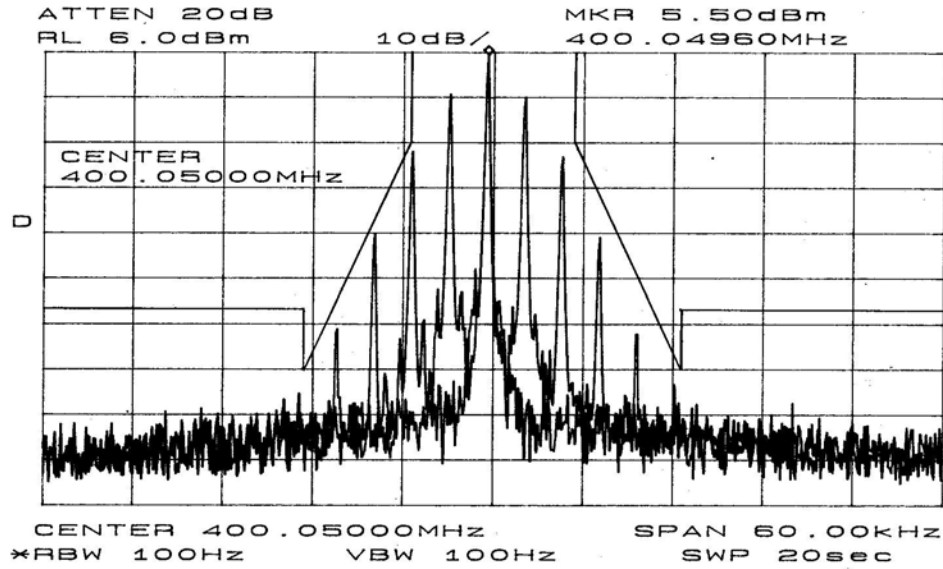

Occupied Bandwidth in Narrow Band mode (12.5 KHz) at 400.050 MHz

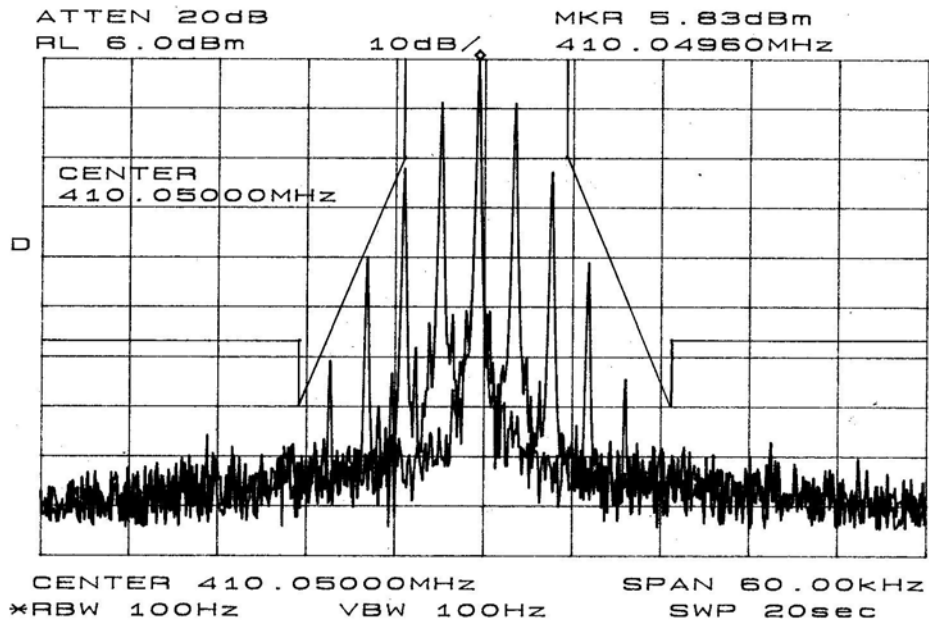

Occupied Bandwidth in Narrow Band mode (12.5 KHz) at 410.050 MHz

APPLICANT: RELM WIRELESS CORPORATION

FCC ID: ARURPU416B

REPORT #: R\RELM_ARU\1588AUT4\1588AUT4TestReport.doc

TIMCO ENGINEERING INC.

849 NW State Road 45

Newberry, Florida 32669

<http://www.timcoengr.com>

888.472.2424 F 352.472.2030 email: sid@timcoengr.com

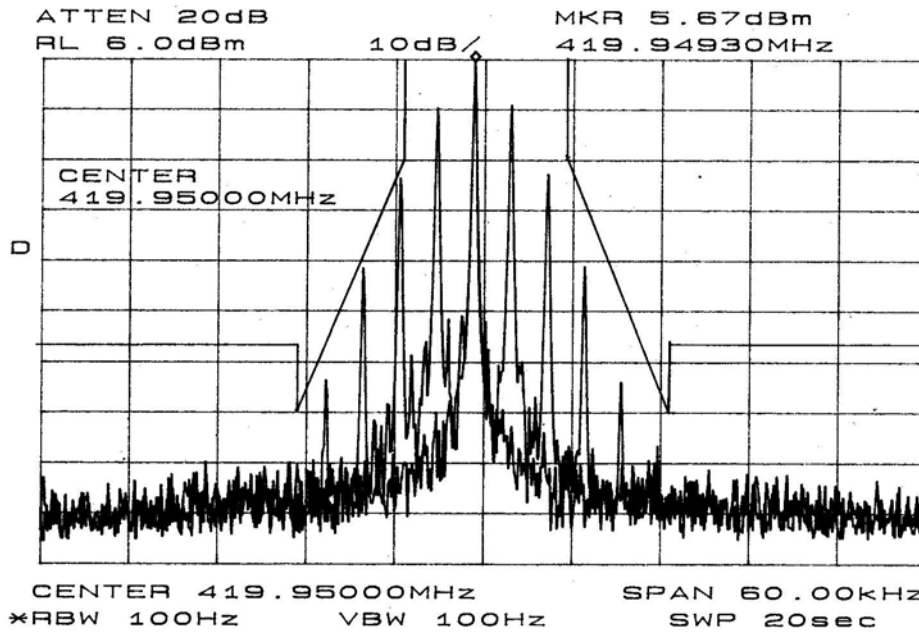

Occupied Bandwidth in Narrow Band mode (12.5 KHz) at 419.950 MHz

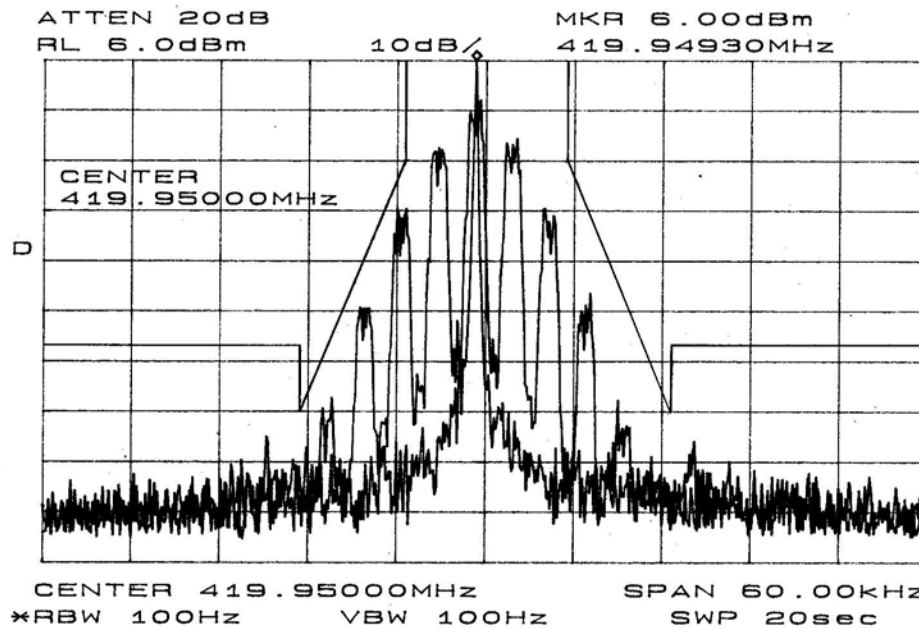

Occupied Bandwidth with DCS in Narrow Band mode (12.5 KHz) at 419.950 MHz

APPLICANT: RELM WIRELESS CORPORATION

FCC ID: ARURPU416B

REPORT #: R\RELM_ARU\1588AUT4\1588AUT4TestReport.doc

TIMCO ENGINEERING INC.

849 NW State Road 45

Newberry, Florida 32669

<http://www.timcoengr.com>

888.472.2424 F 352.472.2030 email: sid@timcoengr.com

2.1051(a) Spurious emissions at antenna terminals (conducted):

Data below shows the level of conducted spurious responses. The carrier was modulated 100% using a 2500 Hz tone. The spectrum was scanned from 0.4 to at least the 10th harmonic of the fundamental. The measurements were made in accordance with standard TIA/EIA-603.

FCC Limit: $50 + 10\log(4.9) = 57.00$ dB

TF	EF	dB below carrier
HIGH POWER		
400	400	0.0
	800	71.6
	1200	89.1
	1600	85.5
	2000	86.5
	2400	99.6
	2800	96.7
	3200	93.9
	3600	97.8
	4000	99.3
TF	EF	dB below carrier
LOW POWER		
410	410	0.0
	820	71.9
	1230	87.1
	1640	85.7
	2050	89.6
	2460	98.9
	2870	94.9
	3280	95.6
	3690	98.4
	4100	98.2
TF	EF	dB below carrier
LOW POWER		
419.9	419.9	0.0
	839.8	72.0
	1259.7	87.2
	1679.6	85.2
	2099.5	90.5
	2519.4	97.8
	2939.3	98.8
	3359.2	110.8
	3779.1	104.1
	4199.0	102.3

APPLICANT: RELM WIRELESS CORPORATION

FCC ID: ARURPU416B

REPORT #: R\RELM_ARU\1588AUT4\1588AUT4TestReport.doc

TIMCO ENGINEERING INC.

849 NW State Road 45

Newberry, Florida 32669

<http://www.timcoengr.com>

888.472.2424 F 352.472.2030 email: sid@timcoengr.com

Method of Measuring Conducted Spurious Emissions

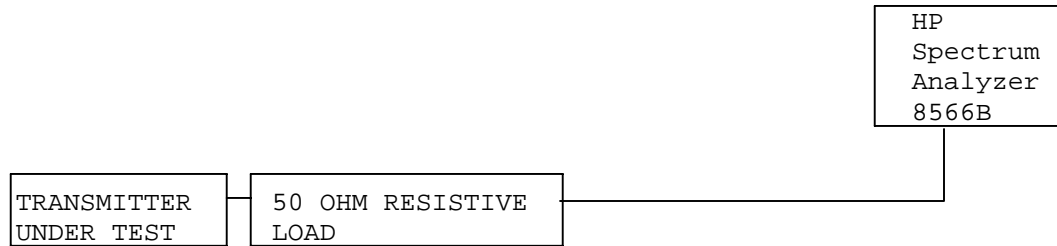

METHOD OF MEASUREMENT: The procedure used was TIA/EIA-603 STANDARD without any exceptions. The measurements were made at TIMCO ENGINEERING INC. 849 N.W. State Road 45, Newberry, Florida 32669.

APPLICANT: RELM WIRELESS CORPORATION

FCC ID: ARURPU416B

REPORT #: R\RELM_ARU\1588AUT4\1588AUT4TestReport.doc

TIMCO ENGINEERING INC.

849 NW State Road 45
Newberry, Florida 32669
<http://www.timcoengr.com>
888.472.2424 F 352.472.2030 email: sid@timcoengr.com

2.1053 Field strength of spurious emissions:

NAME OF TEST: RADIATED SPURIOUS EMISSIONS (400 & 410 MHz)

REQUIREMENTS: The FCC Limits for radiated emissions are the same as previously stated for the conducted emissions.

TEST DATA (400 MHz):

Emission Frequency MHz	Ant. Polarity	Corrected EUT Signal Reading	Coax Loss (dB)	Substitution Antenna (dBd)	dB Below Carrier (dBc)
400.00	0	36.58	0	-0.35	0
800.00	V	-24.70	0	-1.35	62.282
1200.00	V	-54.70	1.04	3.75	88.222
1600.00	H	-49.60	1.12	5.01	81.942
2000.00	V	-34.50	1.2	5.25	66.682
2400.00	H	-42.40	1.28	6.53	73.382
2800.00	H	-53.40	1.33	7.09	83.872
3200.00	H	-47.00	1.37	7.37	77.232
3600.00	V	-44.30	1.41	7.55	74.392
4000.00	V	-46.40	1.45	7.85	76.232

TEST DATA (410 MHz):

Emission Frequency MHz	Ant. Polarity	Corrected EUT Signal Reading	Coax Loss (dB)	Substitution Antenna (dBd)	dB Below Carrier (dBc)
410.00	0	36.62	0	-0.39	0
820.00	V	-25.70	0	-1.19	63.122
1230.00	H	-50.00	1.05	3.87	83.412
1640.00	V	-50.00	1.13	5.03	82.332
2050.00	H	-39.60	1.21	5.41	71.632
2460.00	H	-47.50	1.29	6.72	78.302
2870.00	H	-49.20	1.34	7.15	79.622
3280.00	H	-40.20	1.38	7.42	70.392
3690.00	H	-46.20	1.42	7.55	76.302
4100.00	H	-43.80	1.46	7.71	73.782

APPLICANT: RELM WIRELESS CORPORATION

FCC ID: ARURPU416B

REPORT #: R\RELM_ARU\1588AUT4\1588AUT4TestReport.doc

TIMCO ENGINEERING INC.

849 NW State Road 45
Newberry, Florida 32669
<http://www.timcoengr.com>
888.472.2424 F 352.472.2030 email: sid@timcoengr.com

2.1053 Field strength of spurious emissions:

NAME OF TEST: RADIATED SPURIOUS EMISSIONS (419.9 MHz)

REQUIREMENTS: The FCC Limits for radiated emissions are the same as previously stated for the conducted emissions.

TEST DATA:

Emission Frequency MHz	Ant. Polarity	Corrected EUT Signal Reading	Coax Loss (dB)	Substitution Antenna (dBd)	dB Below Carrier (dBc)
419.90	0	36.66	0	-0.43	0
839.80	V	-26.10	0	-1.03	63.362
1259.70	H	-50.40	1.05	3.99	83.692
1679.60	H	-49.20	1.14	5.06	81.512
2099.50	H	-42.50	1.22	5.57	74.382
2519.40	H	-44.80	1.3	6.87	75.462
2939.30	H	-49.00	1.34	7.2	79.372
3359.20	V	-44.90	1.39	7.47	75.052
3779.10	H	-46.70	1.43	7.55	76.812
4199.00	H	-48.60	1.47	7.87	78.432

APPLICANT: RELM WIRELESS CORPORATION

FCC ID: ARURPU416B

REPORT #: R\RELM_ARU\1588AUT4\1588AUT4TestReport.doc

TIMCO ENGINEERING INC.

849 NW State Road 45

Newberry, Florida 32669

<http://www.timcoengr.com>

888.472.2424 F 352.472.2030 email: sid@timcoengr.com

Method of Measuring Radiated Spurious Emissions

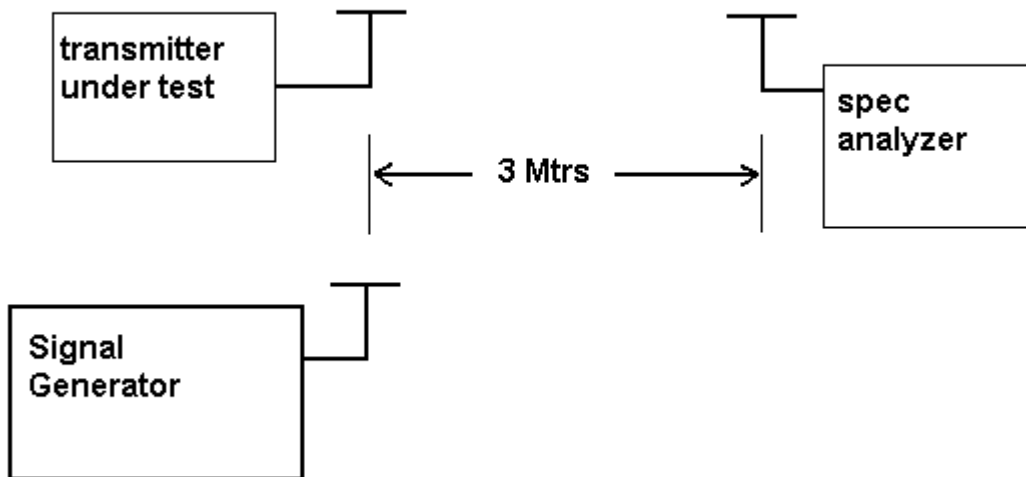

METHOD OF MEASUREMENTS: The tabulated data shows the results of the radiated field strength emissions test. The spectrum was scanned from 30 MHz to at least the tenth harmonic of the fundamental. This test was conducted per TIA/EIA STANDARD 603 using the substitution method. Measurements were made at the open field test site of TIMCO ENGINEERING, INC. located at 849 NW State Road 45, Newberry, FL 32669.

APPLICANT: RELM WIRELESS CORPORATION

FCC ID: ARURPU416B

REPORT #: R\RELM_ARU\1588AUT4\1588AUT4TestReport.doc

TIMCO ENGINEERING INC.

849 NW State Road 45
Newberry, Florida 32669
<http://www.timcoengr.com>
888.472.2424 F 352.472.2030 email: sid@timcoengr.com

2.1055 Frequency stability:
90.213(a)(1)
90.266(b)(3)

Frequency Stability Requirement: 1.5 ppm

Temperature range requirements: -30 to +50° C.

Voltage Variation +,- 15%.

Measurement procedure per TIA/EIA 603.

MEASUREMENT DATA:

Assigned Frequency (Ref. Frequency): 410.050 033 MHz

<u>TEMPERATURE °C</u>	<u>FREQUENCY MHz</u>	<u>PPM</u>
REFERENCE	410.050 033	00.0
-30	410.050 186	+ 0.37
-20	410.050 211	+ 0.43
-10	410.050 071	+ 0.09
0	410.049 983	- 0.12
+10	410.049 985	- 0.12
+20	410.050 065	+ 0.08
+30	410.050 127	+ 0.23
+40	410.050 169	+ 0.33
+50	410.050 233	+ 0.46

<u>%BATT.</u>	<u>DATA</u>	<u>PPM</u>
-15%	410.050 066	+ 0.08

RESULTS OF MEASUREMENTS: The test results indicates that the EUT meets the requirements.

APPLICANT: RELM WIRELESS CORPORATION

FCC ID: ARURPU416B

REPORT #: R\RELM_ARU\1588AUT4\1588AUT4TestReport.doc

TIMCO ENGINEERING INC.

849 NW State Road 45
 Newberry, Florida 32669
<http://www.timcoengr.com>
 888.472.2424 F 352.472.2030 email: sid@timcoengr.com

2.1055(a)(1)
 90.214

Transient Frequency Behavior

REQUIREMENTS: Transmitters designed to operate in the 150-174 MHz and 421-512 MHz frequency bands must maintain transient frequencies within the maximum transient frequencies within the maximum frequency difference limits during the time intervals indicated:

Time Intervals	Maximum frequency difference	All Equipment	
		150-174 MHz	421-512 MHz

Transient Frequency Behavior for Equipment Designed to Operate on 25 kHz Channels

t_1^4	±25.0 kHz	5.0 mS	10.0 mS
t_2	±12.5 kHz	20.0 mS	25.0 mS
t_3^4	±25.0 kHz	5.0 mS	10.0 mS

Transient Frequency Behavior for Equipment Designed to Operate on 12.5 kHz Channels

t_1^4	±12.5 kHz	5.0 mS	10.0 mS
t_2	±6.25 kHz	20.0 mS	25.0 mS
t_3^4	±12.5 kHz	5.0 mS	10.0 mS

Transient Frequency Behavior for Equipment Designed to Operate on 6.25 kHz Channels

t_1^4	±6.25 kHz	5.0 mS	10.0 mS
t_2	±3.125 kHz	20.0 mS	25.0 mS
t_3^4	±6.25 kHz	5.0 mS	10.0 mS

TIMCO ENGINEERING INC.

849 NW State Road 45

Newberry, Florida 32669

<http://www.timcoengr.com>

888.472.2424 F 352.472.2030 email: sid@timcoengr.com

TEST PROCEEDURE: TIA/EIA TS603 PARA 2.2.19, the levels were set as follows;

1. Using the variable attenuator the transmitter level was set to 40 dB below the test receivers maximum input level, then the transmitter was turned off.
2. With the transmitter off the signal generator was set 20dB below the level of the transmitter in the above step, this level will be maintained with the signal generator through-out the test.
3. Reduce the attenuation between the transmitter and the RF detector by 30 dB.
4. With the levels set as above the transient frequency behavior was observed & recorded.

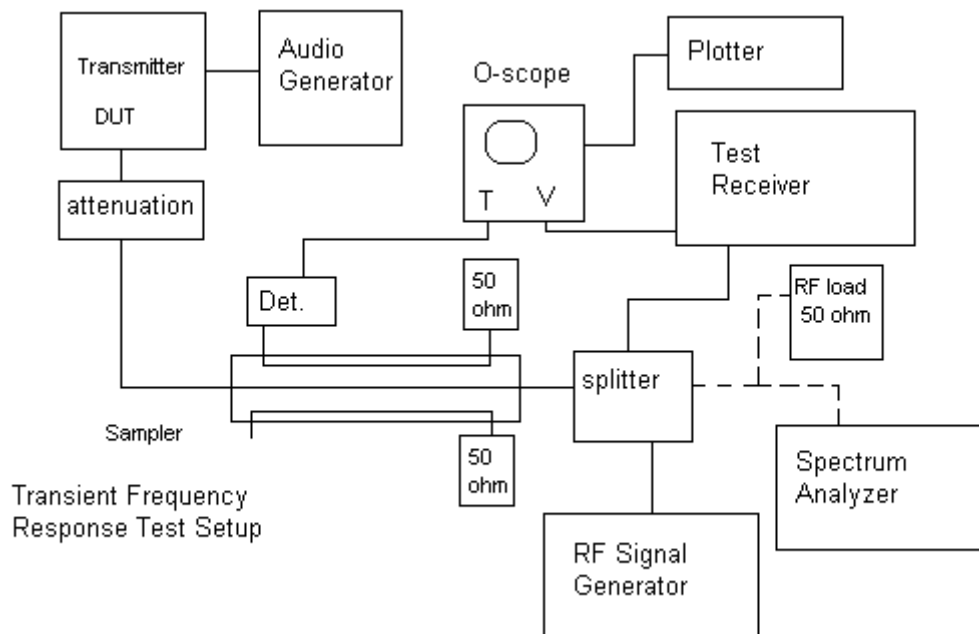

APPLICANT: RELM WIRELESS CORPORATION

FCC ID: ARURPU416B

REPORT #: R\RELM_ARU\1588AUT4\1588AUT4TestReport.doc

TIMCO ENGINEERING INC.

849 NW State Road 45
Newberry, Florida 32669
<http://www.timcoengr.com>
888.472.2424 F 352.472.2030 email: sid@timcoengr.com

TRANSIENT FREQUENCY RESPONSE PLOTS

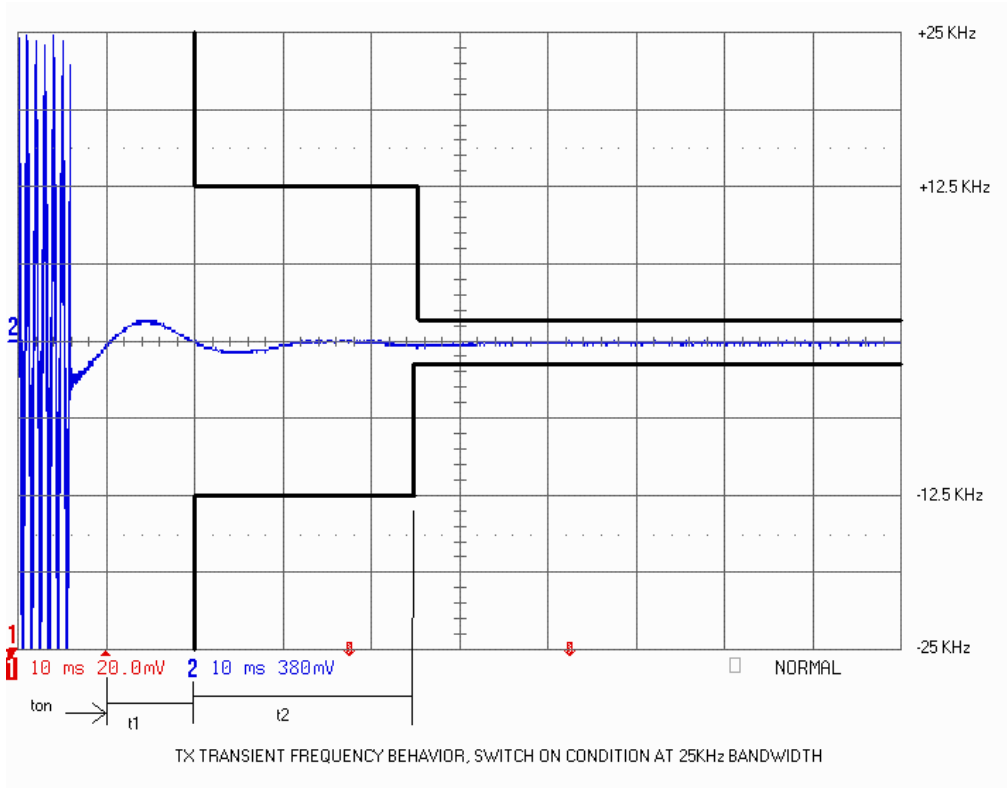

Transient Frequency Behavior Condition in Wide Band Mode (25 kHz)

APPLICANT: RELM WIRELESS CORPORATION

FCC ID: ARURPU416B

REPORT #: R\RELM_ARU\1588AUT4\1588AUT4TestReport.doc

TIMCO ENGINEERING INC.

849 NW State Road 45

Newberry, Florida 32669

<http://www.timcoengr.com>

888.472.2424 F 352.472.2030 email: sid@timcoengr.com

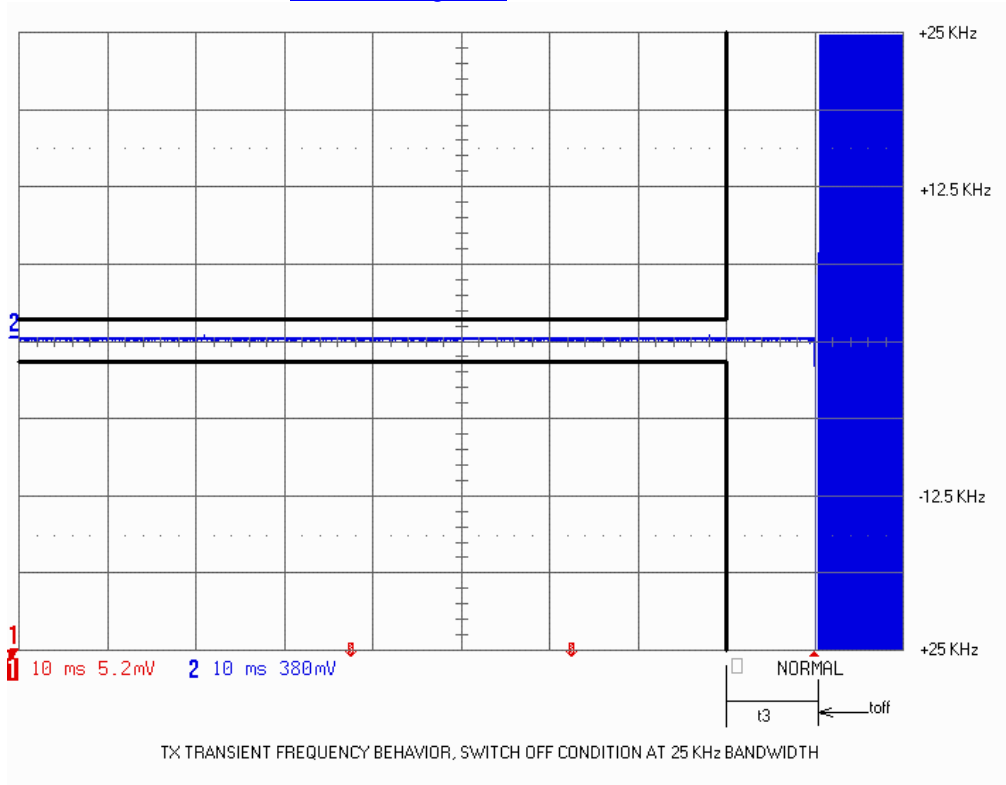

Transient Frequency Behavior Condition in Wide Band Mode (25 kHz)

APPLICANT: RELM WIRELESS CORPORATION

FCC ID: ARURPU416B

REPORT #: R\RELM_ARU\1588AUT4\1588AUT4TestReport.doc

TIMCO ENGINEERING INC.

849 NW State Road 45

Newberry, Florida 32669

<http://www.timcoengr.com>

888.472.2424 F 352.472.2030 email: sid@timcoengr.com

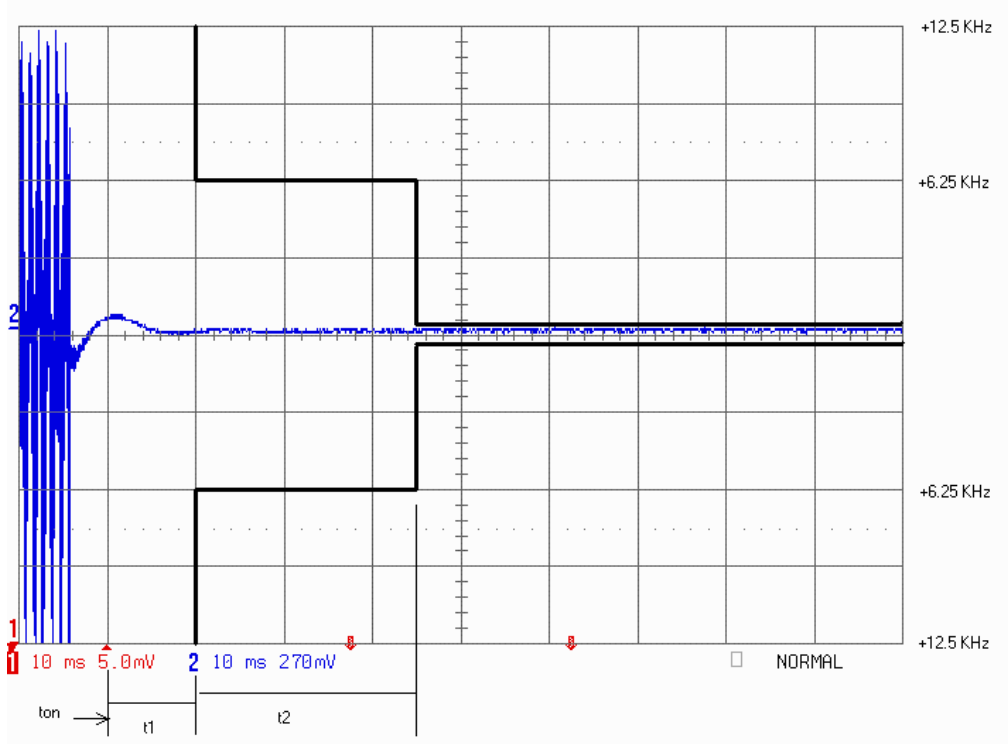

Transient Frequency Behavior Condition in Narrow Band Mode (12.5 kHz)

APPLICANT: RELM WIRELESS CORPORATION

FCC ID: ARURPU416B

REPORT #: R\RELM_ARU\1588AUT4\1588AUT4TestReport.doc

TIMCO ENGINEERING INC.

849 NW State Road 45

Newberry, Florida 32669

<http://www.timcoengr.com>

888.472.2424 F 352.472.2030 email: sid@timcoengr.com

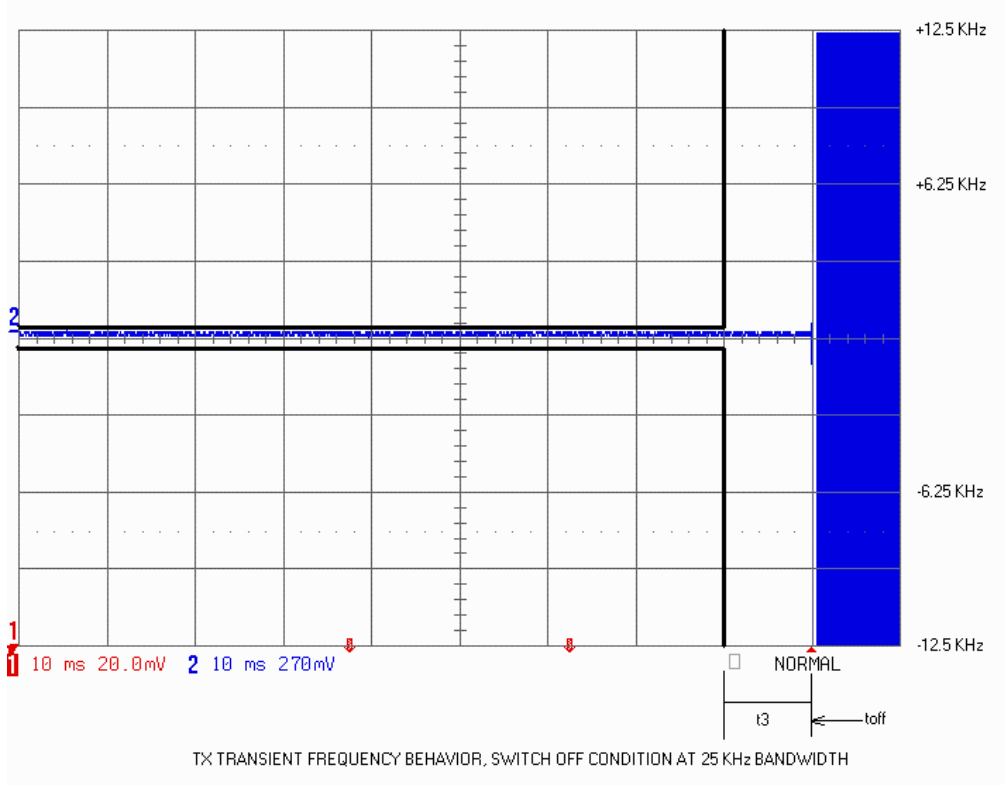

Transient Frequency Behavior Condition in Narrow Band Mode (12.5 kHz)

APPLICANT: RELM WIRELESS CORPORATION

FCC ID: ARURPU416B

REPORT #: R\RELM_ARU\1588AUT4\1588AUT4TestReport.doc

TIMCO ENGINEERING INC.

849 NW State Road 45
 Newberry, Florida 32669
<http://www.timcoengr.com>
 888.472.2424 F 352.472.2030 email: sid@timcoengr.com

EMC Equipment List

Device	Manufacturer	Model	Serial Number	Cal/Char Date	Due Date or Status
3-Meter OATS	TEI	N/A	N/A	Listed 1/13/03	1/12/06
3/10-Meter OATS	TEI	N/A	N/A	Listed 3/27/04	3/26/07
Tan Tower Spectrum Analyzer	HP	8566B Opt 462	3138A07786 3144A20661	CAL 9/23/03	9/23/05
Tan Tower RF Preselector	HP	85685A	3221A01400	CAL 9/23/03	9/23/05
Tan Tower Quasi-Peak Adapter	HP	85650A	3303A01690	CAL 9/23/03	9/23/05
Tan Tower Preamplifier	HP	8449B-H02	3008A00372	CAL 9/23/03	9/23/05
Blue Tower Spectrum Analyzer	HP	8568B	2928A04729 2848A18049	CAL 4/15/03	4/15/05
Blue Tower RF Preselector	HP	85685A	2620A00294	CAL 4/27/04	4/27/06
Blue Tower Quasi-Peak Adapter	HP	85650A	2811A01279	CAL 4/15/03	4/15/05
Silver Tower Spectrum Analyzer	HP	8566B Opt 462	3552A22064 3638A08608	CAL 3/22/04	3/22/06
Silver Tower RF Preselector	HP	85685A	2926A00983	CAL 3/22/04	3/22/06
Silver Tower Quasi-Peak Adapter	HP	85650A	3303A01844	CAL 3/22/04	3/22/06
Silver Tower Preamplifier	HP	8449B	3008A01075	CAL 3/22/04	3/22/06
Biconnical Antenna	Electro-Metrics	BIA-25	1171	CAL 4/26/01	4/26/03
Biconnical Antenna	Eaton	94455-1	1096	CAL 8/17/04	8/17/06
Biconnical Antenna	Eaton	94455-1	1057	CAL 3/18/03	3/18/05
BiconiLog Antenna	EMCO	3143	9409-1043	No Cal Required	
Log-Periodic Antenna	Electro-Metrics	LPA-25	1122	CAL 8/26/04	8/26/06
Log-Periodic Antenna	Electro-Metrics	LPA-30	409	CAL 3/4/03	3/4/05
Log-Periodic	Eaton	96005	1243	CAL	5/8/05

APPLICANT: RELM WIRELESS CORPORATION

FCC ID: ARURPU416B

REPORT #: R\RELM_ARU\1588AUT4\1588AUT4TestReport.doc

TIMCO ENGINEERING INC.

849 NW State Road 45

Newberry, Florida 32669

<http://www.timcoengr.com>

888.472.2424 F 352.472.2030 email: sid@timcoengr.com

Device	Manufacturer	Model	Serial Number	Cal/Char Date	Due Date or Status
Antenna				5/8/03	
Dipole Antenna Kit	Electro-Metrics	TDA-30/1-4	152	CAL 3/21/01	3/21/04
Dipole Antenna Kit	Electro-Metrics	TDA-30/1-4	153	CAL 9/26/02	9/26/05
Double-Ridged Horn Antenna	Electro-Metrics	RGA-180	2319	CAL 2/17/03	2/17/05
Horn Antenna *(at 3 meters)	Electro-Metrics	EM-6961	6246	CAL 3/31/03	3/31/05
Horn Antenna *(at 10 meters)	Electro-Metrics	EM-6961	6246	CAL 6/4/03	6/4/05
Passive Loop Antenna	EMC Test Systems	EMCO 6512	9706-1211	CHAR 7/10/01	7/10/03
Harmonic Mixer with Horn Antenna	Oleson Microwave Labs	M08HW/A	F30425-1	CHAR 4/25/03	4/25/05
Harmonic Mixer with Horn Antenna	Oleson Microwave Labs	M12HW/A	E30425-1	CHAR 4/25/03	4/25/05
LISN	Electro-Metrics	ANS-25/2	2604	CAL 8/27/04	8/27/06
LISN	Electro-Metrics	EM-7820	2682	CAL 3/12/03	3/12/05
Termaline Wattmeter	Bird Electronic Corporation	611	16405	CAL 7/16/04	7/16/06
Termaline Wattmeter	Bird Electronic Corporation	6104	1926	CAL 7/16/04	7/16/06
Oscilloscope	Tektronix	2230	300572	CAL 7/3/03	7/3/05
System One	Audio Precision	System One	SYS1-45868	CHAR 4/25/02	4/25/04
Temperature Chamber	Tenney Engineering	TTRC	11717-7	CHAR 1/22/02	1/22/04
AC Voltmeter	HP	400FL	2213A14499	CAL 7/19/04	7/19/06
AC Voltmeter	HP	400FL	2213A14261	CHAR 10/15/01	10/15/03
AC Voltmeter	HP	400FL	2213A14728	CHAR 10/15/01	10/15/03
Digital Multimeter	Fluke	77	35053830	CHAR 1/8/02	1/8/04
Digital Multimeter	Fluke	77	43850817	CHAR 1/8/02	1/8/04

APPLICANT: RELM WIRELESS CORPORATION

FCC ID: ARURPU416B

REPORT #: R\RELM_ARU\1588AUT4\1588AUT4TestReport.doc

TIMCO ENGINEERING INC.

849 NW State Road 45
 Newberry, Florida 32669
<http://www.timcoengr.com>
 888.472.2424 F 352.472.2030 email: sid@timcoengr.com

Device	Manufacturer	Model	Serial Number	Cal/Char Date	Due Date or Status
Digital Multimeter	HP	E2377A	2927J05849	CHAR 1/8/02	1/8/04
Multimeter	Fluke	FLUKE-77-3	79510405	CHAR 9/26/01	9/26/03
Peak Power Meter	HP	8900C	2131A00545	CAL 7/2/03	7/2/05
Power Sensor	Agilent Technologies	84811A	2551A02705	CAL 7/2/03	7/2/05
Power Meter	HP	432A	1141A07655	CAL 4/15/03	4/15/05
Power Sensor	HP	478A	72129	CAL 4/15/03	4/15/05
Power Meter And Sensor	Bird	4421-107 & 4022	0166 & 0218	CAL 4/16/03	4/16/05
Digital Thermometer	Fluke	2166A	42032	CAL 7/19/04	7/19/06
Thermometer	Traulsen	SK-128		CHAR 1/22/02	1/22/04
Thermometer	Extech	4028	14871-2	CAL 3/7/03	3/7/05
Hygro-Thermometer	Extech	445703	0602	CAL 10/4/02	10/4/04
Frequency Counter	HP	5352B	2632A00165	CAL 8/3/04	8/3/06
Frequency Counter	HP	5385A	2730A03025	CAL 3/7/03	3/7/05
Service Monitor	IFR	FM/AM 500A	5182	CAL 11/22/00	Out of Service
Comm. Serv. Monitor	IFR	FM/AM 1200S	6593	CAL 5/12/02	5/12/04
Signal Generator	HP	8640B	2308A21464	CAL 8/26/04	8/26/06
Sweep Generator	Wiltron	6648	101009	CAL 4/15/03	4/15/05
Sweep Generator	Wiltron	6669M	007005	CAL 3/3/03	3/3/05
Modulation Analyzer	HP	8901A	3435A06868	CAL 9/5/01	9/5/03
Modulation Meter	Boonton	8220	10901AB	CAL 4/15/03	4/15/05
Near Field Probe	HP	HP11940A	2650A02748	CHAR 2/1/01	Out of Service
BandReject Filter	Lorch	5BR4-	Z1	CHAR	4/17/05

APPLICANT: RELM WIRELESS CORPORATION

FCC ID: ARURPU416B

REPORT #: R\RELM_ARU\1588AUT4\1588AUT4TestReport.doc

TIMCO ENGINEERING INC.

849 NW State Road 45

Newberry, Florida 32669

<http://www.timcoengr.com>

888.472.2424 F 352.472.2030 email: sid@timcoengr.com

Device	Manufacturer	Model	Serial Number	Cal/Char Date	Due Date or Status
	Microwave	2400/60-N		4/17/03	
BandReject Filter	Lorch Microwave	6BR6-2442/300-N	Z1	CHAR 4/17/03	4/17/05
BandReject Filter	Lorch Microwave	5BR4-10525/900-S	Z1	CHAR 4/12/03	4/12/05
Notch Filter	Lorch Microwave	5BRX-850/X100-N	AD-1	CHAR 4/17/03	4/17/05
High Pass Filter	Unk	3768(5)-400	041	CHAR 12/17/02	12/17/04
High Pass Filter	Microlab	HA-10N		CHAR 11/17/02	11/17/04
High Pass Filter	Microlab	HA-20N		CHAR 12/17/02	12/17/04
Audio Oscillator	HP	653A	832-00260	CHAR 12/1/02	12/1/04
Audio Generator	B&K Precision	3010	8739686	CHAR 12/1/02	12/1/04
Frequency Counter	HP	5382A	1620A03535	CHAR 3/2/01	Out of Service
Frequency Counter	HP	5385A	3242A07460	CAL 3/7/03	3/7/05
Amplifier	HP	11975A	2738A01969	No Cal Required	
Egg Timer	Unk			CHAR 2/1/02	2/1/04
Measuring Tape-20M	Kraftixx	0631-20		CHAR 2/1/02	2/1/04
Measuring Tape-7.5M	Kraftixx	7.5M PROFI		CHAR 2/1/02	2/1/04
Coaxial Cable #51	Insulated Wire Inc.	NPS 2251-2880	Timco #51	CHAR 1/23/02	1/23/04
Coaxial Cable #64	Semflex Inc.	60637	Timco #64	CHAR 1/24/02	1/24/04
Coaxial Cable #65	General Cable Co.	E9917 RG233/U	Timco #65	CHAR 1/23/02	1/23/04
Coaxial Cable #106	Unknown	Unknown	Timco #106	CHAR 1/23/02	1/23/04
Injection Probe	Fischer Custom Communications	F-120-9A	270	CAL 6/1/01	6/1/03
Power Line Coupling/Decoupling Network	Fischer Custom Communications	FCC-801-M2-16A	01048	CAL 8/29/01	8/29/03
Power Line	Fischer Custom	FCC-801-M3-	01060	CAL	8/29/03

APPLICANT: RELM WIRELESS CORPORATION

FCC ID: ARURPU416B

REPORT #: R\RELM_ARU\1588AUT4\1588AUT4TestReport.doc

TIMCO ENGINEERING INC.

849 NW State Road 45
 Newberry, Florida 32669
<http://www.timcoengr.com>
 888.472.2424 F 352.472.2030 email: sid@timcoengr.com

Device	Manufacturer	Model	Serial Number	Cal/Char Date	Due Date or Status
Coupling/Decoupling Network	Communications	16A		8/29/01	
VHF/UHF Current Probe	Fischer Custom Communications	F-52	130	CAL 8/30/01	8/30/03
Passive Impedance Adapter	Fischer Custom Communications	FCC-801-150-50-CDN	01117 & 01118	CAL 8/29/01	8/29/03
Radiating Field Coil	Fischer Custom Communications	F-1000-4-8/9/10-L-1M	9859	CAL 10/15/98	10/15/00
EMC Immunity Test System	Keytek	CEMASTER	9810210	CAL 2/1/02	2/1/04
Compliance Test System - AC Power Source	California Instruments	1251RP	L05865	CAL 2/25/04	2/25/06
Compliance Test System - PACS-1 Module	California Instruments	PACS-1	X71484	CAL 2/25/04	2/25/06
Isotropic Field Probe	Amplifier Research	FP5000	22839		
Isotropic Field Probe	Amplifier Research	FP5000	300103		
Capacitor Clamp	Keytek	CM-CCL	9811359	No Cal Required	
Amplifier	Amplifier Research	10W1000B	23117	No Cal Required	
Field Monitor	Amplifier Research	FM5004	22288	No Cal Required	
ELF Meter	F. W. Bell	4060	Not Serialized		Out of Service
Standard Gain Horn 1.0-2.4 GHz	Polarad	CA-L	235	No Cal Required	
Standard Gain Horn 2.14-4.34 GHz	Polarad	CA-S	203	No Cal Required	
Standard Gain Horn 3.95-5.85 GHz	Scientific-Atlanta Inc.	11A-3.9	8448CG	No Cal Required	
Standard Gain Horn 8.2-12.5 GHz	Systron Donner	DBG-520-20	Not Serialized	No Cal Required	
Standard Gain Horn 18.0-26.3 GHz	Systron Donner	DBE-520-20	Not Serialized	No Cal Required	
Standard Gain Horn 26.5-40.2 GHz	Systron Donner	DBD-520-20	Not Serialized	No Cal Required	
Standard Gain Horn 40.0-60.0 GHz	ATM	19-443-6R	Not Serialized	No Cal Required	
Double-Ridged Horn	EMCO	3116	9011-2145		Out of

APPLICANT: RELM WIRELESS CORPORATION

FCC ID: ARURPU416B

REPORT #: R\RELM_ARU\1588AUT4\1588AUT4TestReport.doc

TIMCO ENGINEERING INC.

849 NW State Road 45

Newberry, Florida 32669

<http://www.timcoengr.com>

888.472.2424 F 352.472.2030 email: sid@timcoengr.com

Device	Manufacturer	Model	Serial Number	Cal/Char Date	Due Date or Status
Antenna					Service
Standard Gain Horn 12.4-18.0 GHz	ATM	62-442-6	D262108-01	No Cal Required	
Standard Gain Horn 5.85-8.2 GHz	ATM	137-442-2	D261908-01	No Cal Required	
AC Voltmeter	HP	400F	0950A05433	CAL 8/13/03	8/13/05
RF Power Amplifier	Ophir RF	5150F	1041 'X1'	No Cal Required	
Electric Field Sensor	Amplifier Research	FP6001	302504		
Electric Field Sensor	Amplifier Research	FP6001	302510	CAL 6/1/04	6/1/06
Surge Generator	Com-Power Corporation	SG-168	25802	CAL 2/27/04	2/27/06
RF Power Amplifier	Ophir RF, Inc.	5150F	1041	CHAR 10/31/03	10/31/05
3-Meter Anechoic Chamber	Panashield	N/A	N/A	Listed 5/12/04	5/11/07
Digital Multimeter	Fluke	77III	79510408	CAL 7/19/04	7/19/06
Open-Frame Tower Spectrum Analyzer	HP	8566B/85662A	2627A03154/2648A14276	CAL 7/9/04	7/9/06
Open-Frame Tower RF Preselector	HP	85685A	3107A01282	CAL 7/9/04	7/9/06
Open-Frame Tower Quasi-Peak Adapter	HP	85650A	2046A00305	CAL 7/9/04	7/9/06
Signal Generator	HP	8648C	3847A04696	CAL 9/27/04	9/27/06

APPLICANT: RELM WIRELESS CORPORATION

FCC ID: ARURPU416B

REPORT #: R\RELM_ARU\1588AUT4\1588AUT4TestReport.doc