



RELM™

TWO-WAY RADIO



**RPV516/RPU416**

**Owner's Manual**

RELM WIRELESS CORPORATION

## **Thank you!**

**We are grateful that you choose RELM for your land mobile applications . We believe this easy-to-use transceiver will provide dependable communications to keep personnel operating at peak efficiency . Please read and understand this manual carefully for efficient operation.**

**Applied model:**

**RPV516: VHF FM Transceiver**

**RPU416: UHF FM Transceiver**

## Contents

User Safety, Training, and General Information .....	1
Compliance with RF Energy Exposure Standards .....	1
FCC Compliance .....	3
<b>Precautions .....</b>	<b>4</b>
<b>Preparations.....</b>	<b>4</b>
Supplied Accessories .....	5
<b>Battery/Antenna and Other Accessories .....</b>	<b>5</b>
Charging the Battery .....	5
Installing/Removing the Battery .....	6
Installing the Antenna .....	7
Installing the Belt Clip .....	7
Installing the Additional Speaker/Microphone .....	7
<b>Getting Acquainted .....</b>	<b>7</b>
<b>Basic Operation.....</b>	<b>8</b>
<b>Auxiliary Functions .....</b>	<b>9</b>
Time-out Timer .....	9
Battery Save .....	9
Low Battery Warning .....	10
Monitor .....	10
CTCSS/DCS .....	10
Two Tone Signaling .....	10
Channel Scan .....	12
Busy Channel Lockout .....	12
<b>Optional Accessories .....</b>	<b>13</b>
<b>Troubleshooting .....</b>	<b>13</b>
<b>Frequency Chart .....</b>	<b>14</b>



## **User Safety, Training, and General Information**

READ THIS IMPORTANT INFORMATION ON SAFE AND EFFICIENT OPERATION BEFORE USING YOUR RELM HANDHELD PORTABLE TWO-WAY RADIO.

### **Compliance with RF Energy Exposure Standards**

Your **RELM** two-way radio is designed and tested to comply with a number of national and international standards and guidelines (listed below) regarding human exposure to radio frequency electromagnetic energy. This radio complies with the IEEE (FCC) and ICNIRP exposure limits for occupational/controlled RF exposure environment at duty cycles of up to 50% talk-50% listen and should be used for occupational use only. In terms of measuring RF energy for compliance with the FCC exposure guidelines, your radio radiates measurable RF energy only while it is transmitting (during talking), not when it is receiving (listening) or in standby mode.

Note: The approved batteries supplied with this radio are rated for a 5-5-90 duty cycle (5% talk-5% listen-90% standby), even though this radio complies with the FCC occupational RF exposure limits at duty cycles of up to 50% talk.

### **Your RELM two-way radio complies with the following of RF energy exposure standards and guidelines:**

- United States Federal Communications Commission, Code of Federal Regulations; 47CFR part 2 sub-part J
- American National Standards Institute (ANS)/Institute of Electrical and Electronic Engineers (IEEE) C95. 1-1992
- Institute of Electrical and Electronic Engineers (IEEE) C95. 1-1999 Edition
- International Commission on Non-Ionizing Radiation Protection (ICNIRP) 1998

- Ministry of Health (Canada) Safety Code 6. Limits of Human Exposure to Radiofrequency Electromagnetic Fields in the Frequency Range from 3kHz to 300GHz, 1999
- Australian Communications Authority Radiocommunications (Electromagnetic Radiation-Human Exposure) Standard 1999 (applicable to wireless phones only)

### **Operational Instructions and Training Guidelines**

To ensure optimal performance and compliance with the occupational/controlled environment RF energy exposure limits in the above standards and guidelines, users should transmit no more than 50% of the time and always adhere to the following procedures:

#### **Transmit and Receive**

To transmit (talk), push the Push-To-Talk (PTT) button; to receive, release the PTT button.

#### **Hand-held radio operation**

Hold the radio in a vertical position with the microphone one to two inches (2.5 to 5 cm) away from the lips.

#### **Body-worn operation**

- Always place the radio in a RELM approved clip, holder, holster, case, or body harness for this product. Use of non-RELM-approved accessories may exceed FCC RF exposure guidelines.
- If you do not use a RELM approved body-worn accessory and are not using the radio in the intended use position in front of the face, then ensure the antenna and the radio are kept 2.5 cm (one inch) from the body when transmitting.

#### **Antennas & Batteries**

- Use only RELM approved, supplied antenna or RELM approved replacement antenna. Unauthorized antennas; modifications, or attachments could damage the radio and may violate FCC regulations.

- Use only RELM approved, supplied batteries or RELM approved replacement batteries. Use of non-RELM-approved batteries may exceed FCC RF exposure guidelines.

### **Approved Accessories**

For a list of RELM approved accessories see the accessories page of this user manual or visit the following website which lists approved accessories: <http://www.RELM.com>

### **FCC Compliance**

This equipment has been tested and found to comply with the limits for a Class B digital device, pursuant to part 15 of the FCC Rules. These limits are designed to provide reasonable protection against harmful interference in a residential installation. This equipment generates, uses and can radiate radio frequency energy and, if not installed and used in accordance with the instructions, may cause harmful interference to radio communications. However, there is no guarantee that interference will not occur in a particular installation. If this equipment does cause harmful interference to radio or television reception, which can be determined by turning the equipment off and on, the user is encouraged to try to correct the interference by one or more of the following measures:

- Reorient or relocate the receiving antenna.
- Increase the separation between the equipment and receiver.
- Connect the equipment into an outlet on a circuit different from that to which the receiver is connected.
- Consult the dealer or an experienced radio/TV technician for help.

### **Industry Canada Compliance**

This Class B digital apparatus complies with Canadian ICES-003. Cet appareil numérique de la classe B est conforme à la norme NMB-003 Canada.

## FCC Requirements

Your radio must be properly licensed by the Federal Communications Commission prior to use. Your RELM Wireless dealer can assist you in meeting these requirements. Your dealer will program each radio with your authorized frequencies, signaling codes, etc., and will be there to meet your communications needs as your system expands.

## Precautions

Only qualified technicians are allowed to maintain this product. Do not use the transceiver or charge a battery in explosive areas such as coal gas, dust, steam, etc.

Switch OFF the transceiver while refueling or parking at gas station.

Do not modify or adjust this transceiver without permission.

Do not expose the transceiver to direct sunlight over a long time, nor place it close to heating source.

Do not place the transceiver in excessively dusty, humid areas, nor on unstable surfaces.

**Safety:** It is important that the operator is aware of and understands hazards common to the operation of any transceiver.

## Preparations

Please carefully take the transceiver out of the box. We recommend that you confirm the items listed in the following table before discarding the box. If any items are missing or have been damaged during shipment, file a claim with the carrier immediately.

## Supplied Accessories

Item	Quantity
Antenna (*)	1
BCRP-Battery Charger	1
AC Adapter	1
BPRP1100-Battery Pack (7.2V 1100mAH)	1
Belt Clip	1
Owner's Manual	1
Strap	1

**\*Note:** The RPV516B Antenna mark is shamrock.

The RPV516A Antenna mark is grass green.

The RPU416A Antenna mark is milk white.

## Battery/Antenna and Other Accessories

### Charging the Battery

The battery is not charged in factory, charge it before use. When first charging the battery after purchase or extended storage (more than 2 months), battery capacity is lower than its normal operating capacity. Repeating the charge/discharge cycle two or three times, its capacity will increase to normal.

### Caution:

Do not recharge the battery if it is already fully charged. Doing so may shorten the life of the battery or cause damage to it.

After recharging the battery pack, disconnect it from the charger, otherwise, battery life will be shortened as a result of overcharge.

Please turn OFF the power of the transceiver with a battery before charging. Using the transceiver while charging its battery will interfere with proper charging.



When the operating time of the radio continually decreases even though the battery has been fully and properly charged, replace the battery with a new battery.

Do not short the battery terminals or dispose of the battery by fire. Never remove the case from the battery pack.

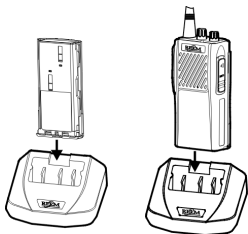

Slide the battery pack or the transceiver with a battery pack into the charger.

- Make sure the battery pack contacts are in contact with the charging terminals .
- Rapid charging starts when the indicator light is red and it finishes when the light is green.

## Installing/Removing the Battery



Match the four grooves of the battery pack with the corresponding guides on the back of the transceiver .

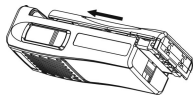

Slide the battery pack along the back of the transceiver until the release latch on the base of the transceiver locks .

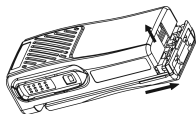

To remove the battery pack , pull back on the release latch and slide the pack away from the transceiver .

## Installing the Antenna

Hold the antenna at its base, screw the antenna into the connector on the top panel of the transceiver.

## Installing the Belt Clip

Position the edge of belt clip on the corresponding grooves on the top of the battery pack. Push the belt clip along the back of the battery pack until the release latch locks.

To remove the belt clip, pull back on the release latch located between the battery pack and the belt clip, and slide the belt clip away from the battery pack.

## Installing Additional Speaker/Microphone

Remove the cover of the speaker/microphone jacks, then insert the speaker/ microphone plugs into the speaker/microphone jacks.

**Note:** The transceiver is not fully water resistant while using speaker/ microphone.

## Getting Acquainted

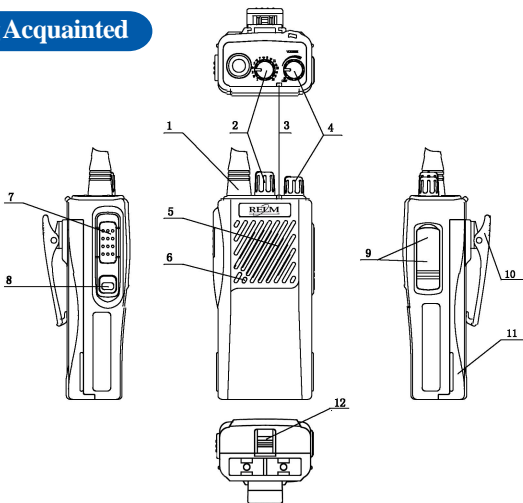

**1. Antenna****2. Channel selector**

Rotate the selector to select channels 1-S (the S channel can be programmed by dealer as scan function)

**3. LED indicator**

Lights red while transmitting. Lights green while receiving a signal. Flashes red when the battery voltage is low while transmitting.

**4. Power/Volume control**

Turn clockwise to switch the power ON. To switch OFF the transceiver, turn counterclockwise until a click sounds. Rotate to adjust the volume.

**5. Speaker****6. Microphone****7. PTT(Press to talk) switch**

Press and hold PTT switch to talk, release to receive.

**8. Monitor key**

Press and hold the key to turn the squelch OFF. You will hear background noise. Release the key to turn the squelch back ON.

**9. Speaker/microphone jacks****10. Belt clip****11. Battery****12. Battery release latch****Basic Operation**

1. Switch ON the transceiver by turning the Power/Volume control clockwise until a beep sounds.
2. To adjust the volume, turn the Power/Volume control knob while pressing the Monitor key.

3. Rotate the Channel selector to select your desired channel. You will hear audio from the speaker when receive an appropriate signal.
4. To make a call, press and hold the PTT switch, then speak into the microphone using your normal speaking voice.  
Keep microphone 3-4cm from your lips.
5. Release the PTT switch to receive.

**Note:** When the battery voltage becomes too low, transmitting stops and red light flashes. Please refer to auxiliary function "Low Battery Warning".

## Auxiliary Functions

### Time-out Timer

Time-out Timer is to prevent one from using the same channel too long and the transceiver from damage due to by continue transmitting.

If you keep the transceiver transmitting signal more than its limited time (set by your dealer, max time is 10 minutes), the transceiver will stop transmitting and a beep will sound. To stop the tone, release the PTT switch. Press the PTT switch again to resume transmitting.

### Battery Save

This function minimizes the amount of power used when a signal is not being received and no operations are being performed (no keys are being pressed, and no switches are being turned).

While the channel is not busy and no operation is performed for 10 seconds, Battery Save turns ON. When a signal is received or an operation is performed, Battery Save turns OFF.

## Low Battery Warning

Low Battery Warning alerts you when the battery needs to be recharged.

While transmitting, if the power of battery goes below a pre-determined value, the red light will flash. When a tone sounds, the transceiver stops transmitting. Please replace or recharge the battery.

## Monitor

The squelch circuit on the transceiver automatically mutes the speaker when no signals are present, so you will not hear background noise. Press and hold "Monitor" key to manually deactivate the squelch. This operation is especially useful for adjusting the volume level or receiving a weak signal.

The LED indicator lights green while the "Monitor" key is pressed.

## CTCSS & DCS

Some channels may have pre-programmed CTCSS/DCS tones. A CTCSS/DCS tone is a sub-audible signal, which allows you to ignore (not hear) calls from other parties using the same channel.

When you receive a signal that has a tone different from the one set up in your transceiver, you will not hear the signal. Likewise, signals that you transmit will only be heard by parties whose CTCSS/DCS tone matches the tone set up in your transceiver.

**Note:** Although using channels set up with CTCSS/DCS tones enables you to avoid hearing those unwanted calls, it does not mean your calls will be private.

## Two Tone Signaling

The Two Tone Signaling (TTS) function is used to control the squelch to turn ON or OFF. It includes two tone call and group call. It can be enabled or disabled by your dealer.

## Receiving

If a signal containing the correct tones is received, the squelch turns OFF and you will hear the call. The following events will occur:

- The LED indicator will flash orange, and then it will light green while receiving the signal.
- If Tone for TTS Squelch has been pre-programmed, an alert tone will sound when the correct tones are received.
- If Transpond for TTS Squelch has been pre-programmed, a tone for acknowledgement will be returned to the caller.
- If TTS auto-reset time has been pre-programmed, the squelch will automatically be switched ON after a specific time, thus, muting the speaker audio.
- Pressing the MONI key will also switch the squelch back ON, thus, muting the speaker audio.

## Transmitting

- Pressing the PTT while pressing the MONI key will transmit the pre-programmed tones.
- The LED indicator remains red while transmitting.
- The transceiver will keep transmitting until the tones are completely sent. After the tones are sent, the squelch switches OFF and the LED indicator flashes orange provided no receive signal is present.
- Pressing the MONI key will switch the squelch back ON, thus, muting the speaker audio.

## **Channel Scan (This function can be programmed as OFF by your dealer)**

Turn the Channel Selector knob to the "S" position. The transceiver automatically checks for activity on those channels(1-15) that have been preprogrammed as scan channels. Your local dealer can program those channels that are desired to be scanned. If a conversation is initiated on any of the channels that the transceiver is scanning, the transceiver will stop on the active channel and you will be able to hear the conversation.

### **Priority channel scan**

Any programmed channel may be set as the priority channel. The transceiver monitors the priority channel while receiving on non-priority channel. When a signal is received on the priority channel, the transceiver will automatically stop on the priority channel to communicate.

### **Revert channel**

When the transceiver is scanning, press the PTT switch, it can transmit in pre-programmed revert channel.

Revert channel can be programmed by your dealer.

### **Busy Channel Lockout**

If the channel you choose is set by your dealer as "busy channel lockout", and this channel is used by other user, pressing PTT causes the transceiver to generate a beep. The transceiver will not transmit in this situation. To stop the beep, release PTT. When this channel is free, press PTT to transmit.

## Optional Accessories

Available optional parts:

- BPRP1100-Battery Pack, 7.2V, 1100mAh
- SMRP-Speaker Microphone
- BCRP-Battery Charger

## Troubleshooting

Trouble	Solution
No power	<ul style="list-style-type: none"> <li>• Battery may be used up. Please change battery or recharge it.</li> <li>• Probably, battery is not properly installed. Remove the battery and install it again.</li> </ul>
Power doesn't last long even if fully charged	Battery may be out of use, please replace it with new battery.
Can't talk to or hear other users in your group	<ul style="list-style-type: none"> <li>• Make sure you are using the same frequency and CTCSS/DCS tone as the other users in your group.</li> <li>• Other group users may be too far away. Make sure you are within range of the other transceiver.</li> </ul>
Other voices (Non-group users) are present on the channel	<ul style="list-style-type: none"> <li>• Change CTCSS/DCS tone. Be sure to change the tone on all transceivers in your group.</li> </ul>



**Frequency Chart**

Model: \_\_\_\_\_

Serial Number: \_\_\_\_\_

Channel	Transmit Frequency	Receive Frequency	CTCSS/DCS
1			
2			
3			
4			
5			
6			
7			
8			
9			
10			
11			
12			
13			
14			
15			
16			



**RELM**<sup>™</sup>

RELM WIRELESS CORPORATION