



A D T

FCC TEST REPORT (WLAN 15.247)

REPORT NO.: RF130614D02

MODEL NO.: WSDB-675GN

FCC ID: ARS-WSDB675GN

RECEIVED: Jun. 14, 2013

TESTED: Jun. 19 ~ Jul. 12, 2013

ISSUED: Aug. 2, 2013

APPLICANT: TOP VICTORY ELECTRONICS (TAIWAN) CO., LTD.

ADDRESS: 10F., No 230, Liancheng Rd., Zhonghe Dist., New Taipei City 23553, Taiwan

ISSUED BY: Bureau Veritas Consumer Products Services (H.K.) Ltd., Taoyuan Branch

LAB ADDRESS: No. 47, 14th Ling, Chia Pau Vil., Lin Kou Dist., New Taipei City, Taiwan

This report should not be used by the client to claim product certification, approval, or endorsement by TAF or any government agencies.



This report is for your exclusive use. Any copying or replication of this report to or for any other person or entity, or use of our name or trademark, is permitted only with our prior written permission. This report sets forth our findings solely with respect to the test samples identified herein. The results set forth in this report are not indicative or representative of the quality or characteristics of the lot from which a test sample was taken or any similar or identical product unless specifically and expressly noted. Our report includes all of the tests requested by you and the results thereof based upon the information that you provided to us. You have 60 days from date of issuance of this report to notify us of any material error or omission caused by our negligence, provided, however, that such notice shall be in writing and shall specifically address the issue you wish to raise. A failure to raise such issue within the prescribed time shall constitute your unqualified acceptance of the completeness of this report, the tests conducted and the correctness of the report contents. Unless specific mention, the uncertainty of measurement has been explicitly taken into account to declare the compliance or non-compliance to the specification.



TABLE OF CONTENTS

- RELEASE CONTROL RECORD5
- 1. CERTIFICATION.....6
- 2. SUMMARY OF TEST RESULTS7
 - 2.1 MEASUREMENT UNCERTAINTY7
- 3. GENERAL INFORMATION8
 - 3.1 GENERAL DESCRIPTION OF EUT8
 - 3.2 DESCRIPTION OF TEST MODES9
 - 3.2.1 TEST MODE APPLICABILITY AND TESTED CHANNEL DETAIL.....10
 - 3.3 DUTY CYCLE OF TEST SIGNAL14
 - 3.4 DESCRIPTION OF SUPPORT UNITS15
 - 3.4.1 CONFIGURATION OF SYSTEM UNDER TEST.....15
 - 3.5 GENERAL DESCRIPTION OF APPLIED STANDARDS.....16
- 4. TEST TYPES AND RESULTS (FOR 2.4GHz BAND)17
 - 4.1 RADIATED EMISSION AND BANDEDGE MEASUREMENT17
 - 4.1.1 LIMITS OF RADIATED EMISSION AND BANDEDGE MEASUREMENT17
 - 4.1.2 TEST INSTRUMENTS.....18
 - 4.1.3 TEST PROCEDURES19
 - 4.1.4 DEVIATION FROM TEST STANDARD.....19
 - 4.1.5 TEST SETUP.....20
 - 4.1.6 EUT OPERATING CONDITIONS20
 - 4.1.7 TEST RESULTS21
 - 4.2 CONDUCTED EMISSION MEASUREMENT.....31
 - 4.2.1 LIMITS OF CONDUCTED EMISSION MEASUREMENT31
 - 4.2.2 TEST INSTRUMENTS.....31
 - 4.2.3 TEST PROCEDURES32
 - 4.2.4 DEVIATION FROM TEST STANDARD.....32
 - 4.2.5 TEST SETUP.....32
 - 4.2.6 EUT OPERATING CONDITIONS32
 - 4.2.7 TEST RESULTS33
 - 4.3 6dB BANDWIDTH MEASUREMENT35
 - 4.3.1 LIMITS OF 6dB BANDWIDTH MEASUREMENT35
 - 4.3.2 TEST SETUP.....35
 - 4.3.3 TEST INSTRUMENTS.....35
 - 4.3.4 TEST PROCEDURE.....35
 - 4.3.5 DEVIATION FROM TEST STANDARD.....35
 - 4.3.6 EUT OPERATING CONDITIONS35
 - 4.3.7 TEST RESULTS36



- 4.4 CONDUCTED OUTPUT POWER.....37
 - 4.4.1 LIMITS OF CONDUCTED OUTPUT POWER MEASUREMENT.....37
 - 4.4.2 TEST SETUP.....37
 - 4.4.3 TEST INSTRUMENTS.....37
 - 4.4.4 TEST PROCEDURES.....37
 - 4.4.5 DEVIATION FROM TEST STANDARD.....37
 - 4.4.6 EUT OPERATING CONDITIONS.....37
 - 4.4.7 TEST RESULTS.....38
- 4.5 POWER SPECTRAL DENSITY MEASUREMENT.....39
 - 4.5.1 LIMITS OF POWER SPECTRAL DENSITY MEASUREMENT.....39
 - 4.5.2 TEST SETUP.....39
 - 4.5.3 TEST INSTRUMENTS.....39
 - 4.5.4 TEST PROCEDURE.....39
 - 4.5.5 DEVIATION FROM TEST STANDARD.....39
 - 4.5.6 EUT OPERATING CONDITION.....39
 - 4.5.7 TEST RESULTS.....40
- 4.6 CONDUCTED OUT OF BAND EMISSION MEASUREMENT.....41
 - 4.6.1 LIMITS OF CONDUCTED OUT OF BAND EMISSION MEASUREMENT.....41
 - 4.6.2 TEST SETUP.....41
 - 4.6.3 TEST INSTRUMENTS.....41
 - 4.6.4 TEST PROCEDURE.....41
 - 4.6.5 DEVIATION FROM TEST STANDARD.....42
 - 4.6.6 EUT OPERATING CONDITION.....42
 - 4.6.7 TEST RESULTS.....42
- 5. TEST TYPES AND RESULTS (FOR 5.0GHZ BAND).....46
 - 5.1 RADIATED EMISSION MEASUREMENT.....46
 - 5.1.1 LIMITS OF RADIATED EMISSION MEASUREMENT.....46
 - 5.1.2 TEST INSTRUMENTS.....47
 - 5.1.3 TEST PROCEDURES.....47
 - 5.1.4 DEVIATION FROM TEST STANDARD.....47
 - 5.1.5 TEST SETUP.....47
 - 5.1.6 EUT OPERATING CONDITIONS.....47
 - 5.1.7 TEST RESULTS.....48
 - 5.2 CONDUCTED EMISSION MEASUREMENT.....55
 - 5.2.1 LIMITS OF CONDUCTED EMISSION MEASUREMENT.....55
 - 5.2.2 TEST INSTRUMENTS.....55
 - 5.2.3 TEST PROCEDURES.....55
 - 5.2.4 DEVIATION FROM TEST STANDARD.....55
 - 5.2.5 TEST SETUP.....55



5.2.6	EUT OPERATING CONDITIONS	55
5.2.7	TEST RESULTS	56
5.3	6dB BANDWIDTH MEASUREMENT	58
5.3.1	LIMITS OF 6dB BANDWIDTH MEASUREMENT	58
5.3.2	TEST SETUP	58
5.3.3	TEST INSTRUMENTS	58
5.3.4	TEST PROCEDURE	58
5.3.5	DEVIATION FROM TEST STANDARD	58
5.3.6	EUT OPERATING CONDITIONS	58
5.3.7	TEST RESULTS	59
5.4	CONDUCTED OUTPUT POWER	60
5.4.1	LIMITS OF CONDUCTED OUTPUT POWER MEASUREMENT	60
5.4.2	TEST SETUP	60
5.4.3	INSTRUMENTS	60
5.4.4	TEST PROCEDURES	60
5.4.5	DEVIATION FROM TEST STANDARD	60
5.4.6	EUT OPERATING CONDITIONS	60
5.4.7	TEST RESULTS	61
5.5	POWER SPECTRAL DENSITY MEASUREMENT	62
5.5.1	LIMITS OF POWER SPECTRAL DENSITY MEASUREMENT	62
5.5.2	TEST SETUP	62
5.5.3	TEST INSTRUMENTS	62
5.5.4	TEST PROCEDURE	62
5.5.5	DEVIATION FROM TEST STANDARD	62
5.5.6	EUT OPERATING CONDITION	62
5.5.7	TEST RESULTS	63
5.6	CONDUCTED OUT OF BAND EMISSION MEASUREMENT	64
5.6.1	LIMITS OF CONDUCTED OUT OF BAND EMISSION MEASUREMENT	64
5.6.2	TEST SETUP	64
5.6.3	TEST INSTRUMENTS	64
5.6.4	TEST PROCEDURE	64
5.6.5	DEVIATION FROM TEST STANDARD	64
5.6.6	EUT OPERATING CONDITION	64
5.6.7	TEST RESULTS	64
6.	PHOTOGRAPHS OF THE TEST CONFIGURATION	67
7.	INFORMATION ON THE TESTING LABORATORIES	68
8.	APPENDIX A – MODIFICATIONS RECORDERS FOR ENGINEERING CHANGES TO THE EUT BY THE LAB	69



A D T

RELEASE CONTROL RECORD

ISSUE NO.	REASON FOR CHANGE	DATE ISSUED
RF130614D02	Original release	Aug. 2, 2013



A D T

1. CERTIFICATION

PRODUCT: 802.11a/b/g/n +Bluetooth 4.0(HS) 1T1R SDIO Module
MODEL NO.: WSDB-675GN
BRAND: TPV
APPLICANT: TOP VICTORY ELECTRONICS (TAIWAN) CO., LTD.
TESTED: Jun. 19 ~ Jul. 12, 2013
TEST SAMPLE: R&D SAMPLE
STANDARDS: **FCC Part 15, Subpart C (Section 15.247)**
ANSI C63.10-2009

The above equipment has been tested by **Bureau Veritas Consumer Products Services (H.K.) Ltd., Taoyuan Branch**, and found compliance with the requirement of the above standards. The test record, data evaluation & Equipment Under Test (EUT) configurations represented herein are true and accurate accounts of the measurements of the sample's EMC characteristics under the conditions specified in this report.

PREPARED BY : Annie Chang , **DATE:** Aug. 2, 2013
(Annie Chang / Supervisor)

APPROVED BY : Ken Liu , **DATE:** Aug. 2, 2013
(Ken Liu / Senior Manager)



2. SUMMARY OF TEST RESULTS

The EUT has been tested according to the following specifications:

APPLIED STANDARD: FCC PART 15, SUBPART C (SECTION 15.247)			
STANDARD SECTION	TEST TYPE	RESULT	REMARK
15.207	AC Power Conducted Emission	PASS	Meet the requirement of limit. Minimum passing margin is -6.90dB at 16.89559MHz.
15.247(d) 15.209	Radiated Emissions	PASS	Meet the requirement of limit. Minimum passing margin is -2.0dB at 5725.00MHz.
15.247(d)	Band Edge Measurement	PASS	Meet the requirement of limit.
15.247(a)(2)	6dB bandwidth	PASS	Meet the requirement of limit.
15.247(b)	Conducted power	PASS	Meet the requirement of limit.
15.247(e)	Power Spectral Density	PASS	Meet the requirement of limit.
15.203	Antenna Requirement	PASS	Antenna connector is I-PEX not a standard connector.

2.1 MEASUREMENT UNCERTAINTY

Where relevant, the following measurement uncertainty levels have been estimated for tests performed on the EUT as specified in CISPR 16-4-2:

Measurement	Frequency	Uncertainty
Conducted emissions	150kHz~30MHz	2.41 dB
Radiated emissions	30MHz ~ 1GHz	4.30 dB
	Above 1GHz	3.36 dB

This uncertainty represents an expanded uncertainty expressed at approximately the 95% confidence level using a coverage factor of $k = 2$.



A D T

3. GENERAL INFORMATION

3.1 GENERAL DESCRIPTION OF EUT

EUT	802.11a/b/g/n +Bluetooth 4.0(HS) 1T1R SDIO Module
MODEL NO.	WSDB-675GN
POWER SUPPLY	5.0Vdc from host equipment
MODULATION TYPE	CCK, DQPSK, DBPSK for DSSS 64QAM, 16QAM, QPSK, BPSK for OFDM
MODULATION TECHNOLOGY	DSSS, OFDM
TRANSFER RATE	802.11b: 11/ 5.5/ 2/ 1Mbps 802.11g: 54/ 48/ 36/ 24/ 18/ 12/ 9/ 6Mbps 802.11a: 54/ 48/ 36/ 24/ 18/ 12/ 9/ 6Mbps 802.11n: up to 72.2Mbps
OPERATING FREQUENCY	2.4GHz: 2412 ~ 2462MHz 5.0GHz: 5745 ~ 5825MHz
NUMBER OF CHANNEL	2.4GHz: 11 5.0GHz: 5
OUTPUT POWER	201.4mW for 2412 ~ 2462MHz 99.1mW for 5745 ~ 5825MHz
ANTENNA TYPE	2.4GHz: PIFA antenna with 1.52dBi gain 5.0GHz: PIFA antenna with 5.19dBi gain
ANTENNA CONNECTOR	I-PEX connector
DATA CABLE	N/A
I/O PORTS	N/A
ACCESSORY DEVICES	N/A

NOTE:

1. The EUT provides one completed transmitter and one receiver.

MODULATION MODE	TX FUNCTION
802.11b	1TX
802.11g	1TX
802.11a	1TX
802.11n (20MHz)	1TX

2. The above EUT information is declared by manufacturer and for more detailed features description, please refer to the manufacturer's specifications or user's manual.

3.2 DESCRIPTION OF TEST MODES

FOR 2.4GHz:

11 channels are provided for 802.11b, 802.11g and 802.11n (20MHz):

CHANNEL	FREQUENCY	CHANNEL	FREQUENCY
1	2412MHz	7	2442MHz
2	2417MHz	8	2447MHz
3	2422MHz	9	2452MHz
4	2427MHz	10	2457MHz
5	2432MHz	11	2462MHz
6	2437MHz		

FOR 5.0GHz (5745 ~ 5825MHz):

5 channels are provided for 802.11a, 802.11n (20MHz):

CHANNEL	FREQUENCY	CHANNEL	FREQUENCY
149	5745MHz	161	5805MHz
153	5765MHz	165	5825MHz
157	5785MHz		

3.2.1 TEST MODE APPLICABILITY AND TESTED CHANNEL DETAIL

FOR 2.4GHz:

EUT CONFIGURE MODE	APPLICABLE TO				DESCRIPTION
	RE≥1G	RE<1G	PLC	APCM	
-	√	√	√	√	-

Where **RE≥1G**: Radiated Emission above 1GHz **RE<1G**: Radiated Emission below 1GHz
PLC: Power Line Conducted Emission **APCM**: Antenna Port Conducted Measurement

NOTE: The EUT had been pre-tested on the positioned of X, Z axis. The worst case was found when positioned on Z-plane.

RADIATED EMISSION TEST (ABOVE 1GHz):

- Pre-Scan has been conducted to determine the worst-case mode from all possible combinations between available modulations, data rates and antenna ports (if EUT with antenna diversity architecture).
- Following channel(s) was (were) selected for the final test as listed below.

EUT CONFIGURE MODE	MODE	AVAILABLE CHANNEL	TESTED CHANNEL	MODULATION TECHNOLOGY	MODULATION TYPE	DATA RATE (Mbps)
-	802.11b	1 to 11	1, 6, 11	DSSS	DBPSK	1.0
-	802.11g	1 to 11	1, 6, 11	OFDM	BPSK	6.0
-	802.11n (20MHz)	1 to 11	1, 6, 11	OFDM	BPSK	7.2

RADIATED EMISSION TEST (BELOW 1GHz):

- Pre-Scan has been conducted to determine the worst-case mode from all possible combinations between available modulations, data rates and antenna ports (if EUT with antenna diversity architecture).
- Following channel(s) was (were) selected for the final test as listed below.

EUT CONFIGURE MODE	MODE	AVAILABLE CHANNEL	TESTED CHANNEL	MODULATION TECHNOLOGY	MODULATION TYPE	DATA RATE (Mbps)
-	802.11g	1 to 11	11	OFDM	BPSK	6.0

POWER LINE CONDUCTED EMISSION TEST:

- Pre-Scan has been conducted to determine the worst-case mode from all possible combinations between available modulations, data rates and antenna ports (if EUT with antenna diversity architecture).
- Following channel(s) was (were) selected for the final test as listed below.

EUT CONFIGURE MODE	MODE	AVAILABLE CHANNEL	TESTED CHANNEL	MODULATION TECHNOLOGY	MODULATION TYPE	DATA RATE (Mbps)
-	802.11g	1 to 11	11	OFDM	BPSK	6.0



BANDEDGE MEASUREMENT:

- Pre-Scan has been conducted to determine the worst-case mode from all possible combinations between available modulations, data rates and antenna ports (if EUT with antenna diversity architecture).
- Following channel(s) was (were) selected for the final test as listed below.

EUT CONFIGURE MODE	MODE	AVAILABLE CHANNEL	TESTED CHANNEL	MODULATION TECHNOLOGY	MODULATION TYPE	DATA RATE (Mbps)
-	802.11b	1 to 11	1, 11	DSSS	DBPSK	1.0
-	802.11g	1 to 11	1, 11	OFDM	BPSK	6.0
-	802.11n (20MHz)	1 to 11	1, 11	OFDM	BPSK	7.2

ANTENNA PORT CONDUCTED MEASUREMENT:

- This item includes all test value of each mode, but only includes spectrum plot of worst value of each mode.
- Pre-Scan has been conducted to determine the worst-case mode from all possible combinations between available modulations, data rates and antenna ports (if EUT with antenna diversity architecture).
- Following channel(s) was (were) selected for the final test as listed below.

EUT CONFIGURE MODE	MODE	AVAILABLE CHANNEL	TESTED CHANNEL	MODULATION TECHNOLOGY	MODULATION TYPE	DATA RATE (Mbps)
-	802.11b	1 to 11	1, 6, 11	DSSS	DBPSK	1.0
-	802.11g	1 to 11	1, 6, 11	OFDM	BPSK	6.0
-	802.11n (20MHz)	1 to 11	1, 6, 11	OFDM	BPSK	7.2

TEST CONDITION:

APPLICABLE TO	ENVIRONMENTAL CONDITIONS	INPUT POWER (SYSTEM)	TESTED BY
RE≥1G	27deg. C, 76%RH	120Vac, 60Hz	Saxon Lee
RE<1G	27deg. C, 76% RH	120Vac, 60Hz	Saxon Lee
PLC	25deg. C, 75% RH	120Vac, 60Hz	Dalen Dai
APCM	25deg. C, 60%RH	120Vac, 60Hz	Chad Lee



FOR 5.0GHz (5745 ~ 5825MHz):

EUT CONFIGURE MODE	APPLICABLE TO				DESCRIPTION
	RE≥1G	RE<1G	PLC	APCM	
-	√	√	√	√	-

Where **RE≥1G**: Radiated Emission above 1GHz **RE<1G**: Radiated Emission below 1GHz
PLC: Power Line Conducted Emission **APCM**: Antenna Port Conducted Measurement

NOTE: The EUT had been pre-tested on the positioned of X, Z axis. The worst case was found when positioned on Z-plane.

RADIATED EMISSION TEST (ABOVE 1GHz):

- Pre-Scan has been conducted to determine the worst-case mode from all possible combinations between available modulations, data rates and antenna ports (if EUT with antenna diversity architecture).
- Following channel(s) was (were) selected for the final test as listed below.

EUT CONFIGURE MODE	MODE	AVAILABLE CHANNEL	TESTED CHANNEL	MODULATION TECHNOLOGY	MODULATION TYPE	DATA RATE (Mbps)
-	802.11a	149 to 165	149, 157, 165	OFDM	BPSK	6.0
-	802.11n (20MHz)	149 to 165	149, 157, 165	OFDM	BPSK	7.2

RADIATED EMISSION TEST (BELOW 1GHz):

- Pre-Scan has been conducted to determine the worst-case mode from all possible combinations between available modulations, data rates and antenna ports (if EUT with antenna diversity architecture).
- Following channel(s) was (were) selected for the final test as listed below.

EUT CONFIGURE MODE	MODE	AVAILABLE CHANNEL	TESTED CHANNEL	MODULATION TECHNOLOGY	MODULATION TYPE	DATA RATE (Mbps)
-	802.11a	149 to 165	157	OFDM	BPSK	6.0

POWER LINE CONDUCTED EMISSION TEST:

- Pre-Scan has been conducted to determine the worst-case mode from all possible combinations between available modulations, data rates and antenna ports (if EUT with antenna diversity architecture).
- Following channel(s) was (were) selected for the final test as listed below.

EUT CONFIGURE MODE	MODE	AVAILABLE CHANNEL	TESTED CHANNEL	MODULATION TECHNOLOGY	MODULATION TYPE	DATA RATE (Mbps)
-	802.11a	149 to 165	157	OFDM	BPSK	6.0



BANDEDGE MEASUREMENT:

- Pre-Scan has been conducted to determine the worst-case mode from all possible combinations between available modulations, data rates and antenna ports (if EUT with antenna diversity architecture).
- Following channel(s) was (were) selected for the final test as listed below.

EUT CONFIGURE MODE	MODE	AVAILABLE CHANNEL	TESTED CHANNEL	MODULATION TECHNOLOGY	MODULATION TYPE	DATA RATE (Mbps)
-	802.11a	149 to 165	149, 165	OFDM	BPSK	6.0
-	802.11n (20MHz)	149 to 165	149, 165	OFDM	BPSK	7.2

ANTENNA PORT CONDUCTED MEASUREMENT:

- This item includes all test value of each mode, but only includes spectrum plot of worst value of each mode.
- Pre-Scan has been conducted to determine the worst-case mode from all possible combinations between available modulations, data rates and antenna ports (if EUT with antenna diversity architecture).
- Following channel(s) was (were) selected for the final test as listed below.

EUT CONFIGURE MODE	MODE	AVAILABLE CHANNEL	TESTED CHANNEL	MODULATION TECHNOLOGY	MODULATION TYPE	DATA RATE (Mbps)
-	802.11a	149 to 165	149, 157, 165	OFDM	BPSK	6.0
-	802.11n (20MHz)	149 to 165	149, 157, 165	OFDM	BPSK	7.2

TEST CONDITION:

APPLICABLE TO	ENVIRONMENTAL CONDITIONS	INPUT POWER (SYSTEM)	TESTED BY
RE≥1G	23deg. C, 77% RH	120Vac, 60Hz	Saxon Lee
RE<1G	27deg. C, 76% RH	120Vac, 60Hz	Saxon Lee
PLC	25deg. C, 75% RH	120Vac, 60Hz	Dalen Dai
APCM	25deg. C, 60% RH	120Vac, 60Hz	Chad Lee

3.3 DUTY CYCLE OF TEST SIGNAL

Duty cycle is < 98%, duty factor shall be considered.

802.11b: Duty cycle = $8.54/8.74 = 0.977$, Duty factor = $10 * \log(1/0.977) = 0.10$

802.11g: Duty cycle = $1.39/1.53 = 0.908$, Duty factor = $10 * \log(1/0.908) = 0.42$

802.11n (20MHz): Duty cycle = $1.31/1.47 = 0.891$, Duty factor = $10 * \log(1/0.891) = 0.50$

802.11a: Duty cycle = $1.37/1.46 = 0.938$, Duty factor = $10 * \log(1/0.938) = 0.28$

802.11n (20MHz): Duty cycle = $1.31/1.38 = 0.949$, Duty factor = $10 * \log(1/0.949) = 0.23$

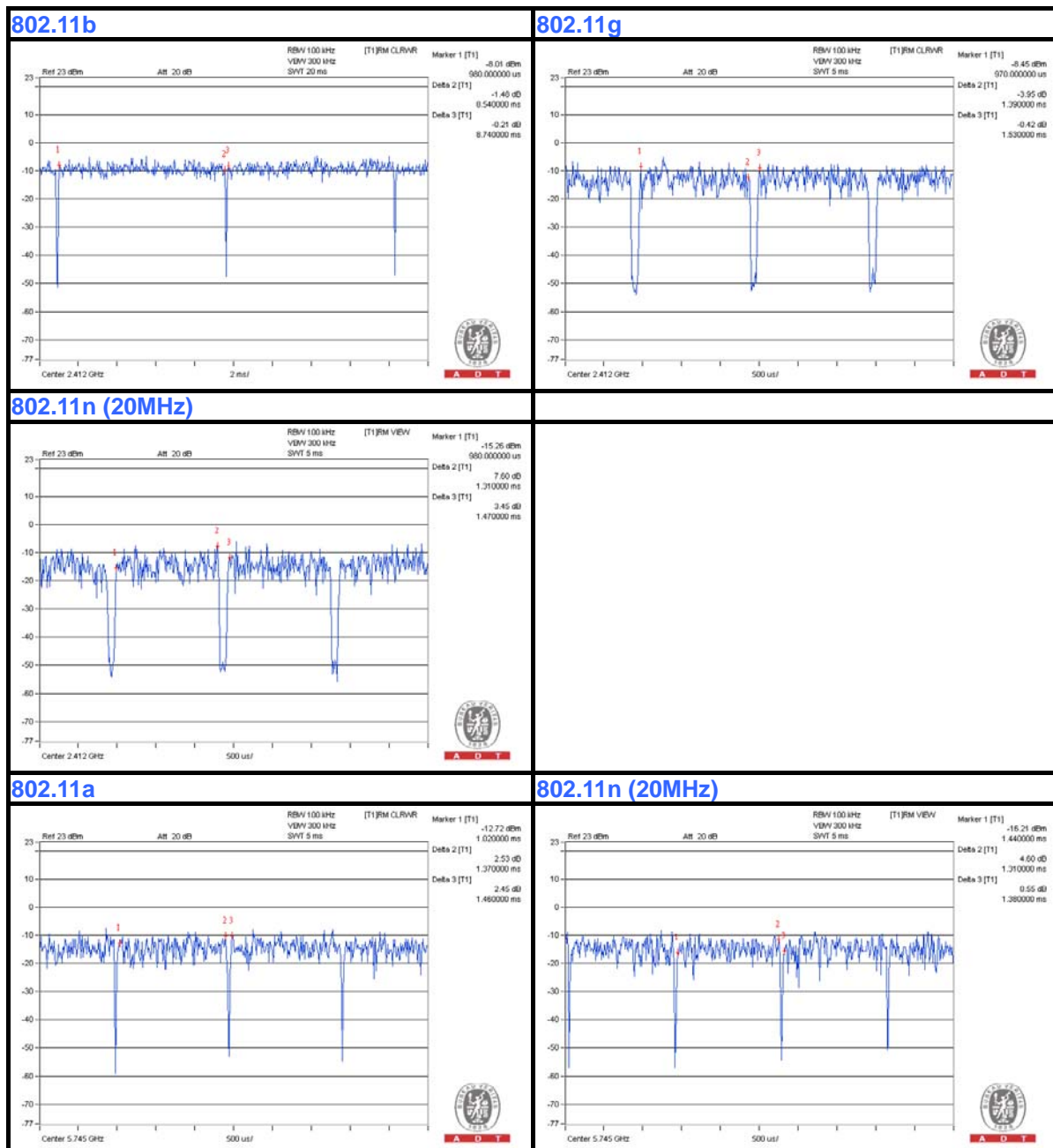

3.4 DESCRIPTION OF SUPPORT UNITS

The EUT has been tested as an independent unit together with other necessary accessories or support units. The following support units or accessories were used to form a representative test configuration during the tests.

NO.	PRODUCT	BRAND	MODEL NO.	SERIAL NO.	FCC ID
1	PERSONAL COMPUTER	ASUS	P5KPL	N/A	FCC DoC Approved
2	LCD MONITOR	DELL	U2410	CN082WXD728 720CC0LGL	FCC DoC Approved
3	USB KEYBOARD	BTC	5200U	G09302046358	E5XKB5122U
4	USB Mouse	Microsoft	1113	9170515772221	FCC DoC Approved

NO.	SIGNAL CABLE DESCRIPTION OF THE ABOVE SUPPORT UNITS
1	1.0m shielded USB cable (Provided by client)
2	1.8m braid shielded wire, terminated with VGA connector via metallic frame, w/. 2 cores
3	1.5 m braid shielded wire, terminated with USB connector via drain wire, w/o core.
4	1.5 m braid shielded wire, terminated with USB connector via drain wire, w/. 1 core.

- NOTE:** 1. All power cords of the above support units are non shielded (1.8m).
 2. The support unit 1 was provided by client.

3.4.1 CONFIGURATION OF SYSTEM UNDER TEST

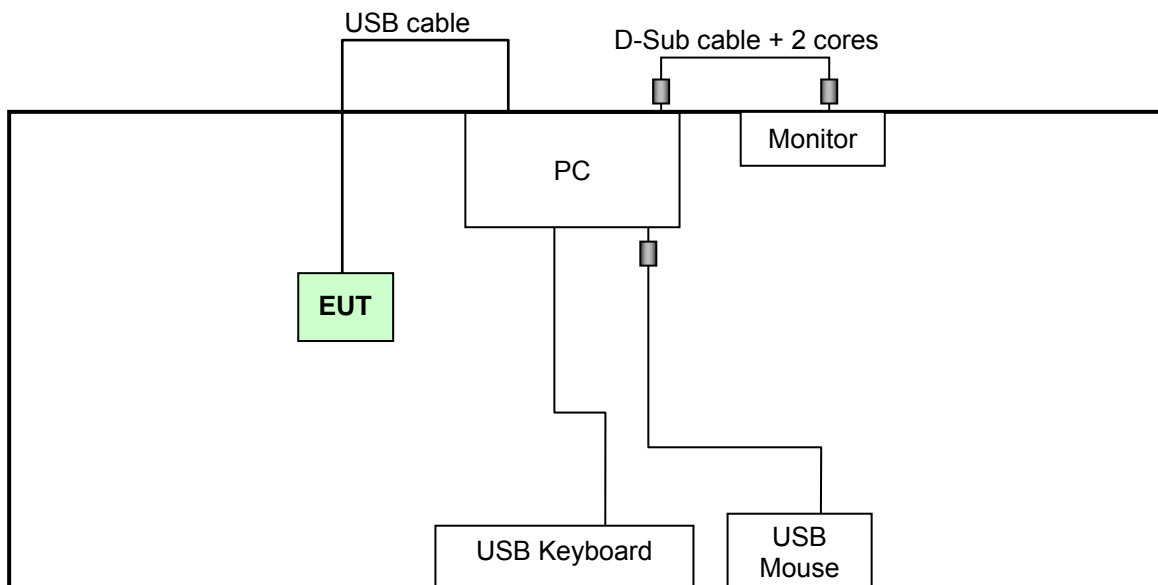



A D T

3.5 GENERAL DESCRIPTION OF APPLIED STANDARDS

The EUT is a RF Product. According to the specifications of the manufacturer, it must comply with the requirements of the following standards:

FCC Part 15, Subpart C (15.247)

558074 D01 DTS Meas Guidance v03r01

ANSI C63.10-2009

All test items have been performed and recorded as per the above standards.

NOTE: The product has been verified to comply with the requirements of FCC Part 15, Subpart B, Class B (DoC). The test report has been issued separately.



4. TEST TYPES AND RESULTS (FOR 2.4GHz BAND)

4.1 RADIATED EMISSION AND BANDEDGE MEASUREMENT

4.1.1 LIMITS OF RADIATED EMISSION AND BANDEDGE MEASUREMENT

Radiated emissions which fall in the restricted bands must comply with the radiated emission limits specified as below table. Other emissions shall be at least 20dB below the highest level of the desired power:

FREQUENCIES (MHz)	FIELD STRENGTH (microvolts/meter)	MEASUREMENT DISTANCE (meters)
0.009 ~ 0.490	2400/F(kHz)	300
0.490 ~ 1.705	24000/F(kHz)	30
1.705 ~ 30.0	30	30
30 ~ 88	100	3
88 ~ 216	150	3
216 ~ 960	200	3
Above 960	500	3

NOTE:

1. The lower limit shall apply at the transition frequencies.
2. Emission level (dBuV/m) = 20 log Emission level (uV/m).
3. For frequencies above 1000MHz, the field strength limits are based on average detector, however, the peak field strength of any emission shall not exceed the maximum permitted average limits, specified above by more than 20dB under any condition of modulation.



A D T

4.1.2 TEST INSTRUMENTS

DESCRIPTION & MANUFACTURER	MODEL NO.	SERIAL NO.	CALIBRATED DATE	CALIBRATED UNTIL
HP Preamplifier	8447D	2432A03504	Feb. 26, 2013	Feb. 25, 2014
HP Preamplifier	8449B	3008A01201	Feb. 26, 2013	Feb. 25, 2014
Agilent TEST RECEIVER	N9038A	MY51210129	Jan. 03, 2013	Jan. 02, 2014
Agilent Spectrum Analyzer	E4446A	MY46180403	Jun. 13, 2013	Jun. 12, 2014
Schwarzbeck Antenna	VULB 9168	137	Mar. 20, 2013	Mar. 19, 2014
Schwarzbeck Antenna	VHBA 9123	480	May 29, 2013	May 28, 2014
ADT. Turn Table	TT100	0306	NA	NA
ADT. Tower	AT100	0306	NA	NA
Software	ADT_Radiated_V 7.6.15.9.2	NA	NA	NA
SUHNER RF cable	SF102	CABLE-CH6	Aug. 19, 2012	Aug. 18, 2013
Schwarzbeck Horn Antenna	BBHA 9120-D1	D130	May 13, 2013	May 12, 2014
Highpass filter Wainwright Instruments	WHK 3.1/18G-10SS	SN 8	NA	NA
ROHDE & SCHWARZ Spectrum Analyzer	FSP 40	100036	May. 17, 2013	May. 16, 2014
Anritsu Power Sensor	MA2411B	0738404	Apr. 24, 2013	Apr. 23, 2014
Anritsu Power Meter	ML2495A	0842014	Apr. 25, 2013	Apr. 24, 2014

- NOTE:**
1. The calibration interval of the above test instruments is 12/24 months. And the calibrations are traceable to NML/ROC and NIST/USA.
 2. The horn antenna and HP preamplifier (model: 8449B) are used only for the measurement of emission frequency above 1GHz if tested.
 3. The test was performed in Chamber No. 6.
 4. The Industry Canada Reference No. IC 7450E-6.
 5. The FCC Site Registration No. is 447212.



A D T

4.1.3 TEST PROCEDURES

- a. The EUT was placed on the top of a rotating table 0.8 meters above the ground at a 3 meters semi-anechoic chamber. The table was rotated 360 degrees to determine the position of the highest radiation.
- b. The EUT was set 3 meters away from the interference-receiving antenna, which was mounted on the top of a variable-height antenna tower.
- c. The antenna is a broadband antenna, and its height is varied from one meter to four meters above the ground to determine the maximum value of the field strength. Both horizontal and vertical polarizations of the antenna are set to make the measurement.
- d. For each suspected emission, the EUT was arranged to its worst case and then the antenna was tuned to heights from 1 meter to 4 meters and the rotatable table was turned from 0 degrees to 360 degrees to find the maximum reading.
- e. The test-receiver system was set to Peak Detect Function and Specified Bandwidth with Maximum Hold Mode.
- f. If the emission level of the EUT in peak mode was lower than the limit specified, then testing could be stopped and the peak values of the EUT would be reported. Otherwise the emissions would be re-tested one by one using peak, quasi-peak or average method as specified and then reported in a data sheet.

NOTE:

1. The resolution bandwidth and video bandwidth of test receiver/spectrum analyzer is 120kHz for Quasi-peak detection at frequency below 1GHz.
2. The resolution bandwidth of test receiver/spectrum analyzer is 100kHz and video bandwidth is 300kHz for Peak detection at frequency above 1GHz.
3. The resolution bandwidth of test receiver/spectrum analyzer is 1MHz and the video bandwidth is 1kHz for Average detection (AV) at frequency above 1GHz.
4. All modes of operation were investigated and the worst-case emissions are reported.

4.1.4 DEVIATION FROM TEST STANDARD

No deviation.

4.1.5 TEST SETUP

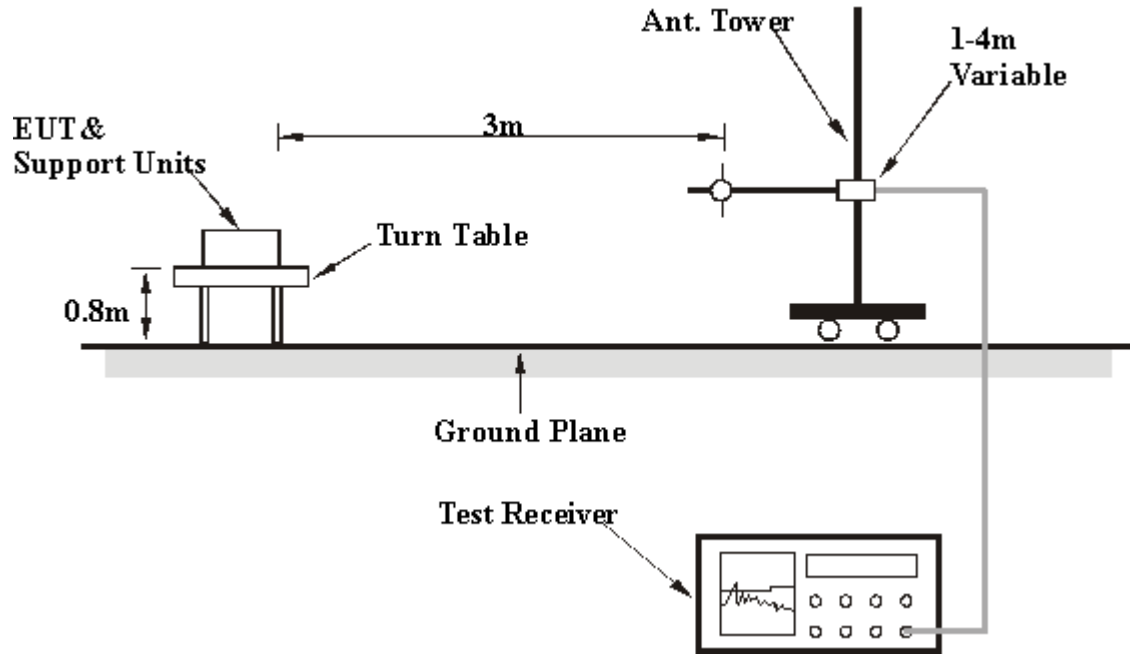

For the actual test configuration, please refer to the attached file (Test Setup Photo).

4.1.6 EUT OPERATING CONDITIONS

Set the EUT under transmission condition continuously at specific channel frequency.



A D T

4.1.7 TEST RESULTS

ABOVE 1GHz DATA

802.11b

CHANNEL	TX Channel 1	DETECTOR FUNCTION	Peak (PK)
FREQUENCY RANGE	1GHz ~ 25GHz		Average (AV)

ANTENNA POLARITY & TEST DISTANCE: HORIZONTAL AT 3 M								
NO.	FREQ. (MHz)	EMISSION LEVEL (dBuV/m)	LIMIT (dBuV/m)	MARGIN (dB)	ANTENNA HEIGHT (m)	TABLE ANGLE (Degree)	RAW VALUE (dBuV)	CORRECTION FACTOR (dB/m)
1	2390.00	56.5 PK	74.0	-17.5	1.00 H	12	60.21	-3.75
2	2390.00	43.9 AV	54.0	-10.1	1.00 H	12	47.66	-3.75
3	*2412.00	103.8 PK			1.00 H	12	107.41	-3.64
4	*2412.00	100.0 AV			1.00 H	12	103.63	-3.64
5	4824.00	46.9 PK	74.0	-27.2	1.00 H	200	43.12	3.73
6	4824.00	40.6 AV	54.0	-13.4	1.00 H	200	36.84	3.73
ANTENNA POLARITY & TEST DISTANCE: VERTICAL AT 3 M								
NO.	FREQ. (MHz)	EMISSION LEVEL (dBuV/m)	LIMIT (dBuV/m)	MARGIN (dB)	ANTENNA HEIGHT (m)	TABLE ANGLE (Degree)	RAW VALUE (dBuV)	CORRECTION FACTOR (dB/m)
1	2390.00	54.4 PK	74.0	-19.6	1.00 V	329	58.18	-3.75
2	2390.00	41.3 AV	54.0	-12.7	1.00 V	329	45.07	-3.75
3	*2412.00	104.2 PK			1.00 V	329	107.85	-3.64
4	*2412.00	100.4 AV			1.00 V	329	104.04	-3.64
5	4824.00	50.4 PK	74.0	-23.7	1.05 V	95	46.62	3.73
6	4824.00	46.0 AV	54.0	-8.0	1.05 V	95	42.26	3.73

REMARKS:

1. Emission Level(dBuV/m) = Raw Value(dBuV) + Correction Factor(dB/m)
2. Correction Factor(dB/m) = Antenna Factor(dB/m) + Cable Factor(dB) – Pre-Amplifier Factor(dB)
3. The other emission levels were very low against the limit.
4. Margin value = Emission Level – Limit value
5. " * ": Fundamental frequency.



A D T

CHANNEL	TX Channel 6	DETECTOR FUNCTION	Peak (PK)
FREQUENCY RANGE	1GHz ~ 25GHz		Average (AV)

ANTENNA POLARITY & TEST DISTANCE: HORIZONTAL AT 3 M								
NO.	FREQ. (MHz)	EMISSION LEVEL (dBuV/m)	LIMIT (dBuV/m)	MARGIN (dB)	ANTENNA HEIGHT (m)	TABLE ANGLE (Degree)	RAW VALUE (dBuV)	CORRECTION FACTOR (dB/m)
1	*2437.00	103.9 PK			1.00 H	10	107.42	-3.53
2	*2437.00	99.7 AV			1.00 H	10	103.27	-3.53
3	4874.00	49.3 PK	74.0	-24.7	1.02 H	188	45.59	3.75
4	4874.00	44.9 AV	54.0	-9.1	1.02 H	188	41.18	3.75
ANTENNA POLARITY & TEST DISTANCE: VERTICAL AT 3 M								
NO.	FREQ. (MHz)	EMISSION LEVEL (dBuV/m)	LIMIT (dBuV/m)	MARGIN (dB)	ANTENNA HEIGHT (m)	TABLE ANGLE (Degree)	RAW VALUE (dBuV)	CORRECTION FACTOR (dB/m)
1	*2437.00	105.5 PK			1.00 V	327	109.02	-3.53
2	*2437.00	101.5 AV			1.00 V	327	104.98	-3.53
3	4874.00	51.2 PK	74.0	-22.8	1.04 V	97	47.48	3.75
4	4874.00	47.6 AV	54.0	-6.4	1.04 V	97	43.82	3.75

REMARKS:

1. Emission Level(dBuV/m) = Raw Value(dBuV) + Correction Factor(dB/m)
2. Correction Factor(dB/m) = Antenna Factor(dB/m) + Cable Factor(dB) – Pre-Amplifier Factor(dB)
3. The other emission levels were very low against the limit.
4. Margin value = Emission Level – Limit value
5. " * ": Fundamental frequency.



A D T

CHANNEL	TX Channel 11	DETECTOR FUNCTION	Peak (PK)
FREQUENCY RANGE	1GHz ~ 25GHz		Average (AV)

ANTENNA POLARITY & TEST DISTANCE: HORIZONTAL AT 3 M								
NO.	FREQ. (MHz)	EMISSION LEVEL (dBuV/m)	LIMIT (dBuV/m)	MARGIN (dB)	ANTENNA HEIGHT (m)	TABLE ANGLE (Degree)	RAW VALUE (dBuV)	CORRECTION FACTOR (dB/m)
1	*2462.00	101.9 PK			1.00 H	46	105.34	-3.41
2	*2462.00	98.1 AV			1.00 H	46	101.52	-3.41
3	2483.50	54.5 PK	74.0	-19.6	1.00 H	46	57.77	-3.32
4	2483.50	45.7 AV	54.0	-8.3	1.00 H	46	49.05	-3.32
5	4924.00	50.9 PK	74.0	-23.1	1.14 H	191	47.18	3.74
6	4924.00	47.5 AV	54.0	-6.5	1.14 H	191	43.80	3.74
ANTENNA POLARITY & TEST DISTANCE: VERTICAL AT 3 M								
NO.	FREQ. (MHz)	EMISSION LEVEL (dBuV/m)	LIMIT (dBuV/m)	MARGIN (dB)	ANTENNA HEIGHT (m)	TABLE ANGLE (Degree)	RAW VALUE (dBuV)	CORRECTION FACTOR (dB/m)
1	*2462.00	105.0 PK			1.00 V	326	108.45	-3.41
2	*2462.00	101.2 AV			1.00 V	326	104.56	-3.41
3	2483.50	58.0 PK	74.0	-16.0	1.00 V	326	61.28	-3.32
4	2483.50	48.9 AV	54.0	-5.1	1.00 V	326	52.24	-3.32
5	4924.00	48.9 PK	74.0	-25.1	1.04 V	181	45.17	3.74
6	4924.00	46.1 AV	54.0	-8.0	1.04 V	181	42.31	3.74

REMARKS:

1. Emission Level(dBuV/m) = Raw Value(dBuV) + Correction Factor(dB/m)
2. Correction Factor(dB/m) = Antenna Factor(dB/m) + Cable Factor(dB) – Pre-Amplifier Factor(dB)
3. The other emission levels were very low against the limit.
4. Margin value = Emission Level – Limit value
5. " * ": Fundamental frequency.



A D T

802.11g

CHANNEL	TX Channel 1	DETECTOR FUNCTION	Peak (PK)
FREQUENCY RANGE	1GHz ~ 25GHz		Average (AV)

ANTENNA POLARITY & TEST DISTANCE: HORIZONTAL AT 3 M								
NO.	FREQ. (MHz)	EMISSION LEVEL (dBuV/m)	LIMIT (dBuV/m)	MARGIN (dB)	ANTENNA HEIGHT (m)	TABLE ANGLE (Degree)	RAW VALUE (dBuV)	CORRECTION FACTOR (dB/m)
1	2390.00	68.7 PK	74.0	-5.3	1.00 H	12	72.49	-3.75
2	2390.00	47.0 AV	54.0	-7.0	1.00 H	12	50.77	-3.75
3	*2412.00	106.3 PK			1.00 H	12	109.93	-3.64
4	*2412.00	91.0 AV			1.00 H	12	94.61	-3.64
5	4824.00	43.4 PK	74.0	-30.6	1.01 H	204	39.69	3.73
6	4824.00	30.5 AV	54.0	-23.5	1.01 H	204	26.81	3.73
ANTENNA POLARITY & TEST DISTANCE: VERTICAL AT 3 M								
NO.	FREQ. (MHz)	EMISSION LEVEL (dBuV/m)	LIMIT (dBuV/m)	MARGIN (dB)	ANTENNA HEIGHT (m)	TABLE ANGLE (Degree)	RAW VALUE (dBuV)	CORRECTION FACTOR (dB/m)
1	2390.00	67.4 PK	74.0	-6.6	1.00 V	329	71.14	-3.75
2	2390.00	48.1 AV	54.0	-5.9	1.00 V	329	51.82	-3.75
3	*2412.00	107.0 PK			1.00 V	329	110.65	-3.64
4	*2412.00	91.4 AV			1.00 V	329	95.05	-3.64
5	4824.00	49.4 PK	74.0	-24.7	1.05 V	94	45.62	3.73
6	4824.00	33.8 AV	54.0	-20.3	1.05 V	94	30.02	3.73

REMARKS:

1. Emission Level(dBuV/m) = Raw Value(dBuV) + Correction Factor(dB/m)
2. Correction Factor(dB/m) = Antenna Factor(dB/m) + Cable Factor(dB) – Pre-Amplifier Factor(dB)
3. The other emission levels were very low against the limit.
4. Margin value = Emission Level – Limit value



A D T

CHANNEL	TX Channel 6	DETECTOR FUNCTION	Peak (PK)
FREQUENCY RANGE	1GHz ~ 25GHz		Average (AV)

ANTENNA POLARITY & TEST DISTANCE: HORIZONTAL AT 3 M								
NO.	FREQ. (MHz)	EMISSION LEVEL (dBuV/m)	LIMIT (dBuV/m)	MARGIN (dB)	ANTENNA HEIGHT (m)	TABLE ANGLE (Degree)	RAW VALUE (dBuV)	CORRECTION FACTOR (dB/m)
1	*2437.00	106.6 PK			1.00 H	10	110.09	-3.53
2	*2437.00	90.5 AV			1.00 H	10	94.07	-3.53
3	4874.00	43.4 PK	74.0	-30.6	1.00 H	201	39.63	3.75
4	4874.00	30.4 AV	54.0	-23.6	1.00 H	201	26.67	3.75
ANTENNA POLARITY & TEST DISTANCE: VERTICAL AT 3 M								
NO.	FREQ. (MHz)	EMISSION LEVEL (dBuV/m)	LIMIT (dBuV/m)	MARGIN (dB)	ANTENNA HEIGHT (m)	TABLE ANGLE (Degree)	RAW VALUE (dBuV)	CORRECTION FACTOR (dB/m)
1	*2437.00	107.4 PK			1.01 V	326	110.91	-3.53
2	*2437.00	92.5 AV			1.01 V	326	95.99	-3.53
3	4874.00	49.4 PK	74.0	-24.6	1.04 V	98	45.66	3.75
4	4874.00	33.8 AV	54.0	-20.2	1.04 V	98	30.07	3.75

REMARKS:

1. Emission Level(dBuV/m) = Raw Value(dBuV) + Correction Factor(dB/m)
2. Correction Factor(dB/m) = Antenna Factor(dB/m) + Cable Factor(dB) – Pre-Amplifier Factor(dB)
3. The other emission levels were very low against the limit.
4. Margin value = Emission Level – Limit value
5. " * ": Fundamental frequency.



A D T

CHANNEL	TX Channel 11	DETECTOR FUNCTION	Peak (PK)
FREQUENCY RANGE	1GHz ~ 25GHz		Average (AV)

ANTENNA POLARITY & TEST DISTANCE: HORIZONTAL AT 3 M								
NO.	FREQ. (MHz)	EMISSION LEVEL (dBuV/m)	LIMIT (dBuV/m)	MARGIN (dB)	ANTENNA HEIGHT (m)	TABLE ANGLE (Degree)	RAW VALUE (dBuV)	CORRECTION FACTOR (dB/m)
1	*2462.00	106.0 PK			1.00 H	27	109.44	-3.41
2	*2462.00	90.0 AV			1.00 H	27	93.41	-3.41
3	2483.50	65.7 PK	74.0	-8.4	1.00 H	27	68.97	-3.32
4	2483.50	46.7 AV	54.0	-7.3	1.00 H	27	50.03	-3.32
5	4924.00	47.5 PK	74.0	-26.5	1.02 H	197	43.79	3.74
6	4924.00	34.7 AV	54.0	-19.3	1.02 H	197	30.95	3.74
ANTENNA POLARITY & TEST DISTANCE: VERTICAL AT 3 M								
NO.	FREQ. (MHz)	EMISSION LEVEL (dBuV/m)	LIMIT (dBuV/m)	MARGIN (dB)	ANTENNA HEIGHT (m)	TABLE ANGLE (Degree)	RAW VALUE (dBuV)	CORRECTION FACTOR (dB/m)
1	*2462.00	108.9 PK			1.00 V	328	112.34	-3.41
2	*2462.00	93.2 AV			1.00 V	328	96.61	-3.41
3	2483.50	68.8 PK	74.0	-5.2	1.00 V	328	72.09	-3.32
4	2483.50	49.4 AV	54.0	-4.6	1.00 V	328	52.74	-3.32
5	4924.00	53.6 PK	74.0	-20.4	1.08 V	176	49.87	3.74
6	4924.00	37.7 AV	54.0	-16.3	1.08 V	176	33.94	3.74

REMARKS:

1. Emission Level(dBuV/m) = Raw Value(dBuV) + Correction Factor(dB/m)
2. Correction Factor(dB/m) = Antenna Factor(dB/m) + Cable Factor(dB) – Pre-Amplifier Factor(dB)
3. The other emission levels were very low against the limit.
4. Margin value = Emission Level – Limit value
5. " * ": Fundamental frequency.



A D T

802.11n (20MHz)

CHANNEL	TX Channel 1	DETECTOR FUNCTION	Peak (PK)
FREQUENCY RANGE	1GHz ~ 25GHz		Average (AV)

ANTENNA POLARITY & TEST DISTANCE: HORIZONTAL AT 3 M								
NO.	FREQ. (MHz)	EMISSION LEVEL (dBuV/m)	LIMIT (dBuV/m)	MARGIN (dB)	ANTENNA HEIGHT (m)	TABLE ANGLE (Degree)	RAW VALUE (dBuV)	CORRECTION FACTOR (dB/m)
1	2390.00	67.4 PK	74.0	-6.6	1.00 H	12	71.12	-3.75
2	2390.00	46.1 AV	54.0	-7.9	1.00 H	12	49.83	-3.75
3	*2412.00	104.3 PK			1.00 H	12	107.91	-3.64
4	*2412.00	89.7 AV			1.00 H	12	93.38	-3.64
5	4824.00	46.1 PK	74.0	-27.9	1.02 H	203	42.36	3.73
6	4824.00	33.9 AV	54.0	-20.1	1.02 H	203	30.13	3.73
ANTENNA POLARITY & TEST DISTANCE: VERTICAL AT 3 M								
NO.	FREQ. (MHz)	EMISSION LEVEL (dBuV/m)	LIMIT (dBuV/m)	MARGIN (dB)	ANTENNA HEIGHT (m)	TABLE ANGLE (Degree)	RAW VALUE (dBuV)	CORRECTION FACTOR (dB/m)
1	2390.00	67.8 PK	74.0	-6.2	1.01 V	330	71.52	-3.75
2	2390.00	46.2 AV	54.0	-7.8	1.01 V	330	49.96	-3.75
3	*2412.00	104.6 PK			1.01 V	330	108.22	-3.64
4	*2412.00	89.5 AV			1.01 V	330	93.09	-3.64
5	4824.00	52.7 PK	74.0	-21.3	1.05 V	96	48.98	3.73
6	4824.00	36.4 AV	54.0	-17.6	1.05 V	96	32.63	3.73

REMARKS:

1. Emission Level(dBuV/m) = Raw Value(dBuV) + Correction Factor(dB/m)
2. Correction Factor(dB/m) = Antenna Factor(dB/m) + Cable Factor(dB) – Pre-Amplifier Factor(dB)
3. The other emission levels were very low against the limit.
4. Margin value = Emission Level – Limit value
5. " * ": Fundamental frequency.



A D T

CHANNEL	TX Channel 6	DETECTOR FUNCTION	Peak (PK)
FREQUENCY RANGE	1GHz ~ 25GHz		Average (AV)

ANTENNA POLARITY & TEST DISTANCE: HORIZONTAL AT 3 M								
NO.	FREQ. (MHz)	EMISSION LEVEL (dBuV/m)	LIMIT (dBuV/m)	MARGIN (dB)	ANTENNA HEIGHT (m)	TABLE ANGLE (Degree)	RAW VALUE (dBuV)	CORRECTION FACTOR (dB/m)
1	*2437.00	104.8 PK			1.00 H	10	108.34	-3.53
2	*2437.00	89.4 AV			1.00 H	10	92.88	-3.53
3	4874.00	46.3 PK	74.0	-27.7	1.00 H	199	42.59	3.75
4	4874.00	34.2 AV	54.0	-19.8	1.00 H	199	30.41	3.75
ANTENNA POLARITY & TEST DISTANCE: VERTICAL AT 3 M								
NO.	FREQ. (MHz)	EMISSION LEVEL (dBuV/m)	LIMIT (dBuV/m)	MARGIN (dB)	ANTENNA HEIGHT (m)	TABLE ANGLE (Degree)	RAW VALUE (dBuV)	CORRECTION FACTOR (dB/m)
1	*2437.00	105.9 PK			1.00 V	329	109.41	-3.53
2	*2437.00	90.8 AV			1.00 V	329	94.31	-3.53
3	4874.00	52.9 PK	74.0	-21.1	1.04 V	113	49.12	3.75
4	4874.00	36.6 AV	54.0	-17.4	1.04 V	113	32.85	3.75

REMARKS:

1. Emission Level(dBuV/m) = Raw Value(dBuV) + Correction Factor(dB/m)
2. Correction Factor(dB/m) = Antenna Factor(dB/m) + Cable Factor(dB) – Pre-Amplifier Factor(dB)
3. The other emission levels were very low against the limit.
4. Margin value = Emission Level – Limit value
5. " * ": Fundamental frequency.



A D T

CHANNEL	TX Channel 11	DETECTOR FUNCTION	Peak (PK)
FREQUENCY RANGE	1GHz ~ 25GHz		Average (AV)

ANTENNA POLARITY & TEST DISTANCE: HORIZONTAL AT 3 M								
NO.	FREQ. (MHz)	EMISSION LEVEL (dBuV/m)	LIMIT (dBuV/m)	MARGIN (dB)	ANTENNA HEIGHT (m)	TABLE ANGLE (Degree)	RAW VALUE (dBuV)	CORRECTION FACTOR (dB/m)
1	*2462.00	104.4 PK			1.00 H	56	107.83	-3.41
2	*2462.00	89.0 AV			1.00 H	56	92.36	-3.41
3	2483.50	63.7 PK	74.0	-10.3	1.00 H	56	67.06	-3.32
4	2483.50	44.6 AV	54.0	-9.4	1.00 H	56	47.96	-3.32
5	4924.00	46.2 PK	74.0	-27.9	1.13 H	198	42.41	3.74
6	4924.00	34.0 AV	54.0	-20.0	1.13 H	198	30.24	3.74
ANTENNA POLARITY & TEST DISTANCE: VERTICAL AT 3 M								
NO.	FREQ. (MHz)	EMISSION LEVEL (dBuV/m)	LIMIT (dBuV/m)	MARGIN (dB)	ANTENNA HEIGHT (m)	TABLE ANGLE (Degree)	RAW VALUE (dBuV)	CORRECTION FACTOR (dB/m)
1	*2462.00	106.4 PK			1.00 V	325	109.77	-3.41
2	*2462.00	91.6 AV			1.00 V	325	95.03	-3.41
3	2483.50	67.0 PK	74.0	-7.0	1.00 V	325	70.32	-3.32
4	2483.50	48.1 AV	54.0	-5.9	1.00 V	325	51.39	-3.32
5	4924.00	52.6 PK	74.0	-21.4	1.10 V	183	48.87	3.74
6	4924.00	36.3 AV	54.0	-17.7	1.10 V	183	32.54	3.74

REMARKS:

1. Emission Level(dBuV/m) = Raw Value(dBuV) + Correction Factor(dB/m)
2. Correction Factor(dB/m) = Antenna Factor(dB/m) + Cable Factor(dB) – Pre-Amplifier Factor(dB)
3. The other emission levels were very low against the limit.
4. Margin value = Emission Level – Limit value
5. " * ": Fundamental frequency.



A D T

BELOW 1GHz WORST-CASE DATA

802.11g

CHANNEL	TX Channel 11	DETECTOR FUNCTION	Quasi-Peak (QP)
FREQUENCY RANGE	30MHz ~ 1GHz		

ANTENNA POLARITY & TEST DISTANCE: HORIZONTAL AT 3 M

NO.	FREQ. (MHz)	EMISSION LEVEL (dBuV/m)	LIMIT (dBuV/m)	MARGIN (dB)	ANTENNA HEIGHT (m)	TABLE ANGLE (Degree)	RAW VALUE (dBuV)	CORRECTION FACTOR (dB/m)
1	57.16	31.6 QP	40.0	-8.4	1.08 H	178	45.81	-14.18
2	115.36	34.0 QP	43.5	-9.5	1.00 H	206	50.11	-16.13
3	167.74	35.2 QP	43.5	-8.3	1.42 H	87	48.63	-13.42
4	270.56	35.1 QP	46.0	-10.9	1.14 H	71	47.49	-12.38
5	335.55	36.4 QP	46.0	-9.6	1.00 H	106	47.10	-10.67
6	801.15	36.1 QP	46.0	-9.9	1.07 H	96	38.01	-1.94

ANTENNA POLARITY & TEST DISTANCE: VERTICAL AT 3 M

NO.	FREQ. (MHz)	EMISSION LEVEL (dBuV/m)	LIMIT (dBuV/m)	MARGIN (dB)	ANTENNA HEIGHT (m)	TABLE ANGLE (Degree)	RAW VALUE (dBuV)	CORRECTION FACTOR (dB/m)
1	57.16	32.3 QP	40.0	-7.7	1.32 V	172	46.44	-14.18
2	115.36	35.7 QP	43.5	-7.8	1.05 V	202	51.86	-16.13
3	167.74	35.0 QP	43.5	-8.5	1.04 V	94	48.45	-13.42
4	270.56	37.0 QP	46.0	-9.0	1.03 V	68	49.39	-12.38
5	408.30	36.8 QP	46.0	-9.2	1.00 V	9	46.29	-9.47
6	798.24	38.9 QP	46.0	-7.2	1.52 V	102	40.83	-1.98

REMARKS:

1. Emission Level(dBuV/m) = Raw Value(dBuV) + Correction Factor(dB/m)
2. Correction Factor(dB/m) = Antenna Factor(dB/m) + Cable Factor(dB) – Pre-Amplifier Factor(dB)
3. The other emission levels were very low against the limit.
4. Margin value = Emission Level – Limit value



4.2 CONDUCTED EMISSION MEASUREMENT

4.2.1 LIMITS OF CONDUCTED EMISSION MEASUREMENT

FREQUENCY OF EMISSION (MHz)	CONDUCTED LIMIT (dBµV)	
	Quasi-peak	Average
0.15 ~ 0.5	66 to 56	56 to 46
0.5 ~ 5	56	46
5 ~ 30	60	50

- NOTE:** 1. The lower limit shall apply at the transition frequencies.
 2. The limit decreases in line with the logarithm of the frequency in the range of 0.15 to 0.50MHz.

4.2.2 TEST INSTRUMENTS

DESCRIPTION & MANUFACTURER	MODEL NO.	SERIAL NO.	CALIBRATED DATE	CALIBRATED UNTIL
ROHDE & SCHWARZ TEST RECEIVER	ESCS 30	100276	Jan. 07, 2013	Jan. 06, 2014
ROHDE & SCHWARZ Artificial Mains Network (for EUT)	ESH3-Z5	100219	Nov. 28, 2012	Nov. 27, 2013
LISN With Adapter (for EUT)	AD10	C10Ada-001	Nov. 28, 2012	Nov. 27, 2013
ROHDE & SCHWARZ Artificial Mains Network (for peripherals)	ESH3-Z5	100218	Dec. 05, 2012	Dec. 04, 2013
Software	ADT_Cond_V7.3.7	NA	NA	NA
Software	ADT_ISN_V7.3.7	NA	NA	NA
RF cable (JYEBAO)	5D-FB	Cable-C10.01	Feb. 19, 2013	Feb. 18, 2014
SUHNER Terminator (For ROHDE & SCHWARZ LISN)	65BNC-5001	E1-010773	Feb. 06, 2013	Feb. 05, 2014

- NOTE:** 1. The calibration interval of the above test instruments is 12 months and the calibrations are traceable to NML/ROC and NIST/USA.
 2. The test was performed in Shielded Room No. 10.
 3. The VCCI Site Registration No. C-1852.

4.2.3 TEST PROCEDURES

- a. The EUT was placed 0.4 meters from the conducting wall of the shielded room with EUT being connected to the power mains through a line impedance stabilization network (LISN). Other support units were connected to the power mains through another LISN. The two LISNs provide 50 ohm/ 50uH of coupling impedance for the measuring instrument.
- b. Both lines of the power mains connected to the EUT were checked for maximum conducted interference.
- c. The frequency range from 150kHz to 30MHz was searched. Emission levels under (Limit - 20dB) was not recorded.

NOTE: All modes of operation were investigated and the worst-case emissions are reported.

4.2.4 DEVIATION FROM TEST STANDARD

No deviation.

4.2.5 TEST SETUP

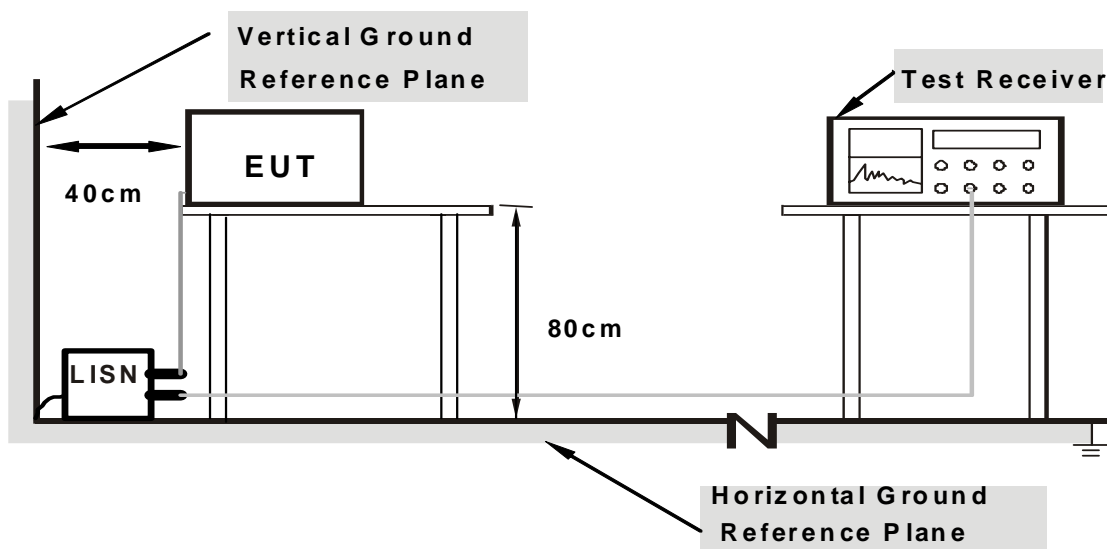

Note: Support units were connected to second LISN.

For the actual test configuration, please refer to the attached file (Test Setup Photo).

4.2.6 EUT OPERATING CONDITIONS

Same as 4.1.6.



A D T

4.2.7 TEST RESULTS

CONDUCTED WORST-CASE DATA : 802.11g

PHASE	Line 1	6dB BANDWIDTH	9kHz
-------	--------	---------------	------

No	Freq. [MHz]	Corr. Factor (dB)	Reading Value		Emission Level		Limit		Margin	
			[dB (uV)]		[dB (uV)]		[dB (uV)]		(dB)	
			Q.P.	AV.	Q.P.	AV.	Q.P.	AV.	Q.P.	AV.
1	0.16760	0.14	38.83	36.44	38.97	36.58	65.08	55.08	-26.11	-18.50
2	0.19521	0.14	46.56	46.37	46.70	46.51	63.81	53.81	-17.11	-7.30
3	0.29453	0.15	31.82	30.58	31.97	30.73	60.40	50.40	-28.42	-19.66
4	13.82371	0.83	36.10	35.63	36.93	36.46	60.00	50.00	-23.07	-13.54
5	16.89559	1.00	43.45	42.10	44.45	43.10	60.00	50.00	-15.55	-6.90
6	29.18359	1.41	30.72	30.58	32.13	31.99	60.00	50.00	-27.87	-18.01

REMARKS:

1. Q.P. and AV. are abbreviations of quasi-peak and average individually.
2. The emission levels of other frequencies were very low against the limit.
3. Margin value = Emission Level – Limit value
4. Correction Factor = Insertion loss + Cable loss
5. Emission Level = Correction Factor + Reading Value

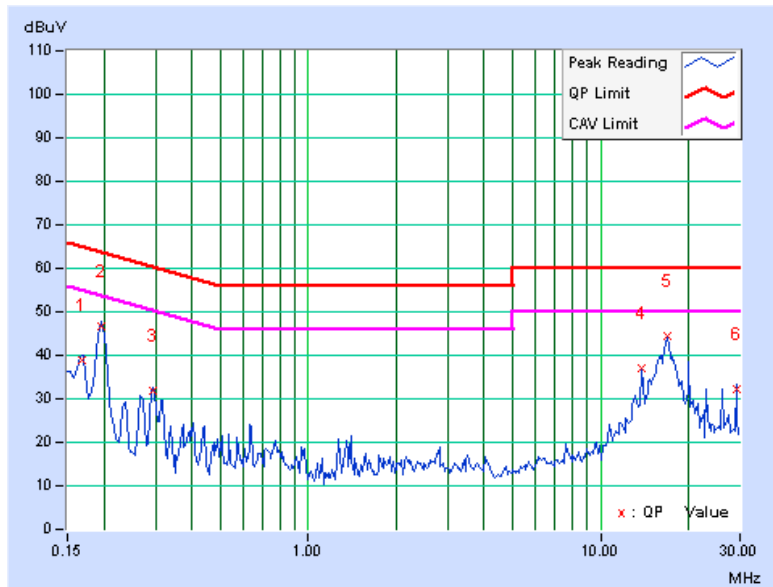

PHASE	Line 2	6dB BANDWIDTH	9kHz
--------------	--------	----------------------	------

No	Freq. [MHz]	Corr. Factor (dB)	Reading Value [dB (uV)]		Emission Level [dB (uV)]		Limit [dB (uV)]		Margin (dB)	
			Q.P.	AV.	Q.P.	AV.	Q.P.	AV.	Q.P.	AV.
			1	0.16855	0.11	44.22	40.40	44.33	40.51	65.03
2	0.19562	0.11	43.51	42.99	43.62	43.10	63.79	53.79	-20.17	-10.69
3	0.30184	0.13	32.13	27.25	32.26	27.38	60.19	50.19	-27.94	-22.82
4	13.82288	0.60	36.14	35.10	36.74	35.70	60.00	50.00	-23.26	-14.30
5	16.89580	0.70	42.92	41.62	43.62	42.32	60.00	50.00	-16.38	-7.68
6	18.94112	0.77	31.59	25.27	32.36	26.04	60.00	50.00	-27.64	-23.96

REMARKS:

1. Q.P. and AV. are abbreviations of quasi-peak and average individually.
2. The emission levels of other frequencies were very low against the limit.
3. Margin value = Emission Level – Limit value
4. Correction Factor = Insertion loss + Cable loss
5. Emission Level = Correction Factor + Reading Value

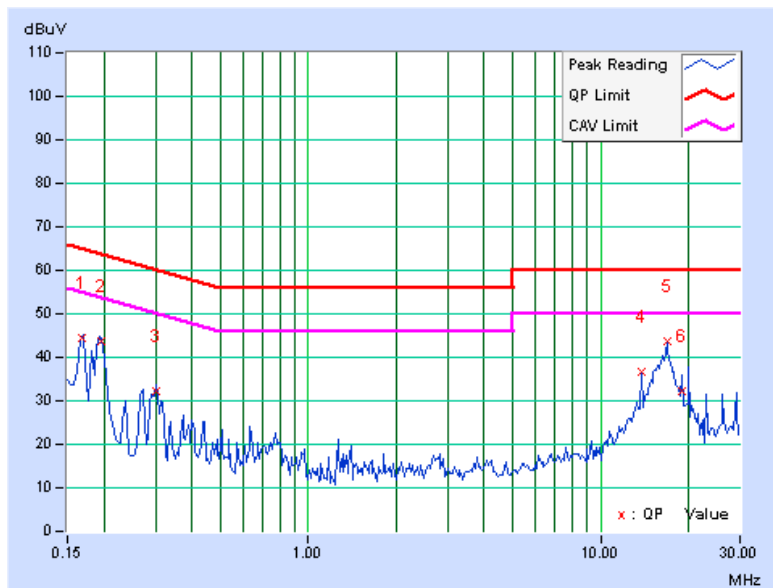

4.3 6dB BANDWIDTH MEASUREMENT

4.3.1 LIMITS OF 6dB BANDWIDTH MEASUREMENT

The minimum of 6dB Bandwidth Measurement is 0.5 MHz.

4.3.2 TEST SETUP

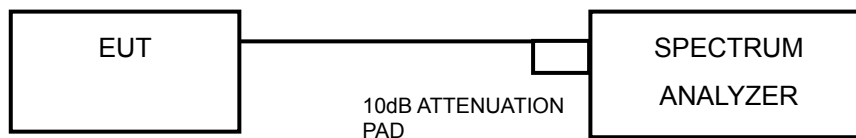

4.3.3 TEST INSTRUMENTS

Refer to section 4.1.2 to get information of above instrument.

4.3.4 TEST PROCEDURE

- a. Set resolution bandwidth (RBW) = 100kHz
- b. Set the video bandwidth (VBW) $\geq 3 \times$ RBW, Detector = Peak.
- c. Trace mode = max hold.
- d. Sweep = auto couple.
- e. Measure the maximum width of the emission that is constrained by the frequencies associated with the two amplitude points (upper and lower) that are attenuated by 6 dB relative to the maximum level measured in the fundamental emission

4.3.5 DEVIATION FROM TEST STANDARD

No deviation.

4.3.6 EUT OPERATING CONDITIONS

The software provided by client to enable the EUT under transmission condition continuously at lowest, middle and highest channel frequencies individually.



4.3.7 TEST RESULTS

CHANNEL	FREQUENCY (MHz)	6dB BANDWIDTH (MHz)	MINIMUM LIMIT (MHz)	PASS / FAIL
802.11b				
1	2412	8.07	0.5	PASS
6	2437	7.65	0.5	PASS
11	2462	7.12	0.5	PASS
802.11g				
1	2412	15.16	0.5	PASS
6	2437	15.12	0.5	PASS
11	2462	15.16	0.5	PASS
802.11n (20MHz)				
1	2412	13.93	0.5	PASS
6	2437	15.16	0.5	PASS
11	2462	15.16	0.5	PASS

4.4 CONDUCTED OUTPUT POWER

4.4.1 LIMITS OF CONDUCTED OUTPUT POWER MEASUREMENT

For systems using digital modulation in the 2400–2483.5 MHz bands: 1 Watt (30dBm)

4.4.2 TEST SETUP

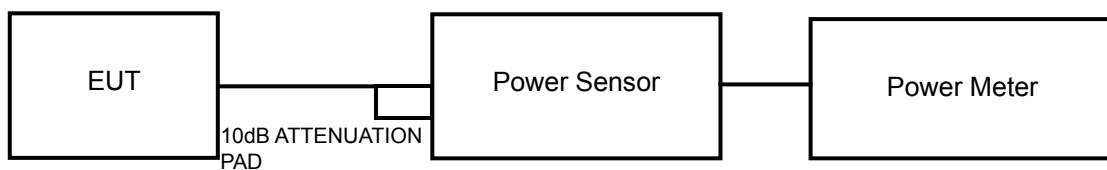

4.4.3 TEST INSTRUMENTS

Refer to section 4.1.2 to get information of above instrument.

4.4.4 TEST PROCEDURES

A peak / average power sensor was used on the output port of the EUT. A power meter was used to read the response of the peak / average power sensor. Record the peak power level.

4.4.5 DEVIATION FROM TEST STANDARD

No deviation.

4.4.6 EUT OPERATING CONDITIONS

Same as Item 4.3.6.



A D T

4.4.7 TEST RESULTS

FOR PEAK POWER

CHANNEL	FREQUENCY (MHz)	PEAK POWER (dBm)	PEAK POWER (mW)	LIMIT (dBm)	PASS/FAIL
802.11b					
1	2412	19.04	80.2	30	PASS
6	2437	19.14	82.0	30	PASS
11	2462	17.48	56.0	30	PASS
802.11g					
1	2412	22.64	183.7	30	PASS
6	2437	23.02	200.4	30	PASS
11	2462	23.04	201.4	30	PASS
802.11n (20MHz)					
1	2412	22.03	159.6	30	PASS
6	2437	22.87	193.6	30	PASS
11	2462	22.91	195.4	30	PASS

FOR AVERAGE POWER

CHANNEL	FREQUENCY (MHz)	AVERAGE POWER (dBm)
802.11b		
1	2412	16.18
6	2437	16.21
11	2462	14.42
802.11g		
1	2412	15.18
6	2437	15.31
11	2462	15.22
802.11n (20MHz)		
1	2412	14.10
6	2437	14.21
11	2462	14.32

4.5 POWER SPECTRAL DENSITY MEASUREMENT

4.5.1 LIMITS OF POWER SPECTRAL DENSITY MEASUREMENT

The Maximum of Power Spectral Density Measurement is 8dBm.

4.5.2 TEST SETUP

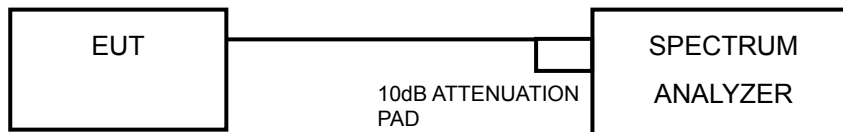

4.5.3 TEST INSTRUMENTS

Refer to section 4.1.2 to get information of above instrument.

4.5.4 TEST PROCEDURE

- Set the RBW = 3 kHz, VBW = 10 kHz, Detector = peak.
- Sweep time = auto couple, Trace mode = max hold, allow trace to fully stabilize.
- Use the peak marker function to determine the maximum power level in any 100 kHz band segment within the fundamental EBW.
- Record the max value and add 10 log (1/duty cycle)

4.5.5 DEVIATION FROM TEST STANDARD

No deviation.

4.5.6 EUT OPERATING CONDITION

Same as Item 4.3.6



4.5.7 TEST RESULTS

CHANNEL	FREQUENCY (MHz)	PSD W/O DUTY FACTOR (dBm)	DUTY FACTOR	PSD WITH DUTY FACTOR (dBm)	MAXIMUM LIMIT (dBm)	PASS/FAIL
802.11b						
1	2412	-4.89	0.10	-4.79	8	PASS
6	2437	-5.19	0.10	-5.09	8	PASS
11	2462	-6.02	0.10	-5.92	8	PASS
802.11g						
1	2412	-8.59	0.42	-8.17	8	PASS
6	2437	-8.37	0.42	-7.95	8	PASS
11	2462	-8.19	0.42	-7.77	8	PASS
802.11n (20MHz)						
1	2412	-10.22	0.50	-9.72	8	PASS
6	2437	-9.39	0.50	-8.89	8	PASS
11	2462	-9.85	0.50	-9.35	8	PASS

Note: Refer to section 3.3 for duty cycle spectrum plot.

4.6 CONDUCTED OUT OF BAND EMISSION MEASUREMENT

4.6.1 LIMITS OF CONDUCTED OUT OF BAND EMISSION MEASUREMENT

Below -20dB of the highest emission level of operating band (in 100kHz Resolution Bandwidth).

4.6.2 TEST SETUP

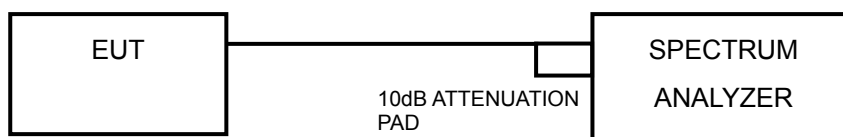

4.6.3 TEST INSTRUMENTS

Refer to section 4.1.2 to get information of above instrument.

4.6.4 TEST PROCEDURE

MEASUREMENT PROCEDURE REF

1. Set the RBW = 100 kHz.
2. Set the VBW \geq 300 kHz.
3. Detector = peak.
4. Sweep time = auto couple.
5. Trace mode = max hold.
6. Allow trace to fully stabilize.
7. Use the peak marker function to determine the maximum power level in any 100 kHz band segment within the fundamental EBW.



A D T

MEASUREMENT PROCEDURE OOB

1. Set RBW = 100 kHz.
2. Set VBW \geq 300 kHz.
3. Set span to encompass the spectrum to be examined.
4. Detector = peak.
5. Trace Mode = max hold.
6. Sweep = auto couple.

4.6.5 DEVIATION FROM TEST STANDARD

No deviation.

4.6.6 EUT OPERATING CONDITION

Same as Item 4.3.6

4.6.7 TEST RESULTS

The spectrum plots are attached on the following pages. D1 line indicates the highest level, and D2 line indicates the 20dB offset below D1. It shows compliance with the requirement.

802.11b

CH 1

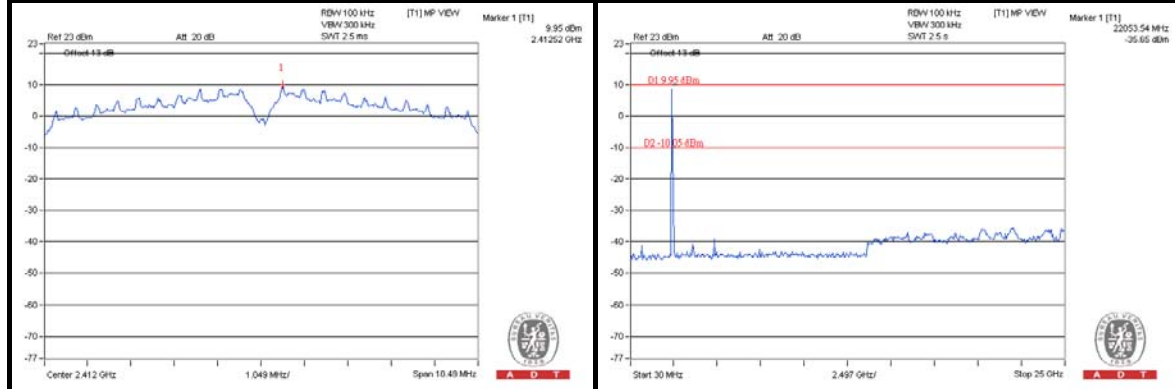

CH 6

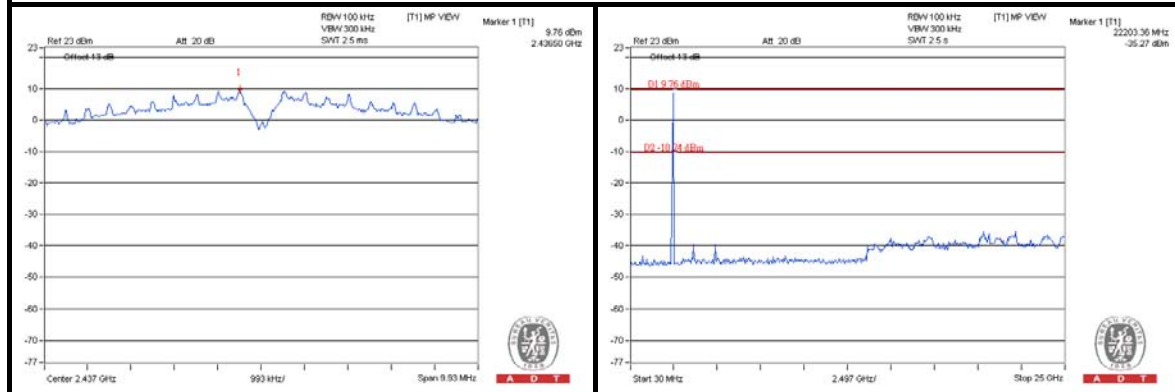

CH 11

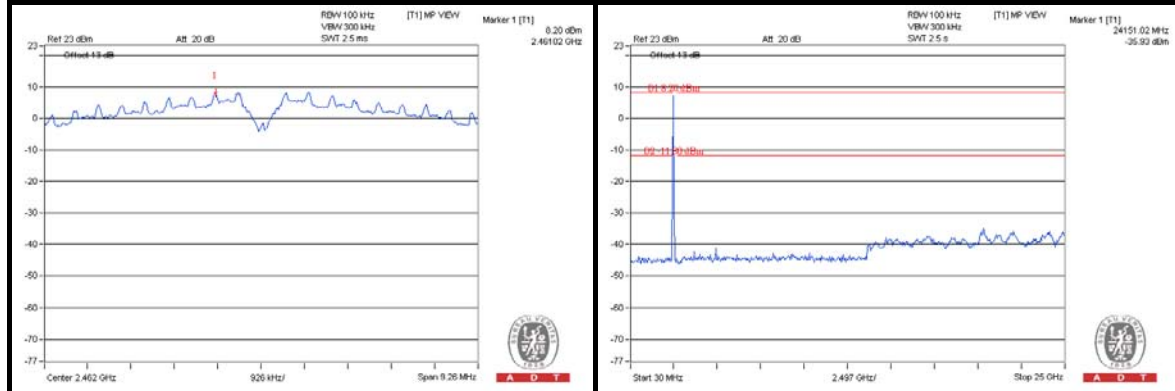

802.11g

CH 1

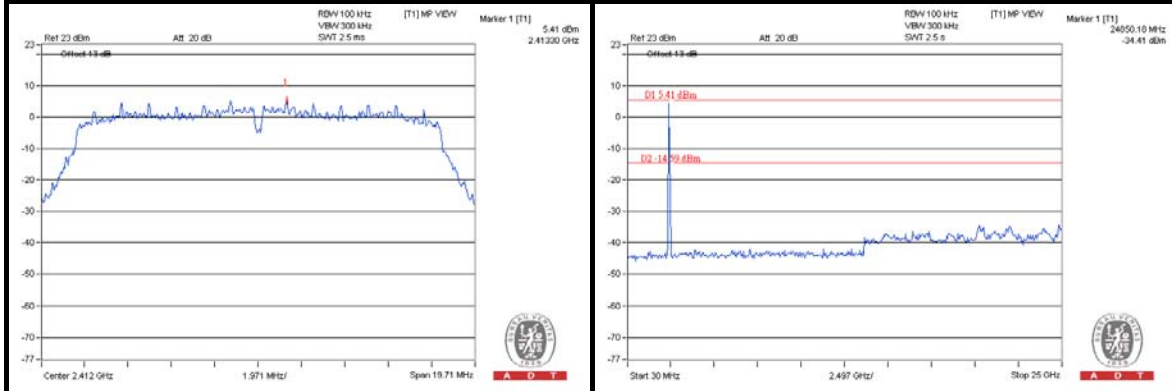

CH 6

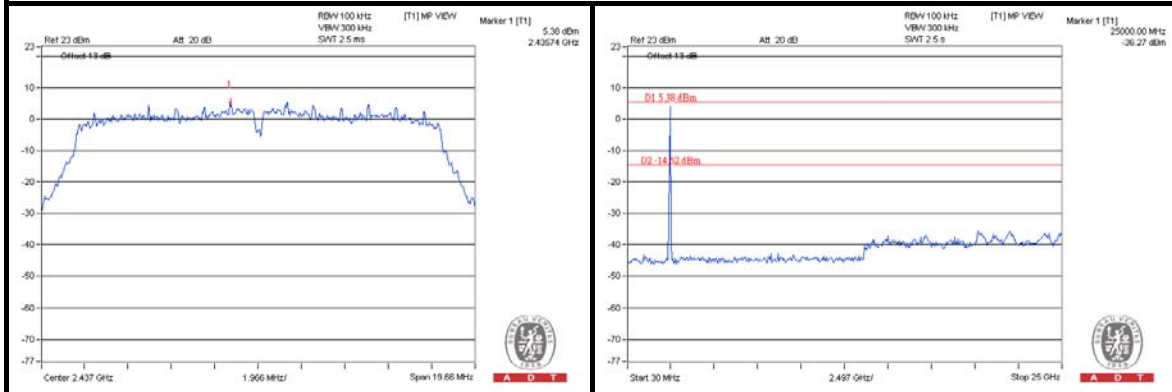

CH 11

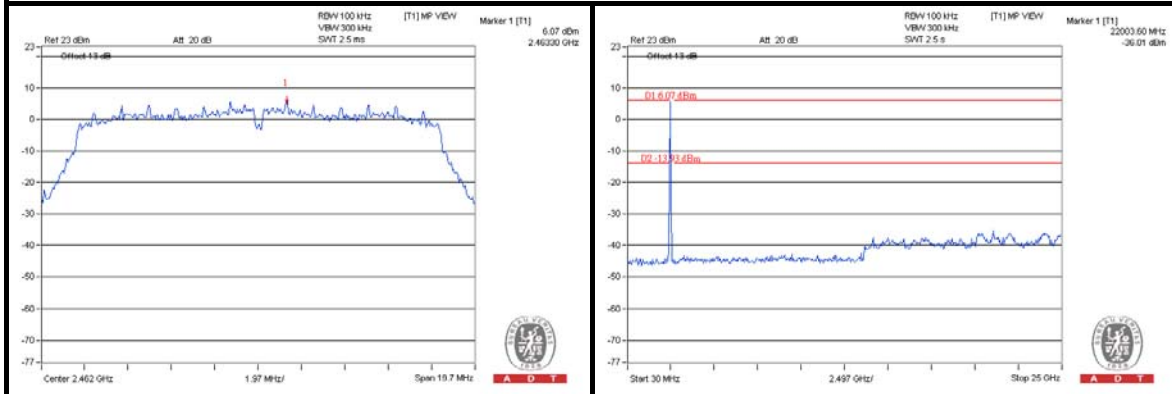

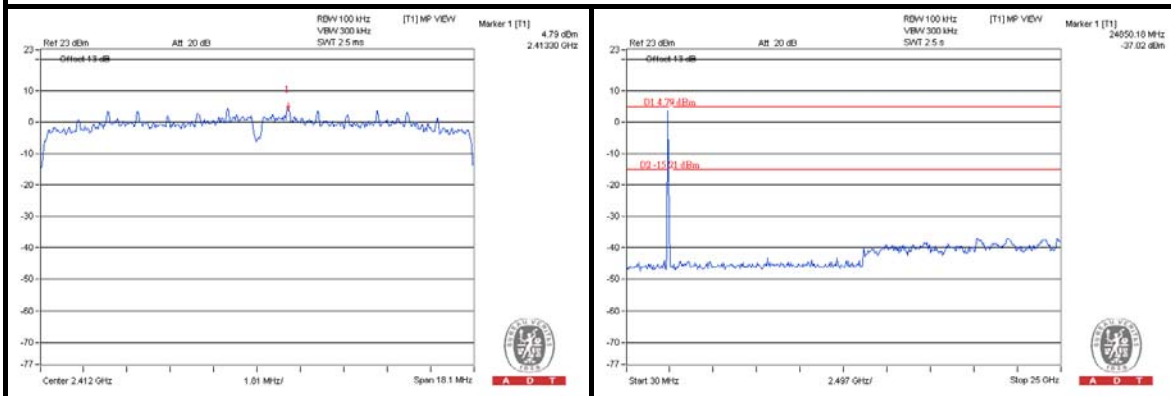
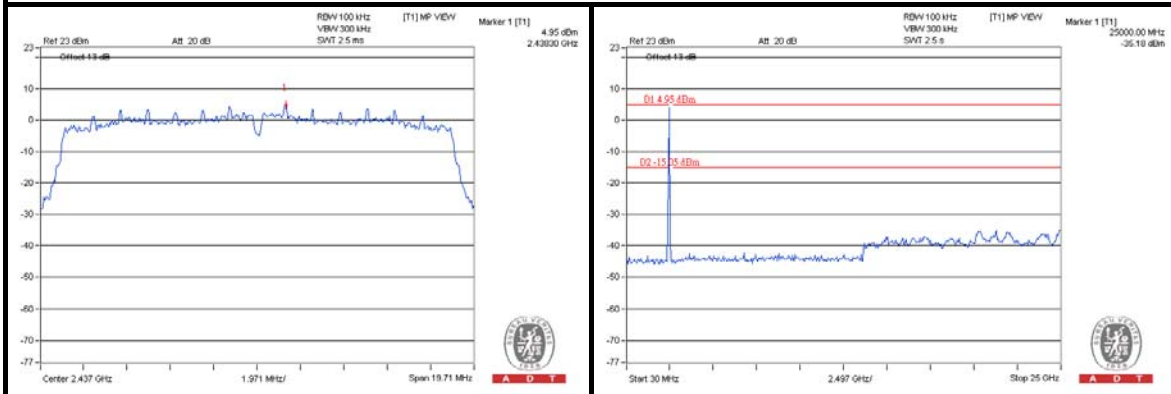
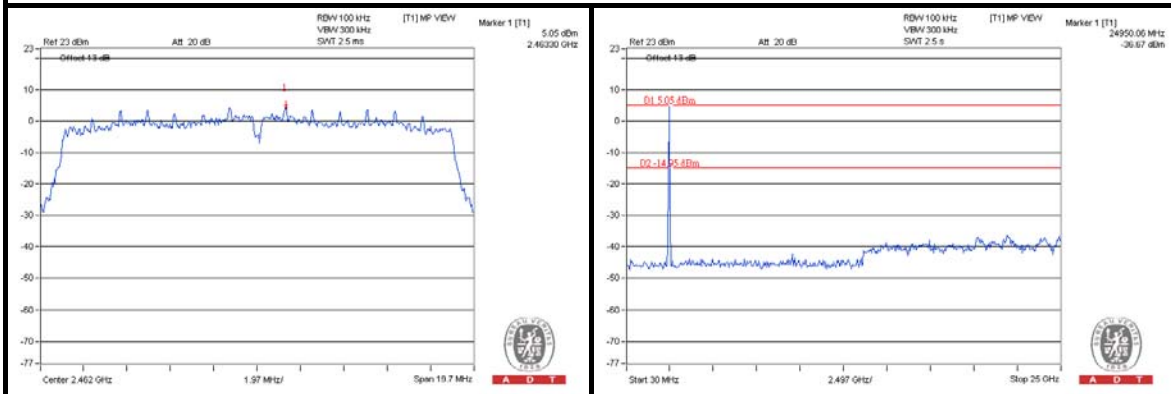
802.11n (20MHz)**CH 1****CH 6****CH 11**

5. TEST TYPES AND RESULTS (FOR 5.0GHz BAND)

5.1 RADIATED EMISSION MEASUREMENT

5.1.1 LIMITS OF RADIATED EMISSION MEASUREMENT

Radiated emissions which fall in the restricted bands must comply with the radiated emission limits specified as below table. Other emissions shall be at least 20dB below the highest level of the desired power:

FREQUENCIES (MHz)	FIELD STRENGTH (microvolts/meter)	MEASUREMENT DISTANCE (meters)
0.009 ~ 0.490	2400/F(kHz)	300
0.490 ~ 1.705	24000/F(kHz)	30
1.705 ~ 30.0	30	30
30 ~ 88	100	3
88 ~ 216	150	3
216 ~ 960	200	3
Above 960	500	3

NOTE:

1. The lower limit shall apply at the transition frequencies.
2. Emission level (dBuV/m) = 20 log Emission level (uV/m).
3. For frequencies above 1000MHz, the field strength limits are based on average detector, however, the peak field strength of any emission shall not exceed the maximum permitted average limits, specified above by more than 20dB under any condition of modulation.



A D T

5.1.2 TEST INSTRUMENTS

Same as item 4.1.2.

5.1.3 TEST PROCEDURES

Same as item 4.1.3.

5.1.4 DEVIATION FROM TEST STANDARD

No deviation.

5.1.5 TEST SETUP

Same as item 4.1.5.

5.1.6 EUT OPERATING CONDITIONS

Same as item 4.1.6.



A D T

5.1.7 TEST RESULTS

ABOVE 1GHz DATA

802.11a

CHANNEL	TX Channel 149	DETECTOR FUNCTION	Peak (PK)
FREQUENCY RANGE	1GHz ~ 40GHz		Average (AV)

ANTENNA POLARITY & TEST DISTANCE: HORIZONTAL AT 3 M								
NO.	FREQ. (MHz)	EMISSION LEVEL (dBuV/m)	LIMIT (dBuV/m)	MARGIN (dB)	ANTENNA HEIGHT (m)	TABLE ANGLE (Degree)	RAW VALUE (dBuV)	CORRECTION FACTOR (dB/m)
1	5725.00	70.0 PK	74.0	-4.0	1.09 H	196	64.60	5.39
2	5725.00	50.9 AV	54.0	-3.2	1.09 H	196	45.46	5.39
3	*5745.00	104.9 PK			1.09 H	196	99.50	5.41
4	*5745.00	92.9 AV			1.09 H	196	87.53	5.41
5	11490.00	54.1 PK	74.0	-20.0	1.01 H	239	37.62	16.43
6	11490.00	40.7 AV	54.0	-13.4	1.01 H	239	24.22	16.43
ANTENNA POLARITY & TEST DISTANCE: VERTICAL AT 3 M								
NO.	FREQ. (MHz)	EMISSION LEVEL (dBuV/m)	LIMIT (dBuV/m)	MARGIN (dB)	ANTENNA HEIGHT (m)	TABLE ANGLE (Degree)	RAW VALUE (dBuV)	CORRECTION FACTOR (dB/m)
1	5725.00	72.0 PK	74.0	-2.0	1.13 V	159	66.57	5.39
2	5725.00	50.5 AV	54.0	-3.6	1.13 V	159	45.06	5.39
3	*5745.00	106.6 PK			1.13 V	159	101.22	5.41
4	*5745.00	93.6 AV			1.13 V	159	88.16	5.41
5	11490.00	54.5 PK	74.0	-19.5	1.05 V	96	38.11	16.43
6	11490.00	40.8 AV	54.0	-13.2	1.05 V	96	24.36	16.43

REMARKS:

1. Emission Level(dBuV/m) = Raw Value(dBuV) + Correction Factor(dB/m)
2. Correction Factor(dB/m) = Antenna Factor(dB/m) + Cable Factor(dB) – Pre-Amplifier Factor(dB)
3. The other emission levels were very low against the limit.
4. Margin value = Emission Level – Limit value
5. " * ": Fundamental frequency.



A D T

CHANNEL	TX Channel 157	DETECTOR FUNCTION	Peak (PK)
FREQUENCY RANGE	1GHz ~ 40GHz		Average (AV)

ANTENNA POLARITY & TEST DISTANCE: HORIZONTAL AT 3 M								
NO.	FREQ. (MHz)	EMISSION LEVEL (dBuV/m)	LIMIT (dBuV/m)	MARGIN (dB)	ANTENNA HEIGHT (m)	TABLE ANGLE (Degree)	RAW VALUE (dBuV)	CORRECTION FACTOR (dB/m)
1	*5785.00	104.9 PK			1.10 H	191	99.47	5.47
2	*5785.00	93.2 AV			1.10 H	191	87.74	5.47
3	11570.00	54.6 PK	74.0	-19.4	1.02 H	248	38.19	16.45
4	11570.00	40.8 AV	54.0	-13.2	1.02 H	248	24.31	16.45
ANTENNA POLARITY & TEST DISTANCE: VERTICAL AT 3 M								
NO.	FREQ. (MHz)	EMISSION LEVEL (dBuV/m)	LIMIT (dBuV/m)	MARGIN (dB)	ANTENNA HEIGHT (m)	TABLE ANGLE (Degree)	RAW VALUE (dBuV)	CORRECTION FACTOR (dB/m)
1	*5785.00	105.6 PK			1.12 V	157	100.11	5.47
2	*5785.00	92.9 AV			1.12 V	157	87.47	5.47
3	11570.00	54.5 PK	74.0	-19.5	1.02 V	98	38.06	16.45
4	11570.00	40.6 AV	54.0	-13.4	1.02 V	98	24.15	16.45

REMARKS:

1. Emission Level(dBuV/m) = Raw Value(dBuV) + Correction Factor(dB/m)
2. Correction Factor(dB/m) = Antenna Factor(dB/m) + Cable Factor(dB) – Pre-Amplifier Factor(dB)
3. The other emission levels were very low against the limit.
4. Margin value = Emission Level – Limit value
5. " * ": Fundamental frequency.



A D T

CHANNEL	TX Channel 165	DETECTOR FUNCTION	Peak (PK)
FREQUENCY RANGE	1GHz ~ 40GHz		Average (AV)

ANTENNA POLARITY & TEST DISTANCE: HORIZONTAL AT 3 M

NO.	FREQ. (MHz)	EMISSION LEVEL (dBuV/m)	LIMIT (dBuV/m)	MARGIN (dB)	ANTENNA HEIGHT (m)	TABLE ANGLE (Degree)	RAW VALUE (dBuV)	CORRECTION FACTOR (dB/m)
1	*5825.00	103.6 PK			1.12 H	193	98.06	5.57
2	*5825.00	91.6 AV			1.12 H	193	86.05	5.57
3	5850.00	59.1 PK	74.0	-14.9	1.12 H	193	53.46	5.63
4	5850.00	47.5 AV	54.0	-6.5	1.12 H	193	41.85	5.63
5	11650.00	54.3 PK	74.0	-19.7	1.01 H	239	38.14	16.12
6	11650.00	40.3 AV	54.0	-13.7	1.01 H	239	24.18	16.12

ANTENNA POLARITY & TEST DISTANCE: VERTICAL AT 3 M

NO.	FREQ. (MHz)	EMISSION LEVEL (dBuV/m)	LIMIT (dBuV/m)	MARGIN (dB)	ANTENNA HEIGHT (m)	TABLE ANGLE (Degree)	RAW VALUE (dBuV)	CORRECTION FACTOR (dB/m)
1	*5825.00	107.1 PK			1.07 V	143	101.48	5.57
2	*5825.00	93.3 AV			1.07 V	143	87.75	5.57
3	5850.00	62.2 PK	74.0	-11.9	1.07 V	143	56.52	5.63
4	5850.00	48.6 AV	54.0	-5.5	1.07 V	143	42.92	5.63
5	11650.00	54.3 PK	74.0	-19.7	1.02 V	100	38.21	16.12
6	11650.00	40.5 AV	54.0	-13.6	1.02 V	100	24.33	16.12

REMARKS:

1. Emission Level(dBuV/m) = Raw Value(dBuV) + Correction Factor(dB/m)
2. Correction Factor(dB/m) = Antenna Factor(dB/m) + Cable Factor(dB) – Pre-Amplifier Factor(dB)
3. The other emission levels were very low against the limit.
4. Margin value = Emission Level – Limit value
5. " * ": Fundamental frequency.



A D T

802.11n (20MHz)

CHANNEL	TX Channel 149	DETECTOR FUNCTION	Peak (PK)
FREQUENCY RANGE	1GHz ~ 40GHz		Average (AV)

ANTENNA POLARITY & TEST DISTANCE: HORIZONTAL AT 3 M								
NO.	FREQ. (MHz)	EMISSION LEVEL (dBuV/m)	LIMIT (dBuV/m)	MARGIN (dB)	ANTENNA HEIGHT (m)	TABLE ANGLE (Degree)	RAW VALUE (dBuV)	CORRECTION FACTOR (dB/m)
1	5725.00	68.9 PK	74.0	-5.1	1.10 H	191	63.52	5.39
2	5725.00	50.4 AV	54.0	-3.6	1.10 H	191	45.05	5.39
3	*5745.00	103.2 PK			1.10 H	191	97.77	5.41
4	*5745.00	91.9 AV			1.10 H	191	86.48	5.41
5	11490.00	54.8 PK	74.0	-19.2	1.03 H	248	38.35	16.43
6	11490.00	41.1 AV	54.0	-12.9	1.03 H	248	24.63	16.43
ANTENNA POLARITY & TEST DISTANCE: VERTICAL AT 3 M								
NO.	FREQ. (MHz)	EMISSION LEVEL (dBuV/m)	LIMIT (dBuV/m)	MARGIN (dB)	ANTENNA HEIGHT (m)	TABLE ANGLE (Degree)	RAW VALUE (dBuV)	CORRECTION FACTOR (dB/m)
1	5725.00	71.7 PK	74.0	-2.3	1.08 V	151	66.34	5.39
2	5725.00	50.3 AV	54.0	-3.8	1.08 V	151	44.86	5.39
3	*5745.00	104.6 PK			1.08 V	151	99.19	5.41
4	*5745.00	93.3 AV			1.08 V	151	87.88	5.41
5	11490.00	54.7 PK	74.0	-19.3	1.02 V	103	38.26	16.43
6	11490.00	40.9 AV	54.0	-13.1	1.02 V	103	24.43	16.43

REMARKS:

1. Emission Level(dBuV/m) = Raw Value(dBuV) + Correction Factor(dB/m)
2. Correction Factor(dB/m) = Antenna Factor(dB/m) + Cable Factor(dB) – Pre-Amplifier Factor(dB)
3. The other emission levels were very low against the limit.
4. Margin value = Emission Level – Limit value
5. " * ": Fundamental frequency.



A D T

CHANNEL	TX Channel 157	DETECTOR FUNCTION	Peak (PK)
FREQUENCY RANGE	1GHz ~ 40GHz		Average (AV)

ANTENNA POLARITY & TEST DISTANCE: HORIZONTAL AT 3 M								
NO.	FREQ. (MHz)	EMISSION LEVEL (dBuV/m)	LIMIT (dBuV/m)	MARGIN (dB)	ANTENNA HEIGHT (m)	TABLE ANGLE (Degree)	RAW VALUE (dBuV)	CORRECTION FACTOR (dB/m)
1	*5785.00	103.0 PK			1.10 H	186	97.49	5.47
2	*5785.00	91.4 AV			1.10 H	186	85.90	5.47
3	11570.00	54.9 PK	74.0	-19.1	1.02 H	253	38.41	16.45
4	11570.00	41.2 AV	54.0	-12.8	1.02 H	253	24.77	16.45
ANTENNA POLARITY & TEST DISTANCE: VERTICAL AT 3 M								
NO.	FREQ. (MHz)	EMISSION LEVEL (dBuV/m)	LIMIT (dBuV/m)	MARGIN (dB)	ANTENNA HEIGHT (m)	TABLE ANGLE (Degree)	RAW VALUE (dBuV)	CORRECTION FACTOR (dB/m)
1	*5785.00	103.6 PK			1.13 V	148	98.15	5.47
2	*5785.00	91.7 AV			1.13 V	148	86.25	5.47
3	11570.00	54.8 PK	74.0	-19.2	1.01 V	105	38.33	16.45
4	11570.00	40.9 AV	54.0	-13.1	1.01 V	105	24.49	16.45

REMARKS:

1. Emission Level(dBuV/m) = Raw Value(dBuV) + Correction Factor(dB/m)
2. Correction Factor(dB/m) = Antenna Factor(dB/m) + Cable Factor(dB) – Pre-Amplifier Factor(dB)
3. The other emission levels were very low against the limit.
4. Margin value = Emission Level – Limit value
5. " * ": Fundamental frequency.



A D T

CHANNEL	TX Channel 165	DETECTOR FUNCTION	Peak (PK)
FREQUENCY RANGE	1GHz ~ 40GHz		Average (AV)

ANTENNA POLARITY & TEST DISTANCE: HORIZONTAL AT 3 M								
NO.	FREQ. (MHz)	EMISSION LEVEL (dBuV/m)	LIMIT (dBuV/m)	MARGIN (dB)	ANTENNA HEIGHT (m)	TABLE ANGLE (Degree)	RAW VALUE (dBuV)	CORRECTION FACTOR (dB/m)
1	*5825.00	102.5 PK			1.11 H	190	96.94	5.57
2	*5825.00	90.3 AV			1.11 H	190	84.69	5.57
3	5850.00	58.5 PK	74.0	-15.5	1.11 H	190	52.88	5.63
4	5850.00	46.5 AV	54.0	-7.5	1.11 H	190	40.91	5.63
5	11650.00	54.5 PK	74.0	-19.5	1.03 H	244	38.42	16.12
6	11650.00	40.8 AV	54.0	-13.2	1.03 H	244	24.65	16.12
ANTENNA POLARITY & TEST DISTANCE: VERTICAL AT 3 M								
NO.	FREQ. (MHz)	EMISSION LEVEL (dBuV/m)	LIMIT (dBuV/m)	MARGIN (dB)	ANTENNA HEIGHT (m)	TABLE ANGLE (Degree)	RAW VALUE (dBuV)	CORRECTION FACTOR (dB/m)
1	*5825.00	103.5 PK			1.12 V	157	97.96	5.57
2	*5825.00	91.9 AV			1.12 V	157	86.34	5.57
3	5850.00	60.3 PK	74.0	-13.7	1.12 V	157	54.70	5.63
4	5850.00	47.9 AV	54.0	-6.1	1.12 V	157	42.26	5.63
5	11650.00	54.4 PK	74.0	-19.6	1.00 V	99	38.24	16.12
6	11650.00	40.6 AV	54.0	-13.4	1.00 V	99	24.45	16.12

REMARKS:

1. Emission Level(dBuV/m) = Raw Value(dBuV) + Correction Factor(dB/m)
2. Correction Factor(dB/m) = Antenna Factor(dB/m) + Cable Factor(dB) – Pre-Amplifier Factor(dB)
3. The other emission levels were very low against the limit.
4. Margin value = Emission Level – Limit value
5. " * ": Fundamental frequency.



A D T

BELOW 1GHz WORST-CASE DATA

802.11a

CHANNEL	TX Channel 157	DETECTOR FUNCTION	Quasi-Peak (QP)
FREQUENCY RANGE	30MHz ~ 1GHz		

ANTENNA POLARITY & TEST DISTANCE: HORIZONTAL AT 3 M

NO.	FREQ. (MHz)	EMISSION LEVEL (dBuV/m)	LIMIT (dBuV/m)	MARGIN (dB)	ANTENNA HEIGHT (m)	TABLE ANGLE (Degree)	RAW VALUE (dBuV)	CORRECTION FACTOR (dB/m)
1	57.16	31.6 QP	40.0	-8.4	1.08 H	178	45.81	-14.18
2	115.36	34.0 QP	43.5	-9.5	1.00 H	206	50.11	-16.13
3	167.74	35.2 QP	43.5	-8.3	1.42 H	87	48.63	-13.42
4	270.56	35.1 QP	46.0	-10.9	1.14 H	71	47.49	-12.38
5	335.55	36.4 QP	46.0	-9.6	1.00 H	106	47.10	-10.67
6	801.15	36.1 QP	46.0	-9.9	1.07 H	96	38.01	-1.94

ANTENNA POLARITY & TEST DISTANCE: VERTICAL AT 3 M

NO.	FREQ. (MHz)	EMISSION LEVEL (dBuV/m)	LIMIT (dBuV/m)	MARGIN (dB)	ANTENNA HEIGHT (m)	TABLE ANGLE (Degree)	RAW VALUE (dBuV)	CORRECTION FACTOR (dB/m)
1	57.16	32.3 QP	40.0	-7.7	1.32 V	172	46.44	-14.18
2	115.36	35.7 QP	43.5	-7.8	1.05 V	202	51.86	-16.13
3	167.74	35.0 QP	43.5	-8.5	1.04 V	94	48.45	-13.42
4	270.56	37.0 QP	46.0	-9.0	1.03 V	68	49.39	-12.38
5	408.30	36.8 QP	46.0	-9.2	1.00 V	9	46.29	-9.47
6	798.24	38.9 QP	46.0	-7.2	1.52 V	102	40.83	-1.98

REMARKS:

1. Emission Level(dBuV/m) = Raw Value(dBuV) + Correction Factor(dB/m)
2. Correction Factor(dB/m) = Antenna Factor(dB/m) + Cable Factor(dB) – Pre-Amplifier Factor(dB)
3. The other emission levels were very low against the limit.
4. Margin value = Emission Level – Limit value



5.2 CONDUCTED EMISSION MEASUREMENT

5.2.1 LIMITS OF CONDUCTED EMISSION MEASUREMENT

FREQUENCY OF EMISSION (MHz)	CONDUCTED LIMIT (dBµV)	
	Quasi-peak	Average
0.15 ~ 0.5	66 to 56	56 to 46
0.5 ~ 5	56	46
5 ~ 30	60	50

NOTE: 1. The lower limit shall apply at the transition frequencies.
2. The limit decreases in line with the logarithm of the frequency in the range of 0.15 to 0.50MHz.

5.2.2 TEST INSTRUMENTS

Same as item 4.2.2.

5.2.3 TEST PROCEDURES

Same as item 4.2.3.

5.2.4 DEVIATION FROM TEST STANDARD

No deviation.

5.2.5 TEST SETUP

Same as item 4.2.5.

5.2.6 EUT OPERATING CONDITIONS

Same as item 4.1.6.

5.2.7 TEST RESULTS

CONDUCTED WORST-CASE DATA : 802.11a

PHASE	Line 1	6dB BANDWIDTH	9kHz
--------------	--------	----------------------	------

No	Freq. [MHz]	Corr. Factor (dB)	Reading Value		Emission Level		Limit		Margin	
			[dB (uV)]		[dB (uV)]		[dB (uV)]		(dB)	
			Q.P.	AV.	Q.P.	AV.	Q.P.	AV.	Q.P.	AV.
1	0.16946	0.14	37.72	35.28	37.86	35.42	64.99	54.99	-27.13	-19.57
2	0.19562	0.14	46.15	46.12	46.29	46.26	63.79	53.79	-17.51	-7.54
3	0.29442	0.15	31.44	30.33	31.59	30.48	60.40	50.40	-28.80	-19.91
4	13.82422	0.83	35.78	35.36	36.61	36.19	60.00	50.00	-23.39	-13.81
5	16.89481	1.00	42.85	41.51	43.85	42.51	60.00	50.00	-16.15	-7.49
6	19.96807	1.18	36.76	36.65	37.94	37.83	60.00	50.00	-22.06	-12.17

REMARKS:

1. Q.P. and AV. are abbreviations of quasi-peak and average individually.
2. The emission levels of other frequencies were very low against the limit.
3. Margin value = Emission Level – Limit value
4. Correction Factor = Insertion loss + Cable loss
5. Emission Level = Correction Factor + Reading Value

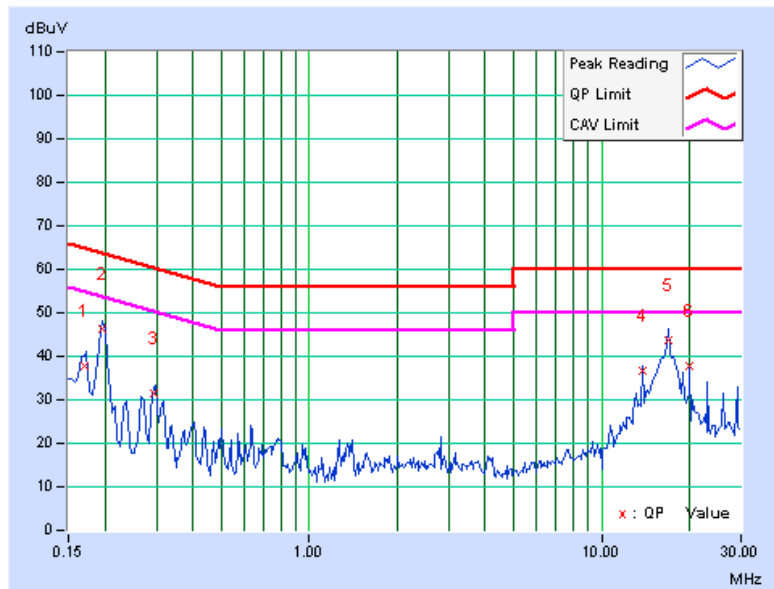

PHASE	Line 2	6dB BANDWIDTH	9kHz
--------------	--------	----------------------	------

No	Freq. [MHz]	Corr. Factor (dB)	Reading Value		Emission Level		Limit		Margin	
			[dB (uV)]		[dB (uV)]		[dB (uV)]		(dB)	
			Q.P.	AV.	Q.P.	AV.	Q.P.	AV.	Q.P.	AV.
1	0.16825	0.11	44.34	40.14	44.45	40.25	65.05	55.05	-20.60	-14.80
2	0.19687	0.11	43.67	43.18	43.78	43.29	63.74	53.74	-19.96	-10.45
3	0.30234	0.13	32.51	27.49	32.64	27.62	60.18	50.18	-27.54	-22.56
4	13.82422	0.60	35.82	35.21	36.42	35.81	60.00	50.00	-23.58	-14.19
5	16.89590	0.70	42.93	41.58	43.63	42.28	60.00	50.00	-16.37	-7.72
6	23.03906	0.85	31.36	29.12	32.21	29.97	60.00	50.00	-27.79	-20.03

REMARKS:

1. Q.P. and AV. are abbreviations of quasi-peak and average individually.
2. The emission levels of other frequencies were very low against the limit.
3. Margin value = Emission Level – Limit value
4. Correction Factor = Insertion loss + Cable loss
5. Emission Level = Correction Factor + Reading Value

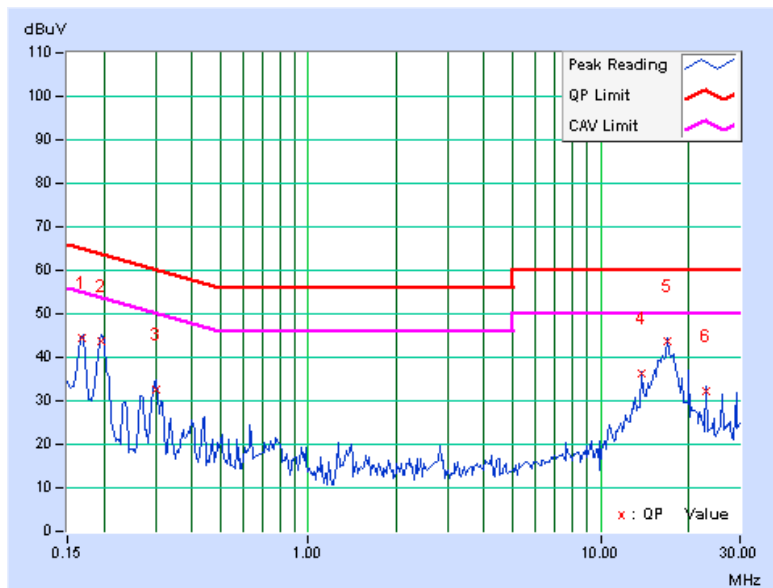



A D T

5.3 6dB BANDWIDTH MEASUREMENT

5.3.1 LIMITS OF 6dB BANDWIDTH MEASUREMENT

The minimum of 6dB Bandwidth Measurement is 0.5MHz.

5.3.2 TEST SETUP

Same as item 4.3.2.

5.3.3 TEST INSTRUMENTS

Refer to section 4.1.2 to get information of above instrument.

5.3.4 TEST PROCEDURE

Same as item 4.3.4.

5.3.5 DEVIATION FROM TEST STANDARD

No deviation.

5.3.6 EUT OPERATING CONDITIONS

Same as item 4.3.6.



A D T

5.3.7 TEST RESULTS

CHANNEL	FREQUENCY (MHz)	6dB BANDWIDTH (MHz)	MINIMUM LIMIT (MHz)	PASS / FAIL
802.11a				
149	5745	15.82	0.5	PASS
157	5785	15.53	0.5	PASS
165	5825	15.81	0.5	PASS
802.11n (20MHz)				
149	5745	17.09	0.5	PASS
157	5785	16.87	0.5	PASS
165	5825	16.16	0.5	PASS



A D T

5.4 CONDUCTED OUTPUT POWER

5.4.1 LIMITS OF CONDUCTED OUTPUT POWER MEASUREMENT

For systems using digital modulation in the 5725 –5850 MHz bands: 1 Watt (30dBm)

5.4.2 TEST SETUP

Same as Item 4.4.2.

5.4.3 INSTRUMENTS

Refer to section 4.1.2 to get information of above instrument.

5.4.4 TEST PROCEDURES

Same as Item 4.4.4.

5.4.5 DEVIATION FROM TEST STANDARD

No deviation.

5.4.6 EUT OPERATING CONDITIONS

Same as Item 4.3.6.



5.4.7 TEST RESULTS

FOR PEAK POWER

CHANNEL	FREQUENCY (MHz)	PEAK POWER (dBm)	PEAK POWER (mW)	LIMIT (dBm)	PASS/FAIL
802.11a					
149	5745	19.28	84.7	30	PASS
157	5785	19.96	99.1	30	PASS
165	5825	19.96	99.1	30	PASS
802.11n (20MHz)					
149	5745	19.39	86.9	30	PASS
157	5785	19.68	92.9	30	PASS
165	5825	19.44	87.9	30	PASS

FOR AVERAGE POWER

CHANNEL	FREQUENCY (MHz)	AVERAGE POWER (dBm)
802.11a		
149	5745	13.06
157	5785	13.26
165	5825	13.63
802.11n (20MHz)		
149	5745	12.42
157	5785	12.69
165	5825	12.67



A D T

5.5 POWER SPECTRAL DENSITY MEASUREMENT

5.5.1 LIMITS OF POWER SPECTRAL DENSITY MEASUREMENT

The Maximum of Power Spectral Density Measurement is 8dBm.

5.5.2 TEST SETUP

Same as item 4.5.2.

5.5.3 TEST INSTRUMENTS

Refer to section 4.1.2 to get information of above instrument.

5.5.4 TEST PROCEDURE.

Same as item 4.5.4.

5.5.5 DEVIATION FROM TEST STANDARD

No deviation.

5.5.6 EUT OPERATING CONDITION

Same as item 4.3.6.



5.5.7 TEST RESULTS

CHANNEL	FREQUENCY (MHz)	PSD W/O DUTY FACTOR (dBm)	DUTY FACTOR	PSD WITH DUTY FACTOR (dBm)	MAXIMUM LIMIT (dBm)	PASS/FAIL
802.11a						
149	5745	-11.60	0.28	-11.32	8	PASS
157	5785	-10.17	0.28	-9.89	8	PASS
165	5825	-10.72	0.28	-10.44	8	PASS
802.11n (20MHz)						
149	5745	-12.40	0.23	-12.17	8	PASS
157	5785	-12.08	0.23	-11.85	8	PASS
165	5825	-11.60	0.23	-11.37	8	PASS

Note: Refer to section 3.3 for duty cycle spectrum plot.



A D T

5.6 CONDUCTED OUT OF BAND EMISSION MEASUREMENT

5.6.1 LIMITS OF CONDUCTED OUT OF BAND EMISSION MEASUREMENT

Below -20dB of the highest emission level of operating band (in 100kHz Resolution Bandwidth).

5.6.2 TEST SETUP

Same as Item 4.6.2

5.6.3 TEST INSTRUMENTS

Refer to section 4.1.2 to get information of above instrument.

5.6.4 TEST PROCEDURE

Same as Item 4.6.4

5.6.5 DEVIATION FROM TEST STANDARD

No deviation.

5.6.6 EUT OPERATING CONDITION

Same as Item 4.3.6

5.6.7 TEST RESULTS

The spectrum plots are attached on the following pages. D1 line indicates the highest level, and D2 line indicates the 20dB offset below D1. It shows compliance with the requirement.

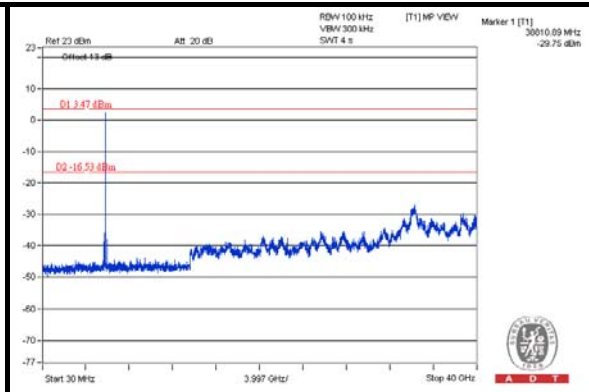
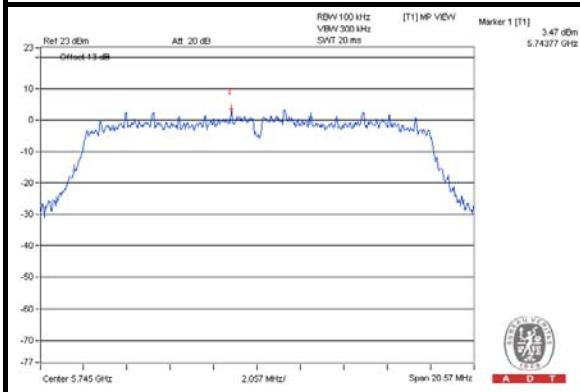
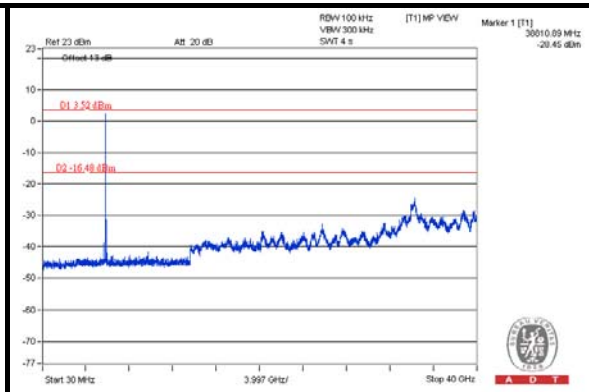
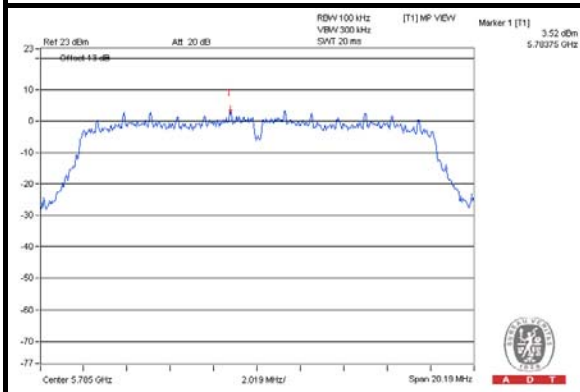
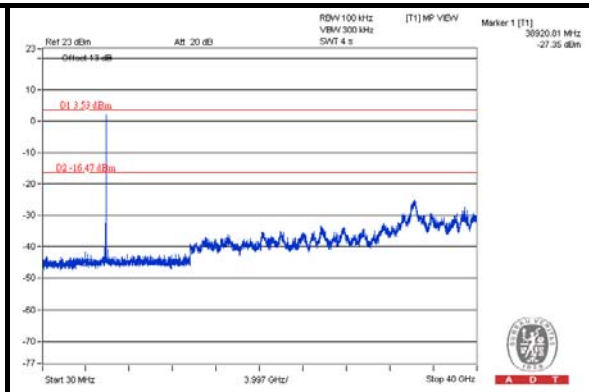
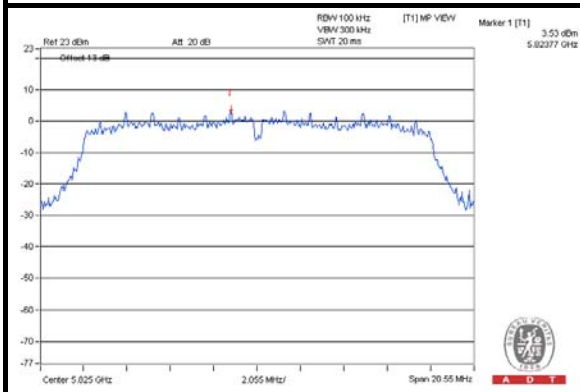
802.11a**CH 149****CH 157****CH 165**

802.11n (20MHz)

CH 149

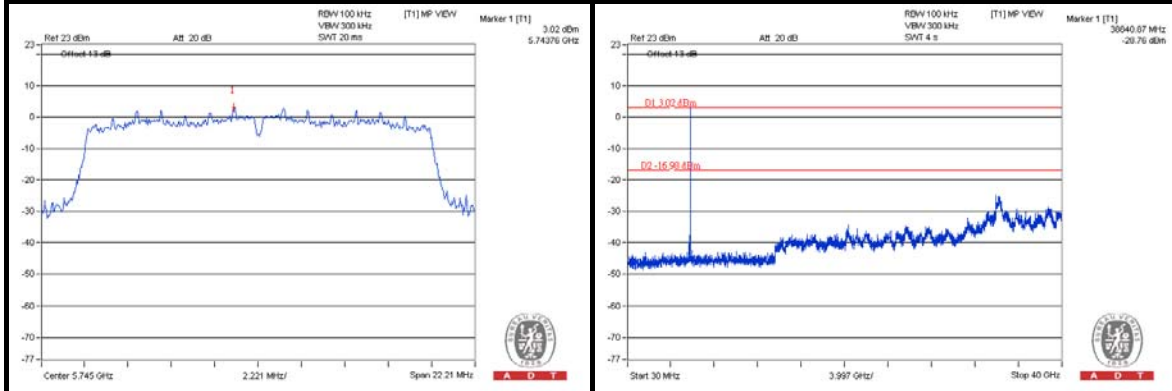

CH 157

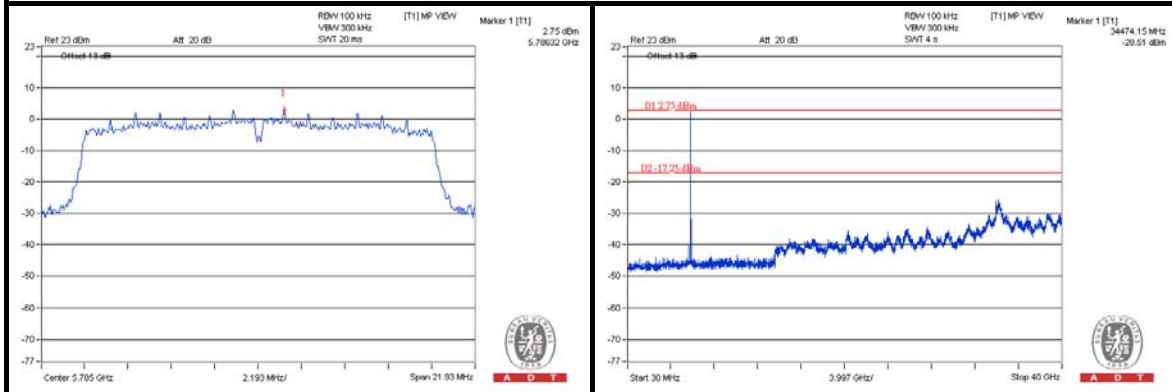

CH 165

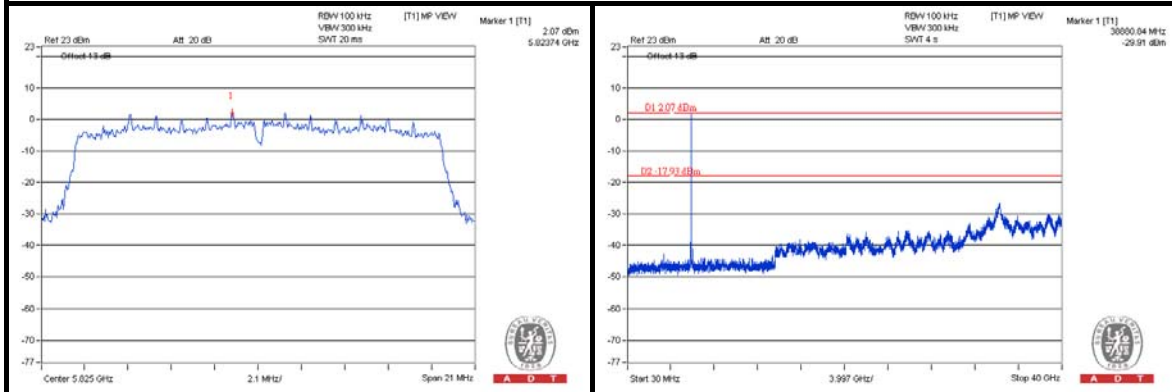



A D T

6. PHOTOGRAPHS OF THE TEST CONFIGURATION

Please refer to the attached file (Test Setup Photo).



A D T

7. INFORMATION ON THE TESTING LABORATORIES

We, Bureau Veritas Consumer Products Services (H.K.) Ltd., Taoyuan Branch, were founded in 1988 to provide our best service in EMC, Radio, Telecom and Safety consultation. Our laboratories are accredited and approved according to ISO/IEC 17025.

If you have any comments, please feel free to contact us at the following:

Linko EMC/RF Lab

Tel: 886-2-26052180

Fax: 886-2-26051924

Hsin Chu EMC/RF Lab

Tel: 886-3-5935343

Fax: 886-3-5935342

Hwa Ya EMC/RF/Safety/Telecom Lab

Tel: 886-3-3183232

Fax: 886-3-3270892

Email: service.adt@tw.bureauveritas.com

Web Site: www.bureauveritas-adt.com

The address and road map of all our labs can be found in our web site also.



A D T

8. APPENDIX A – MODIFICATIONS RECORDERS FOR ENGINEERING CHANGES TO THE EUT BY THE LAB

No modifications were made to the EUT by the lab during the test.

---END---